



(11) **EP 2 911 496 B1**

(12) **EUROPEAN PATENT SPECIFICATION**

(45) Date of publication and mention of the grant of the patent:
28.08.2019 Bulletin 2019/35

(51) Int Cl.:
A01C 7/04 (2006.01) A01C 19/02 (2006.01)

(21) Application number: **13784090.6**

(86) International application number:
PCT/US2013/065630

(22) Date of filing: **18.10.2013**

(87) International publication number:
WO 2014/066157 (01.05.2014 Gazette 2014/18)

(54) **AIR SEED METER DISC WITH FLOW DIRECTING POCKETS**

PNEUMATISCHE SAATGUTVEREINZELUNGSSCHEIBE MIT STRÖMUNGSLEITENDEN TASCHEN

DISQUE DOSEUR DE GRAINES PNEUMATIQUE AVEC DES POCHE DIRIGEANT L'ÉCOULEMENT

(84) Designated Contracting States:
AL AT BE BG CH CY CZ DE DK EE ES FI FR GB GR HR HU IE IS IT LI LT LU LV MC MK MT NL NO PL PT RO RS SE SI SK SM TR

(30) Priority: **23.10.2012 US 201261717384 P**

(43) Date of publication of application:
02.09.2015 Bulletin 2015/36

(73) Proprietor: **Kinze Manufacturing, Inc. Williamsburg, IA 52361 (US)**

(72) Inventors:
• **WILHELMI, Matthew J. Williamsburg, Iowa 52361 (US)**
• **BROCKMANN, Kale J. Williamsburg, Iowa 52361 (US)**

(74) Representative: **Tomkinson, Alexandra Bailey Walsh & Co LLP 1 York Place Leeds, LS1 2DR (GB)**

(56) References cited:
US-A- 4 047 638 US-A- 5 058 766
US-A1- 2005 204 972 US-A1- 2007 125 284

EP 2 911 496 B1

Note: Within nine months of the publication of the mention of the grant of the European patent in the European Patent Bulletin, any person may give notice to the European Patent Office of opposition to that patent, in accordance with the Implementing Regulations. Notice of opposition shall not be deemed to have been filed until the opposition fee has been paid. (Art. 99(1) European Patent Convention).

Description

FIELD OF THE INVENTION

[0001] The present invention relates generally to mechanisms used in agricultural planting machines for selecting and dispensing individual seeds. More particularly, but not exclusively, the invention relates to air seed meters used to meter seeds from a row unit on agricultural row crop planters and seeders.

BACKGROUND OF THE INVENTION

[0002] An agricultural row crop planter is a machine built for precisely distributing seed into the ground. The row crop planter generally includes a horizontal toolbar fixed to a hitch assembly for towing behind a tractor. Row units are mounted to the toolbar. In different configurations, seed may be stored at individual hoppers on each row unit, or it may be maintained in a central hopper and delivered to the row units on an as needed basis. The row units include ground-working tools for opening and closing a seed furrow, and a seed metering system for distributing seed to the seed furrow.

[0003] In its most basic form, the seed meter includes a housing and a seed disc. The housing is constructed such that it creates a reservoir to hold a seed pool. The seed disc resides within the housing and rotates about a generally horizontal central axis. As the seed disc rotates, it passes through the seed pool where it picks up individual seeds. The seeds are subsequently dispensed into a seed chute where they drop into the seed furrow.

[0004] Early seed meters were comprised of mechanical means of singulating seeds. These meters were constructed such that fingers on the face of the seed disc gripped seeds as they passed through the seed pool, subsequently releasing those seeds as they passed over the seed chute. Although these mechanical seed meters are effective, they are limited in their ability to assure singulation of seeds and are prone to dispensing duplicates (i.e., multiple seeds) and/or failing to dispense at all (i.e., skips or misses). Other mechanical meters use cells in conjunction with brushes to trap seeds within the cavity and release them over the seed chute.

[0005] Systems that are more recent include an air seed meter, e.g., vacuum or positive pressure meters, wherein the mechanical fingers have been replaced by a disc with apertures. A pressure differential is formed across opposite sides of the seed disc, which generates a suction force at the seed cell apertures. As unobstructed seed cells pass through the seed pool, seeds are drawn onto or against the seed cells and remain thereon until the seed cell passes through a region of the housing with a reduced pressure differential. To create this reduced pressure differential region, generally the "vacuum" (i.e., lower pressure) side of the seed disc is exposed to air pressure near, but not always at, atmospheric lev-

els. At this point, seeds are released from the seed cell of the seed disc and into the seed chute. Compared to mechanical meters, air seed meters promote improved singulation across a wider range of speeds. A problem that exists with an air seed meter is that it can be difficult for the suction (negative) force of the seed cell to draw seeds from a stagnant seed pool. Another problem with air seed meters, and specifically the seed disc, is that seeds not released at or near the edge of the seed disc are susceptible to increased ricochet or bounce, thereby negatively impacting seed spacing. For those air seed meters that do release seeds from at or near edge of the seed disc, seeds are sometimes knocked free of the cells on the seed disc by the seed meter housing sidewall because of the close proximity of the housing sidewall to the cell.

[0006] Therefore, there is a need in the art for an improved seed metering system that improves upon attaching seed from the seed pool to the seed disc. There is also a need in the art for a seed meter that retains the advantage of releasing seed from at or near the edge of the seed disc, but yet reduces the likelihood of unintentionally bumping the seed from the disc during rotation.

[0007] Seed spacing in the seed furrow is controlled by varying the rotational speed of the seed disc. Most commonly, seed disc rotation is driven by connection to a common driveshaft. The driveshaft runs horizontally along the length of the toolbar to connect to each row unit, and is driven by a single motor or a ground contact wheel. In this configuration, the planting rate can be adjusted for all row units uniformly by adjusting the rotational speed of the common drive shaft. This can be a tedious task, and an operator is

unlikely to adjust the gear ratio as often as necessary to maximize yields. Generally, an optimal overall rate for a given acreage will be selected prior to planting and will be maintained at that rate regardless of soil conditions. Whether using a mechanical or vacuum style seed disc, the seed disc is installed inside of the seed meter using independent fasteners and requires the use of tools to facilitate changing the disc. For example, if a farmer uses the same planter to plant corn and soybeans, he would use a different disc for the respective seed types. With planters continuing to grow in size, and more row units being added, the task of changing seed discs using independent fasteners and tools adds unnecessary burden to changing out seed discs.

[0008] There is thus a need in the art for a method and apparatus for changing the seeding rate of a seed meter to account for varying conditions, while also providing an easy to change or install method for removing and inserting a seed disc of the seed meter and rigidly retaining that seed disc within the seed meter housing.

[0009] As the art of planting progresses, emphasis on the ability of a seed metering system to accurately and consistently distribute seeds to the seed bed grows. Singulation of seeds by seed meters and spacing of seeds along the seed bed is critical in assuring that a farmer or

operator is getting the maximum crop yield out of a given acreage of land. If seeds are located too closely together, or in duplicates, they will compete with each other for available nutrients and moisture in the soil, negatively impacting growth. If seeds are located too far apart, or skipped entirely, useful nutrients and moisture will go unused by the growing crops and the farmer will not realize full yield potential of the land. The increased use of GPS and computer software to generate yield maps has provided farmers the information necessary to determine optimal real time seed spacing for each row.

[0010] Thus, there is also a need in the art for a seed meter that allows for quick and easy adjustment to adjust the spacing between seeds planted in a row.

[0011] US5058766 discloses a seed meter for a row crop planter unit having a seed disc rotating in a vertical plane. The seed disc includes improvements for seating individual seeds in seed cells on the periphery of the seed disc as the seed disc rotates through the seed reservoir. The improvements also include a barrier brush for preventing seeds from entering the delivery tube directly from the reservoir, a brush holder which limits the effective width of a peripheral retainer brush so that the retainer brush cannot retain two seeds simultaneously in the same seed cell.

SUMMARY OF THE INVENTION

[0012] It is therefore a primary object, feature, and/or advantage of the present invention to improve on or overcome the deficiencies in the art.

[0013] It is another object, feature, and/or advantage of the present invention to provide a seed metering system that allows independent control of the metering rate of each row unit of a row crop planter.

[0014] It is yet another object, feature, and/or advantage of the present invention to provide a vacuum seed disc that disrupts the seed pool as it passes through, thus loosening the seeds and directing the seeds towards the suction in the seed cell.

[0015] It is still another object, feature, and/or advantage of the present invention to reduce the likelihood that a seed drawn onto or against a seed cell can be knocked free of the seed cell as it passes by the adjacent housing wall.

[0016] It is a further object, feature, and/or advantage of the present invention to provide a seed disc having a pocket for adhering a seed to the disc and for aid in delivering the seed to the soil.

[0017] These objects and advantages are met by an air seed meter according to claim 1 and a seed disc for an air meter according to claim 12. Each respective channel is substantially inside of the seed cells and forward of its corresponding seed cell with respect to the rotational direction of the disc. Each respective channel has a length greater than its width. Each respective channel is oriented on the seed disc such that the length of the channel is at an oblique angle to a radius line of its seed

cell such that the inner forward corner of the channel leads the outer forward corner with respect to the direction of rotation.

[0018] In one embodiment there is provided a seed disc for use with an air seed meter of an agricultural implement comprising: a cylindrical structure having first and second sides and containing a plurality of apertures therethrough, said apertures being arranged in a radial array a distance from the axis of the cylindrical structure; a plurality of channels arranged in a radial array and positioned about the axis of cylindrical structure on the first side of the structure such that a respective channel is substantially radially inward and forward of a corresponding aperture; and a central cylindrical aperture therein for mounting to said seed meter, characterized in that the apertures and the channels are positioned at a raised surface of the seed disc relative to an inner or outer radially spaced surface of the disc.

[0019] In one embodiment of the invention, the air seed meter includes a seed disc housed between a seed meter housing and a vacuum housing. The seed disc comprises a substantially circular member having a first side adjacent the seed meter housing and a second side adjacent the vacuum housing, and a plurality of apertures through the disc and spaced radially a distance from the axis of the member. The first side of the circular member comprises a plurality of channels arranged in a radial array about the axis of the seed disc such that a respective channel is substantially radially inward and forward of a corresponding aperture. The channels are configured to move seed adjacent the channel and to an aperture for retention until release therefrom.

BRIEF DESCRIPTION OF THE DRAWINGS

[0020]

FIG. 1 is a perspective view of a conventional planter row unit with an air seed meter attached thereto.

FIG. 2 is a side elevation view of the conventional row unit of FIG. 1.

FIG. 3 is a perspective view of an embodiment of an air seed meter.

FIG. 4 is a perspective view of an embodiment of an air seed meter, showing the opposite side of FIG. 3.

FIG. 5 is a planar view of an embodiment of the interior of the housing of the seed meter according to the invention.

FIG. 6 is a front planar view of an embodiment of the vacuum housing of the seed meter according to the invention.

FIG. 7 is a rear elevation view of an embodiment of

the interior of the vacuum housing of FIG. 6.

FIG. 8 is a side elevation view of an embodiment of the vacuum side of the seed disc.

FIG. 9 is sectional view of an embodiment of the seed disc of FIG. 8.

FIG. 10 is a perspective view of an embodiment central hub for use with an air seed meter.

FIG. 11 is another perspective view of an embodiment the central hub of FIG. 10, shown in operative relation to a seed disc.

FIG. 12 is a perspective view of an embodiment of the reservoir side of the seed disc.

FIG. 13 is an enlarged view of a portion of the seed disc of FIG. 12, showing the seed cells and seed channels.

FIG. 14 is a perspective view of an embodiment of the seed disc of FIG. 12 including a singulation mechanism in operative relationship.

FIG. 15 is a perspective view of an embodiment of the singulation mechanism of FIG. 11.

FIG. 15a is a perspective view of another embodiment of a singulation mechanism.

FIG. 16 is a perspective view of an embodiment showing the face of the singulation mechanism's rotational adjustment.

FIG. 17 is a view of an embodiment showing the singulation mechanism with the rotational adjustment removed.

FIG. 18 is a front partial sectional view of an embodiment of the seed disc and a unique drive in operative relations with the housing and other seed meter components hidden for clarity.

FIG. 19 is a cross-sectional perspective view of another embodiment of a seed meter.

FIG. 20 is a side elevation view of the reservoir side of the seed disc in FIG. 18a.

FIG. 21 is a perspective view of the vacuum side of the seed disc in FIG. 18a.

FIG. 22 is a perspective view of the vacuum housing of the seed meter in FIG. 18a.

FIGS. 23 a and 23b are sectional perspective views

of an embodiment of the interface between the seed disc and the seed meter housing.

[0021] Before any independent features and embodiments of the invention are explained in detail, it is to be understood that the invention is not limited in its application to the details of the construction and the arrangement of the components set forth in the following description or illustrated in the drawings. The invention is capable of other embodiments and of being practiced or of being carried out in various ways. In addition, it is understood that the phraseology and terminology used herein is for the purpose of description and should not be regarded as limiting.

DETAILED DESCRIPTION OF THE PREFERRED EMBODIMENTS

[0022] Referring to FIG. 1, a conventional planter row unit 10 with an air seed meter 5 is shown. The row unit 10 and air seed meter 5, as shown in FIGS. 1 and 2, is known in its general aspects to persons skilled in the art. The row unit 10 includes a U-bolt mount 11 for mounting the row unit 10 to a planter frame or tool bar (not shown), as it is sometimes called, which may be a steel tube of 5 by 7 inches (although other sizes are used). The mount 11 includes a faceplate 12, which is used to mount left and right parallel linkages. Each linkage may be a four-bar linkage, such as the left one 14 shown in FIG. 1. It is noted that the opposite (right) linkage is generally a mirror image of the linkage 14 shown in FIG. 1. The double linkage is sometimes described as having upper parallel links and lower parallel links, and the rear ends of all four parallel links are pivotally mounted to the frame 15 of the row unit 10. The frame 15 includes a support for an air seed meter 5 and seed hopper 16, as well as a structure including a shank 17 for mounting a pair of ground-engaging gauge wheels 18. The frame 15 is also mounted to a furrow-closing unit 19, which includes a pair of inclined closing wheels 19a, 19b. The row unit 10 also includes a pair of furrow opener discs 9, as shown in FIG. 2.

[0023] FIG. 3 and FIG. 4 represent a seed meter 20 according to an exemplary embodiment of the invention. The seed meter 20 of FIG. 3 and FIG. 4 includes a seed meter housing 21, which contains the seed disc 22 and central hub 25. The seed disc 22 and central hub 25 are exposed for illustration purposes, but would normally be concealed behind a vacuum housing 200 attached to the seed meter housing 21. The vacuum housing 200, shown in FIG. 6 and FIG. 7, also includes a vacuum inlet 202 for a vacuum or other air source (not shown), an aperture 204 to allow seed disc central hub 25 to pass through, and attachment means 206 (shown to be keyhole slots) at an outer area of the vacuum housing 200. The seed meter housing 21 and the vacuum housing 200 may be molded, such that they comprise molded plastic or other rigid materials.

[0024] Seed is conveyed into a reservoir 26 on the seed

meter housing 21 via an input tube (not shown) or a seed hopper (FIG. 1). Once in the reservoir 26, the seed pools adjacent the seed disc 22 near the bottom or lower portion of the seed meter housing 21 and becomes attached to the seed disc 22 as the seed disc 22 is rotated by direct drive 27. The interior of the seed meter housing 21 without the seed disc 22 is shown in FIG. 5, which also shows the location of the reservoir 26 inside the seed meter housing 21. A door 167, which may be slidable or otherwise movable, may be positioned adjacent the reservoir opening to provide access to the reservoir 26 to aid in emptying or cleaning out the reservoir 26. FIG. 5 also shows the location and configuration of a singulator 111, which is used to prevent multiple seeds becoming attached at a single seed cell 54. The singulator 111 is shown in FIGS. 14-17. Seeds are then released from the seed disc 22 as they transition through a zone 30 of the seed meter 20 having little to no pressure differential. Seeds are dropped into the seed chute 24, which delivers them to the furrow.

[0025] The vacuum housing 200, as shown in FIG. 6 and FIG. 7, includes a vacuum inlet 202, which is connected to a vacuum source (not shown), such as a vacuum impeller, via vacuum hoses (not shown). The seed meter housing 21 includes a plurality of bosses 32 disposed along its periphery, as shown in FIG. 3. The plurality of bosses 32 are configured to extend through the attachment means 206 of the vacuum housing 200 to locate the vacuum housing and, after rotation by the user, restrain it in place against the seed meter housing 21. The attachment means 206 of the vacuum housing 200 are shown to be keyhole slots, but any other configuration can be used. The vacuum housing 200 further includes a sealing member 208 fitted into a groove on the interior of the vacuum housing 200. The sealing member 208 contacts the seed flange 51 of the vacuum side of the seed disc 22 (see, for example, FIGS. 8 and 9) to define a vacuum chamber 210 in communication with the vacuum inlet 202. The sealing member 208 is also surrounded by an annular rim 162 of the seed disc 22 to improve suction at the seed cells 54. As seed cells 54 move into the vacuum chamber 210, they are placed in fluid communication with the vacuum source. A plurality of apertures 211 in the chamber 210 provide for suction from the vacuum source along the length of the chamber 210.

[0026] Also mounted to the inside of the vacuum housing 200 is a remnant ejector 212 for the removal of seeds or seed remnants from a seed cell 54 after the seed cell passes the seed chute 24 and is no longer in communication with the vacuum chamber 210. The remnant ejector 212 is housed within an ejector housing 215 formed integrally with the vacuum housing 200. However, the ejector housing 215 may also be removable so as to allow different ejectors to be used according to different seed discs and seed types. The remnant ejector 212 interfaces with a series of seed cells 54 from the vacuum side of the seed disc (shown in FIGS. 3 and 8). The remnant ejector 212 includes a rotatable wheel 214 with a plurality

of punches 216 about its periphery to remove seeds, seed debris, or other remnants remaining in a seed cell 54 after it passes the seed chute 24. The remnant ejector 212 is spring-biased towards the seed disc 22 and moves synchronously with the seed disc 22 as it is rotated, i.e., the rotation of the seed disc 22 rotates the wheel 214 of the remnant ejector 212. Furthermore, the remnant ejector 212 is rotatable about legs 218 to allow the ejector to move relative to the biasing spring, which aids in pressing the punches 216 of the wheel 214 to remain biased against the seed cells 54 of the seed disc 22.

[0027] FIG. 8 illustrates the vacuum side of the seed disc 22. The seed disc 22 is substantially cylindrical and has opposing sides - a vacuum side shown in FIGS. 3 and 8, and a reservoir side, which contacts a pool of seed (FIG. 12). It should be noted that the "vacuum side" generally refers to the side of the disc 22 that will be adjacent the vacuum source. The seed disc 22 comprises a molded plastic or other rigid material. The seed disc 22 has a cross-sectional profile as shown in FIG. 9. The cross-sectional profile of the seed disc 22 shows at least two zones on the seed disc 22. The first zone is a generally flat seed flange 51 located at or near the outer radius of the seed disc 22. A series of seed cells 54 located at the seed flange 51 comprise apertures extending from the vacuum side to the reservoir side, and are spaced radially about the circumference of the seed disc, which is generally a circle. The aperture of the seed cells 54 may be larger on the vacuum side of the disc 22 and narrow through the disc 22 such that the negative pressure on the seed side of the disc 22 is increased. Alternatively, a single-sized aperture may form the seed cell 54. The seed flange 51 also includes an annular rim 162 extending radially outward from the plurality of seed cells 54 and which will be described later in further detail. Although in the embodiment shown in FIG. 8 a single seed cell circle is shown with seed cells 54 being positioned at an equal radius, one skilled in the art may also appreciate that seed cells could be staggered about multiple circles to create an alternating pattern. It should also be appreciated that the spacing and size of the seed cells 54 may be changed from the illustrated embodiments to accommodate different seed types and planting methods. The present seed disc and seed cells are not to be limited to the embodiments shown and described.

[0028] A second zone 52 is shown by the cross-sectional profile of the seed disc 22. The second zone is contoured and located radially inward of the seed flange 51. The second zone 52 includes a cylindrical internal flange 55. The internal flange 55 is formed substantially perpendicular to the seed flange 51 and is substantially concentric with the center axis of the seed disc 22. The interior sidewall of the cylindrical interior flange 55 includes four keyways 53 running longitudinally through the interior flange 55 and spaced evenly about the inner circumference of the flange 55. The cross-section of the keyways 53 is substantially similar to the external profile of the hub protrusions 61 as shown in FIG. 10. While four

keyways are shown in the figures, it should be appreciated that generally any number of keyways are contemplated for use with the seed disc 22 of the exemplary embodiment. When more or less keyways are used with a seed disc, the keyways can be radially spaced around the axis of the disc, or can otherwise be positioned to align with at least as many hub protrusions 61 for connecting the hub to the seed disc.

[0029] The seed disc 22 can be fixed within the seed meter 20 without the use of fasteners or tools by inserting the central hub 25 of the seed meter housing 21 through the aperture 56 created by the inner flange 55 of the seed disc 22. The keyways 53 of the inner flange 55 are shaped and aligned at 90-degree intervals to receive the protrusions 71 of the hub 25 (see, e.g., FIG. 10). With the central hub 25 inserted through the inner flange 55, the protrusions will emerge from the keyways 53. The hub 25 can then be rotated in the direction shown by the embossed arrows 57 (see, e.g., FIG. 8), while the seed disc 22 is restrained, such that the protrusions 71 will engage recesses or notches 81 on the rim of the interior flange 55 of the seed disc 22, as shown in FIG. 11. The seed disc 22 could also be rotated while the hub 25 is restrained to lock and unlock. The central hub 25 slidably mounts to a first end of a shaft 40 to fix the position of the seed disc 22 within the seed meter housing 21. The central hub 25 is retained in place by an upper roll pin 42 passing through an aperture on the shaft 40 and lower dowel pin, located on the shaft 40, which may otherwise be the protrusions 71 of the hub 25. The second, opposite end of shaft 40 is rotatably and axially coupled to an integrated shaft bearing. The shaft bearing (not shown) may be a plain bearing, such as generally any cylindrical sleeve made of a low friction material, a rolling-element bearing, which uses spheres or small cylinders that rotate or roll between a shaft and the mating parts to reduce friction and allow much tighter mechanical tolerances, or a water pump-style bearing. The shaft bearing is positioned in a cavity 44, as shown FIG. 4. It should be appreciated that when other numbers of keyways 53 are used to aid in attaching the seed disc 22 to the seed meter 20, the keyways may be located at other angles, such that the disc 22 or hub 25 can be rotated more or less to engage the protrusions with the recesses. Turning now to the reservoir side of the seed disc 22, which is shown in FIG. 12, a plurality of recesses or channels 91 are shown formed in the seed flange 51. On the reservoir side of the seed disc 22, the seed flange 51 includes a portion extending from the face of the disc 22 and including an inner lip 96 and an outer chamfer 94. The outer chamfer 94 may be beveled or other angular in relation to the face of the seed disc 22. FIG. 13 shows an enlarged view of these recesses or channels 91. A recess or channel 91 is present for and respectfully aligned to a seed cell 54. The recess or channel 91 is positioned substantially forward of its corresponding seed cell 54 with respect to the rotational direction (as shown by the arrow 93 of FIG. 12) of the seed disc 22 during operation and provides agitation of

seed in a seed pool when the seed disc 22 is rotated. The channel 91 is oriented at an oblique angle with respect to the radius line that passes through the center of corresponding seed cell 54. This angle directs seed radially outward and rearward with respect to the rotational direction 93 of the seed disc 22 during operation, such that seed is guided towards the seed cells 54. The channels 91 as shown are substantially rectangular in shape, but could be also comprise an oval or any other shape that would aid in the directing of seed towards seed cells 54. It should also be appreciated that the shape and configuration of the channels can aid in loosening seeds in the reservoir, while also guiding them towards the seed cells 54. Furthermore, the channels or recesses include a ramped portion 97 generally adjacent the seed cell 54, which is used to position the seed at the seed cell 54 during rotation of the seed disc 22.

[0030] Therefore, the channels 91 of the seed disc 22 provide numerous advantages. As the channels 91 are generally recessed areas separated by wall-like portions, they will increase agitation of the seed pool to promote the movement of the seeds from the seed pool. The recessed channels 91 will also provide a direct path from the seed pool to the seed cells 54, which will promote good adhesion between the seed and the seed disc 22 at the seed cells 54. This will aid in increasing the accuracy of the seed meter by increasing the likelihood that a seed will be adhered to the seed cell 54. As the channels 91 are formed integrally with the seed disc 22, they can be configured and numbered to match generally any number of seed cells 54 and can be oriented or sized to best match with any type of seed. In the alternative, one single channel 91 size and orientation may be configured such that it is usable with all types of seed. In addition, the reservoir side of the seed disc 22 will include an outer chamfer 94 and an extension surface 95, which extends generally from the outer chamfer 94 to the annular lip 162 on the periphery of the seed disc 22. The outer chamfer 94 essentially forms a "false edge" of the seed disc 22, to better position the seed at or near the edge for better consistency during release of the seed into the chute 24. During rotation of the seed disc 22, and after the seeds have adhered to the seed cells 54, the disc 22 will continue to rotate until a seed passes the zone 30 of the seed meter 20 with little to no pressure differential. At this location, the outer chamfer 94 will be directly adjacent the outer wall of the seed meter housing 21, which positions the seed and seed cell 54 at the false "outer edge" of the seed disc 22. Thus, the seed will become disengaged from the seed cell at the outer edge, which will decrease the likelihood of ricochet or bounce as the seed passes through the chute 24, thereby increasing seed spacing consistency. The length of the extension surface 95 will vary based upon factors such as the amount of offset 161, the type of seed, how close the seed cells 54 need to be to the "edge", as well as other factors. The creation of the "false edge" provides for the seed to be released at or near the "edge" of the seed

disc 22, while still providing enough suction as the disc 22 passes adjacent the seed pool, as will be discussed below.

[0031] In situations where duplicate seeds may be drawn onto or against a single seed cell 54, a singulator 111, such as that shown in FIGS. 5, 14, 15, and 17 can be used. The singulator 111 is configured to remove the excess seed(s) from the seed cell. The singulator 111 is mounted at and operatively connected to the seed meter housing 21 such that a first blade 112 (shown most clearly in FIG. 17) and a second blade 113 is adjacent to the reservoir side face of the seed flange 51 and the seed cells 54. The blades are spaced from the face of the seed disc 22, as well as the flange 51 and seed cells 54. The blades 112, 113 may be configured such that they are on opposite sides of the seed cell circle. The singulator 111 is biased towards the axis of the seed disc 22 and/or seed meter housing 21. The biasing towards the axis of the seed disc 22 and/or seed meter housing 21 may be provided by a spring, gravity, or other tension member, such as by attaching the singulator 111 by a wire to the seed meter housing 21. The singulator 111 is configured to have a fixed, curved rim portion 119 that at least partially surrounds the annular rim 162 of the seed disc, which aids in positioning the singulator 111 adjacent the seed cells 54. The first blade 112 is positioned adjacent to the backside of the curved rim 119, i.e., the side furthest from the seed disc 22, and radially outward of the seed cell 54 circle. The first blade 112 includes an inner edge with a first set of ramps 115 and a generally curved profile similar to the circumference of the seed cell circle. Biasing the singulator 111, including first blade 112, generally inward towards the axis, aids in keeping the blade 112, and thus, the ramps 115, at the outer edge of the seed disc 22 to position the blade 112 and ramps 115 adjacent an outer area of the seed cells 54. This aids in removing additional seeds at the seed cells 54 so that one seed is positioned at a seed cell 54.

[0032] The second blade 113 is spaced from the first blade 112 and is positioned radially inward of the seed cell circle 54. The second blade 113 includes an inner edge (closest to the seed cell circle) with a second set of ramps 116. It should be appreciated that the singulator 111 could have other ramp configurations for different seed types and the profile of the blades are not to be limiting to the exemplary embodiment. For example, smaller seeds such as a soybean seed may need less aggressive singulation and, therefore, fewer or smaller ramps can be used than for larger seeds like corn. It should also be appreciated that first blade 112 and second blade 113 could be comprised of a plurality of individual ramp assemblies, capable of moving independent of or in relationship with one another. For instance, a first ramp on first blade 112 could move independent of or in relationship with a second ramp on first blade 112, or a first ramp on first blade 112 could move independent of or in relationship with a first ramp on second blade 113.

[0033] The first blade 112 and second blade 113 are

attached to first and second carriages, 121 and 122. In addition, the first and second blades 112, 113 may be formed integrally with the carriages 121, 122. The blades 112, 113 may be attached to the carriages 121, 122 such that they can be replaced after wear and tear, or due to a change in the type of seed being using with the system. Therefore, screws, or other temporary attachments may be used to at least temporarily attach the blades to the carriages.

[0034] The first and second carriages, 121 and 122, are manipulated via a rotary adjustment 114 in a manner such that the first blade 112 adjusts radially outward as the second blade 113 simultaneously adjusts radially inward or vice versa, thus changing the width of the seed path between the first and second blades 112, 113 for the seed cells 54 to pass through. The second blade 113 is connected to the rotary adjustment 114 via a cam or other mechanism that converts the rotational movement of the rotary adjustment 114 to a translational movement of the first 112 and/or second blade 113. Thus, the second blade 113 (and/or first blade 112) moves generally towards or away from the first blade 112 in a longitudinal manner as the rotary adjustment is rotated. For example, the blades 112, 113 may be slidably connected such that the blades slide along guides, slots, or notches in the singulator 111. However, it is not required that both carriages, and thus, both blades move with rotation of the rotary adjustment 114. For example, it is contemplated that only one of the blades move when the rotary adjustment 114 is rotated to either widen or narrow the distance between the blades, and thus, the ramps on the blades. Furthermore, the curved rim 119 remains fixed while the first blade 112 moves to ensure positioning of the singulator 111 adjacent the seed cells 54.

[0035] A wider seed path typically allows for less aggressive singulation, i.e., less contact by a ramp 115, 116 with a seed(s) in the seed cell 54. A narrower seed path typically creates more aggressive singulation, i.e., more contact by a ramp 115, 116 of a seed(s) in a seed cell 54. The level of aggressiveness is determined based on a number of factors, including, but not limited to, seed size, rate of seed dispensing, type of seed, and/or the amount of suction present at the seed cell 54. However, the singulator 111 is generally configured such that only one seed is drawn onto or against the seed cell 54 and any other seeds drawn onto or against the seed cell 54 are knocked off into the seed pool. The slot 28 in the housing allows an operator to easily access the rotary adjustment 114, so as to adjust the width of the seed path between the first and second blades 112, 113 without removal of any parts. This allows the singulator 111 to be used in the seed meter 20 with a variety of types of seeds, e.g. corn, bean, etc., while also allowing quick and easy adjustment for the width of the path between the blades.

[0036] FIG. 16 illustrates a view of the face of the rotary adjustment 114. On the face are cam grooves 131 and 132. These grooves 131, 132 vary in radial distance from

the center axis 134 of the rotary adjustment 114. Rotating the rotary adjustment 114 causes the first and second carriages 121, 122 (and thus, first and second blades 112, 113) to move in a linear direction either toward or away from the axis of the seed disc 22, which changes the width of the path between the blades 112, 113 such that the blades can be used with different types and sizes of seeds. With the carriages restricted to linear motion, the engagement of the carriage protrusions, 141 and 142, with the cam grooves, 131 and 132, causes the carriages to change position relative to the rotation of the rotary adjustment 114. The carriages 121, 122, and protrusions 141, 142 can be seen in FIG. 17. However, as noted above, when only one of the blades 112, 113 is to be moved, only one set of grooves can be included on the face of the rotary adjustment 114 such that rotation thereof causes the protrusion in engagement with the groove to move linearly.

[0037] The singulator 111 can also be a removable carriage from the seed meter housing 21 to allow the singulator 111 to be repaired, replaced, cleaned, adjusted, etc. The singulator 111 includes attachment means 117, such as feet extending generally from the bottom side of the singulator 111. The feet 117, which are shown for exemplary purposes, are configured to fit into slots 118 (see FIG. 5) formed integrally with or attached to the inside of the seed meter housing 21. Therefore, to remove the singulator 111, a set of snaps on the singulator are disengaged, allowing the singulator to be rotated and the feet 117 to remove from the slots 118 in the seed meter housing 21, and removing the rotary adjustment 114 through an aperture in the seed meter housing 21. To replace the singulator 111, the feet 117 are positioned in the slots 118, and the rotary adjustment 114 is positioned through the aperture in the seed meter housing 21 to provide access for a user to adjust the spacing between the first and second blades 112, 113. Furthermore, any number or configuration of snaps or other members may be added to the singulator body and/or housing to aid in retaining the singulator in place in the seed meter housing 21.

[0038] In another embodiment of a singulator mechanism, which is shown generally in FIG. 15a, the singulator 111 does not include a set of snaps and feet 117, but instead is secured to and within the seed meter housing 21 by a tension member 120, such as a flat spring. In this manner, the singulator 111 can be removed from the housing by sliding clips 120a upwardly and then towards the user with respect to boss 120b. Singulator 111 can then be removed from the seed meter housing 21 for repair, replacement, cleaning and adjustment. In other embodiments using the tension member 120, protrusions may extend from the interior of the seed meter housing 21, with apertures of the tension member 120 simply snapping to or otherwise fitting on the protrusions to at least temporarily secure the singulator 111 to the seed meter housing 21.

[0039] FIG. 18 provides an illustration of the interaction

between the unique drive 27 and the seed disc 22 according to an exemplary embodiment of the invention. A portion of the seed meter 20 has been sectioned away to show internal components of the assembly. As shown in FIG. 18, the unique drive 27 is mounted externally to the seed meter housing 21 such that an output shaft 154 of the drive 27 protrudes through at least a portion of the seed meter housing 21 perpendicular to and adjacent the face of the reservoir side of seed disc 22. An external gear 153 is mounted on or otherwise forms a portion of the output shaft 154. Integrally molded into, or attached to in some embodiments, the reservoir side of the seed disc 22 is an internal gear feature 152. Said internal gear 152 and said external gear 153 are positioned such that their matching gear teeth engage each other. This engagement allows direct control of the rotational speed of the seed disc 22 via control of the unique drive's 27 rotational output speed of the output shaft 154. In an exemplary embodiment, the unique drive 27 is powered by an electric motor 151, but one skilled in the art may appreciate that the unique drive could also derive its power from a pneumatic or hydraulic rotary motor, as well as any other type of rotary motion, including but not limited to, mechanical, cable drive, or chain.

[0040] In another embodiment of a seed meter, as shown in FIG. 19, the unique drive 27a is mounted externally to the vacuum housing 200a such that the output shaft 154a protrudes through the vacuum housing 200a substantially perpendicular to and adjacent the face of the vacuum side of the seed disc 22. An external gear 153a is mounted on or otherwise forms a portion of the output shaft 154a. Integrally molded into the vacuum side of the seed disc 22a is an internal gear feature 152a. The internal gear feature 152a may also be a separate element that is attached to an internal ring or flange of the vacuum side of the seed disc 22a. Said internal gear feature 152a and said external gear 153a are positioned such that their matching gear teeth engage each other such that the output of the unique drive 27a rotates the seed disc 22a. FIGS. 20-22 further depict the seed disc 22a and vacuum housing 200a of the modified embodiment.

[0041] The control of the speed of the unique drive 27, 27a, and thus seed disc 22, 22a, allows for the spacing of the seeds during planting to be better controlled. As noted, the rotational velocity of the seed disc 22, 22a in relation to the speed of travel of the tractor or other equipment aids in controlling the distance between seeds in a row. Therefore, the addition of the unique drive 27, 27a allows an operator to control the distance by simply adjusting control of the drive 27, 27a. For example, an operator in a tractor could adjust the rotational speed via remote or other control interface such that the distance between seeds could be adjusted during planting. This can result in significant time savings, as the operator does not have to stop planting to adjust seed rate of the meter, thus allowing a field to be efficiently planted with varied planting conditions.

[0042] Referring to FIGS. 23a and 23b, an enlarged and sectional view of the seed meter 20 is shown detailing the interface between the seed disc 22 and the seed meter housing 21. In certain areas, an offset portion 161 of the outer sidewall 163 is provided to be eccentric with the outer circumference (e.g., annular rim 162) of the seed disc 22. A relief member 165, which is also shown in FIG. 5, covers the space created by the offset portion 161 between the seed cell 54 of the seed disc 22 and the bottom edge of outer sidewall 163. For example, as shown in FIG. 23a, the offset portion 161 is eccentric with the seed disc 22 at the loading zone 166, i.e., the area of the seed meter 22 where the seed pools and is agitated prior to being drawn onto or against a seed cell 54. The area created by offset portion 161 and covered by the relief member 165 gives the seed additional room to move about and be drawn onto or against the seed cell 54, which reduces the likelihood of the seed being knocked free from the seed cell 54 by the seed meter housing 21 during rotation of the seed disc 22. The relief member 165 also aids in orienting the seed in the seed cell 54 such that a greater surface area of the seed will fit in the cell 54 to provide the strongest suction on the seed at the cell 54.

[0043] The relief member 165 essentially creates a false outer wall of the seed meter housing 21. As mentioned above and shown best in FIGS. 12 and 13, the reservoir side of the seed disc 22 will include an outer chamfer 94 and an extension 95 that ends at the annular rim 162 of the seed disc 22. As mentioned above, the outer chamfer 94 and extension 95 creates a false edge for the seed disc 22, which allows the seed cells 54 to be positioned generally at the outer edge of the false edge. While the false edge created by the outer chamfer 94 and extension 95 aids in releasing seed, they can make it difficult for the seed to attach to a seed cell 54 at the seed pool due to the decreased suction at the outer edge of the seed disc 22. The offset portion 161 and relief member 165 counteract this by creating a "false wall". The so-called false wall created by the relief member 165 will extend from the outer chamfer 94 to the outer wall of the seed meter housing 21. The width of the false wall (relief member 165) will make it appear as though the seed is being attached at a location further inward on the seed disc 22, with the relief member providing a barrier to create more suction at the seed cell 54 to increase the consistency of seed attaching to the seed cells 54. The relief member 165 and offset 161 can extend to the entrance of the singulator 111, which is used to ensure that only one seed is positioned at each seed cell 54.

[0044] An air seed meter for dispensing seed in a field has been provided. The exemplary embodiments shown and described contemplate numerous variations, options, and alternatives, and are not to be limited to the specific embodiments shown and described herein. For example, the improvements described herein are equally applicable to other meters, such as positive-air meters like that disclosed in U.S. Patent No. 4,450,959. The fore-

going description has been presented for purposes of illustration and description, and is not intended to be exhaustive list or to limit the exemplary embodiment to precise forms disclosed. It is contemplated that other alternative processes obvious to those skilled in the art are considered to be included in the invention within the scope of the appended claims.

10 Claims

1. An air seed meter (20) for an agricultural planter, comprising:
 - a housing (21) defining a seed reservoir (26), a discharge chute (24), and a vacuum chamber (200); and
 - a seed disc (22) mounted in said housing (21) for rotation about an axis and having a plurality of seed cells (54) spaced radially about the axis for retaining seeds, said seed disc (22) having channels (91) adjacent to each respective seed cell (54); **characterized in that** said seed cells (54) and channels (91) are positioned at a flanged portion (51) including a portion extending from a face of the seed disc (22) and including an inner lip and an outer chamfer.
2. The air seed meter of claim 1 wherein each respective channel (91) is substantially inside of the seed cells (54) and each channel (91) being forward of each corresponding seed cell (54) with respect to a rotational direction (93) of the seed disc (22).
3. The air seed meter of claim 2 wherein each respective channel (91) has a length greater than a width of the channel (91).
4. The air seed meter of claim 2 wherein each respective channel (91) is oriented on the seed disc (22) such that the length of the channel (91) is at an oblique angle to a radius line of the channel's corresponding seed cell (54) such that an inner forward corner of the channel (91) leads an outer forward corner with respect to the direction of rotation (93).
5. The air seed meter of claim 4 wherein a face of the channel (91) is tangential to a forward inner edge of the seed cell (54).
6. The air seed meter of claim 1 wherein the outer chamfer (94) is beveled or otherwise angular in relation to the seed disc (22).
7. The air seed meter of claim 6 wherein the seed cells (54) comprise apertures through the flanged portion (51) of the seed disc (22).

8. The air seed meter of claim 6 wherein the channels (91) comprise recessed portions of the flanged portion (51) of the seed disc (22).
9. The air seed meter of claim 8 wherein the channels (91) comprise a ramped portion (97) forward of and adjacent the seed cell (54) and configured to aid in directing a seed to the seed cell (54) during rotation of the seed disc (22).
10. The air seed meter of claim 8 wherein the seed disc (22) further comprises an extension surface from the outer chamfer (94) to an annular rim (162), wherein the annular rim (162) includes a lip extending away from the flanged portion (51).
11. The air seed meter of claim 1 wherein
the seed disc (22) is housed between the seed meter housing (21) and the vacuum chamber housing (200);
the seed disc (22) comprises a substantially circular member having a first side adjacent the seed meter housing (21) and a second side adjacent the vacuum chamber housing (200), the seed cells (54) comprise apertures through the disc and spaced radially a distance from an axis of the substantially circular member; and
said first side of the circular member comprising the plurality of channels (91) arranged in a radial array about the axis of the substantially circular member such that a respective channel (91) is substantially radially inward and forward of a corresponding aperture;
wherein the channels (91) are configured to move seed adjacent a channel and to an aperture for retention until release therefrom.
12. A seed disc (22) for use with an air seed meter (20) of an agricultural implement, comprising:

a cylindrical structure having first and second sides and containing a plurality of seed cells (54) therethrough, said seed cells (54) being arranged in a radial array a distance from an axis of the cylindrical structure;
a plurality of channels (91) arranged in a radial array and positioned about the axis of the cylindrical structure on the first side of the structure such that a respective channel (91) is substantially radially inward and forward of a corresponding seed cell (54); and a central cylindrical aperture (56) therein for mounting to said seed meter (20), **characterized in that** the seed cells (54) and the channels (91) are positioned at a flanged portion (51) including a portion extending from a face of the seed disc (22) and including an inner lip and an outer chamfer.

13. The seed disc of claim 12 further comprising an inward facing annular gear positioned about the central cylindrical aperture (56).

Patentansprüche

1. Pneumatische Saatgutvereinzelungsvorrichtung (20) für eine landwirtschaftliche Sämaschine, die Folgendes aufweist:

ein Gehäuse (21), das einen Saatgutspeicher (26), eine Austragsrutsche (24) und eine Vakuumkammer (200) definiert; und
eine Saatgutscheibe (22), die zur Drehung um eine Achse in dem genannten Gehäuse (21) montiert ist und mehrere Saatgutzellen (54) hat, die zum Festhalten von Saatgut radial um die Achse beabstandet angeordnet sind, wobei die genannte Saatgutscheibe (22) an jede jeweilige Saatgutzelle (54) angrenzende Kanäle (91) hat; **dadurch gekennzeichnet, dass** die genannten Saatgutzellen (54) und Kanäle (91) an einem geflanschten Teil (51) positioniert sind, der einen Teil enthält, der sich von einer Stirnfläche der Saatgutscheibe (22) erstreckt und eine innere Lippe und eine äußere Schräge enthält.
2. Pneumatische Saatgutvereinzelungsvorrichtung nach Anspruch 1, wobei jeder jeweilige Kanal (91) sich im Wesentlichen im Inneren der Saatgutzellen (54) befindet und jeder Kanal (91) in Bezug auf eine Drehrichtung (93) der Saatgutscheibe (22) vor jeder entsprechenden Saatgutzelle (54) ist.
3. Pneumatische Saatgutvereinzelungsvorrichtung nach Anspruch 2, wobei jeder jeweilige Kanal (91) eine Länge hat, die größer als eine Breite des Kanals (91) ist.
4. Pneumatische Saatgutvereinzelungsvorrichtung nach Anspruch 2, wobei jeder jeweilige Kanal (91) so an der Saatgutscheibe (22) ausgerichtet ist, dass die Länge des Kanals (91) in einem schiefen Winkel zu einer Radiuslinie der entsprechenden Saatgutzelle (54) des Kanals ist, so dass eine innere vordere Ecke des Kanals (91) in Bezug auf die Drehrichtung (93) vor einer äußeren vorderen Ecke liegt.
5. Pneumatische Saatgutvereinzelungsvorrichtung nach Anspruch 4, wobei eine Stirnfläche des Kanals (91) zu einem vorderen inneren Rand der Saatgutzelle (54) tangential ist.
6. Pneumatische Saatgutvereinzelungsvorrichtung nach Anspruch 1, wobei die äußere Schräge (94) in Bezug auf die Saatgutscheibe (22) stumpfwinklig ist oder anderweitig winklig ist.

7. Pneumatische Saatgutvereinzelungsvorrichtung nach Anspruch 6, wobei die Saatgutzellen (54) Durchgänge durch den geflanschten Teil (51) der Saatgutscheibe (22) aufweisen.
8. Pneumatische Saatgutvereinzelungsvorrichtung nach Anspruch 6, wobei die Kanäle (91) ausgesparte Teile des geflanschten Teils (51) der Saatgutscheibe (22) aufweisen.
9. Pneumatische Saatgutvereinzelungsvorrichtung nach Anspruch 8, wobei die Kanäle (91) einen rampenförmigen Teil (97) vor und neben der Saatgutzelle (54) aufweisen und gestaltet sind, um beim Lenken eines Saatkorns zur Saatgutzelle (54) während der Drehung der Saatgutscheibe (22) behilflich zu sein.
10. Pneumatische Saatgutvereinzelungsvorrichtung nach Anspruch 8, wobei die Saatgutscheibe (22) ferner eine Verlängerungsfläche von der äußeren Schräge (94) zu einem ringförmigen Rand (162) aufweist, wobei der ringförmige Rand (162) eine Lippe aufweist, die sich von dem geflanschten Teil (51) aberstreckt.
11. Pneumatische Saatgutvereinzelungsvorrichtung nach Anspruch 1, wobei die Saatgutscheibe (22) zwischen dem Gehäuse (21) der Saatgutvereinzelungsvorrichtung und dem Vakuumkammergehäuse (200) untergebracht ist; die Saatgutscheibe (22) ein im Wesentlichen kreisförmiges Element aufweist, das eine erste Seite neben dem Gehäuse (21) der Saatgutvereinzelungsvorrichtung und eine zweite Seite neben dem Vakuumkammergehäuse (200) hat, wobei die Saatgutzellen (54) Durchgänge durch die Scheibe aufweisen und radial in einem Abstand von einer Achse des im Wesentlichen kreisförmigen Elements angeordnet sind; und die genannte erste Seite des kreisförmigen Elements die mehreren Kanäle (91) aufweist, die in einer radialen Gruppierung um die Achse des im Wesentlichen kreisförmigen Elements angeordnet sind, so dass ein jeweiliger Kanal (91) im Wesentlichen radial einwärts von und vor einem entsprechenden Durchgang ist; wobei die Kanäle (91) zum Bewegen von Saatgut neben einem Kanal und zu einem Durchgang zur Festhaltung, bis sie daraus ausgelöst werden, gestaltet sind.
12. Saatgutscheibe (22) zur Verwendung mit einer pneumatischen Saatgutvereinzelungsvorrichtung (20) eines landwirtschaftlichen Geräts, die Folgendes aufweist:

eine zylindrische Konstruktion, die eine erste und eine zweite Seite hat und mehrere Saatgutzellen (54) durch sie hindurch enthält, wobei die genannten Saatgutzellen (54) in einer radialen Gruppierung in einem Abstand von einer Achse der zylindrischen Konstruktion angeordnet sind; mehrere Kanäle (91), die in einer radialen Gruppierung angeordnet sind und um die Achse der zylindrischen Konstruktion auf der ersten Seite der Konstruktion positioniert sind, so dass ein jeweiliger Kanal (91) im Wesentlichen radial einwärts und vor einer entsprechenden Saatgutzelle (54) ist; und einen zentralen zylindrischen Durchgang (56) darin zum Montieren an der genannten Saatgutvereinzelungsvorrichtung (20), **dadurch gekennzeichnet, dass** die Saatgutzellen (54) und die Kanäle (91) an einem geflanschten Teil (51) positioniert sind, der einen Teil enthält, der sich von einer Stirnfläche der Saatgutscheibe (22) erstreckt und eine innere Lippe und eine äußere Schräge enthält.

13. Saatgutscheibe nach Anspruch 12, die ferner einen nach innen gekehrten Zahnkranz aufweist, der um den zentralen zylindrischen Durchgang (56) positioniert ist.

Revendications

1. Doseur de graines pneumatique (20) pour une plante agricole, comprenant :
- un logement (21) définissant un réservoir à graines (26), une goulotte de décharge (24), et une chambre à vide (200) ; et
- un disque à graines (22) monté dans ledit logement (21) pour une rotation autour d'un axe et ayant une pluralité de cellules à graines (54) espacées radialement autour de l'axe pour retenir des graines, ledit disque à graines (22) ayant des canaux (91) adjacents à chaque cellule à graines respective (54) ; **caractérisé en ce que** lesdites cellules à graines (54) et les canaux (91) sont positionnés au niveau d'une partie en bride (51) incluant une partie s'étendant à partir d'une face du disque à graines (22) et incluant une lèvre interne et un chanfrein externe.
2. Doseur de graines pneumatique de la revendication 1 dans lequel chaque canal respectif (91) se trouve substantiellement à l'intérieur des cellules à graines (54) et chaque canal (91) se trouvant à l'avant de chaque cellule à graines correspondante (54) par rapport à un sens rotationnel (93) du disque à graines (22).
3. Doseur de graines pneumatique de la revendication

- 2 dans lequel chaque canal respectif (91) a une longueur qui est plus grande qu'une largeur du canal (91).
4. Doseur de graines pneumatique de la revendication 2 dans lequel chaque canal respectif (91) est orienté sur le disque à graines (22) de telle sorte que la longueur du canal (91) soit située à un angle oblique par rapport à une ligne de rayon de la cellule à graines correspondante du canal (54) de telle sorte qu'un coin avant interne du canal (91) mène un coin avant externe par rapport au sens de rotation (93).
5. Doseur de graines pneumatique de la revendication 4 dans lequel une face du canal (91) est en tangente par rapport à un bord interne avant de la cellule à graines (54).
6. Doseur de graines pneumatique de la revendication 1 dans lequel le chanfrein externe (94) est biseauté ou autrement angulaire relativement au disque à graines (22).
7. Doseur de graines pneumatique de la revendication 6 dans lequel les cellules à graines (54) comprennent des ouvertures à travers la partie en bride (51) du disque à graines (22).
8. Doseur de graines pneumatique de la revendication 6 dans lequel les canaux (91) comprennent des parties en retrait de la partie en bride (51) du disque à graines (22).
9. Doseur de graines pneumatique de la revendication 8 dans lequel les canaux (91) comprennent une partie en rampe (97) à l'avant de et adjacente à la cellule à graines (54) et configurée de façon à aider à diriger une graine vers la cellule à graines (54) durant la rotation du disque à graines (22).
10. Doseur de graines pneumatique de la revendication 8 dans lequel le disque à graines (22) comprend en outre une surface d'extension depuis le chanfrein externe (94) jusqu'à une jante annulaire (162), la jante annulaire (162) incluant une lèvre qui s'étend en éloignement par rapport à la partie en bride (51).
11. Doseur de graines pneumatique de la revendication 1 dans lequel le disque à graines (22) est logé entre le logement de doseur de graines (21) et le logement de chambre à vide (200) ; le disque à graines (22) comprend un élément substantiellement circulaire ayant un premier côté adjacent au logement de doseur de graines (21) et un deuxième côté adjacent au logement de chambre à vide (200), les cellules à graines (54) comprenant des ouvertures à travers le disque et espacées radialement à une certaine distance par rapport à un axe de l'élément substantiellement circulaire ; et ledit premier côté de l'élément circulaire comprenant la pluralité de canaux (91) agencés en un groupe radial autour de l'axe de l'élément substantiellement circulaire de telle sorte qu'un canal respectif (91) soit situé substantiellement vers l'intérieur dans le plan radial et à l'avant d'une ouverture correspondante ; dans lequel les canaux (91) sont configurés de façon à déplacer des graines adjacentes à un canal et vers une ouverture pour les retenir jusqu'à leur libération à partir de celle-ci.
12. Disque à graines (22) pour une utilisation avec un doseur de graines pneumatique (20) d'un matériel agricole, comprenant :
une structure cylindrique ayant des premier et deuxième côtés et contenant une pluralité de cellules à graines (54) à travers ceux-ci, lesdites cellules à graines (54) étant agencées en un groupe radial à une certaine distance par rapport à un axe de la structure cylindrique ;
une pluralité de canaux (91) agencés en un groupe radial et positionnés autour de l'axe de la structure cylindrique sur le premier côté de la structure de telle sorte qu'un canal respectif (91) soit situé substantiellement vers l'intérieur dans le plan radial et à l'avant d'une cellule à graines correspondante (54) ; et une ouverture cylindrique centrale (56) dans celle-ci pour un montage sur ledit doseur à graines (20), **caractérisé en ce que** les cellules à graines (54) et les canaux (91) sont positionnés au niveau d'une partie en bride (51) incluant une partie s'étendant à partir d'une face du disque à graines (22) et incluant une lèvre interne et un chanfrein externe.
13. Disque à graines de la revendication 12 comprenant en outre un pignon annulaire dirigé vers l'intérieur positionné autour de l'ouverture cylindrique centrale (56).

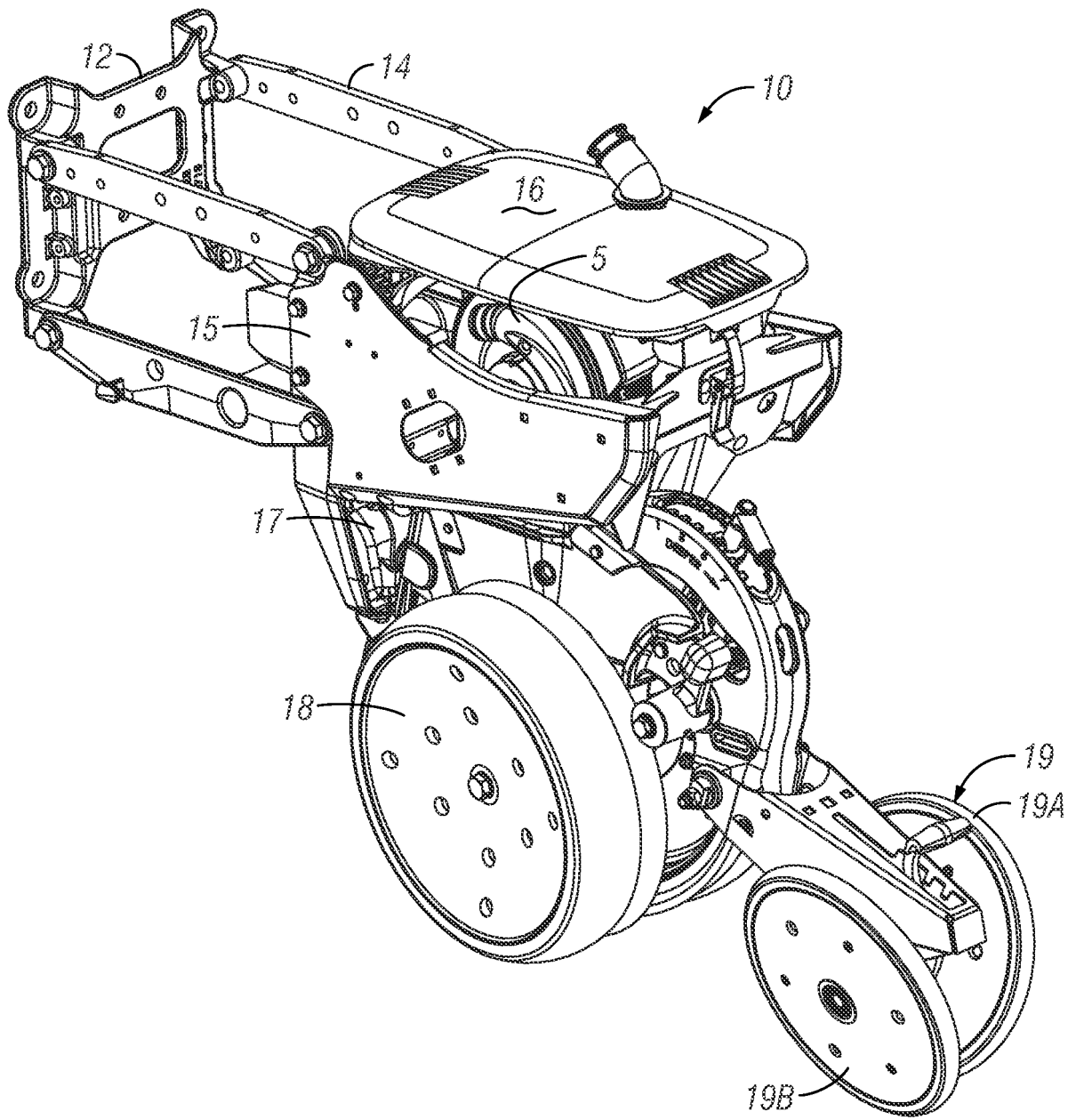

FIG. 1

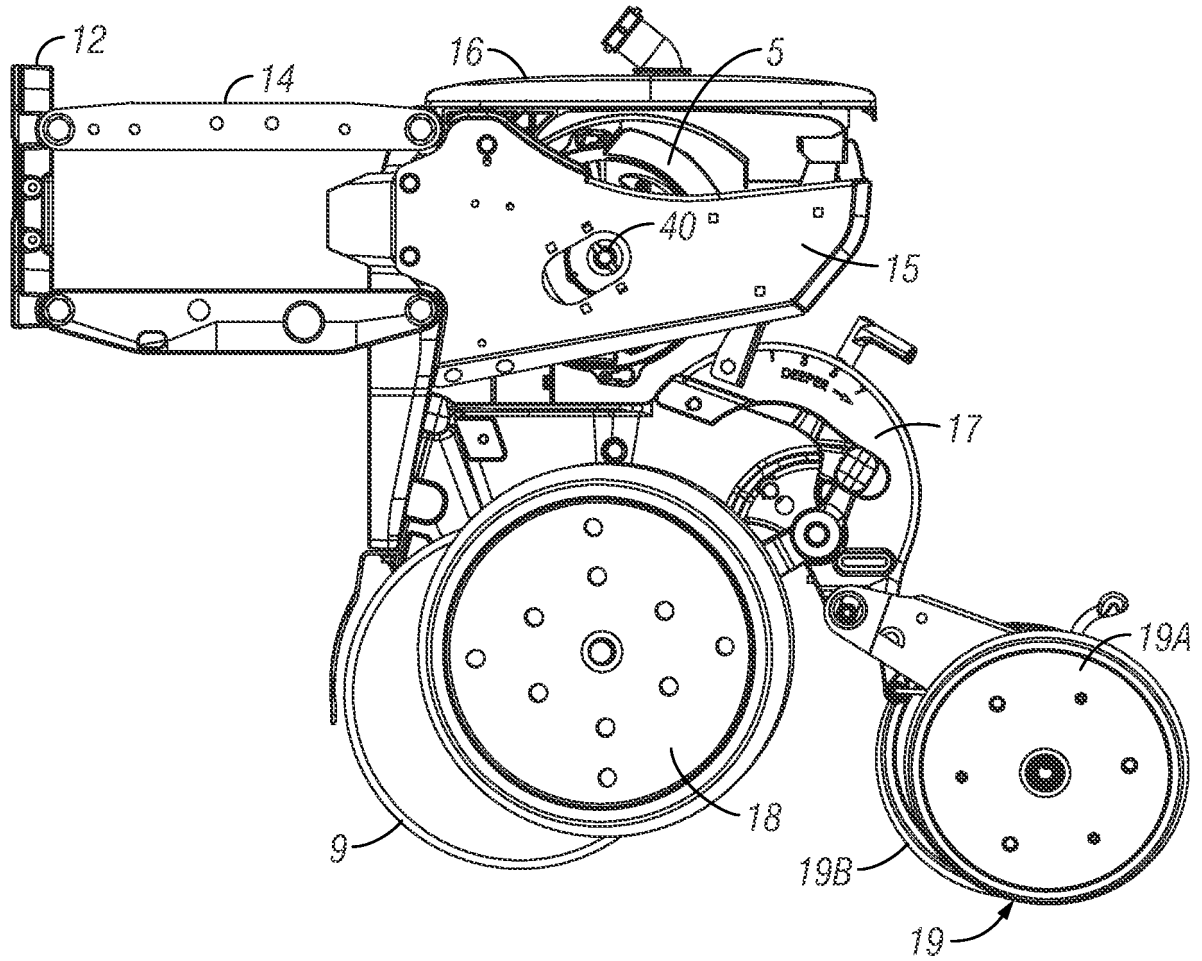

FIG. 2

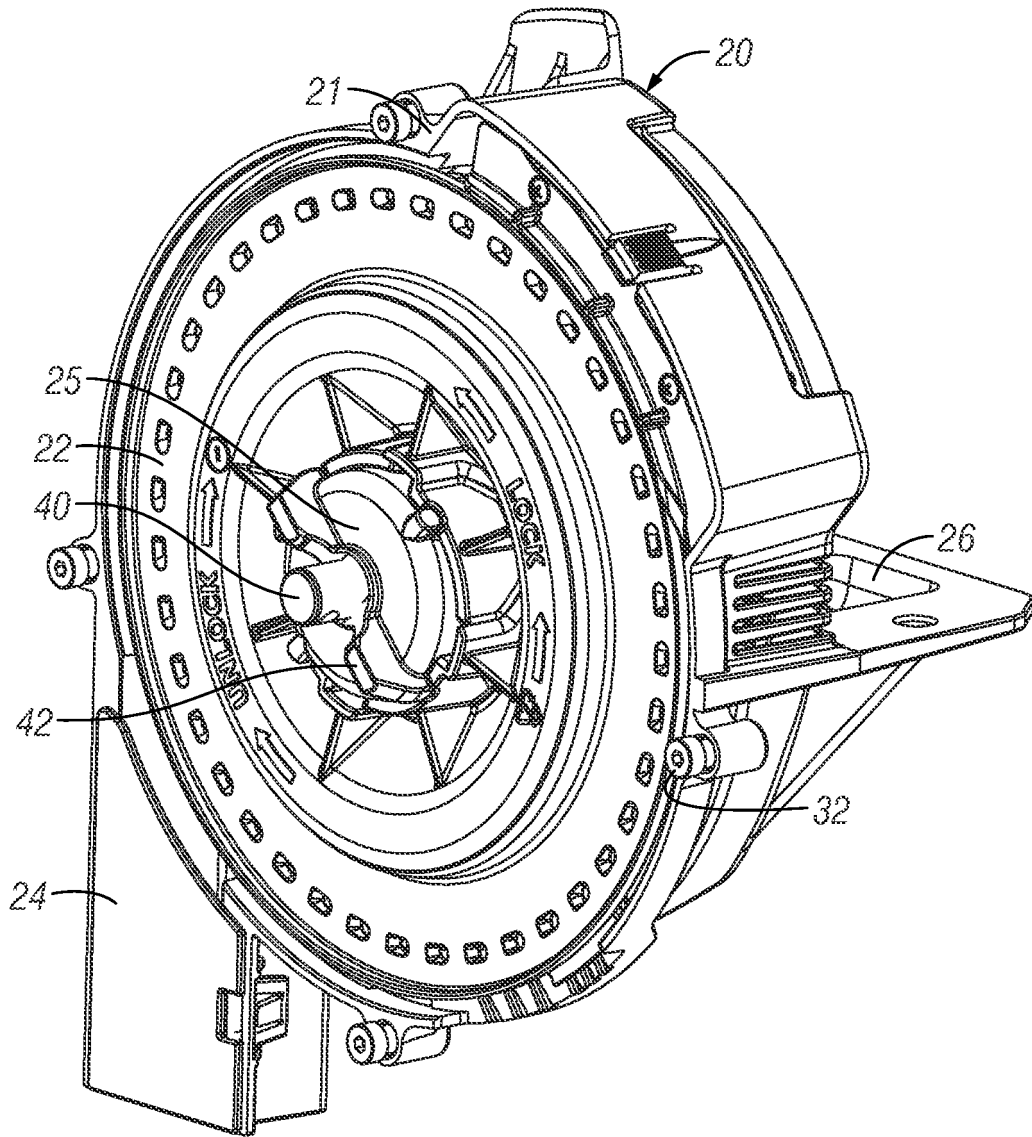

FIG. 3

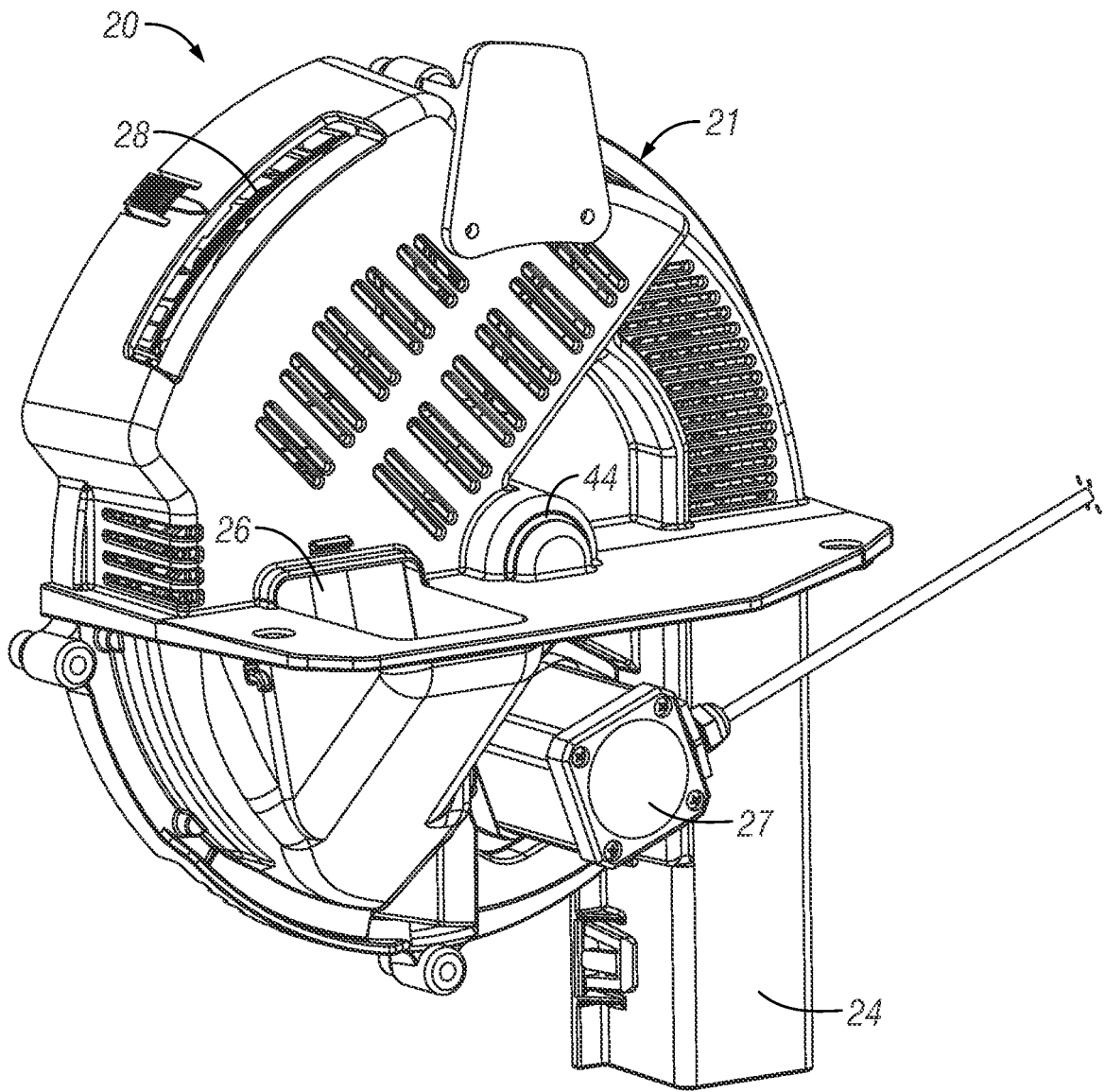

FIG. 4

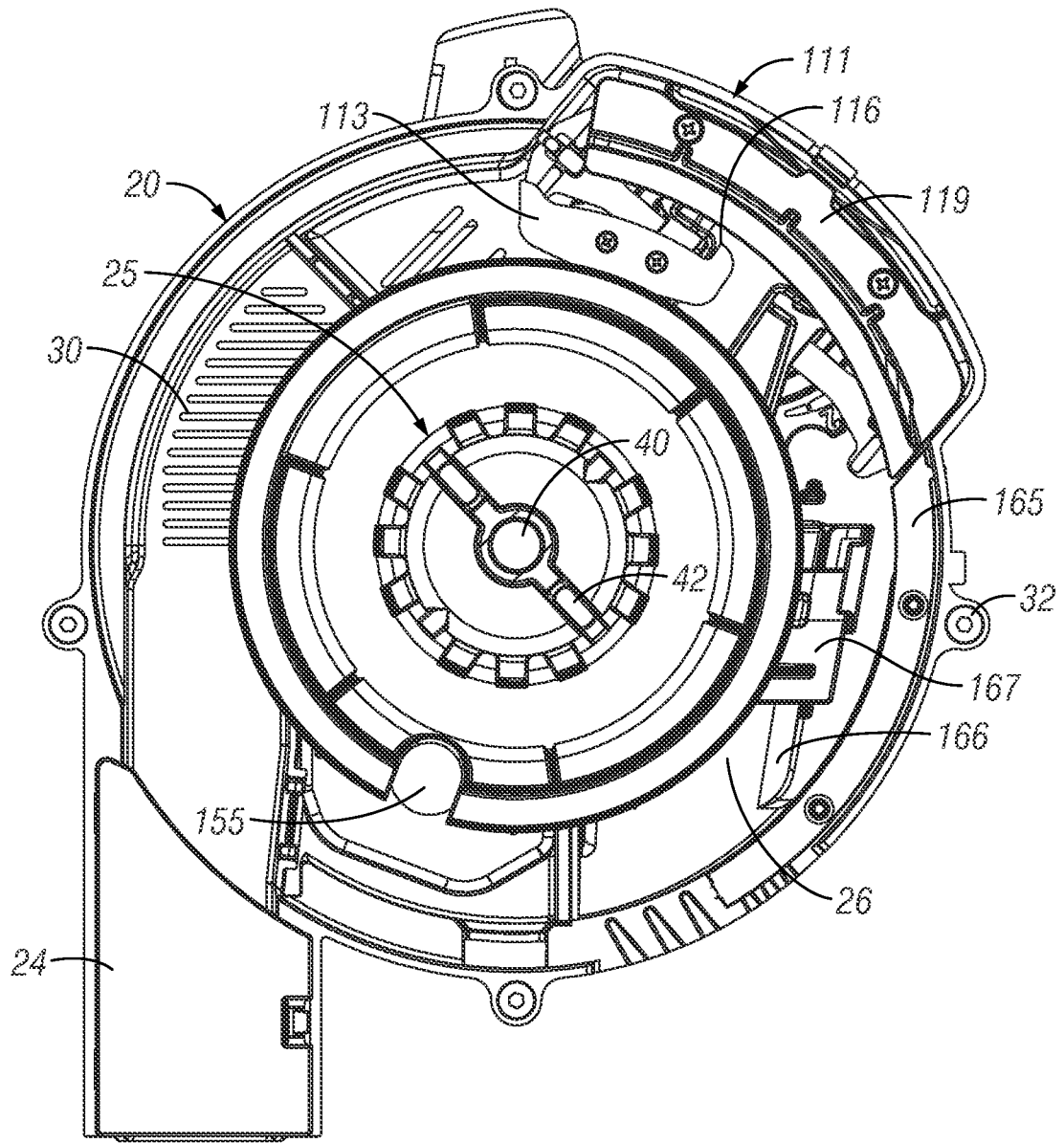

FIG. 5

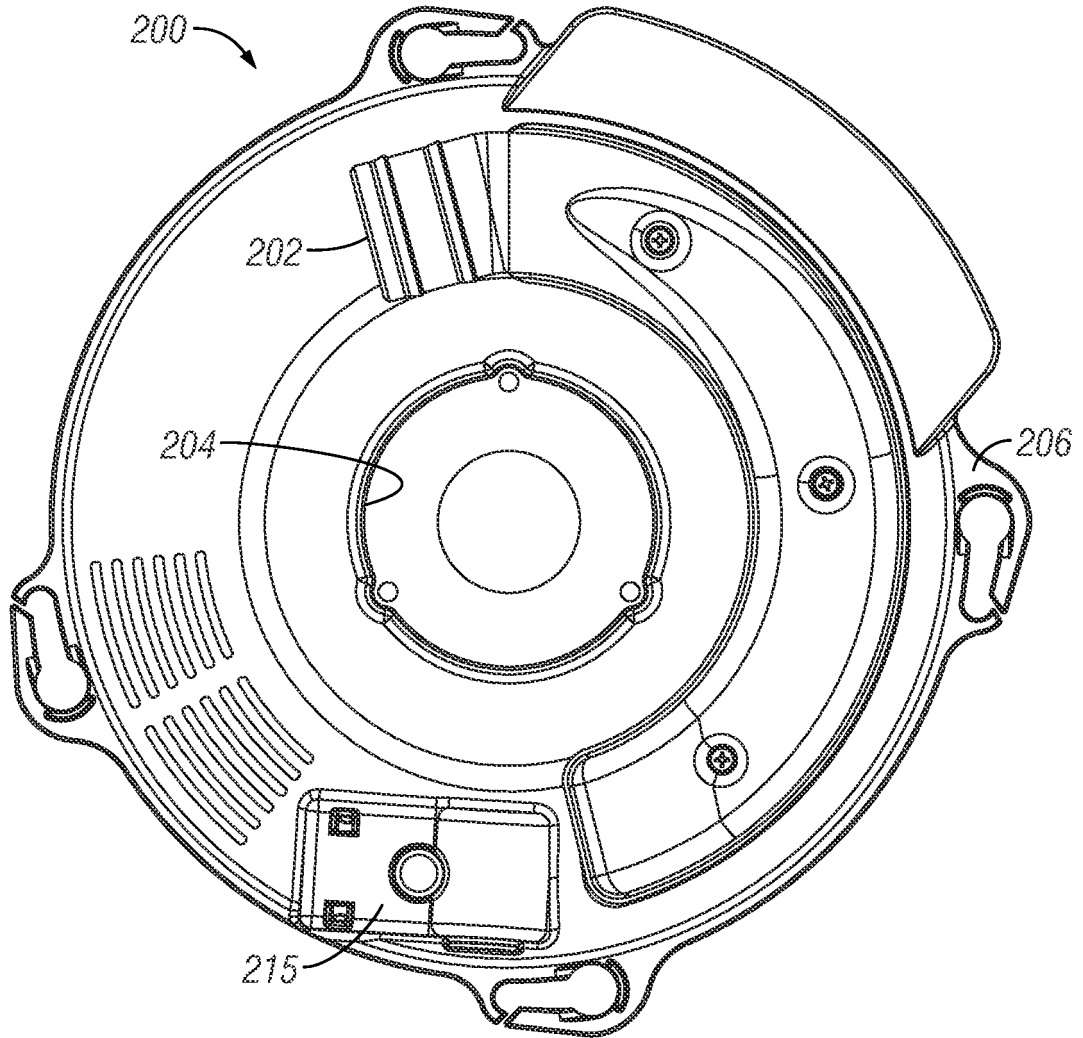

FIG. 6

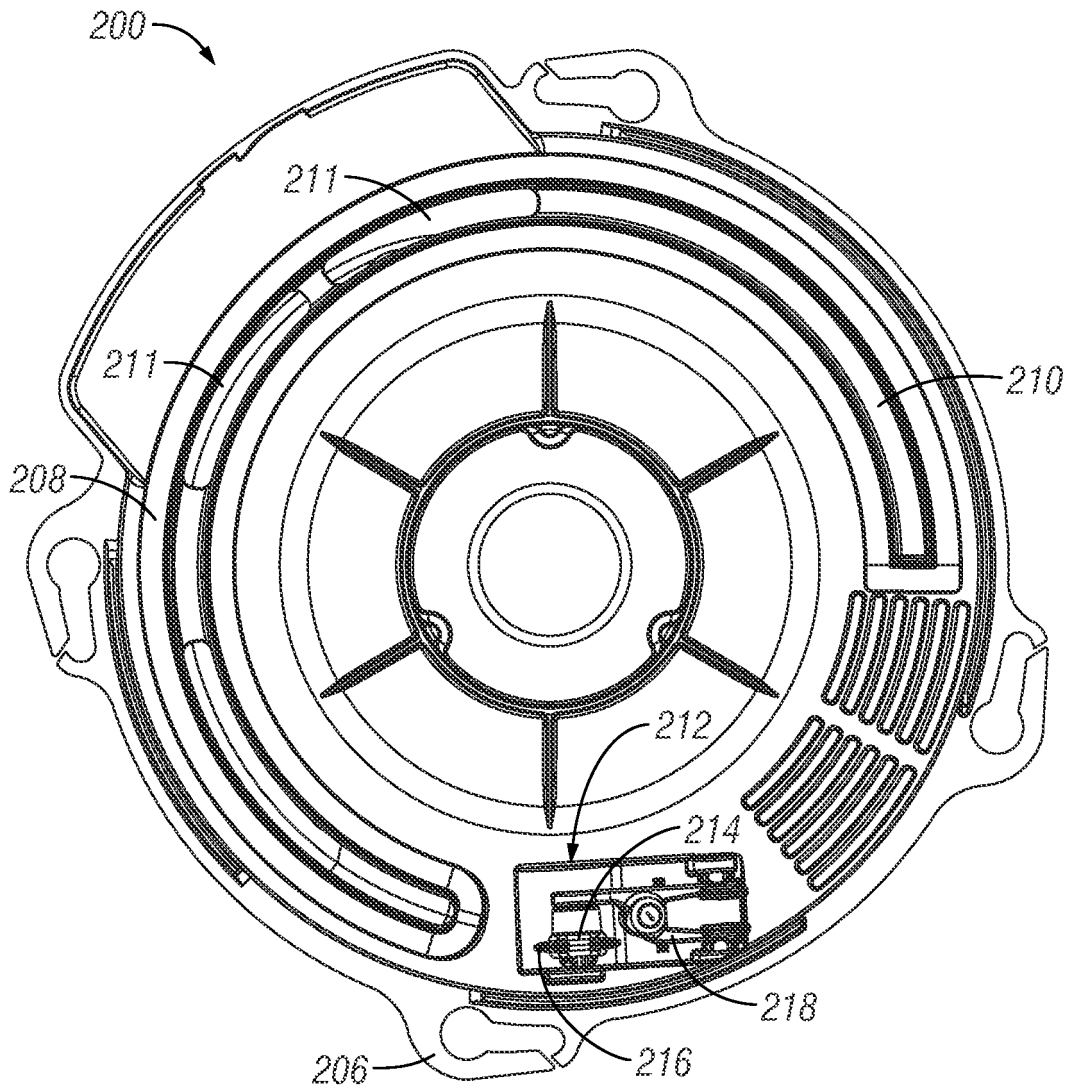
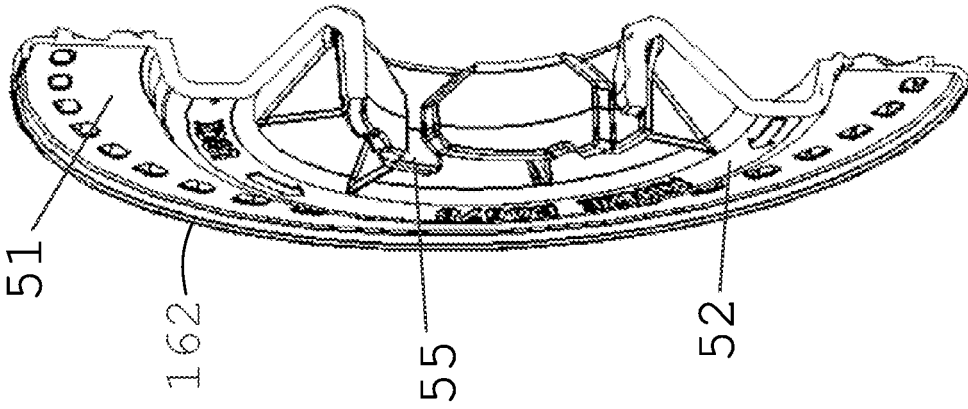
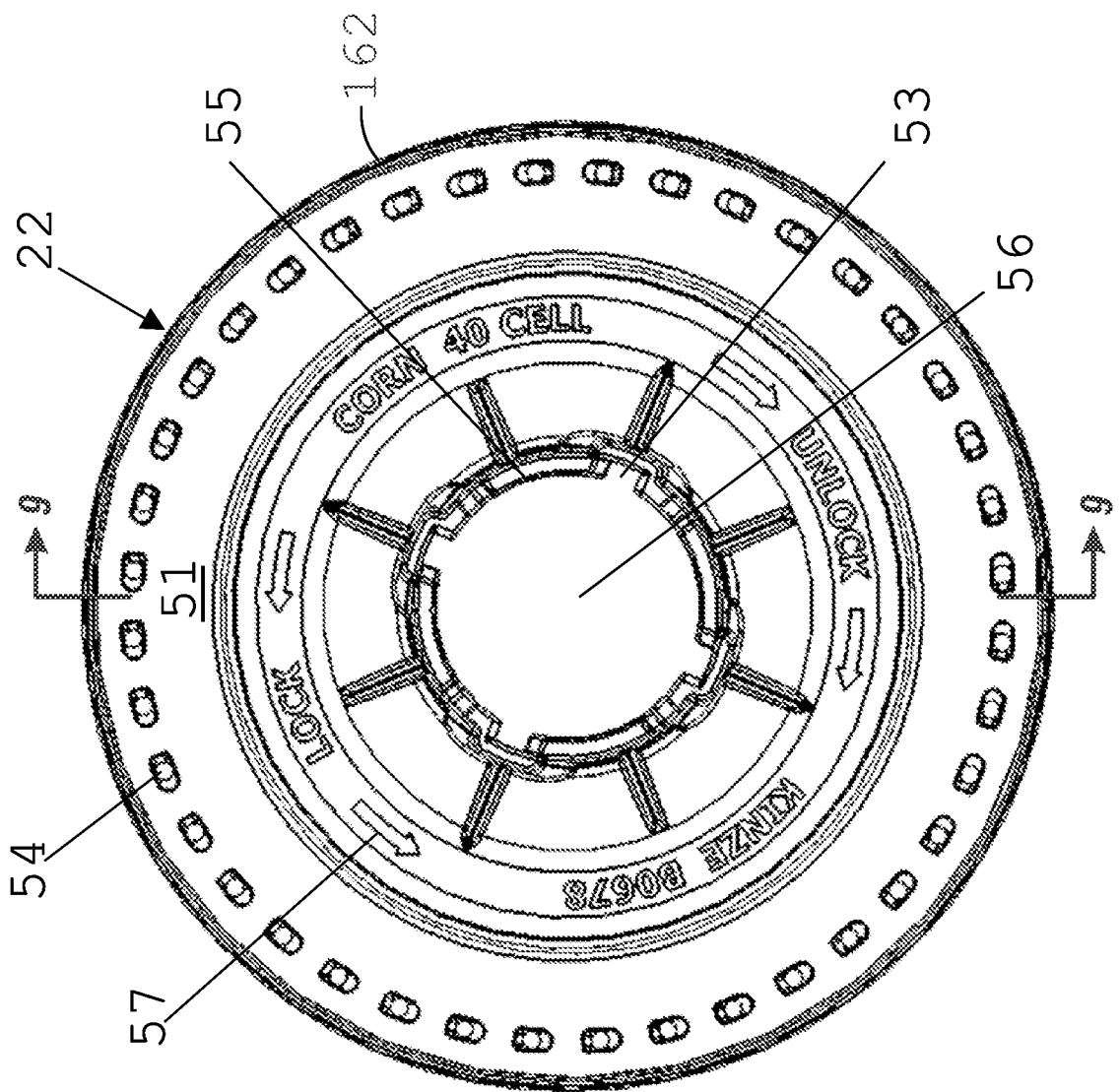

FIG. 7



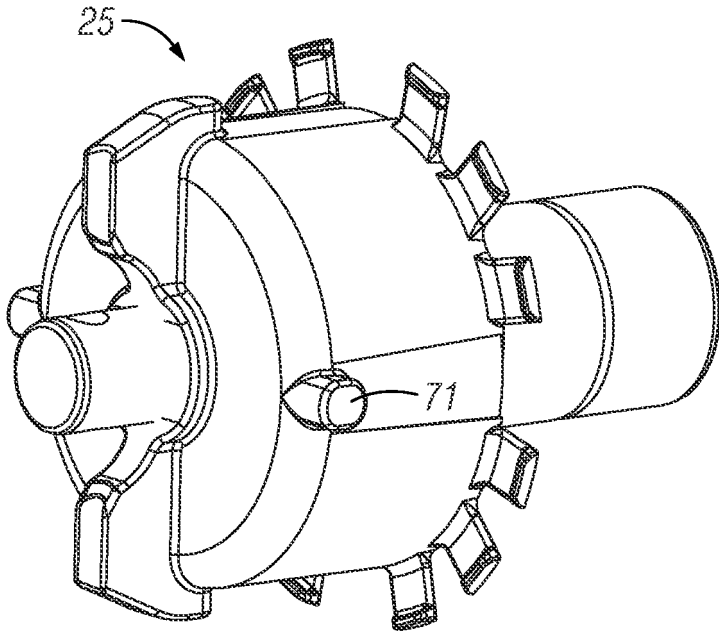

FIG. 10

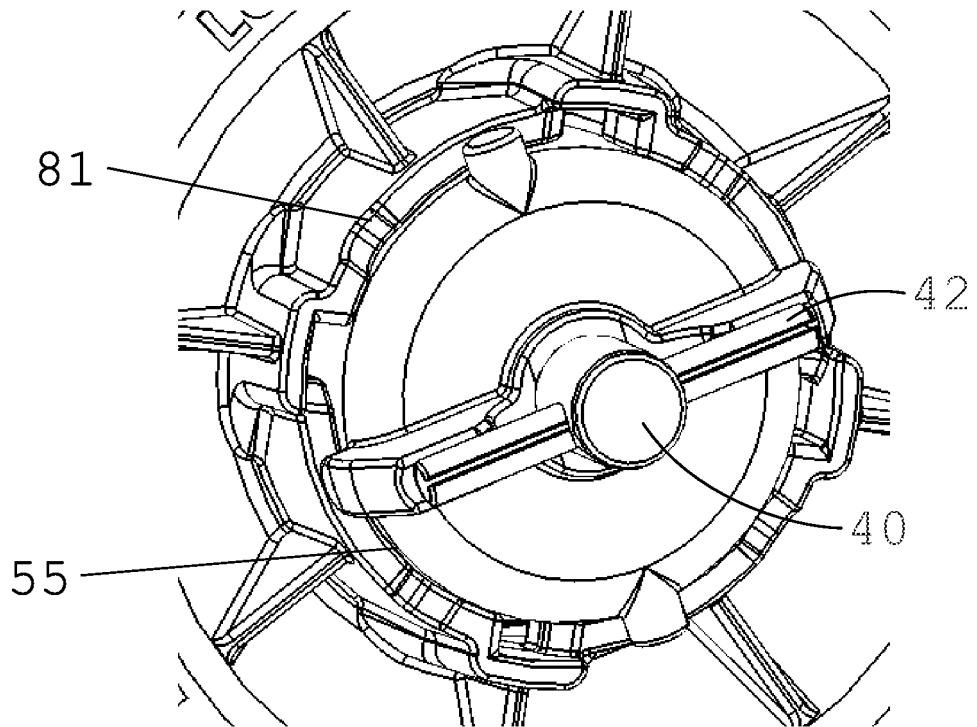

FIG. 11

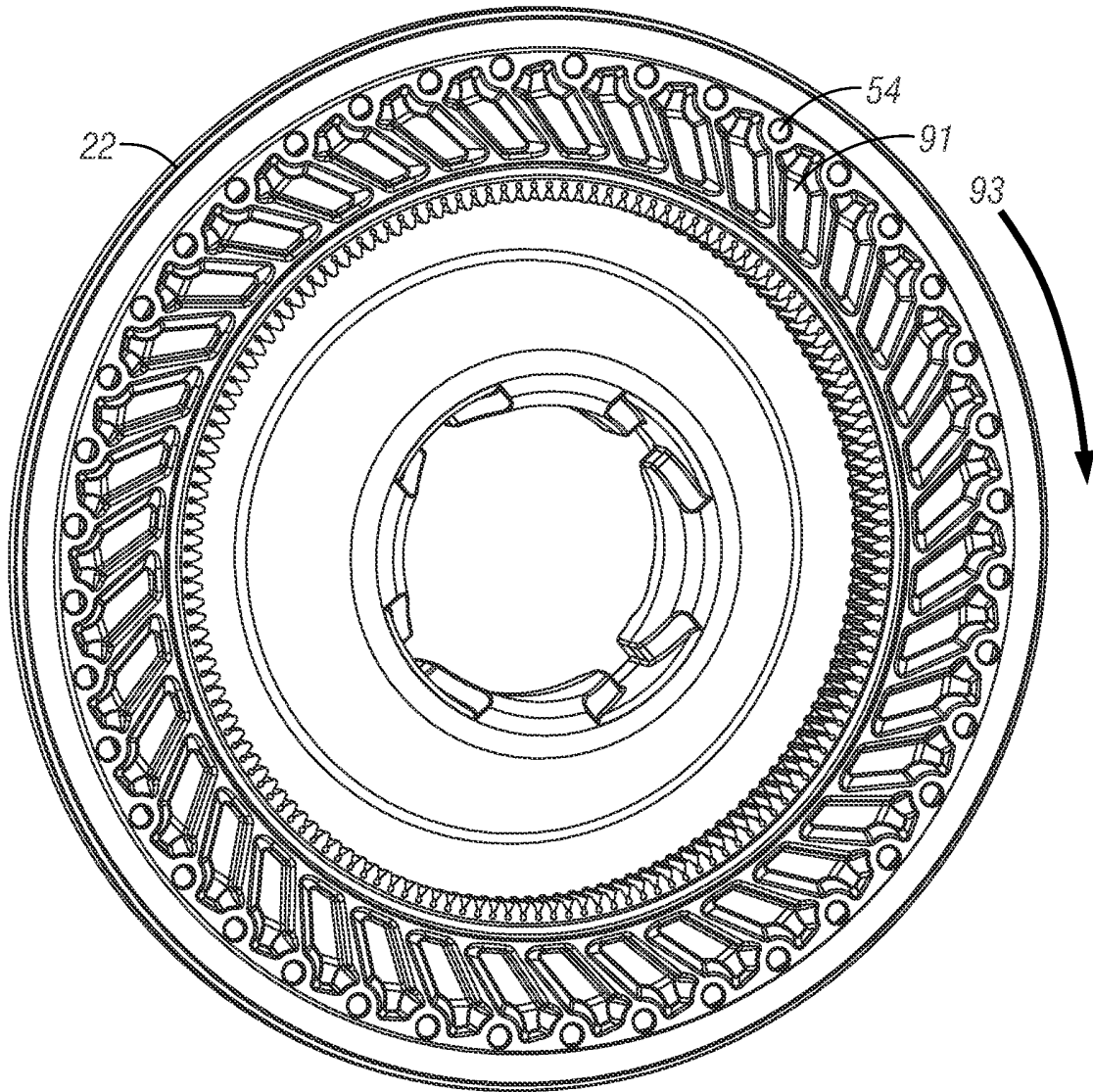

FIG. 12

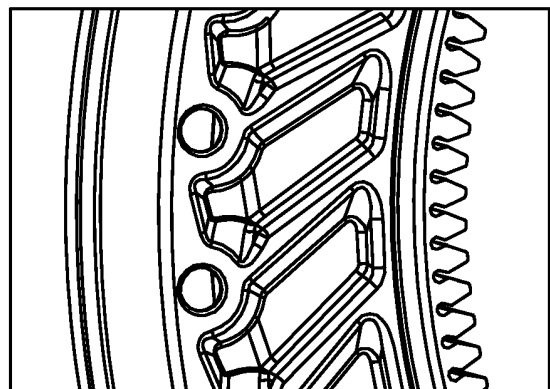

FIG. 13

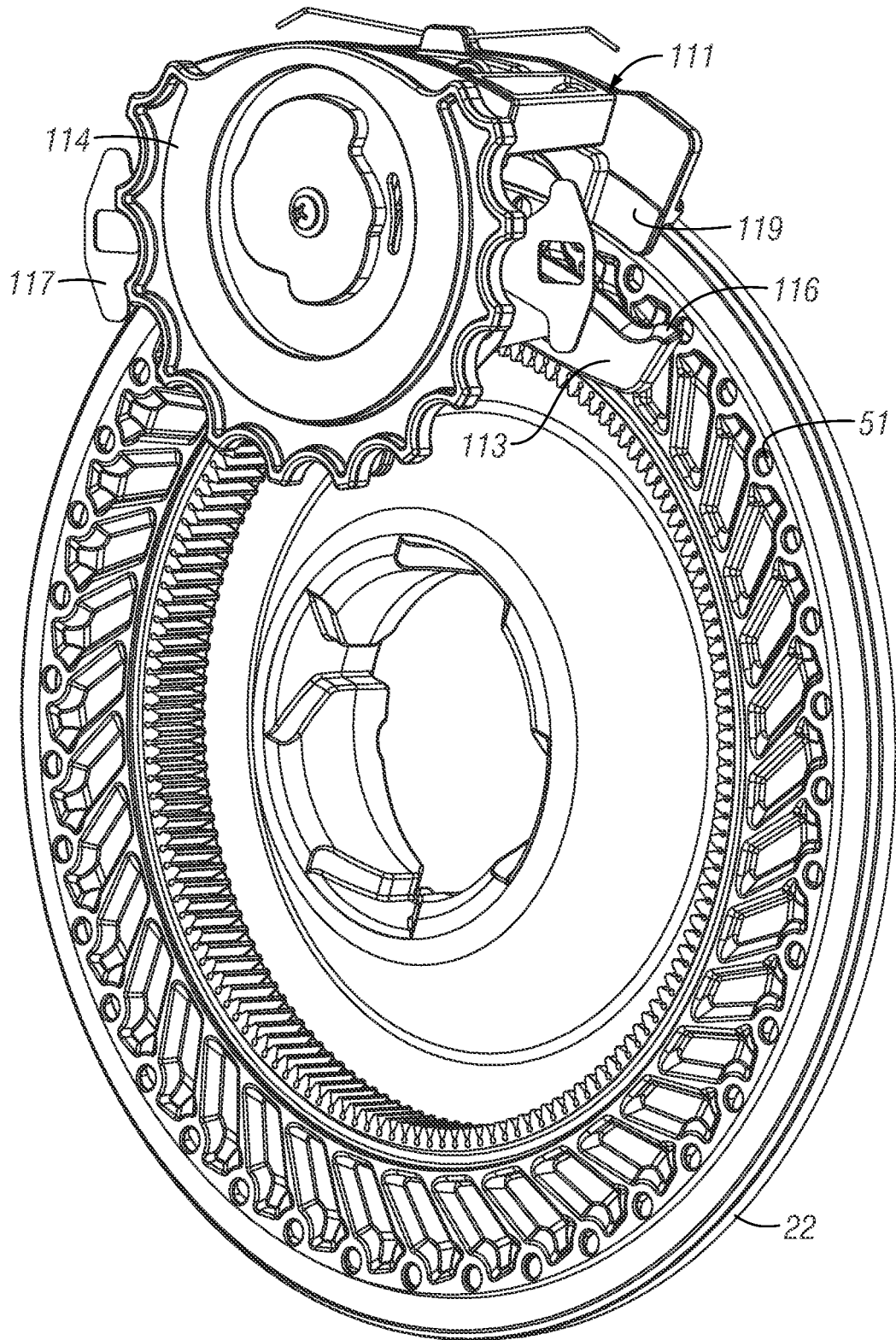

FIG. 14

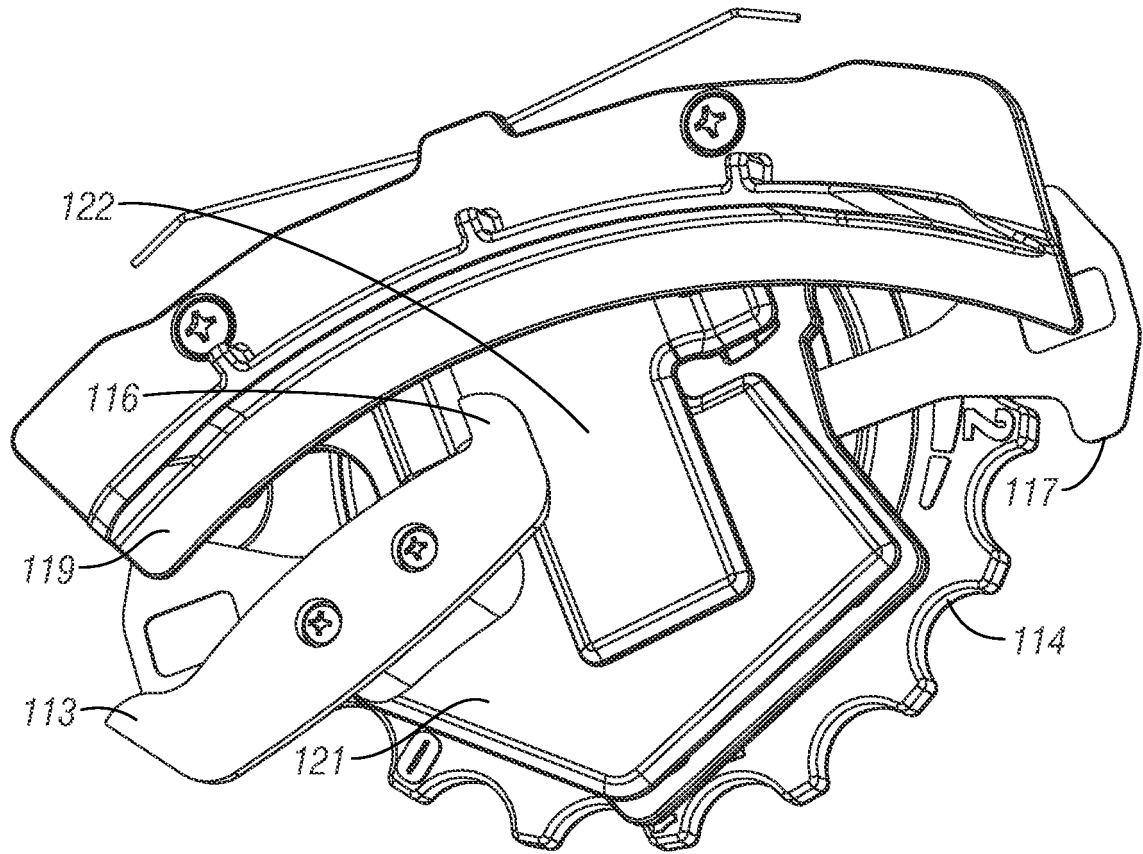

FIG. 15

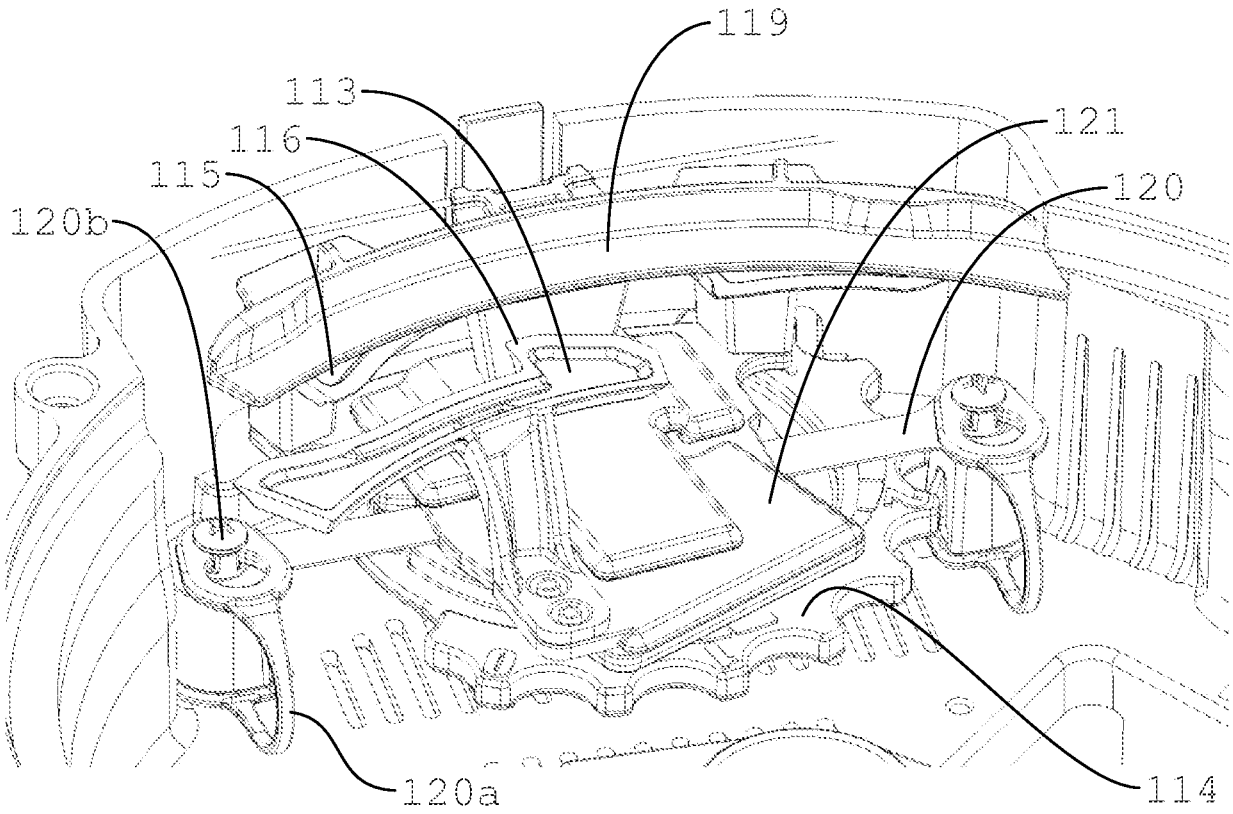

FIG. 15A

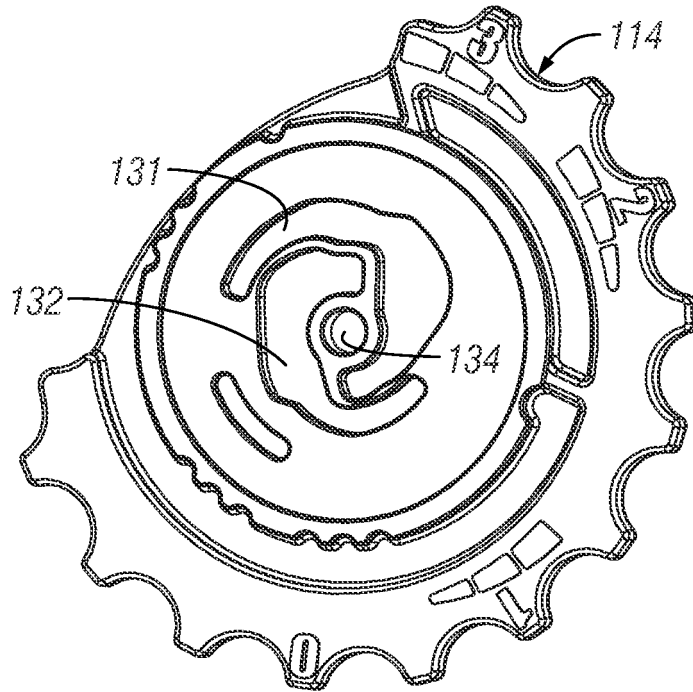

FIG. 16

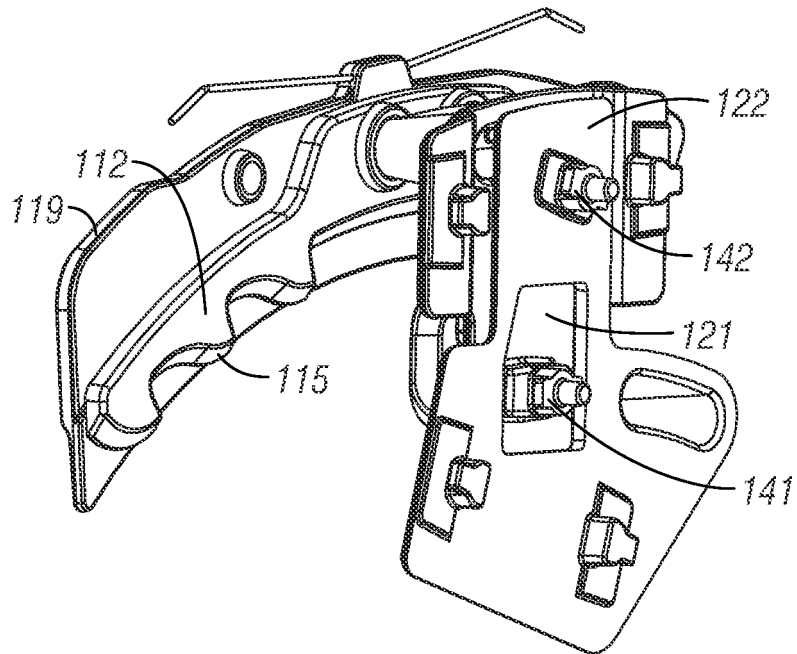

FIG. 17

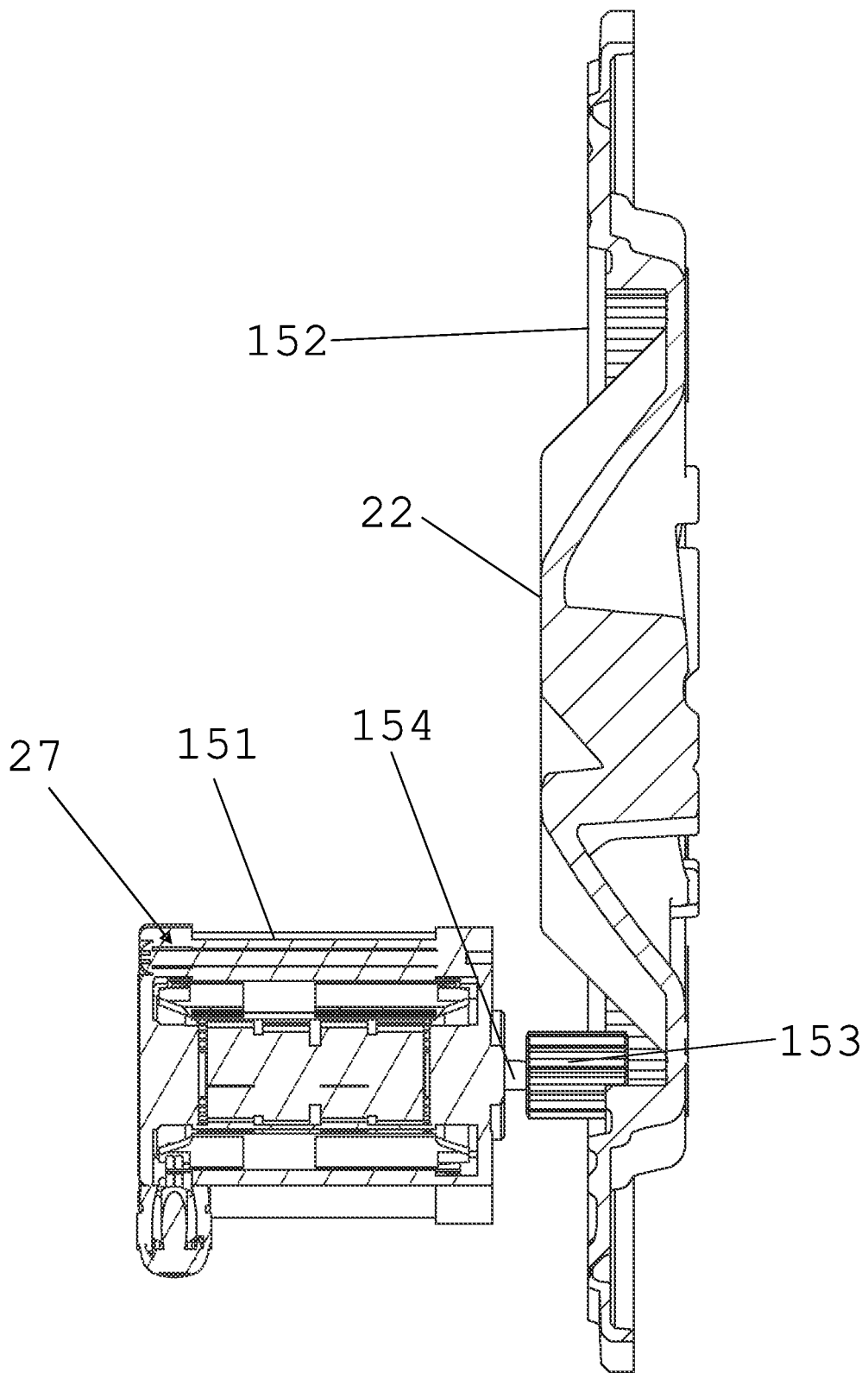

FIG. 18

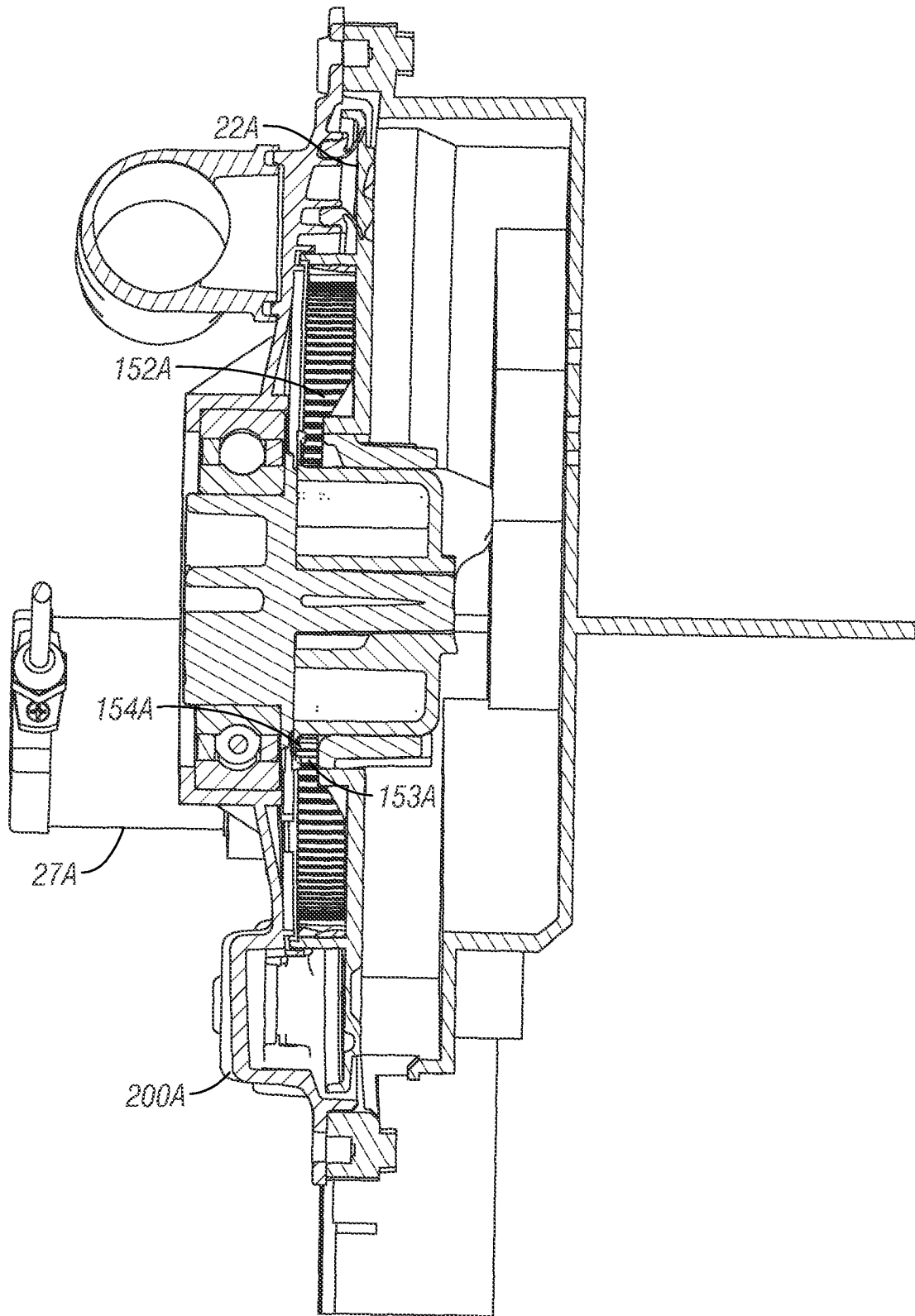

FIG. 19

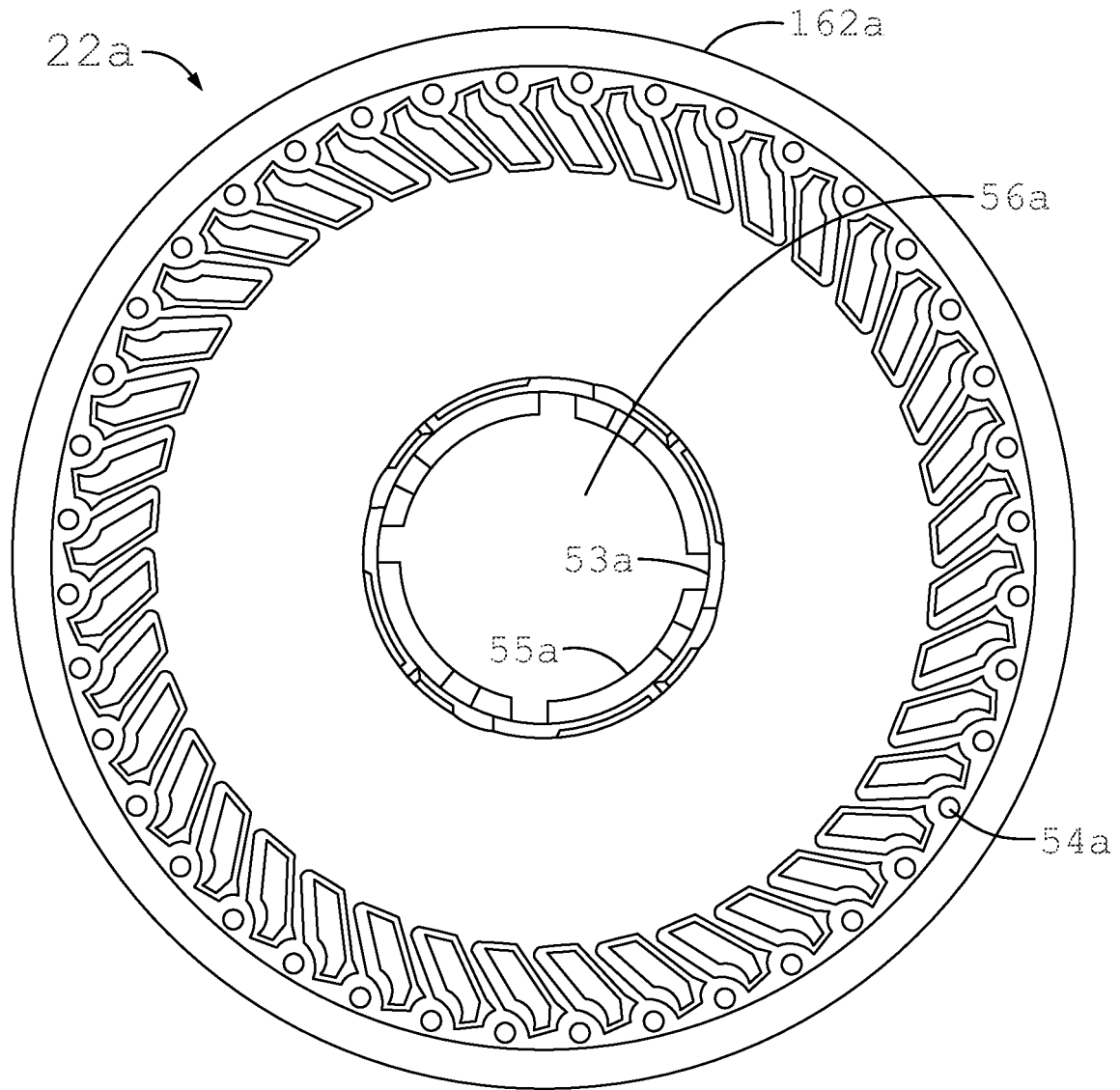

FIG. 20

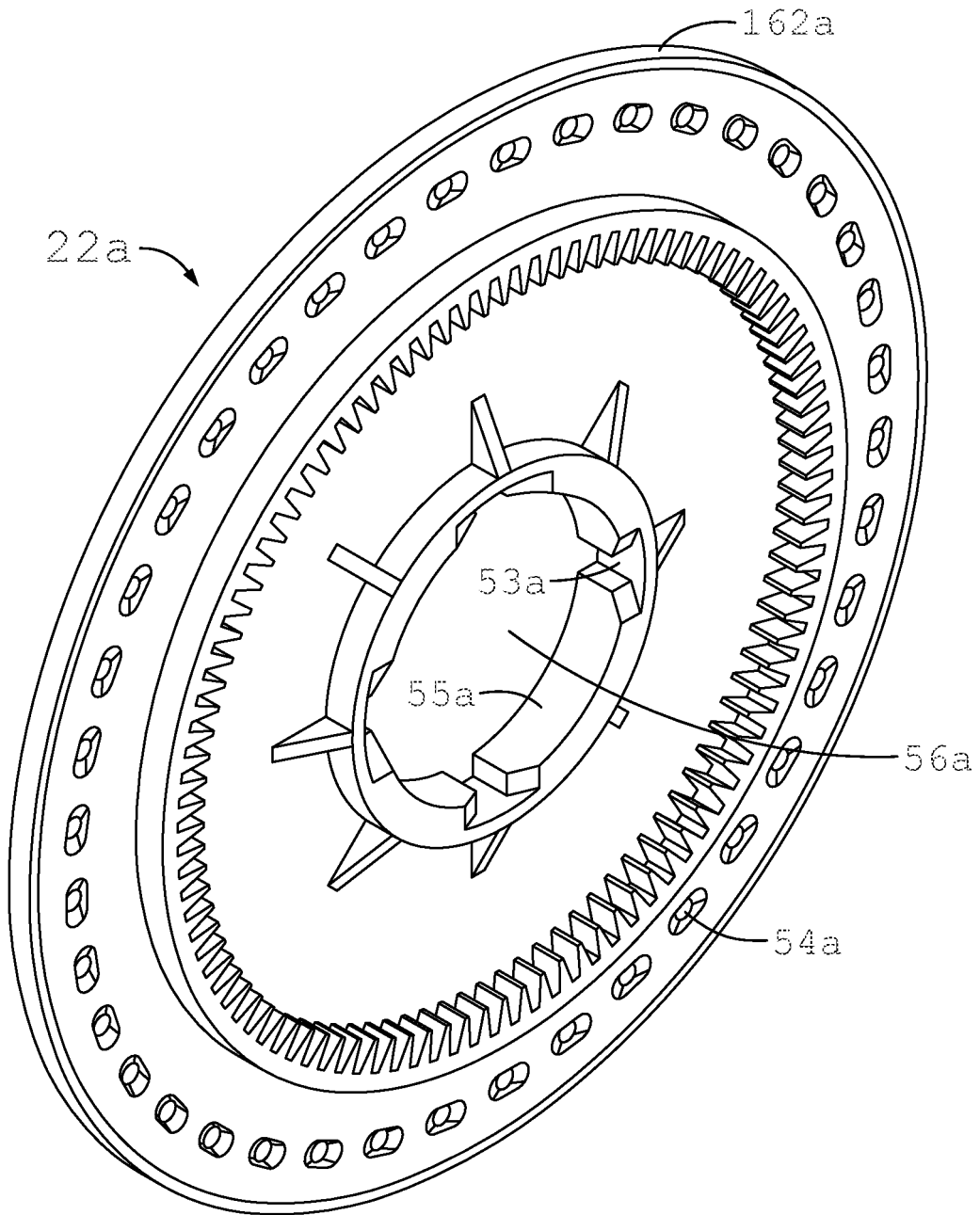

FIG. 21

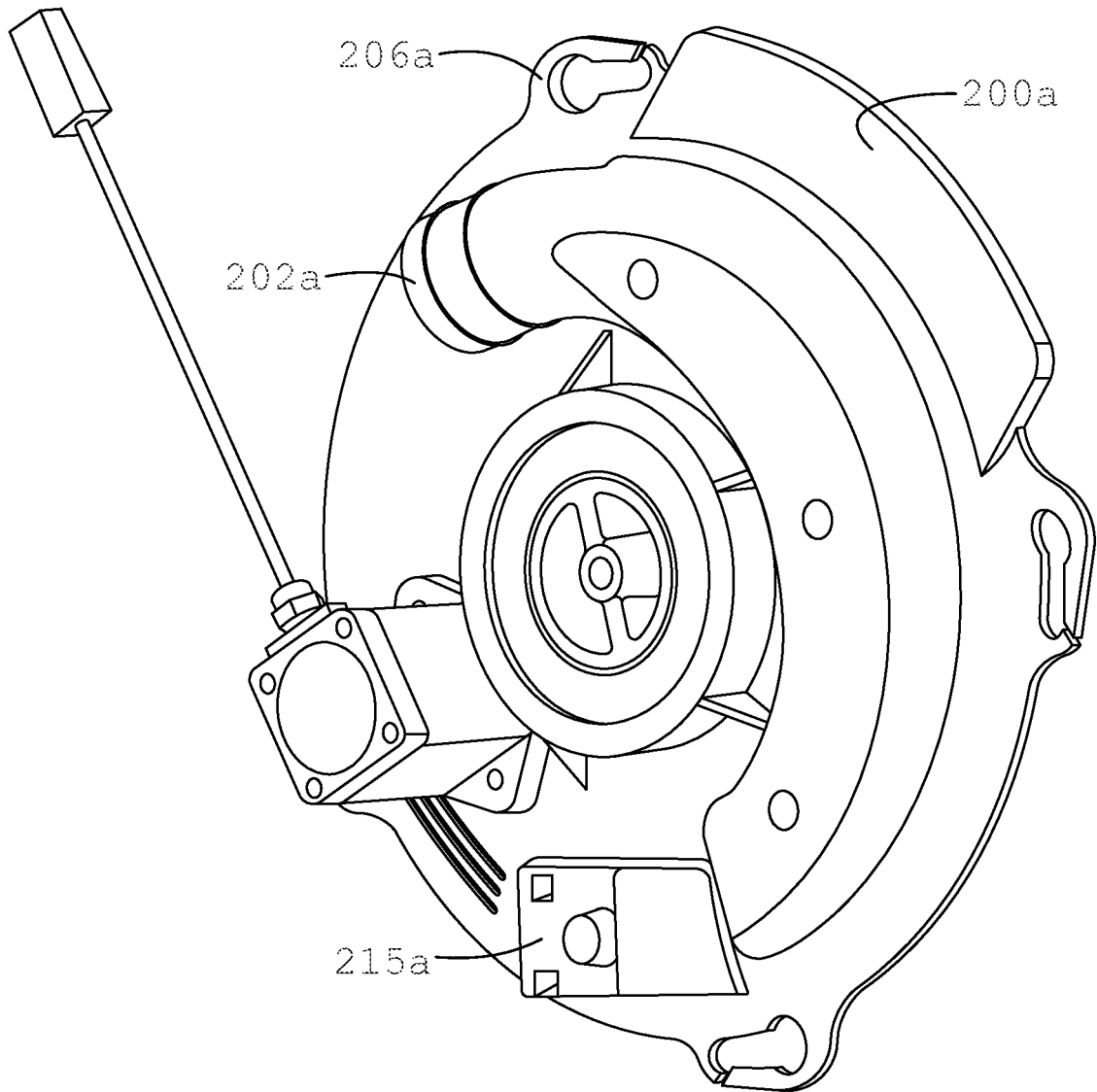

FIG. 22

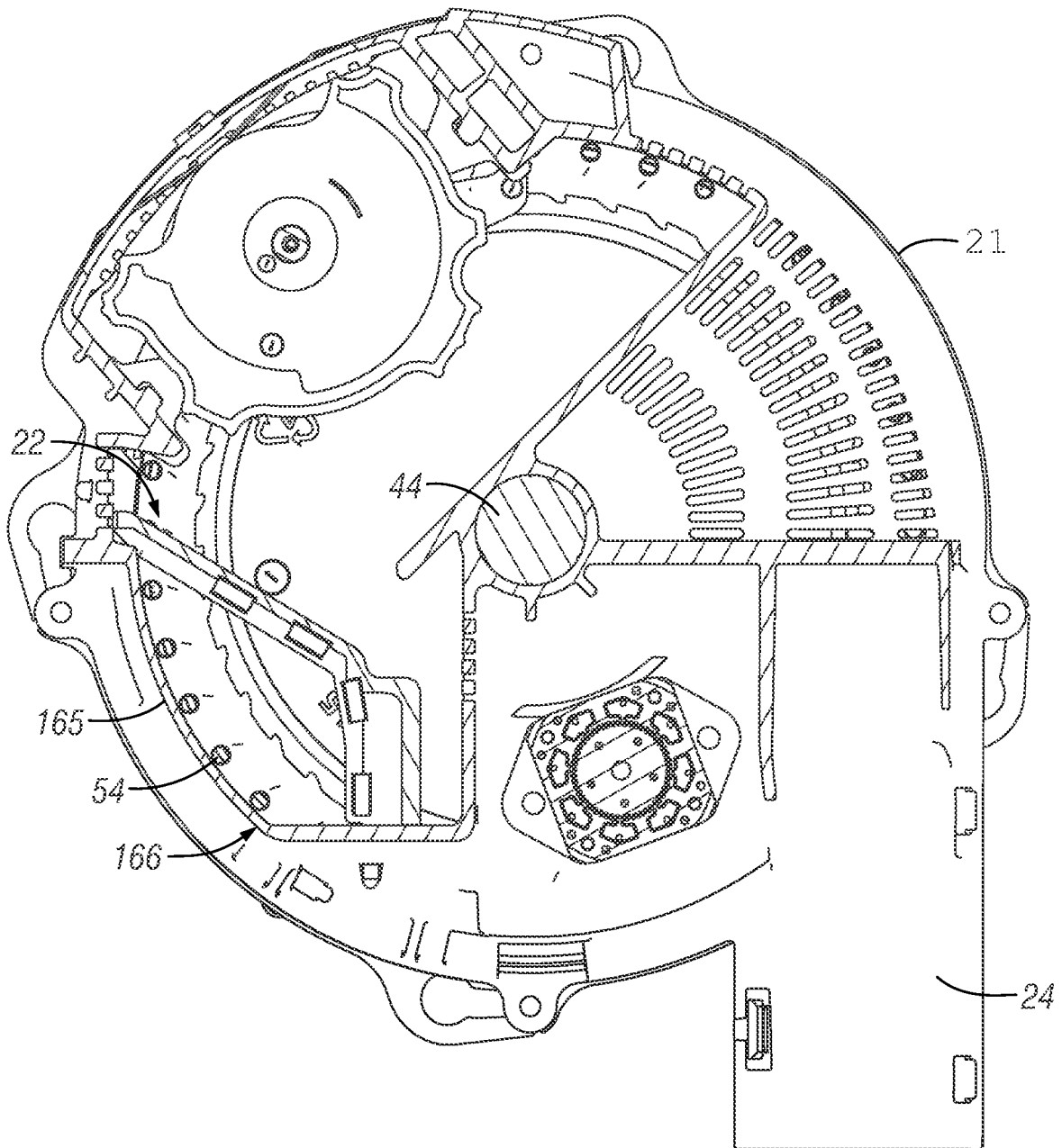

FIG. 23B

REFERENCES CITED IN THE DESCRIPTION

This list of references cited by the applicant is for the reader's convenience only. It does not form part of the European patent document. Even though great care has been taken in compiling the references, errors or omissions cannot be excluded and the EPO disclaims all liability in this regard.

Patent documents cited in the description

- US 5058766 A [0011]
- US 4450959 A [0044]