



Operator's Manual  
Firmware Version 9.0  
PN 2006395—ENG Rev. V

© 2023 Ag Leader Technology  
2202 South Riverside Drive  
Ames, Iowa 50010 USA

---

## General Information

End-User Licence Agreement (EULA) .....	1
Service and Support .....	1
Color Touch-Screen .....	1
Technical Specifications .....	2
System and Upgrades .....	2
Automated Module Firmware Upgrade .....	2
Product Registration .....	3
<b>Operator Safety .....</b>	<b>3</b>
Symbols .....	3
Precautions .....	3
General info .....	3
Service .....	3
<b>Display .....</b>	<b>4</b>
Display Hardware .....	4
Front side .....	4
Side .....	4
Rear .....	5
Installation Instructions .....	5
Fuse Installation and Replacement .....	7

## Startup

<b>Initial Startup .....</b>	<b>9</b>
General info .....	9
Initial Setup Wizard .....	9
<b>Homescreen Layout .....</b>	<b>10</b>
<b>Status Indicators .....</b>	<b>11</b>
<b>AgFiniti Status Indicators .....</b>	<b>11</b>
Diagnostics .....	12
Diagnostics .....	13
CAN B .....	13
Alerts .....	14
InCommand 800 Guidance Only details .....	14
Upgrading Display Firmware .....	14
Automatic Firmware Updates .....	15
Manual Updates .....	16

## Configurations

<b>Equipment Setup .....</b>	<b>19</b>
Configuration tab .....	19
Vehicle Offsets .....	20
Hitch Settings tab .....	22
Mount Tab Settings .....	22
Implement Offsets .....	22
Section Offsets .....	23
Speed Input Settings .....	23
Product tab .....	24
Add button .....	25
<b>Management Setup .....</b>	<b>25</b>
<b>Management button</b> —from this screen the operator can access Grower/Farm/Field, Season, User, and Businesses tabs.Grower/Farm/Field tab .....	25
Grower .....	26
Farm and Field .....	26
Season tab .....	28

---

Users tab .....	28
Add a User .....	29
Edit User Profile .....	29
Permissions tab .....	31
Permission Level For Operators .....	31
Accessing Setup Menus .....	34
Accessing Data Transfer .....	34
Forgotten Passwords .....	35
Businesses tab .....	36
<b>Display Setup .....</b>	<b>37</b>
Features tab .....	37
Advanced tab .....	38
General Tab .....	39
Demo Mode .....	40
ISOBUS Settings .....	41
Universal Terminal .....	42
Task Controller .....	42
ISO Load and Go .....	42
File Server .....	42
Common Terminology .....	42
Auxiliary Assignment .....	46
UT Alarms and Trouble Codes .....	47
<b>Video .....</b>	<b>48</b>
<b>Data Management</b>	
<b>Data Transfer screen .....</b>	<b>51</b>
<b>.AGSETUP Files .....</b>	<b>52</b>
Import .AGSETUP file from AgFiniti® or USB .....	52
Export .AGSETUP file to AgFiniti or USB .....	52
<b>.AGDATA files .....</b>	<b>53</b>
<b>Exporting Logged Data .....</b>	<b>53</b>
Export .AGDATA file .....	53
ISO XML export .....	53
Supported operations .....	54
Enable ISO XML Export .....	54
Display Backups .....	54
ibk3 files .....	54
<b>Create Backup File (USB drive Only) .....</b>	<b>54</b>
<b>Restore Backup File .....</b>	<b>55</b>
<b>Upgrade Firmware.fw3 .....</b>	<b>55</b>
<b>Export Reports .....</b>	<b>55</b>
<b>Manual Sync .....</b>	<b>55</b>
<b>AgFiniti</b>	
<b>AgFiniti® .....</b>	<b>57</b>
<b>AgFiniti Mobile .....</b>	<b>57</b>
AgFiniti Cloud .....	57
AgFiniti Essentials .....	58
<b>AgFiniti Mobile Connection Types .....</b>	<b>59</b>
Display Access Point Mode .....	59
Wi-Fi Network .....	59
Cellular iPad as Personal Hotspot .....	59
<b>Display Access Point Connection Type .....</b>	<b>59</b>
<b>InCommand Display .....</b>	<b>60</b>
<b>iPad .....</b>	<b>60</b>

---

<b>AgFiniti Mobile</b> .....	<b>62</b>
Map Screen .....	62
Gestures .....	63
Filters .....	64
Stat Cards .....	65
Labels .....	67
Area Query .....	68
Zoom Options .....	68
Add Note .....	69
Print .....	70
Summary Reports .....	71
Menu button .....	71
Manage Data .....	73
<b>AgFiniti Essentials - Cloud Sync</b> .....	<b>73</b>
Sync Settings .....	74
Display and Device Location .....	76
Live Stats - Mobile .....	76
Live Maps – Mobile .....	77
AgFiniti Display Settings .....	78
Logging into an AgFiniti Account .....	78
Logout and De-register Display .....	78
Mobile Management .....	79
<b>File Transfer</b> .....	<b>79</b>
<b>Remote Support</b> .....	<b>79</b>
Remote Support Pre-authorization .....	80
Remote Support Permissions Options .....	80
<b>Cellular iPad as Personal Hotspot Connection</b> .....	<b>81</b>
<b>Shared Wi-Fi Network Connection</b> .....	<b>83</b>
InCommand Display .....	86

## DisplayCast

<b>DisplayCast®</b> .....	<b>87</b>
How it works .....	87
Use cases .....	87
Information that is synced .....	87
Requirements list .....	88
First time setup and sync .....	88
Data syncing intervals .....	89
Getting started .....	89
Sync options .....	90
DisplayCast Error Messages .....	91
DisplayCast Season Management .....	91
<b>Network Diagnostics</b> .....	<b>92</b>
<b>DisplayCast Statistics</b> .....	<b>92</b>
Starting an event for multiple displays in the same field and operation .....	94
Live Stats—DisplayCast .....	95
Loading a Guidance Pattern while using DisplayCast .....	96
Viewing active and past events for the field currently loaded on the Mapping screen .....	96
Using Summary Report page to view any active or past events .....	97
Harvest Variety Tracking with DisplayCast .....	98
Data management with DisplayCast .....	98
Configurations .....	98
Logged data (agdata) .....	98
Changes and updates to management Items .....	99

---

## Field Operations

<b>Events</b> .....	<b>101</b>
<b>Field Operations</b> .....	<b>101</b>
<b>Heading Detection</b> .....	<b>103</b>
Heading Change Button .....	103
Disable/Enable Heading Detection .....	103
<b>Vehicle Icon</b> .....	<b>104</b>
Master Switch Status .....	104
(O) AutoSwath button—turns the AutoSwath feature on and off. ....	105
(P) Logging button .....	105
AutoSteer button .....	105
Map Legend tab .....	105
<b>Map Toolbox</b> .....	<b>105</b>
Legend Settings .....	105
Map Options .....	107
Map Shift .....	108
Map Shift General Guideline .....	108
Enable Map Shift .....	108
Shifting the Map .....	108
Mapping Features .....	111
Map Views and Split Screen .....	112
Map Views .....	113
Setting the Follow View mode .....	113
Zoom Devices View .....	113
Zoom Devices in AgFiniti Mobile .....	114
Universal Terminal Split Screen .....	114
Split Screen Advanced Seed Monitoring .....	115
Split Screen Video .....	115
<b>(A)</b> With Cameras attached, pressing the video button with split the screen between the active map and the video page. ....	115
<b>(B)</b> Mirror Video Input .....	115
<b>(C)</b> Brightness Adjust .....	116
<b>(D)</b> Contrast Adjust .....	116
<b>(E)</b> Full Screen/Split Screen selection .....	116
Markers Tab .....	116
<b>Operator Selection</b> .....	<b>117</b>
Operator Log Out .....	117
<b>Menu Buttons</b> .....	<b>117</b>
Event .....	119

## In-Field Functions

<b>Automatic Swath Control</b> .....	<b>121</b>
Boundary Tab .....	122
<b>Create Boundary</b> .....	<b>123</b>
Boundary Settings .....	123
<b>Headlands</b> .....	<b>125</b>
Active Area .....	126
Add a Headland .....	126
Headland Types .....	127
Load Headlands .....	128
Edit Headlands .....	129
Headland Alarm Settings .....	129
<b>Topography</b> .....	<b>129</b>
Topography Screen .....	130

Red, White, Blue Scheme .....	132
Brown-Tan Scheme .....	132
<b>Satellite Imagery .....</b>	<b>133</b>
Satellite Imagery Requirements .....	133
Enabling Satellite Imagery .....	133
Satellite Imagery on the Mapping Screen .....	134

## GPS/Steering Setup

<b>GPS Setup .....</b>	<b>135</b>
Steering .....	135
Lightbar Settings .....	136
GPS Button .....	136
Serial GPS Settings .....	137
WAAS/EGNOS Settings .....	138
<b>TerraStar Settings .....</b>	<b>139</b>
<b>RTK Settings .....</b>	<b>140</b>
RTK Settings - NTRIP External .....	140
RTK Settings - NTRIP RTK on InCommand .....	140
RTK Settings - NTRIP Relay (GPS 6500 Only) .....	142
RTK Settings - 400 MHz .....	145
RTK Settings - 900 MHz .....	145
<b>Upgrade Receiver .....</b>	<b>146</b>
<b>Serial Port Settings .....</b>	<b>147</b>
Port A tab .....	147
Port B tab .....	148
Port C tab .....	148
<b>GPS Information .....</b>	<b>149</b>
GPS Information - General Tab .....	149
GPS Messages .....	151
Satellite Plot .....	151
Satellite Plot - Graph .....	152
<b>GPS Information - Receiver Tab .....</b>	<b>153</b>
GPS Information - Differential Tab .....	153
Base Station .....	155
<b>RTK/NTRIP Information (ParaDyme/GeoSteer Only) .....</b>	<b>155</b>
<b>GPS Information - NTRIP .....</b>	<b>155</b>

## Guidance and Steering

<b>Guidance Tab on Mapping screen .....</b>	<b>157</b>
<b>New Pattern—Straight .....</b>	<b>157</b>
Select Pattern .....	157
Create AB line using 2 points .....	158
Create AB line using Current Location and Heading .....	158
Create AB line using Current Location and Inputting Heading .....	158
<b>New Pattern—Identical Curve .....</b>	<b>159</b>
Select Pattern .....	159
<b>New Pattern—Pivot .....</b>	<b>159</b>
Select Pattern .....	160
Pivot Shift .....	160
Create AB line using driven path .....	160
<b>New Pattern—SmartPath® .....</b>	<b>162</b>
Select SmartPath .....	162
Inputting Paths into SmartPath .....	162
Cycle between Loaded Paths .....	163
Select a Previous SmartPath Pass .....	164

---

SmartPath Guidance Options .....	164
Path Smoothing .....	165
Boundary Guidance .....	166
Boundary Guidance Options .....	166
CartACE™ .....	166
CartACE - FollowPath™ .....	167
Re-center/Nudge .....	169
Live Grain Tank Reset Sensor .....	169
AutoSave .....	170
Loading a Guidance Pattern .....	171
Manage Patterns .....	171
Spatial Sort .....	171
Import Pattern .....	172
Export Pattern .....	172
Edit Pattern .....	172
Remove Pattern/Remove All Patterns .....	172
Reset Pattern .....	172
Pattern Groups .....	173
Guidance Options .....	174
Save .....	174
Pause .....	174
Remark A .....	175
Nudge .....	175
Shift .....	176
Steering .....	177
Lightbar .....	178
Tramlines .....	179
Tramline Adjust .....	180
Access Path .....	180

## TurnPath

<b>TurnPath .....</b>	<b>183</b>
<b>TurnPath Requirements .....</b>	<b>183</b>
<b>TurnPath Single Turn Mode Toolbox .....</b>	<b>183</b>
<b>TurnPath Preview .....</b>	<b>184</b>
TurnPath Radius .....	185
Overshoot .....	185
Boundary Distance .....	185
Headland Size .....	185
Reset .....	186
<b>TurnPath Options .....</b>	<b>186</b>
Auto Flip Direction .....	186
Countdown Distance .....	186
Initial Turn Option .....	186
<b>Sequence Mode .....</b>	<b>187</b>
Sequence Mode Toolbox & Rolodex .....	187
<b>Sequences .....</b>	<b>189</b>
Identical Groups .....	189
Alternate Groups .....	190
Skip Pass .....	190
Harvest .....	191

## Summary Reports

<b>Summary Report .....</b>	<b>193</b>
<b>Event Summary .....</b>	<b>196</b>

---



Field Notes .....	196
<b>Conditions</b> .....	<b>196</b>
<b>Equipment</b> .....	<b>197</b>
<b>Product</b> .....	<b>197</b>
<b>Memo</b> .....	<b>197</b>
<b>Smart Reports™ (InCommand™ 1200 Only)</b> .....	<b>199</b>
Create Reports .....	199
Smart Report Auto-Generation .....	200
Export Reports .....	200
Control Channel Report Content .....	201
View Reports .....	202
View Map .....	203

## Ag Leader Display–Auxiliary Assignments

<b>Enable the Universal Terminal</b> .....	<b>205</b>
ISOBUS Settings .....	205
Task Controller .....	205
ISO Load and Go .....	205
File Server .....	206
Common Terminology .....	206
<b>Auxiliary Assignments</b> .....	<b>207</b>
<b>Auxiliary Module Support</b> .....	<b>211</b>

## ISO Retrofit Kit

Universal Terminal .....	213
Task Controller .....	213
ISO Load and Go .....	213
File Server .....	214
Common Terminology .....	214
Auxiliary Assignment .....	217
UT Alarms and Trouble Codes .....	217
<b>ISOBUS Retrofit—No Modules</b> .....	<b>219</b>
<b>Retrofit Cable Kit (Generic Tractor) Wiring Diagram</b> .....	<b>220</b>
<b>Troubleshooting Step 1: Universal Terminal</b> .....	<b>221</b>
<b>Troubleshooting Step 2: Cables and Power</b> .....	<b>222</b>
<b>Troubleshooting Step 3: ISOBUS Retrofit Cable</b> .....	<b>223</b>
<b>Troubleshooting Step 4: High Current Relay Module</b> .....	<b>224</b>
<b>Troubleshooting Step 5: CAN Power Module LED 1</b> .....	<b>225</b>
<b>Troubleshooting Step 6: CAN Power Module LED 2</b> .....	<b>226</b>
<b>Troubleshooting Step 7: CAN Power Module LED 3</b> .....	<b>227</b>
<b>Troubleshooting Step 8: Reload Implement Object Pools</b> .....	<b>228</b>

## Intellislope® Tile Plow Control System

<b>Intellislope® Tile Plow Control System</b> .....	<b>231</b>
Installation .....	231
Components and Identification .....	231
Plow Harness .....	232
Water Management Module .....	234
GPS .....	235
GPS Receiver Configuration .....	235
<b>Create Configurations</b> .....	<b>236</b>
Configuration Wizard .....	236
<b>Setup Tile Controller</b> .....	<b>236</b>
Configuration Setup .....	236
Implement Offsets .....	237

---

Water Management .....	237
Ongoing Pitch Zero Adjustment .....	240
Plow Starting Numbers .....	240
Rule of Adjustments .....	240
Hydraulic Pressure and Hose Hookup .....	242
Hydraulics Check .....	243
Roll Calibration .....	244
Pitch Calibration .....	245
Look-Ahead Distance .....	245
Antenna Offsets .....	246
<b>Topography .....</b>	<b>246</b>
Topography screen .....	247
Red, white, blue scheme .....	249
Brown-Tan scheme .....	249
<b>Survey .....</b>	<b>250</b>
About Surveying .....	250
Surveying With a Vehicle (Not With Plow) .....	250
Surveying with Plow .....	251
Managing Surveys .....	253
<b>Operating Modes .....</b>	<b>253</b>
Installing with AutoTile® .....	255
Modify AutoTile Design .....	256
Switch Start Button .....	257
Reverse Outlet Command .....	258
Adjusting Profile to allow Tiling .....	259
Tile Type .....	260
Select Tile Product .....	260
Creating Tile Products .....	261
Start Depth Message .....	262
AutoTile in Process .....	263
<b>On-grade Indication .....</b>	<b>263</b>
Stop Install .....	264
<b>Grade Control .....</b>	<b>264</b>
Running Grade Control .....	264
<b>Target .....</b>	<b>266</b>
On-grade Indication .....	267
<b>Pitch Control .....</b>	<b>267</b>
Running Pitch Control .....	268
<b>Diagnostics .....</b>	<b>270</b>
Devices .....	270
GPS .....	270
Lessons Learned and Pitfalls to Avoid .....	271
 <b>Planting Section Control</b>	
<b>Planting Section Control .....</b>	<b>275</b>
<b>Map View .....</b>	<b>275</b>
<b>Create Configuration .....</b>	<b>276</b>
<b>Load Configuration .....</b>	<b>276</b>
<b>Creating Products .....</b>	<b>276</b>
Configuration Setup .....	277
Automatic AutoSwath Control .....	278
Look-Ahead Settings .....	279
<b>Row Shutoff Look-Ahead Numbers .....</b>	<b>280</b>
Checking AutoSwath Performance for Row Shutoff .....	280

---

Auxiliary Input .....	282
<b>Clutch Diagnostics .....</b>	<b>283</b>
<b>Troubleshooting Planter Section Control .....</b>	<b>283</b>
Fixing Overplanting and Underplanting in AutoSwath .....	284

## Hydraulic Seed Rate Control

Load Configuration .....	285
<b>Map View .....</b>	<b>285</b>
Product Control Toolbox .....	286
Rate Control Settings .....	287
<b>Loading Prescriptions .....</b>	<b>288</b>
Shape File Conversion .....	289
<b>Creating Products .....</b>	<b>290</b>
<b>Create Configuration .....</b>	<b>291</b>
<b>Equipment Settings .....</b>	<b>291</b>
<b>Auxiliary Input .....</b>	<b>292</b>
<b>Hydraulic Seed Rate Control .....</b>	<b>294</b>
Controller Settings for Hydraulic Seed Rate Motor Drives .....	294
Channel Tab settings .....	295
Control Valve Settings - PWM .....	296
Control Valve Settings - Servo .....	296
Auxiliary Tab settings .....	297
Hydraulic Seed Controller Settings for Specific Planters .....	297
Hydraulic Seed Meter Calibration Numbers .....	298
<b>Stepper Seed Rate Control .....</b>	<b>299</b>
Controller Settings for Stepper Seed Rate Motor Drives .....	300
Channel Tabs .....	300
<b>Gear Ratio Calculations for Seed Rate Motors .....</b>	<b>301</b>
Seed Ratio Calculation Example Procedure .....	301
Gear Ratio Drawing - For Multiple Drive Combinations .....	303
Seed Ratio Calculation Example Procedure for Shaft Drives .....	303
Gear Ratio Drawing Shaft Drives .....	304
Planter Options .....	305
Priming Seed Rate Meters .....	306
Calibrating Seed Rate Meters .....	306
<b>Troubleshooting .....</b>	<b>309</b>
Hydraulic Seed Control: Zero Flow Offset Variation .....	309
Stepper Seed Control Meter Alarms .....	310

## Hydraulic Down Force–2 Channel

Load Configuration .....	311
<b>Map View .....</b>	<b>311</b>
Bar Graphs on Run Screen .....	312
Planter Performance Screen .....	312
Down Force Status .....	313
Planter Options Screen .....	314
Gauge Wheel Load .....	315
Create Configuration .....	316
<b>Setup Down Force Configuration .....</b>	<b>317</b>
<b>Down Force screen General tab .....</b>	<b>317</b>
<b>Down Force Channel 1 and Channel 2 tabs .....</b>	<b>319</b>
Calibrate Pressure Sensor .....	320
Down Force Diagnostics screen .....	322
<b>Down Force Alarms .....</b>	<b>322</b>
How to use Manual Override .....	324

---

<b>FAQ .....</b>	<b>325</b>
<b>Troubleshooting .....</b>	<b>327</b>
Implement Switch Adjustment Problems .....	328
<b>ISOBUS Hydraulic Down Force</b>	
<b>ISOBUS Hydraulic Down Force .....</b>	<b>331</b>
At a Glance—Universal Terminal .....	331
Planter Average Run Screen .....	331
Gauge Wheel Load Bar Graph .....	331
Supplemental Force Bar Graph .....	332
<b>At a Glance – With Ag Leader InCommand™ 1200 .....</b>	<b>332</b>
Gauge Wheel Load Map .....	332
Supplemental Down Force Map .....	333
Bar Graph .....	333
<b>ISOBUS Down Force Configuration .....</b>	<b>334</b>
<b>ISOBUS Down Force Operation .....</b>	<b>338</b>
<b>ISOBUS Down Force Settings .....</b>	<b>340</b>
Gauge Wheel Settings .....	340
Force Settings .....	341
Alarm Settings .....	342
System Settings .....	342
ISOBUS Down Force Diagnostics .....	342
ISOBUS Down Force Tools .....	344
Down Force Alarms .....	344
<b>How to use Manual Override .....</b>	<b>345</b>
<b>FAQ .....</b>	<b>346</b>
<b>Troubleshooting .....</b>	<b>348</b>
<b>Implement Switch Adjustment Problems .....</b>	<b>350</b>
Module Diagnostic Lights .....	351
<b>Hydraulic Down Force—Individual Row</b>	
Load Configuration .....	353
<b>Map View .....</b>	<b>354</b>
Bar Graphs on Run Screen .....	355
Planter Performance Screen .....	355
Down Force Status .....	356
Planter Options Screen .....	357
Gauge Wheel Load .....	357
Create Configuration .....	358
<b>Setup Down Force Configuration .....</b>	<b>359</b>
<b>General tab .....</b>	<b>360</b>
Down Force Mode .....	360
<b>Uplift Force .....</b>	<b>361</b>
Calibrate Pressure Sensor .....	361
Calibrate Pressure Sensor: .....	362
<b>Advanced tab .....</b>	<b>363</b>
Monitoring Planter Rows in Conjunction with Controlled Rows .....	364
Diagnostics Screen .....	364
<b>Down Force Alarms .....</b>	<b>365</b>
How to use Manual Override .....	366
<b>FAQ .....</b>	<b>368</b>
<b>Troubleshooting .....</b>	<b>369</b>
Implement Switch Adjustment Problems .....	370
Module Diagnostic Lights .....	371
Implement Switch Status Indicator .....	372

---

Planter Row Control Module-Indexing Error Screens .....	373
---	-----

## **Ag Leader Seed Tube Monitoring Module**

<b>Ag Leader Seed Tube Monitoring Module .....</b>	<b>377</b>
Load Configuration .....	377
<b>Map View .....</b>	<b>377</b>
Advanced Seed Monitoring .....	378
Bar Graph .....	378
<b>Advanced Seed Monitoring .....</b>	<b>378</b>
Planter Performance screen .....	379
<b>Creating Products .....</b>	<b>380</b>
<b>Create Configuration .....</b>	<b>381</b>
<b>Seed Monitor Setup .....</b>	<b>382</b>
AutoConfig Procedure .....	382
STMM Split-Row Configurations .....	384
Seed Monitor Alarms .....	384
Planter Options .....	385
Legend Setup .....	387
Seed Monitor Diagnostics .....	388
<b>Troubleshooting Ag Leader Seed Tube Monitoring Module .....</b>	<b>388</b>
Singulation Errors .....	390
Spacing Quality Errors .....	391

## **Standard KINZE Planter Module**

Load Configuration .....	393
<b>Map View .....</b>	<b>393</b>
Planter Performance Screen .....	395
<b>Creating Products .....</b>	<b>395</b>
<b>Setup Steps .....</b>	<b>396</b>
<b>Create Configuration .....</b>	<b>397</b>
KINZE Planter Configuration .....	397
Muxbus Sensor Detection .....	399
KINZE Sensor Configuration .....	402
Sensor Information .....	403
KINZE Seed Monitor Alarms .....	403
KINZE Magnetic Coil Speed Sensor Calibration .....	404
KINZE EdgeVac Calibration .....	405
Standard KINZE Planter Module Options .....	406
Planter Monitor Diagnostics .....	406
KINZE Display Items in Map View .....	407
<b>Troubleshooting .....</b>	<b>408</b>
How to replace a failed MUXBUS sensor .....	408
Alarms on Standard KINZE Planter Module .....	409

## **SureDrive®**

<b>Load Configuration .....</b>	<b>413</b>
<b>Map View .....</b>	<b>413</b>
Product Control Toolbox .....	414
Rate Control Settings .....	416
Turn Compensated Rate Control .....	417
<b>Loading Prescriptions .....</b>	<b>417</b>
Shape File Conversion .....	418
Advanced Seed Monitoring .....	420
Bar Graph .....	420
<b>Advanced Seed Monitoring .....</b>	<b>421</b>

---

Planter Performance screen .....	421
<b>Creating Products .....</b>	<b>423</b>
<b>Create Configuration .....</b>	<b>424</b>
<b>Planter Options .....</b>	<b>424</b>
Seed Monitor .....	424
Population Alarms .....	426
<b>Sensor Configuration .....</b>	<b>427</b>
<b>Vacuum &amp; Pressure Configuration .....</b>	<b>427</b>
Planter Drives .....	428
Priming Seed Rate Meters .....	429
Legend Setup .....	431
<b>Seed Rows .....</b>	<b>432</b>
Automatic AutoSwath Control .....	435
Look-Ahead Settings .....	436
<b>Configuring Offset Planter Sections .....</b>	<b>437</b>
Checking AutoSwath Performance for Row Shutoff .....	439
<b>Fixing Overplanting and Underplanting in AutoSwath .....</b>	<b>440</b>
AutoSwath Function—Turn Off Look Ahead .....	440
AutoSwath Function—Turn On Look Ahead .....	440
SureDrive Alarms .....	440
Diagnostic Screens .....	441
FAQ .....	443
SureDrive Indicator Lights .....	444
Module Diagnostic Lights .....	445
Implement Switch Status Indicator .....	449
<b>Troubleshooting Seed Monitor .....</b>	<b>451</b>
Singulation Errors .....	452
Spacing Quality Errors .....	453

## SureSpeed

<b>SureSpeed® .....</b>	<b>457</b>
<b>Load Configuration .....</b>	<b>457</b>
<b>Map View .....</b>	<b>458</b>
Product Control Toolbox .....	459
Rate Control Settings .....	460
Turn Compensated Rate Control .....	461
<b>Loading Prescriptions .....</b>	<b>461</b>
Shape File Conversion .....	462
Advanced Seed Monitoring .....	464
Bar Graph .....	464
<b>Advanced Seed Monitoring .....</b>	<b>465</b>
Planter Performance screen .....	466
<b>Creating Products .....</b>	<b>467</b>
<b>Create Configuration .....</b>	<b>468</b>
<b>Planter Options .....</b>	<b>469</b>
Seed Monitor .....	469
Population Alarms .....	470
Planter Drives .....	472
Priming Seed Rate Meters .....	473
Planter Check .....	474
Planter Check Success .....	475
Planter Check Failure Detected .....	476
Planter Test Stand .....	476
Legend Setup .....	478

<b>Seed Rows</b> .....	<b>479</b>
Automatic AutoSwath Control .....	482
Look-Ahead Settings .....	483
<b>Configuring Offset Planter Sections</b> .....	<b>484</b>
Checking AutoSwath Performance for Row Shutoff .....	486
<b>Fixing Overplanting and Underplanting in AutoSwath</b> .....	<b>487</b>
AutoSwath Function—Turn Off Look Ahead .....	487
AutoSwath Function—Turn On Look Ahead .....	487
No Seed Flow - The seed sensor does not detect any seed flow. ....	487
SureSpeed Alarms .....	487
<b>Diagnostic Screens</b> .....	<b>489</b>
<b>Row Control Module</b> .....	<b>490</b>
Seed Meter .....	490
Seed Monitoring .....	491
Delivery Tube .....	492
Seed Sensor .....	492
Planter Control Module .....	493
Frequently Asked Questions (FAQ) .....	493
<b>SureSpeed Indicator Lights</b> .....	<b>494</b>
<b>Planter Control Module 2 (PCM2)</b> .....	<b>494</b>
Alternator Management Circuit (AMC) .....	497
Row Control Module 2 (RCM2) .....	497
Implement Switch Module .....	499
Seed Tube Sensor .....	500
Meter and Delivery System Motors .....	500
<b>RCM Errors</b> .....	<b>501</b>

## **SureSpeed™ Operators Manual**

Safety and Notices .....	505
Special Considerations .....	506
John Deere MaxEmerge™ Plus and MaxEmerge™ 2, White 8000 and 9000 series, row units .....	506
<b>Operation</b> .....	<b>506</b>
Meter Disassembly .....	506
Delivery Tube Disassembly .....	510
Delivery Tube Inspection .....	510
PreSeason Checklist .....	511
Belt Tension Adjustment .....	512
Visual Belt Tension Inspection .....	512
Properly Tensioned Belt Characteristics .....	513
Under Tensioned Belt Characteristics .....	514
Crop Settings .....	515
Recommended Vacuum Levels .....	516
Recommended Vacuum Levels for Corn .....	516
Recommended Vacuum Level for Soybeans .....	518
<b>Meter Speed RPMs</b> .....	<b>519</b>
<b>(30" Row Spacing 92 Cell Soybean Disc) or</b> .....	<b>519</b>
<b>(15" Row Spacing 46 Cell Soybean Disc)</b> .....	<b>519</b>
<b>Recommended Vac Chart for Soybeans (Single Row and Dual Row)</b> .....	<b>520</b>
Recommended Vacuum Level for Soybean, Cotton, Sugar beet/Milo .....	521
<b>Meter Speed RPMs - 20" Row Spacing 46 Cell Soybean, Cotton, Sugar beet/Milo Disc</b> .....	<b>522</b>
Meter Tuning and Adjustments .....	527
Additives .....	529
<b>Maintenance</b> .....	<b>531</b>
End of Season Care .....	533

---

Seed Belt Tension Adjustment .....	535
Seed Belt Replacement .....	535
Brush Wheel Replacement .....	536
<b>Diagnostics .....</b>	<b>536</b>
Troubleshooting Checklist .....	536
RCM II Run Switch .....	538
Troubleshooting .....	539
<b>Parts List .....</b>	<b>542</b>
Delivery Tube .....	542
Meter .....	546
Klnze 4000 Series Hopper .....	549
John Deere Mini-Hopper .....	552

## Hydraulic Down Force–SureForce™

Load Configuration .....	555
<b>Map View .....</b>	<b>556</b>
Bar Graphs on Run Screen .....	557
<b>Advanced Seed Monitoring .....</b>	<b>557</b>
Planter Performance screen .....	557
Down Force Status .....	559
Planter Options Screen .....	560
Gauge Wheel Load .....	561
Create Configuration .....	562
<b>Setup Down Force Configuration .....</b>	<b>563</b>
<b>General tab .....</b>	<b>563</b>
Hydraulic Bleed .....	564
Calibrate Pressure Sensor .....	565
Calibrate Pressure Sensor: .....	566
<b>Advanced tab .....</b>	<b>566</b>
Monitoring Planter Rows in Conjunction with Controlled Rows .....	567
Diagnostics Screen .....	568
<b>Down Force Alarms .....</b>	<b>568</b>
SureForce/SureDrive Voltage Alarms .....	568
<b>FAQ .....</b>	<b>571</b>
<b>Troubleshooting .....</b>	<b>573</b>
Implement Switch Adjustment Problems .....	573
Module Diagnostic Lights .....	574
Implement Switch Status Indicator .....	576
Planter Row Control Module-Indexing Error Screens .....	577

## Liquid Rate Control

Load Configuration .....	581
<b>Map View .....</b>	<b>581</b>
<b>Product Control Toolbox .....</b>	<b>582</b>
<b>Rate Control Settings .....</b>	<b>583</b>
<b>Container Level Settings .....</b>	<b>584</b>
Tank Alarms .....	585
<b>Loading Prescriptions .....</b>	<b>586</b>
Shape File Conversion .....	587
<b>Creating Products .....</b>	<b>588</b>
Creating Single Products .....	588
Creating Product Template .....	589
Configure Product Mix .....	591
Create Configuration .....	593
<b>Implement Offsets .....</b>	<b>594</b>

---



---

<b>Equipment Settings</b> .....	<b>596</b>
<b>Auxiliary Input</b> .....	<b>597</b>
Fence Row Nozzle Indicators .....	598
<b>Hardi Safe Track</b> .....	<b>599</b>
<b>Liquid Application Controller Settings</b> .....	<b>600</b>
Control Valve Settings - PWM .....	601
Control Valve Settings - Servo, Calibrated Reflow and Ramsey Valve .....	602
Calibrate Pressure .....	603
<b>Liquid Application Diagnostics</b> .....	<b>603</b>
<b>Troubleshooting DirectCommand Liquid Applications</b> .....	<b>604</b>
Troubleshooting Serial Control Applications .....	607
John Deere Specific Instructions .....	608
Control Valve Settings .....	609
Liquid Product Control Valve Configuration Options .....	609
Servo Control Valve Settings (By Manufacturer) .....	610
Dickey-John NH3 Conversions .....	612
Fertilizer default Product Settings .....	613
Glossary of Application Settings .....	613
Configuration Settings .....	613
Speed Input Settings .....	614
Automatic Swath Control Settings .....	614
Auxiliary Input Settings .....	614
Controller Settings .....	615

## Serial Communication

<b>Load Configuration</b> .....	<b>617</b>
<b>Map View</b> .....	<b>617</b>
<b>Product Control Toolbox</b> .....	<b>618</b>
<b>Rate Control Settings</b> .....	<b>619</b>
<b>Container Level Settings</b> .....	<b>620</b>
<b>Adjust Container Amount</b> .....	<b>621</b>
Tank Alarms .....	621
<b>Loading Prescriptions</b> .....	<b>622</b>
Shape File Conversion .....	623
<b>Creating Products</b> .....	<b>625</b>
Creating Single Products .....	625
Creating Product Template .....	626
Configure Product Mix .....	628
<b>Create Configuration</b> .....	<b>630</b>
<b>Implement Offsets</b> .....	<b>632</b>
<b>Equipment Settings</b> .....	<b>634</b>
<b>Module Layouts</b> .....	<b>634</b>
<b>Serial Control - Supported Controllers</b> .....	<b>635</b>
<b>Troubleshooting Serial Control Applications—Liquid</b> .....	<b>637</b>
<b>Troubleshooting Serial Control Applications—Granular</b> .....	<b>637</b>

## ISO Liquid Rate Control

ISO Liquid Initial Setup Checklist .....	639
<b>At a Glance—Universal Terminal</b> .....	<b>641</b>
<b>At a Glance—With Ag Leader Display</b> .....	<b>641</b>
<b>At a Glance—With Ag Leader Display</b> .....	<b>642</b>
Liquid Control Options .....	642
Load Configuration .....	643
Map View .....	643
Product Control Toolbox .....	644

---

Rate Control Settings .....	645
Container Level Settings .....	646
Tank Alarms .....	647
<b>Loading Prescriptions .....</b>	<b>648</b>
Shape File Conversion .....	649
<b>Creating Products .....</b>	<b>651</b>
Creating Single Products .....	651
Creating Product Template .....	652
Configure Product Mix .....	654
<b>Create Configuration .....</b>	<b>657</b>
<b>Implement Offsets .....</b>	<b>657</b>
<b>Hardi Safe Track .....</b>	<b>659</b>
UT Runscreen .....	660
Product Density .....	661
Rate Control Settings .....	662
Speed Source Settings .....	663
Auxiliary Speed Source .....	664
Actual Rate Settings .....	665
System Settings screen .....	665
Universal Pressure Sensor .....	666
Vapor State Monitoring .....	667
Pressure, Temperature, and RPM readings .....	667
Tank Capacity .....	668
Fill, Set, or Empty Tank .....	668
Container Alarms .....	669
NH3 Tank Capacity .....	670
Nozzles .....	670
Section Indicators .....	671
Manage Components .....	672
Profiles .....	672
Add Profile .....	672
Delete Profile .....	678
Set Active Profile .....	679
<b>Nozzles .....</b>	<b>680</b>
Add Nozzle .....	680
Delete Nozzle .....	681
Controller Settings .....	682
PWM Settings Tool .....	683
Edit Look-Ahead Settings .....	685
Alarm Settings .....	686
<b>System Settings .....</b>	<b>686</b>
Switch Systems .....	686
Reconfigure .....	689
Reset .....	692
UT Settings—Switch Setup .....	693
Calibration .....	693
Flow Sensor Calibration .....	693
Manual Calibration .....	695
Field Dispense Volume .....	696
Nozzle Catch Test .....	698
Static Dispense Volume .....	700
Pressure Sensor Calibration .....	702
Single Set Point Calibration .....	704
Multiple Set Point Calibration .....	707

---

Pump Speed Sensor Calibration .....	709
Speed Sensor Calibration .....	709
Temperature Calibration .....	711
<b>Diagnostics .....</b>	<b>711</b>
Module Diagnostics .....	712
ISO Liquid Control Module Diagnostics (Status) .....	712
ISO Liquid Control Module Diagnostics (Control) .....	713
ISO Swath Control Module Diagnostics (Status tab) .....	714
ISO Swath Control Module Diagnostics (Control tab) .....	715
Alarms .....	716
Unlocks .....	716
Tools .....	717
<b>ISO Liquid Module .....</b>	<b>719</b>
<b>Swath Module .....</b>	<b>719</b>

## ISOBUS Serial Communication

<b>Load Configuration .....</b>	<b>723</b>
<b>Map View .....</b>	<b>723</b>
<b>Product Control Toolbox .....</b>	<b>724</b>
Rate Control Settings .....	725
Container Level Settings .....	726
<b>Adjust Container Amount .....</b>	<b>727</b>
Tank Alarms .....	727
<b>Loading Prescriptions .....</b>	<b>728</b>
Shape File Conversion .....	729
<b>Creating Products .....</b>	<b>731</b>
Creating Single Products .....	731
Creating Product Templates .....	732
Configure Product Mix .....	734
<b>Create Configuration .....</b>	<b>736</b>
<b>Load Configuration .....</b>	<b>737</b>
<b>Implement Offsets .....</b>	<b>737</b>
<b>Equipment Settings .....</b>	<b>739</b>
Enable Universal Terminal and Task Controller .....	739
<b>Configuration Setup .....</b>	<b>741</b>
<b>Status Screen .....</b>	<b>744</b>
<b>Settings Screen .....</b>	<b>746</b>
Manage Configurations .....	746
Alarm Settings .....	747
Diagnostics .....	748
<b>Troubleshooting Serial Control Applications—Liquid .....</b>	<b>750</b>
<b>Troubleshooting Serial Control Applications—Granular .....</b>	<b>750</b>
ISO Serial Application—Support Controllers .....	752
InCommand™-Serial Bridge Module-Amp Vehicle .....	755

## Injection

<b>Map View .....</b>	<b>761</b>
<b>Create Configuration .....</b>	<b>761</b>
<b>Load Configuration .....</b>	<b>762</b>
<b>Setup Configuration .....</b>	<b>762</b>
Pump Calibration .....	762
Rate Response Warning .....	763
Flow Monitor Warning .....	763
Calibrating an Injection Pump .....	763
<b>Priming an Injection Pump .....</b>	<b>765</b>

---

<b>Injection Diagnostics</b> .....	<b>767</b>
<b>Troubleshooting</b> .....	<b>767</b>
Direct Injection: Pump Doesn't Run .....	768
BATTERY POWER PIN OUTS .....	769
Direct Injection: Pump Runs Full Speed .....	769
Digital Pump Speed Pin Outs .....	770
<b>Analog Pump Speed Sensor</b> .....	<b>770</b>
Analog Speed Pin Outs .....	770
Direct Injection: Application Error .....	770
Direct Injection: Discharge Flow Sensor Error .....	771
Discharge Flow Sensor Pin Outs .....	771
Direct Injection: Inlet Restriction .....	772
Vacuum Switch Pin Outs .....	772

## OptRx

<b>OptRx®</b> .....	<b>773</b>
Load Configuration .....	773
<b>Map View</b> .....	<b>774</b>
<b>Product Control Toolbox</b> .....	<b>774</b>
Product Control Toolbox .....	775
Create Configuration .....	776
Application Rate Table .....	776
Crop Sensor Rate Table .....	777
<b>N Algorithm Setup</b> .....	<b>777</b>
<b>Create an OptRx V.I. Reference Value</b> .....	<b>778</b>
Scan a Reference Strip .....	778
<b>Crop Sensor Settings</b> .....	<b>781</b>
Crop Sensor Setup .....	783
Algorithm Setup .....	784
Corn Settings .....	784
North American Wheat Settings .....	785
Europe Settings .....	786
<b>Override Serial Logging</b> .....	<b>788</b>
<b>Sensor Setup</b> .....	<b>788</b>
<b>Sensor Setup</b> .....	<b>789</b>
<b>Installation</b> .....	<b>789</b>
<b>Glossary of OptRx Terminology</b> .....	<b>790</b>
<b>Troubleshooting OptRx Error Messages</b> .....	<b>791</b>

## Norac UC5

<b>Norac Unlock</b> .....	<b>795</b>
Locked or Unlocked .....	795
<b>Create Configuration</b> .....	<b>796</b>
<b>Setup Configuration</b> .....	<b>796</b>
General Tab .....	799
Sensor Tab .....	800
Valve Tab .....	800
Switch Tab .....	801
<b>Load Configuration</b> .....	<b>801</b>
<b>Engage button</b> .....	<b>801</b>
<b>Boom Height Control Options Button</b> .....	<b>802</b>
<b>Boom Height Control Options Screen</b> .....	<b>803</b>
Boom Height Control Options .....	803
<b>Boom Height Diagnostics</b> .....	<b>803</b>
UC5 Stand-Alone System .....	805

---

UC5 Self-Propelled with Modules .....	806
UC5 ISOBUS Vehicle .....	807

## Spreader

<b>Spinner Spreaders .....</b>	<b>809</b>
Load Configuration .....	809
<b>Map View .....</b>	<b>809</b>
Product Control Toolbox .....	810
Rate Control Settings .....	811
Container Level Settings .....	812
<b>Adjust Container Amount .....</b>	<b>813</b>
Tank Alarms .....	813
<b>Loading Prescriptions .....</b>	<b>814</b>
Shape File Conversion .....	815
<b>Creating Products .....</b>	<b>817</b>
Creating Single Products .....	817
Creating Dry Fertilizer Blends .....	818
<b>Configure Product Mix .....</b>	<b>820</b>
<b>Create Configuration .....</b>	<b>822</b>
<b>Container Sequencing .....</b>	<b>823</b>
Container Sequencing Configuration .....	823
Map Screen .....	825
<b>Equipment Settings .....</b>	<b>827</b>
Rate Outside of Field .....	828
<b>Auxiliary Input .....</b>	<b>828</b>
Controller Settings .....	831
Spreader Control: PWM Control Valve .....	831
Spreader Control: Servo Control Valve .....	832
Spreader Control: Spinner Tab .....	833
<b>Stepper Spreader Control .....</b>	<b>834</b>
Automatic Spinner Control .....	835
<b>Run Time Operations—Spreader Control .....</b>	<b>835</b>
Spreader Control screen .....	835
Conveyor Rate Look-Up .....	836
Spreader Control .....	837
Conveyor Rate .....	837
<b>Spreader Control: Routine Operations .....</b>	<b>838</b>
Spreader Control: Chain Oiler .....	838
Spreader Control: Static Calibration .....	838
Spreader Control: In-Field Calibration .....	839
Troubleshooting DirectCommand Granular Applications .....	840
Troubleshooting Serial Control Applications .....	842

## Strip Till

Load Configuration .....	843
<b>Map View .....</b>	<b>843</b>
<b>Product Control Toolbox .....</b>	<b>844</b>
Rate Control Settings .....	845
Container Level Settings .....	846
<b>Adjust Container Amount .....</b>	<b>847</b>
Tank Alarms .....	847
<b>Loading Prescriptions .....</b>	<b>848</b>
Shape File Conversion .....	849
<b>Creating Products .....</b>	<b>851</b>
Creating Single Products .....	851

Creating Dry Fertilizer Blends .....	852
<b>Configure Product Mix .....</b>	<b>853</b>
Create Configuration .....	856
Create Air Seeder Configuration .....	856
<b>Equipment Settings .....</b>	<b>857</b>
<b>Auxiliary Input .....</b>	<b>858</b>
<b>Controller Settings .....</b>	<b>859</b>
Strip Till Control: Servo Control Valve .....	860
Strip Till Control: PWM Control Valve .....	861
Linear Actuator/Clutch Settings .....	862
<b>Actuator/Clutch Logic .....</b>	<b>863</b>
Strip Till Control: Auxiliary Tab .....	864
<b>Run Time Operations .....</b>	<b>864</b>
<b>Strip Till Control Screen .....</b>	<b>865</b>
Static CFR Calibration Procedure for Hydraulic Drive systems .....	866
Static CFR Calibration Procedure for Ground Drive Systems .....	867
In-Field Calibration Procedure .....	868
Meter Prime .....	869
<b>Fertilizer Default Product Settings .....</b>	<b>871</b>
<b>Raven ISOBUS PWM Nozzle Control</b>	
Raven ISOBUS PWM Nozzle Control with the InCommand 1200 Display .....	873
Setting up Configuration for the First Time .....	873
Enable Universal Terminal and Task Controller .....	873
Create Configuration .....	875
<b>DirectCommand® L2 Rate Controller .....</b>	<b>879</b>
Load Configuration .....	879
<b>DirectCommand® L2 Rate Controller</b>	
<b>Product Control Toolbox .....</b>	<b>880</b>
Boom Prime .....	881
<b>Rate Control Settings .....</b>	<b>882</b>
Containers .....	883
Fill Flow Meters .....	883
Raven Fill Stations .....	883
Liquid Control Options .....	884
Nozzle Selection .....	885
Functionality Requiring a Custom Nozzle .....	885
Creating a Custom Nozzle .....	885
Product Density .....	887
PWM Valve Tuning Utility .....	888
Pressure Calibration .....	889
Flow Meter Calibration .....	890
Manual .....	890
Field Dispensed Volume .....	890
Nozzle Catch Test .....	890
<b>Anhydrous Ammonia (NH<sub>3</sub>) .....</b>	<b>891</b>
Load Configuration .....	891
Map View .....	891
Calibrate Temperature Sensor .....	892
Vapor State Monitoring .....	893
Tube Check .....	894
<b>Loading Prescriptions .....</b>	<b>894</b>
Shape File Conversion .....	895
<b>Creating Products .....</b>	<b>897</b>

Creating Single Products .....	897
Creating Product Template .....	898
Configure Product Mix .....	900
Create Configuration .....	901
<b>Implement Offsets .....</b>	<b>902</b>
<b>Equipment Settings .....</b>	<b>904</b>
<b>Auxiliary Input .....</b>	<b>905</b>
Fence Row Nozzle Indicators .....	906
<b>Implement Modeling .....</b>	<b>908</b>
<b>Liquid Application Controller Settings .....</b>	<b>909</b>
Controller Settings .....	909
Control Feedback .....	909
Rate Settings .....	910
Control Valve Settings - PWM .....	911
<b>Container Level Settings .....</b>	<b>912</b>
Tank Alarms .....	913
<b>Liquid Application Diagnostics .....</b>	<b>914</b>
Control Valve: .....	915
PWM Valve .....	915
Servo Valve .....	915
Auxiliary Valves .....	915
Module Power: .....	915
<b>Vehicle Interface Diagnostics .....</b>	<b>916</b>
L2 Liquid Rate Controller .....	917
Liquid Swath Module .....	918
<b>Troubleshooting DirectCommand L2 Applications .....</b>	<b>918</b>
Control Valve Settings .....	921
Liquid Product Control Valve Configuration Options .....	921
Dickey-John NH3 Conversions .....	922
Fertilizer default Product Settings .....	923
Glossary of Application Settings .....	923
Configuration Settings .....	923
Speed Input Settings .....	924
Automatic Swath Control Settings .....	924
Auxiliary Input Settings .....	924
Controller Settings .....	925
<b>Alarms .....</b>	<b>926</b>
 <b>RightSpot™</b>	
<b>RightSpot™ .....</b>	<b>927</b>
Load Configuration .....	927
Map View .....	927
<b>Product Control Toolbox .....</b>	<b>928</b>
Boom Prime .....	929
<b>RightSpot Toolbox .....</b>	<b>930</b>
<b>RightSpot™ Settings .....</b>	<b>930</b>
Rate Shift Configuration 1, 2, and 3 .....	931
Boom Recirculation .....	932
Boom Pressure Relief .....	932
<b>Rate Control Settings .....</b>	<b>933</b>
Containers .....	934
Fill Flow Meters .....	934
Raven Fill Stations .....	934
Liquid Control Options .....	935

---

Nozzle Selection .....	936
Functionality Requiring a Custom Nozzle .....	936
Creating a Custom Nozzle .....	936
Product Density .....	938
PWM Valve Tuning Utility .....	939
Valve Control Setup .....	940
Pressure Calibration .....	941
Flow Meter Calibration .....	942
Manual .....	942
Field Dispensed Volume .....	942
Nozzle Catch Test .....	942
<b>Loading Prescriptions .....</b>	<b>943</b>
Shape File Conversion .....	943
<b>Creating Products .....</b>	<b>945</b>
Creating Single Products .....	945
Creating Product Template .....	946
Configure Product Mix .....	948
Create Configuration .....	950
<b>Active Nozzles .....</b>	<b>950</b>
<b>Implement Offsets .....</b>	<b>952</b>
<b>Equipment Settings .....</b>	<b>954</b>
<b>Auxiliary Input .....</b>	<b>955</b>
Fence Row Nozzle Indicators .....	957
<b>Implement Modeling .....</b>	<b>958</b>
<b>Liquid Application Controller Settings .....</b>	<b>959</b>
Controller Settings .....	959
Control Feedback .....	959
<b>Rate Settings .....</b>	<b>960</b>
Control Valve Settings - PWM .....	961
Control Valve Settings - Servo .....	962
<b>Container Level Settings .....</b>	<b>962</b>
Tank Alarms .....	963
<b>Liquid Application Diagnostics .....</b>	<b>964</b>
Control Valve: .....	965
PWM Valve .....	965
Servo Valve .....	965
Auxiliary Valves .....	965
Module Power: .....	965
Sensors: .....	965
<b>RightSpot Diagnostics .....</b>	<b>966</b>
<b>Valve Control Modules .....</b>	<b>966</b>
<b>Vehicle Interface Diagnostics .....</b>	<b>967</b>
L2 Liquid Rate Controller LEDs .....	968
Liquid Swath Module .....	969
RightSpot Hub .....	969
Valve Control Modules .....	970
<b>Troubleshooting RightSpot Application .....</b>	<b>971</b>
Leaking or dripping when the valves should be shut off .....	971
Control Valve Settings .....	976
Liquid Product Control Valve Configuration Options .....	976
Fertilizer default Product Settings .....	977
Glossary of Application Settings .....	977
Configuration Settings .....	977
Speed Input Settings .....	978

---



Automatic Swath Control Settings .....	978
Auxiliary Input Settings .....	978
Controller Settings .....	979
<b>Alarms .....</b>	<b>980</b>

## **RightSpot™ Operator's Manual**

<b>General Guidelines .....</b>	<b>983</b>
<b>RightSpot Universal Boom Layout .....</b>	<b>984</b>
<b>Safety and Notices .....</b>	<b>985</b>
Service and Support .....	985
System and Upgrades .....	985
Automated Module Firmware Upgrade .....	985
Product Registration .....	985
<b>Operator Safety .....</b>	<b>986</b>
Symbols .....	986
Precautions .....	986
General info .....	986
Service .....	986
<b>Nozzle Selection .....</b>	<b>987</b>
<b>Pre-Season Checklist .....</b>	<b>987</b>
<b>Post-Season Checklist .....</b>	<b>988</b>
<b>Maintenance .....</b>	<b>990</b>
Disassembling and Reassembling a Nozzle Valve Assembly .....	990
Disassembling Nozzle Valves .....	990
Items to Review .....	990
Reassembling Nozzle Valves .....	991
<b>Nozzle Valve Assembly Installation .....</b>	<b>992</b>
<b>Achieving Proper Coverage with Blended Pulse™ .....</b>	<b>992</b>
<b>Boom Flush .....</b>	<b>993</b>
Performing a static boom flush .....	993
<b>Cleaning Nozzle Valves .....</b>	<b>993</b>
<b>Parts List .....</b>	<b>995</b>
Standard Valve U-clip .....	995
High Rate Valve U-clip .....	995
Service Parts and Kits for Valve Assembly. ....	996
RightSpot Hub .....	997
Valve Control Module (VCM) .....	997
<b>Diagnostics .....</b>	<b>998</b>
L2 Liquid Rate Controller .....	998
Liquid Swath Module .....	998
RightSpot Hub .....	999
Valve Control Modules .....	999
<b>Troubleshooting .....</b>	<b>1001</b>
Problem: Leaking Valves .....	1001
<b>Alarms .....</b>	<b>1002</b>
<b>Nozzle Charts .....</b>	<b>1004</b>
Standard (15 series), 20 Inch Nozzle Spacing .....	1004
Standard (15 series), 50 cm Nozzle Spacing .....	1005
High Rate (24 series), 20 Inch Nozzle Spacing .....	1006
High Rate (24 series), 50 cm Nozzle Spacing .....	1007
Map View .....	1009

## **Harvest**

(L) Harvest Status Items .....	1010
(O) Harvest Diagnostic Button on Map Screen .....	1010

---

(I) Resettable Counter .....	1011
Live Grain Tank Reset .....	1011
Calibration of Live Grain Tank Reset Counter .....	1011
Sharing Grain Tank Information with Grain Cart .....	1012
Tracking Varieties (InCommand™ 1200 Only) and Changing Regions .....	1012
(A) Region Selection .....	1013
(B) Automatic Variety Tracking .....	1013
(C) Automatic Region Changing .....	1013
In-Field Variety Tracking Messages .....	1014
(D) Importing Variety Maps .....	1014
Importing Variety Map Procedure .....	1014
Error Messages at Variety Map Import .....	1014
AutoSwath Sensitivity Settings .....	1015
Map Options .....	1015
Delay .....	1016
Create Configuration .....	1017
Load Configuration .....	1017
Harvest Calibration .....	1017
Harvest Products .....	1018
Calibrate Header Height Sensor .....	1018
Calibrate Distance .....	1018
Vibration Calibration .....	1019
Grain Weight Calibration .....	1019
Calibration Methods .....	1019
One Calibration Load .....	1020
Two Calibration Loads .....	1020
Calibration Load Flow Range .....	1020
Taking a Calibration Load .....	1020
Auto Calibration Weight Feature .....	1021
Adding and Removing Calibration Loads within Existing Calibrations .....	1021
Moisture Calibration .....	1022
Manual Moisture Setting .....	1022
Temperature Calibration .....	1023
Retiring Calibration Loads .....	1023
Selecting Weigh Device .....	1024
Certified Scale Guidelines .....	1024
Weigh Wagon Guidelines .....	1024
Grain Carts Guidelines .....	1024
Grain Cart Weighing Errors .....	1025
Harness Layout .....	1026
Display Preparation .....	1027
Harvest Pre Season Checklist .....	1027
Grain Harvest Diagnostics .....	1028
Troubleshooting Flow .....	1029
Moisture Troubleshooting .....	1030
Adjusting Proximity Switch .....	1030
Elevator Speed Troubleshooting .....	1031
Header Height Troubleshooting .....	1032
Ground Speed Troubleshooting .....	1032
<b>Harvest Interface Module .....</b>	<b>1033</b>
<b>Map View .....</b>	<b>1033</b>

## Harvest Interface Module

(K) Harvest Status Items .....	1034
--------------------------------	------

---

<b>Tracking Varieties and Changing Regions .....</b>	<b>1034</b>
(A) Region Selection .....	1035
(B) Automatic Variety Tracking .....	1035
(C) Automatic Region Changing .....	1036
In-Field Variety Tracking Messages .....	1036
(E) Importing Variety Maps .....	1036
Importing Variety Map Procedure .....	1036
Error Messages at Variety Map Import .....	1036
AutoSwath Sensitivity Settings .....	1037
Map Options .....	1038
Delay .....	1039
<b>Create Configuration .....</b>	<b>1039</b>
Load Configuration .....	1040
<b>Calibration Information .....</b>	<b>1040</b>
<b>Manual Moisture Setting .....</b>	<b>1040</b>
<b>Lexion Quantimeter .....</b>	<b>1043</b>
<b>Map View .....</b>	<b>1043</b>

## Lexion

(K) Harvest Status Items .....	1044
(O) Harvest Diagnostic Button on Map Screen .....	1044
Tracking Varieties and Changing Regions .....	1045
(A) Region Selection .....	1046
(B) Automatic Variety Tracking .....	1046
(C) Automatic Region Changing .....	1047
In-Field Variety Tracking Messages .....	1047
(D) Importing Variety Maps .....	1047
Importing Variety Map Procedure .....	1047
Error Messages at Variety Map Import .....	1047
AutoSwath Sensitivity Settings .....	1048
Map Options .....	1049
Delay .....	1050
Create Configuration .....	1050
Load Configuration .....	1051
<b>Calibration Information .....</b>	<b>1051</b>
<b>Manual Moisture Setting .....</b>	<b>1052</b>
<b>Diagnostics for Quantimeter .....</b>	<b>1052</b>
<b>Bridge Module .....</b>	<b>1053</b>
<b>Troubleshooting Quantimeter Configurations .....</b>	<b>1055</b>
<b>Jaguar Quantimeter .....</b>	<b>1057</b>
<b>Map View .....</b>	<b>1057</b>

## Jaguar

(K) Harvest Status Items .....	1058
(O) Harvest Diagnostic Button on Map Screen .....	1059
Changing Regions .....	1059
AutoSwath Sensitivity Settings .....	1061
Map Options .....	1061
Create Configuration .....	1062
Load Configuration .....	1063
<b>Calibration Information .....</b>	<b>1063</b>
<b>Diagnostics for Quantimeter .....</b>	<b>1063</b>
<b>Bridge Module .....</b>	<b>1064</b>
<b>Troubleshooting Quantimeter Configurations .....</b>	<b>1065</b>



The display is a full-featured, year-round hub for any precision farming operation. A full-color, high-brightness, high-resolution touchscreen display is easy to read and offers powerful, year-round precision farming tools. Built-in manual guidance, full-screen mapping, planter and application control, yield monitoring, real-time data logging and automated steering make up the core functionality of the display.

Read user guide completely before operating display. Understand and follow all operating and safety instructions for proper use of this display. Failure to use display properly could result in an impairment of the safety features of this product.

### End-User Licence Agreement (EULA)

This product is subject to Ag Leader Technology's End-User License Agreement (EULA), which may be found on your product's About page. The EULA includes terms that you agree to if you use this product. The About page also contains additional important information, including Ag Leader Technology's copyright and open source notices, which we recommend you review.

The About Page can be found under Setup/Display/Advanced:



### Service and Support

There are no user-serviceable parts inside the display. Contact a local Ag Leader Dealer or Distributor to setup a return for repair. For Technical Support contact local dealer or Ag Leader Support at the number below.

ph: (515) 735-7000

e-mail: [support@agleader.com](mailto:support@agleader.com)

This display has an internal lithium coin cell battery that is good for the life of the product and does not need to be replaced. There is a risk of explosion if the battery is replaced by an incorrect type. Dispose of used batteries according to the battery manufacturer's instructions.

### Color Touch-Screen

Here are a few key things to remember when using a touch screen device:

- 
- Do not use any sharp objects for running the touch screen device, this could result in damage to the display. Using the tip of a finger is the recommended method of operating the display touch screen.
  - Do not use any harsh chemicals to clean the touch screen. Using a damp soft cloth or an anti-static wipe made specifically for cleaning computer displays is the correct way to clean the screen and the enclosure.
  - The display uses a capacitive screen that is touch sensitive. It requires only a brief, gentle touch to operate correctly. A common mistake is to try to navigate too quickly through the system using firm taps instead of gentle presses.

## **Technical Specifications**

Do not exceed the specifications below:

- Storage Temperature: -22 to +176 °F (-30 to +80 °C)
- Operating Temperature: -4 to +158 °F (-20 to +70 °C)
- Operating Input Voltage: 9 –16 V DC
- Max Current Rating: 7.5 amp
- Fuse: Blade Style (ATO/ATC)
- Environmental Protection Rating: IP64
- No Protective Grounding required
- Use 150V minimum insulation rating for external circuits

Exceeding these specifications may result in degraded operation and/or damage to the display.

## **System and Upgrades**

Required software updates will be available free of charge for download automatically or can be manually downloaded at [www.agleader.com](http://www.agleader.com). It is recommended that the user check for available updates frequently to ensure display is updated.

## **Automated Module Firmware Upgrade**

In the display, all display and module firmware upgrades are packaged in a single .fw3 file. The module firmware files are stored internally in the display. A warning is shown when a module upgrade is required. All files can be upgraded in a single batch by using an upgrade screen.

---

## Product Registration

Ag Leader Technology products can be registered by one of the following methods. Registering allows the option of receiving notice of any new product updates or features.

Register at the Ag Leader Web site:

<http://www.agleader.com>

## Operator Safety

### Symbols

These symbols are used throughout the manual to designate where extra attention is necessary for the reader. The four symbols have following meaning.



**DANGER!:** This symbol means DANGER. Be very alert as safety is involved.



**WARNING!:** This symbol means WARNING. Be alert as safety can be involved.



**ATTENTION!:** This symbol means ATTENTION. This guides to better, easier and more safe operation.



**NOTE!:** This symbol means specific information applies.

### Precautions

Follow these recommended precautions and safe operating practices before using equipment.

#### General info



**DANGER!:** Read and understand this user guide before using the equipment. It is equally important that other operators of this equipment read and understand this user guide also.

If any portion of this user guide remains unclear after reading it, contact dealer for further explanation before using the equipment.



**DANGER!:** Keep children away from the equipment.

#### Service



**DANGER!:** Never service or repair the equipment while it is operating. Always replace all safety devices or shields immediately after servicing.

---

**!** **DANGER!**: Turn electrical power off before connecting and disconnecting the display and transducers, servicing or using a battery charger.

**!** **DANGER!**: If an arc welder is used on the equipment or anything connected to the equipment, disconnect power leads before welding.

**!** **DANGER!**: Do not use a high pressure cleaner to clean the electronic components.

## Display

### Display Hardware

#### Front side



**A. Light sensitivity sensor**—Used to automatically dim the display during night-time or low-light situations.

**B. Power light**—The power light displays one of three states:

Green	= ON
Pulses amber	= Standby Mode
Solid amber	= Running on battery power

**C. Built in lightbar**—for guidance

#### Side

**D. Side mount USB media slots**

(2 slots for 1200, 1 slot for 800)

Used for data transfer in and out of the display.

Used to charge mobile devices up to 1.2 amps.



## Rear

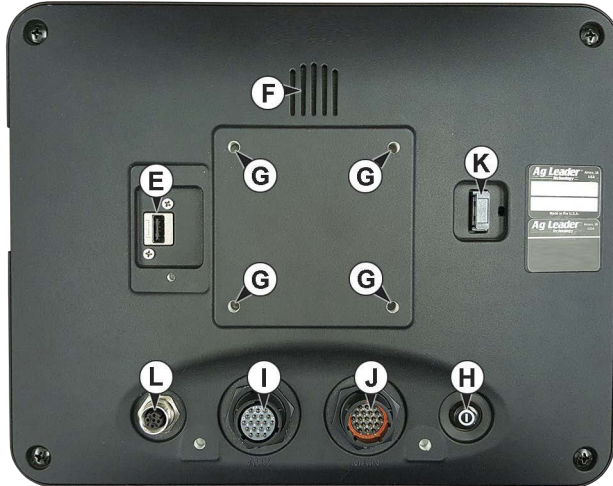

**E. WiFi**—802.11 communication

**F. Speaker**—The built-in speaker is used for audible warnings. The volume can be adjusted through the display setup routine.

**G. Mounting bracket**

### H. Power/Reset switch

The Power/Reset switch is used for turning the display on and off in installations where the system is connected to a continuous power supply.

If the display ever stops responding, the manual power switch may be held in for five seconds to restart the system. Only do this as a last resort, data loss could occur during times of improper shutdown.

**I. 19-pin auxiliary connection**—Used for camera input.

**J. 19-pin plug**—The 19-Pin round display connector contains CAN, RS-232 serial, and system power and ground connections. It is compatible with some certain other displays.

### K. HDMI OUT (1200 only)

**L. Ethernet Connection**—4-pin connection used for communication with ParaDyme, GeoSteer, SteerCommand®, OnTrac3™, SteerCommand® Z2/SteadySteer™.

## Installation Instructions

All machine installation and mounting kits are shipped with instructions specific to that kit. Instructions include special details relating to mounting, wiring and display configuration.

Mount the display securely inside the vehicle cab. The following must be considered when choosing a mounting location:

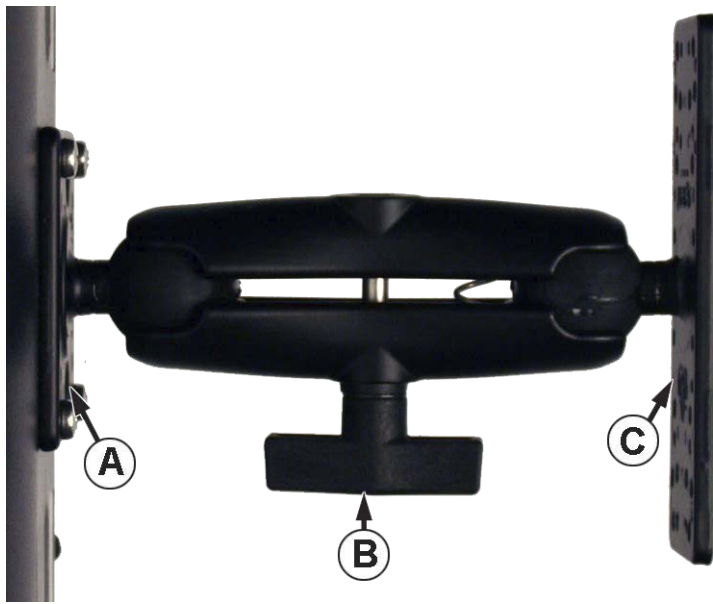

- The display must be readily accessible to the machine operator.
- The display must not obstruct the machine operator's normal driving view.
- The display must not interfere with or limit access to any of the existing machine controls.

- The CAN system cabling must be routed and secured without interfering with existing machine controls.

(A) RAM Base

(B) RAM Arm

(C) Base



**DANGER!** If drilling holes is required during the mounting process, care must be taken to insure that damage is not done to existing vehicle wiring, mechanical, or cab structure. Refer to vehicle manufacturer documentation for specific details on equipment. Follow all OEM instructions, cautions, and warnings when working around equipment.

## Fuse Installation and Replacement

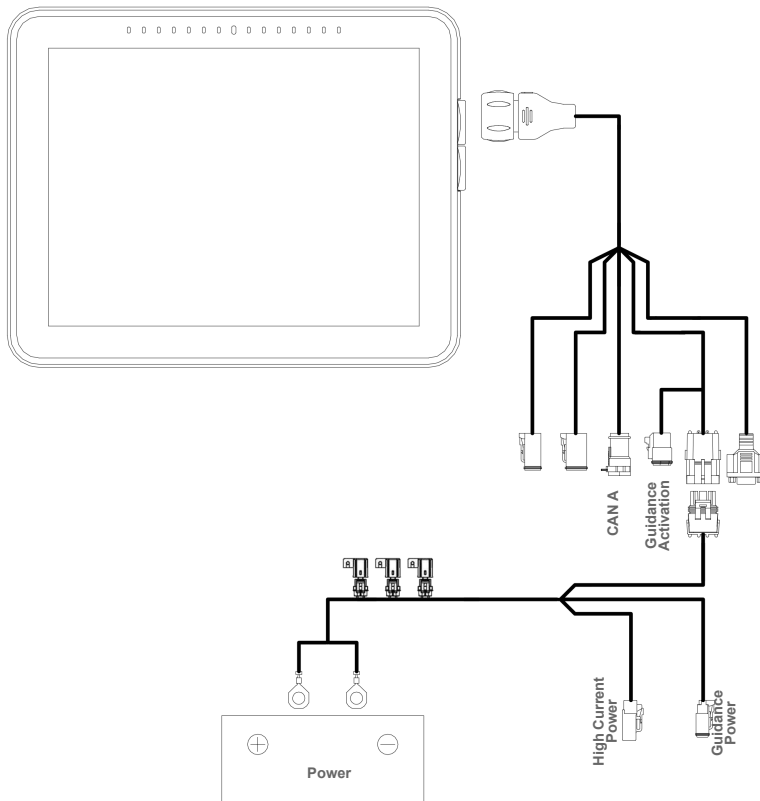

Fuse Type: Blade Style (ATO/ATC)

Rating:

- Fuse Holder (orange wire) 7.5A, 250 VAC
- Fuse Holder (pink wire) 15A, 250 VAC
- Fuse Holder 30A, 250 VAC

The fuse is to be placed in the fuse holder in-line with the battery power cable and used with display only.



---

## Initial Startup

### General info

An Initial Setup wizard is presented on startup. The wizard is presented if the display is brand new out-of-the-box.



**NOTE!:** Not all of the following parts may be required to follow - it depends on specific setup.

Once the wizard is completed, it is not shown again unless the display memory is cleared.

### Initial Setup Wizard

The Initial Setup wizard proceeds through the following setup items:

#### Time\Date, Time Zone, Unit System, Language

- Advanced Options
  - Restore Backup
  - Upgrade Firmware
  - Unlock Display Features

#### Single or Multiple Display Setup

- Single—use single display if this is the only display that is getting setup
  - Multiple Display—use multiple display if there is more than one display in the operation and the plan is to share management data between displays. After initial setup is complete, enter management information and create an .agsetup file.



**NOTE!:** Using the Restore backup option is not the proper method to get multiple displays set up to be the same. Use the .agsetup file.

It is acceptable to complete the Initial Setup wizard and then upgrade. Setup information will not change.

- On a “clean” display going out for service, to stand in for a failed display, the customer should use the Restore backup option in the Initial Setup wizard.



**ATTENTION!:** The business created on the first display, and any other management and equipment items, will be imported to the additional displays.

---

## Homescreen Layout



**Setup**—Access display's setup items



**Summary**—Used to access previously logged data, maps, reports



**Universal Terminal**—Used to interact with UT based ECU's. It must be enabled in setup



**Camera**—View cameras attached to the display. It must be enabled in setup



**Tillage**—Create configuration or start operation specific to tillage



**Planting**—Create configuration or start operation specific to planting



**Application**—Create configuration or start operation specific to application



**Harvest**—Create configuration or start operation specific to harvest



**Water Management**—Create configuration or start operation specific to water management



**Guidance**—Used to start guidance steering or CartACE operation



AgFiniti® Status Indicator



Diagnostic Status Indicator



Satellites Status Indicator

Most of the functionality of the display is not available until the basic setup process is completed.



Complete these initial configuration steps for the Run Time Environment to be active:

- Equipment Operating Configuration.
- Access Configuration Setup by pressing  or pressing an app specific to a field operation.
- Product setup
- Start Field Operation

## Status Indicators



Status Indicators are used to show different states of external equipment

connected to the display (for example: , , and ) and provides easy access to data transfer and diagnostic features of the display.

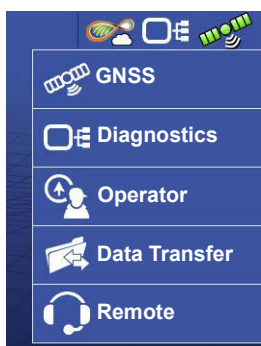

## AgFiniti Status Indicators



Connected to hotspot/network with active internet and AgFiniti connection.

- Display is ready for use with AgFiniti.



Connected to hotspot/network with internet connection, but not logged into AgFiniti.

- 
- Verify AgFiniti login credentials have been entered properly.
  - Default status when not using AgFiniti but display is connected to the internet (NTRIP RTK on InCommand).



Connected to hotspot/network with no internet connection.

- Verify hotspot has active internet connectivity.



Display has a stored hotspot/network connection but no active internet, hotspot, or AgFiniti connection.

- Verify WiFi adapter is plugged into the back of the display.
- Will only populate after a hotspot/network has saved in the display.

## Diagnostics

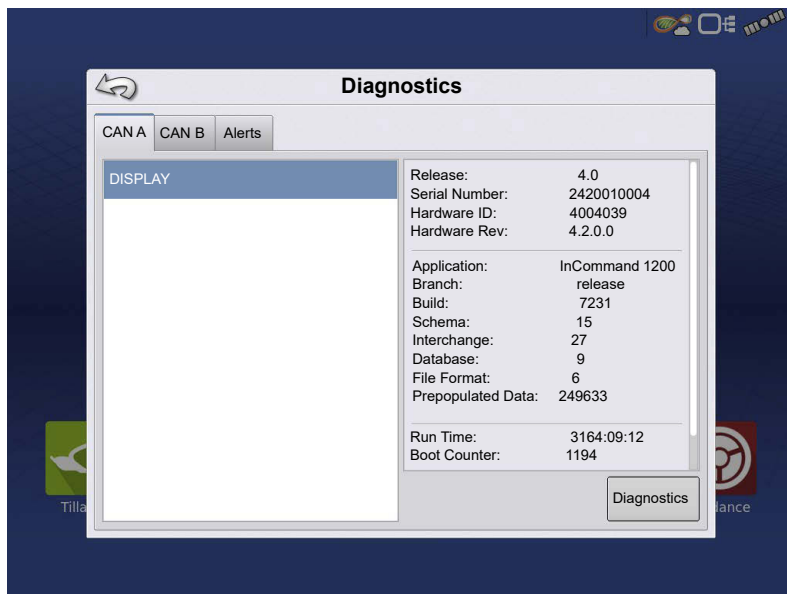

Technical support may request information from these screens for help in diagnosing a problem.

The Devices screen displays the modules that are connected to the CAN A and CAN B bus (CAN B is for ISOBUS). Select a device to display its particular firmware and hardware information.

Device Information includes:

- Firmware Version
- Firmware ID
- Hardware ID



- Serial Number
- Revision
- Run Time shown in hours:minutes:seconds
- Display Boot Counter.



**NOTE!:** Check the CAN device list to ensure that all hardware modules appear there.

## Diagnostics

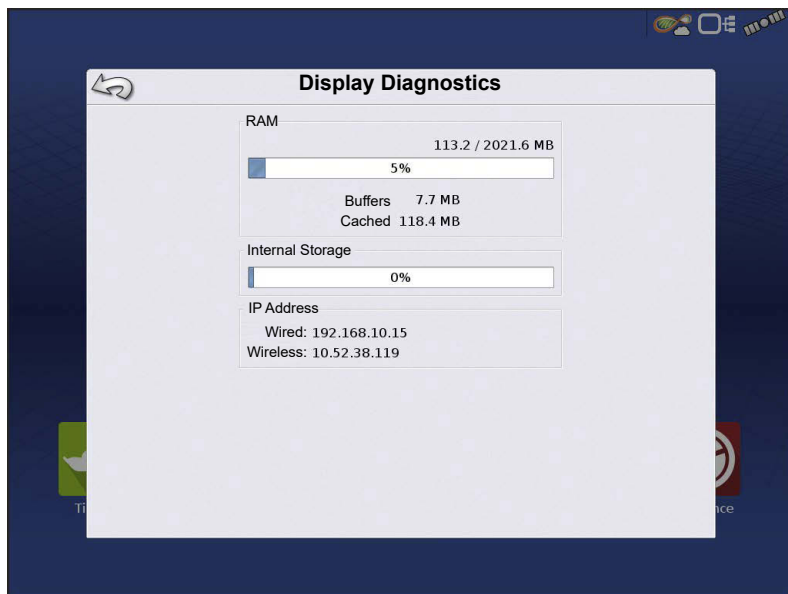

Press “Diagnostics” button to open the Display Diagnostics screen. This screen includes information about the system memory usage and available memory.

## CAN B

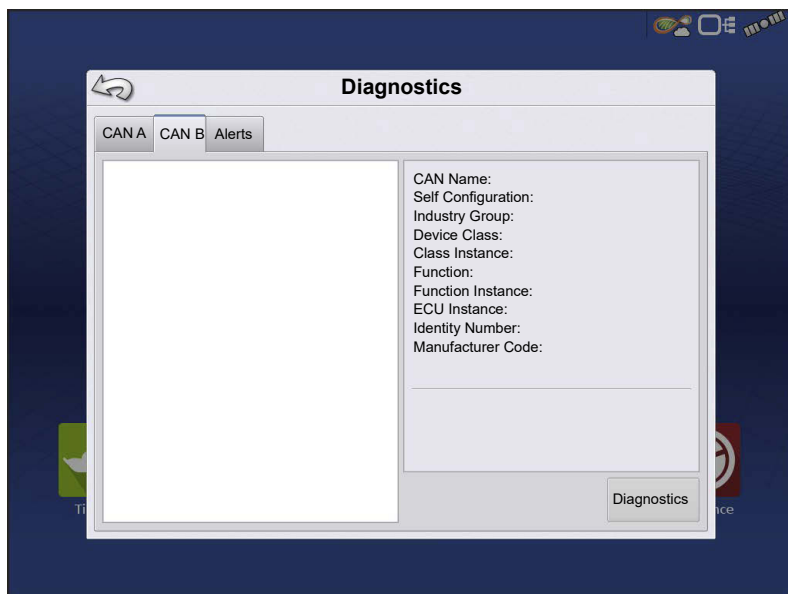

If an ISOBUS ECU is connected to the system, the ECU description will populate on the CAN B tab.

## Alerts



- Keeps history of up to 10,000 alarms/notifications
- When limit is reached oldest ones are eliminated



- Anything that appears as a red bar warning across the top of the screen
- Uncheck to hide from history list



- Anything that appears as a pop-up on the bottom center of mapping screen
- Uncheck to hide from history list

## InCommand 800 Guidance Only details

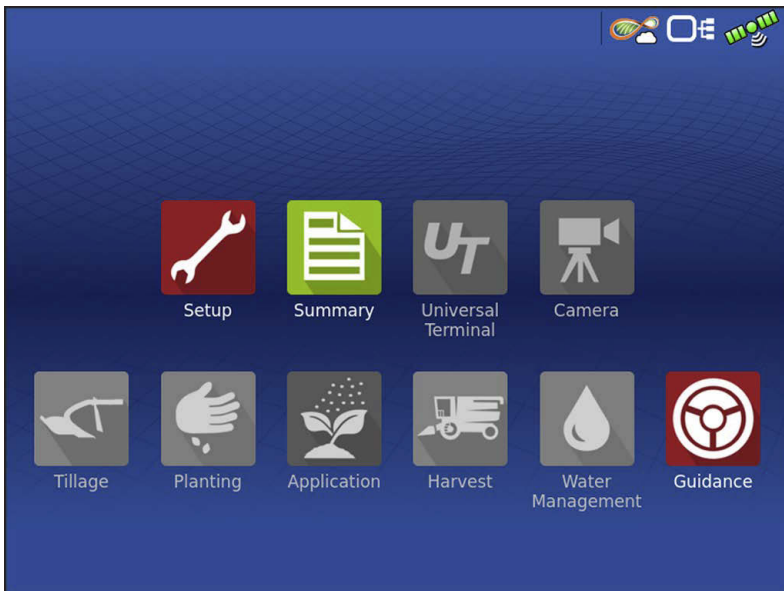

InCommand 800 Guidance Only display comes with all field apps disabled besides tillage, guidance and UT options. Contact Ag Leader dealer to unlock functionality of display.

Home screen of InCommand 800 Guidance Only

## Upgrading Display Firmware

The display firmware can be updated by:

- Automatic Firmware Updates
- Manual Updates

## Automatic Firmware Updates

Automatic firmware updates provide the ability for the display to check for updates and, if one is available, automatically install it. Requirements for automatic updates are:

- Internet connection
- Logged into free AgFiniti account
- InCommand fw 6.5 or newer

This feature is automatically turned on once FW v6.5 is installed.

For additional settings, go to

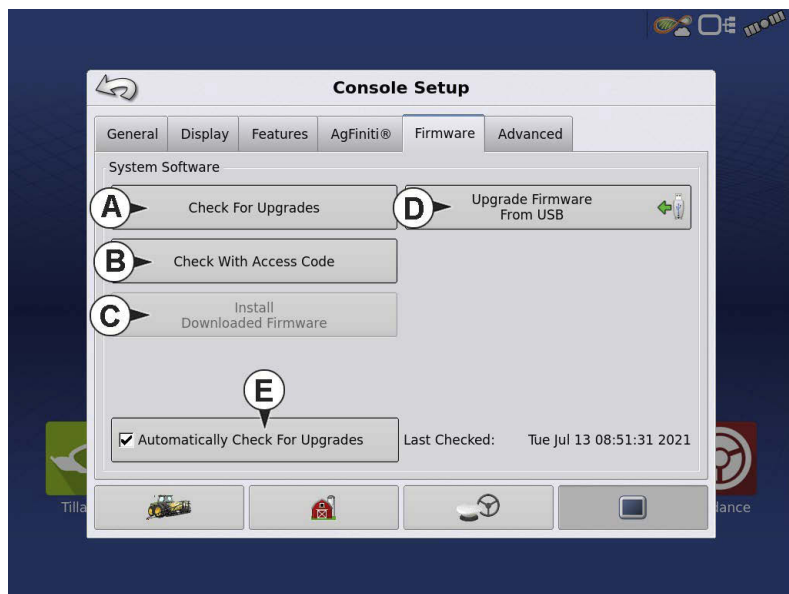

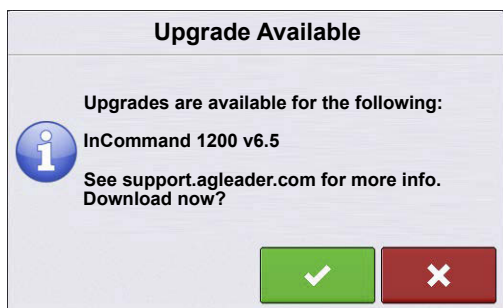

- A. Have system check for new updates
- B. Ag Leader supplied update code can be entered here
- C. If a previous update had been downloaded, use this to update
- D. Update via traditional \*.fw3 file
- E. Turn off automatic updates

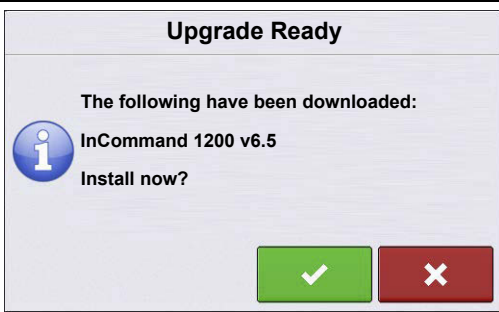

If a new update is detected a message will appear.

- Clicking  will begin the download of the update. The display can be used as normal while the download is occurring.



• Once downloaded, you can choose to start the update by clicking  or wait and use the “Install Downloaded Firmware” button from the picture shown in the image above.

- Once the update is started, the steps are the same as the manual update process.

## Manual Updates

Manual firmware updates can be preformed if

- Connection with AgFiniti is unavailable
- No account is present
- Other similar situations are present

Firmware can be downloaded from [support.agleader.com](http://support.agleader.com). Place the downloaded \*.fw3 file on a USB drive and place in display.

Navigate to



OR

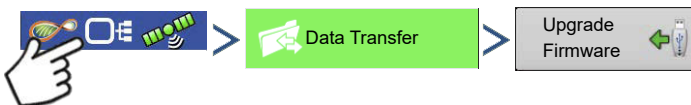

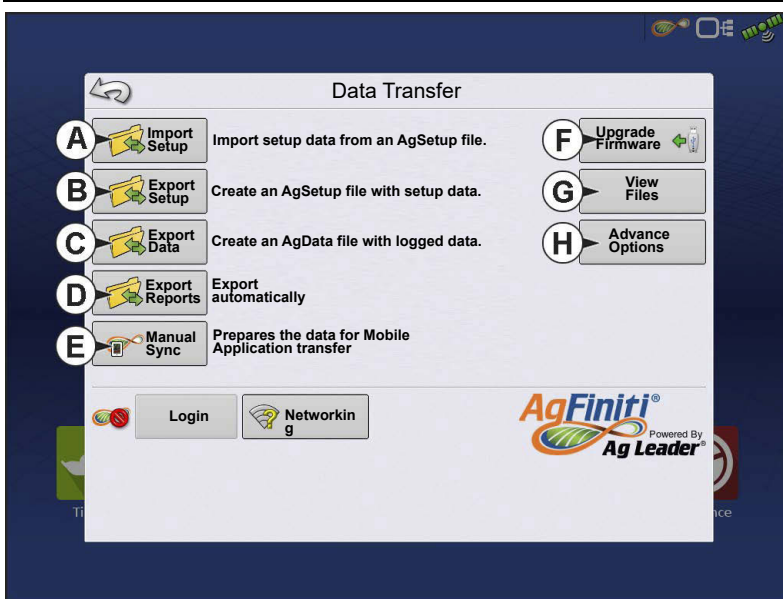

Select the update file on USB.

Press  to continue and the upgrade will begin.

Press  to confirm start of update.





The Setup buttons are shown at the bottom of the Setup screens. Toggle between screens to adjust settings for Configuration, Management, GPS, and Display.



## A. Configuration button

Press to adjust the configuration settings particular to vehicle and equipment; as well as enter and edit product information.



## B. Management button

Press to access and edit Grower, Farm, Field and Operator information.



## C. GPS button

Press to adjust Guidance settings, GPS settings, and lightbar settings.



## D. Display button

Press to adjust settings for time and date, brightness and volume settings, operating units, language, enable video, view features, and also create and restore backups.

## Equipment Setup

### Configuration tab



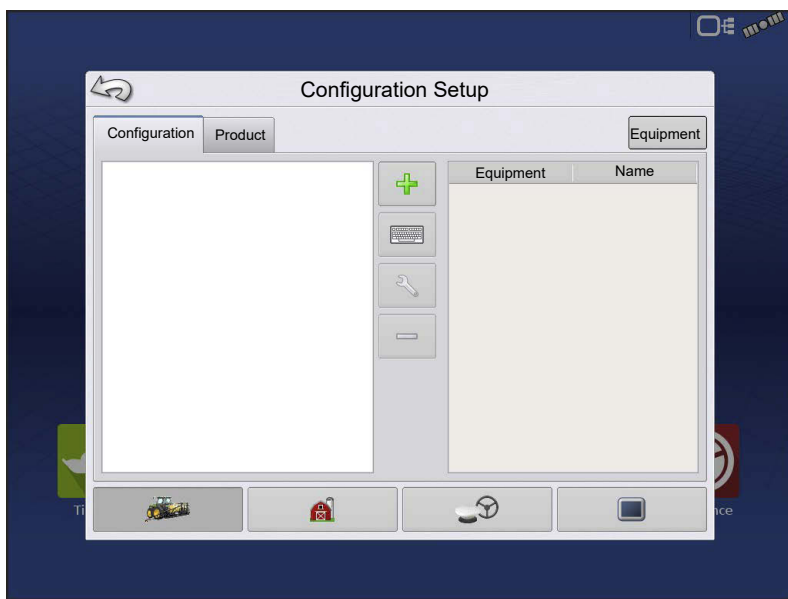

The Configuration tab is used to create, view and change configuration settings.

An operating configuration is a task-specific association of vehicle, implement, controller, and speed source that is saved for use over different seasons and on different displays.

•When finished, the new configuration appears in the list on the left side of the

screen.

- When highlighting the configuration, the equipment in the configuration is listed in the box on the right side of the screen.



**NOTE!:** Information regarding configurations for specific operations is given in each operations feature user guide.

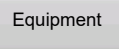

**WARNING!:** When a configuration is removed, all data logged with that configuration will also be removed! However, all log files will remain in memory until exported to the USB drive.

-  Press to add, edit, or remove information for a specific vehicle, implement or controller.

## Vehicle Offsets

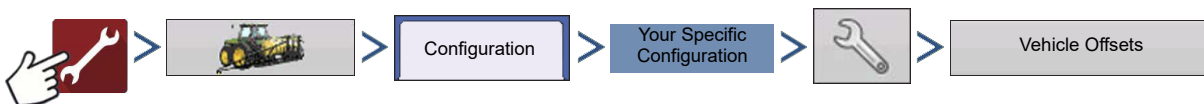

Vehicle offsets can be entered during configuration setup or later using configuration settings.

Vehicle offsets define where the machine's rear axle and hitch is in relation to the GPS antenna.

These settings are used for accurate mapping and AutoSwath™.



When the process of setting up a vehicle is completed, vehicle offsets can be re-configured later.

The vehicle offsets settings consist of two tabs: the Antenna tab and the Hitch tab.



**NOTE!:** Accuracy when measuring for a specific setting is essential to ensure proper machine performance.

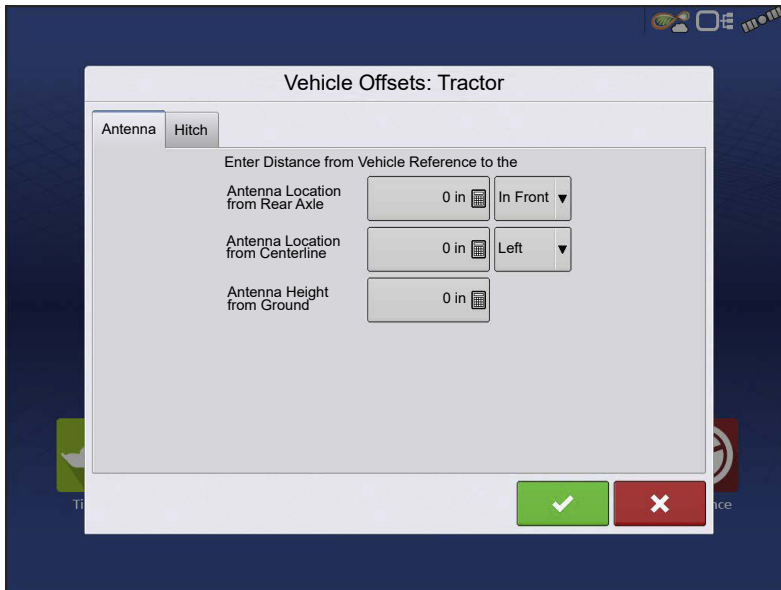

Antenna Offsets tab

At the Antenna tab, enter the distance from locations on the vehicle to the antenna.

- Measure and enter the horizontal distance from the rear axle to the position of the GPS antenna.

Select IN FRONT or BEHIND to indicate the position of the antenna in relation to the rear axle.

- Measure and enter the horizontal distance from the center line of the vehicle to the position of the GPS antenna.

Select LEFT or RIGHT to indicate the position from the vehicle center line.

- Measure and enter the vertical height of the antenna above the ground.

## Hitch Settings tab

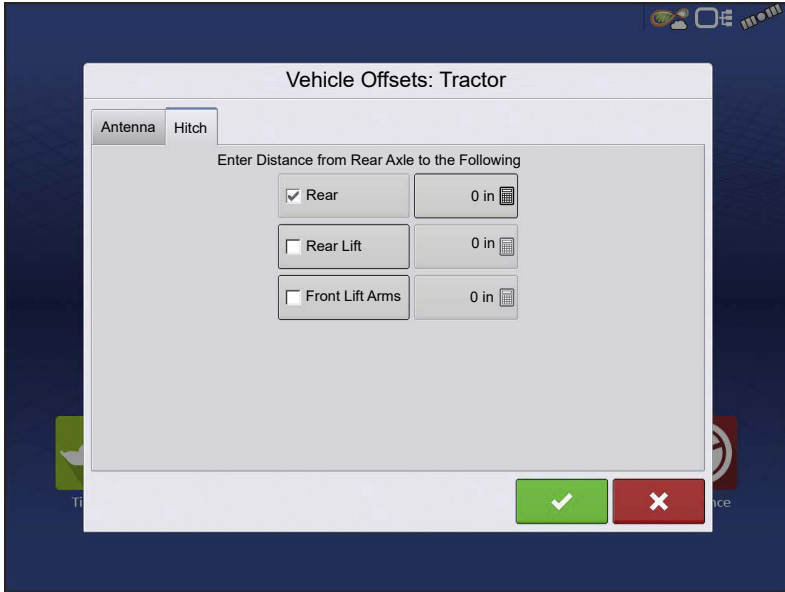

The Hitch tab is used to enter in the distance from three different mounting positions on the tractor to the rear axle.

Press  to enter these values in if using the hitch point.

 **NOTE!:** Accuracy when measuring for a specific setting is essential to ensure proper machine performance.

## Mount Tab Settings

The Mount tab will only be available when using a Self-Propelled sprayer.

Enter in the application location from the rear axle. Press  to enter in the distance and the drop-down box to select if it is in front or behind of the axle.

## Implement Offsets

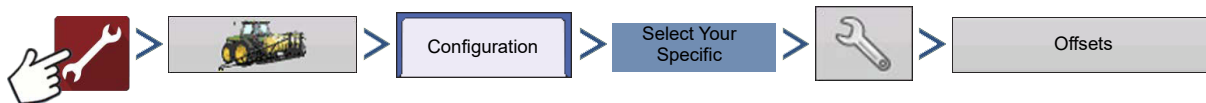

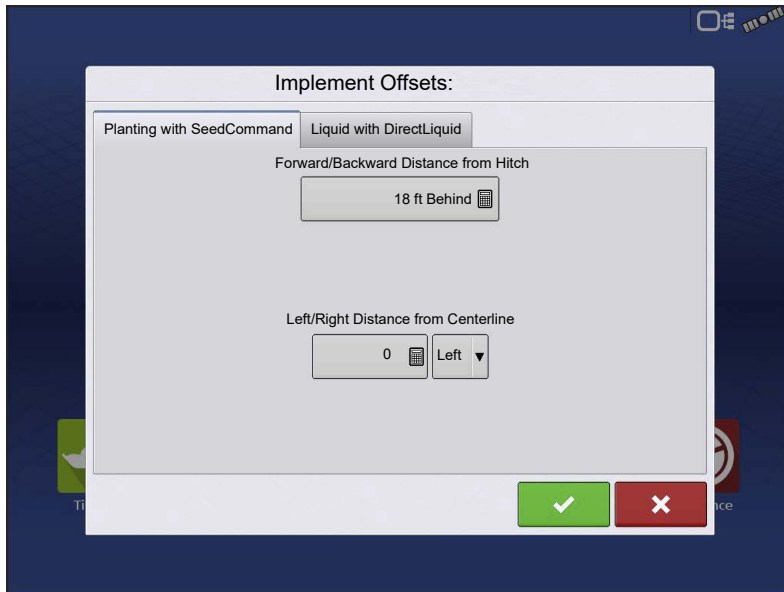

Implement offsets are used to accurately portray how equipment is setup and operating. An implement offset may be needed to account for incorrect guess rows and minimizing skip/overlap.

## Section Offsets



- Press the first  to enter the distance that the application point is located from the hitch point.

- Press the second  to enter the distance from the mid-point of the swath section to the machine's centerline. Select to the left/to the right to indicate the direction the swath section is located from the vehicle centerline.
- Press  when finished.
- Multiple tabs will appear across the top if different controller types are used in the configuration.

## Speed Input Settings

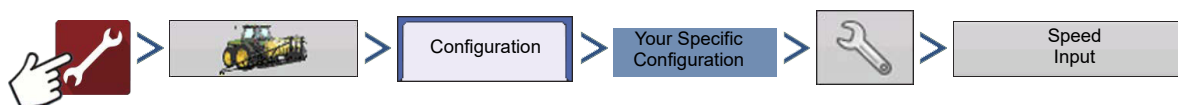

This will show speed in the upper blue bar of the Map screen, when operating.

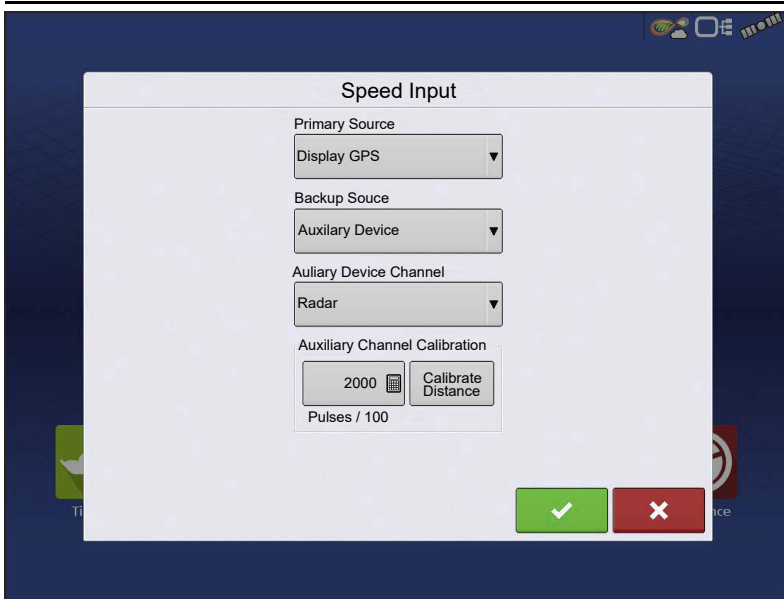

Choices for Primary Source include:

- Display GPS
- Auxiliary Device
- Manual Speed

**Primary vs Secondary Speed Source**—By default the display will use the primary speed source when operating on the Map screen. If for some reason the primary speed source is unavailable it will revert to the secondary speed source.

**Display GPS**—The display will use the GPS receiver attached to the display via Serial or CAN (Intellislope®) as the speed source.

**Auxiliary Device**—An auxiliary device can be either radar or wheel speed (combine). When using an auxiliary device be sure to calibrate it for an accurate speed input.

**Manual Speed**—In the event GPS speed or an auxiliary device is unavailable the display can be set to manual speed.

## Product tab



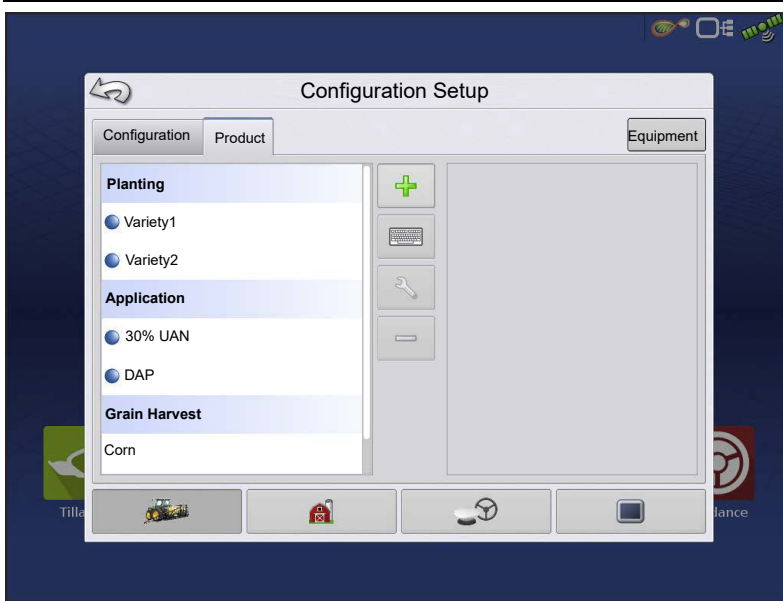

The Product tab is used to perform the following tasks:

- Add or import Planting products.
- Add or import Application products.
- Add product template (such as a tank mix, or a dry blend of multiple products).
- Add or import Harvest products.

## Add button



Press to add or import a product. At the following screen, choose a Product Option: Add Product, Import Product, or Add Product Mix (if in Application). From here, an on-screen wizard continues through each step of the setup process.

- When finished, the new product appears in the Product tab.
- When product is highlighted, information about the product appears on the right side of the screen.
- Specific planting and application product information can be viewed in those respective user guides.



**ATTENTION!:** When a product is removed, all regions using that product will also be removed.

## Management Setup



**Management button**—from this screen the operator can access Grower/Farm/Field, Season, User, and Businesses

tabs. **Grower/Farm/Field tab**



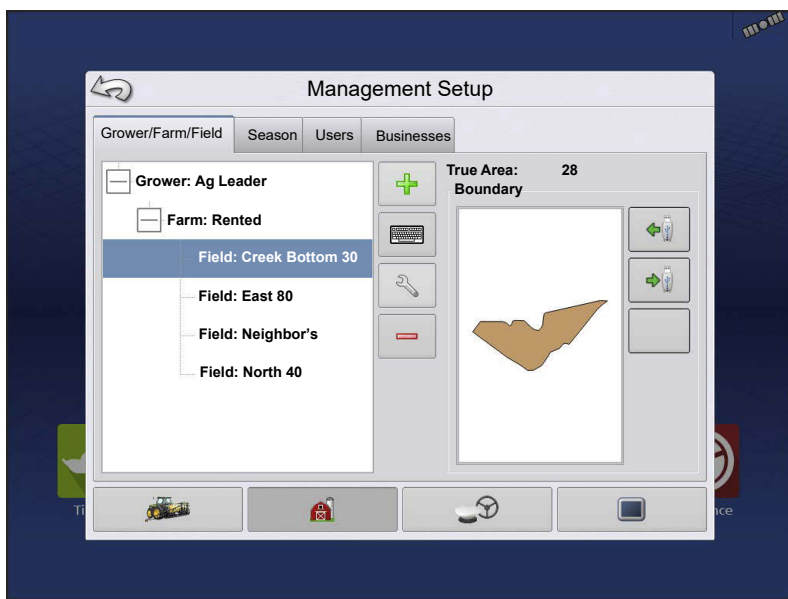

## Grower

The Grower refers to the business or person that the system is in operation for. Contact information can also be entered for each Grower. The Grower information will be passed into mapping software for automatic Grower setup within desktop software. Personal Information entered at this screen can be added or edited at any time.

## Farm and Field

In the display, farms are subdivided into fields. Field names can be associated with a particular Farm or Grower. If the display will be used for multiple Growers, enter each Grower business name and associate the Farm and Field names with the correct Grower when the fields are set up within the system.



To edit field specific information, press settings button after highlighting the field name.

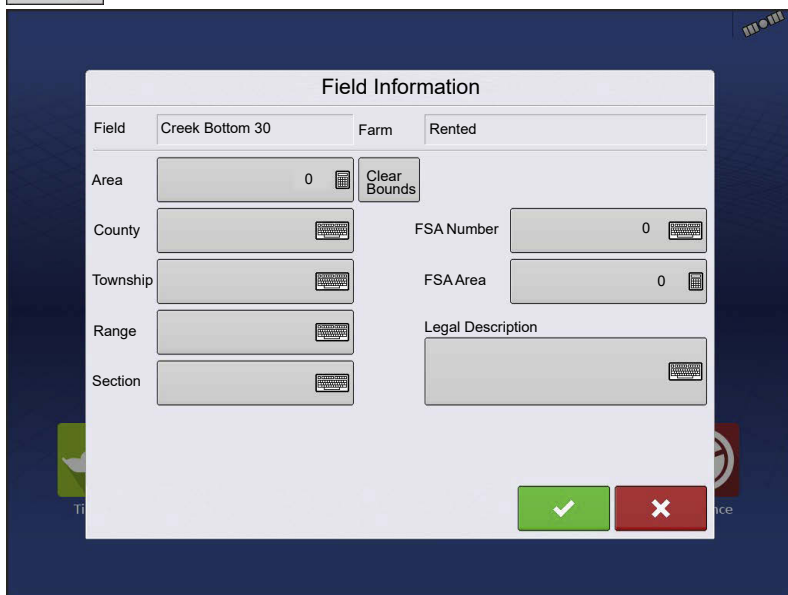

The Field Information screen opens, showing the name of that field in the Title Bar. Field name information that can be added or edited by pressing  including Farm, County, Township, Range, Section Number, Area, FSA Number, FSA Area and Legal Description.

**Area**—shown in the total acres (hectares) of the field. Used to calculate area remaining in field.

**Clear Bounds button**—press to center the map on the current GPS position.

The Clear Bounds feature is particularly useful with flyer points or a logged point outside the mappable range of current location.

## Importing and Exporting Field Boundaries

Boundaries can be created with the display or imported from desktop GIS software. Any boundary files present in the display can also be exported for use in desktop mapping software.

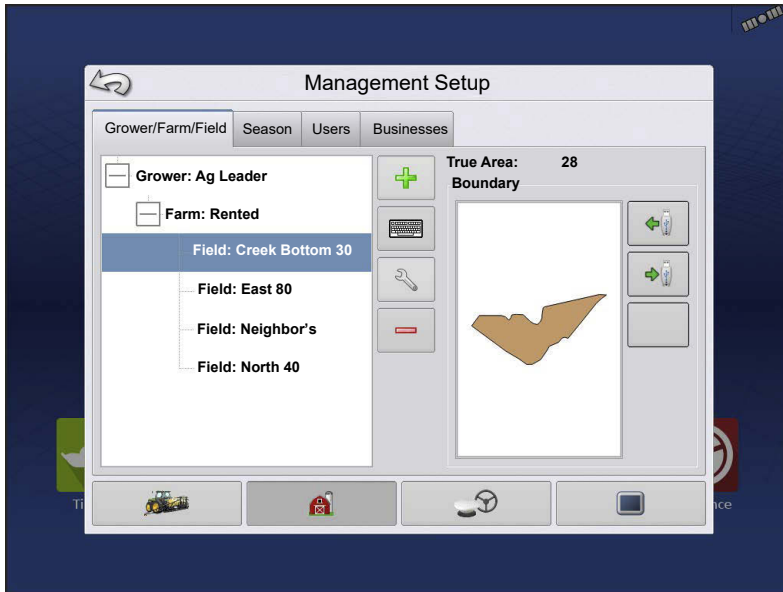

USB Import button

To import a boundary from the USB drive, first go to the Setup Field tab, highlight the correct field in the Farm/Field list and press the USB Import button.

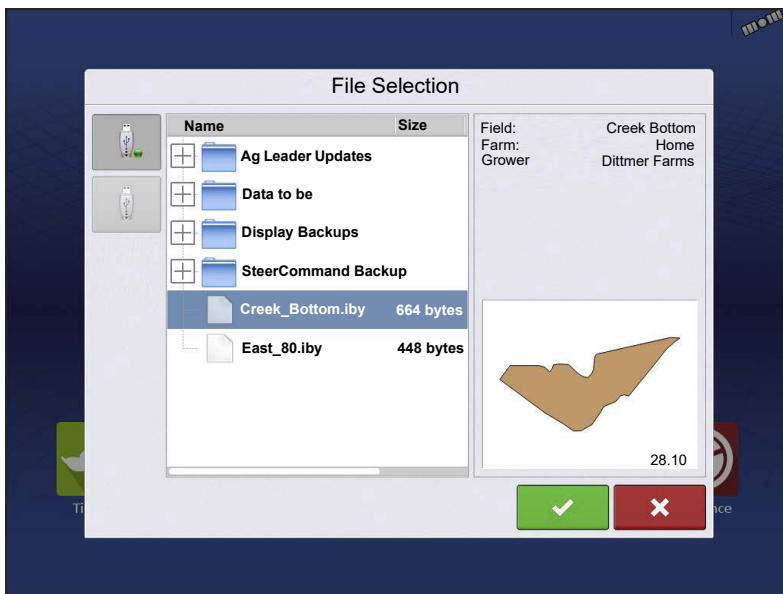

The File Selection screen appears. Highlight the desired file to import.

Press  to complete the import process.

Operator can import/export all fields and boundaries at once with an .AGSETUP file.

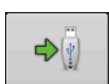

USB Export button

To export a boundary to the USB drive, highlight the correct field in the Farm/Field list and press the USB Export button. At the File Selection screen, highlight the desired field to

---

export. A screen will appear indicating that the boundary was successfully exported. Press

 return to the field setup screen.

## Season tab



A Season is defined as the calendar year that the crop will be harvested. A Season has a start and an end date. Creating a Season and setting it to active is required prior to the system logging any data.

The seasons are displayed in lists, with the active season displayed in bold face type. All new data is logged to the active season; therefore a Season must be set as active before any new data can be logged to it.

If a user would like to remove logged data from the display they can delete a season from the display. Before deleting a Season make sure that all logged data has been properly archived within management software or AgFiniti® Mobile.

Deleting a season while using DisplayCast will delete the season on all connected displays.

## Users tab

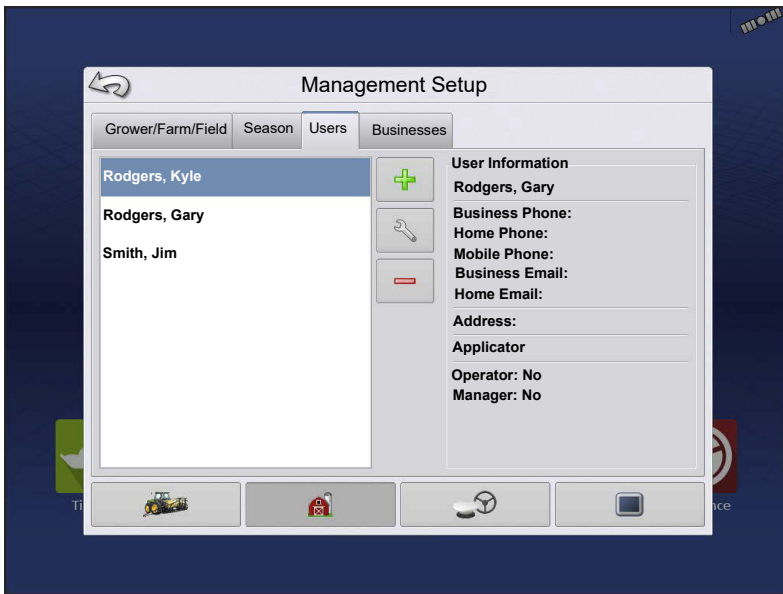



User tab allows user to add, modify, or delete users from the display.



## Add a User



1. Enter first name and/or last name (have to enter a first or last name, recommend entering both).
2. Enter applicator license (optional). Press  to continue.
3. Select Operator or Manager (can select either, none, or both). Press  to continue.
4. Enter and verify password (optional).
  - Locks the displays ability to load/change operating configurations, access setup and USB, if Manager has a password set
  - Leaves display unsecured unless each manager sets a password
  - No restriction for password format (can be any combination of letters, numbers, and special characters)
  - Case sensitive
5. Press  to accept.

## Edit User Profile

The screenshot shows a mobile application interface for editing a user profile. The title is 'Edit User'. There are four tabs: 'General', 'Phone/Email', 'Address', and 'Permissions'. The 'Phone/Email' tab is selected. Below the tabs are five input fields, each with a keyboard icon on the right: 'Home Phone', 'Mobile Phone', 'Business Phone', 'Home Email', and 'Business Email'. At the bottom of the form, there are two buttons: a green button with a white checkmark and a red button with a white 'X'.

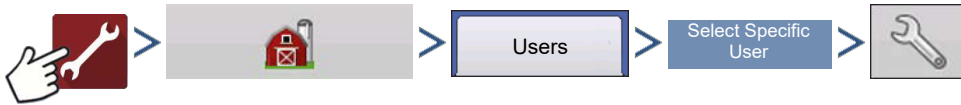

“Edit User” screen allows user to edit information originally entered when profile was added. Edit button also allows access to more phone, email, and address information.

**General tab**

- First and Last Name
- Set and Clear Password
- Applicator License
- Memo

**Phone/Email tab**

- Home Phone
- Mobile Phone
- Business Phone
- Home Email
- Business Email

**Address tab**

- Address
- Extended Address
- City/Locality
- State/Province
- Country
- Postal Code

## Permissions tab

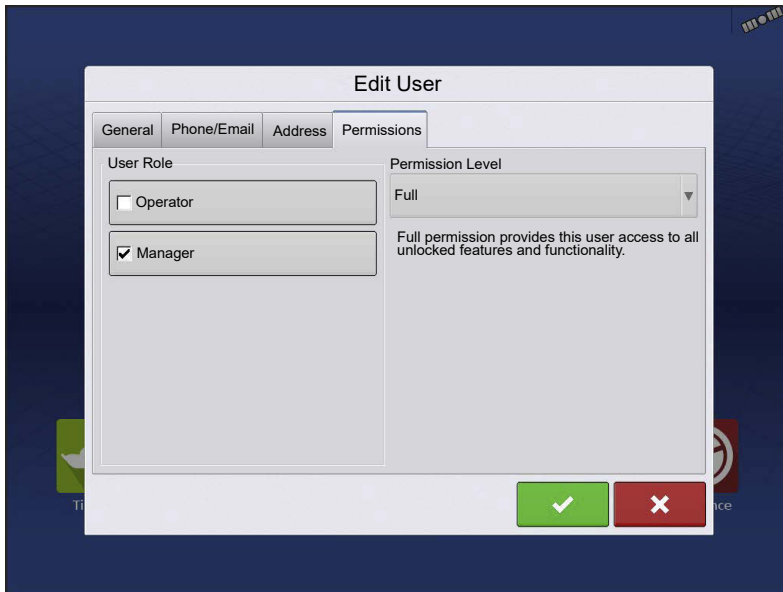

This is an optional function that defines what access the user will have in the display. Users are defined as Operator or Manager (can select either, none, or both).

## Operators

- Have full or limited access
- No access to USB or Setup options, unless also set as a Manager
- Can import from USB from Map screen (RX, patterns, boundaries)
- Manager sets up privileges

## Managers

- Full access to the display settings and functions
- Only user that can change the selected configuration
- Ability to log out of the display

System can be set up with operators only. Passwords are not used when set up this way.

## Permission Level For Operators

**Full Permission**—Provides full access to features and functionality on the map and home screen. A user, set only as an Operator, cannot select a different configuration and cannot access data transfer or setup, when a manager is setup in the display.

**Basic Permission**—No access to:

- Summary screen
- Legend tab on Map screen

- Marks tab on Map screen
- Boundary tab on Map screen

Limits Guidance options to:

- Creating & loading Straight AB or SmartPath patterns
- Nudge
- Remark A
- Save or reset guidance line

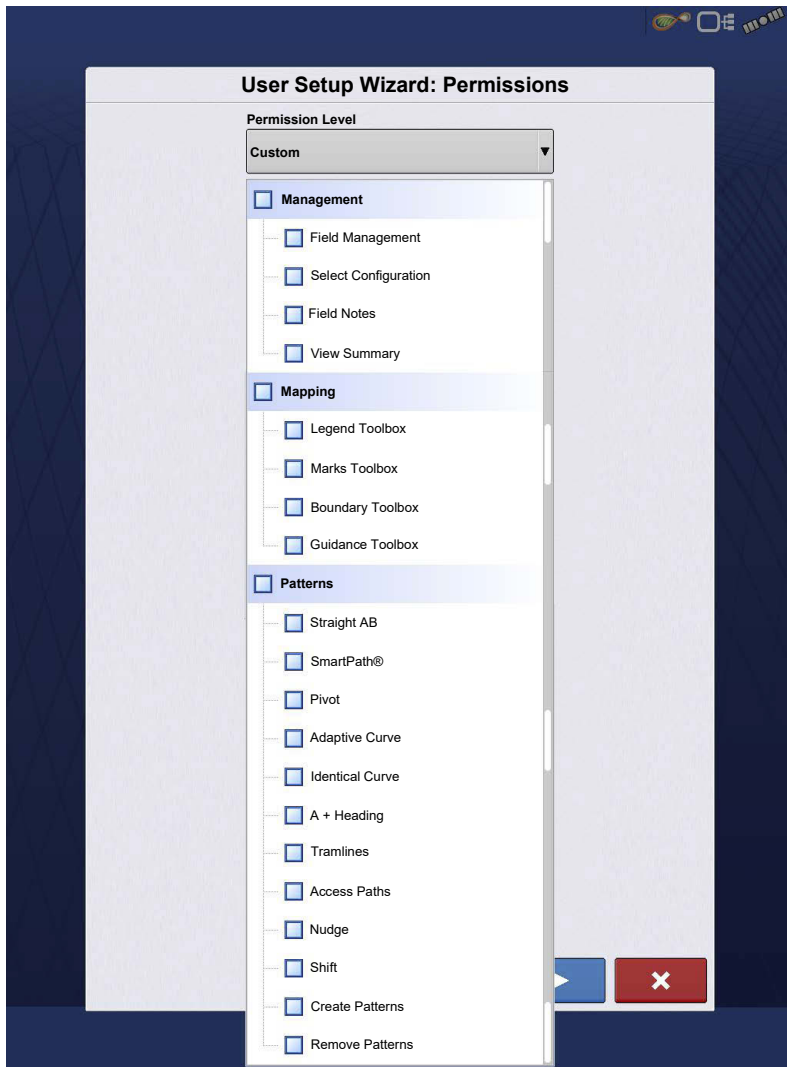

**Custom Permission**—Can allow or deny the following options:

- Management screen
- Pan/Zoom controls
- Legend Toolbox
- Marks Toolbox
- Boundary Toolbox
- Guidance Toolbox
- Minimize Toolbox
- Each individual guidance pattern
- Ability to remove guidance pattern

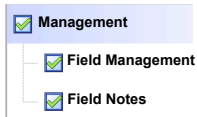
	<p>Display uses Traditional mode when Field Management is checked. Events using the Traditional mode are tied to the Grower/Farm/Field structure.</p>
---	---

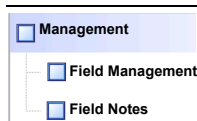
	<p>Display uses Events Only mode when Field management is unchecked.</p>
---	--



The Home and Map screen will appear different depending on the assigned user permissions.

### Basic Permissions - Home screen

- Summary screen locked
- Setup and Data Transfer are locked (as indicated by a padlock icon on those buttons)

- Operator Change - Option to continue or start new operation when operators change

### Full Permissions - Home screen

- Summary screen button is accessible.
- Setup and Data Transfer are locked.
- A manager can access these buttons by pressing the button and inputting their password.
- Configuration is locked when field operation is started.

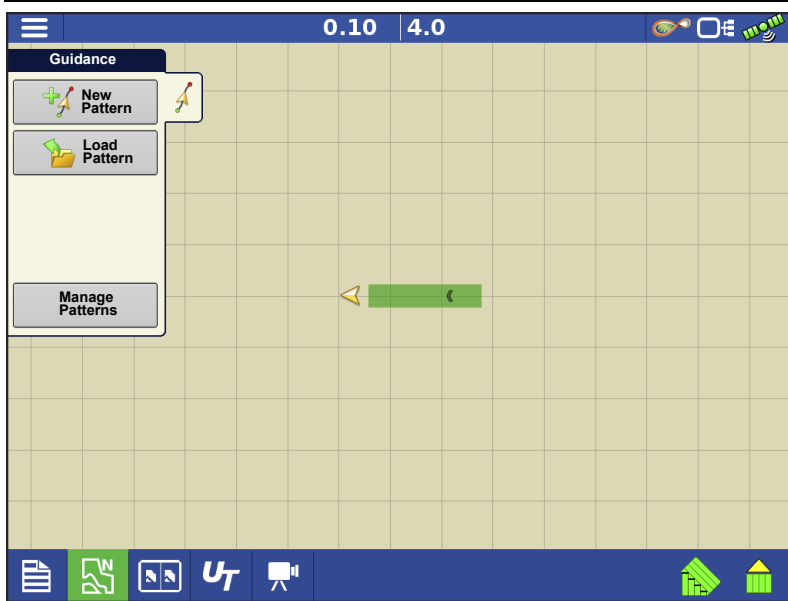

- Guidance and Legend tab
- Create guidance lines
- Straight AB
- SmartPath®
- Nudge
- Guidance setup

### Accessing Setup Menus



A. Press Setup (wrench) button.

B. Select Manager from drop-down menu. Press .

C. Enter password. Press .

Now have complete access to the setup menus:

- Configurations Settings
- Grower management
- GPS settings
- Display settings

Do not have to be a Manager to create certain objects

- Grower
- Farm
- Field
- Product (can't change units)

### Accessing Data Transfer

#### Data Transfer



A. Select Manager from drop-down menu. Press .

B. Enter password. Press .

Now have complete access to the USB functions:

- Networking
- AgFiniti Login
- Import/export
- AgSetup files
- Export data
- Check for Upgrades
- Advanced options
- Advanced Options with USB
- Ability to create/restore backups from USB
- Options for exporting log files
- Export by grower
- Export data at shutdown
- Export all log files

## **Forgotten Passwords**

When a Manager forgets his password he won't be able to access Setup. Tech Support will be able to generate a password based on the serial number and firmware of the monitor.

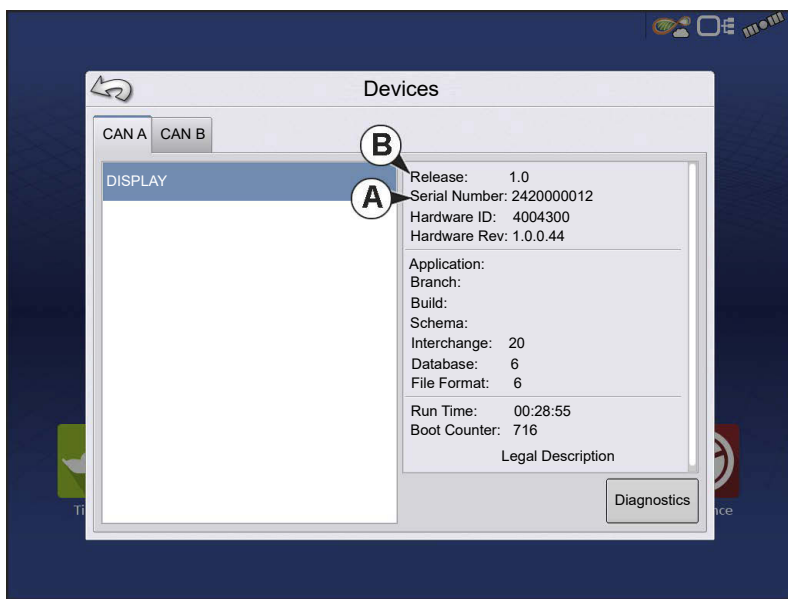

Password generator will require the following information:

A. Display serial number

B. Release—Firmware version

Only needed when a Manager forgets their password and works within the display until firmware is upgraded.

### How will Tech Support identify if the person calling in is a Manager or not?

They will ask the caller, “Are you a Manager in the display?” If the customer answers yes, Tech Support will generate the password. If the customer answers no, Tech Support will require a Manager to authorize the display to be unlocked.

### What if a customer doesn’t want to risk forgetting passwords and generating new ones?

A display does not need to be locked with a password. The display can be operated without passwords. Operators can also be setup with limited or customized access without passwords.

#### Tips

- Managers keep a record of all passwords set in the display.
- Operators write down personal password.
- To avoid Operators obtaining unwanted access to a display, instruct them to call a Manager for help with passwords before Tech Support.

### Businesses tab



The businesses are displayed in lists, with the active business displayed in bold face type. All new data is logged to the active business; therefore a business must be set as active before logging any new data to it.



## Display Setup



The Display screen contains the following tabs:



- **General tab** — Displays settings related to time, date, display screen settings, operating units, enabling video input, and ISOBUS settings.
- **Display tab** — Setting up and make any needed edits to the owner personal information.
- **Features tab** — Lists unlocks for display.
- **AgFiniti tab** — Access AgFiniti account settings and options. [See AgFiniti® on page 59.](#)
- **Advanced tab** — Includes information related to log files and system backups.

### Features tab



### Unlocking Features

The Features tab is used to enter unlock codes. Unlock codes are unique to the serial number of each display and the feature registration number. Supply these numbers to dealer when purchasing unlock codes.

Press  to enter the unlock code and press  to enable the

feature.  **NOTE!**: Once a feature is

unlocked, that feature remains with that display and cannot be transferred to another.

---

## Advanced tab



The tab allows to specify:



- Settings for copying log files.
- Specify Key Switch Standby settings.
- View and manually upgrade module firmware.
- Create and restore backup files.



**WARNING!:** The Export Diagnostic Files, Advanced Parameters, Copy Debug Files, Clear Debug Files and Service Mode functionality on the Advanced tab is reserved for use by the manufacturer. DO NOT change any of these settings without specific instruction from the manufacturer.

### Key Switch Standby

This setting allows the display to remain powered up after the vehicle power has been shut down. The display will switch into standby mode and will appear to be shut off; however the power light will change to an amber color. Pressing the touch-screen while it is in standby mode will immediately turn the screen back on again. For this feature to work, the display must be connected to switched power.

Use  /  to specify a length of time for display to remain powered up in standby mode after the vehicle power has been shut down.



**NOTE!:** When the time specified in Key Switch Standby is nearly expired, then the amber-colored power light will flash on and off immediately preceding shutdown. Touch the display to restart the Key Switch Standby countdown.

### About button

Displays product licensing information and copyright information.

### Memory

Adjusts information stored in the display's internal memory.

- Create Backup.

Press to create a backup file of all configuration settings, products, and Grower-Farm-Field Management data structure on the USB drive. Backup files are stored using the .ibk3 file format.

- Restore Backup.

Press to restore a backup file from the external data drive to the internal memory of the display.

- Clear Internal Memory.

Press this button to clear the internal memory of the display. The system will present a warning dialogue box and ask if a backup file should be created prior to clearing the memory.



**WARNING!** Once the system's internal memory is cleared, this information is deleted and cannot be restored unless a backup has been made.

## View Module Firmware

Displays the Module Firmware Management screen, which is a list of all firmware modules and firmware versions that are available for the display.



**NOTE!** The Module Firmware Management list includes module firmware that may not be running.

- Upgrade

Update module firmware with firmware stored on the display.

- Upgrade from USB

Upgrades an individual module directly from the USB.

- Suppress Upgrade Alarms

Display will no longer prompt to automatically upgrade modules.

## Remove Patterns



**NOTE!** Pressing this button permanently erases all guidance patterns from the display's memory.

## General Tab



## Demo Mode



Demo Mode is used for training and demonstration purposes. Demo Mode gives the ability to show the display in a fully functioning environment without the need for a CAN or GPS simulator. Demo mode is a completely separate run environment from the normally operating mode. This keeps all customer data separate to remove the risk of data getting deleted.

Any data that is added, removed or changed while in demo mode will be deleted upon power cycling the display and returning to a normal operating state.

## How Demo Mode Works

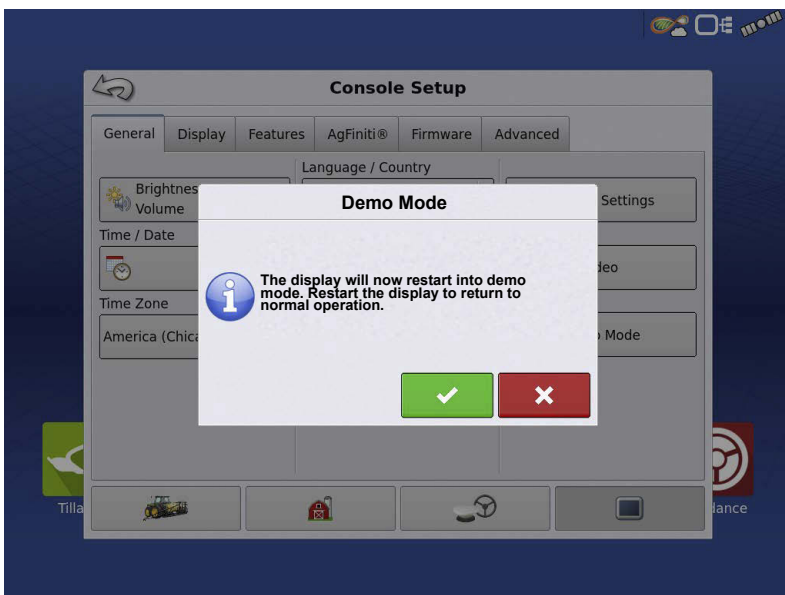

1. Pressing the Demo Mode button will trigger a request to restart the display. Once restarted, the display will automatically begin an event in demo mode.

2. The event that automatically starts will be a 12 row planter running clutch control, Ag Leader seed tube monitoring, and three variety split logging.

3. The event will continually run on the mapping screen. Users can interact with the menus and legends exactly like they would during a live operation.

4. The demo will continue to run until the field is completed. Once the field is completed the display will sit for 2 minutes then restart demo mode over again repeating the loop.
5. Coverage Logging can be manually toggled on an off by pressing the Master Switch icon in the lower right corner of the screen. With coverage logging off using can leave the mapping screen and go into all menus and setup screens normally. If they would like to continue the demo event it can be done by following the prompts via the Planting Operation Wizard.

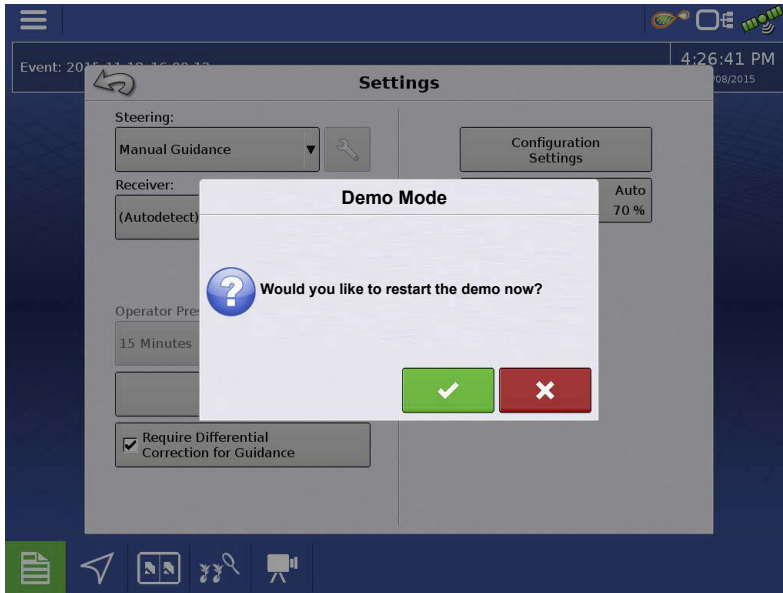

6. Any time the display is not active on the mapping screen and left untouched for 2 minutes the display will prompt for demo mode to restart. If the prompt is not accepted within 30 seconds demo mode will automatically restart.

7. To return to normal operation, restart the display. **Any data created in demo mode is automatically deleted on display restart.**

## ISOBUS Settings

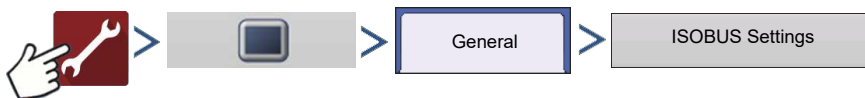

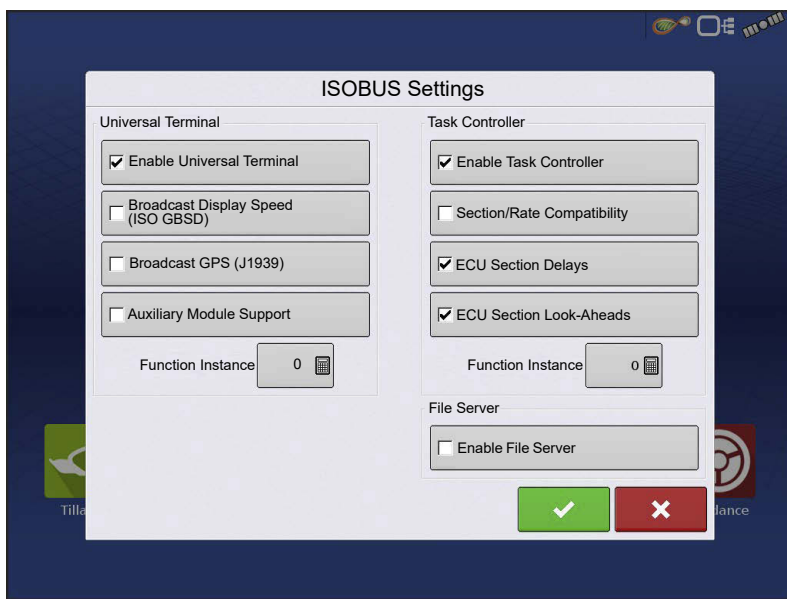

## Universal Terminal

The display is compatible with the ISO 11783 (ISOBUS) Universal Terminal Standard. This enables support of many ISOBUS compliant implements on the display. Universal Terminal functionality enables the compliant implement's user interface to be viewed and controlled on the display.

Once Universal Terminal has been enabled, it will appear in the task bar. Toggle between the Universal Terminal screen and other display functions by pressing the UT button.

## Task Controller

The InCommand™ displays have the ability to use ISOBUS Task Controller on compatible ECU's. This allows the InCommand display to control rate and sections of an ISOBUS ECU using Ag Leader's proprietary interface. A properly setup display configuration is required for this to work.

## ISO Load and Go

With a properly setup ISO ECU, ISO Load and Go streamlines the configuration building process for task controller ECU configurations. The Load and Go feature automatically builds a controller during the configuration building process based on the ECU device description. For this to work it requires the device description to have proper sections, section offsets, and product type setup on the ECU.



**NOTE!** Maximum of 144 sections supported with 3rd party ECU's.

## File Server

Diagnostic logging for the troubleshooting of Hardi Sprayers.

## Common Terminology

**ISOBUS Working Set**—One or more ISOBUS modules that control an implement's functionality.

**Working Set Master (WSM)**—Main module responsible for coordinating all communication between the UT and the Working Set including loading of the Object Pool to the UT screen.

**Object Pool**—The graphic image presented to the user on the UT display. The Object Pool is sent to the UT by the ISOBUS module.



**ATTENTION!:** Before operating an ISOBUS implement with the display, read the operator's manual provided by the implement's manufacturer and follow all safety information provided in the manual. When this display is used with an ISOBUS implement, the information and functions on the display are provided by the implement ECU and are the responsibility of the implement manufacturer.

**Broadcast Display Speed (ISO GBSD)**—Checking this box allows speed source currently being utilized by the display to be broadcast over the ISOBUS to the implement ECU.

**Broadcast GPS (J1939)**—Checking this box allows GPS data being supplied by the GPS receiver to be broadcast over the ISOBUS to the implement ECU.

**Auxiliary Module Support**—Checking this box allows the Ag Leader Auxiliary Input Module or Smart Switchbox, to be used with ISOBUS ECUs that support AUX-N auxiliary functions.

**Universal Terminal Functional Instance**—Always set to 0 except when there are multiple UTs on the ISOBUS. Use to change instance. Reboot Display.

**Section/Rate Compatibility**—This setting determines how often the Display target rate message is sent to the ISOBUS ECU.

- When unchecked, the target rate message is only sent when it is changed on the display.
- When checked, the target rate message is sent at regular intervals. This is a non standard ISOBUS setting. Leave this setting off unless ISOBUS ECU has an issue with the target rate resetting to zero on its own.

**ECU Section Delays**—Determines the manner in which mapping delays are handled with ISOBUS ECUs.

- 
- When checked (default), mapping delays are determined by ISOBUS ECU and the “look-ahead” interval stored in the Ag Leader display. Leave this checked when using DirectCommand Gen2 ISO Liquid.
  - When unchecked, mapping delays are determined by the “look-ahead” interval stored in the Ag Leader display. This method is thought of as industry standard and is used by various manufacturers. Leave this unchecked when on ground AutoSwath performance is correct but display mapping is showing gaps/overlaps.



**NOTE!:** Enabling/disabling this setting does not effect on-ground section performance.

**Enable File Server**—Enables Hardi Sprayer specific diagnostic logging for troubleshooting purposes.

**Task Controller Function Instance**—Always set to 0 except when there are multiple TCs on the ISOBUS. Use to change instance. Reboot Display.

**ECU Section Look-Aheads**—Determines how look-aheads are used for AutoSwath with ISOBUS ECU.

- When checked (default), the display will use look-ahead settings from the ISOBUS ECU.
- When unchecked, the display will use look-ahead settings that are entered and stored in the displays Automatic Swath Control settings.



**NOTE!:** Enabling/disabling this setting will effect on-ground section performance.



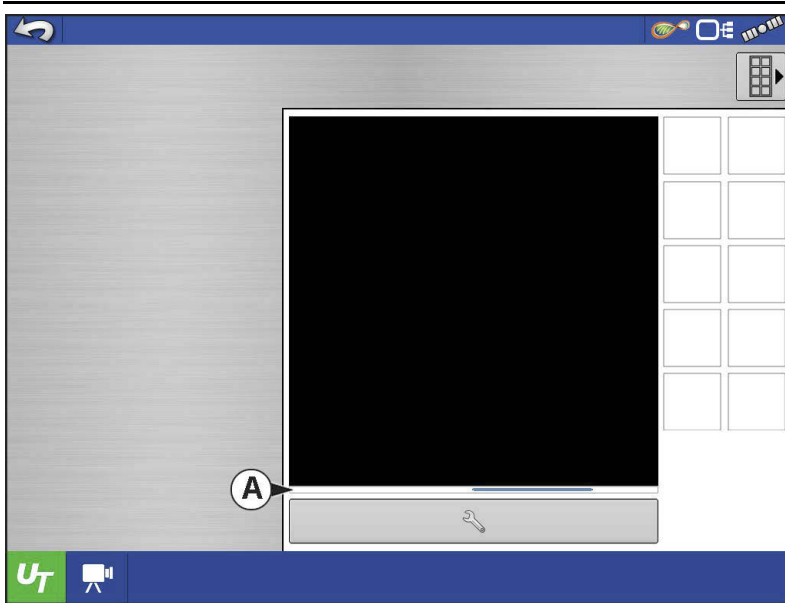

When an ISOBUS compliant implement is connected to the display for the first time, the implement WSM sends its graphic interface, called the Object Pool, to the display. The Status bar (A) appears while Object Pools are being loaded. This process might take several minutes depending on the number of Object Pools being loaded. Once loaded, object pools are stored in the display memory.

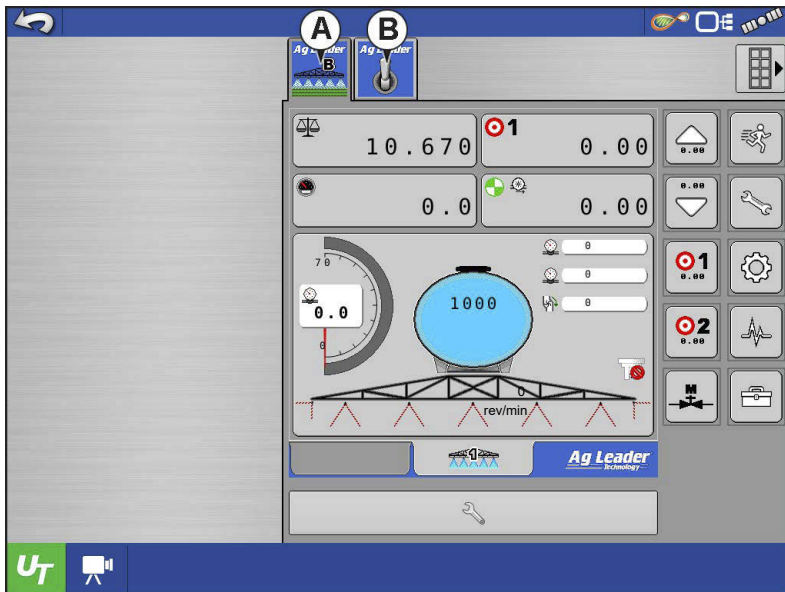

If there are multiple ISOBUS implements connected, press the UT button to toggle between Working Sets.

The Working Sets can also be accessed by pressing tabs (A) or (B) individually.



Advance through multiple screens of buttons. This button remains hidden unless more than 10 buttons are present.



Opens the Universal Terminal Settings screen.

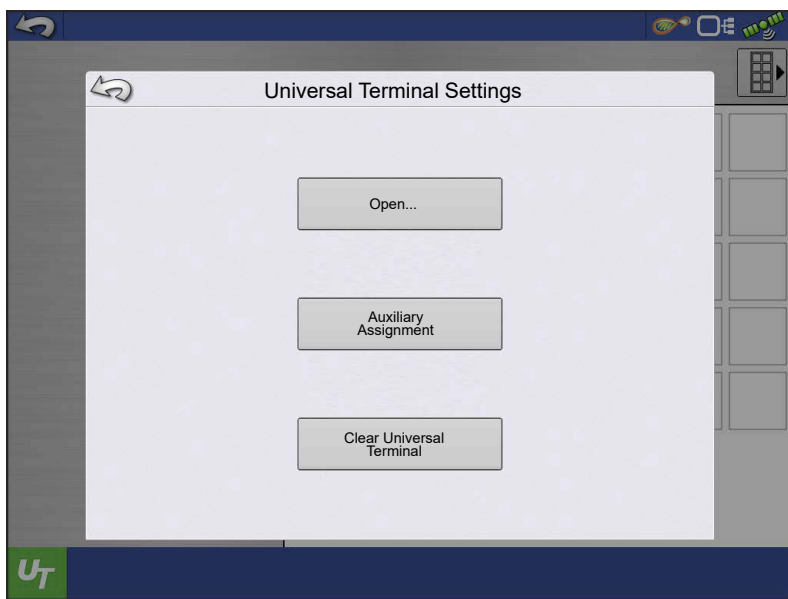

**Auxiliary Assignment**—assign implement functions to ISO compatible inputs.

**Clear Universal Terminal**—Allows operator to clear the Object Pools sent to the display from the implement WSM.

After the object pools have been cleared, the next time the implement is connected the object pools will be transferred from the implements WSM to the display again. When this button is pressed, a warning dialogue box appears with the following message:

“All Universal Terminal interfaces saved in the display will be cleared. Do you want to continue?”

### Auxiliary Assignment

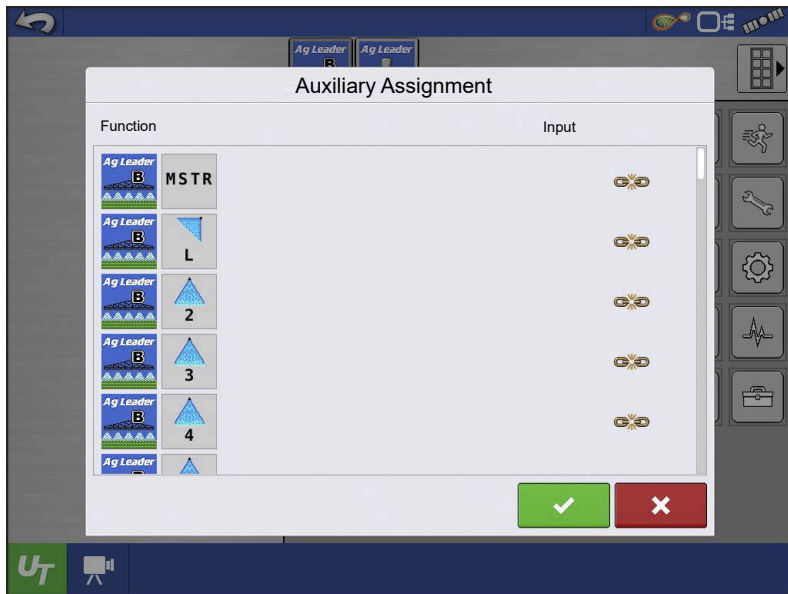

Auxiliary Assignment

Assign implement functions to ISO compatible inputs.

The number of functions and inputs shown on the Auxiliary Map screens will vary depending on the implement and input devices connected to the display.



## UT Alarms and Trouble Codes

If the display receives an active trouble code, the Universal Terminal Alarm will appear in the Status bar at the top of the screen.

When an alarm is activated on the UT, the display will indicate the alarm by flashing “Universal Terminal Alarm” in the status bar.

Alarms are acknowledged and cleared by pressing .

This button is only present when a Universal Terminal alarm has been activated.

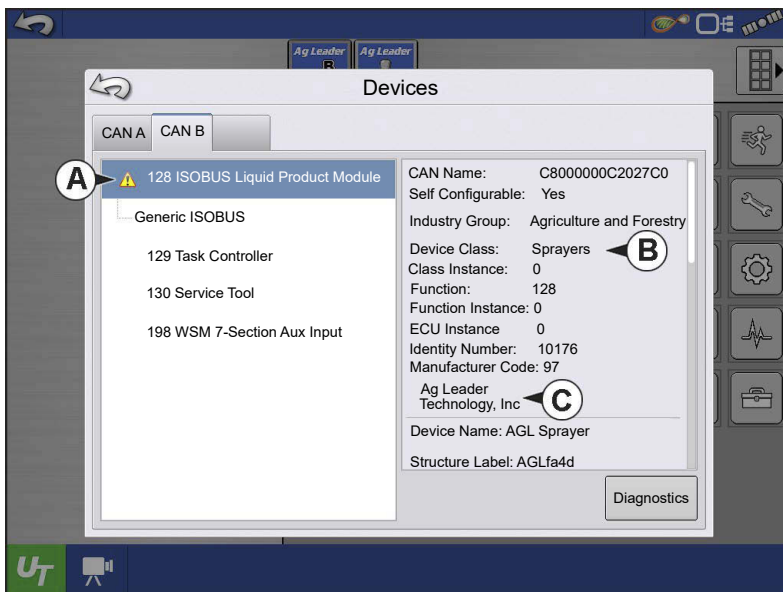

The Devices screen displays the following information:

A. Caution icon indicates module has active trouble codes (DTCs)

B. Device Class

C. ECU Serial Number

D. UT Manufacturer, name and code

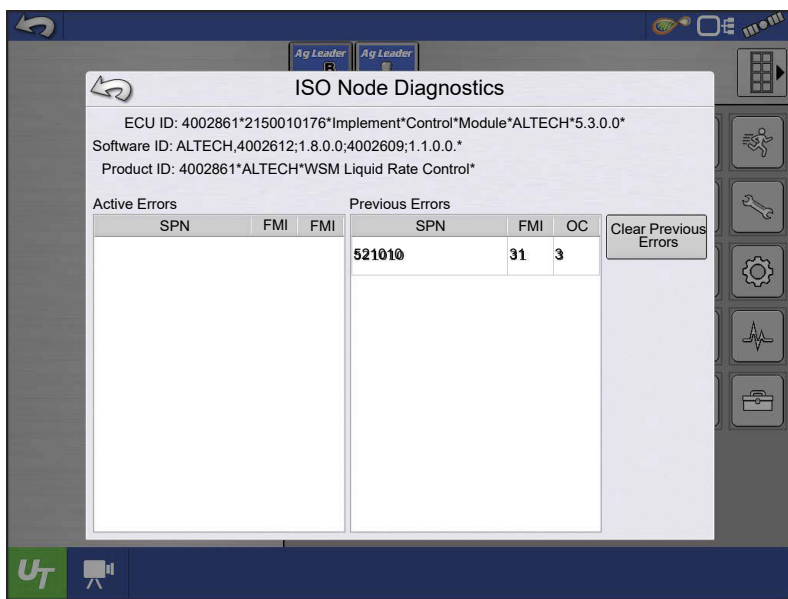

Pressing the Diagnostics button on the Devices screen brings up the ISO Node Diagnostics screen which shows the following information.

**SPN**— “Suspect Parameter Number” = Error Number

**FMI**—“Fault Mode Indicator” = Error State.

**OC**—“Occurrence Count”

**DTC**—Diagnostic Trouble Code

This is a combination of the SPN and the FMI (for example 522102.12).

Cross-reference DTC in equipment manufacturer’s operator manual for description of error.

## Video

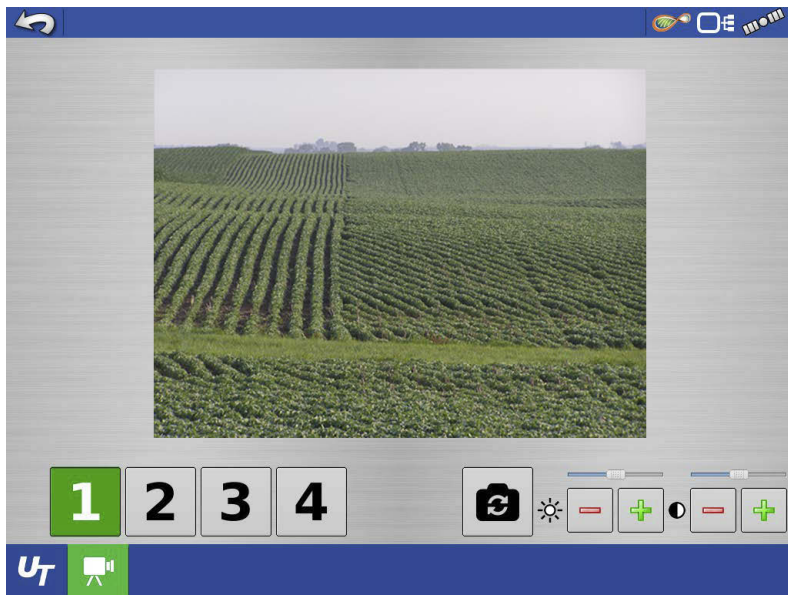

Video button. Camera is available from the Home or Map screen. Press video button and the Video screen appears.



Mirror Video Input



Brightness Adjust



Contrast Adjust



**NOTE!:** Video is only available when enabled in the Display Setup menu.

- Camera Number Selection

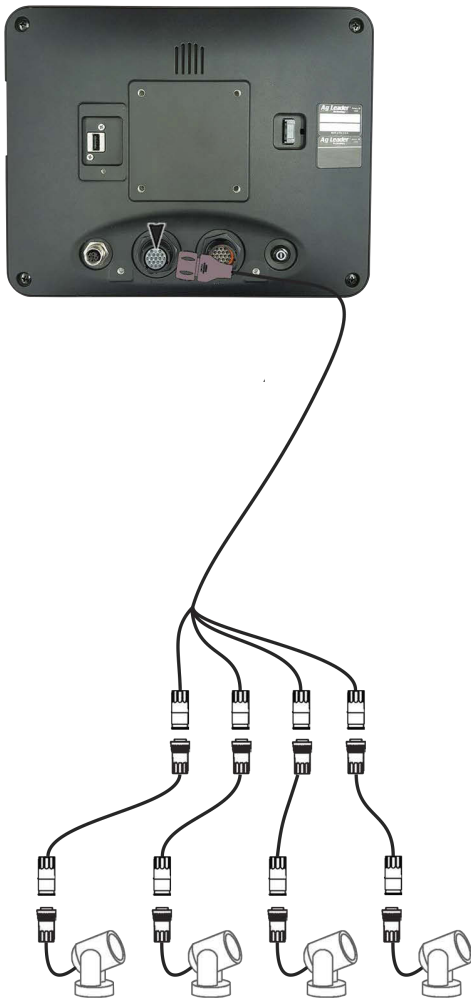

The display can receive input from up to four video cameras. Press the numbered buttons to switch views between video cameras.

**i** **NOTE!**: Adjust the brightness and contrast of each input individually.

**Camera Harness**—A camera cable, sold separately, will plug into the aux port on the back of the display.



## Data Transfer screen

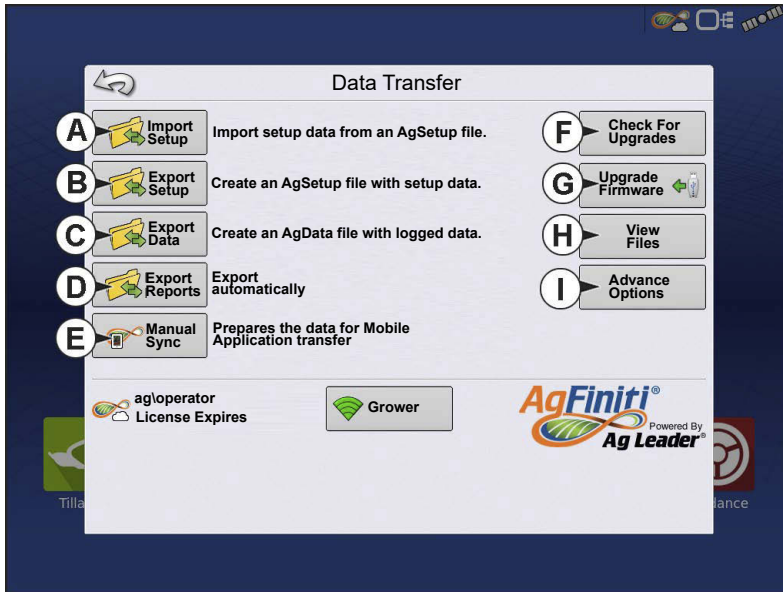

**A. Import Setup**

**B. Export Setup**

**C. Export Data**

**D. Export Reports**

**E. Manual Sync**

**F. Check For Upgrades**

**G. Upgrade Firmware**

**H. View Files**

**I. Advanced Options**

- Create Backup
- Restore Backup
- Export by Grower
- Export at Shutdown
- Export all Logs

- 
- Export ISO XML

## **.AGSETUP Files**

Used to transfer setup information from display to display or from SMS™ and display

- Allows full synchronization of the following file formats:
  - Management Data (Growers, Farms, Fields, Seasons, Operators)
  - Products and Product Mixes
  - Boundaries
  - Guidance Patterns
  - Marker Sets and Markers
  - Configurations



**NOTE!:** Do not use the IBK to “clone” a display. Use AGSETUP or make a new setup.

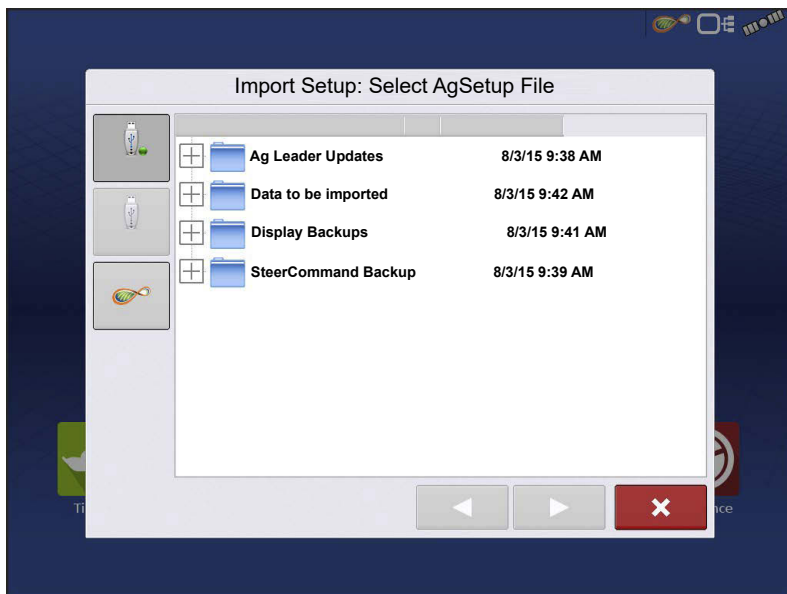

### **Import .AGSETUP file from AgFiniti® or USB**

The File Selection screen opens. Use the scroll bar to find the file to import.

### **Export .AGSETUP file to AgFiniti or USB**

Use to transfer setup information from display to display or from SMS and display.



---

## **.AGDATA files**

Used to transfer data to management software from the display via AgFiniti or USB.

- Includes all the necessary data to fully archive in SMS
- Includes recorded operation data
- Products Used
- Boundaries
- Equipment Used
- Marks Logged
- Guidance Patterns
- Flexible export options
- Able to export by Grower

## **Exporting Logged Data**

After a field operation is completed, data can be exported to USB or AgFiniti. This can be accomplished by pressing the “Export Data” button within the [Data Transfer screen on page 51](#) and selecting the export location. Under the advanced options menu within the Data Transfer screen, users can also choose to export by grower/event and/or at display shut down.

- Pressing the “Export Data” button will trigger all data to be exported based on the last time the export button was pressed. After data has been exported to the external device, it is still retained within the displays memory.
- If previously exported data needs to be retrieved from the display it can be accomplished by pressing the “Export All Logs” button under advanced options within Data Transfer. Export all logs will export all logged data stored on the display.
- Data on the InCommand™ displays is not automatically deleted after any export operation. Users have the ability to delete old seasons, ([See “Season tab” on page 28](#)) which includes the logged data, to free up memory on the display.

## **Export .AGDATA file**

### **ISO XML export**

This function enables the export of data files in the TASKDATA.XML format.

---

## Supported operations

- Multi-Product and Multi Channel liquid and Granular operations
- Rate Logged with ISO Modules
- Flow Logged with Proprietary Modules
- Single channel/drive planter
  - Planter sections are mapped
- Site Verification
- Summary totals

## Enable ISO XML Export

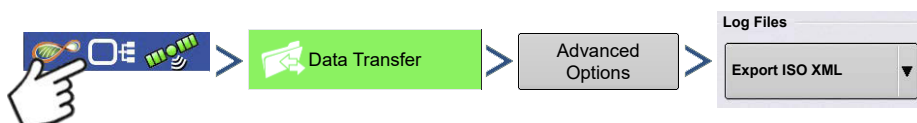

## Display Backups

A display backup creates an exact clone of a display's current contents. This includes all management information, configurations, and logged data on the display. Backups should be taken at regular intervals through an operating season to minimize any data loss in the event of a display failure. Display backups can only be used on a like display with the same or newer firmware than the backup was created on. Example: a display backup from an InCommand 800 cannot be installed on an InCommand 1200 display or vice versa. When a display backup is restored onto a display it will overwrite all existing data on that display. Users moving data between multiple displays should use an .agsetup file instead of a backup file to accomplish this task. .Agsetup files have the ability to merge and add data to a secondary display so there will be no risk of data loss.

### ibk3 files

- System backup file. Backup files are written to USB drive.

## Create Backup File (USB drive Only)

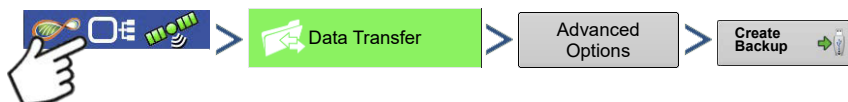

Use to create backup file.

Ag Leader recommends backing up the display regularly to prevent/minimize data loss in the event of a display failure.

## Restore Backup File

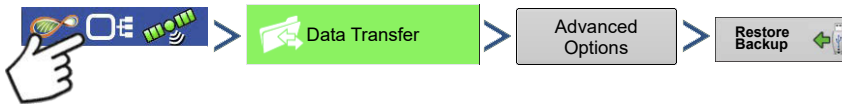

## Upgrade Firmware.fw3

- See [“Upgrading Display Firmware” on page 16](#) for details on updating display firmware.



**WARNING!** Do not disconnect display power when the upgrade is taking place.

## Export Reports

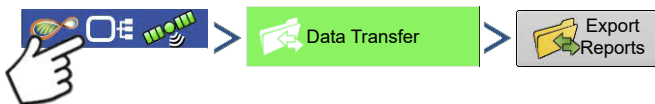

Exports Reports saved on internal memory.

## Manual Sync

The Manual Sync button is used when logged data needs exported to AgFiniti Mobile when the display operator is still in the middle of the field operation. Pressing the Manual sync button will prepare data from the active event to be sent to be AgFiniti Mobile. The display operator must disable logging on the Mapping screen to accomplish this. When the AgFiniti Mobile app is opened, new data from closed or suspended events is automatically checked for and transfers at regular intervals. The Manual Sync button only needs to be used if the customer needs data from the active event and does not want to suspend or close it.



---

## AgFiniti®

AgFiniti is Ag Leader's platform to provide users the ability to quickly and easily transfer data, view their display remotely, and take logged data when leaving the vehicle.

### AgFiniti Mobile

AgFiniti Mobile is Ag Leader's native iOS®<sup>1</sup> app. It provides the ability to take maps and summary information from the cab and SMS™ Desktop Software then access it on an iPad®<sup>2</sup> anywhere. The app allows for a wireless connection to the display, reducing the need for a modem or Wi-Fi hotspot in the cab and providing a simple, direct connection to access data. AgFiniti Mobile also allows for multiple display connections, allowing for operations with multiple displays to have their logged data all in one iPad. Data imported into Mobile will remain there until removed by the user or the app is uninstalled. See [AgFiniti Mobile on page 62](#).

### AgFiniti Cloud

AgFiniti provides functionality via its website <https://www.agleader.com/farm-management/agfiniti/> and the AgFiniti mobile app. AgFiniti cloud can be accessed using a computer, tablet, or phone with a web browser or with either an Apple or Android device (using the AgFiniti app which is separate from AgFiniti Mobile). The AgFiniti cloud gives you the ability to view your account information, previously exported data from SMS and even more when an AgFiniti Essentials license is added to your account.

AgFiniti provides the following features at no additional cost:

- **File Transfer**—Wireless transfer of data between the InCommand™ display and Ag Finiti Cloud. Export prescriptions and management information generated in SMS and access them in the cab using AgFiniti Essentials. This requires an active internet connection.
- **Background Imagery** – when signed in, satellite background images will appear on the display screen
- **Remote Support** – provide the ability to share the screen with an AgFiniti Essentials user
- **Automatic Display Update** – when signed in, users will be prompted to update display firmware when a new version is detected

---

1.iOS® is a registered trademark of Apple Inc.

2.iPad® is a registered trademark of Apple Inc.

---

## AgFiniti Essentials

AgFiniti Essentials provides a number of features, listed below, that allow additional functionality when using the AgFiniti cloud and Mobile app .AgFiniti Essentials requires the purchase of an annual license.

- **LiveMaps**—Live maps provide AgFiniti Mobile users the ability to view field operation data logged in real-time from anywhere, not just in the cab. All that is required is updated InCommand and AgFiniti Essentials license.
- **Cloud Processing**—.AGDATA and supported 3rd party data files in the AgFiniti cloud are processed so that maps can be viewed online from any iOS, Android™<sup>3</sup>, or Windows®<sup>4</sup> device.
- **Cloud Sync**—AgFiniti cloud and AgFiniti Mobile will sync data once connected. Logged data is accessible via iPad or on the web without having to go to each display. This also allows SMS data such as soil types, soil sampling sites, and third party display information (such as planting or harvesting data from a non-Ag Leader display) to be shown on the iPad as well.
- **DisplayCast®**
- **Remote Support**—AgFiniti Remote Support grants the ability to remotely view a display from the AgFiniti website. This allows dealers, managers, or support to efficiently help the user when troubleshooting a problem or setting up display(s). See [Remote Support on page 79](#).
- **3rd party and API Connections** – connect with other 3rd party clouds to sync data to/from AgFiniti Cloud.



**NOTE!:** Account viewing the display must have an active Agfiniti Essentials License but the display being viewed does not.

---

3.Android™ is a trademark of Google Inc.

4.Windows® is a registered trademark of Microsoft Corporation

---

## AgFiniti Mobile Connection Types

### Display Access Point Mode

This connection type turns the InCommand display into a wireless access point that all compatible iPads can connect to. When using this connection type, every time an iPad is within range of the InCommand display, AgFiniti Mobile will automatically download new data while the app is running.

See [Display Access Point Connection Type on page 59](#) for step by step instructions to make this connection type.

### WI-FI Network

#### Connection Scenarios

- Transferring information when both devices are connected to the same home/office Wi-Fi network
- A hotspot (such as a jetpack) device is used in the cab to provide internet

When both the InCommand display and iPad are connected to the same wireless network, for example a home Wi-Fi network, they will be able to recognize one another and transfer data in the same fashion as the other connection types. If a Wi-Fi connection already exists in the vehicle cab, this connection can be utilized.

See [Shared Wi-Fi Network Connection on page 83](#) for step by step instructions to make this connection type.

### Cellular iPad as Personal Hotspot

#### Connection scenarios

- Only Cellular iPads when InCommand is accessing AgFiniti cloud

Cellular based iPads have the ability to act as a personal hotspot. This allows InCommand to access AgFiniti and directly transfer information to AgFiniti Mobile, both through the iPad's cellular connection and Wi-Fi hotspot. This connection type would be used when needing to use AgFiniti cloud and AgFiniti Mobile at the same time. For example, downloading an .AGSETUP file (for prescriptions) from AgFiniti cloud for Remote Support.

### Display Access Point Connection Type

# InCommand Display

InCommand Display

1. With the Wi-Fi adaptor installed in the InCommand display, the AgFiniti symbol  will show in the top right corner of the display.

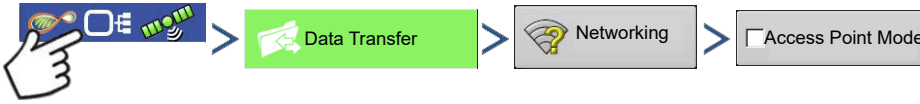

**i** **NOTE!:** If the login button is active, one of the other connection types may be utilized.

2. The display will prompt to be restarted. Press  to shut down and restart the display.
3. After the restart, the display will be broadcasting a Wi-Fi signal and can now be selected on the iPad.

## iPad

iPad

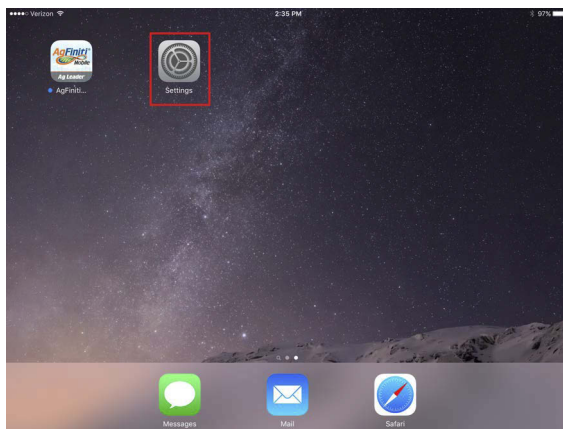

4. To connect to the InCommand Wi-Fi signal, go to the Settings app on the iPad.

## iPad

iPad

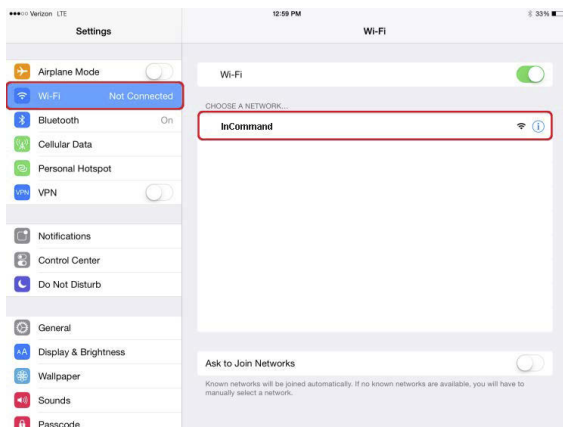

5. Select the “Wi-Fi” tab from the left side menu, ensure that “Wi-Fi” on the iPad has been enabled, then select the “InCommand” wireless network. This will connect the iPad and InCommand display together and ensure proper data transfer.

iPad



iPad

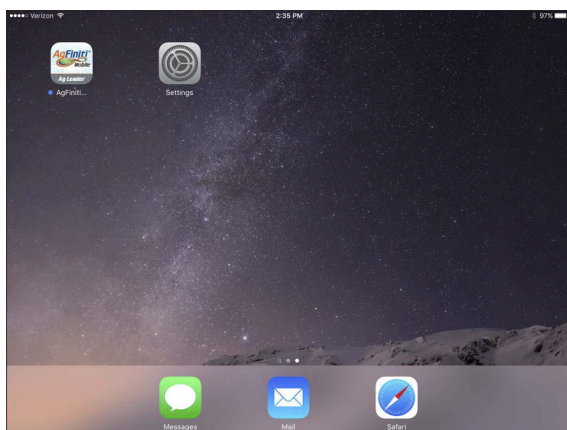

6. Once connected, proceed to open the AgFiniti Mobile app.



**NOTE!:** Download AgFiniti Mobile from the Apple® App store.

7. Once AgFiniti Mobile is open, it will automatically attempt to connect to the InCommand display.

InCommand Display

InCommand Display

8. You will be prompted on the InCommand display to allow connection.



**NOTE!:** Please wait up to a minute for this to occur. This will happen once per display.

9. After pressing , the iPad will begin accepting data from the display as it becomes available. This is indicated by the iPad symbol within the AgFiniti status indicator on the top right corner of the screen.



At this point, the InCommand display and iPad are connected and ready for data transfer. Closed or suspended events present on the InCommand display will now show up in the app.

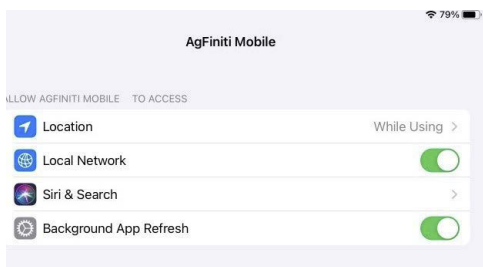

**NOTE!:** If user declines connection on the iPad, that setting will be saved and will need to be changed if future syncing is needed. This option can be found in the Settings App – AgFiniti – Local Network set to On

## AgFiniti Mobile



Once the connection between iPad and display has been established and access granted on the display, the connection indicator will turn from red (not connected) to blue (downloading) to green (connected). The number by each icon indicates items remaining to be downloaded/synced.



An additional icon that indicates maps are being built from the downloaded data will appear shortly after.

The data import process occurs automatically. Keep the app open until data finishes processing. After the import process completes, your maps/reports will be ready for reviewing.



**NOTE!:** AgFiniti Mobile will download data while running in the background but will need to be open in order to process information.

## Map Screen

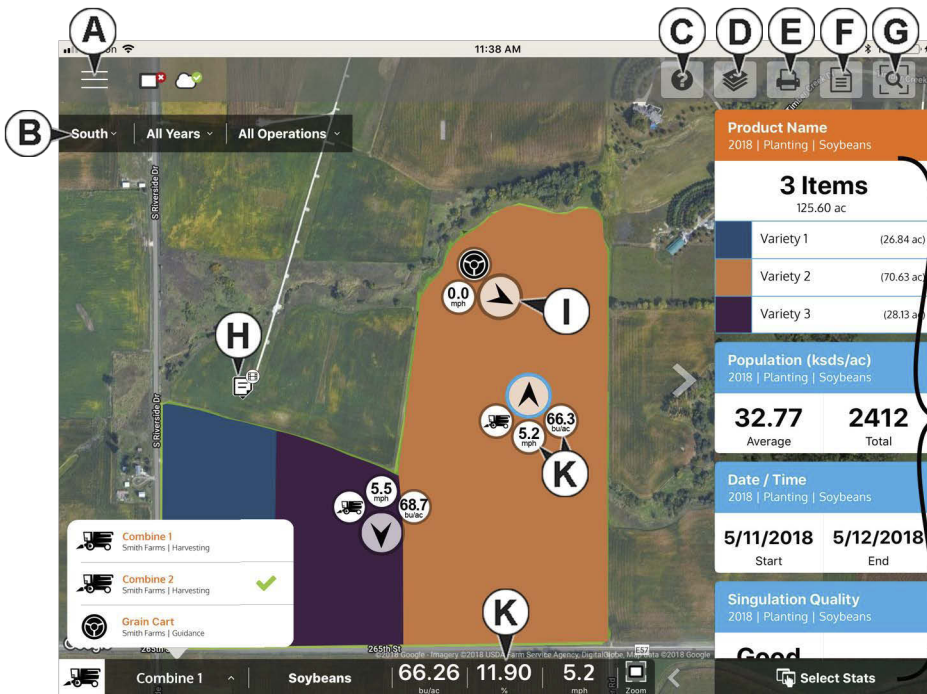

Tap any of these icons for additional sync details.

Once data is present, the layout shown is available:

- A.Menu ([page 71](#))
- B.Filters ([page 64](#))
- C.Help
- D.Area Query ([page 68](#))
- E.Print ([page 70](#))
- F.Summary Reports

([page 71](#))

G. Zoom Options ([page 68](#))

H. Notes ([page 69](#))

---

I. Display/Device Location ([page 76](#))

J. Stat Cards ([page 65](#))

K. Live Stats and Live Stat Bar ([page 76](#))



**NOTE!:** An active internet connection is required to see satellite imagery.

## Gestures

As with any iOS app, AgFiniti Mobile uses gestures. Navigate around the app, select items, and make various changes using gestures. The most common gestures are outlined below.



**Pinch In and Out**— Using two fingers, touch the screen and pinch in and out to adjust the zoom level of the map. If zoomed out enough field coins will begin to appear which can be selected to see data for other fields. If zooming in far enough, row by row level data will be shown on applicable fields.

**Tap to Zoom**—By tapping on the map the zoom level can be controlled. Quickly double tap with one finger to zoom in and single tap with two fingers together to zoom out.

**Tap**—Tap items in AgFiniti Mobile to select them. Tap on the map to set a manual location within the field and view its specific data in the Stat Cards

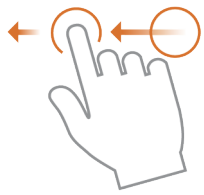

**Swipe**—Swipe finger to see additional menus on certain items.



**Pan**—Tap and hold finger on the screen to pan around the mapped data while maintaining the same zoom level.



**Tap and Hold** – Tap and hold on map to drop notes in AgFiniti Mobile.

## Filters

To choose different fields, years, or operations, use the Field/Operation Filters present in the upper left.

Creek Bottom All Seasons Planting

Product Name	2016   Planting   Corn
2 Items	
28.21 ac	
DK6169	(13.97 ac)
DK6186	(14.24 ac)

Date / Time	2016   Planting   Corn
2:30:49 PM 7:04:48 AM	
Start	End

Population (ksds/ac)	2016   Planting   Corn
30.45 859.0	
Average	Total

Singulation Quality	2016   Planting   Corn
Good More	
28.18 ac	

To choose different options, tap on one of the three filters and choose from the various options present. Use the search box to filter your fields/years/operations. This allows you to search for items like “soybeans” and just fields with soybean products will be shown. Choose All for both the season and operation filters to access all data present for a chosen year.



Use the tap gesture to make selections in the filter.



Use the pinch gesture to zoom the map in and out, and choose from other fields present in AgFiniti Mobile. If zoomed out far enough, field coins will appear, Tap a coin to see available fields.

## Stat Cards

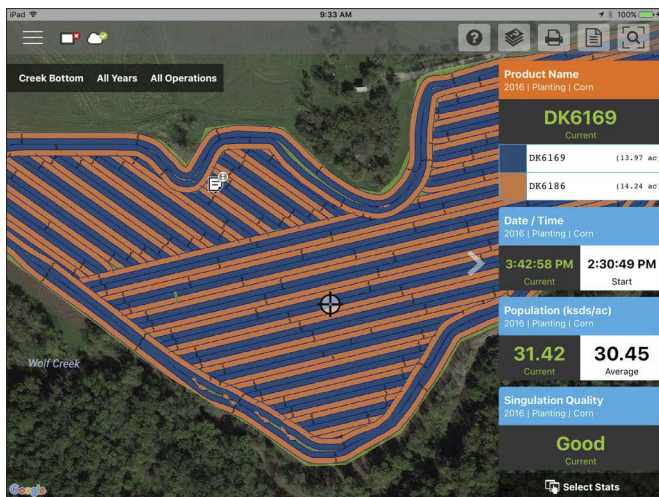

Along the right side of the app are Stat Cards. Stat Cards will contain information for data currently mapped. Tap on the Stat Card to view. The Stat Card that is currently mapped will appear orange in this list. The Stat Card will also indicate field average (if applicable), total and location specific values if a position is selected (as shown). Tap on a Stat Card's average or current box to view additional details for that

specific stat.



Use the tap gesture to select a location to view additional information on Stat Cards or select another stat.

Collapse the Stat Cards by tapping on arrow present next to the Stat Cards and expand it out by tapping on the same arrow again.

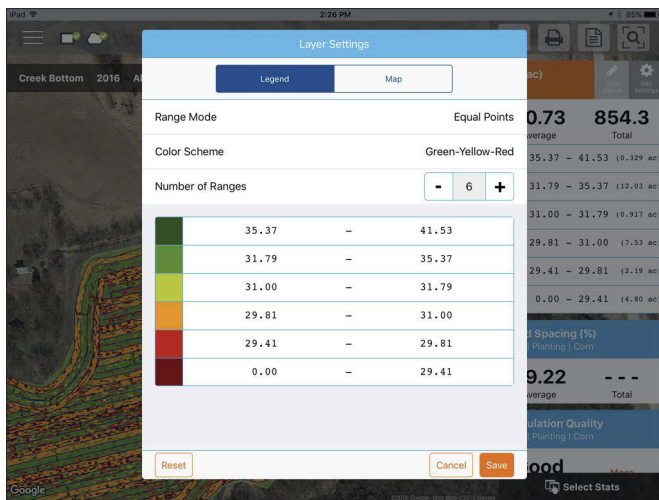

Edit the legend or map present by swiping the Stat Card title to access the stat options. This will display two options, Edit Source and Edit Settings.

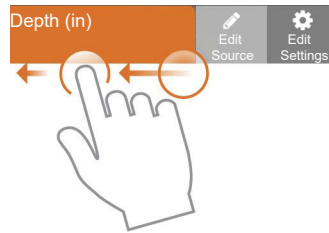

Edit Source will allow selection of different years, operations, or events—for example switching between two years of yield data for the same field or showing information about a field that had been replanted.

Edit Settings to change the map and legend settings. Mode, number of ranges and the color scheme can all be adjusted here. Adjust various map settings such as the transparency, map type and drawing settings by tapping on the Map button at the top.

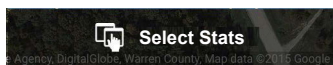

Back on the map screen, tap on the Select Stats option to choose which Stat Cards are displayed.

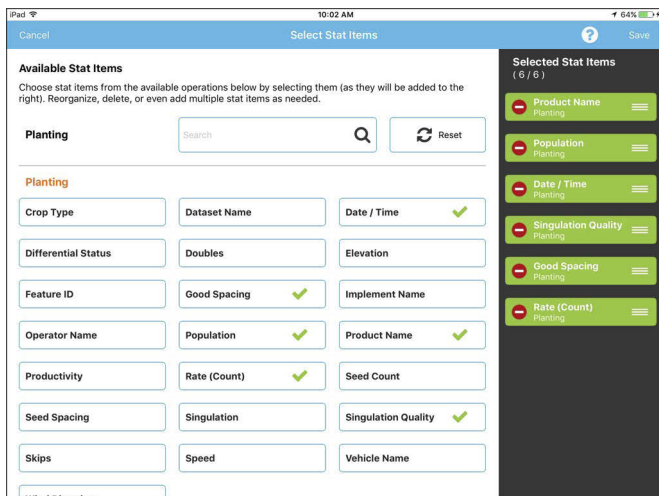

Tap on a Stat Card to add to the list on the right. To remove a Stat Card, tap on the red circle.



**NOTE!:** When changing or resetting Stat Cards, AgFiniti Mobile will do so by filtered operations. For example, if Planting is selected in the field filter and stats are changed, it will do so only for Planting.



Use the tap gesture to make selections.

## Labels

Labels can be turned on for sparsely populated base maps (soil sampling) and contoured maps (yield maps) and make it easier to view information for the mapped field.

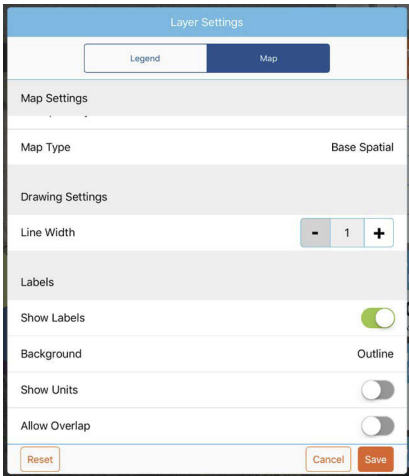

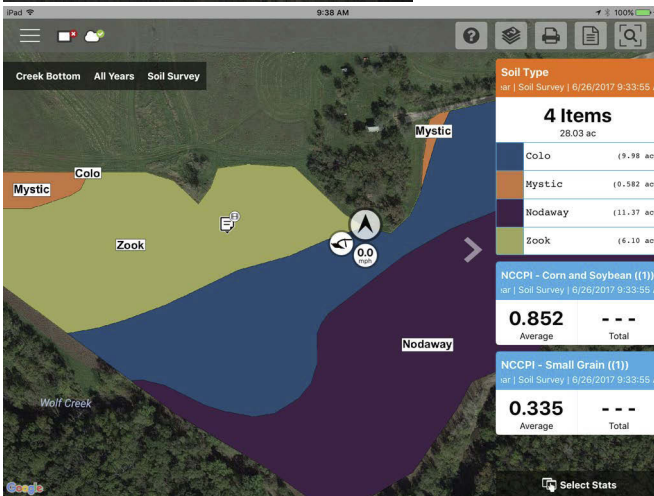

To turn on labels, swipe left on the desired stat card and tap Edit Settings. Then tap the Map option, toggle labels on and make any needed changes to their appearance.



**NOTE!:** Make sure to set the map type to Contour in order to view labels on yield and other more dense datasets.

## Area Query



Area Queries give you the ability to select a specific area within in the mapped field and gather more information for that selection. To begin, tap on the area query icon  and draw the desired area. Once the query is drawn, the stat cards will display both average and total for the selected area and entire field. Tap on the stat card for additional details. To clear a query, tap on the cancel icon in the lower left. 

 **NOTE!:** Active area queries can be printed and shared with others. Just tap the print button while a query is active to either print or share.

## Zoom Options



Use tap to make a selection.



Access the various zoom options present in the app.



**Zoom Current**—Sets the zoom level to your GPS location, keeps you centered on the map, and the stat cards will update as you move across the data for your field. Location access must be granted to the app.





**Zoom Field**—Sets the zoom level to the currently mapped field shown in the Field/Seasons/Operations filter.



**Zoom Device**—Sets the zoom level to all devices logged in AgFiniti (with GPS location and Essentials license). Only devices within 60 miles from the AgFiniti Mobile location will be displayed when Zoom Devices is pressed. Vehicles farther away can be viewed but user must manually pan the map to find them.



**Zoom World**—Sets the zoom level to show ALL fields in the app.

## Add Note

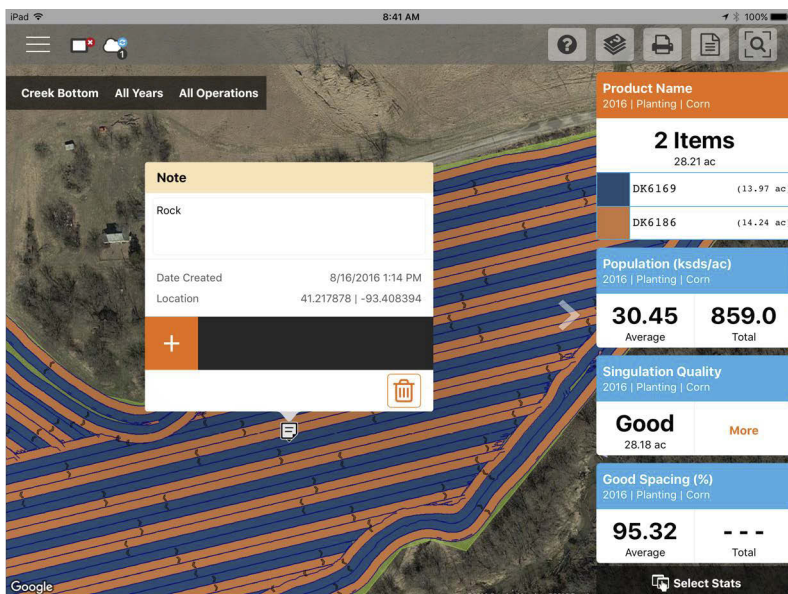

Tap and Hold on a specific location of a field to add a note. In the popup, enter a description by tapping in the description field. To link an image, tap the plus sign and choose to either take a new picture or link an existing one.



Tap and hold to add a note.

Once the note is created, move it by tapping and holding on the note and dragging it to the desired location. Also, delete the note if needed. Only notes added in this way can be edited. Marks and Notes imported from an InCommand™ display cannot be altered.

The AgFiniti Essentials license will allow notes to sync with AgFiniti Mobile, AgFiniti cloud, other iPads, and SMS. Field Notes created in SMS will sync to AgFiniti Mobile.

# Print

The screenshot shows the AgFiniti mobile app interface on an iPad. The top status bar displays 'iPad', '1:56 PM', and '89%' battery. The app header includes 'Done', 'Print Layout', and 'Print/Save'. The main content area is divided into several sections:

- Product Name:** 2016 | Planting | Corn, 27.80 ac.
- 2 Items:** A table listing two items: DK6169 (13.76 ac) and DK6186 (14.04 ac). The total area is 27.80 ac.
- Population (ksds/ac):** 2016 | Planting | Corn. Average: 30.73, Total: 854.3.
- Date / Time:** 2016 | Planting | Corn. Start: 8/10/2016 7:24:38 AM, End: 8/10/2016 9:23:30 AM.
- Singulation Quality:** 2016 | Planting | Corn. Good: 26.10 ac, More.

A 'Print Options' sidebar is open on the right, showing 'Page 1 of 2' and two toggleable options: 'Map' and 'Marks/Notes', both currently turned on.

To print any map, tap the Print icon and a preview will appear. If there are any notes/marks associated with this field, they will be automatically displayed on additional pages. If there are images associated with the field notes, they will also be included in the print layout. Both the map and marks can be toggled on/off along the right side. To print, tap Print/Save. Choose your desired print or save option from

the list presented.



**NOTE!:** To filter the notes, they will need to first be filtered by going to the menu.

## Summary Reports

AgFiniti Mobile provides a quick and easy process to view one or more field(s) data in tabular form. To view tap the Summary Reports  button in the top bar.

Begin choosing which data to include in the report. The reports can be as specific or broad as desired: view a single field's planting information or look at the grain harvest information for all fields in AgFiniti Mobile. Change the filters at the top and the report will automatically update.

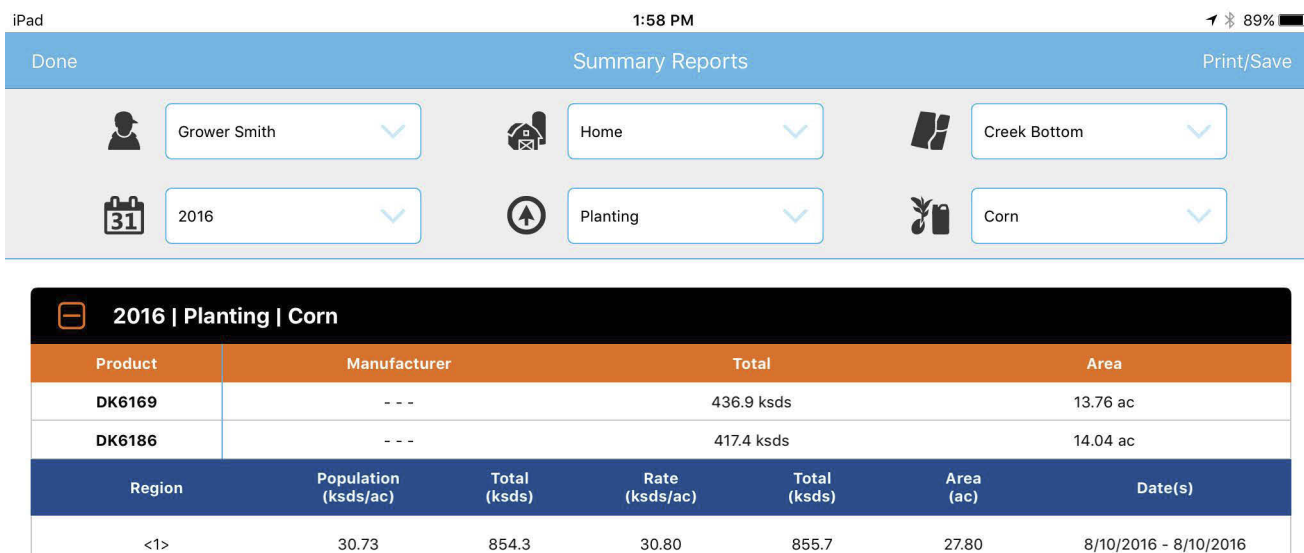

2016   Planting   Corn						
Product	Manufacturer		Total		Area	
DK6169	---		436.9 ksds		13.76 ac	
DK6186	---		417.4 ksds		14.04 ac	
Region	Population (ksds/ac)	Total (ksds)	Rate (ksds/ac)	Total (ksds)	Area (ac)	Date(s)
<1>	30.73	854.3	30.80	855.7	27.80	8/10/2016 - 8/10/2016

Depending on the chosen data, expand the 'plus' sign and view product specific information. For example, when viewing a report containing planting maps, the expanded area will include information for each unique product or, if utilizing variety tracking, display average yield by variety.



**NOTE!:** To print the displayed report, tap Print/Save. Choose your desired print or save option from the list presented.

## Menu button



**My Operation** can be set as General, Grain Cart, or Truck.

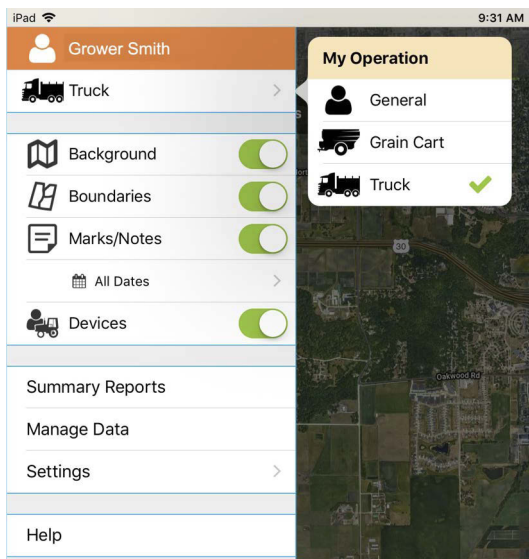

**Backgrounds**—Turn satellite imagery on or off

**Boundaries on/off**—Turn boundary indicators on or off

**Marks/notes on/off**—Turn imported marks and notes on or off

**Adjust date filter**—Adjust date range of marks/notes that are mapped. This filter is also used for printing.

**Devices**—Toggle device indicators to show/hide location of displays and mobile devices in your operation.

**Settings options**—Change units of measure and cloud

sync options

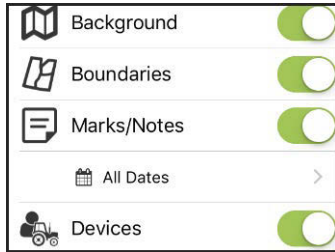

## Manage Data

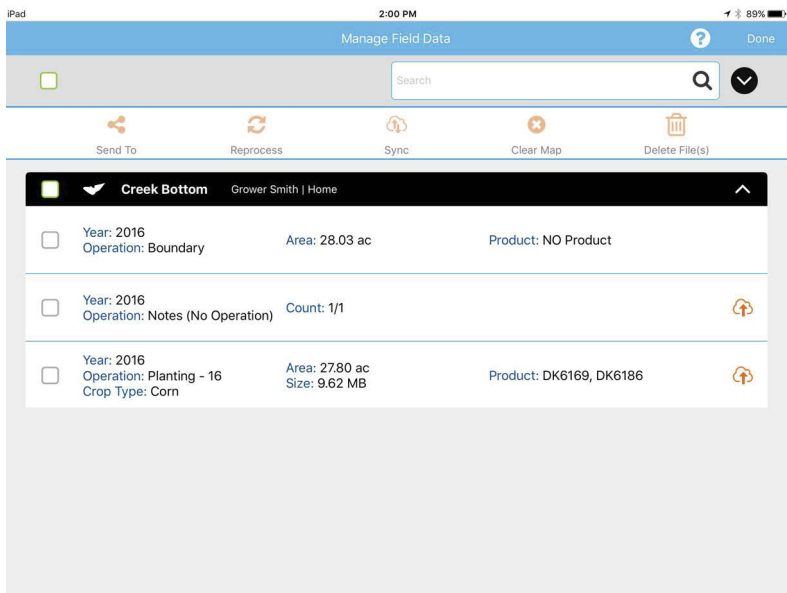

Share InCommand data, free up hard drive space, and manually sync items.



Use the tap gesture to make selection.

## Manage Data



To send data via email or third party sharing app, select the appropriate data and tap on the Send To button. Due to size limits, only one fields worth of information can be sent from within the app at a time. Multiple fields can be shared at once using AgFiniti cloud.



View a previously cleared map, choose the desired data and tap Reprocess.



To manually sync data between AgFiniti Mobile and AgFiniti cloud, select the desired data and tap Sync. To make this happen automatically, see [AgFiniti Essentials - Cloud Sync on page 73](#).



The delete button will remove specific maps and data completely from AgFiniti Mobile.



Unused GFF will also be removed upon deletion. The delete button will remove specific maps and data completely from AgFiniti Mobile.

To use this option, use the Clear Map button first and remove processed maps.



**NOTE!:** Data synced from SMS cannot be sent out of AgFiniti Mobile using the Send To tool.

### AgFiniti Essentials - Cloud Sync

With an AgFiniti Essentials license, all data and maps are synced so that data is always available using AgFiniti cloud or AgFiniti Mobile. Data can come from:

- Ag Leader InCommand data synced with AgFiniti Mobile
- Ag Leader InCommand or legacy (Ag Leader Integra or Versa) displays using wireless file transfer.
- Any AGDATA file manually loaded into AgFiniti cloud
- SMS - Most SMS data can be exported to AgFiniti (including soil survey data, soil sampling sites, and data from 3rd party displays)

Once data has been synced to AgFiniti Mobile, an active internet connection is no longer needed, and maps can be viewed anywhere. Once the data is present in the app, it can be utilized just like data synced directly from an InCommand display.

Logging into AgFiniti

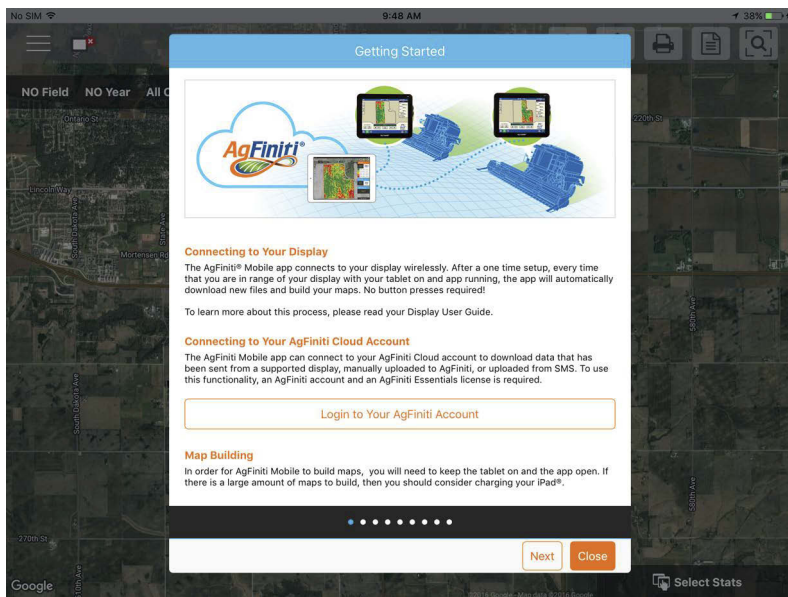

To login, go to the help icon  located on the main AgFiniti Mobile screen and tap "Login to Your AgFiniti Account"

or tap the menu button  and "Log In" and use AgFiniti login credentials to sign in.

 **NOTE!:** When logging in, all AgFiniti Mobile data on the device will be synced to the AgFiniti account used

to log in. Prior to logging in, delete specific data that should not be connected to that account.

After logging in, additional icons appear next to the display connection icon indicating the status of both connection and syncing

 Indicates a connection to AgFiniti cloud has been made. At this time, AgFiniti cloud is checking to see what data is not currently on the iPad and is preparing the necessary files to sync. By default, only the current and previous year will be synced.

 Indicates that data is being synced to/from AgFiniti cloud. Once the data is synced to the app, an icon indicating maps are being built (same as data imported from InCommand) appears.

Tap any of these icons for additional details.

## Sync Settings

In order to adjust the cloud sync settings, tap on the Menu button - Settings - Cloud Sync

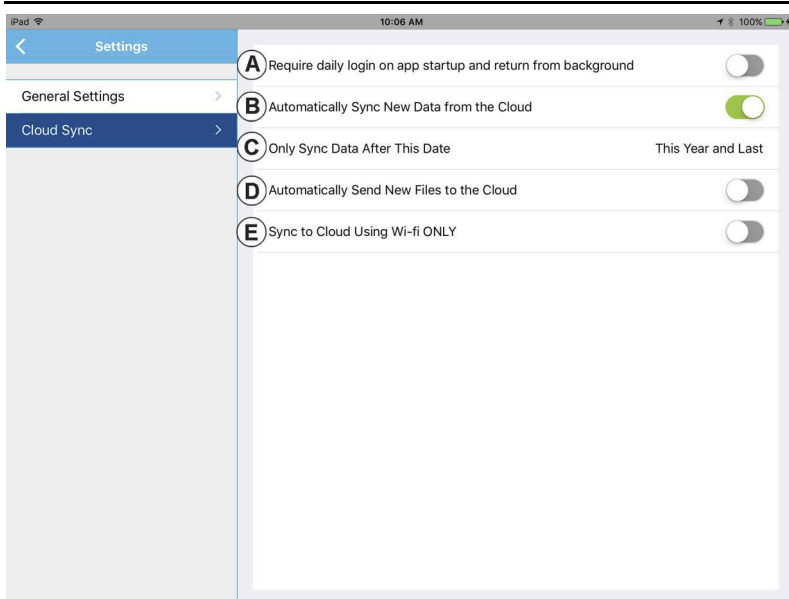

**(A) Require daily login on app startup and return from background**—If this option is left off, the logged in user will remain logged in until another user logs in. If this option is on, a login is required once daily when the app is started.

**(B) Automatically Sync New Data from the Cloud**—Allows for data present in AgFiniti cloud to be automatically downloaded to the app

once a connection is made. This provides the ability to see newly recorded data that has been transferred to the AgFiniti cloud by supported displays or SMS.

**(C) Only Sync Data After This Date**—Choose what year(s) of data to sync with AgFiniti cloud. By default, only the current and previous year of data will be automatically synced down to AgFiniti Mobile. To only see data for a specific field, manually download by going to Manage Data in the menu.

**(D) Automatically Send New Files to the Cloud**—Allows for the automatic transfer of newly synced InCommand data to be automatically sent to AgFiniti cloud. This will allow for instant access to newly recorded data to everyone on the AgFiniti account, providing quicker access to those that need it.

**(E) Sync to Cloud Using Wi-Fi ONLY**—By default, AgFiniti Mobile will sync with AgFiniti cloud using a cellular connection if Wi-Fi is not available. If this option is enabled, syncing will only occur over a Wi-Fi connection. Transferring over a cellular network could potentially use a large amount of data. Turning this option on prevents this from occurring.

## Display and Device Location

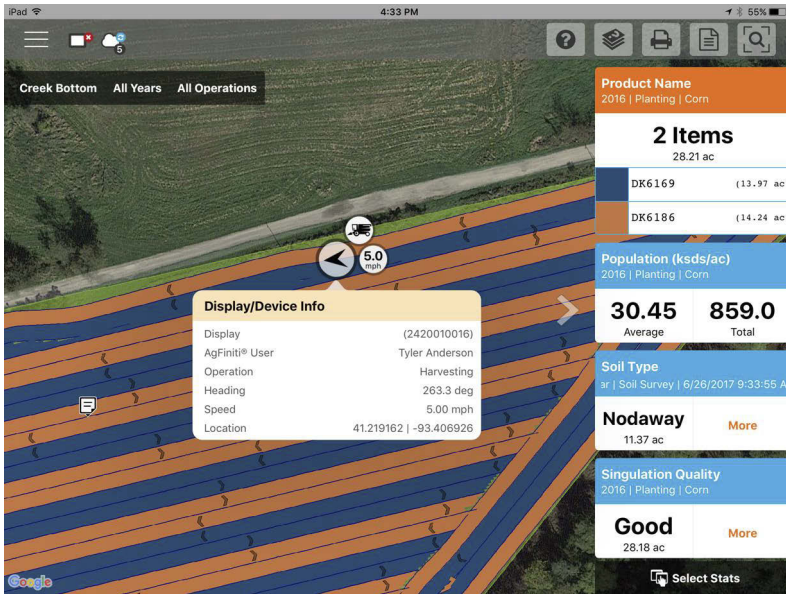

An AgFiniti Essentials license allows for display and device location indicators to appear in AgFiniti cloud and AgFiniti Mobile. Any displays or devices (iPads running the app or devices logged into AgFiniti cloud) will be displayed. The indicator will include position, direction of travel, speed, and current operating state. Tap on the position indicator to get additional details for that specific display/device.

You can toggle these on/off from within the app menu.

## Live Stats - Mobile

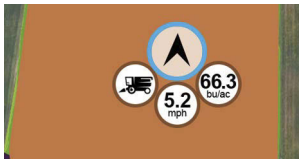

Live Stats indicators are present with the device location on the InCommand and AgFiniti Mobile. The indicators will represent the main attribute, speed, and operation for any device logged into AgFiniti.

Live Stats will be shown for these operations: planting/seeding, application, (liquid and dry), Harvest (grain and forage), and site verification (will be missing main attributes indicator).

Live stat data and device location are updated on a 5 second interval.

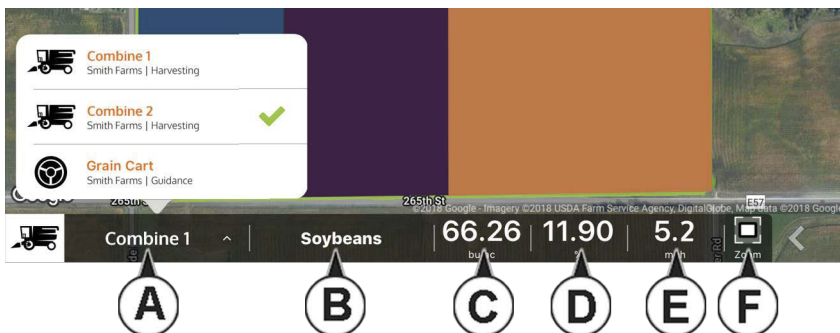

The Live Stats bar provides more live stat data for each device logged in. It will always be present as long as the device is logged in.

A. Device Selection - Selected device displays its current stats in the bar. Device can be selected from this list, or by pressing on the device location in the app.



a. Device is identified by the display’s nickname or ipad name (nickname will only update upon each log in). If no display nickname is entered the displays serial number will be shown.

B. Product

a. For planting, individual varieties will be able to be selected.

C. Main Attribute

a. Rate and Yield

D. Secondary Attribute

a. Population percentage, container level, and moisture

E. Speed

F. Zoom

a. Pressing this allows the user the move the map directly over the top of the device selected in the live stat bar.

**Live Maps – Mobile**

Live maps allow AgFiniti Mobile users to view their active events maps on the iPad by using DisplayCast.

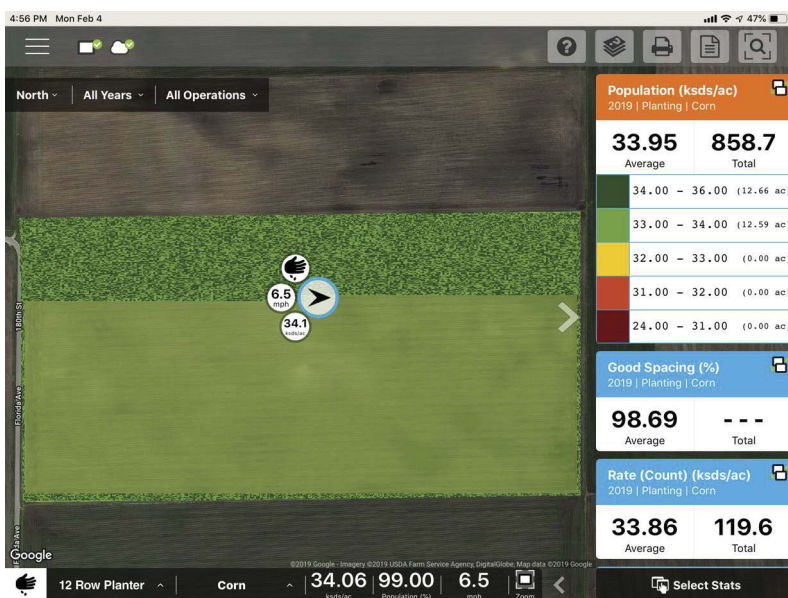

Live maps available within AgFiniti Mobile will appear with a DisplayCast icon next to the field name in the field filter. Additionally the DisplayCast icon will be present on stat cards showing live information. Live map information is available to view for up to 24hrs after an event is suspended or closed on the display.

**Requirements**

1. One or more InCommand displays

with DisplayCast unlocked

2. InCommand version 4.2+
3. AgFiniti Essentials license
4. iPad with AgFiniti Mobile app

---

5. All devices logged into the same AgFiniti account.

### Operation and Maps Viewable

- Planting
- Liquid Application
- Dry Application
- Harvest
- Tillage
- Site Verification
- Vehicle Maps
- Seeding

 **NOTE!:** Area Remaining available for LiveMaps

### AgFiniti Display Settings



### Logging into an AgFiniti Account



Press the login button and enter in the AgFiniti account user name and password. After entering proper credentials the display will be logged into AgFiniti cloud and the user can access services available on the account. Once logged into an AgFiniti account, the display becomes registered to the users AgFiniti account and will automatically login on display startup if internet access is available.

### Logout and De-register Display

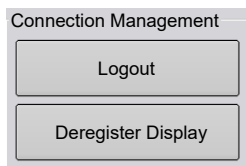

**Logout**—This will log the display out of the current AgFiniti Account. If the user does not want to automatically connect AgFiniti cloud on startup they must logout. Logging out of an AgFiniti account does not deregister the

display from an AgFiniti Account.

**Deregister Display**—When logged into AgFiniti cloud the user can deregister the display from their AgFiniti account. This will unlink any AgFiniti licenses tied specifically to the display.

### Mobile Management

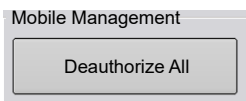

The “Deauthorize All” button will deregister any mobile devices that have been authorized to access the display’s logged data.

### File Transfer

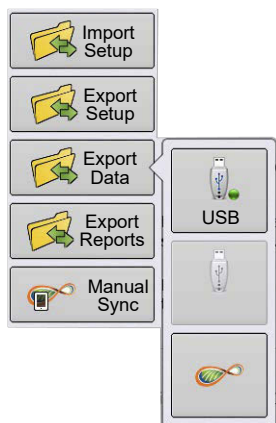

To use file transfer on the InCommand display, the following requirements need met:

1. User account created at <https://www.agleader.com/farm-management/agfiniti/>.
2. InCommand display connected to internet source via WI-FI adaptor.
3. Be logged into AgFiniti account on InCommand Display.
4. AgFiniti will become an available option when an import or export function

is chosen from the data transfer page.

5. Press the AgFiniti symbol to export to AgFiniti cloud.

### Remote Support

To use remote support on the InCommand display, the following requirements need met:

1. User account created at [www.agfiniti.com](http://www.agfiniti.com).
2. Annual Essentials License purchased and active on account attempting to remote support a display.
  - The end user DOES NOT need to have an Essentials license.
3. InCommand display connected to internet source via WI-FI adaptor.
4. Be logged into AgFiniti account on InCommand Display.

5. From <https://www.agfiniti.com/Account/Login> a user can remotely view the display.

**i** **NOTE!** For information on how to setup sharing relationships to allow pre-authorized remote support viewing as well as sharing data with trusted advisors, please visit [support.agleader.com](https://support.agleader.com).

## Remote Support Pre-authorization

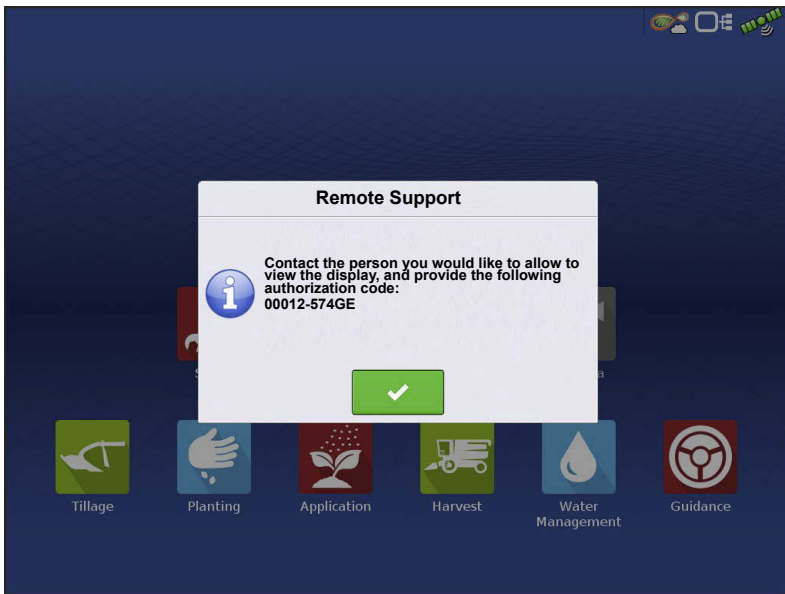

Pressing the remote support button will generate a 10 digit code that can be verbally communicated to remote viewer to initiate the viewing session.

## Remote Support Permissions Options

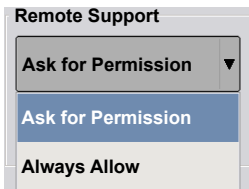

**Ask for Permissions**—This selection will require the display user to grant remote user permission to view the display.

**Always Allow**—Allows remote viewer to view display screens without display user having to give permissions.

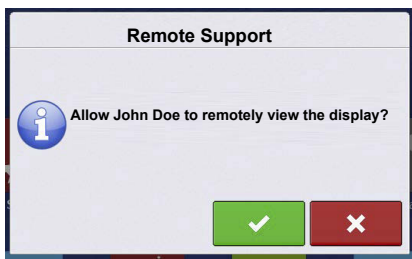

 Allow remote viewer access to view the display.

 Deny remote viewer access to view the display.

When a remote view session has been initiated the status bar at the top of the screen will turn from blue to green.



## Cellular iPad as Personal Hotspot Connection

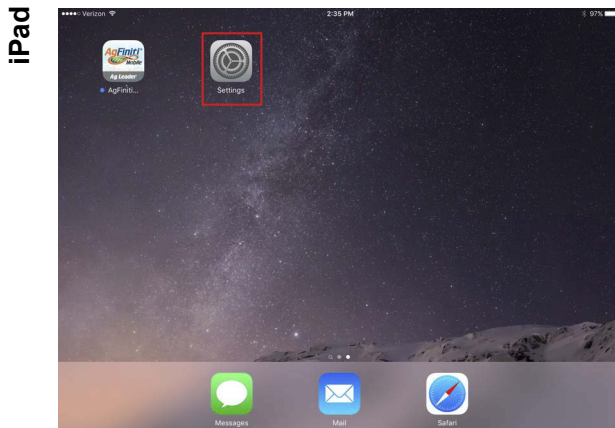

1. To enable Personal Hotspot mode on the iPad, go to the Settings app.

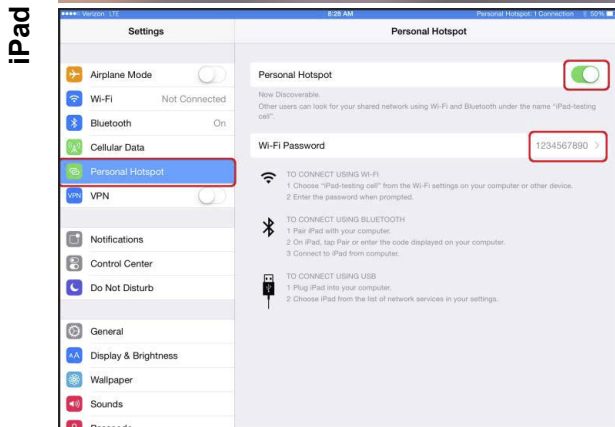

2. Select Personal Hotspot from the left side menu and enable by pressing the on/off switch from the top right side. Once enabled take note of the Wi-Fi password as it will be needed in the next step.

 **NOTE!:** This password can be changed if desired.

InCommand Display

InCommand Display

3. With the Wi-Fi adaptor installed in the InCommand display, the AgFiniti symbol  will show in the top right corner of the display.

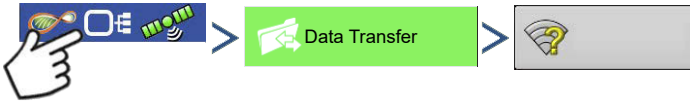

InCommand Display

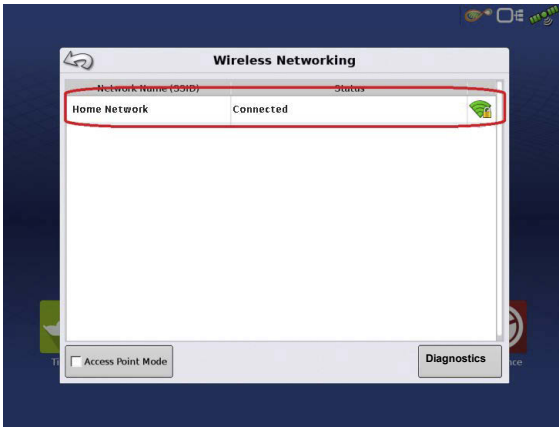

4. On the Wireless Networking page select the iPad from the list. If the iPad isn't available from the list try turning the personal hotspot mode on the iPad off and then back on.

InCommand Display

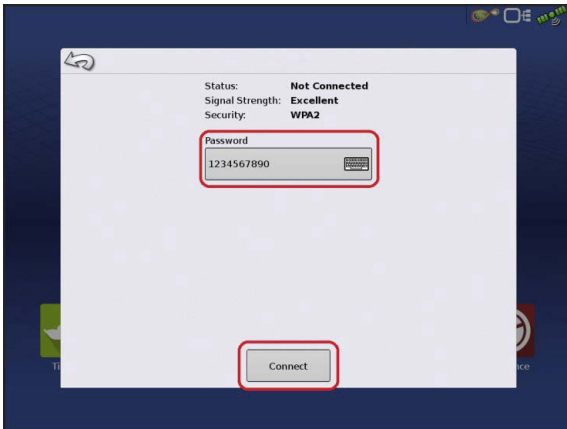

5. Enter the password and press Connect.

6. The display will then be connected to the iPad.



**NOTE!:** Repeat steps 1-6 each time the iPad is brought into the vehicle.

iPad

iPad



7. On the iPad, open the AgFiniti Mobile app. Once the AgFiniti Mobile is open, it will automatically attempt to connect to the InCommand display.



**NOTE!:** Download AgFiniti Mobile from the Apple App store.

InCommand Display

InCommand Display

8. Once the InCommand display has been found the display will prompt user to allow connection to happen.



**NOTE!:** This should only happen once per device.

9. After pressing  the mobile device will begin accepting data from the display as it becomes available. The AgFiniti Status Indicator will show a device symbol within it on the top right corner of the screen.



**NOTE!:** If display is logged in to AgFiniti cloud a cloud symbol will also appear in the AgFiniti Status Indicator.

InCommand display and iPad are connected and ready for data transfer. If there are any closed or suspended events present on the InCommand display, they will be transferred.

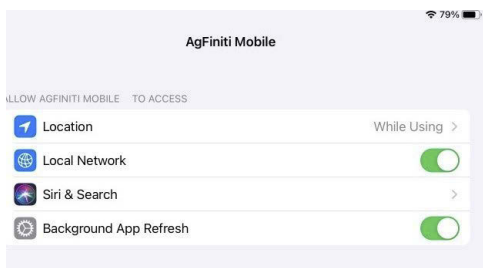

**NOTE!:** This should only happen once per device. If connection is declined, will need go to Settings App (on iPad) – AgFiniti Mobile – toggle on Local Network.

## Shared Wi-Fi Network Connection

1. With the Wi-Fi adaptor installed in the InCommand display, the AgFiniti symbol  will show in the top right corner of the display.

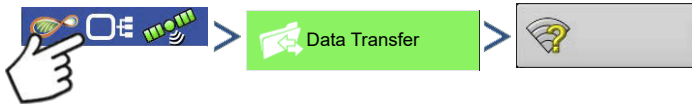

2. On the Wireless Networking page, press to select the desired network. This will prompt for a password, if needed, to connect to the network.



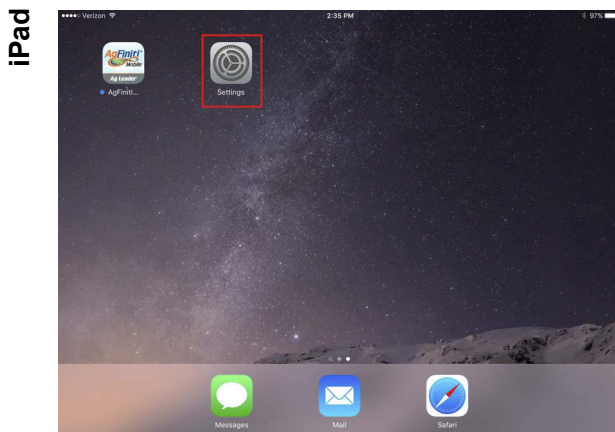

3. Connect the iPad to the same WiFi network by going to the Settings app.

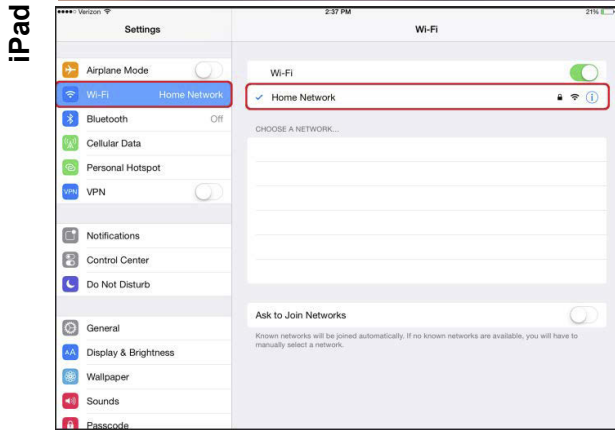

4. Select the “Wi-Fi” tab from the left side menu followed by highlighting and connecting to the appropriate wireless network.

5. Both the display and the iPad should now be on the same network.

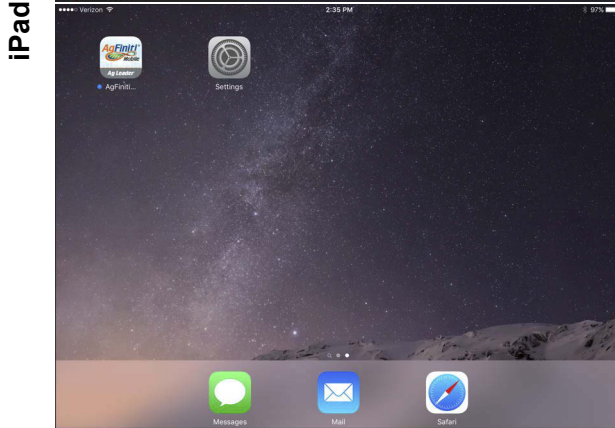

6. Open AgFiniti Mobile app on the iPad.

 **NOTE!:** Download AgFiniti Mobile from the Apple App store.

7. Once the AgFiniti Mobile is open, it will automatically attempt to connect to the InCommand display.

---

## InCommand Display

InCommand Display

8. Once the InCommand display has been found the display will prompt user to allow connection to happen.



**NOTE!:** This should only happen once per device.

9. After pressing  the mobile device will begin accepting data from the display as it becomes available. The AgFiniti Status Indicator will show a device symbol within it on the top right corner of the screen.



**NOTE!:** If display is logged in to AgFiniti cloud a cloud symbol will also appear in the AgFiniti Status Indicator.

At this point the InCommand display and iPad are connected and ready for data transfer. If there are any closed or suspended events present on the InCommand display, they will be transferred to the iPad once the app is opened.

---

## DisplayCast®

DisplayCast is a feature available for unlock on InCommand™ displays. Through AgFiniti® Cloud, users have the ability to seamlessly sync maps, summary values, and other management information between any InCommand displays in the operation. DisplayCast enables better decision making in the cab and increases productivity by giving easy access to all operational data on every InCommand display in the operation.

### How it works

As each display using DisplayCast syncs data, AgFiniti Cloud compiles and tracks what data is available from each display and makes sure all displays in the operation are kept up to date.

### Use cases

1. I have multiple InCommand displays on the farm and need to make sure all displays have matching fields names, boundaries, and guidance lines.
2. I plant with two InCommand displays and need to get my variety maps combined to a single InCommand display in my combine.
3. I run two or more pieces of similar equipment in the field at the same time.

Listed below are three example of the many types of equipment that could be performing the same task, at the same time, in a field.

- a. Two or more planters operating at once
  - b. Two or more sprayers operating at once
  - c. Two or more combines operating at once
4. I run two or more different pieces of equipment in the field at the same time.

Listed below are four example of the many types of equipment that could be performing different tasks, at the same time, in a field.

- a. Planter and Tillage
  - b. Planter and applicator
  - c. Combine and grain cart
  - d. Combine and tillage
5. Two similar pieces of equipment in different fields at the same time.
  6. Two different pieces of equipment in different fields at the same time.

### Information that is synced

1. Management information (Growers, Farms, Fields)

- 
2. Configurations
  3. Products
  4. Guidance Lines
  5. Maps for AutoSwath
  6. Reference and attribute maps
  7. Logged events
  8. Summary information

### Requirements list

1. AgFiniti Account created at [www.agfiniti.com](http://www.agfiniti.com)
2. AgFiniti Essentials License
3. DisplayCast feature unlock on all participating displays
4. Active internet connection on the display
  - a. 3G or better cellular coverage
  - b.  **NOTE!:** Ag Leader recommends using a dedicated modem such as the Ag Leader BR1 Mini for internet access when using DisplayCast.
5. Be aware of GPS accuracy differences between two machines (for example Autoswath could have increased overlaps or gaps based on GPS differences).
6. **Each configuration, vehicle, implement, controller must be unique for the equipment that it is used on.**
  - a. Having unique naming ensures accurate records and minimizes the chance of the incorrect configuration being used which could lead to Autoswath and controlling errors.

### First time setup and sync

With the InCommand display unlocked, an active AgFiniti Essentials license, and internet access on the display; DisplayCast will automatically start to synchronize all information to AgFiniti Cloud. The first time the InCommand Syncs with AgFiniti Cloud it may use a large amount of data. Using an unrestricted data plan may be desired the first time the display synchronizes with AgFiniti Cloud.

## Data syncing intervals

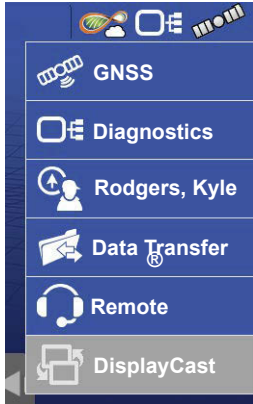

1. Coverage and attribute maps in active events sync at approximately 5-10 second intervals.

2. New field names and guidance lines sync within a few minutes after being created.

3. Summary information syncs every 10-20 minutes.

4. Manual Sync: The Sync button can be pressed at any time. This will sync all new information to AgFiniti Cloud and update the display with any new information from other displays.

5. AgData files will be exported on event close and at end of day, this data will then process into AgFiniti to be viewed immediately in either AgFiniti cloud or mobile
6. Management Information and Summary information will also be synced and processed for viewing in AgFiniti Map View and Mobile on the 10-20 minute sync interval.
  - Management Info—Growers, farms, fields, boundaries, products, equipment.

This is a one way sync. Management/Summary data added to Map View via SMS will not sync back to the displays through DisplayCast.

## Getting started

With DisplayCast unlocked on the display a new DisplayCast icon is available under the Status Indicator button. The DisplayCast menu houses the available sync options.

## Sync options

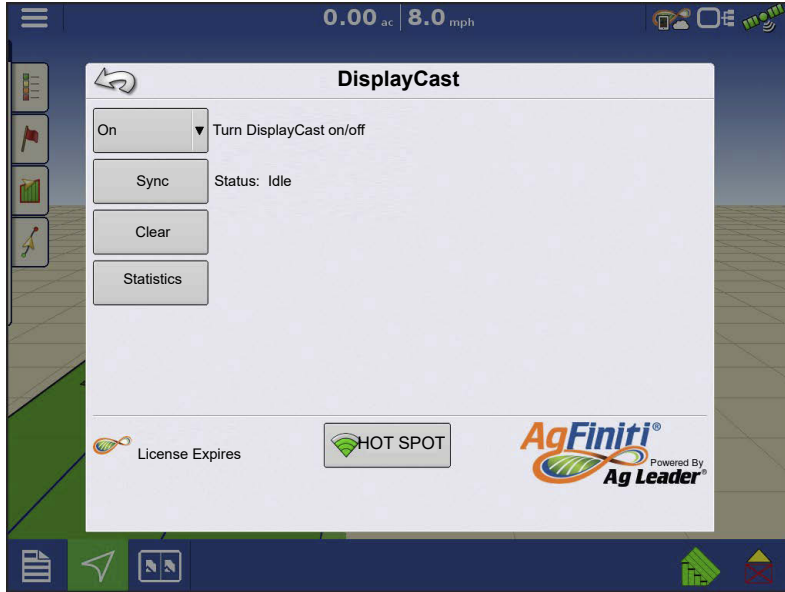

<b>Off</b>	<b>Off</b> — DisplayCast will not send or receive data to AgFiniti
<b>On</b>	<b>On</b> — DisplayCast will automatically sync data with AgFiniti at regular Data Syncing intervals
<b>Manual Only</b>	<b>Manual Only</b> — DisplayCast will only sync when the Sync button is pressed.
<b>Sync</b>	Sync is used to manually sync data with AgFiniti. This action can be done at any time without disabling data logging.
<b>Clear</b>	Removes the current DisplayCast information from AgFiniti.
<b>Statistics</b>	Shows time of display update, AgFiniti update, position update, and a lists of displays logged into AgFiniti.

### Sync Status States:

- Idle
- Downloading DisplayCast® sync information
- Importing DisplayCast® sync information
- Exporting DisplayCast® sync information
- Uploading DisplayCast® sync information
- Updating DisplayCast® sync state
- Downloading DisplayCast® map files
- Importing map files
- Exporting map files
- Uploading DisplayCast® map files

## DisplayCast Error Messages

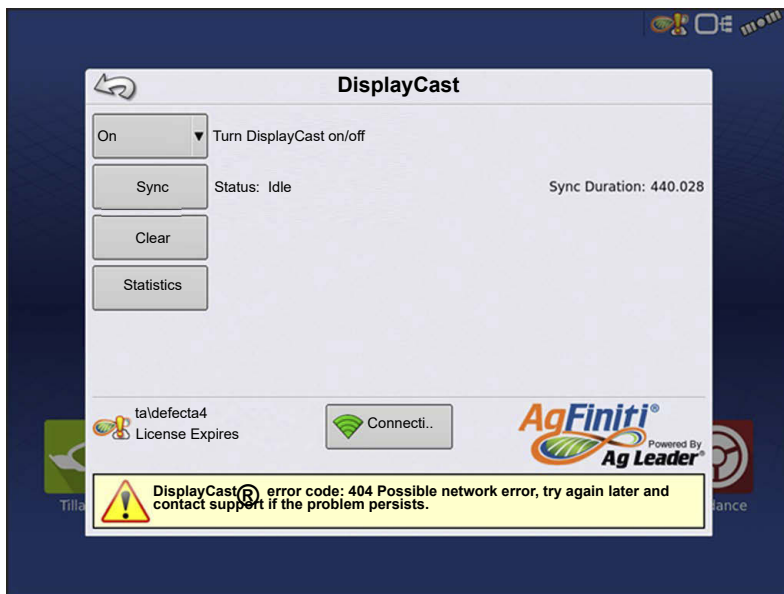

If the DisplayCast process is affected at any point, specific error messages will occur at the bottom of the DisplayCast screen. These messages can be used to decipher what has specifically occurred. For a detailed list of errors, please reference <https://portal.agleader.com/community/> for more information.

## DisplayCast Season Management

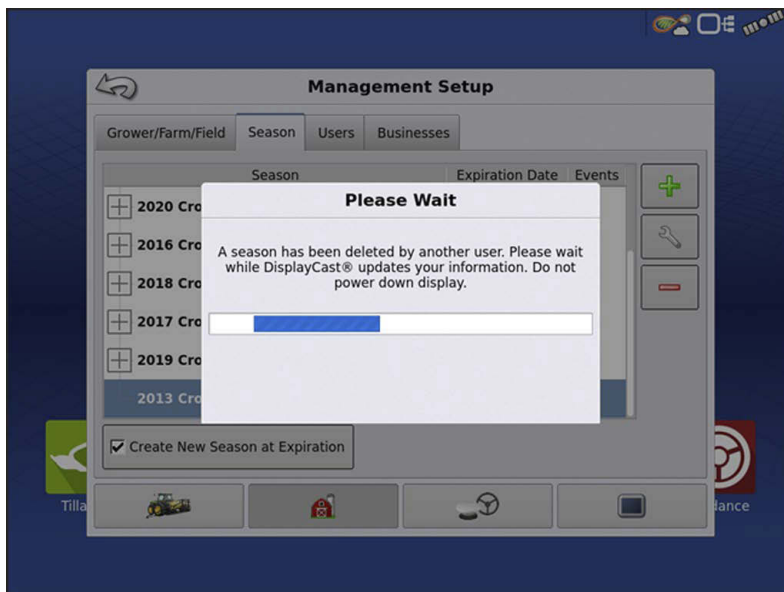

When using DisplayCast and deleting a season, other displays will see notifications that a season has been deleted. If other displays are using the deleted season, they will need to sync and export data before being able to utilize DisplayCast functionality again. This will ensure that all logged data is exported out before the season is deleted.

On other displays running, the message shown will be displayed while the deleted season is removed. In the rare instances where the user is logging data to a deleted season or still has logged data present from a deleted season, simply return to home screen after closing the active event and/or export log files out to complete the deletion process.

If you notice that DisplayCast functionality is still not present, next perform a manual DisplayCast sync and export out log files to resolve the stoppage.

# Network Diagnostics



OR

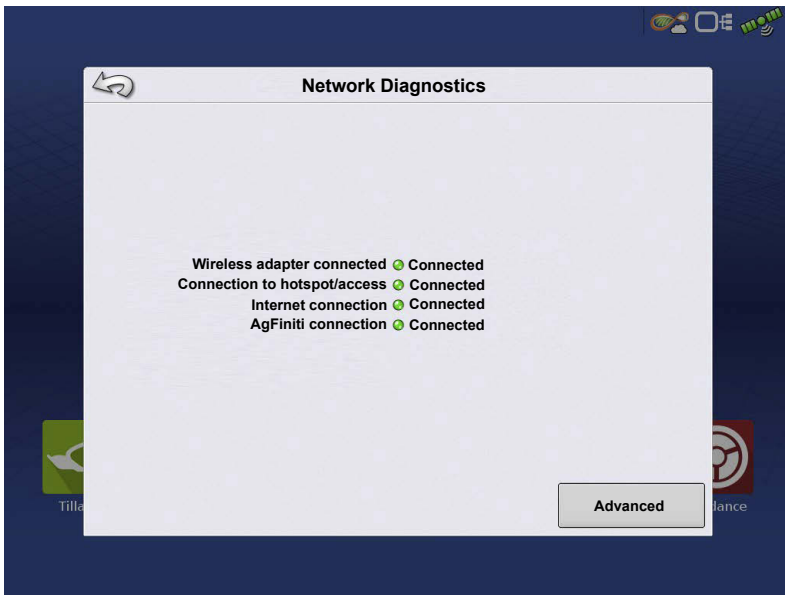

Network Diagnostics shows users network status via color indicators below.

Light status

- Green-connected (Working Properly)
- Yellow-checking status
- Red-Needs attention

 **NOTE!:** Refer to the text to the right of the diagnostic lights for

additional information on status.

# DisplayCast Statistics





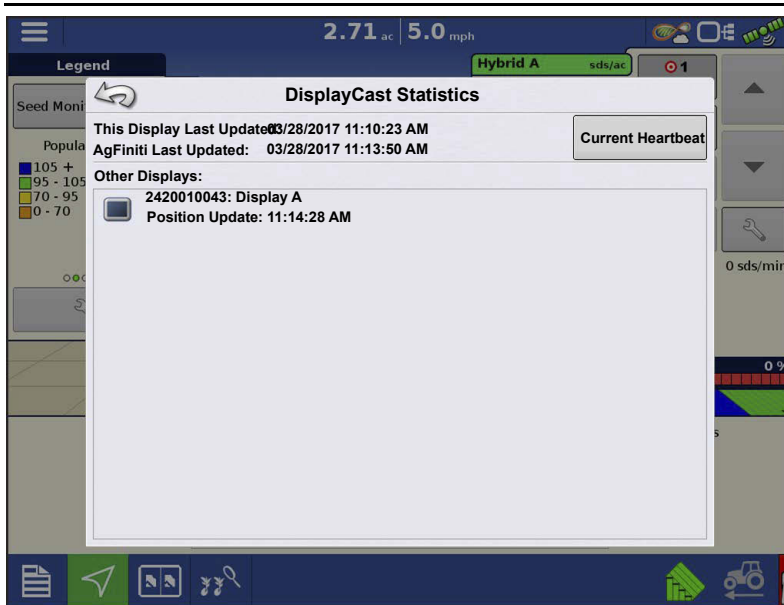

As each display syncs with AgFiniti Cloud, the statistics page will update to reflect the information below. (This can be used to troubleshoot data sync issues.)

- This Display Last Updated – Timestamp of most recent data sync from AgFiniti Cloud to current display.
- AgFiniti Last Updated – Timestamp of most recent data sync to AgFiniti Cloud

from any display.

- Other Displays – Lists any displays logged into AgFiniti by serial number and active configuration.
- Position Update – Timestamp of last received GPS position for that display.
- Current Heartbeat – Live stat information sent to the AgFiniti cloud.

## Starting an event for multiple displays in the same field and operation

InCommand displays running the same operation and sharing maps for Autoswath must be in the same event. If each display starts separate events the maps will not automatically update on screen for Autoswath

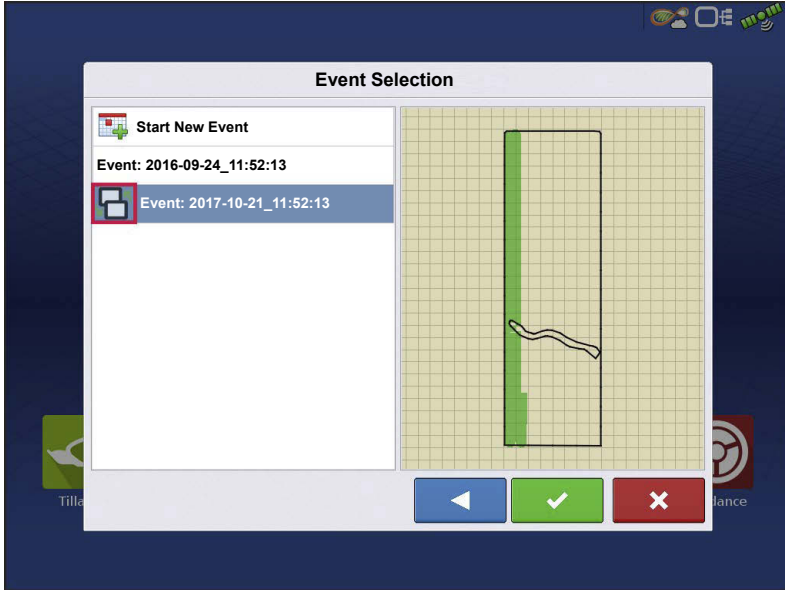

1. The first display to the field starts the initial event and loads a configuration to the Mapping screen.

2. An active event will be available to load during the Field Operation Wizard for all other displays in the operation to select.

a. Active events within the same operation are identified with a DisplayCast symbol next to the event name. Additionally the preview window will populate and update with

the current coverage for the field.

b. From this point forward, the coverage and attribute maps will automatically fill in with data from all active displays in the event.

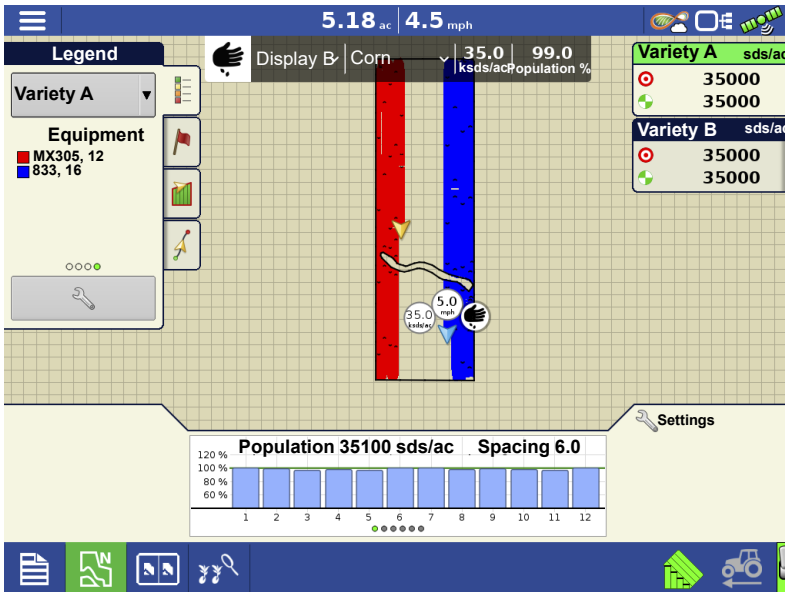

On the Mapping screen, each machine logged into AgFiniti will have a vehicle icon indicator.

 Gold icon represents current vehicle location

 Blue icon represents other vehicles in the same field.

## Live Stats—DisplayCast

Live stat indicators are present with the device location on the InCommand and AgFiniti Mobile. The indicators will represent the main attribute, speed, and operation for any device logged into AgFiniti. The InCommand requires the DisplayCast unlock to display Live stats.

Live stats will be shown for

- planting/seeding
- applications (liquid and dry)
- harvest (grain and forage)
- site verification (will be missing main attribute and indicator).

Live stat data and device location are updated every 5 seconds.

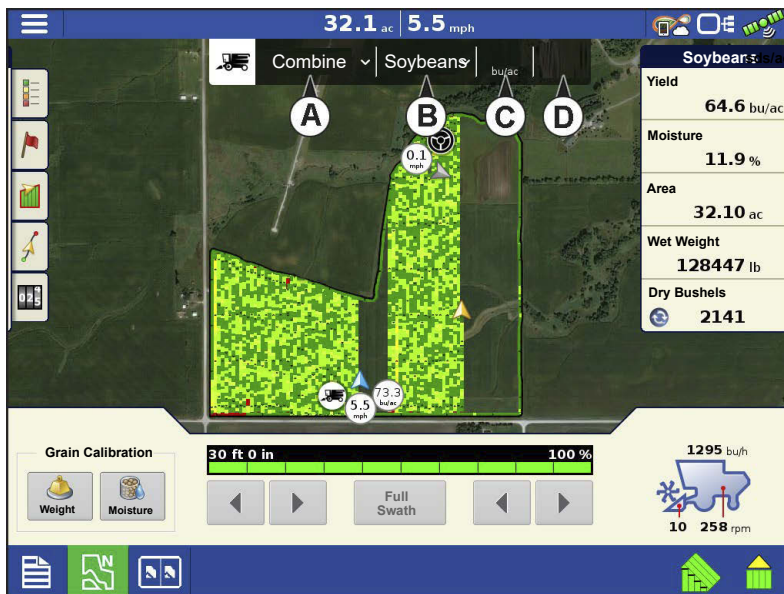

The Live stat bar provides data for each device logged in.

A. Device Selection—displays its current stats of this device in bar.

Device can be selected from this drop-down menu or by pressing on the display location on the screen.

a. Device is identified by the display's nickname or iPad name (nickname updates at login). If no nickname is entered, the display serial number will be shown.

### B. Product

- a. For planting, individual varieties will be able to be selected.

### C. Main Attribute

- a. Rate and Yield

### D. Secondary Attribute

- a. Population percentage, container level, and moisture

## Loading a Guidance Pattern while using DisplayCast

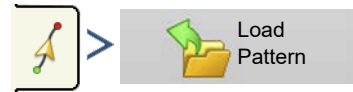
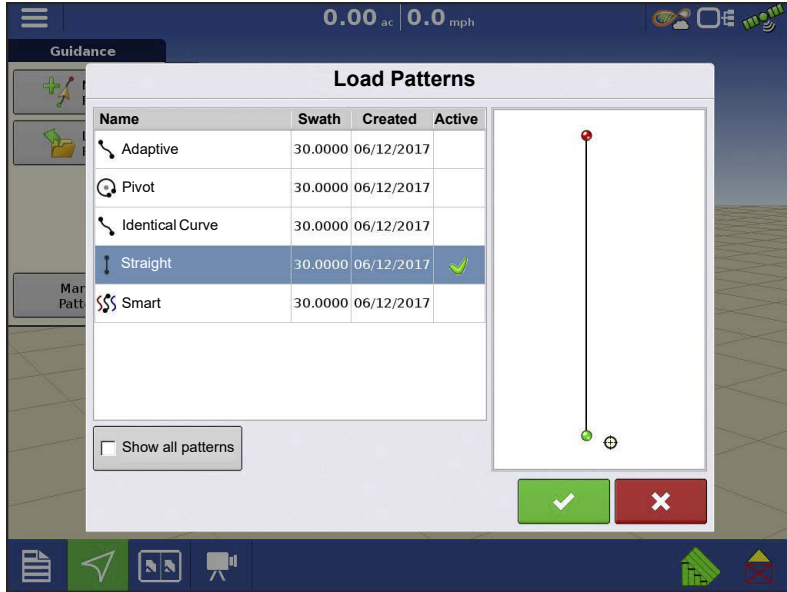

List of guidance patterns for the active field will populate after selecting load pattern.



Green Check in the Active column indicates which guidance pattern is currently in use in the same field.

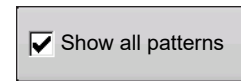

Check the box to show all patterns in the display.

Highlight desired pattern and select  to load pattern to mapping screen.

Select  to return to guidance mapping screen without loading a guidance pattern.

## Viewing active and past events for the field currently loaded on the Mapping screen

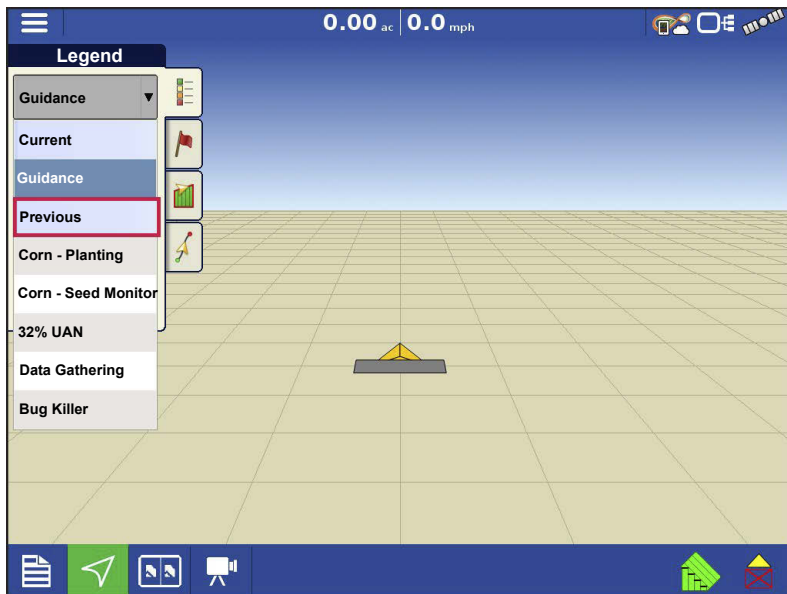

On the Mapping screen, the Legend menu drop-down gives users the ability to view any past or active events from any InCommand for the current field. Active events from a second display/operation will update in real time.

Select from “Previous” section in the list to view data prior logged for the field.

**Example:** While spraying, the planting

maps are viewable.

**Using Summary Report page to view any active or past events**

The Summary Report page has the ability to view both past and active events from any display using DisplayCast. This includes both summary information and maps, and can even be done while actively logging data on the Mapping screen.

**Viewing summary information**

**Summary Report**

Season: 2017 Crop | Grower: Demo | Farm: Home

Field: Other Land | Operation: Planting | Product: Corn

Region	Variety	Avg Rate	Total	Area (ac)	Date Created	View Mode
Instance 1		32599.9	3630599.	111.37		Agronomic
< 1 >	Seed 1	32658.7	1099685.	33.67	03/30/2017 Split Pla	Create Report
< 1 >	Seed 2	32507.3	1076775.	33.12	03/30/2017 Split Pla	View Report
< 1 >	Seed 3	32624.3	1454138.	44.57	03/30/2017 Split Pla	View Map
Field Total (All)		32599.9	3630599.	111.37		



Filter as needed

**Viewing maps on summary screen**

**Summary Map**

Equipment:  
■ Case Magum 290  
■ Case Magum 290

The map shows a field with a blue path on the left and a red path on the right, indicating the movement of Case Magum 290 equipment.



Filter as needed



## Harvest Variety Tracking with DisplayCast

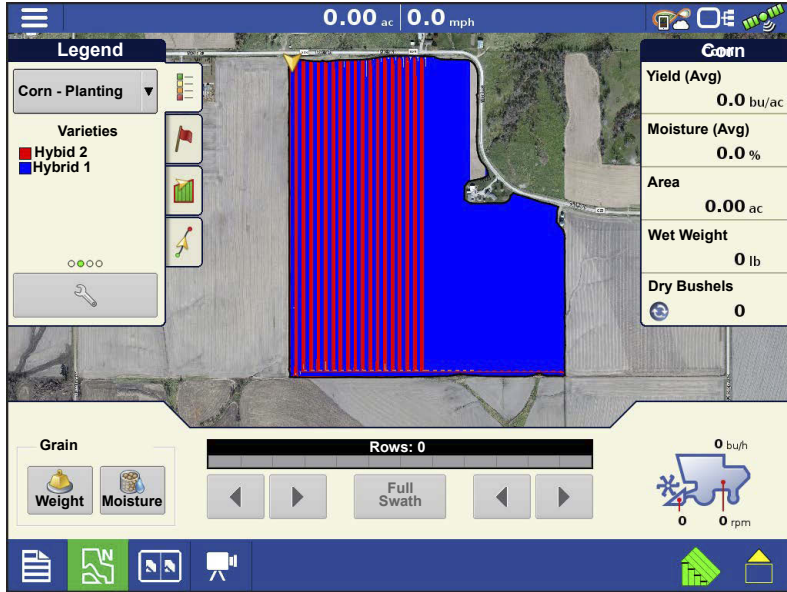

Since attribute maps are synced between InCommand displays, planting variety maps are available for Automatic Variety Tracking without needing to import from SMS™. To the right is an example of a planting variety map in which two planters planted one field using DisplayCast.

## Data management with DisplayCast

### Configurations

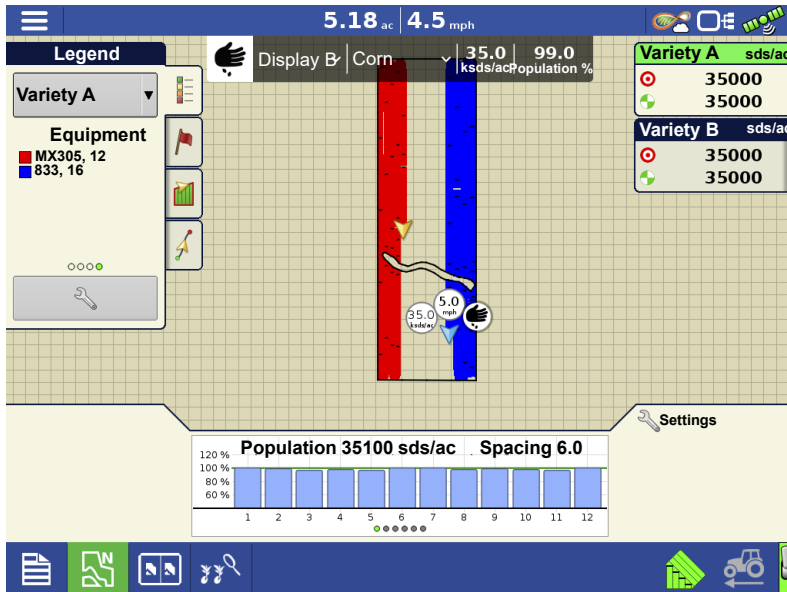

It is critical that each piece of equipment operating in the field at the same time has a unique configuration. When multiple InCommand displays operate in the field at the same time, logging is tracked based on the configuration name used on each display.

The Equipment Legend (shown to the right) displays which configuration operated in what part of the field.

### Logged data (.agdata)

Each display using DisplayCast will need to “Export Data” to AgFiniti Cloud or USB to have a complete data record. DisplayCast does not sync .agdata data between displays.

---

## Changes and updates to management Items

Adding, modifying, and deleting items when using DisplayCast works very similar to only running one display. AgFiniti Cloud will update all synced InCommand displays with the most recent information.

- **Example 1:** Display 1 deletes an unused field from the field list and syncs with AgFiniti Cloud. The next time Display 2 syncs, the field name will be removed from its field list as well.
- **Example 2:** Display 1 enters a new field name into the display but spells it incorrectly. The new field name will automatically sync with all other displays. Display 2 fixes the field name's spelling. Next time the display syncs all other displays will get updated with the correct field name spelling.
- **Example 3:** Before planting season starts a user enters all the new planting varieties for the year and deletes ones that are no longer going to be used. When the other displays in the operation are turned on at a later date the product lists will get updated with all the new products and the old products will get removed from the displays.





---

## Events

Events are used to track field operations. New events can be created at anytime and therefore a physical field can be broken into many events or recorded under one. An event contains all coverage maps created while that event was active. Events are automatically named by date and time.

The display can be run in two different modes:

- **Traditional mode**—requires user to specify a Grower, Farm, and Field for the Event. The display associates this information with setup files and logged data. When these files are reviewed or utilized in the future, it provides the operator with a greater depth of information.
- **Events Only mode**—minimizes the setup process so that the display is ready to run in the field with the least amount of setup (just a few button presses).

## Field Operations

To start a field operation, press one of the field operation apps from the home screen. This display has the ability to use guidance, tillage, and surveying configurations without extra equipment. Additionally, planting and application configurations can be created to track products without modules. The Field Operation wizard will walk through all the steps needed to begin a field operation.

**Select Field Operation app and follow the Setup wizard.**



Planting



Application



Harvest



Water Management



Guidance



Tillage

---

The following must be created:

- Grower, Farm, and Field if “Enable Management” is checked, otherwise the display will track operations based only on events.
- A Season Setup within Management tab.
- A Product (when creating an Application or Planting Field Operation) at the Setup Product tab.
- An Operating Configuration at the Setup screen’s Configuration tab. This Operating Configuration consists of Equipment, Vehicle, Implement, Controller (optional), Tank (in Application), and Ground Speed Source.

All of these are referenced by the Field Operation wizard during the Field Operation setup process.

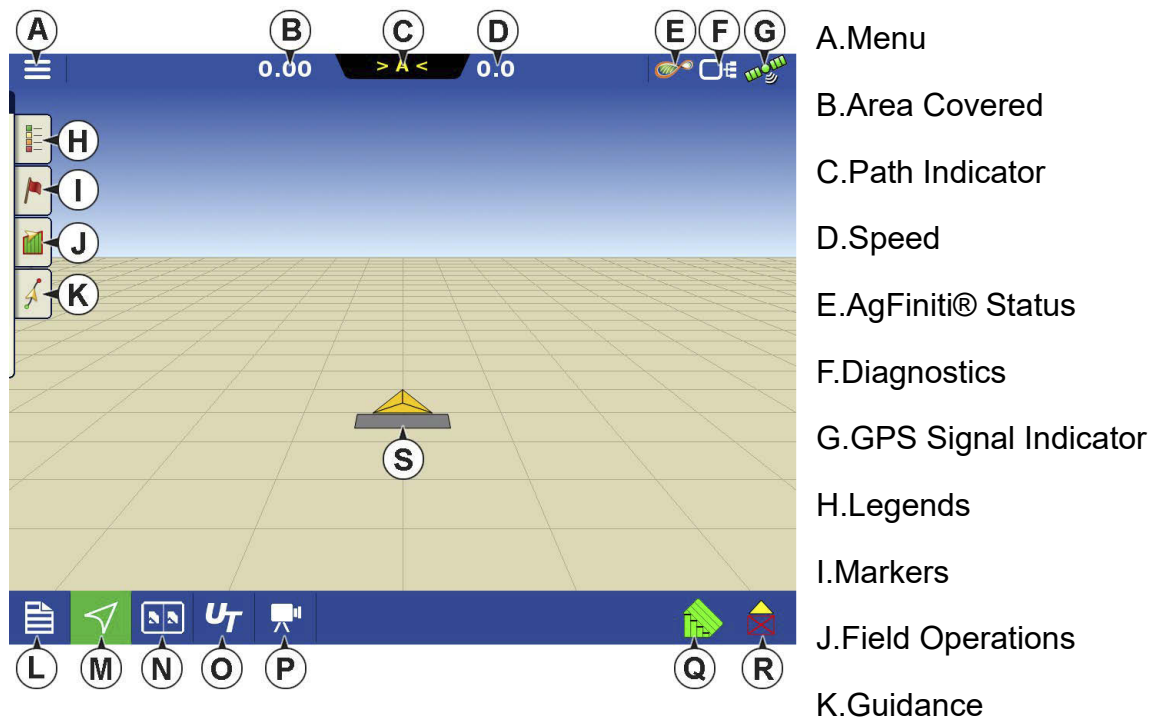

L. Event Summary

M. Map Views

N. Split-Screen (InCommand™ 1200 Only)

O. Universal Terminal

P. Video button

Q. AutoSwath

R. Logging

S. Vehicle Icon

## Heading Detection

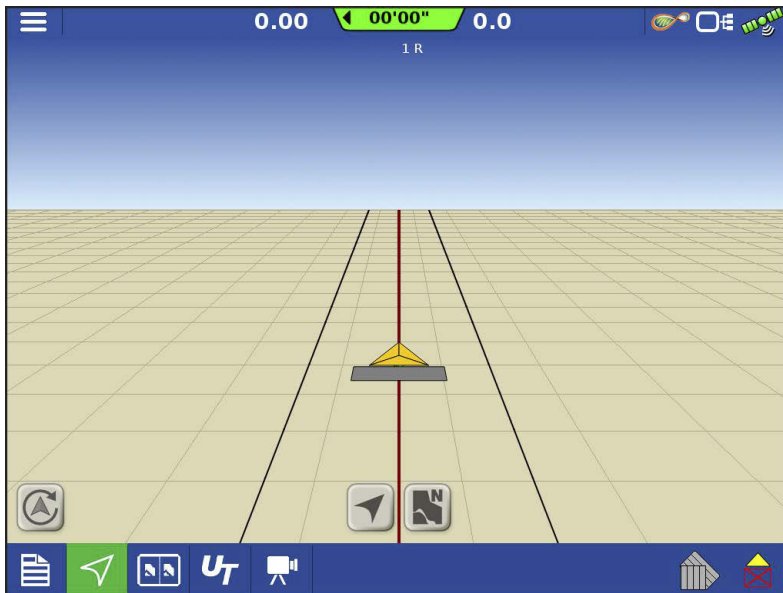

InCommand displays have built in functionality to establish and keep the correct direction of travel when using GPS receivers that do not have a trusted heading source from an internal compass or steering controller. For this functionality to work the user must first establish a forward direction of travel. The direction of travel is set automatically in the background, after acquiring GPS,

based on the vehicles first movement after starting an event.

Any time the vehicle or icon is in the reverse direction and data is being logged, an audible alarm will sound until the vehicle/icon is driving in the forward direction again.

## Heading Change Button



Any instance in which the vehicle icon appears to be upside down or rotated 180 degrees, it can be fixed with the Heading Change button. The Heading Change button can be accessed by tapping anywhere on the center of the mapping screen and pressing the icon on the lower left corner of the screen. Data logging must be turned off for the Heading Change button to work.

## Disable/Enable Heading Detection



With Heading Detection disabled, the icon will always follow the GPS heading. When using a Harvest configuration, Heading Detection is automatically disabled regardless of the state of the enable/disable button.

---

## Vehicle Icon



**Vehicle Icon—When Zoomed Out**—This gold colored triangle indicates the display is in zoom to extent mode. When in North Oriented View the vehicle implement does not appear but logged data will still populate on the map.

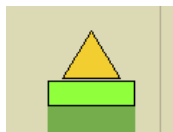

**Vehicle Icon—logging**—If the vehicle is logging, the implement icon appears as a green bar behind it.



**Vehicle Icon—logging (with all sections ON)**—If the vehicle is logging data from an implement split into sections, (for instance during a planting or application operation), then these sections appear in the implement icon.

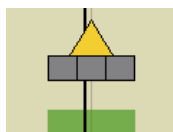

**Vehicle Icon—not logging**—If the vehicle is not logging data, then the implement icon appears as a grey bar.

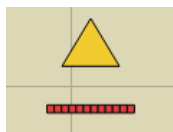

**Vehicle Icon—Master Switch Off**—When the master switch is off the vehicle will show a thinner red bar.

### Master Switch Status

This button shows if the Master Switch is on or off. It is toggled by a master switch or a switch box.



Master Switch Status - ON  
(GREEN)



Master Switch Status -  
OFF (RED)

**(O) AutoSwath button**—turns the AutoSwath feature on and off.



AutoSwath - ON



AutoSwath - OFF

**(P) Logging button**

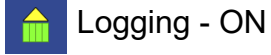

Logging - ON

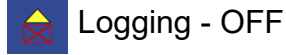

Logging - OFF

**AutoSteer button**

The Engage icon status of the AutoSteer system. The appearance of this icon displays the

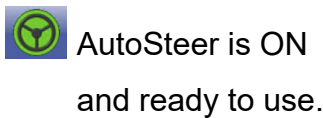

AutoSteer is ON  
and ready to use.

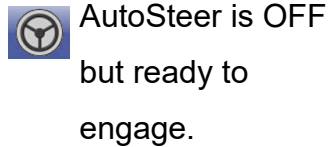

AutoSteer is OFF  
but ready to  
engage.

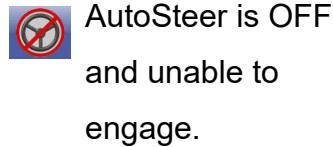

AutoSteer is OFF  
and unable to  
engage.

following:

**Map Legend tab**

Press the Map Legend button at the top of the Mapping toolbox, and the Legend appears, either for rate, coverage, seed monitoring, previous operations, or other.

**Map Toolbox**

**Legend Settings**

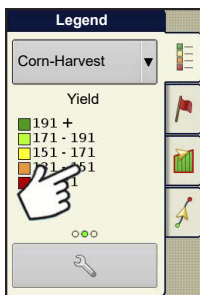

The Legend Settings screen allows changes the default legend. On the map legend tab, press anywhere on the legend and the legend settings screen appears.

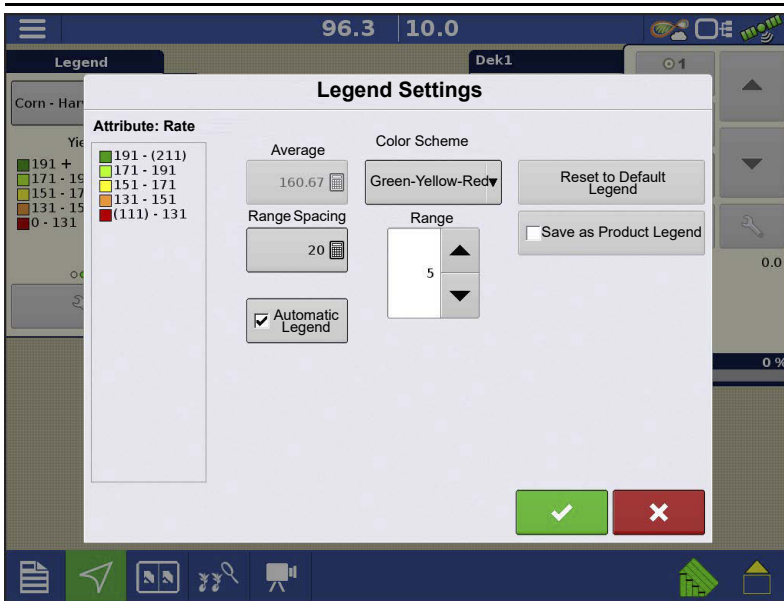

**NOTE!**

- The Legend Settings screen can also be accessed by pressing the Edit Legend button on the Setup screen's Product tab.
- Legend settings changes that are made at the Legend Settings screen will affect all regions.

The Legend Settings screen includes the following items:

- Attribute

Appears at the top left of the Legend Settings screen. Attributes shown for Harvest include Yield and Moisture. The Rate attribute is shown for Planting and Application operations. Adjust the color scheme, spacing and ranges as they appear on the map screen, by using the buttons described below.

- Average

The Average button changes the average rate for the legend. Press  to specify the average of the ranges shown on the map legend.

- Range Spacing

The Range Spacing button changes the difference between the rates in one color range. Press  to edit the legend range spacing value, which is the total number of units represented by a particular color.

- Ranges

The Ranges  /  change the number of range increments displayed in the legend.

- Color Scheme

The Color Scheme can be modified by using the drop-down list. Choices include the following:

- Green-Yellow-Red
- Single Hue (blues or greens)
- Rainbow

- Reset to Default Legend

Resets the legend to the default settings.

- Automatic Legend

If the Automatic Legend check box is selected, the average automatically sets itself to the field average and updates as the field average changes.

- Reset to Default Legend

Press the reset legend to the system default.

- Save as Product Legend

Select the Save as Product Legend check box to set the current legend as the default legend for all regions of the same product.

## Map Options

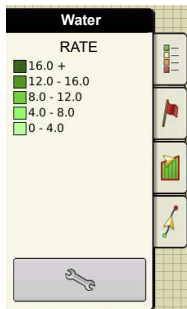

Toggle mappable items, load references, or follow selection. Press the Legend

Setup  and the Map Options screen appears.

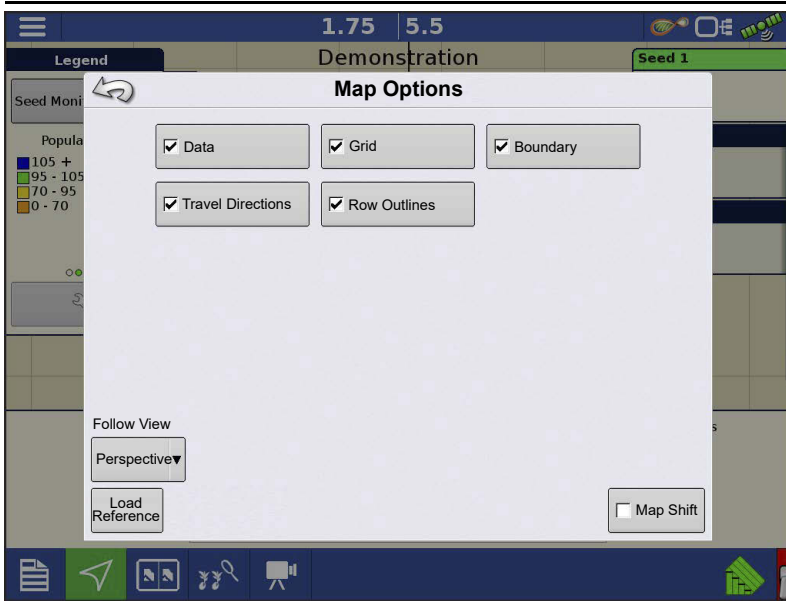

•Load Reference

Loads a list of maps of previous operations performed in that field. For each operation, view As-Applied or Coverage attributes; and Varieties if performing a Planting operation.

**Map Shift**



Map Shift is used to shift the onscreen map and account for time base inaccuracies with lower accuracy GPS receivers. This is done by doing a quick survey and creating a reference point. Any time the user would like to adjust the map to fix GPS drift inaccuracies they will go back to the reference point and perform a survey to shift to the current position.

**Map Shift General Guideline**

For Map Shift to be successful it is suggested that a reference point be set before beginning a field operation. That way any time the vehicle leaves the field or is shut down for an extended period of time the reference point can be used upon returning to the field operation.

**Enable Map Shift**



With the map shift option checked, the map shift icon  will become available when in full screen view on the mapping screen.

**Shifting the Map**





**Reference Point Set**

1. Press the map shift icon to access Map Shift Options.
2. Determine a good location to create a reference point. For Map shift to work properly it is vital that the GPS receiver be able to get back to the exact same point each time a shift is required.
3. Once a spot is located press “Set” on the Map Shift options page to begin the 10 second survey.

4. Once the survey is complete the reference point will be set. On the Mapping Screen the reference point is shown by the blue pin drop.

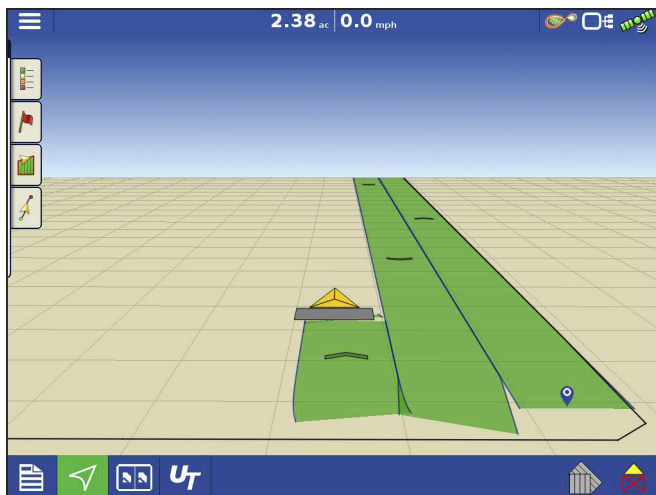

**Map Shift Needed**

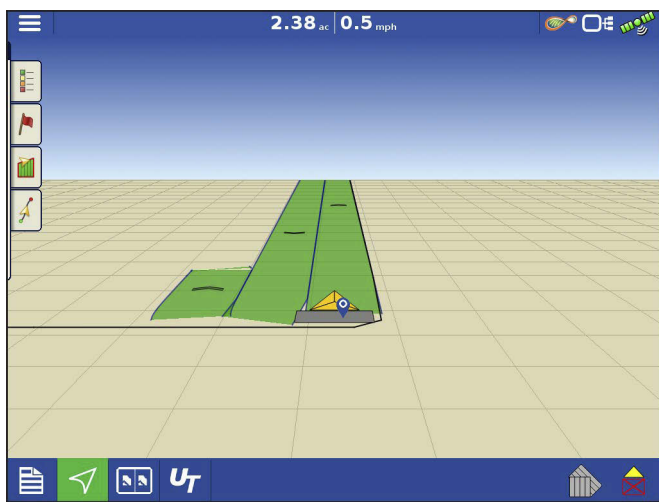

**Going Back to Reference Point**

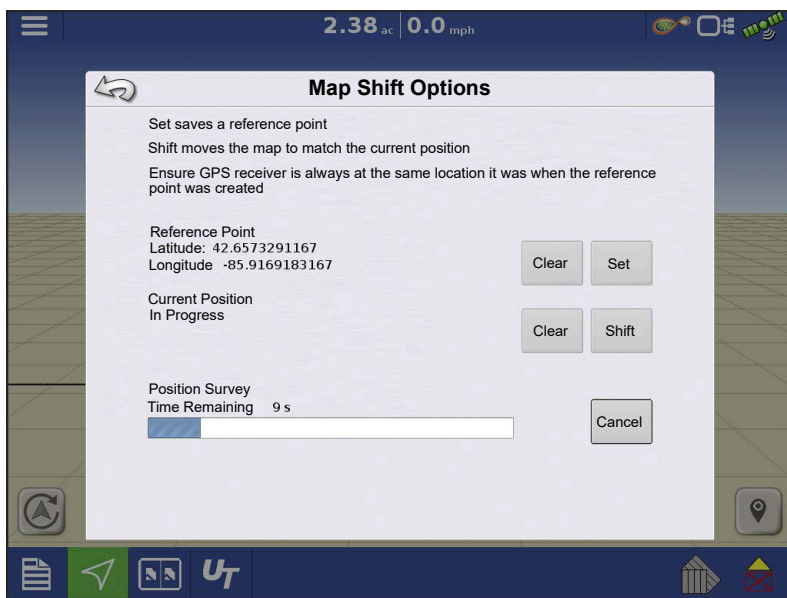

**Shifting Map**

5. When a map shift is required go back to the set reference point and make sure the GPS antenna is back in the original location.

6. Access the Map Shift Options menu and press the “Shift” button.

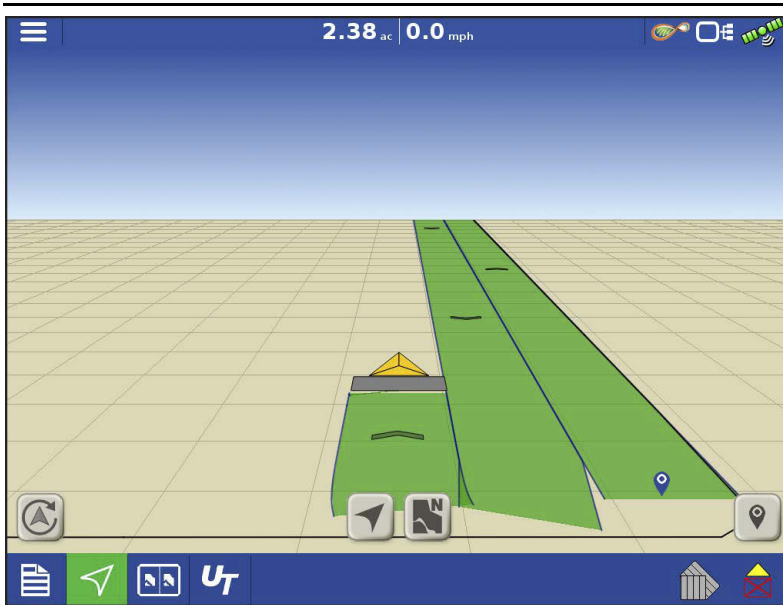

After Map Shift

7. "Shift" will start a 10 second survey and update the map with the new current position.

8. Any time a reference point or shift needs cleared it can be accomplished via Map Shift Options.

## Mapping Features

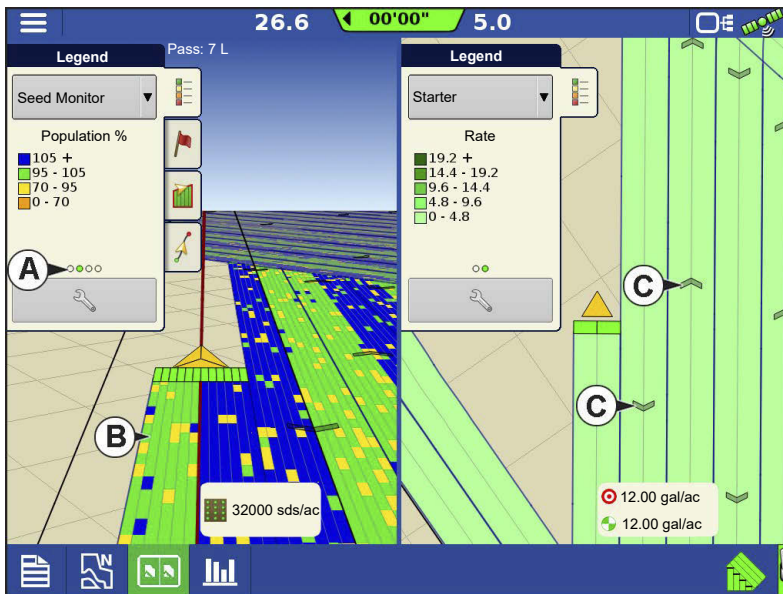

In a planting operation the InCommand 1200 display is capable of mapping information based on individual rows.

A. Dots in the legend indicate other attributes are available to map. Swipe to show different attributes.

B. Screen shows row by row mapping. Display shows and logs row by row planting attributes in any view when paired with Ag Leader Seed Monitor

Module.

C. Travel direction indicators automatically populate at intervals when operating. This feature can be toggled on/off in Map Options.

## Map Views and Split Screen

The InCommand 1200 has the capability of showing multiple views at the same time from the Mapping screen. This has multiple uses like showing guidance in Follow view and North Oriented view at the same time, splitting the screen between guidance and Universal Terminal, or watching two products at the same time like planting and liquid application.

- Maps can be selected individually from the legend drop-down **(A)**.
- Map view can be changed by tapping on the mapping icon **(B)** in the task bar.

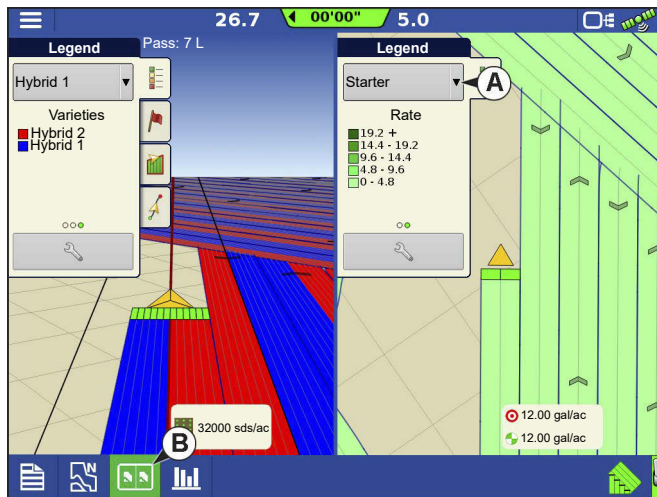
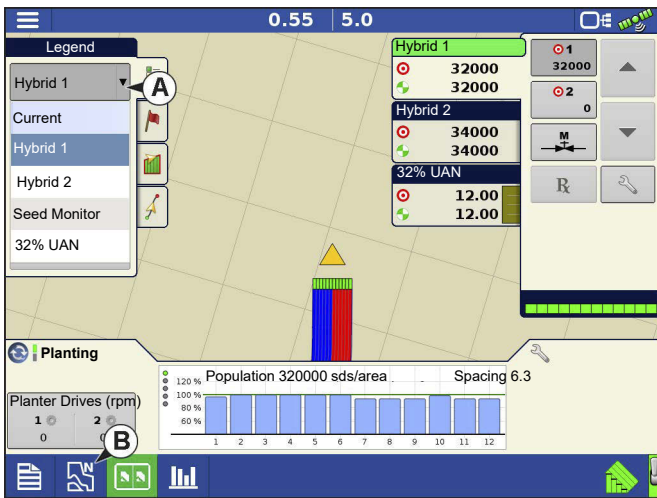

## Map Views

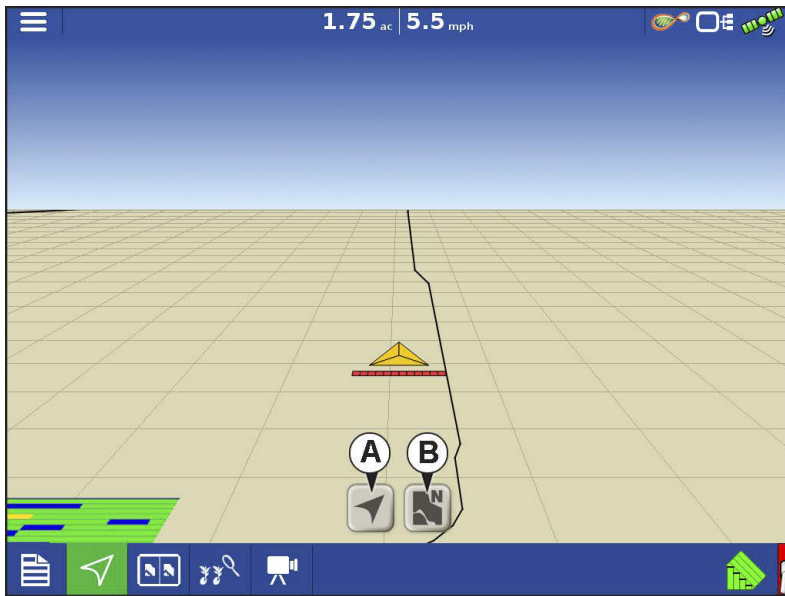

**Follow View(A)**—Sets the map to follow the vehicle icon. The default Follow View can be set to either Perspective view or Top-Down view

### Setting the Follow View mode

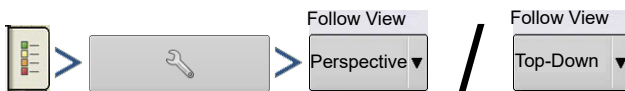

**North Oriented View(B)**—Zooms the map out to the full extends of the field boundary or mapped area and orients the map north regardless of the vehicles direction of travel.

### Zoom Devices View

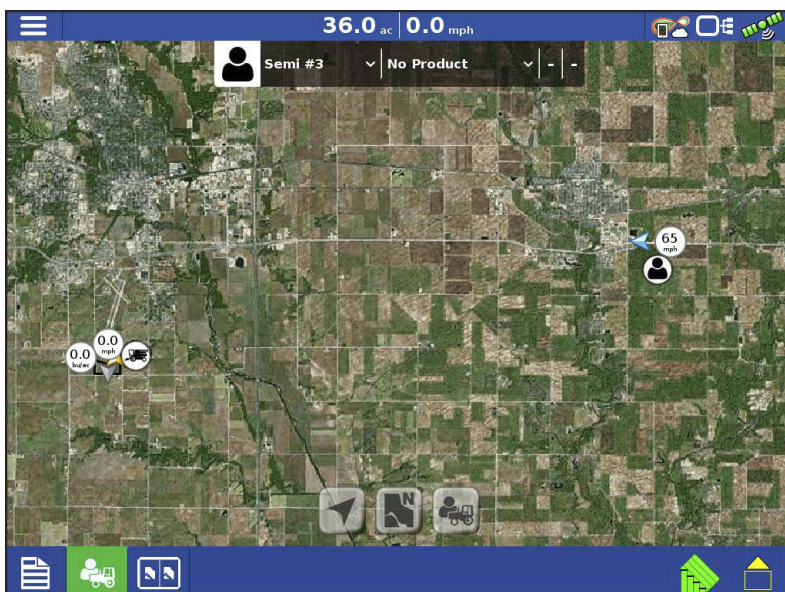

When this icon is pressed, all devices logged into AgFiniti (that have a GPS location and AgFiniti Essentials) will be shown on the display.

Button is only available when DisplayCast is unlocked.

If a user wants to see the location of other devices, they can press this icon and the map will zoom out to include the icons of other devices on that account, as well as their own icon.

Only devices within 60 miles of the display's location will be displayed when Zoom Devices is pressed. Vehicles farther away can be viewed but user must manually pan the map to find them.

No logged data will be displayed in this view.

## Zoom Devices in AgFiniti Mobile

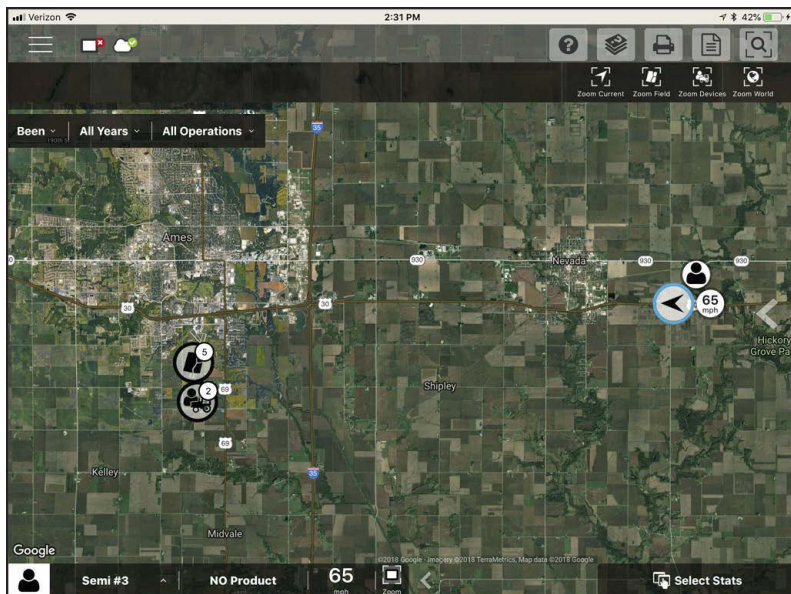

When this icon is pressed, all devices logged into AgFiniti (that have a GPS location and AgFiniti Essentials) will be shown on the display.

## Universal Terminal Split Screen

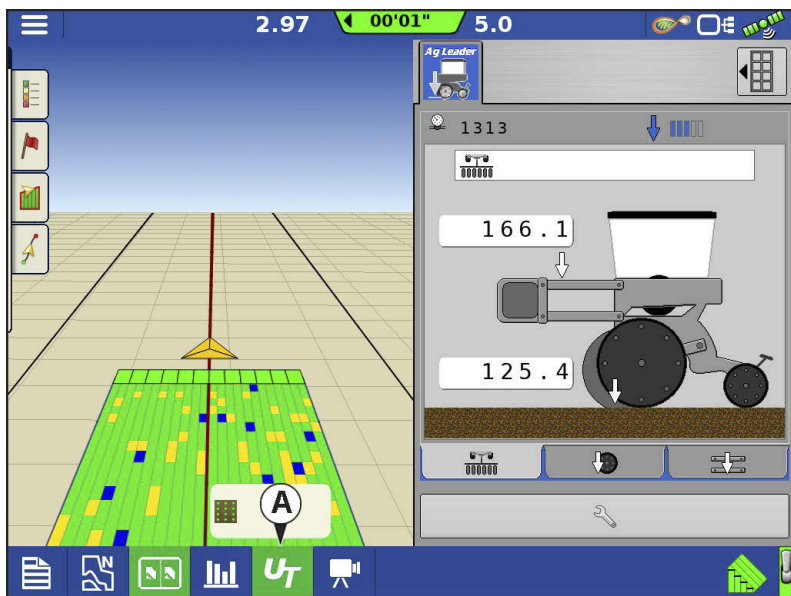

By pressing the UT button (A) from the map screen the display will split the screen between Map screen and Universal Terminal.

## Split Screen Advanced Seed Monitoring

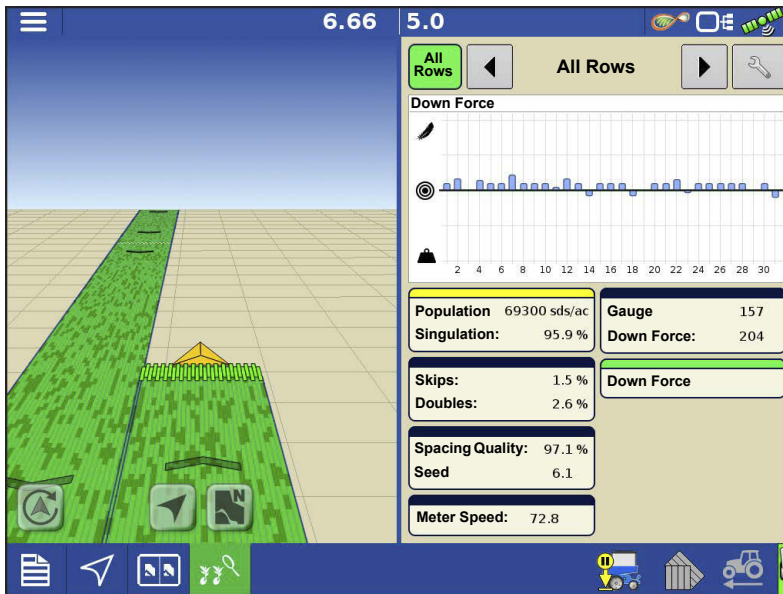

When using a Seed Monitoring Module, pressing the advanced seed monitoring button (A) will split the screen between the active map and the advanced seed monitoring page.

## Split Screen Video

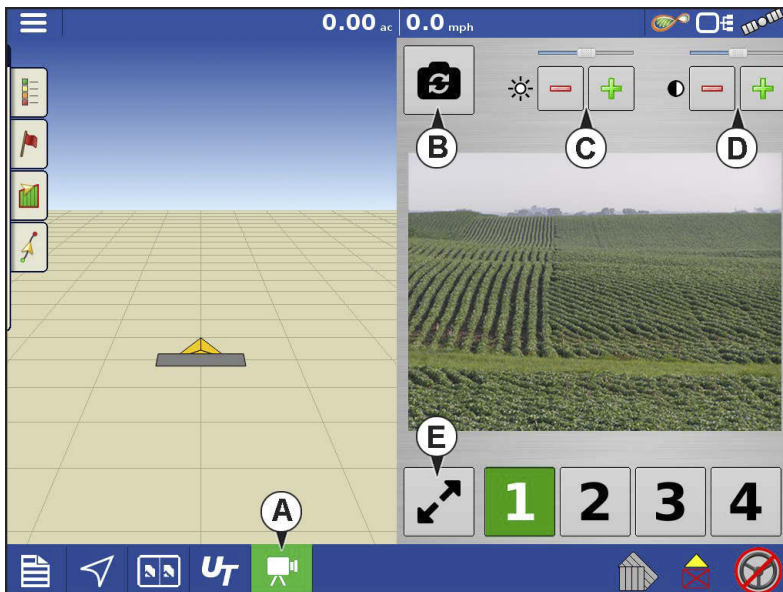

(A) With Cameras attached, pressing the video button will split the screen between the active map and the video page.



(B) Mirror Video Input



## (C) Brightness Adjust

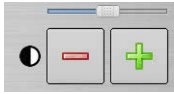

## (D) Contrast Adjust

## (E) Full Screen/ Split Screen selection



## Markers Tab

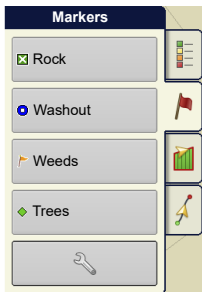

Markers are a collection of point objects that are available on the Map Markers tab of the Mapping toolbox. Map markers allow mapping points on the go in order to identify specific features within a field. Press an individual marker to indicate a Map Marker on the Map screen.

If all of the Markers created are not immediately visible in this screen, press the cycle button that will appear next to the marker setup button at the bottom of the marker toolbox.

## Edit Markers

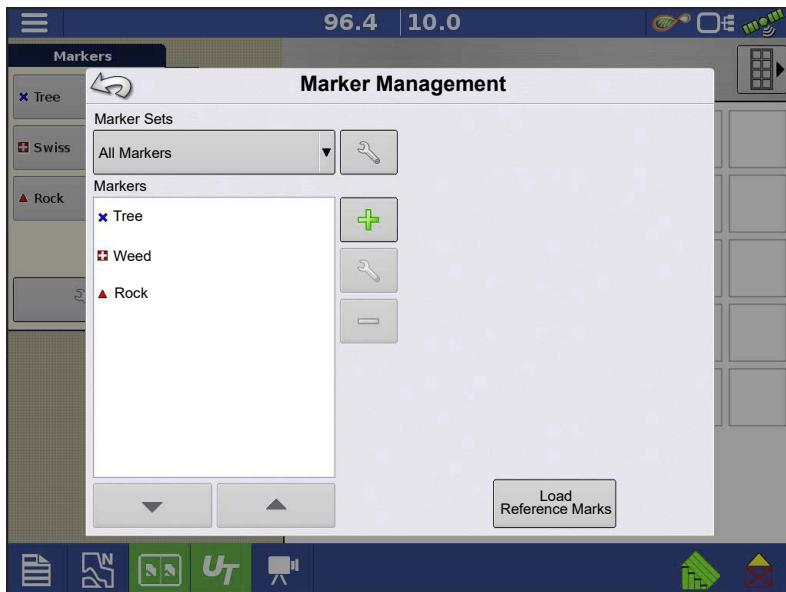

### Marker Sets:

Pressing  allows operator to create, name, and delete marker sets.

### Markers:

• Press  to add a marker.

• Press  to edit a marker.

• Press  to remove a marker.

• With numerous map icons, cycle

through them by pressing  / .

- When creating or editing a marker, check the Georeferenced note button to add a Field Note that is referenced to the current GPS position when that marker is used.



## Operator Selection



1. Press Select Operator button.

Select a machine operator from the drop-down list. Machine operator information is logged with all field operations. Operator information may be entered in Management Setup.

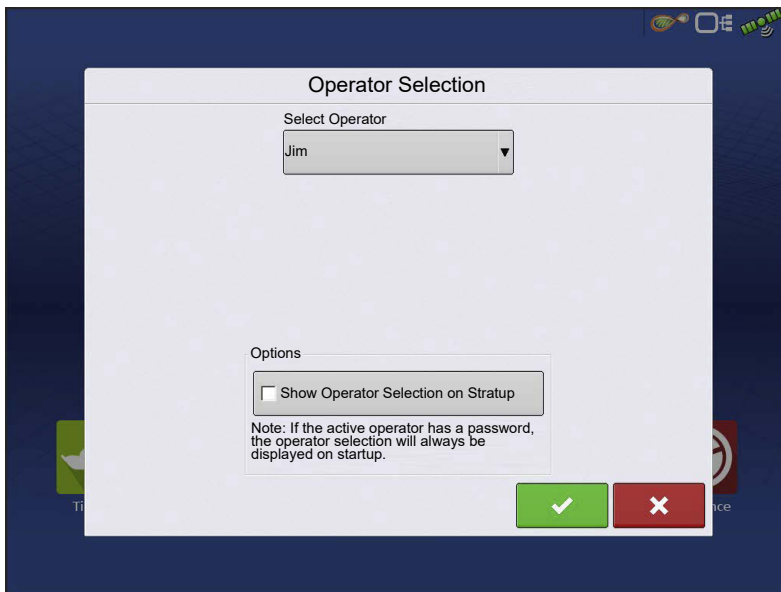

2. Choose the operator from drop-down menu.

**NOTE!** Checkbox will require a password to be entered upon start up of the display.

Press .

3. Enter password. Press .

The operator will now be selected and permissions active.

- If operator is changed in mid operation, the user will be prompted to continue or suspend event.
- Operator selection will show each time at startup if the “Show Operator at Startup” button is check-marked.

## Operator Log Out

Users that are both a Manager and Operator can logout which locks Setup and USB access and an operator must log in before an operation can be performed.

## Menu Buttons



 **Menu button**—Allows quick access the regularly used management and setup features without suspending an operation or leaving the map screen.



**Home button**—Suspends the current event and returns to the Home screen.



**Field button**—Used to change fields and events from the map screen. Takes user to the management selection portion of the Field Operation wizard.



**Product button**—Used to change products or hybrids in the middle of a field operation. Takes user to the product selection portion of the Field Operation wizard.



**Region button**—Used to subdivide a field into smaller sections. The region in which data is currently being logged is listed on the Region button. A new region can be created at any time while performing a field operation. To change between or add a new region to a field, press the Region button and follow the on-screen instructions.

## Event

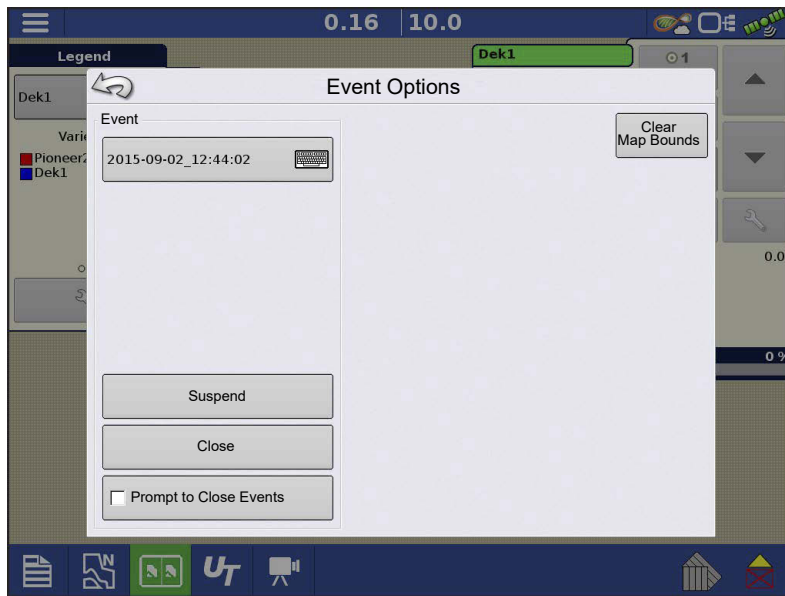

The Event Options screen allows operator to change:

- **Event Name**—Select the event to be edited in the drop-down menu. An active event will be preselected when the Event Options screen is opened.

- **Suspend Event**—Pressing this button suspends the current field

operation. The Home screen then appears as before the creation of a field operation.

- **Clear Map Bounds**—Press to clear map bounds for the selected event.
- **Close Event**—Pressing this button ends the current field operation. The Home screen then appears as before the creation of a field operation.

A closed event cannot be re-opened and will not show up in the Event Selection screen. A user can manually close Events or be prompted to close events.

- **Prompt to Close Events**—Check this to be prompted before an event is accidentally closed.

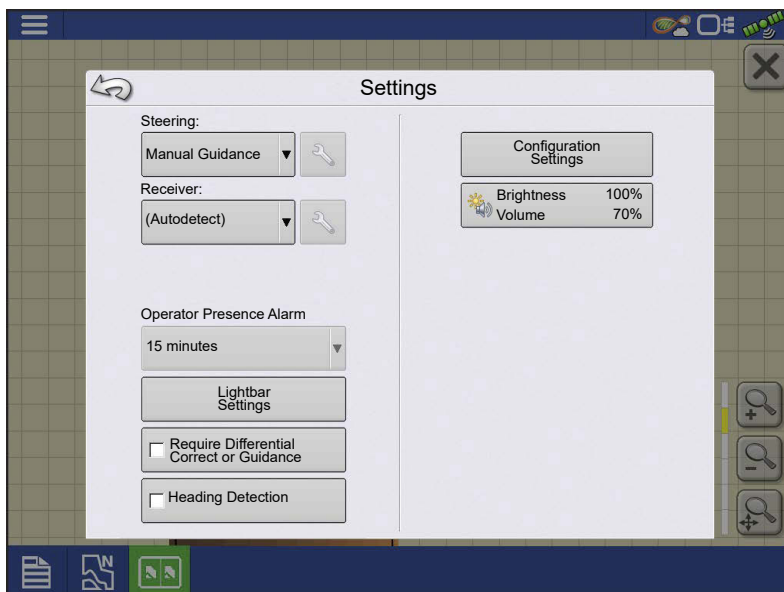

Settings button—provides quick access to:

- GPS settings
- Steering settings
- Lightbar settings
- Configuration settings
- Brightness/Volume
- Heading Detection



## Automatic Swath Control

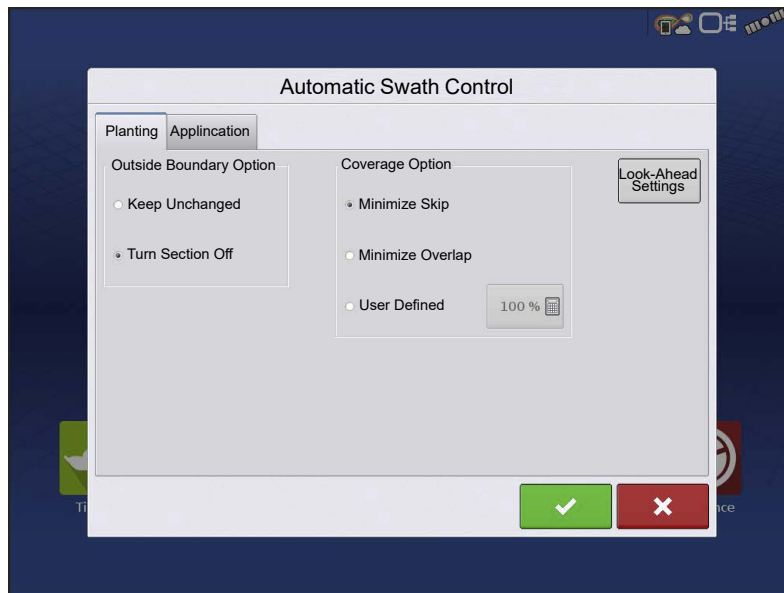

The Automatic Swath Control feature turns sections off and on automatically based upon the following conditions:

- Entering and exiting internal and outer field boundaries.
- Entering and exiting previously-applied areas within a field.

Automatic Swath Control can be toggled on/off by the AutoSwath button on the lower right-hand side of

the Map screen.

To adjust AutoSwath settings, go to the Configuration Settings screen, press the Automatic Swath Control button. At the screen that appears, options are:

- **Outside Boundary Option**

Select one of the two options to determine system behaviour when a section exits a field boundary.

- **Coverage Option**

In the Coverage Option area, choose between three options:

- **Minimize Skip**

Turns off the implement section after the entire section is fully inside coverage area.

This prevents the possibility of skips.

- **Minimize Overlap**

Turns off the implement section when that section first enters coverage area.

This prevents the possibility of overlaps.

- **User Defined**

Choose what percentage of the implement section is within the coverage area before that section turns off. For example, choose 50%, then the section will switch off when half of it is within coverage area.

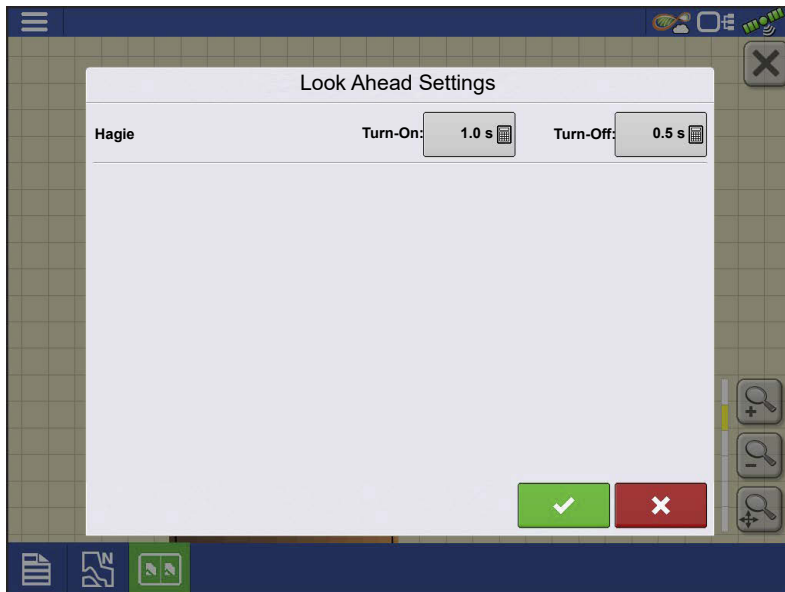

#### •Turn-On Look Ahead

Determines how far ahead the system looks to turn the sections back on. This compensates for delay in the system when the implement sections are turned on.

#### •Turn-Off Look Ahead

Determines how far ahead the system looks to turn the sections off. This compensates for delay in the system

when the sections are turned off.

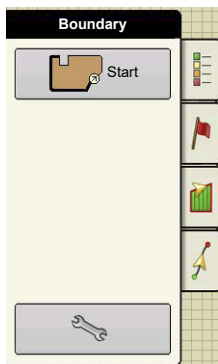

## Boundary Tab

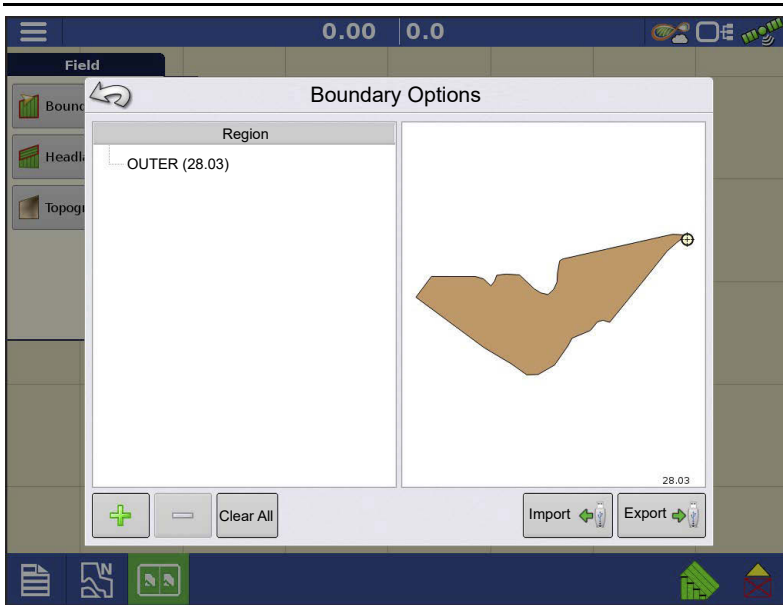

Press the Boundary button on the Field tab to access the Boundary Options screen.



Use the Boundary Options screen to Import Boundaries, Export Boundaries, and Clear All Boundaries.

- Pressing  on the Boundary Options screen opens the Boundary Settings screen.
- Highlighting an existing region and pressing  on deletes that region.
- Use Import and Export buttons to move regions to and from USB drive.

- Press Clear All to permanently delete all Boundary information for that field.



**WARNING!:** Once cleared, this information cannot be retrieved.

## Create Boundary

### Boundary Settings

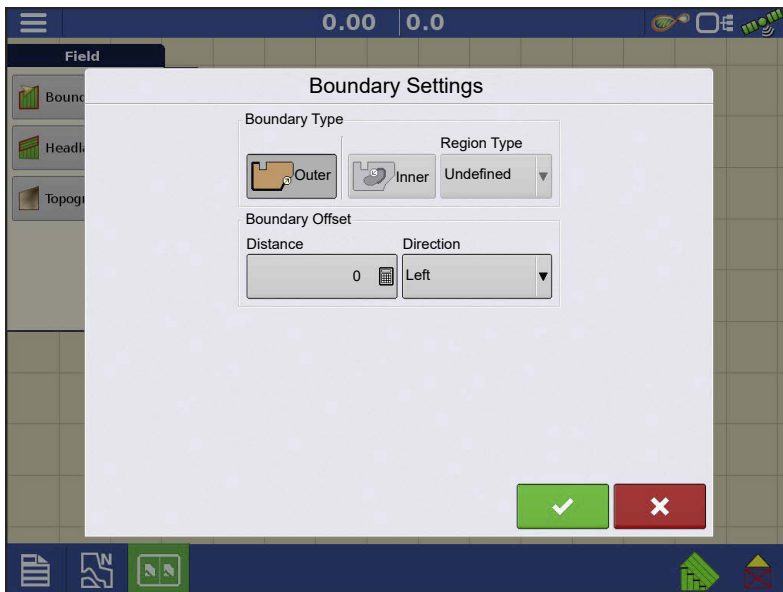

Pressing the Start button opens the Boundary Settings screen.

Underneath the Boundary Type, choose either an Outer Boundary or an Inner Boundary.

- Outer boundaries delineate the borders of an entire field.
- Inner boundaries mark specific features within that field, such as waterways or buildings.

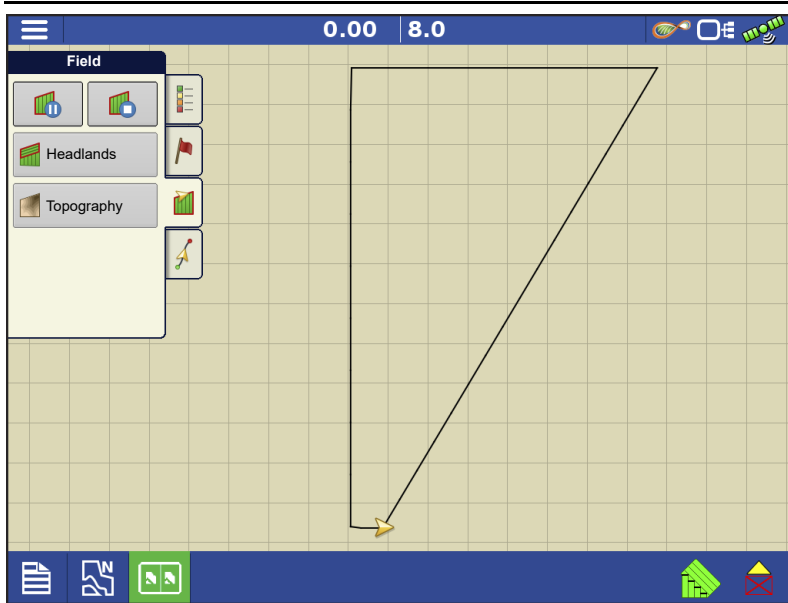

1. Choose whether to create either an Outer boundary or Inner boundary by pressing one of the two Boundary Type buttons.

2. To create an Inner Boundary, use the Region Type drop-down menu to choose the type of boundary. Choices include:

- Roadway
- Body of Water

- Waterway
- Buildings
- Undefined

3. The Boundary Offset feature enables mapping a boundary at a user-defined distance to the left or right of the GPS antenna center line. If desired, specify a Boundary Offset distance by choosing a direction and distance from the GPS antenna center line.

4. Press  to start the boundary.



5. During the creation of a boundary, the Pause/Resume button and Stop button appear at the top of the Field tab.

6. Press the Stop button to complete the boundary. At the Boundary screen, choose whether to Save, Resume or Discard the boundary.

### Pause Boundary

When creating a boundary, use the Pause Boundary button to create a straight line between two points. To do this, drive the vehicle to a point, press the Pause Boundary button, then drive to the second point. Press the Resume Boundary button to create a straight line between current point and pause location.



## Headlands



Press the Headlands button on the Field tab to access the Headlands Options screen.



**ATTENTION!** A Field Boundary is required to create a headland.



**ATTENTION!** For headland alarms to work, a guidance line must be loaded.

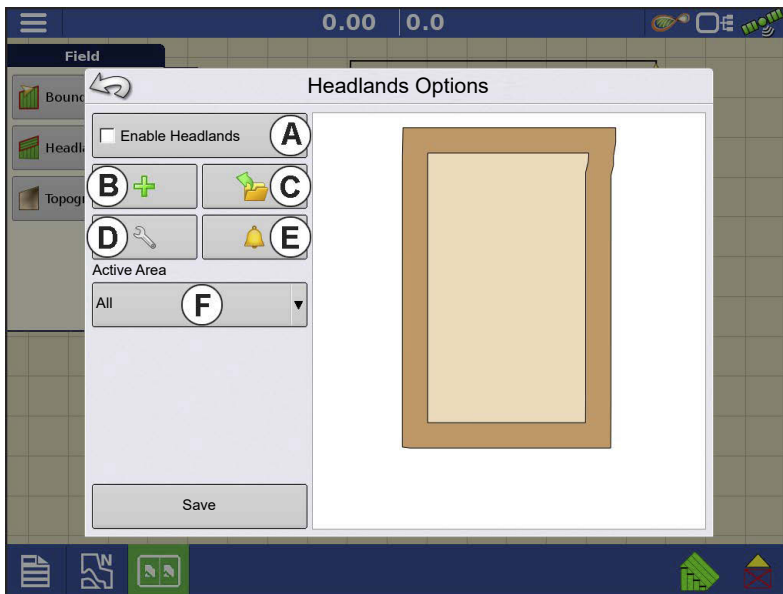

A. Enable Headlands: Use checkbox to turn Headlands functionality on and off.

B.  Add Headland

C.  Load a Headland

D.  Edit Headland

E.  Alarm Settings

F. Active Area

---

## Active Area

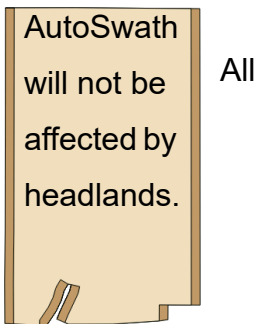
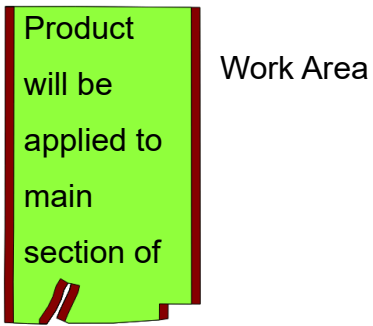

## Add a Headland

Press  on Headlands Options screen.

Select Headland Type from drop-down box.

## Headland Types

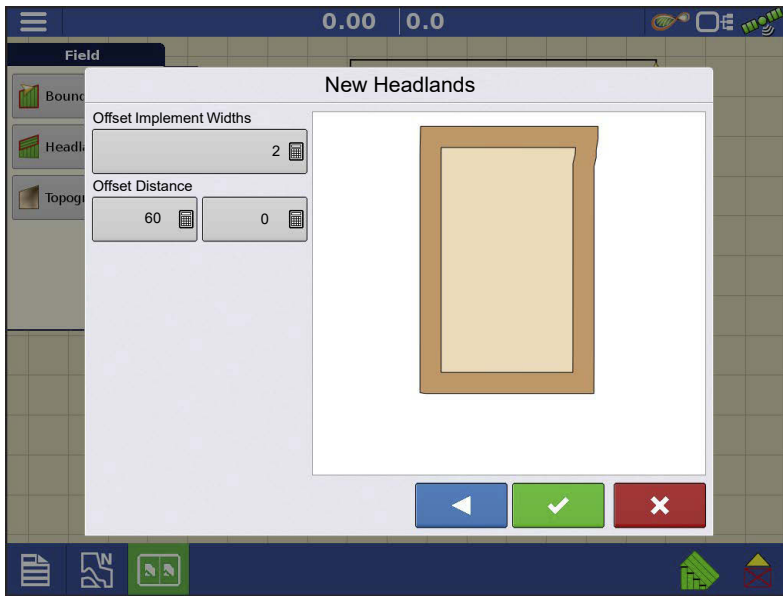

### All-Around

- Offset Implement Width

Number of implement widths used to set the headland width.

- Offset Distance

Distance used to set headland width.

Press  to accept.

### Top Bottom

- Offset Implement Width

Number of implement widths used to set the headland width.

- Offset Distance

Distance used to set headland width.

- Heading

Used to generate boundary, headlands are created perpendicular to heading

- Scaling

Sets the amount of variation that is allowed (from perpendicular) to include part of field boundary in the headlands.

- Use AB



Select AB line to set heading for determining headlands.

- The  shows the heading used for Headland creation.

Press  to accept.

### Driven

1. Select Driven from drop-down menu and press  to continue.



2. Press  on New Headlands screen.
3. Input Headland Offset Distance and Direction (Left or Right). Press  to accept.
4. Drive Boundary:

 pause.

 resume recording after pausing.

 stop recording.

#### 5. Save, Resume, or Discard

- Save
  - a. Press Save button.
  - b. Default name is time and date. Press  to change name.
  - c. Press  to accept or  to discard boundary.
- Resume - resume creating boundary.
- Discard - discards boundary and returns display to map screen.

## Load Headlands

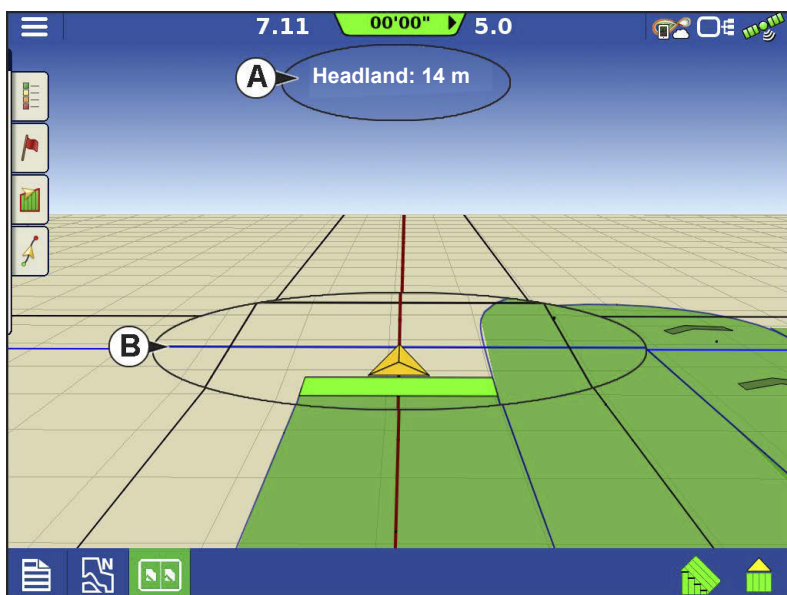

Press  button.

Select a headland from list. and press

 to load selected headland.

A.Distance to headland alarm

B.Headlands identified by blue line when active

## Edit Headlands

Press Edit Headlands button.

Select a headland from list and press  to load selected headland.

This screen will vary depending on type of headland.

## Headland Alarm Settings

Press  button.

- Alert Distance

Distance from approaching headland at which display will warn user of upcoming headland.

- Alert Duration

Time length from approaching headland at which display will warn user of upcoming headland.

- Audible Alarms
  - Approaching Headland.
  - Crossing Headland Boundary.

## Topography

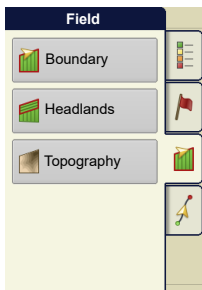

Press “Topography” button to enter the Topography screen which allows user to setup Topography functionality.

Record points that can be used to make a reference layer that is relative to the elevation throughout the field. This can provide valuable information in regards to the highs and lows of a field when it might not be visually apparent. Surveying and Tiling operations will probably benefit the most with respect of where to place the mains and laterals in a field.

Import data from mapping software such as SMS™ Advanced via .agsetup files.



**ATTENTION!:** Requires RTK GPS signal to collect the accurate elevation data.

---

## Topography Screen

Multiple topographical elevation surveys are allowed for the same field. This can be useful for different applications, for example:

- One topographical survey that is for the entire field. This will give a greater perspective of the whole field.
- An additional topographical survey, driven at very dedicated portion of the field. This would allow a greater elevation detail in certain areas if needed.

By default the naming that is generated in the display will be Date/Time based. Export surface elevation data from software packages like SMS Advanced into the display, and those will be tagged with the field name and the date exported (both examples are in the screen shot).

Add points to existing topographical surveys and save them.

Only one topographical survey can be active at a time. When exported as an .agsetup or .agdata file, this will be the survey that is exported. Non-active surveys will stay in the display. At any time, remove a topographical survey, and collect a new one.

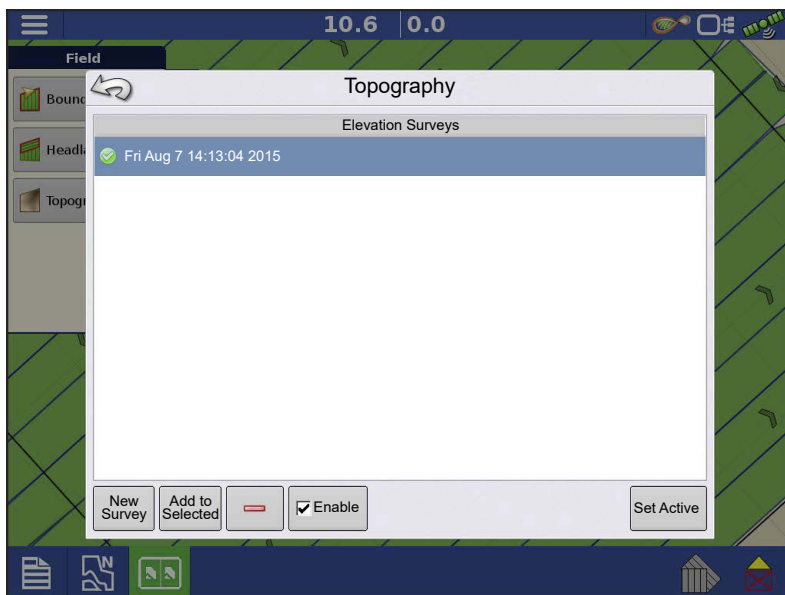

•New Survey button

Press to create a new topographical survey

•Add to Selected button

Press to add to an topographical survey

•Minus (-) button

Press to delete a topographical survey

•Enable checkbox

Press to turn topographical reference layer on/off (Enable checkbox functions the same as Topography checkbox in Map Options screen - shown below.)

- Set Active

Select the desired topographical survey from list and use button to set as active.

# In-Field Functions

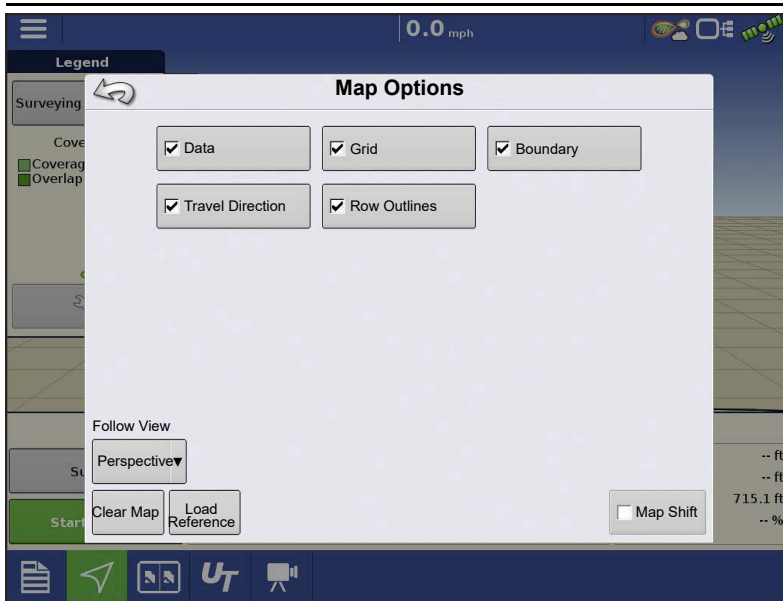

The topography layer can be turned on/off as a reference layer during any operation using:

- Enable checkbox on Topography screen (shown above).
- Using the Topography checkbox on the Map Options screen.



RTK GPS reception will allow collection of an elevation survey. This will allow collection of the Latitude/Longitude and elevation values as field is traversed.

A point will be dropped every 10 ft regardless of speed, or direction. If collecting during operations like planting or application using autoswath, it will also log points outside the boundary of the field (i.e.

through a grassed waterway) to get the most information throughout the field.

During collection of an elevation survey, points will be logged to the file every 10 ft. An on-screen visual will appear in the form of a single black dot (**A**) every 100 ft.



**ATTENTION!:** It is critical that the GPS Antenna to ground measurement is correct, any error in this measurement, will add to the error in the data logged.

The following are suggestions to get the best possible elevation survey for a given field.

Following these recommendations for best results.

- Keep swaths in the field to 62 ft or less, the closer the better.

- Driving a dedicated route at the lowest or highest points in a field (i.e. lengthwise of a grassed waterway, or at the top of a ridge) then traversing the field in regular swaths will provide the best detail of the field.
- If surveying with the tile plow antenna, ensure that the plow is in the fully raised position.
- Driving too fast with mounted plows, can cause bouncing and affect quality.
- Surveying with harvesting equipment can provide streaked maps as the hopper filling and unloading can affect the height of the vehicle, and therefore antenna.

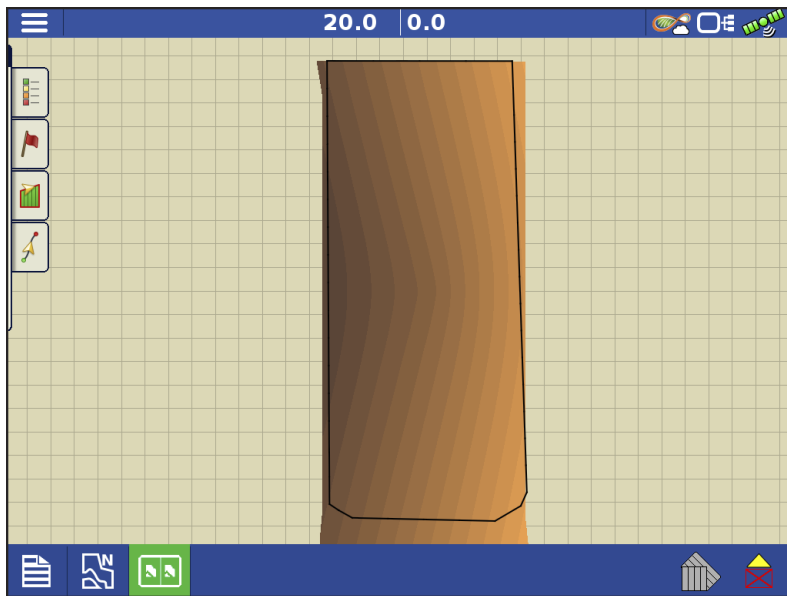

After the survey points have been collected, they will be converted into a surface layer. Define the color scheme Red, White, Blue, or Brown-Tan.

Select the number of legend ranges for field that will show the areas desired. This theme will be used for each field until changed.

Hues will represent:

### **Red, White, Blue Scheme**

Darker blue = Lower elevation.

Darker red = Higher elevations.

White will be a transition color between.



### **Brown-Tan Scheme**

Dark brown = Lower elevations.

Tan = Higher elevations.

If at any point during collection GPS correction status changes out of RTK fixed, logging will be suspended.

If RTK signal is re-acquire, logging will automatically resume.

 (pause) or  (stop) collection of the elevation survey at any time, and then  (resume) as needed.



If logging while leaving the field, a message will prompt that data collection is still active, and an option will be given to continue logging, or end operation.

In Odd-shaped fields, the surface rendering of the elevation will connect areas even if that area hasn't been driven through.

### Satellite Imagery

Satellite Imagery is a free online Service that any user with an AgFiniti® account (no license required) and internet access on an InCommand™ v1.5+ display can utilize. Each time a field is loaded to the Mapping Screen the satellite image for the field and surrounding area is downloaded and displayed. Approximately 4.5 MB of data is used each time the Mapping screen is loaded.

### Satellite Imagery Requirements

1. AgFiniti account created at [www.agfiniti.com](http://www.agfiniti.com)
  - a. AgFiniti accounts are free to create and no license is required.
  - b. Logging into AgFiniti.
2. Active internet connection on the InCommand Display
3. Field Boundaries—not required for firmware version 4.0 and newer.

### Enabling Satellite Imagery



Satellite Imagery is enabled by default. To enable/disable this feature check/uncheck “Satellite Imagery” in the AgFiniti Console Setup menu.

## Satellite Imagery on the Mapping Screen



When the above requirements are met, log into AgFiniti on the display. The satellite background image is downloaded automatically each time a field is loaded to the Mapping Screen. If needed, the satellite image may also be hidden via the Map Options Menu. See “Map Options” on page 111.



North Oriented view

(shown to right)

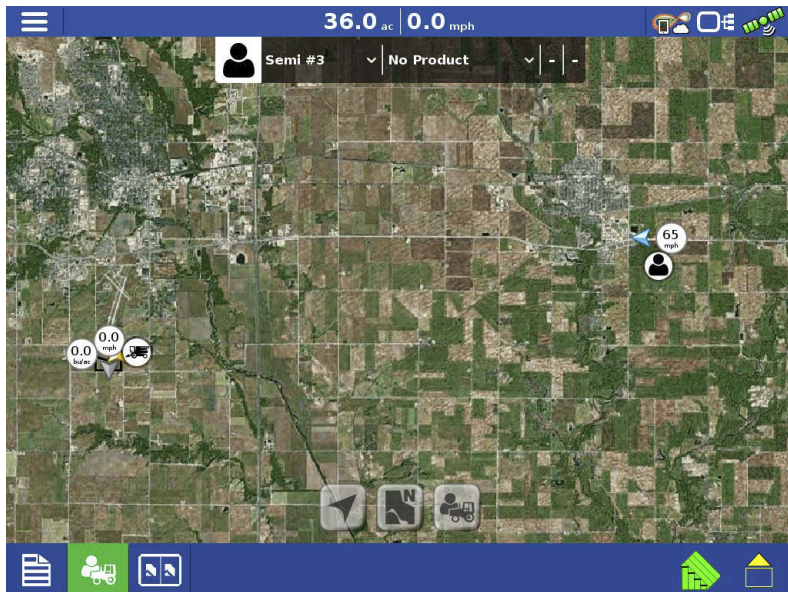

In the Zoom Devices view (shown to right) an operator can zoom out to a large area, as compared to the North Oriented view (shown above). Operator can also pan the map over large distances in Zoom Devices view. Data usage can vary in this view depending on how often the operator is using it.

## GPS Setup

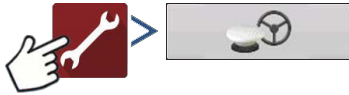

## Steering



**Manual Guidance**—Select this to perform guidance by lightbar while manually steering the vehicle.

**ParaDyme/GeoSteer**—Integrated steering system that can be used with a wide range of machines.

**OnTrac3™**—Assisted steering that is mounted on a machine's steering wheel.

**SteerCommand®**—Integrated steering system that can be used with a wide range of machines.

**SteerCommand Z2/SteadySteer**—Integrated steering system that can be used with a wide range of machines.

Pressing  next to the Steering options opens the guidance system settings for the selected guidance system.

Pressing  next to the Receiver options opens the selected receiver's specific settings.

Populated settings vary from one reliever model to the next.

- **Receiver**—Set type of GPS interface protocol to Autodetect, Serial, or CAN.

 • **Break Detection**—Opens force GPS connection. This allows force connection in the display when a receiver is set to a higher baud rate than supported by the display. After selecting “force connect”, user must select reset to defaults in order to configure and use the receiver.

- **Operator Presence Alarm**—The Operator Presence Alarm disengages guidance control if the operator does not have any interaction with the display for a specified period of time. Use the dropdown menu to specify the period of time before guidance is automatically disengaged.
- **Lightbar Settings**—Set lightbar spacing, mode, and LED brightness.

- **Required Differential Correction for Guidance**—When unchecked allows guidance to operate without differential correction.



**NOTE!:** In order to use guidance with the display, GPS receiver must be capable of a GPS output rate of 5 Hz or more.

## Lightbar Settings

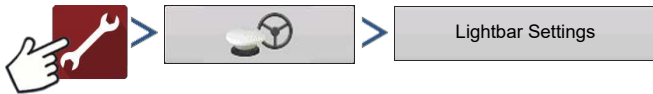

OR

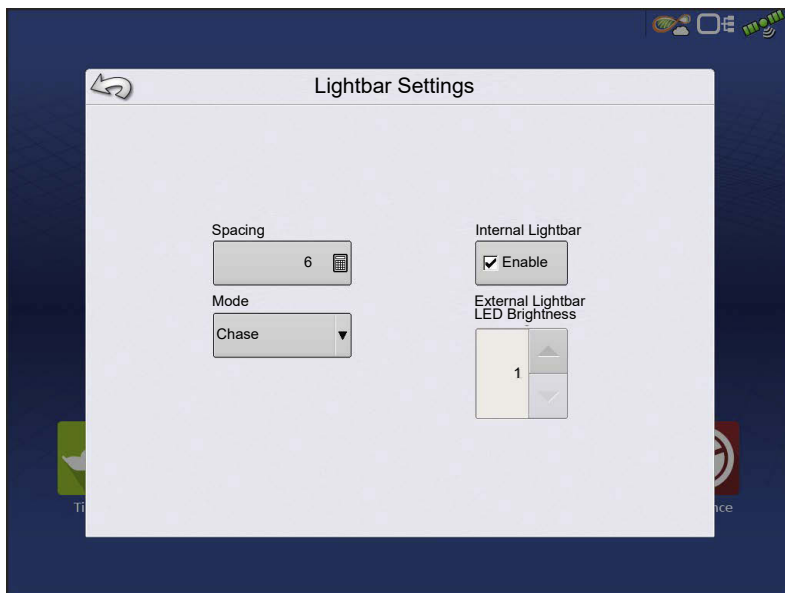



**Spacing**—Enter the distance represented by each square of the lightbar ½–6 ft (3–182 cm).

### Mode

- **Chase**—Center the vehicle by following the indicator lights.
- **Pull**—Center the vehicle by turning in the opposite direction of the indicator lights on the lightbar.

**Internal Lightbar**—Check Enable to utilize the internal lightbar.

**External Lightbar LED Brightness**—If applicable, press  /  to enter in a number specifying the brightness of the LED lights on the optional L160 external lightbar. The number 1 is the dimmest setting and 10 is the brightest. Default setting is 5.

## GPS Button



During field operation, the GPS (Status Indicator) button in the upper right-hand side of the Status Bar should appear green, which means display is receiving a differential GPS

signal. If this icon appears yellow, system is receiving GPS but are not receiving a differential signal; and if it appears gray, GPS is lost. In either case, check GPS settings.

Guidance/Steering, Lightbar Settings, and Required Differential Correction for Guidance.

## Serial GPS Settings

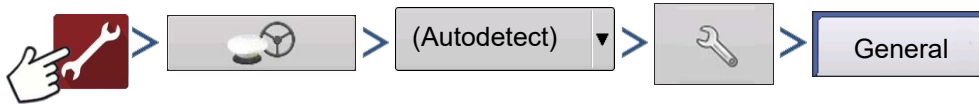

**NOTE!:** Default settings for the 6000/6500/7500 receivers should not need to be adjusted from factory settings.

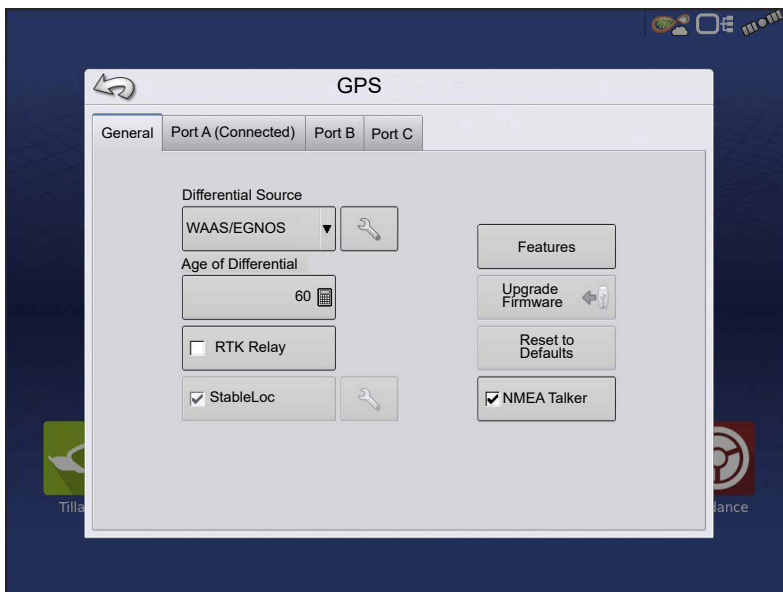

**Differential Source**—Select choice of GLIDE, WAAS/EGNOS, TerraStar®, RTK External, RTK. Options available are based on receiver type and unlocks.

### Differential Source Wrench Icon



—Pressing the Differential Source Wrench button opens different settings screens, depending on the differential source selected.

**Age of Differential**—Displays the elapsed time since reception of last differential correction signal. The Age of Differential button is only functional when GPS is connected.

**RTK Relay**—Check button when using a 7500 RTK relay. Receiver will reboot and change settings to look for the relay. Port C will be hidden when this is enabled.

**StableLoc® checkbox**—StableLoc maintains accurate steering – even when correction signal is temporarily lost – by seamlessly transitioning to the next available signal source. When the signal is restored, the system will then transition back to the higher accuracy source, eliminating position jumps. Press to enable.



**NOTE!:** StableLoc is enabled by default when WAAS/EGNOS is selected and cannot be disabled by the user. Operating WAAS/EGNOS with StableLoc enabled provides similar or better accuracy than operating with WAAS/EGNOS with StableLoc disabled.

**Reset to Defaults**—Press the Reset to Defaults button to restore receiver settings to the factory default. This will remove all custom settings.

**NMEA Talker**—This button disables the GLONASS prefix in the NMEA messages. If using the GPS receiver with legacy displays or a device that does not support GLONASS messages, uncheck the box.

## WAAS/EGNOS Settings

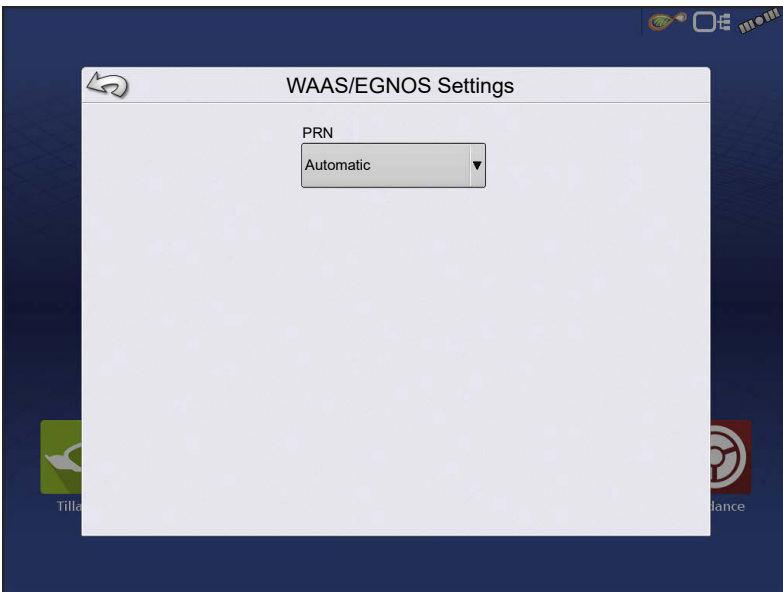
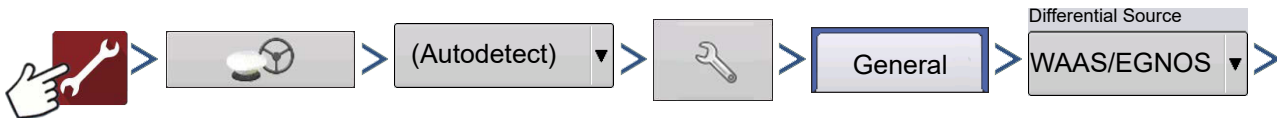

### PRN

- Automatic
- WAAS
- EGNOS
- Custom



**ATTENTION!:** Should be left on Automatic unless otherwise told by support.

## TerraStar Settings

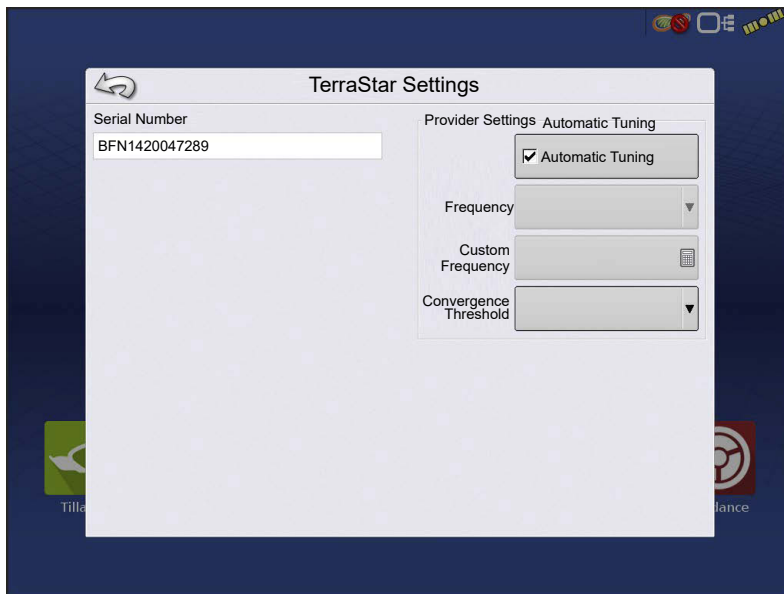
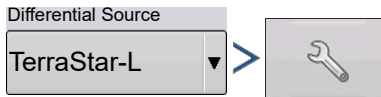
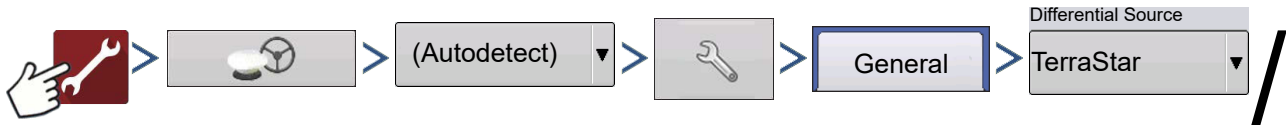

**Serial Number**—This box shows the serial number of the receiver - used to purchase TerraStar subscription.

**Automatic Tuning check box**—Receiver will automatically select the strongest frequency. Frequency drop-down box will be grayed out when this is selected.

**Frequency**—In the Frequency drop-down list box, select current geographic region. Only uncheck

automatic tuning when directed to by Technical Support (used to adjust tuning).

**Custom Frequency**—User entered TerraStar frequency. Only enter custom frequency when directed to by Technical Support.

**Convergence Threshold**—The receiver uses the standard deviation of the solution to determine when the TerraStar position has converged. The receiver will label the TerraStar solution as “converged” when the horizontal standard deviation reaches the Convergence Threshold setting. Relaxing the convergence threshold shortens the time before a TerraStar solution is reported as converged. However, it does not alter the absolute behavior of the solution.



**NOTE!** The use of TerraStar® differential requires purchase of a subscription from an Ag Leader dealer. Settings related to using satellite differential correction vary based upon

geographic location. Setup details are explained on the following pages. More specific information can be obtained through an Ag Leader dealer. Know the serial number when contacting Ag Leader to set up the receiver.

## RTK Settings

### RTK Settings - NTRIP External

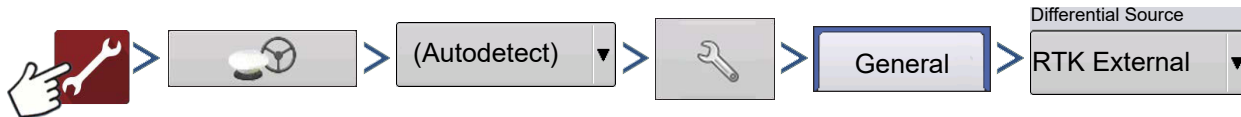

Set GPS 6500/7500 to “RTK External” when using NTRIP RTK on InCommand or when using external radio for RTK correction.

### RTK Settings - NTRIP RTK on InCommand

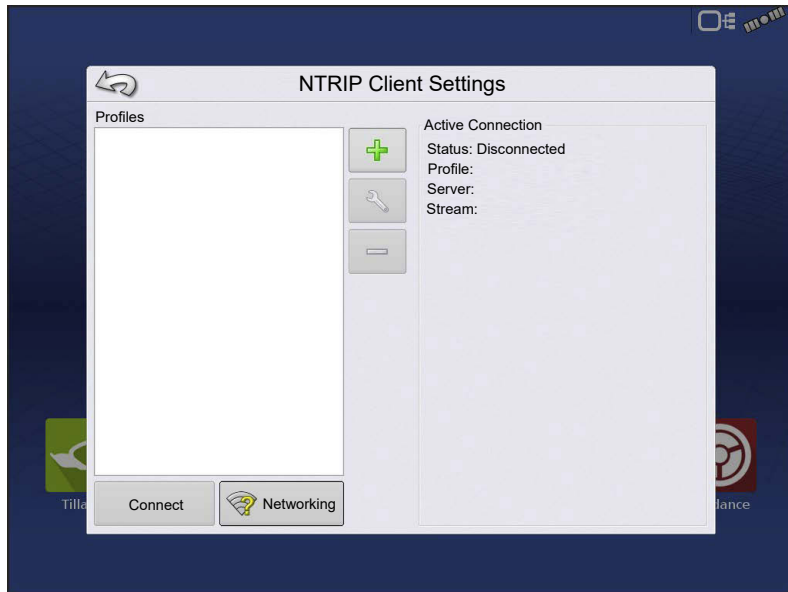

 Create profile

 Edit profile

 Delete profile

 Networking Access wireless

Networking

 Connect to NTRIP

Stream

 Disconnect from NTRIP Stream





**NOTE!:** Display must be connected to network/hotspot with active internet connection before a profile can be created.

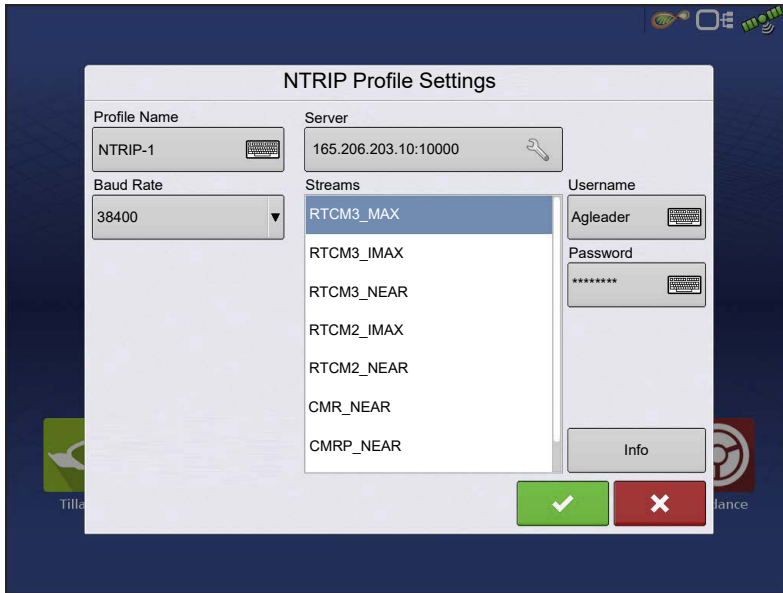

When creating or editing an NTRIP profile, the following information must be entered in the InCommand display:

1. Profile Name
- User Specified
2. Baud Rate
- GNSS receiver specific
3. Server
4. Streams
5. Username

6. Password



**NOTE!:** The information for items 3-6 is obtained from the NTRIP Network Provider.

Once the information has been entered, press  to begin using NTRIP.





**Info button**

- Stream
- Format
- Format Details
- Navigation System
- Network
- Authentication

The information shown on this screen is provided by the NTRIP Network.

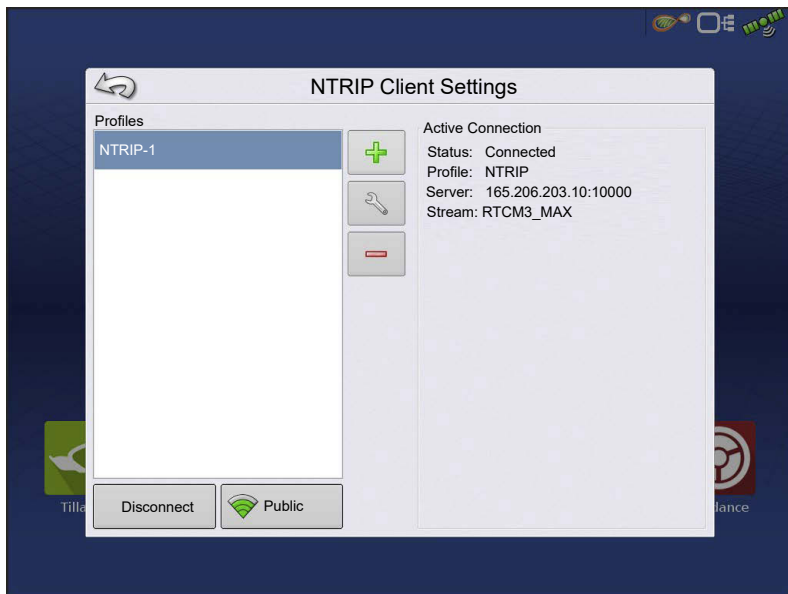

When successfully connected to NTRIP, network stream status will update under “Active Connection”.

**i** **NOTE!:** NTRIP Profiles can be used to seamlessly change between NTRIP Streams.

**RTK Settings - NTRIP Relay (GPS 6500 Only)**

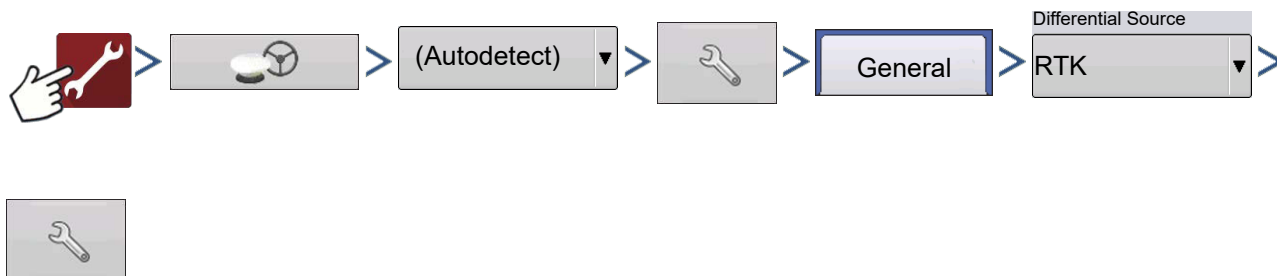

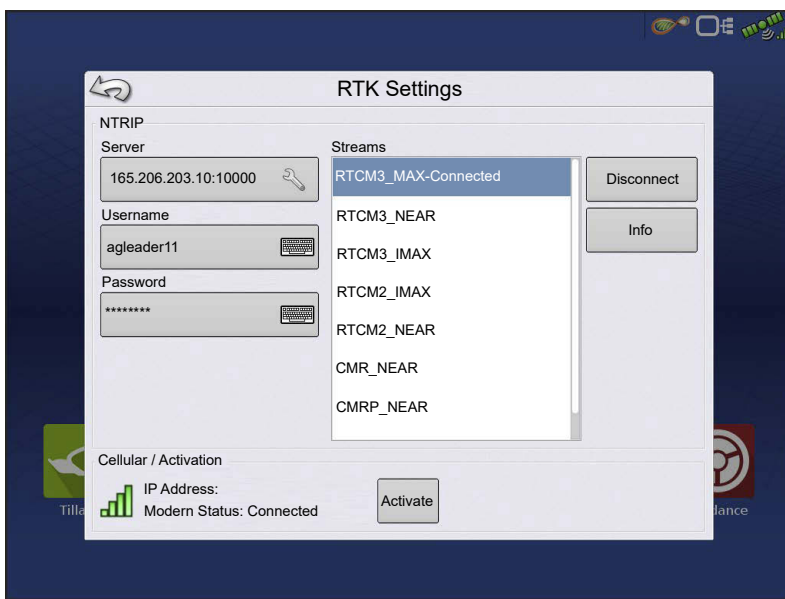

## NTRIP

- Server
- Username
- Password
- Streams
- Disconnect/Connect - to the NTRIP Network
- Info - see “Info button” on page 65

## Cellular

- IP Address - indicates a connection to the Internet
- Modem Status

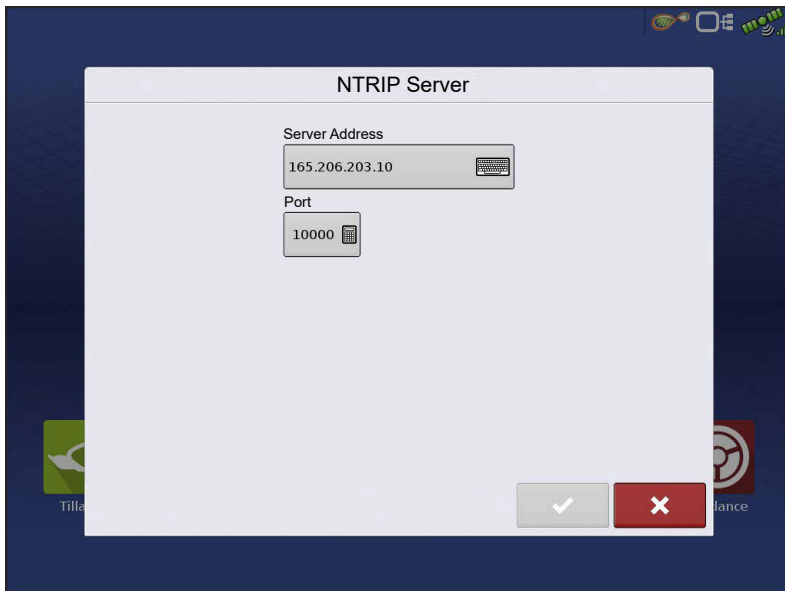

## NTRIP Server

- Server Address
  - Port
- Server Address and Port are provided by the NTRIP Network.

Cellular

IP Address: 10.44.64.32

Modern Status: Connected

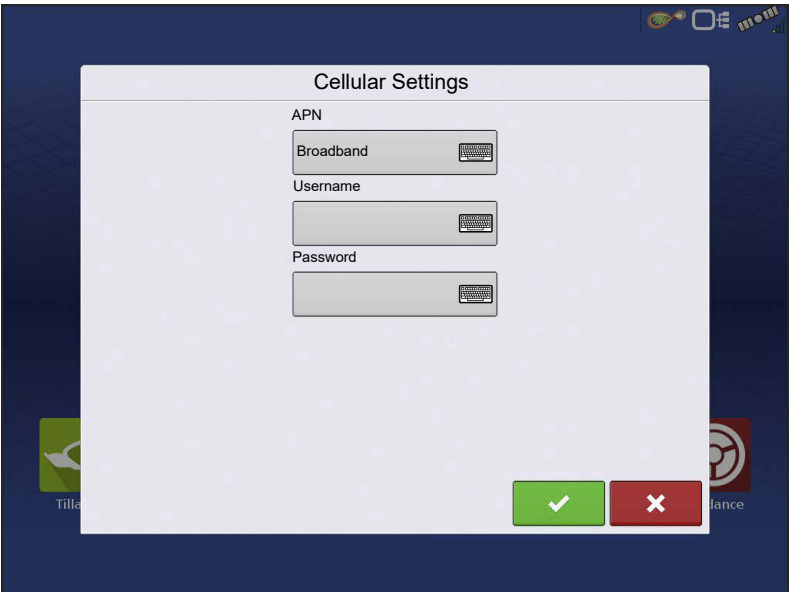
**Cellular Settings**

APN

Broadband

Username

Password

✓ ✗

**Cellular Settings**

- APN
- Username
- Password

APN, Username and Password are Network provided settings. Contact the Cellular provider for this information.

Info

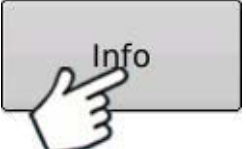

**Stream Info**

Stream: RTCM3\_MAX

Format: RTCM 3

Format Details:

Navigation System: GPS & GLONASS

Network: Iowa RTK Network

Authentication: Required

**Info button**

- Stream
- Format
- Format Details
- Navigation System
- Network
- Authentication

The information shown on this screen is provided by the NTRIP Network.

## RTK Settings - 400 MHz

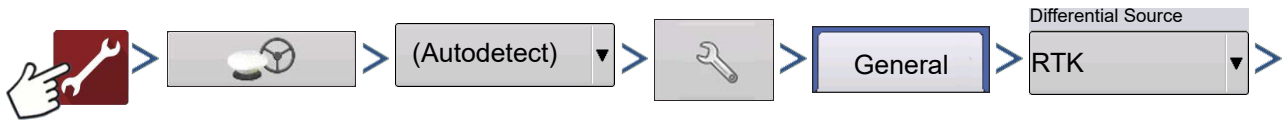

**Channel Spacing**—Use drop-down menu to select Channel Spacing  
**Frequency**

 Press button to add a Frequency

Select frequency and press button to delete selected frequency.  

Select frequency and press button to make selected frequency active  

## RTK Settings - 900 MHz

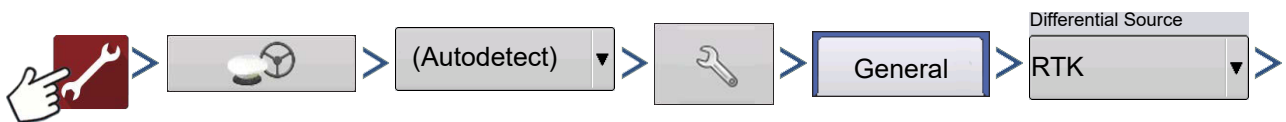

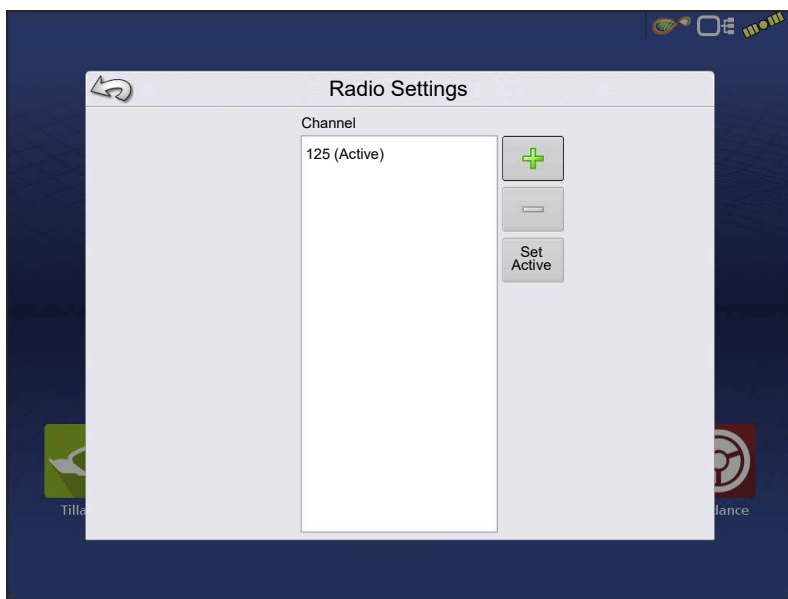

## Frequency



Press button to add a Channel



Select channel and press button to delete selected channel



Select channel and press button to make selected channel active

## Upgrade Receiver

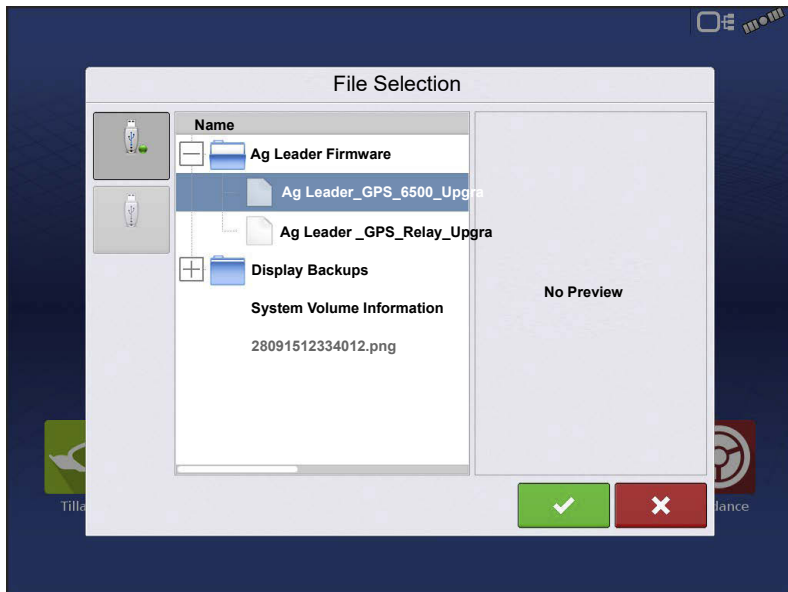
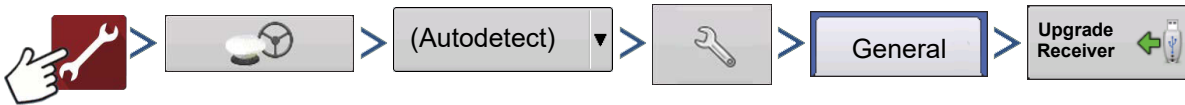

Select file downloaded from Ag Leader website

Select .fw3 file from USB drive.

Press  to accept.

Display will upgrade receiver.

Press  to return to previous screen without updating receiver.

## Serial Port Settings

### Port A tab

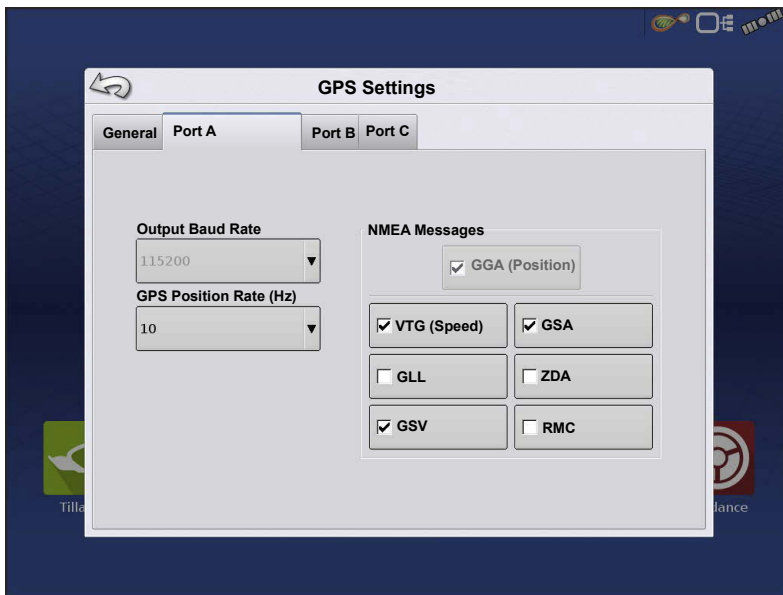
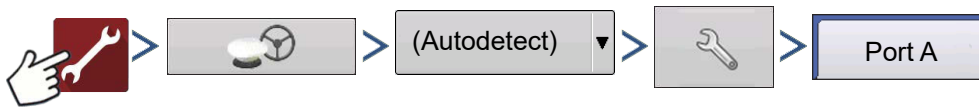

The Serial Port Settings screen is the place where GPS output can be adjusted. The appearance of the Serial Port Settings screen varies depending upon GPS receiver model.

**Output Baud Rate**—Displays the speed at which the receiver communicates with the display. For optimal performance, the GPS baud rate is set at 115200. Output baud rate set automatically with GPS 6000/6500

receivers.

**GPS Position Rate (Hz)**—Represents the cycles per second (shown in Hz) that the display receives position information from viewable satellites (10 Hz recommended).

**NMEA Messages**—These checkboxes represent various communication protocols or formats that have been set by the National Marine Electronics Association (NMEA), and used in information “strings” or sentences output by the GPS Receiver. At present, the display only requires two NMEA Message formats: GGA and VTG.

- GGA: position in longitude and latitude.
- VTG: ground speed.
- GSV, GSA: required to view the Satellite Plot, but are not required for GPS information.
- GLL, ZDA, RMC, MSS: Leave these other NMEA message formats unchecked, unless connected to a third-party monitor and have been directed to do so.

## Port B tab

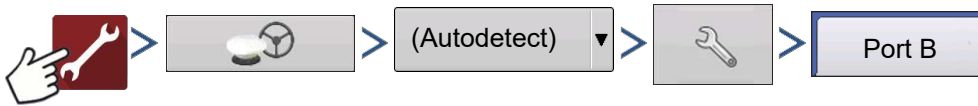

The appearance of the Port B tab is similar to Ports A.

- GGA(Legacy)** —Shortens the decimal precision of the GGA message for connection to legacy equipment.
- GGA(Position)** —Gives increased precision to the GGA message. Most new displays require this turned on.

## Port C tab

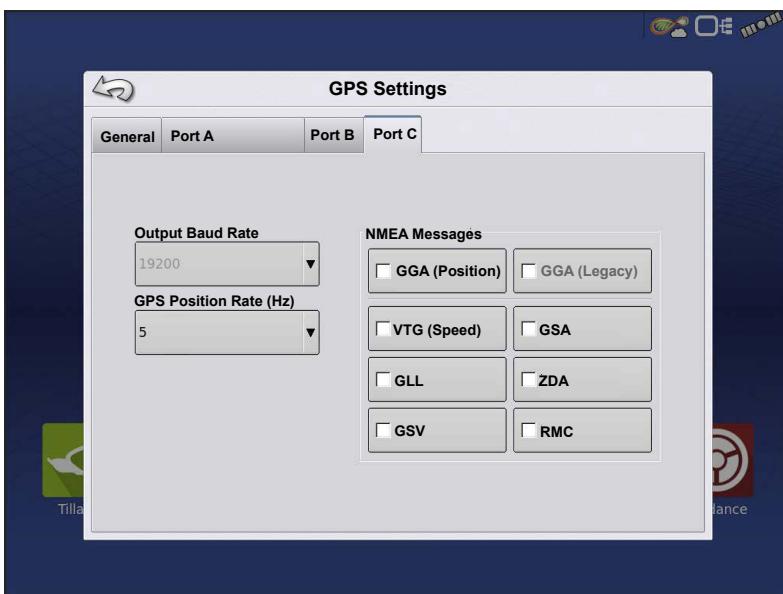
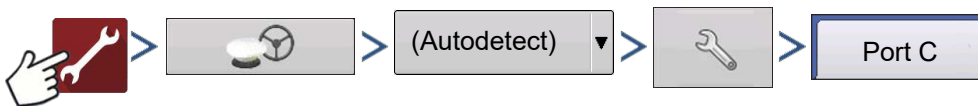

The appearance of the Port C tab is similar to Ports A and B.

- GGA(Legacy)** —Shortens the decimal precision of the GGA message for connection to legacy equipment.
- GGA(Position)** —Gives increased precision to the GGA message. Most new displays require this turned on.



## GPS Information

To access diagnostic information about the GPS signal, press the GPS (Status Indicator) button that appears in the in the upper right hand side of the Status Bar. GPS Information then appears on General, Receiver, and Differential tabs. Information on these GPS Information screens is described on the following pages.

GPS Status Indicator with bars - bars indicate cellular signal strength.

## GPS Information - General Tab

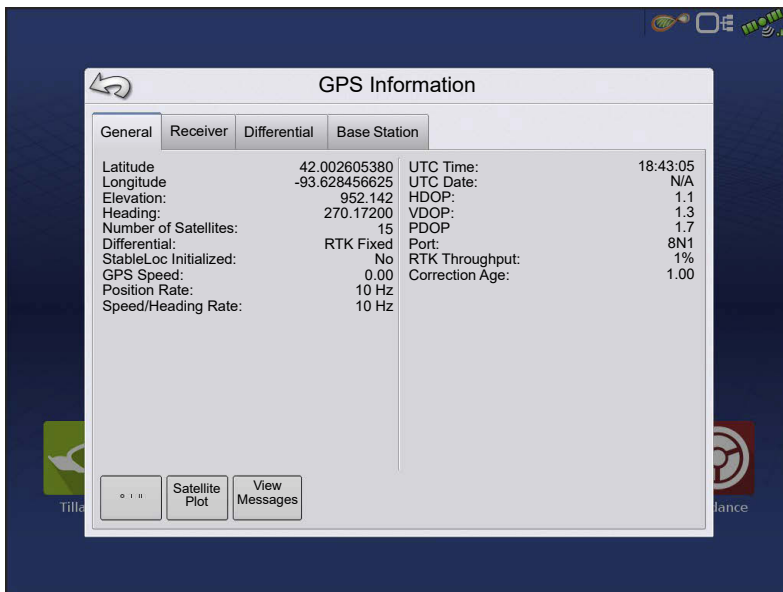

**Latitude, Longitude**—Displays current position (in longitude and latitude).

**Elevation**—Shows elevation of receiver.

**Heading**—Displays degree heading of travel.

**Number of Satellites**—Number of tracked satellites used in position fix.

### Differential

- **No Diff**—Indicates the receiver is not receiving a differential GPS signal.
- **Diff On**—Indicates the receiver is receiving a differential GPS signal.
- **GLIDE**—GPS 6000/GPS 6500 Only.
- **WAAS/EGNOS**
- **TerraStar**—GPS 6500 Only.
- **RTK Fixed**—The receiver is receiving a valid RTK differential source.
- **RTK Float**—The receiver is receiving information from the Base Station, but the signal is not strong enough for an RTK fix.

**GPS Speed**—Real-time speed of travel.

---

**Position Rate**—The frequency that the receiver is sending the display the position in longitude and latitude (GGA). For example, at 10 Hz the display would be receiving a position message 10 times every second.

**Speed/Heading Rate**—The frequency that the receiver is sending the display ground speed and heading (VTG)



**NOTE!** Position Rate and Speed/Heading Rate should both be set at a minimum of 5 Hz for guidance or steering.



**Change Longitude/Latitude Format**—Pressing this button changes the Longitude/Latitude format. These can either be shown in Degrees, Minutes and Seconds; or Decimal Degrees.

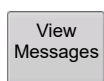

**View Messages button**—see [GPS Messages on page 151](#).

**UTC Time**—UTC is an acronym for Coordinated Universal Time, a high-precision atomic time standard that defines local time throughout the world. If receiving information from satellites, the UTC Time should automatically update.

**UTC Date**—If receiving information from satellites, the UTC date should automatically update.

**HDOP**—Horizontal Dilution of Precision (HDOP) indicates the quality of the horizontal GPS position. Lower HDOP numbers are optimal, higher numbers are undesirable.

**PDOP**—Position Dilution of Precision (PDOP) is a unitless measure indicating when the satellite geometry can provide the most accurate results. When satellites are spread around the sky, the PDOP value is low and the computed position is more accurate. When satellites are grouped close together, the PDOP is high and the positions are less accurate. Lower PDOP numbers are optimal, higher numbers are undesirable.

**Port**—The connection between the display and the GPS as established at a message format and baud rate.

**RTK Throughput**—Indicates a percentage of information available from the RTK base station. Used for troubleshooting an RTK link between the base and rover.

**Frequency**—The Correction Frequency indicates the GPS satellite frequency used by the receiver.

 **NOTE!:** The Correction Frequency diagnostic does not show for WAAS connections.

**Correction Age**—The length of time since the GPS receiver has obtained its last update.

 **NOTE!:** The age of the DGPS corrections (as delivered to the GPS receiver) will vary from one second to several seconds, depending on the characteristics of the individual satellite signals.

## GPS Messages

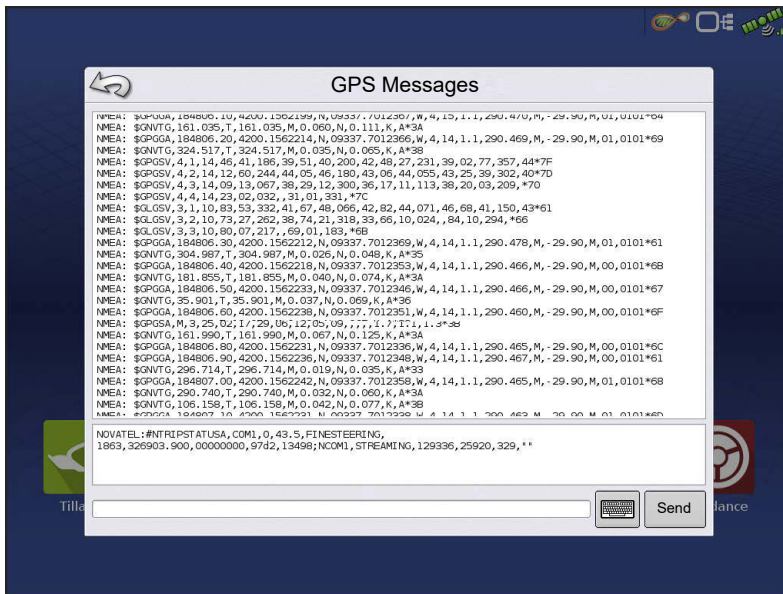

View the NMEA messages coming from the receiver.

Press  and use keyboard screen to write a command to the receiver. Only send commands to the receiver when directed to by technical support.

Press  to send message to the receiver.

## Satellite Plot





The Satellite Plot feature can display both a plot or a graph. The information on these screens is used as an advanced diagnostic tool for GPS satellite availability. In the event of GPS availability issues, technical support may request to view these screens.

### Satellite Plot - Graph

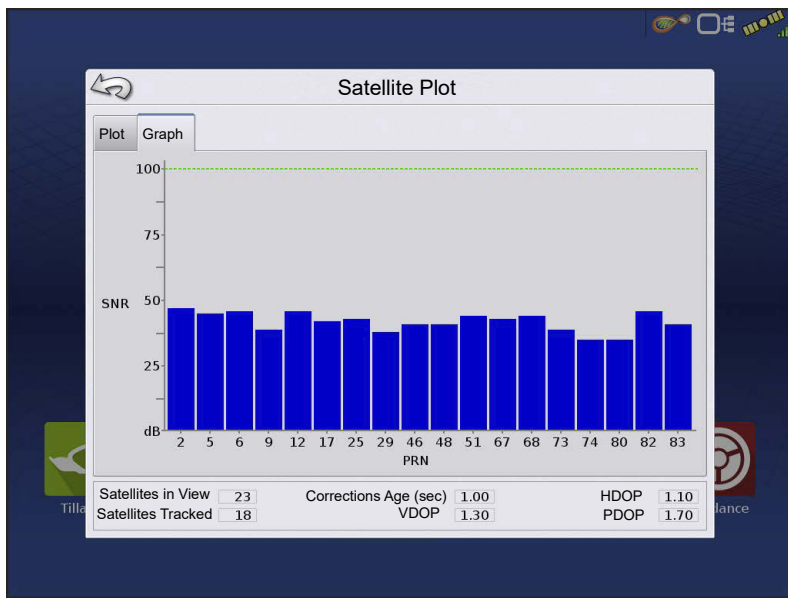

Satellite Plot requires GSV and GSA NMEA messages to be turned on from the GPS receiver.

Graphically shows satellite PRN's and SNR.

## GPS Information - Receiver Tab

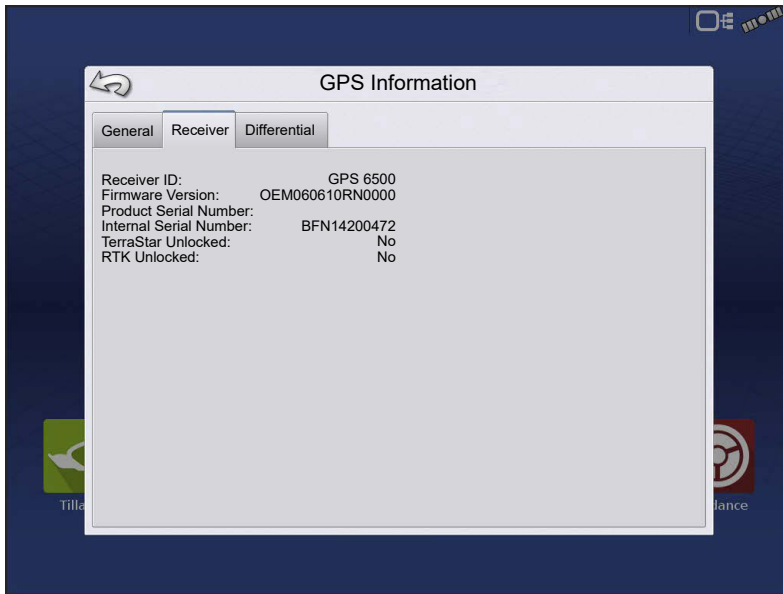

- Receiver ID
- Firmware Version
- Product Serial Number (enclosure)
- Internal Serial Number
- TerraStar Unlocked

- RTK Unlocked

## GPS Information - Differential Tab

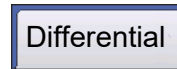

**Active Estimated Error**—Estimated error of the active differential source.

**Active Differential**—Indicates the active differential source and will vary depending on the current state of StableLoc.

**Selected Differential**—Indicates the selected differential source (the source selected in the GPS setup).

**StableLoc Error Limit**—Indicates the error limit selected in the GPS setup.

**Device Name**—Indicates the connected Relay Module.

**Software Version**—Software version of the radio/modem within the Relay Module.

---

**Manufacturer**—Manufacturer of the Relay Module.

**Serial Number**—Serial number of the Relay Module.

**Signal Strength**—Shows cellular signal strength.

**Mobile Directory Number**—Relay CDMA/GSM Only, used for troubleshooting

**Mobile Subscriber ID**—Relay CDMA/GSM Only, used for troubleshooting



**NTRIP Connect/Disconnect**—Connect or Disconnect from NTRIP Source.

**RTK Convergence**—Three states to indicate the current convergence level.

**TerraStar Convergence Limit**—Maximum allowable error for TerraStar accuracy. When estimated error is larger than convergence limit, system will not allow Autoswath and steering.

**Subscription Valid**—Notes if receiver as a currently active TerraStar Subscription

**Valid Unit**—End date for current subscription

**Subscription Type**—Shows active subscription type. "Term" subscriptions are a subscription type with an end date.

**Position Status**—Shows current state of TerraStar signal.



**Red Arrows, pointing out**—The device is not currently converging on RTK. This may indicate a RTK link problem.



**Green Arrows, pointing in**—The device is currently converging, but not ready for RTK fix.



**Green Bull's-eye**—The device is converged on RTK.

## Base Station

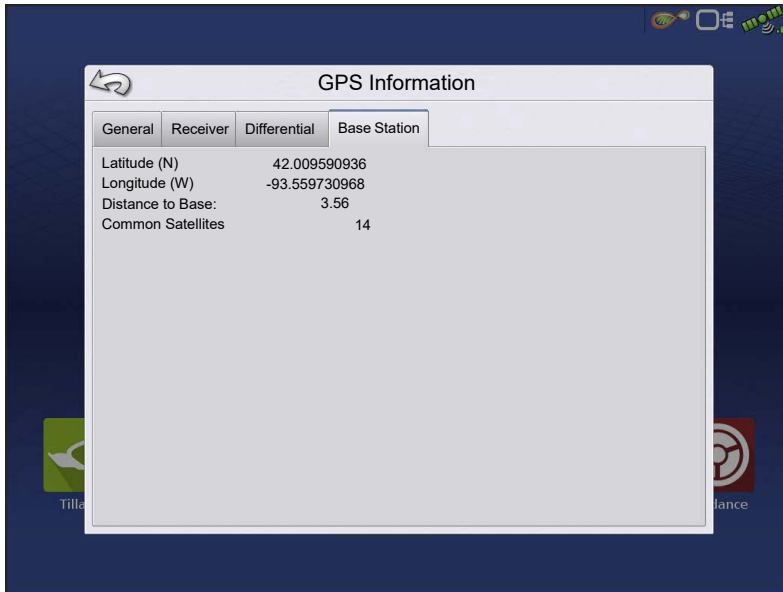

Displays base station specific information

**Latitude**—Latitude of Base Position.

**Longitude**—Longitude of Base Position.

**Distance to Base**—Distance to Base Station.

**Common Satellites**—Shows the number of Satellites the receiver has in common with the base station.

## RTK/NTRIP Information (ParaDyme/GeoSteer Only)

The following information appears on the second GPS Information screen for RTK or NTRIP.

**Convergence (%)**—Successful communication between Base Station and ParaDyme Roof Module.

**Radio Throughput**—Displays percentage of data received from Base Station.

**Distance to Base**—Shows distance to Base Station in miles (kilometers).

**Base Channel**—Displays Channel ID of Base Station.

**NTRIP**—(NTRIP users only) Shows either Connected or Disconnected.

## GPS Information - NTRIP





**NTRIP Connect**—Connects the display to the NTRIP correction source.

**NTRIP Stream**—Network mount point.

**NTRIP Status**—Displays NTRIP connection; either Connected or Disconnected.

**Cellular Status**—Displays status of ParaDyme cellular modem; either

Connected or Disconnected.

**Cellular Signal Strength (%)**—Displays a number between 0 and 100%.

**WiFi Status**—Displays status of WiFi router; either Connected or Disconnected.

**WiFi Signal Strength**—Displays a number between 0 and 100%.



## Guidance Tab on Mapping screen

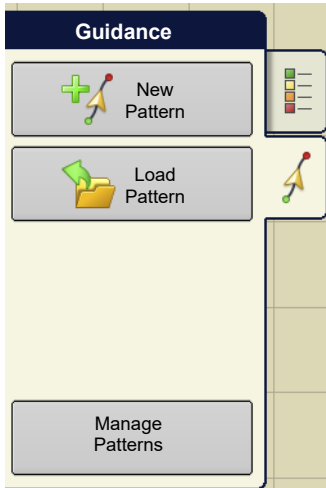

Use the Guidance tab on the Mapping screen to create a new pattern, load an existing pattern, or adjust Guidance Options and Guidance Settings. This tab changes its appearance after pattern is created or loaded.

Before creating any patterns, the map screen's Guidance tab appears as shown.





**NOTE!** Guidance pattern will default to the one last used.

Guidance patterns can be set to widths up to 2000 ft.

## New Pattern—Straight

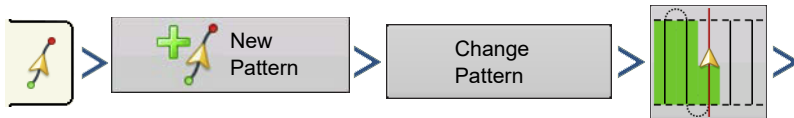
### Select Pattern



Press . Display returns to the Mapping screen.

System defaults pattern type to last used. Press the pattern icon to select a different pattern.

- Implement Width (from Implement Setup)

- Guidance Width input box

- Enable Tramlines checkbox. See

[Tramlines on page 179.](#)

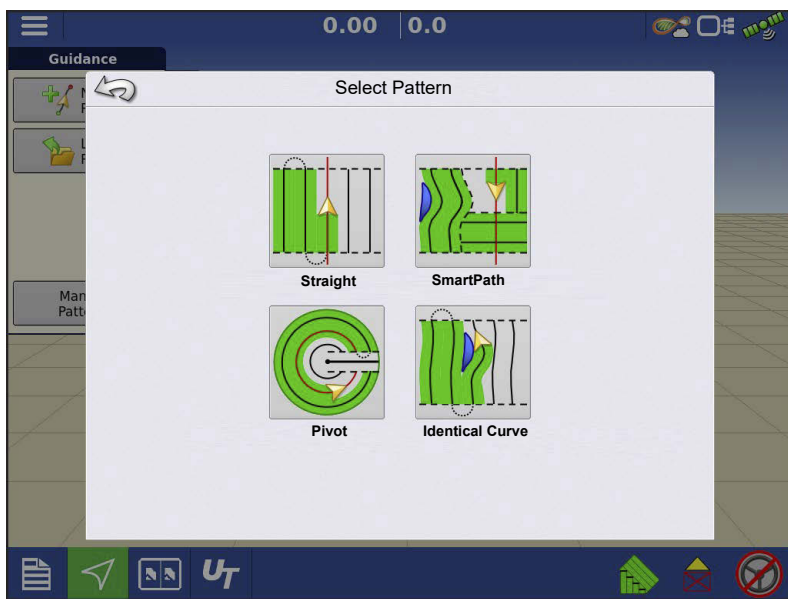

•Change Pattern

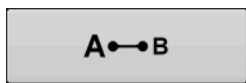

## Create AB line using 2 points

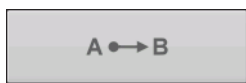

Press to mark A point. A green ball appears on the map screen where point was placed.

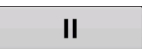

Button is greyed out until a minimum of 100 ft is driven.

- Pause - Press  to pause path during path creation
- Resume - Press  to resume path during path creation
- Cancel - Press  to cancel path during path creation

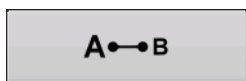

Press to mark B point. The AB line appears on the map screen and point B is marked with a red ball.

## Create AB line using Current Location and Heading

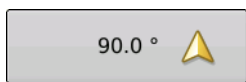

uses current location and heading, line extends 1 mile before and after the A point (recommend vehicle having forward motion to get a good heading).

## Create AB line using Current Location and Inputting Heading

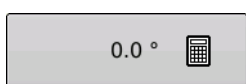

uses current location and input heading, line extends 1 mile before and after the A point.

Patterns are automatically saved when the guidance pattern is created.



**NOTE!:** On straight AB lines, if current swath is longer than the previous one, the display automatically extends the guidance path for the following swaths.

## New Pattern—Identical Curve

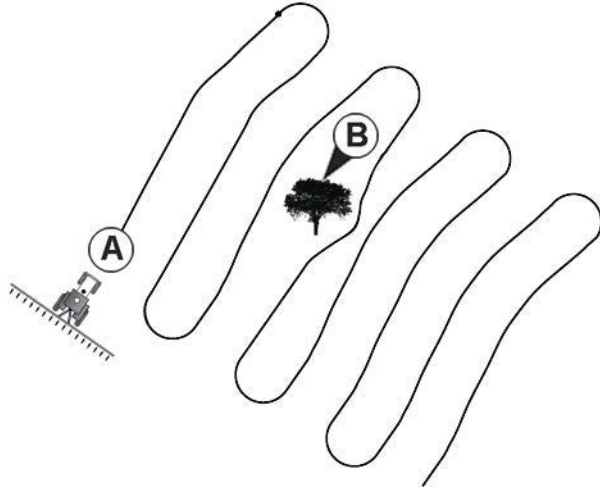

Use the Identical Curve pattern to follow gentle contours in the field. This pattern provides guidance based on the original curve driven.

## Select Pattern

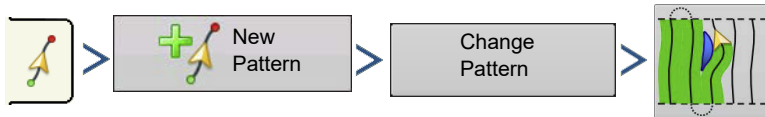

System defaults pattern type to last used. Press the pattern icon to select a different pattern.

Press . Display returns to the Mapping screen.

## New Pattern—Pivot

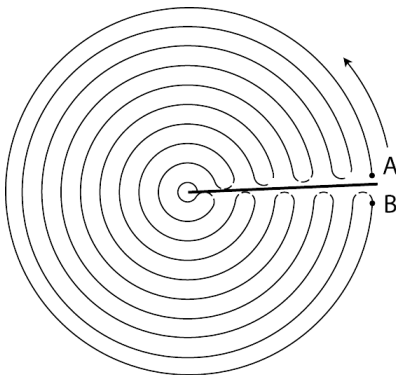

Use the Center-pivot pattern for a field that is irrigated using a center-pivot. With this pattern, drive concentric circles around the center-pivot. The display will calculate the center point based on path driven. Otherwise, enter latitude and longitude of the center point, if known.

## Select Pattern

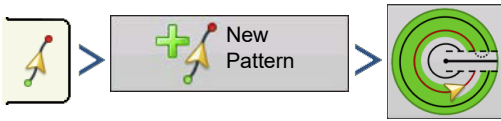

System defaults pattern type to last used. Press the pattern icon to select a different pattern.

- Implement Width (from Implement Setup)
- Guidance Width input box
- Manual Entry checkbox and Latitude and Longitude input boxes

Press . Display returns to the Mapping screen.

## Pivot Shift

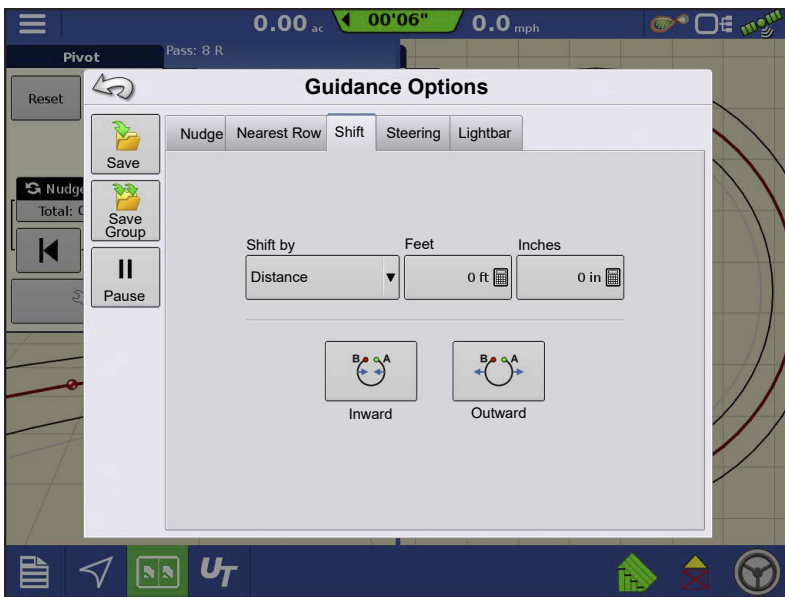

**Shift by Distance**—Shift the pivot pattern, inward or outward, by a desired distance.

**Shift by Row**—Shift the pivot pattern, inward or outward, by a desired number of rows.



**Nearest Row**—Shift pivot pattern to the nearest row based on current location. User must enter row spacing.

## Create AB line using driven path

- Position one wheel of the vehicle in a pivot wheel rut, with the rear of the vehicle to the pivot arm.

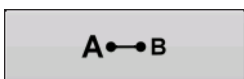



Press to mark A point. A green ball appears on the map screen where point was placed.

- Drive desired path around the field. Keep the vehicle wheel in the rut.



Button is greyed out until a minimum of 160 ft has been driven.

- Pause - Press  to pause path during path creation
- Resume - Press  to resume path during path creation
- Cancel - Press  to cancel path during path creation

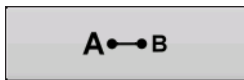

When almost back to the pivot arm or the edge of the field, press to mark B point, the AB line appears on the Mapping screen and B point is marked with a red ball.



1. Set the Field Edge. Do this when the Pivot Field Edge window appears on display.

From here, choose one of three options:



**Shift By Distance**—This sets the field edge as the distance and direction in relation to the AB Line created. In the Pivot Field Edge Distance portion of the window, enter the distance in feet and inches.

multiplied by the number of spacing. In the Pivot Field Edge Distance portion of the window, enter the Number of Rows and Row Spacing.

### Cancel

The vehicle uses the driven pass as the AB Line.

**Shift By Rows**—This sets the field edge as the number of crop rows

2. If Shift by Rows was chosen in the previous step, use  to enter the Number of Rows and Row Spacing. Choose the direction relative to the AB Line (either Outward or Inward), and press  to continue.

3. Steer the vehicle so that green lights are centered in the lightbar as path is driven.



**NOTE!:** To work from the center of the field outwards, the initial pivot must have:

- A radius of at least two swath widths.
- An arc length of at least two swath widths.

## New Pattern—SmartPath®

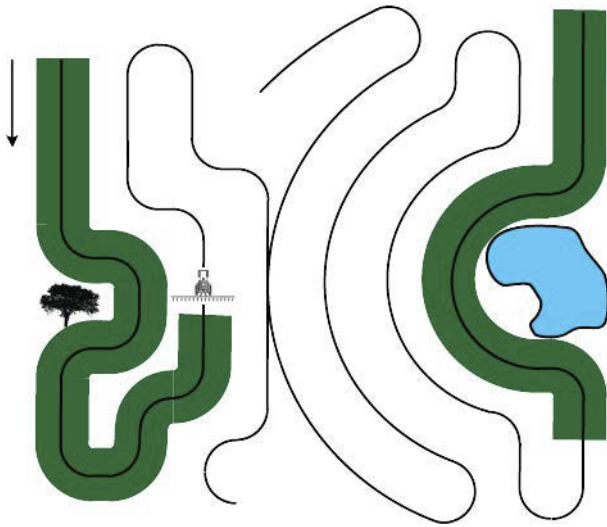

The SmartPath™ pattern is designed to give guidance from any previously-driven pass. This is used in irregular-shaped and terraced fields where all passes cannot run parallel to each other.

SmartPath allows moving to a different area of the field, and resuming a previous guidance pattern later.

SmartPath can be used to create straight AB patterns and curved patterns within the SmartPath

pattern. Cycle between Straight AB and SmartPath at any time within SmartPath guidance pattern.

### Select SmartPath

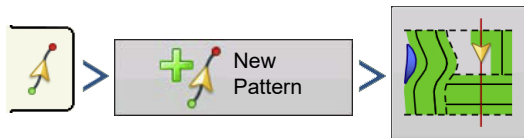

System defaults pattern type to last used. Press the pattern icon to select a different pattern.

Press . Automatically return to the Mapping screen.

### Inputting Paths into SmartPath

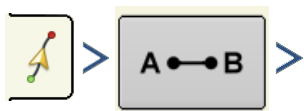

#### AB Manager

The AB Manager screen allow user to create, edit, remove, and load paths into SmartPath.

Create up to 10 different AB lines within SmartPath.

-  Press the Back button to close the screen.

## Cycle between Loaded Paths



Press forward or back to cycle through the paths loaded into SmartPath.

Driving onto the Projected Path, system guidance uses this as the Followed Path.



Once the AB line is created, switch between the AB line and SmartPath patterns by pressing the AB/SmartPath toggle.

The Mapping screen changes its appearance to Perspective View, and SmartPath settings are shown in the Mapping toolbox. Drive along path to create.



**NOTE!:** The display will not create A point with SmartPath, unless mapping a Straight AB line within it.

After turning around on first pass, the system guidance will follow a maroon-colored line parallel to previously-driven pass.

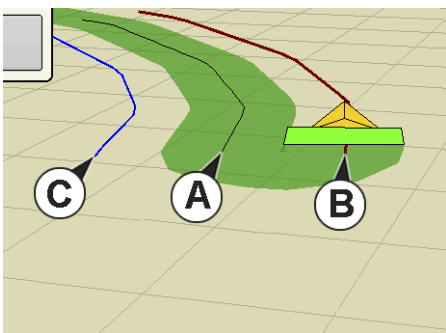

Continue using SmartPath, the map screen will display three lines:

- (A) The Base Path

Appears as a black line, is the initial SmartPath created on the first pass.

- (B) The Followed Path

Appears as a maroon-colored line, is the path that vehicle is currently using.

- (C) The Projected Path

Appears as a blue-colored line on the opposite side of the Base Path and is an alternate path parallel to the Base Path. The system guidance created this path while the base path was created.

This is the path that vehicle would have taken if turned in the opposite direction.

**NOTE!:**

- The Projected Path and Base Path both remain in display memory, until the Reset button is pressed without saving the SmartPath pattern.
- Pressing the Save button saves all the SmartPath passes within the display's memory for future use.

## Select a Previous SmartPath Pass

If SmartPath is specified as desired pattern, but an active guidance pattern is not being followed, the Guidance System automatically begins searching for SmartPath patterns to use.



To use a previously-create SmartPath pattern, press either forward or back to select next or previous pattern.

**NOTE!:**

- When the guidance system looks for other available SmartPath patterns, it first displays the nearest-available pass.
- Adjust the available area in which the Guidance System searches for previously-created SmartPath passes. To do this, adjust the Heading Threshold settings on the Smart tab of the Guidance Options screen.

## SmartPath Guidance Options



SmartPath only creates a SmartPath pass when data is logging in the field. However, this option can be switched to create SmartPath passes continually during all field operations.





To adjust this setting, press the Guidance Options button on the Guidance tab. The Guidance Options screen appears. Press the Smart tab Wrench.

- The default setting is Logged Area. This setting only creates passes while logging field data.
- Selecting All Area Covered to create SmartPath passes even when not logging field data.

- The Heading Threshold setting is the available area that the Guidance System uses to search for previously-created SmartPath passes. The default setting is 20 degrees.

## Path Smoothing

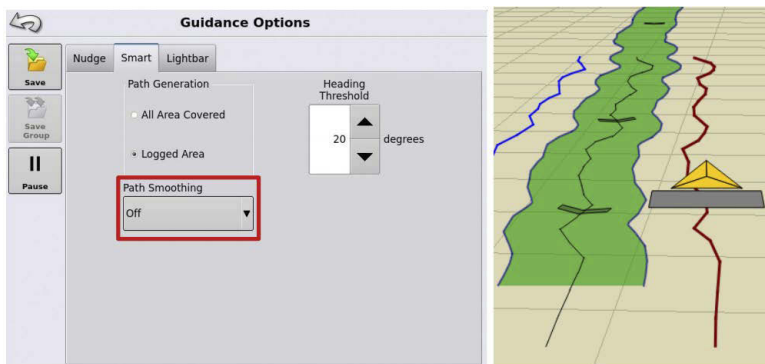

Path Smoothing can be used on SmartPath and FollowPath patterns to smooth out jaggedness when the line is generated. There are 4 options in the drop down. These cannot be changed while steering is engaged.

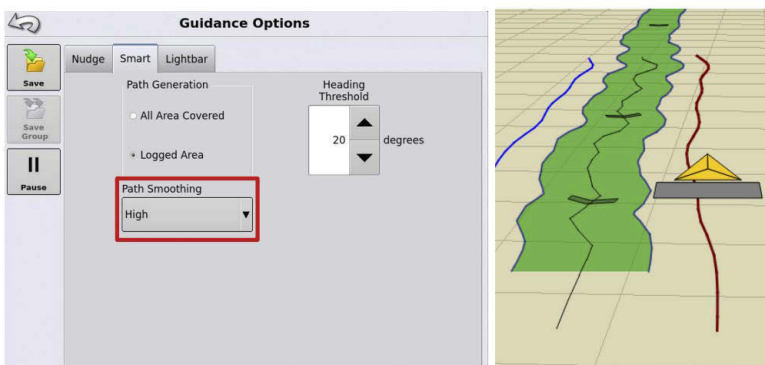

- Off
- Low - Setting will smooth the guidance line to reduce little variations in heading changes.
- Medium - Setting will smooth the guidance line to reduce any moderate variations in heading changes.

- High - Setting will smooth the guidance line to reduce any larger variations in heading changes.

## Boundary Guidance

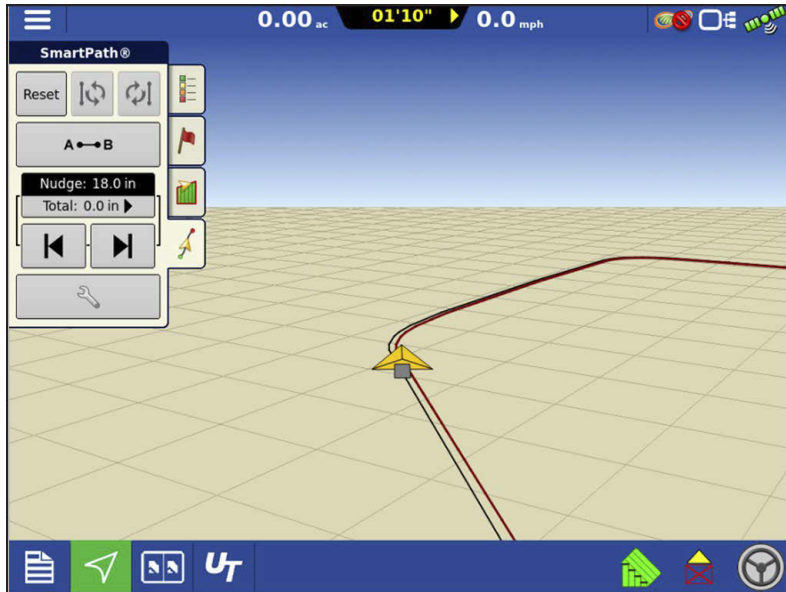

Automatically generates a guidance line based on a set boundary for a field. Once a boundary is set for a field, create a new SmartPath guidance pattern and the guidance line will automatically be generated around the boundary.



**NOTE!:** The Boundary Guidance feature will only generate one pass around the boundary. After the first

pass, a typical SmartPath pattern will be used.

## Boundary Guidance Options

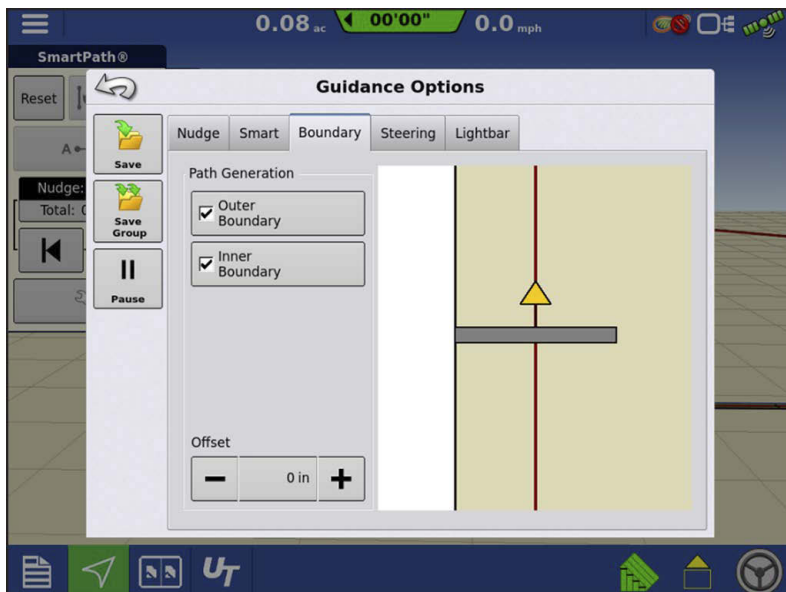

Outer boundary – select this to enable boundary guidance generation on an outer field boundary.

Inner boundary – select this to enable boundary guidance generation on an inner field boundary.

Offset – Offset of the line that is generated. Has a range of +/- 120 inches.

## CartACE™

CartACE™ allows path coordination and information sharing between vehicles. Components of CartACE include FollowPath guidance and the Live Grain Tank Counter.

To utilize CartACE you will need:

- InCommand display
  - 1200 and 800
- DisplayCast unlock on all displays
- AgFiniti Essentials
- Matching DGPS sources

For example all receivers need to use WAAS or all need to use RTK on same base.

## CartACE - FollowPath™

Provides automatically created guidance path based on shared combine coverage. Guidance line is automatically created based on combine swath and requires no input from grain cart operator.

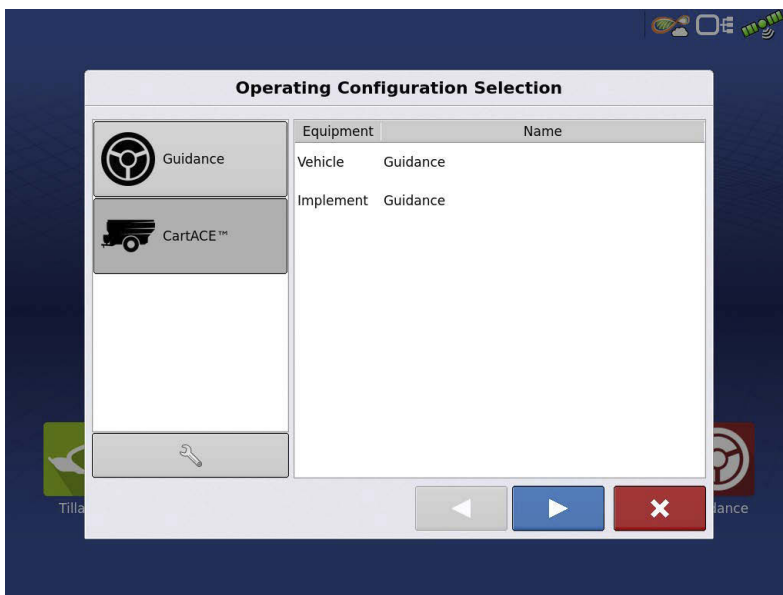

1. Select Guidance on home screen

Select CartACE option

2. Load Grower/Farm/Field

3. After loading to run screen, user will be prompted to select applicable harvest event used to create Follow Path.

a. It is very important to select the correct event as this is what FollowPath will use to create guidance lines. Selecting the incorrect event could lead to improper guidance and

the potential for collision.

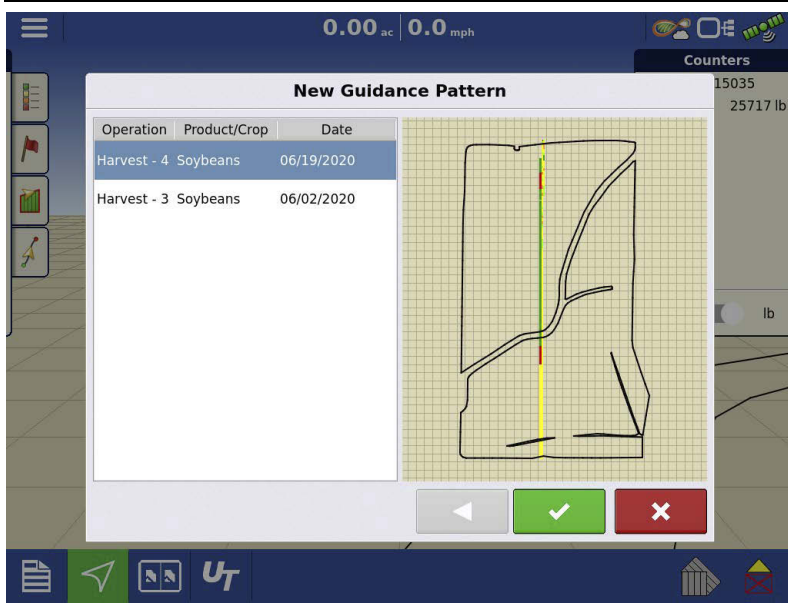

b. If other events need to be selected, hit New Pattern.

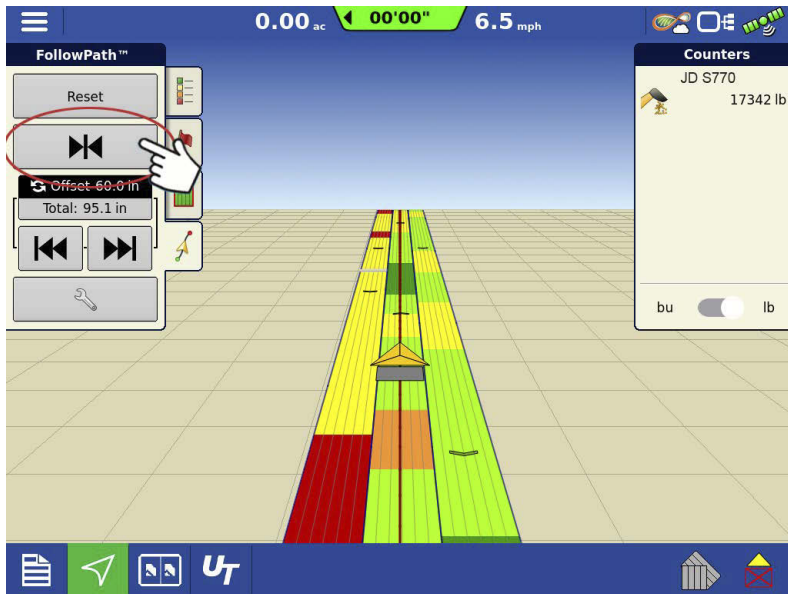

4. Drive under auger

Hit re-center button 

to set correct offset

a. Repeat for other combines as needed

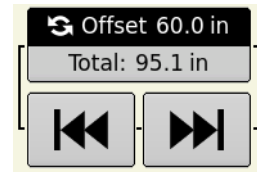

b. The offset number shown on screen is the distance from the right side of the current pass

• Only needs to be set once per combine configuration. Information is stored and will be used going forward.

- If multiple combines are in use, to switch from offsets, simply drive close to the desired combine and the stored offset will be used automatically.

At this point you can now engage on the generated line. As you move through the field, new guidance lines will be generated automatically based on the combine pass the grain cart is on.

## Re-center/Nudge



If small adjustments need to be made, use the nudge left/right, you can toggle between a large and small offset by tapping the circular arrows button.

If offset needs to be adjusted, navigate to the desired position and hit re-center button.

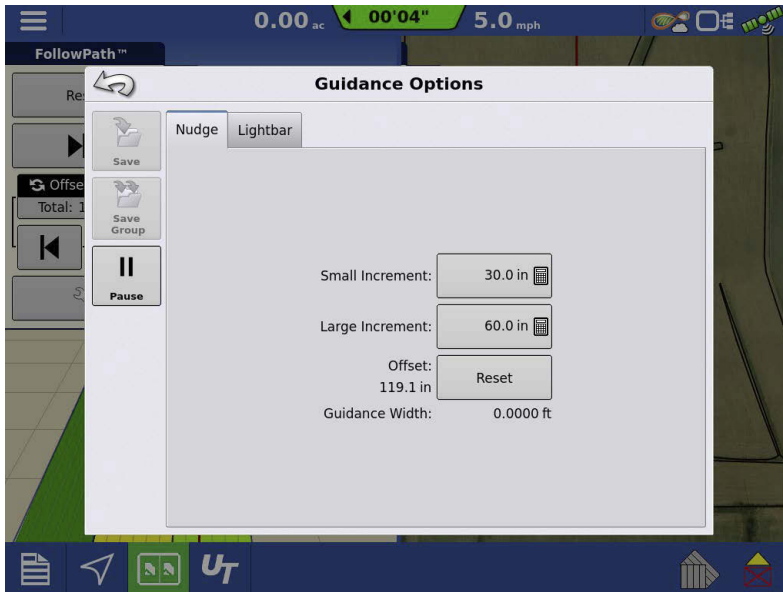

Small and large nudge increments can be adjusted in the Guidance Options. Can also view or reset offset back to center of line within Guidance Options.

If multiple combines are in the field, the FollowPath will allow you to save unique offsets and it will automatically swap based on proximity to different combines. You will need to move far enough away from the current one to

swap to a different combine.

## Live Grain Tank Reset Sensor

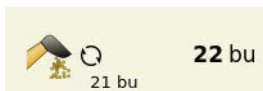

This feature automates the resetting of the Grain Tank Counter and provides on-screen real-time details of bushel counter on all connected devices.



Feature requires kit PN 4006109, containing module and sensor, be installed on combines.

Once installed, the live grain tank counter replaces top resettable counter on combine run screen.

Counter is automatically reset when sensor is uncovered and, when covered, jumps to calibrated value and starts counting up.

A. Uses a calibrated value to estimate number of bushels in bottom of bin before sensor is covered.

B. Calibration occurs on first load of event change or reboot.

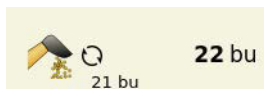

C. Calibration can be reset by tapping on and new value will be generated on next uncover/cover cycle of the sensor.

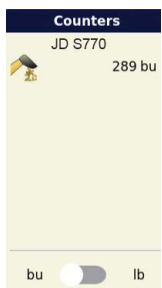

Value is sent out via DisplayCast to connected grain cart configurations as well as AgFiniti Mobile.

If more than one combine is connected, each will show in the list.

Process is all automated, no user input is required.

Counters, in both combine and grain cart, can be changed from bu to lbs if needed (only option when standard units are in use).

## AutoSave

Guidance patterns can be automatically saved after completion.

- Feature is on by default.
- A toast will notify user that pattern was saved with default name of date and time.
- Patterns can be renamed or deleted.
- Features can be disabled from following location:



## Loading a Guidance Pattern

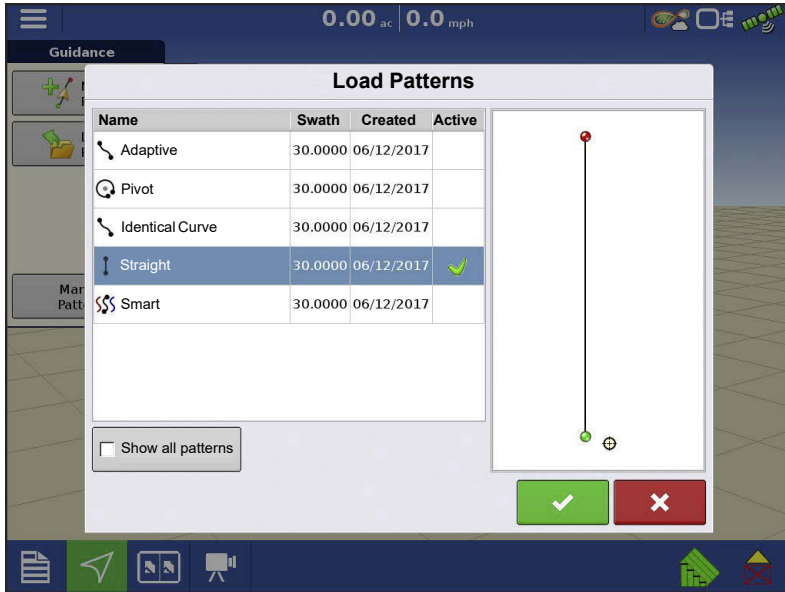

List of guidance patterns for the active field will populate after selecting load pattern.

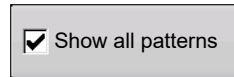

Check the box to show all patterns in the display.

Highlight pattern and press  to

load pattern to Mapping screen.

For Loading a Guidance Pattern while using DisplayCast®.

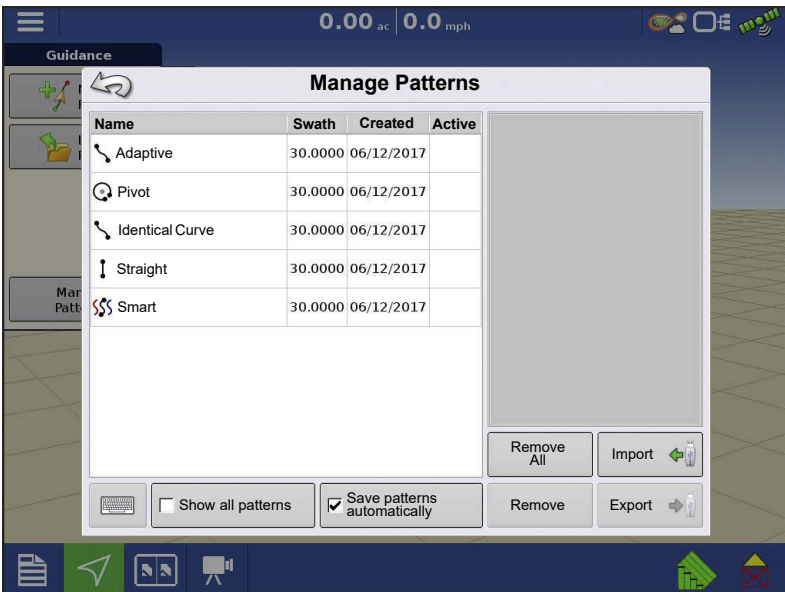

## Manage Patterns

### Spatial Sort

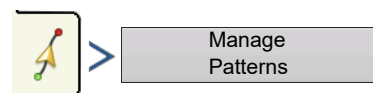

Spatial Sort allows the user to select any guidance pattern in the display, sorted by distance from the GPS location.

Pattern at the top of the list will be the closest to current GPS location.

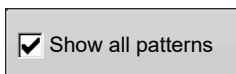

Check the box to show all patterns.

---

## Import Pattern



Display indicates when file has been successfully copied.

## Export Pattern

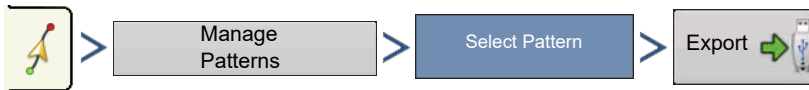

Display indicates when file has been successfully copied.

## Edit Pattern

To rename a pattern, press Manage Patterns button on Guidance tab of Mapping toolbox. Press  to enter a pattern name. New pattern name appears in pattern list of Manage Patterns screen.

## Remove Pattern/Remove All Patterns

To remove a pattern from the display memory, first press the Manage Patterns button on the Guidance tab of the Mapping toolbox. At the Manage Patterns screen, press either:

- Remove button to delete one pattern file; or
- Remove All button to delete all of them for the current field.

## Reset Pattern

When using an already-saved pattern, to switch over to a different pattern in the same field, use the Reset Pattern feature by following the steps below.

### 1. Press Reset

Press the Reset button on the Guidance screen.

### 2. Confirm Reset

The Guidance screen appears, asking to reset the current guidance pattern. Press  to continue.

### 3. Create new pattern (optional)

The pattern is now reset. Create a new pattern, if desired.



## Pattern Groups

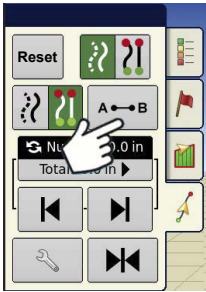

Pattern Groups allow the user to group up to 20 patterns per field, using the Group Manager.

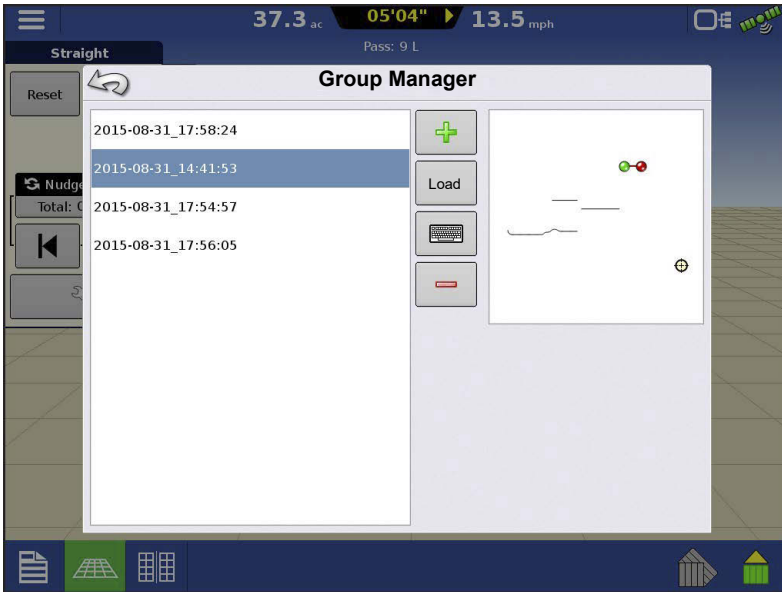

The Group Manager allows the user to add a new pattern or load an existing pattern to a Group. Once a Group is created, it can be saved and reloaded.

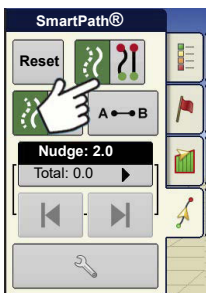

The Pattern Cycle button allows the user to easily cycle between patterns with a single button press. Patterns will cycle in the order they were created or added, starting back at the beginning of the list, once the last patterns is reached.



When loading a Pattern Group, the Group Pattern Setting dialog appears and allows the user to select the Guidance Width and any Shift that needs to be applied to each Pattern within the Pattern Group. User will also have the option to load Curve Patterns as Adaptive or Identical.

Straight AB, Identical Curve, Adaptive Curve and Pivot Patterns can be

grouped. SmartPath cannot be grouped.

## Guidance Options

### Save

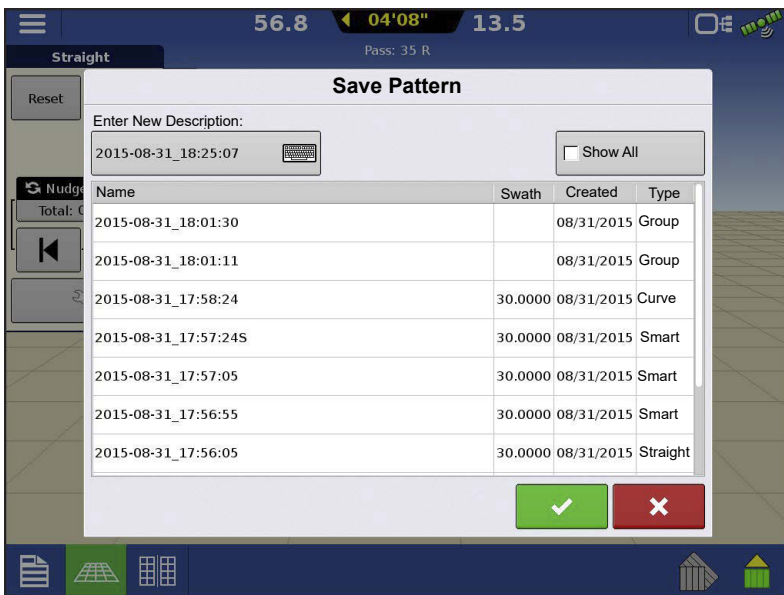

This allows the pattern to be saved to the display's internal memory.

Press  and enter a unique pattern name.

When finished, press .

### Pause

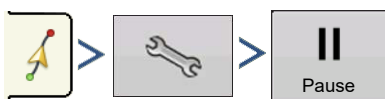

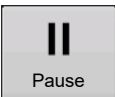

The Pause button allows the display to stop logging points along an AB Line. Once this button is pressed, a Resume button will take place of the pause button until pressed to continue logging.

 **NOTE!:** When using the display to follow a set AB Line and wish to temporarily deviate from this line, use the Pause button to pause the display's guidance logging activity. This feature could be used, for example, by a vehicle operator who must refill a sprayer. When paused, the display will continue to give the distance back to the original pause point position.

- Press  on the Guidance screen. When pressed, the paused location appears on the Mapping screen as a yellow ball.

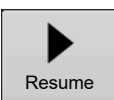
 **NOTE!:** Pause can be used even without a “B point” set. When pressed the lightbar message reads “Need B”. When pause is pressed after setting an AB line, the lightbar will indicate the distance away from the paused location.

- To resume pattern, press  to resume creating the AB Line.

 **NOTE!:** Press the Resume button before returning to the original AB Line, to have display select closest AB Line to vehicle.

## Remark A

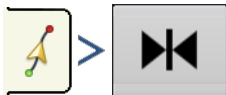

Choose straight pattern, the Remark A button appears on the main Guidance window. The Remark A button "re-marks" the A point by moving it to the current position of the vehicle while maintaining the same heading. A brief message appears in the on-screen lightbar, stating "Point A Remarked."

## Nudge

 **NOTE!:** Only Straight patterns offer two Nudge settings. All other patterns have a single nudge setting.

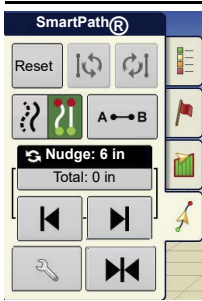

Small Nudge (single arrow) shown.

Nudge allows adjusting the swaths by a specified distance for the direction of travel.

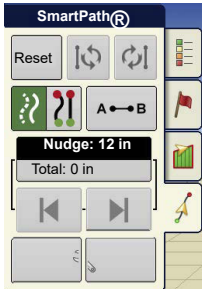

Large Nudge setting (double arrow) - Straight Patterns Only

Use Nudge toggle button  to switch between Small and Large

Nudge setting.

Use Mapping toolbox toggle button  to switch the menu between

Tramline and Nudge on the Mapping toolbox, if Tramlines are enabled.

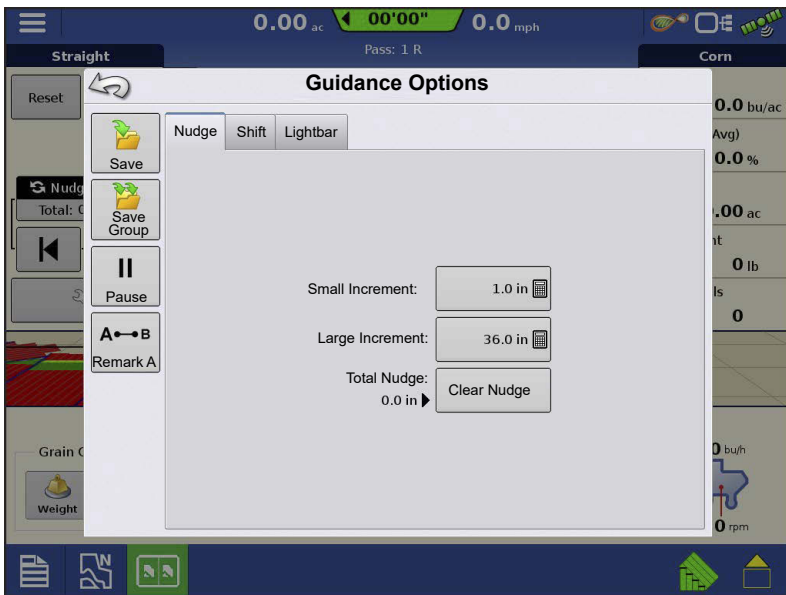

Press  button then the Nudge tab to make adjustments to Nudge settings.

- Press  to enter a distance for increment that the swaths will move with each successive press of the left or right arrows buttons on the Guidance tab.

- To clear out the adjustment and go to the original position, press Clear Nudge.

Screen shows Small and Large increment settings for Straight path. Other Patterns will only show the small increment setting.

## Shift



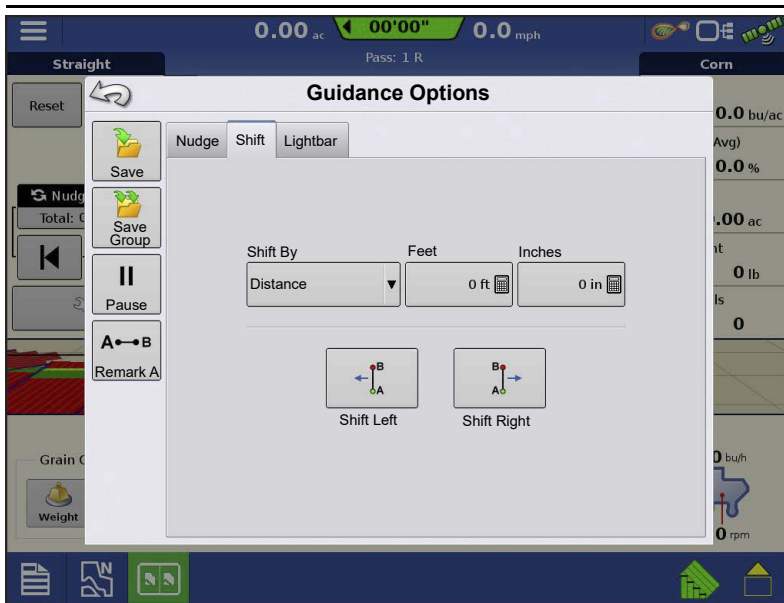



Shift moves all of the swaths by a specified distance to the left or right, (including the AB line). The swaths can be shifted by a distance or number of rows.

- Shift by Distance

Use  to enter the distance that the pattern needs shifted. Use the bottom drop-down menu to enter the direction, (either left or right). Press Apply button to accept change.

- Shift by Rows

Use  to enter the number of rows the pattern needs shifted. Use the second  to select the row spacing. Use the drop-down menu to enter the direction to shift the pattern. Press Apply button to accept the change.



**NOTE!:** The Shift setting is not available with the SmartPath patterns.

## Steering

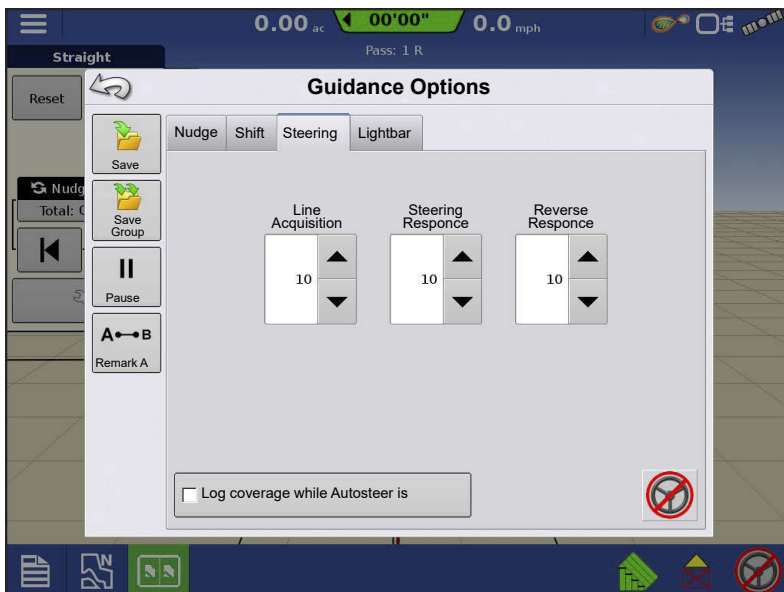

Steering allows users to make autosteer turning adjustments on the go.

- **Line Acquisition**—Determines how aggressively the system steers onto the desired steering path. The ideal setting allows the system to take the shortest route without excessively

sharp or sudden movements of the vehicle.

- **Steering Response**—Controls the oscillations of the vehicle when it is on the desired path.

- **Reverse Response**—Controls the oscillations of the vehicle when it is on the desired path in reverse.
- **Log coverage while AutoSteer is engaged**—checkbox (check for yes, un-check for no). Coverage while engaged is available when an AutoSteering system (SteerCommand, GeoSteer, ParaDyme) is connected. User can still manually control coverage logging with the on-screen coverage button. AutoSwath is unaffected by this selection.

## Lightbar

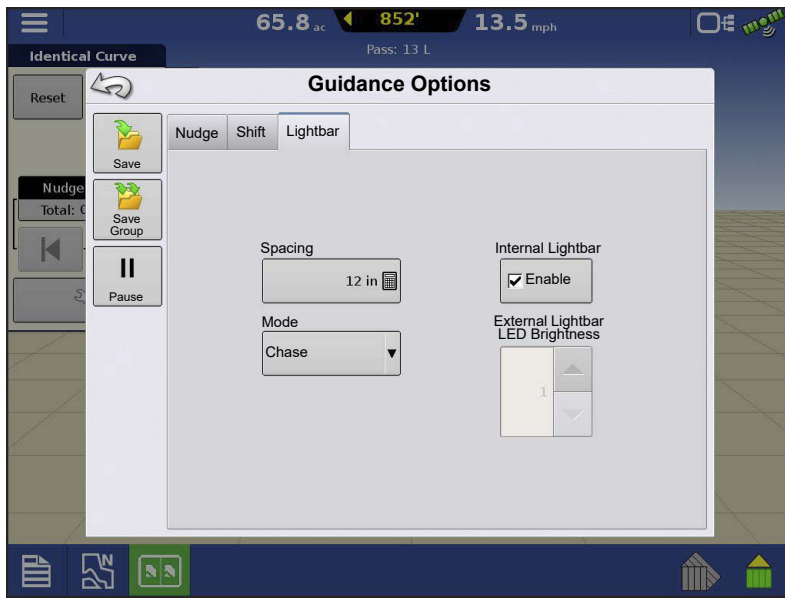



- **LED Spacing**—Enter the distance represented by each square of the lightbar, ½–6 ft (3–182 cm).

- **Mode**

- **Chase**—Center the vehicle by following the indicator lights.

- **Pull**—Center the vehicle by turning in the opposite direction of the indicator lights on the lightbar.

- **External Lightbar LED Brightness**

If applicable, press  /  to enter in a number specifying the brightness of the LED lights on the optional L160 external lightbar. The number 1 is the dimmest and 10 is the brightest. Default is 5.

## Tramlines

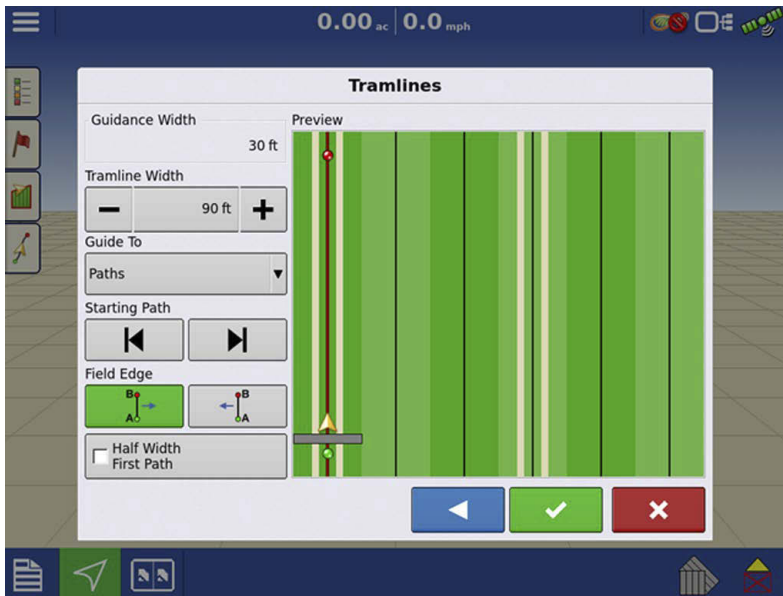

Tramline selection can be enabled from the New Pattern or Load Pattern menu. When enabled the Tramline setup page will appear during the load pattern process. Tramlines can be adjusted anytime from the Guidance Options Menu.

Preview will update as settings are changed for the desired guidance line.

**Guidance Width** – Defined value from the New Guidance Pattern or Load Pattern of first operation (planting)

**Tramline Width** – Desired width of second operation (spraying)

**Guide To** – Select how to guide to the first operation (Paths) or second operation (Tramlines)

**Starting Path** – Arrows allow movement of initial guidance line location in relation to tramline location

**Field Edge** – Direction field will be worked (left or right) from the starting path

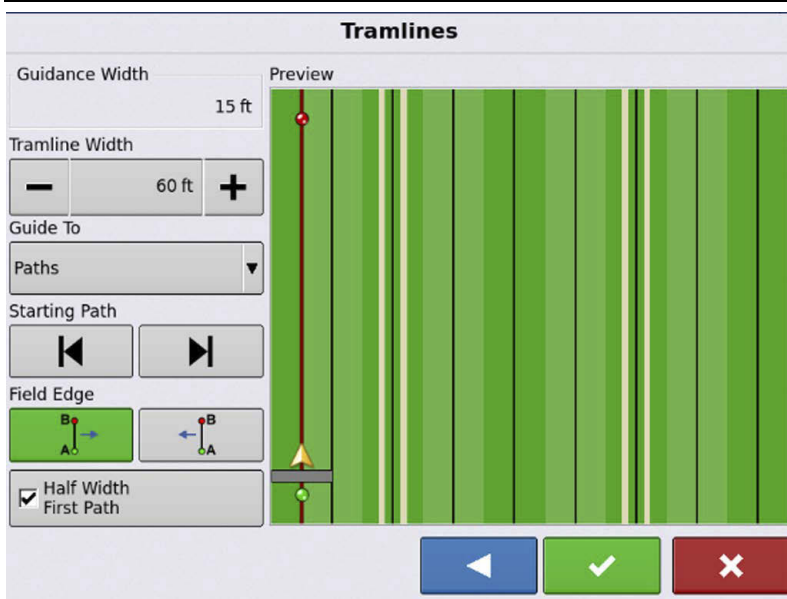

**Half Width First Pass** – Check the box if the first operation (planting) width does not provide the second operation (spraying) tramline in correct location

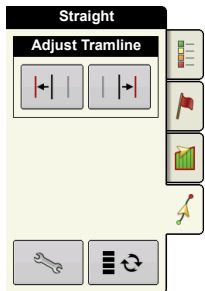

Picture showing half width first pass

### Tramline Adjust



Adjust Tramline - move the placement of the tramline by one pass left  or right .



Use the toggle button to switch menu between Tramline and Nudge on the Mapping toolbox.

An audible warning is sounded to alert the operator a Tramline is reached when the vehicle is  $\frac{1}{2}$  a swath width away.

Tramlines are also numbered under the Pass Number. This number will flash multiple times when the Tramline is reached for a visual warning.

### Access Path

Access Paths allow more precise control of field layout. This is accomplished by allowing the user to bypass a road, ditch, or other obstacle in the field. When used in the case of irrigation ditches or roads that are evenly spaced and a known distance apart users can enter that distance when setting up Access Paths. Guidance lines will skip the Access Path and resume on the other side of it. Below is an example of enabling and using Access Paths.





**NOTE!:** This feature is only available on InCommand version 4.0 and newer.

1. From the Run Screen select New Pattern:

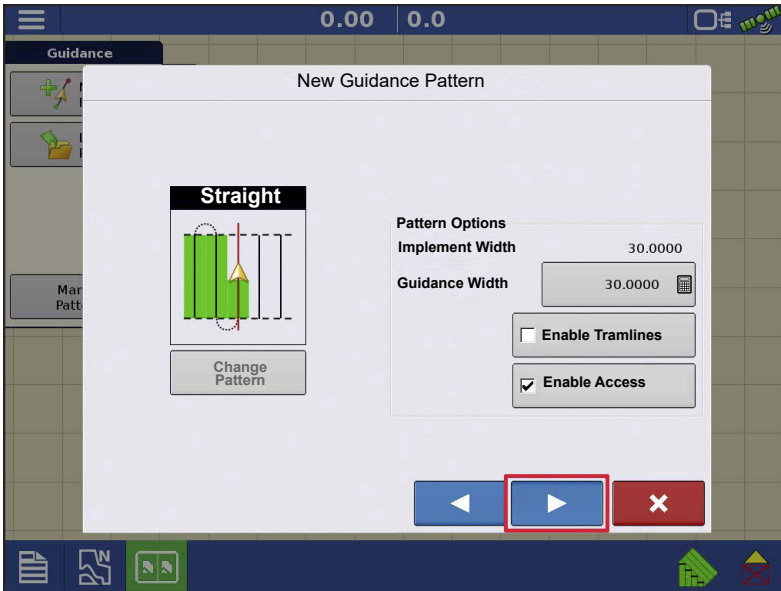
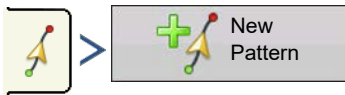

2. Check Enable Access Paths:

3. Click the right arrow to setup Access Paths.

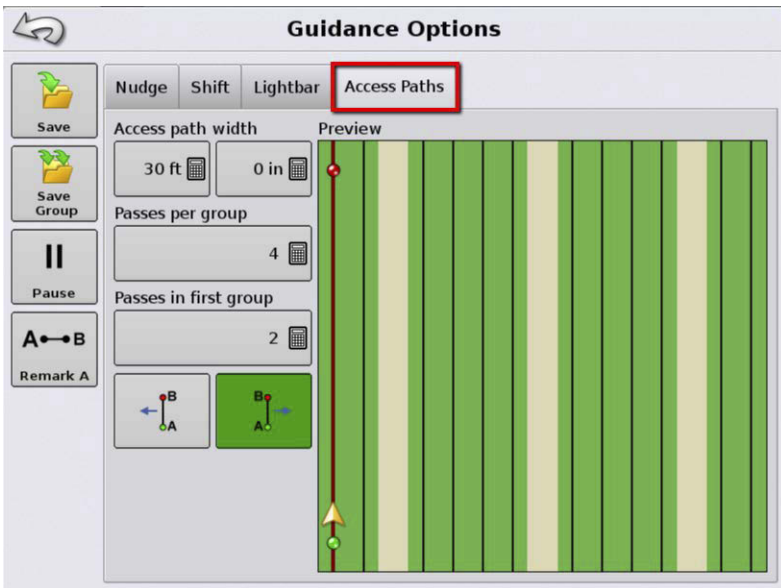

4. From the Guidance Options window select the Access Paths tab.

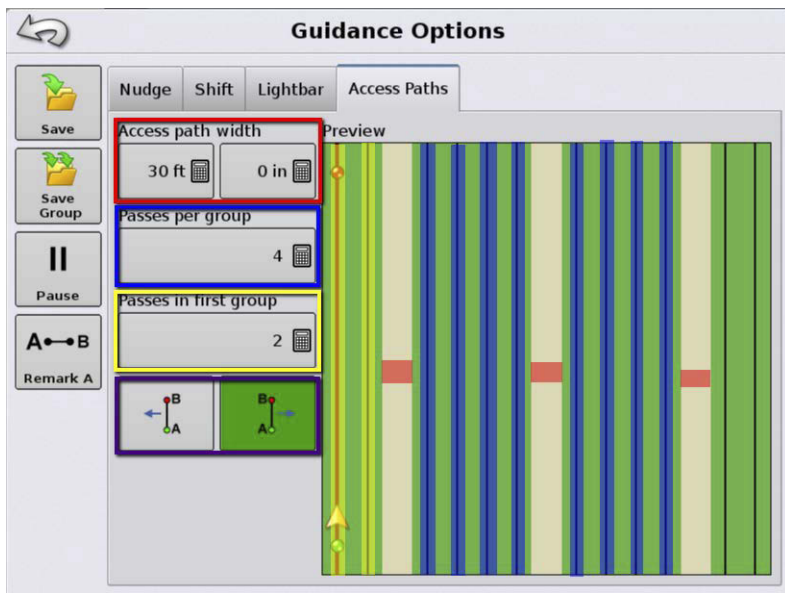

Settings on the left side of the window and how they relate to the Preview Window.

**Access Path Width** — Width of Access Path (Irrigation ditch, road)

**Passes Per Group** — Number of passes in between each Access Path

**Passes In First Group** — The first group of passes may not be equal to the other groups. This setting allows

the user to set the number of passes before the first access path.

**Move Start** — Shifts start to the left or right of the original AB line.

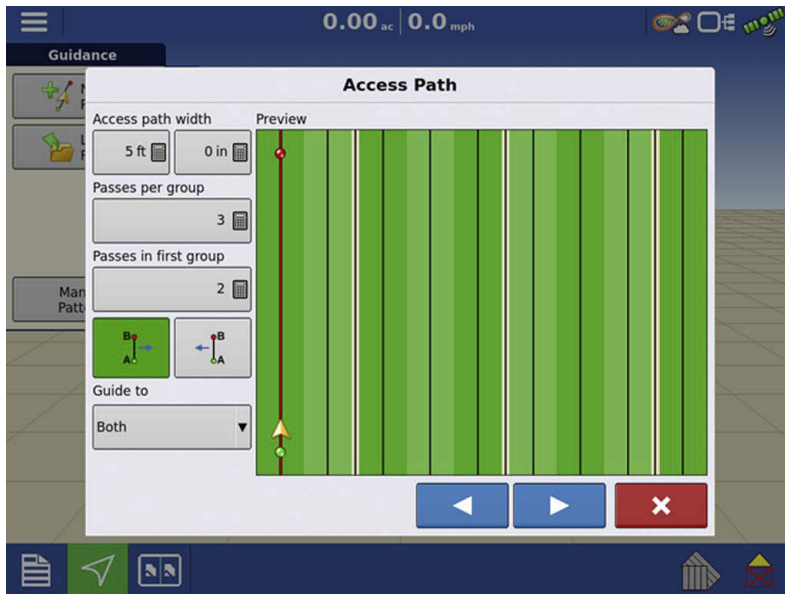

**Guide To** – Allows guidance line to be placed in the desired location (Paths, Access Paths, or Both)

## TurnPath

An automatically generated guidance path that takes you from your current guidance pass to your target pass.

### TurnPath Requirements

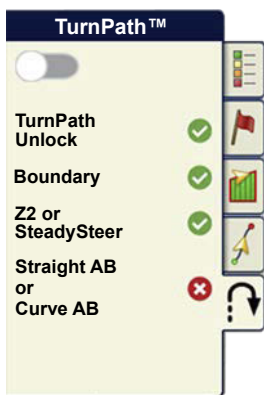

- TurnPath Unlock
  - Field boundary
  - SteerCommand Z2/SteadySteer
  - Straight AB or Curve AB guidance line
- The requirements will only show when one or more of the requirements are not met.

When one or more of the requirements are not met, TurnPath will automatically be switched off. It will need to be enabled again when requirements are met.

### TurnPath Single Turn Mode Toolbox



TurnPath on/off button

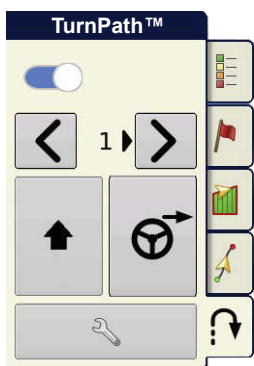

Sequence mode is disabled, and single turn mode will be used.

**Turn Direction** – Triangular indicator to show the turn direction of the next TurnPath.

**Target Pass** - Number shown to indicate the difference between the current pass number and the target pass number.

**Adjust Target Pass location** - Moving the target pass, relative to current driving direction.

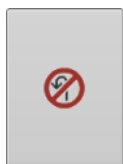

**TurnPath Cancel** – If pressed, TurnPath is canceled, and no TurnPath will be generated. The TurnPath will turn gray. When the turn is gray, it can be made active by hitting the next turn button.



**TurnPath Alarm Active** – notifying that user is within the TurnPath Countdown Distance. The button can be pressed to cancel the TurnPath.



**TurnPath Next Turn** – If pressed, TurnPath will move to the next available turn shown in gray.

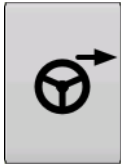

**Turn Now** – When pressed, TurnPath will immediately turn toward the target pass. Only available while using single turn mode.

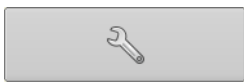

**TurnPath options** – Opens the TurnPath options

## TurnPath Preview

The TurnPath Preview tab shows a preview of the turn and allows adjustment to the parameters that define the shape and location of the turn.

Both the sliders and the number entries can be used to adjust. The value of the sliders show the live changes on the turn shape and location. The number entries are recommended to fine tune to a specific value. Pressing reset will take all sliders back to the default setting.

The preview enables evaluation of the TurnPath's shape and location, and how the TurnPath fits in the intended headland size. The vehicles with implements indicate the estimated trajectory of the implement through the turn, also shown with the dotted blue line. The three representations are shown at both the headland crossings and the halfway point of the turn.

The Max Speed shown in the preview resembles the expected maximum speed that can be used on the TurnPath. However, there are many factors playing into how well the vehicle can track the TurnPath.

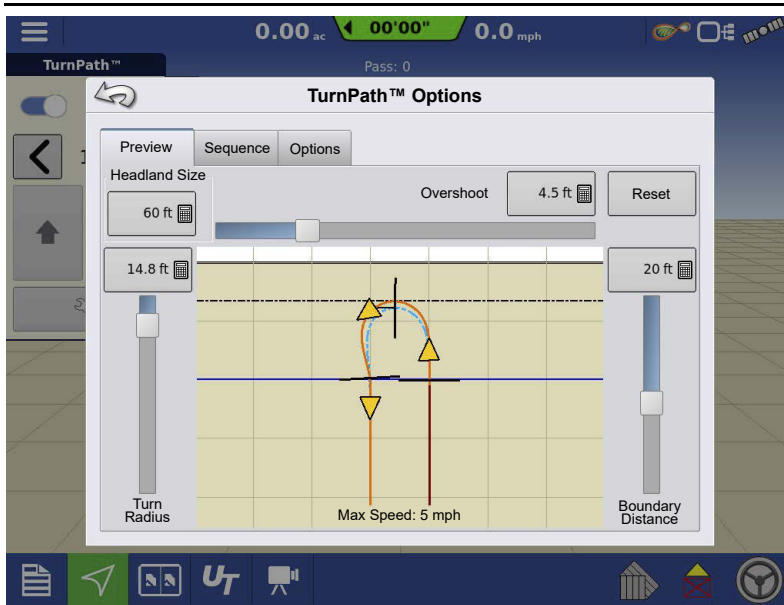

## TurnPath Radius

- The potential minimum turn radius in a TurnPath

A smaller value will lead to a sharper turn, and a larger value to a wider turn. When wanting to drive at higher speeds a larger turn radius value will be needed.

## Overshoot

- How far you will overshoot the target pass on exit of the turn

With pull type implements that trail on the inside of the turn, adding an overshoot will allow the implement to line up perfectly straight on the target pass. The more an implement trails on the inside, the bigger overshoot value needed.

## Boundary Distance

- The minimum distance from the TurnPath to the field boundary

When using a negative value, the TurnPath will cross the field boundary.

**i** **NOTE!:** In situations where the vehicle is not able to perfectly follow the TurnPath the vehicle can get closer to the field boundary than defined by the boundary distance.

**i** **NOTE!:** The solid black line in the TurnPath preview represents the field boundary.

**i** **NOTE!:** The dotted black line in the TurnPath preview represents the minimum distance the TurnPath will stay from the field boundary, the Boundary Distance.

## Headland Size

- A reference for evaluating how the previewed

---

TurnPath will fit in the intended headland size. The headland size value entered will not affect the shape or location of the TurnPath.



**NOTE!:** The solid blue line represents the headland size in the TurnPath preview.

## Reset

- Will reset the defaults for Turn Radius, Overshoot, and Boundary Distance

The Headland Size will not be reset.

## TurnPath Options



### Auto Flip Direction

- Will automatically flip the direction of the turn based on the driving direction.

Unchecking this option will maintain the current turn direction, the user will adjust turn direction, and target pass manually.

### Countdown Distance

- The distance from the turn at which the user will be alarmed on the upcoming TurnPath.
  - There is an audible alarm at this time.
  - The TurnPath toolbox will automatically slide open.
  - The cancel button will be showing a GIF to draw attention to the cancel option.

### Initial Turn Option

- Option used when the guidance line has multiple encounters with the external boundary.
  - **First Turn** – TurnPath will complete the turn at the first encounter with a boundary.
  - **Last Turn** – TurnPath will complete the turn at the last encounter with a boundary.



**NOTE!:** No TurnPath will be generated on internal boundary.

## Sequence Mode

Sequence Mode defines a plan to work the field using a fixed order of guidance passes, a Sequence. The Sequence characteristic, the fixed, planned, order of passes, is defined by the Sequence settings, and the base pass on which the sequence is created.

In Sequence Mode the active guidance pass is defined by the Sequence progress, this applies when engaged, and when disengaged. In Sequence Mode the active guidance pass will not automatically update when travelling through the field. This behavior is fundamentally different to the behavior when not using TurnPath or when using Single Turn Mode, where the active guidance pass is defined by the vehicle location.

Sequence Mode is designed to follow a fixed, planned, order of guidance passes. The Sequence progresses to the next guidance pass in the order of guidance passes when a TurnPath is started. Alternatively, the Sequence rolodex next button can be used to progress to the next guidance pass, or the rolodex previous button can be used to return to previous guidance pass.

### Sequence Mode Toolbox & Rolodex

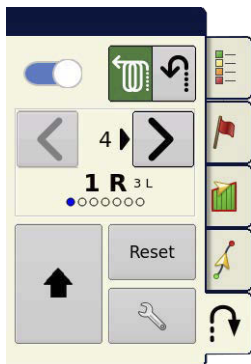

Sequence mode is active.

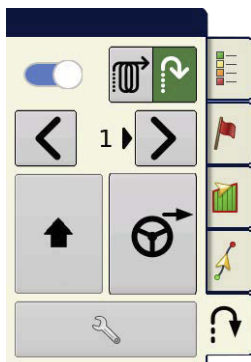

Sequence mode is enabled, but single turn mode is active.

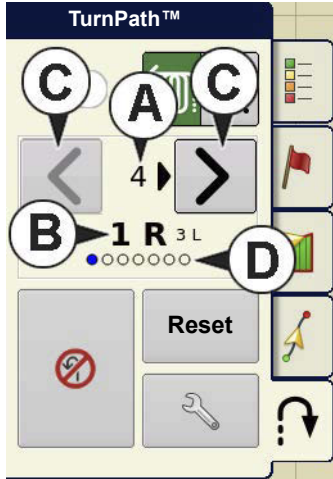

A. Target Pass direction

and Target Pass number

B. Previous pass in sequence (left)

current Pass in sequence (center)

next pass in sequence (right)

C. Rolodex button , move to next or previous pass in sequence

D. LED indicates current state in sequence group. Total number of LEDs resembles amount of passes in the current sequence group.

Blue LED indicates Sequence Base Pass. The Base Pass is the first guidance line of the first sequence group.

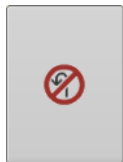

**TurnPath Cancel** – If pressed, TurnPath is canceled, and no TurnPath will be generated.



**TurnPath Alarm Active** – notifying that user is within the TurnPath Countdown Distance.



**TurnPath Next Turn** – If pressed, TurnPath will move to the next available turn



This resets Sequence Base Pass to the current vehicle location.



**TurnPath options**



## Sequences

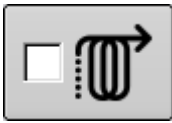

Sequence mode is disabled.



Sequence mode is enabled.

Four options that Sequences can be used:

- Identical Groups
- Alternate Groups
- Skip Pass
- Harvest

## Identical Groups

When following the sequence, all groups in the sequence will be identical.

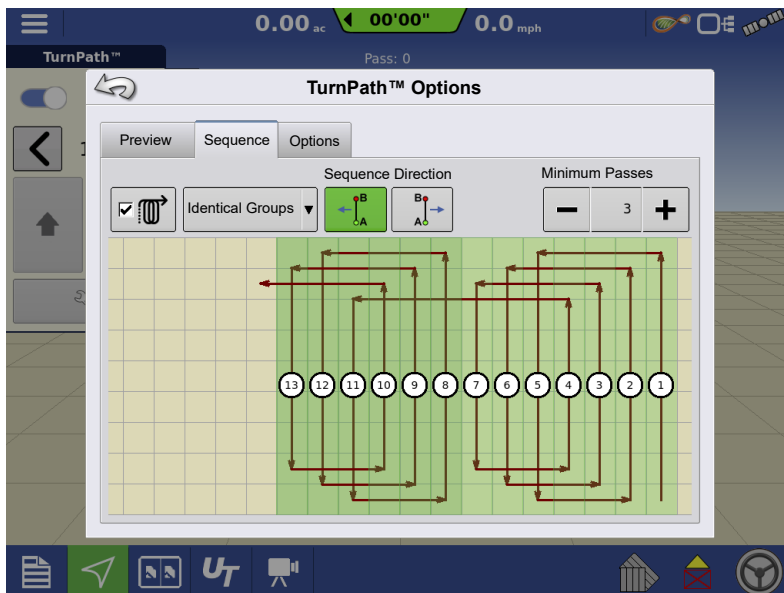

•**Sequence Direction** – Direction relative to the A-B direction for populating sequence groups.

•**Minimum Passes** – Minimum target pass setting for the sequence group.

## Alternate Groups

When following the sequence, when moving to a next group, the turning direction will alternate.

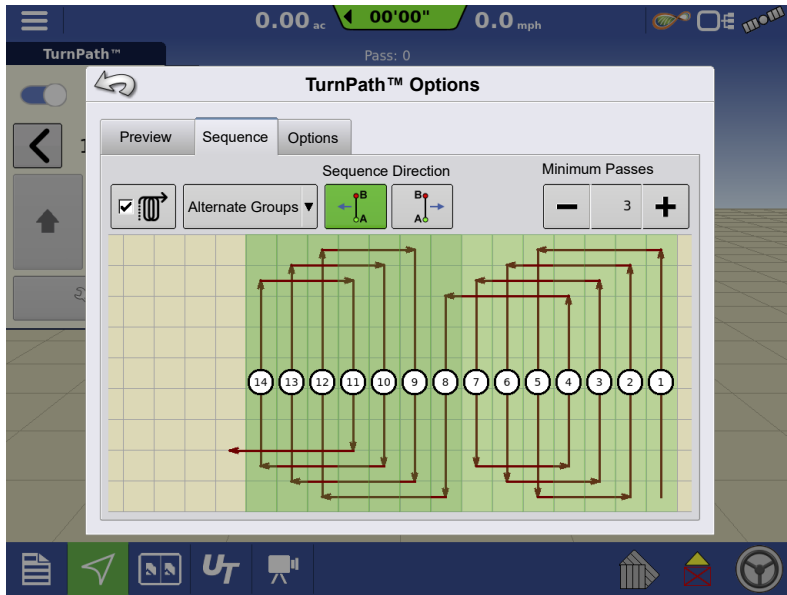

- **Sequence Direction** – Direction relative to the A-B direction for populating sequence groups.
- **Minimum Passes** – Minimum target pass setting for the sequence group.

## Skip Pass

An efficient preset order to move through the field with switching between a target pass of 2 and 3. Used when the turn to the next pass is too sharp, and a single pass needs skipped.

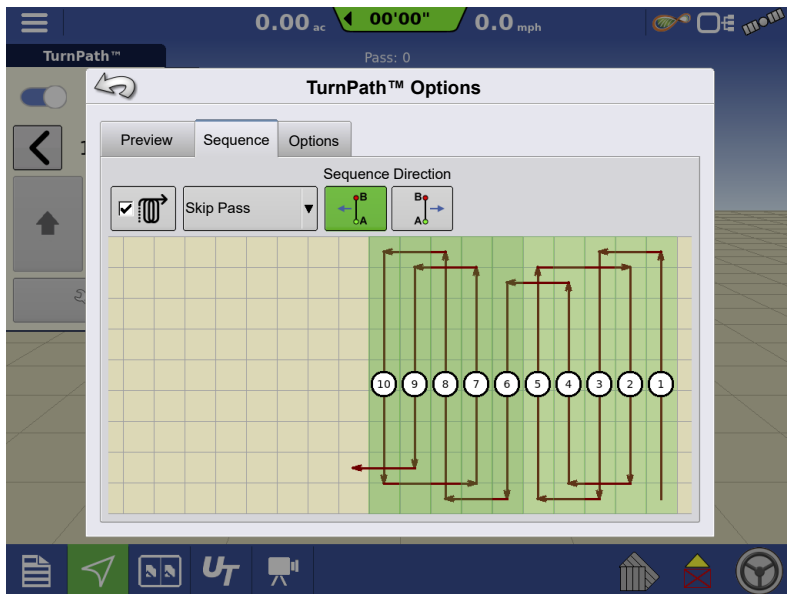

- **Sequence Direction** – Direction relative to the A-B direction for populating sequence groups.

## Harvest

Sequence designed for harvest operations, to unload on one side of the vehicle, over already harvested ground. Select to go inward or outward throughout the field.

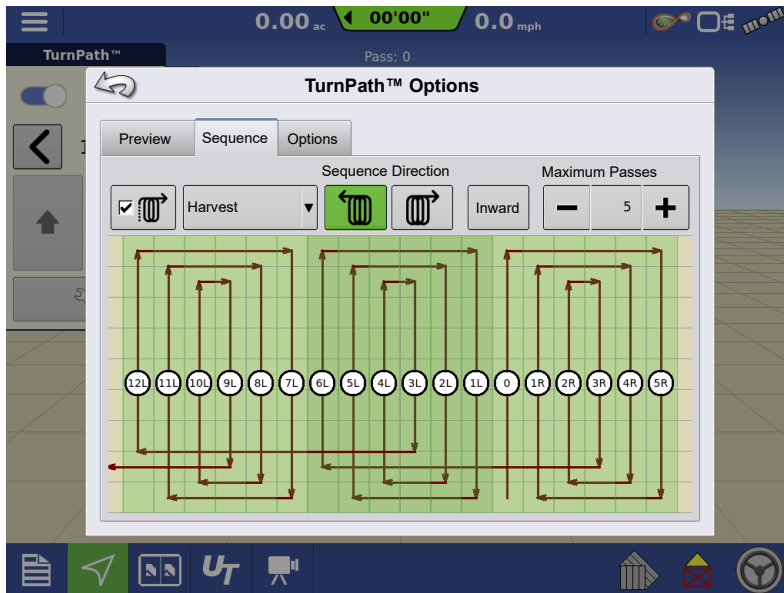

- **Sequence Direction** – Direction relative to the A-B direction for populating sequence groups.

- **Maximum Passes** – Maximum target pass setting for the sequence group.

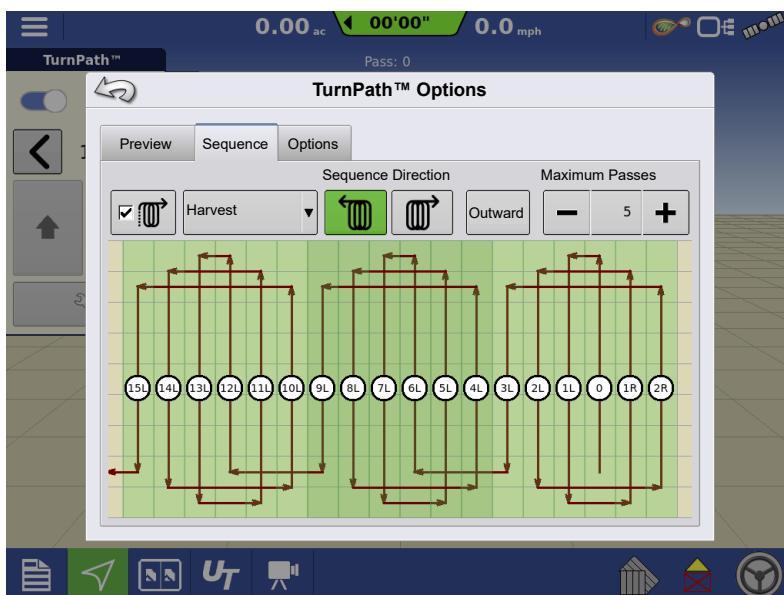



## Summary Report



Summary Report

Season: 2014 Crop | Grower: Ag Leader | Farm: Farm 1

Field: North | Operation: Liquid | Product: Water

Region	Avg Rate	Total	Area	Date Created	View Mode
Instance 1	11.8	18.9	1.60		Agronomic
<1>	11.8	18.9	1.60	07/22/2015	
Field Total (All)	11.8	18.9	1.60		

Buttons: Create Report, View Report, View Map

This screen shows field totals and averages. Use the drop-down menus at the top to specify the information needing viewed.

Specific information is shown in the list below for each:

- Season
- Grower
- Farm
- Field
- Operation
- Product

The list displays information for each Region and Instance.

There are four viewing modes:

- Agronomic
- Event
- Operator
- Configuration

Summary Report

Season: 2014 Crop, Grower: Ag Leader, Farm: Farm 1

Field: North, Operation: Liquid, Product: Water

Region	Avg Rate	Total	Area	Date Created	View Mode
Instance 1	11.8	18.9	1.60		Agronomic
<1>	11.8	18.9	1.60	07/22/2015	
Field Total (All)	11.8	18.9	1.60		

Buttons: Create Report, View Report, View Map

The Agronomic View shows data of a specific field.

Summary Report

Season: 2014 Crop, Operation: Liquid

Event: 2015-07-22\_10:41:32, Product: Water

Region	Avg Rate	Total	Area	Date Created	View Mode
Instance 1	11.8	110.3	9.37		Event
<1>	11.8	110.3	9.37	07/22/2015	
Field Total (All)	11.8	110.3	9.37		

Buttons: Create Report, View Report, View Map

The Event View shows data of a specific Event.

Operator View

# Summary Reports

Summary Report

Season: [Dropdown] Operator: [Dropdown] Operation: [Dropdown]

Start Date: July 22, 2015 End Date: July 22, 2015

Region	Avg Rate	Total	Area	Date Created
[Empty Table]				

View Mode: Operator

Buttons: Create Report, View Report, View Map

- Shows data of a specific Operator
- Filters data by each configuration used by the selected operator.

- Area Only
- Daily Subtotals
- Configuration Total
- Operator Total

Summary Report

Season: 2014 Crop Operation: Liquid Configuration: Tractor

Start Date: July 22, 2015 End Date: July 22, 2015

Date Created	Grower	Farm	Field	Area
07/22/2015				
2015-07-22_10:41:32	Ag Leader Farm		North	9.37
			Subtotal	9.37
			Total Area	9.37

View Mode: Configuration

Buttons: Create Report, View Report, View Map

- Shows data of a specific configuration

- Area Only
- Daily Breakdown
- Daily Subtotals
- Configuration Total

## Date Range

Start Date: June 10, 2014 End Date: June 12, 2014

- View data in a certain date range.
- Only used in Operator or Configuration view.
- Defaults to first and last day of logged data in the season.
  - Can only select days within that date range.
- Create Report button will create all Smart Reports within the defined date ranges.

---

## Event Summary



The event summary page allows the user to access productivity information specific to the current event as well as summary information, field notes, and Smart Reports.

The Event Summary page is available during any field operation.



A. Productivity Information

B. Summary Reports

C. Field Notes

D. Display Totals

E. Field Totals

## Field Notes

The Field Notes button is where the following agronomic information is entered:

- Crop information
- Application timing
- Weather information
- Soil condition

## Conditions

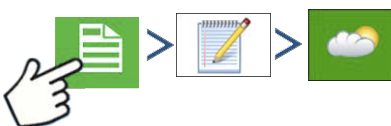

## Weather



- Sky Condition
- Wind Direction
- Wind Speed
- Air Temperature
- Humidity

## Soil Conditions

- Tillage Type
- Crop Residue Level
- Soil Condition
- Soil Moisture
- Soil Temperature

## Crop Timing

- Operation Timing
- Target Crop Type
- Growth Stage

## Equipment

Equipment attributes specific to operation being performed



## Product

Product attributes specific to operation being performed

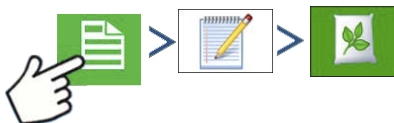

## Memo

Press  to input, edit, or delete Field Notes.

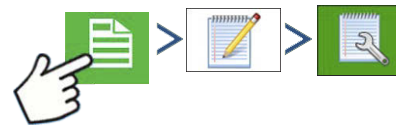
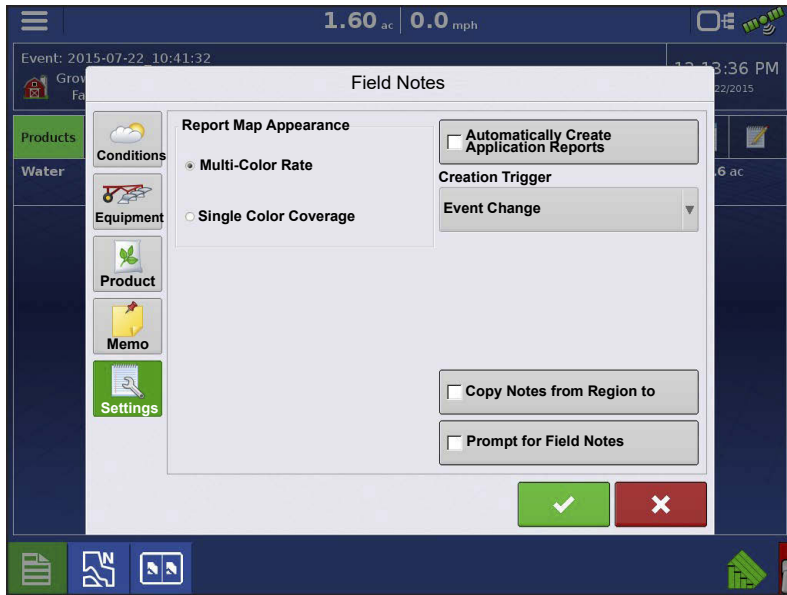
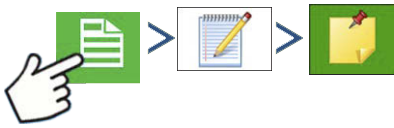

Change settings that affect the creation of application reports.

- **Auto Generate Application Report**

Check this option to have the display automatically generate an application report each time a new event is started.

- **Copy Notes from Previous Region**

Check this option to copy all values already specified in Report Details for the previous region over to a new region.

- **Prompt for Field Notes**

Check this option to have the display automatically launch the region summary data collection dialogue box each time a new region is created during application rate control.

- **Report Map Appearance**

- **Multi-Color Rate**

Select this option to have application reports display the application maps using rate legend as displayed on the Mapping screen.

- **Single Color Coverage**

Select this option to have the application reports display single color product coverage maps.

## Smart Reports™ (InCommand™ 1200 Only)

Smart Report™ creates documentation of all in-field product application events. This documentation is saved in a Portable Display Format (PDF) to USB or AgFiniti®. This PDF either can be viewed on the display screen, or printed later. Smart Reports provide information relating to location, product information, applied totals, field areas, as-applied maps and field boundaries.



**NOTE!:** Enter any necessary information in field notes before creating a Smart Report.

### Create Reports



To begin creating a Smart Report™, first highlight an item in the list on the Summary Report screen, then press the Create Report button.

1. The Create Report screen appears, which lists at top:

- Grower
- Field
- Product

Two drop-down menus list:

- Operating Configuration
- Product Group

Use the drop-down menus to change these, if desired. Press  when finished.

2. A scroll bar displays progress made when the display compiles the Smart Report.

3. At the conclusion of the Smart Report creation process, a screen states “Report Creation Complete.”

Press  or press the View Report button to view the report. A built-in PDF viewer displays Smart Report. An example is shown at [Control Channel Report Content on page 201](#).



**NOTE!:** Subsequent pages in the Smart Report are visible by pressing the blue right and left arrows at top right. Also, zoom in and out of the Smart Report by pinching to zoom on the pdf.

## Smart Report Auto-Generation

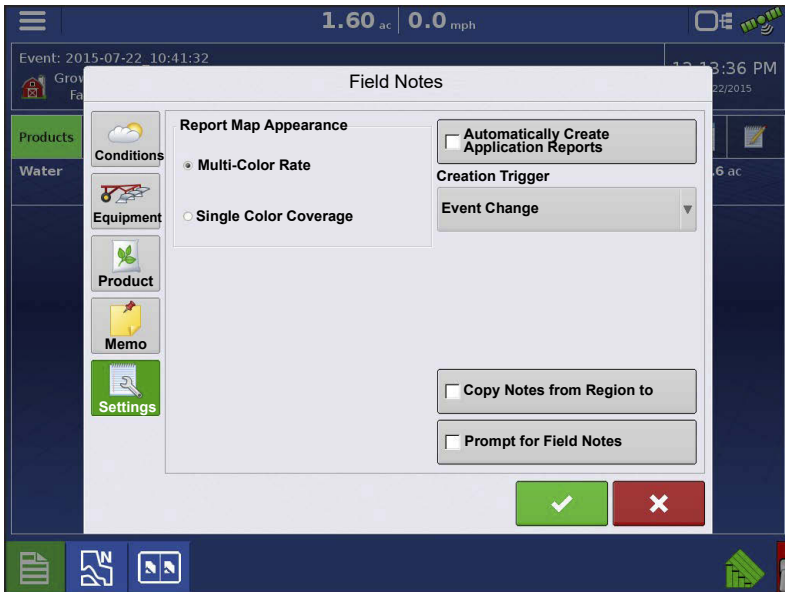

This screen allows the user to change the settings that affect the creation of application reports.

- Automatically Create Application Report checkbox

Check this option to have the display automatically generate an application report each perform the action in the Creation Trigger drop-down menu.

- Creation Trigger drop-down menu

User can select to generate reports upon Event Change or Event Closed.

If changing products through the field, it is recommended to set the Prompts to Close Event checkbox in Event Options.

## Export Reports

Reports are stored locally within the display and must be manually exported to a connected USB or AgFiniti. This can be done by pressing “Export Reports” on the Data Transfer page.

See “Export Reports” on page 57.

## Control Channel Report Content



Grower Ag Leader		Field Field: North      Farm: Farm 1 County              Description: Township Range Section			
Equipment Configuration Vehicle: Tractor Implement: Boom Height:		Application Timing: Placement: Nozzle PN: Boom		Application Date/Time Start Time: 07/22/2015 11:20 AM End Time: 07/22/2015 12:19 PM	
Product: Water Applied Area: 9.37					
Rate: ■ ■ ■ ■ ■					
Crop Crop: Growth		Restrictions Crop Rotation Restricted Entry Interval		Target Pests	
Product Summary					
Name			Restrictions		
Water	Manufacturer	EPA #	RUP No	Amount	Average Rate
				110.29	11.76
Operator/Supervisor Information					
Operator:				License:	
Operator:				License:	
Supervisor:				License:	

North\_Tractor.Sprayer\_121513\_2015\_07\_22.pdf

Page 1 of 2

The content of all product application reports is divided into two distinct groups.

The first page(s) of the report represent field and product control channel specific information.

In cases of multiple product application, multiple pages will be generated, one for each channel of product control.

REGION SUMMARY		
Item	Region 1	Region 2
Region Name	<1>	
Operator Name		
<b>Application Details</b>		
Area	80.80 ha	
Map Amount	1356.72 L	
Pell Lime Amount	902.33 L	
Application Start Time	12/17/2009 3:20 PM	
Application End Time	12/19/2009 10:20 AM	
<b>Soil Conditions</b>		
Soil Temperature	15 ° C	
Soil Moisture Level	Wet	
Soil Condition	Medium	
Crop Residue Level	High	
Tillage Type	Strip Till	
<b>Environmental</b>		
Air Temperature	15 ° C	
Wind Speed	10 km/h	
Wind Direction (From)	NE	
Sky Condition	Partly Cloudy	
Humidity	11 %	
<b>Additional Information</b>		
Memo		

2\_JD 8440\_CM 7000\_111731\_2013\_07\_09.pdf

Page 2 of 2

Control Channel Content includes the following:

- Service Provider Information
- Grower Information
- Field Information
- Farm Name and Description
- Equipment Configuration Information
- Application Information
- Date/Time Information
- Crop Information

- Rotation Restrictions and REI
- Multiple Target Pests
- Applied Product Information
- Operator and Supervisor Information

## View Reports



To view Smart Reports that have been saved on USB drive, go to the Summary screen and press the View Reports button. At the File Selection screen, scroll down the list and select the PDF file of Smart Report.

Press  and the Smart Report will appear in the PDF viewer.

## View Map

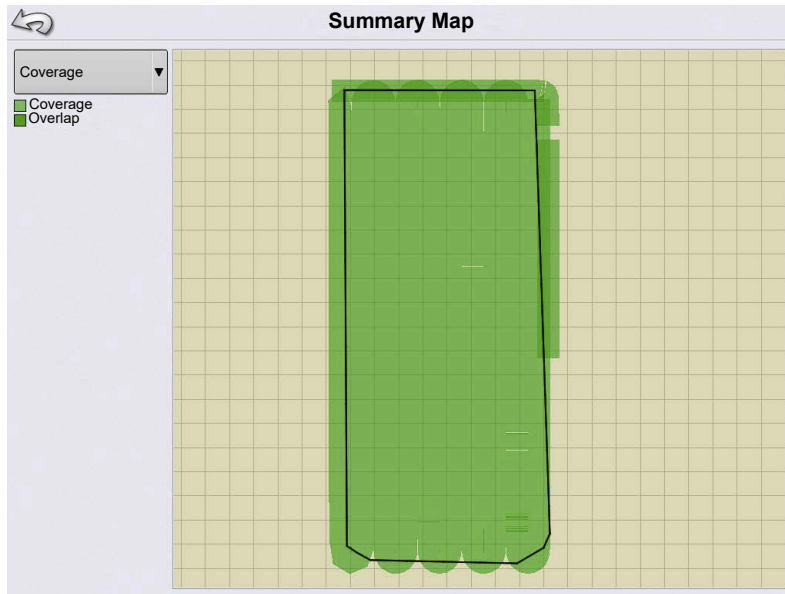

To view a Summary Map of a particular Field Total, Region or Instance shown in the Summary Report.

A Summary Map appears. This map shows the rate applied for Application operations and varieties for Planting operations.





## Enable the Universal Terminal

### ISOBUS Settings

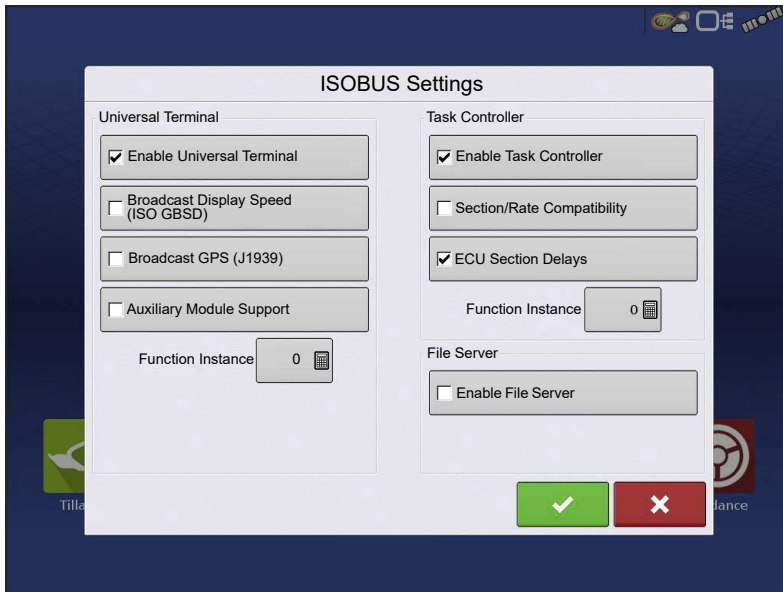

### Universal Terminal

The display is compatible with the ISO 11783 (ISOBUS) Universal Terminal Standard. This enables support of many ISOBUS compliant implements on the display. Universal Terminal functionality enables the compliant implement's user interface to be viewed and controlled on the display.

Once Universal Terminal has been enabled, it will appear in the task bar.

Toggle between the Universal Terminal screen and other display functions by pressing the UT button.

### Task Controller

The InCommand™ displays have the ability to use ISOBUS Task Controller on compatible ECU's. This allows the InCommand display to control rate and sections of an ISOBUS ECU using Ag Leader's proprietary interface. A properly setup display configuration is required for this to work.

### ISO Load and Go

With a properly setup ISO ECU, ISO Load and Go streamlines the configuration building process for task controller ECU configurations. The Load and Go feature automatically builds a controller during the configuration building process based on the ECU device description. For this to work it requires the device description to have proper sections, section offsets, and product type setup on the ECU.



**NOTE!:** Maximum of 144 sections supported with 3rd party ECU's.

## File Server

Diagnostic logging for the troubleshooting of Hardi Sprayers.

## Common Terminology

**ISOBUS Working Set**—One or more ISOBUS modules that control an implement's functionality.

**Working Set Master (WSM)**—Main module responsible for coordinating all communication between the UT and the Working Set including loading of the Object Pool to the UT screen.

**Object Pool**—The graphic image presented to the user on the UT display. The Object Pool is sent to the UT by the ISOBUS module.



**ATTENTION!:** Before operating an ISOBUS implement with the display, read the

operator's manual provided by the implement's manufacturer and follow all safety information provided in the manual. When this display is used with an ISOBUS implement, the information and functions on the display are provided by the implement ECU and are the responsibility of the implement manufacturer.

**Broadcast Display Speed (ISO GBSD)**—Checking this box allows speed source currently being utilized by the display to be broadcast over the ISOBUS to the implement ECU.

**Broadcast GPS (J1939)**—Checking this box allows GPS data being supplied by the GPS receiver to be broadcast over the ISOBUS to the implement ECU.

**Auxiliary Module Support**—Checking this box allows the Ag Leader Auxiliary Input Module or Smart Switchbox, to be used with ISOBUS ECUs that support AUX-N auxiliary functions.

**Universal Terminal Functional Instance**—Always set to 0 except when there are multiple UTs on the ISOBUS. Use to change instance. Reboot Display.

**Section/Rate Compatibility**—This setting determines how often the Display target rate message is sent to the ISOBUS ECU.

- When unchecked, the target rate message is only sent when it is changed on the display.
- When checked, the target rate message is sent at regular intervals. This is a non standard ISOBUS setting. Leave this setting off unless ISOBUS ECU has an issue with the target rate resetting to zero on its own.

# Ag Leader Display–Auxiliary Assignments

**ECU Section Delays**—Determines the manner in which mapping delays are handled with ISOBUS ECUs.

- When checked (default), mapping delays are determined by ISOBUS ECU and the “look-ahead” interval stored in the Ag Leader display. Leave this checked when using DirectCommand Gen2 ISO Liquid.
- When unchecked, mapping delays are determined by the “look-ahead” interval stored in the Ag Leader display. This method is thought of as industry standard and is used by various manufacturers. Leave this unchecked when on ground AutoSwath performance is correct but display mapping is showing gaps/overlaps.



**NOTE!:** Enabling/disabling this setting does not effect on-ground section performance.

**Enable File Server**—Enables Hardi Sprayer specific diagnostic logging for troubleshooting purposes.

**Task Controller Function Instance**—Always set to 0 except when there are multiple TCs on the ISOBUS. Use to change instance. Reboot Display.

## Auxiliary Assignments

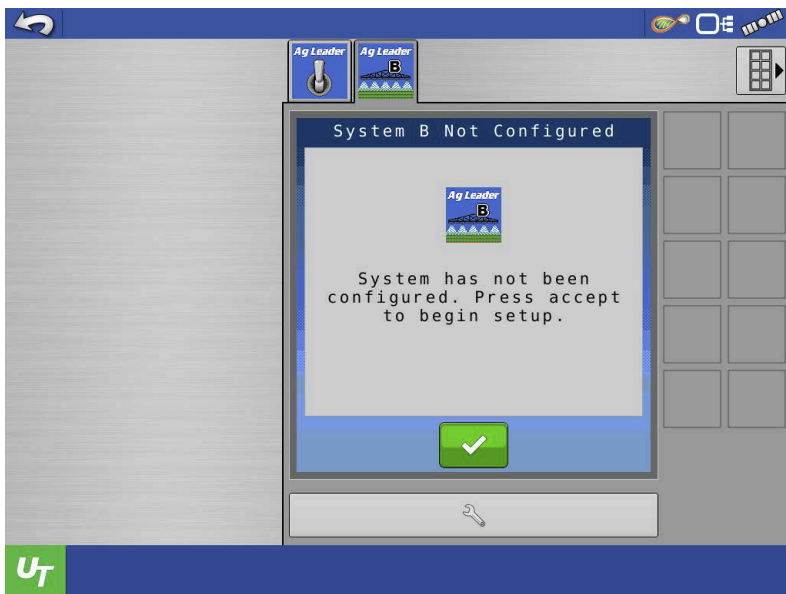

Once modules and cabling are connected the system will load an object pool for the SC7 Switch Console and an object pool for the WSM Liquid Rate Control Module shown by pressing:



Once loaded the WSM Liquid Rate Control Module will first need to be configured for the implement the

system is installed on.

Once configured the Auxiliary Controls will need to be Configured within the UT setup.

Select:

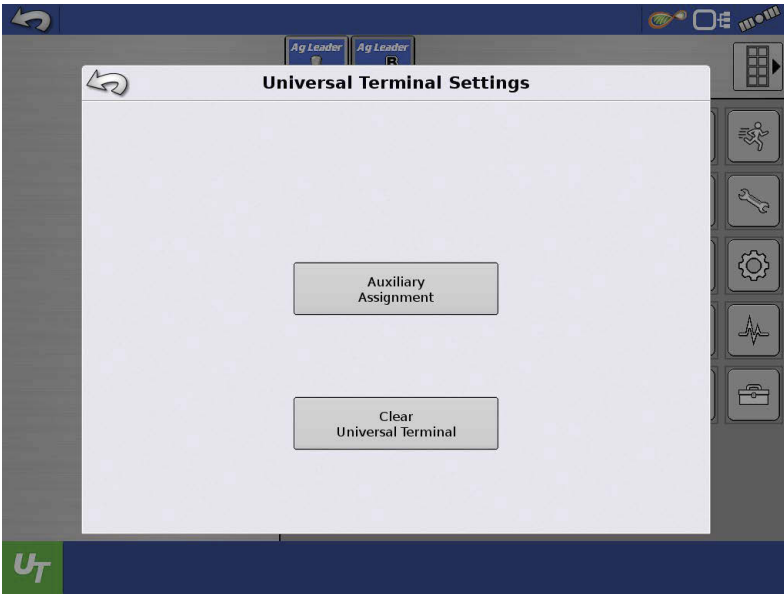

Select the Auxiliary Assignment Button.

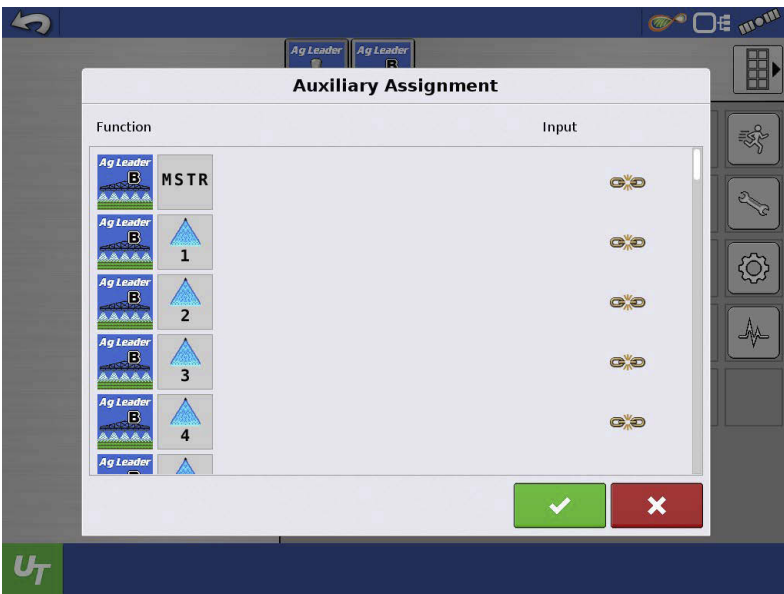
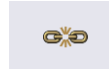

Select the disconnected chain button.

# Ag Leader Display–Auxiliary Assignments



Select the appropriate input for the desired function.



The Auxiliary Controls should look like the following images when finished.



When using the SC7 Switch Console, the Rate Change and Increase/Decrease toggle switches can be assigned to a function. To assign these toggle switches, scroll down the Auxiliary Assignment page to locate the corresponding icons. Press the disconnected chain icons to assign the appropriate input. (See images on the right)



Press  when finished.

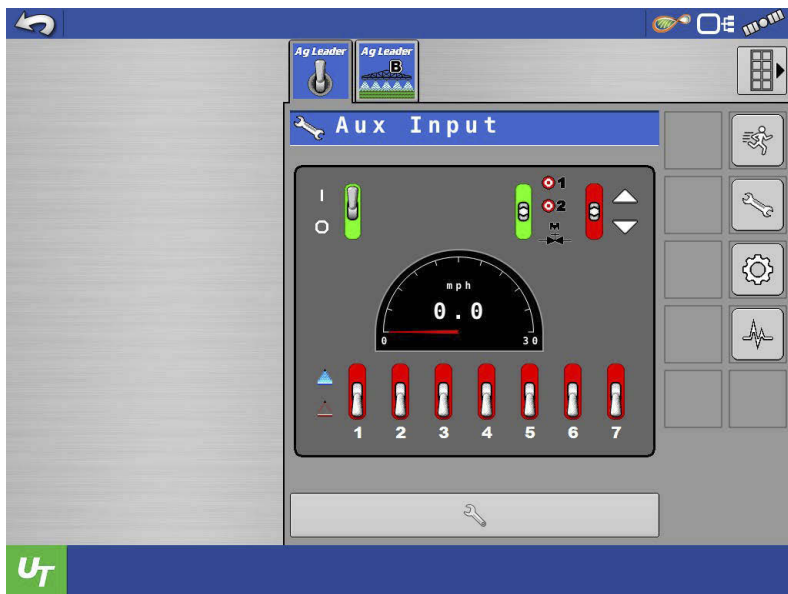

The system can be tested by accessing the SC7 Switch Console Object Pool.

- Press the UT Button.
- Press the Ag Leader Switch Button.

If the switches are configured properly the switch status in the SC7 Switch Console Object Pool will be as shown in this image.

Red = Switch Off or in Neutral

Position.

Green = Switch On or Activated by the Operator.

# Ag Leader Display–Auxiliary Assignments

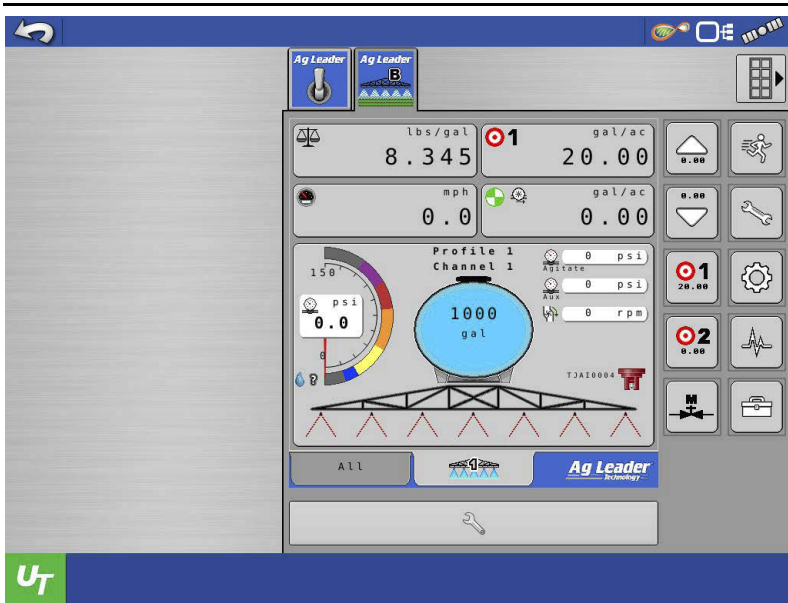

The system can also be tested by accessing the WSM Liquid Rate Control Object Pool.

Press the Ag Leader System A/System B Button to access the WSM Liquid Rate Control Object Pool.

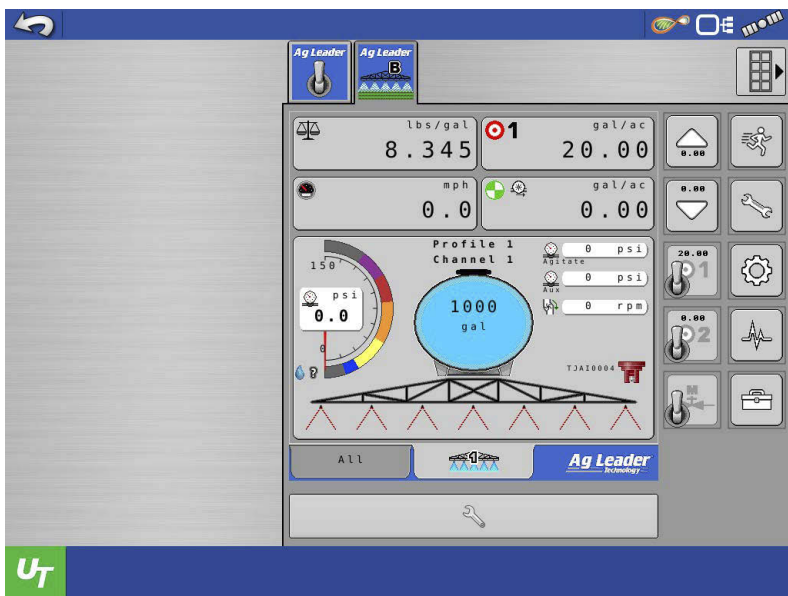

The system will indicate functions are configured to the switch box by the buttons being grayed out and a switch icon placed within the button as shown in the following image.



## Auxiliary Module Support

An Ag Leader display also supports the use of the CAN-A Auxiliary Input Module to control an ISOBUS ECU's Auxiliary Functions. The ISOBUS ECU needs to support AUX-N auxiliary functions. Follow the below steps to setup the Auxiliary Assignments for a WSM ISO Liquid Rate Control module.

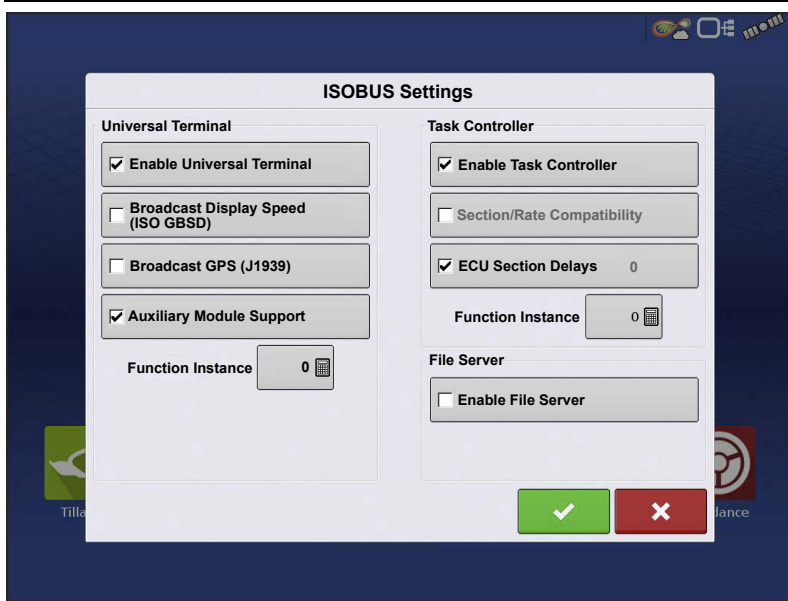

In the ISOBUS Settings, checkmark the Auxiliary Module Support box.

- A System must first be setup for the WSM Liquid Rate Control.
- Then proceed to the Auxiliary Assignment screen on the UT screen.
- Select the disconnected chain buttons to assign an input to a function.



**i NOTE!** If the Auxiliary Assignment screen is blank, attempt to cycle power on the display. Once the inputs (switches) are assigned, it will look similar to the screen shown on the left.

**i NOTE!** Auxiliary Controls (Rate 1 and Rate 2 function, increase/decrease toggle function)

cannot be assigned to a switch on the Auxiliary Input Module.

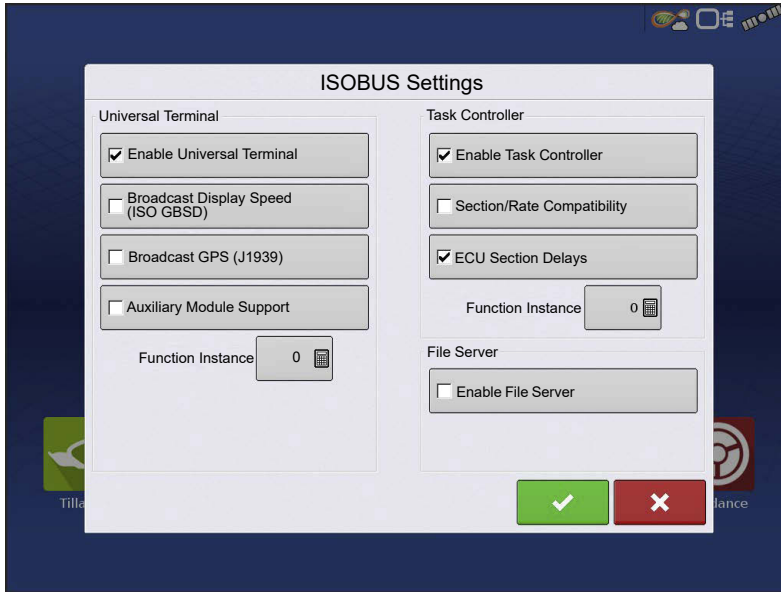

## ISOBUS Settings

**Universal Terminal**

The display is compatible with the ISO 11783 (ISOBUS) Universal Terminal Standard. This enables support of many ISOBUS compliant implements on the display. Universal Terminal functionality enables the compliant implement's user interface to be viewed and controlled on the display. Once Universal Terminal has been enabled, it will appear in the task bar.

Toggle between the Universal Terminal screen and other display functions by pressing the UT button.

**Task Controller**

The InCommand™ displays have the ability to use ISOBUS Task Controller on compatible ECU's. This allows the InCommand display to control rate and sections of an ISOBUS ECU using Ag Leader's proprietary interface. A properly setup display configuration is required for this to work.

**ISO Load and Go**

With a properly setup ISO ECU, ISO Load and Go streamlines the configuration building process for task controller ECU configurations. The Load and Go feature automatically builds a controller during the configuration building process based on the ECU device description. For this to work it requires the device description to have proper sections, section offsets, and product type setup on the ECU.



**NOTE!:** Maximum of 144 sections supported with 3rd party ECU's.

---

## File Server

Diagnostic logging for the troubleshooting of Hardi Sprayers.

## Common Terminology

**ISOBUS Working Set**—One or more ISOBUS modules that control an implement's functionality.

**Working Set Master (WSM)**—Main module responsible for coordinating all communication between the UT and the Working Set including loading of the Object Pool to the UT screen.

**Object Pool**—The graphic image presented to the user on the UT display. The Object Pool is sent to the UT by the ISOBUS module.



**ATTENTION!**: Before operating an ISOBUS implement with the display, read the operator's manual provided by the implement's manufacturer and follow all safety information provided in the manual. When this display is used with an ISOBUS implement, the information and functions on the display are provided by the implement ECU and are the responsibility of the implement manufacturer.

**Broadcast Display Speed (ISO GBSD)**—Checking this box allows speed source currently being utilized by the display to be broadcast over the ISOBUS to the implement ECU.

**Broadcast GPS (J1939)**—Checking this box allows GPS data being supplied by the GPS receiver to be broadcast over the ISOBUS to the implement ECU.

**Auxiliary Module Support**—Checking this box allows the Ag Leader Auxiliary Input Module or Smart Switchbox, to be used with ISOBUS ECUs that support AUX-N auxiliary functions.

**Universal Terminal Functional Instance**—Always set to 0 except when there are multiple UTs on the ISOBUS. Use to change instance. Reboot Display.

**Section/Rate Compatibility**—This setting determines how often the Display target rate message is sent to the ISOBUS ECU.

- When unchecked, the target rate message is only sent when it is changed on the display.
- When checked, the target rate message is sent at regular intervals. This is a non standard ISOBUS setting. Leave this setting off unless ISOBUS ECU has an issue with the target rate resetting to zero on its own.

**ECU Section Delays**—Determines the manner in which mapping delays are handled with ISOBUS ECUs.

- When checked (default), mapping delays are determined by ISOBUS ECU and the “look-ahead” interval stored in the Ag Leader display. Leave this checked when using DirectCommand Gen2 ISO Liquid.
- When unchecked, mapping delays are determined by the “look-ahead” interval stored in the Ag Leader display. This method is thought of as industry standard and is used by various manufacturers. Leave this unchecked when on ground AutoSwath performance is correct but display mapping is showing gaps/overlaps.



**NOTE!:** Enabling/disabling this setting does not effect on-ground section performance.

**Enable File Server**—Enables Hardi Sprayer specific diagnostic logging for troubleshooting purposes.

**Task Controller Function Instance**—Always set to 0 except when there are multiple TCs on the ISOBUS. Use to change instance. Reboot Display.

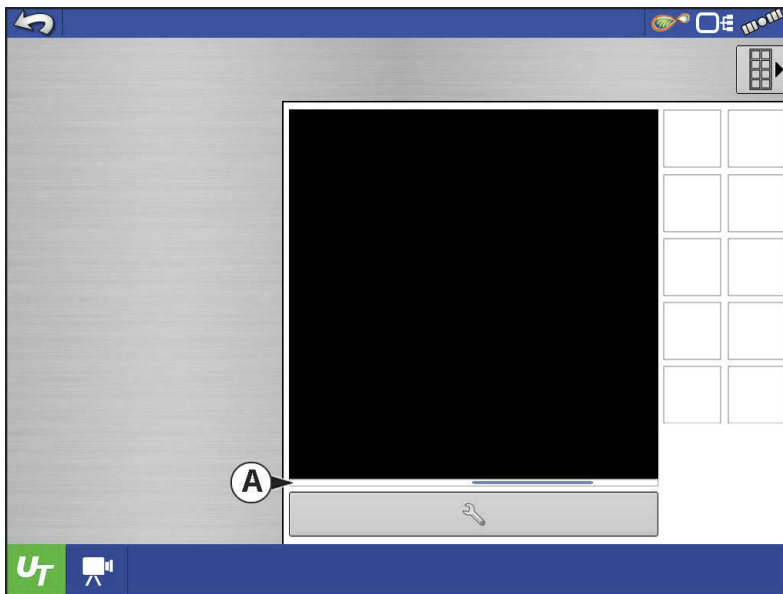

When an ISOBUS compliant implement is connected to the display for the first time, the implement WSM sends its graphic interface, called the Object Pool, to the display. The Status bar (**A**) appears while Object Pools are being loaded. This process might take several minutes depending on the number of Object Pools being loaded. Once loaded, object pools are stored in the display memory.

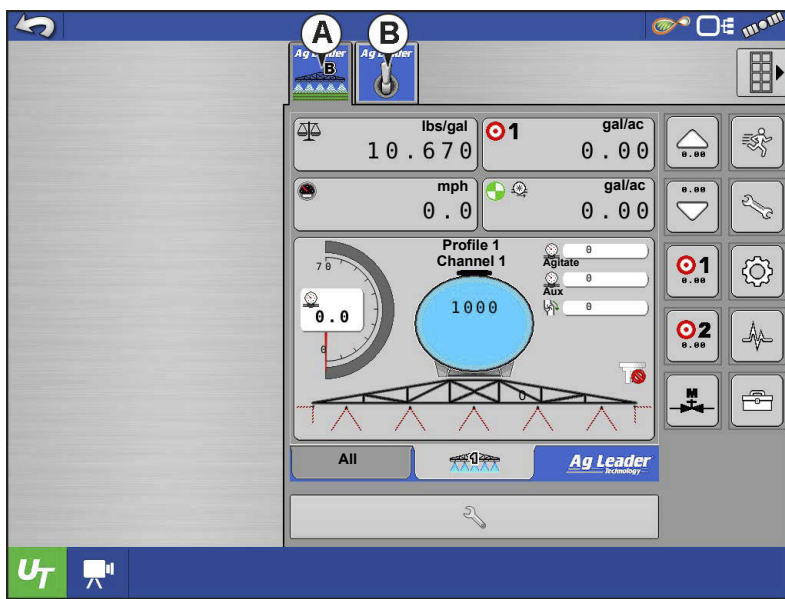

If there are multiple ISO implements connected, press the UT button  to toggle between Working Sets. The Working Sets can also be accessed by pressing tabs (A) or (B) individually.



Advance through multiple screens of buttons. This button remains hidden unless more than 10 buttons are present.



Opens the Universal Terminal Settings screen.

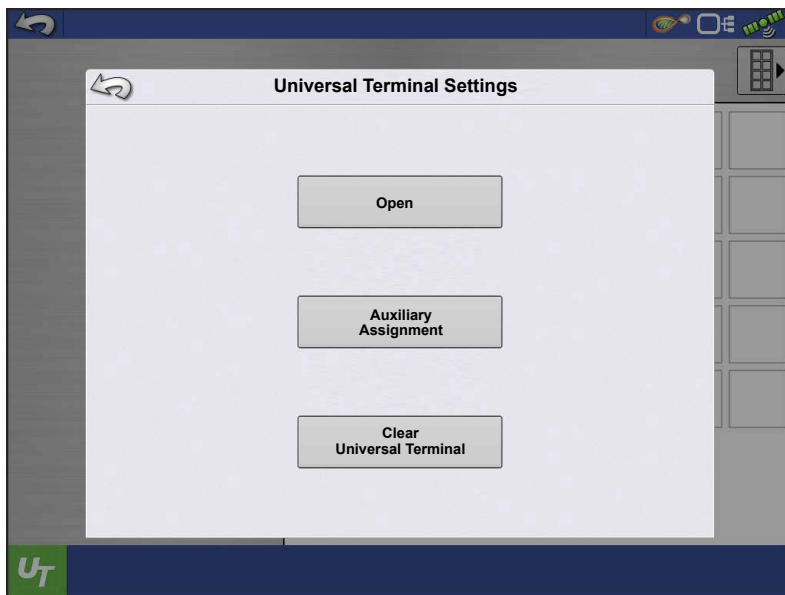

**Auxiliary Assignment**—assign implement functions to ISO compatible inputs.

**Clear Universal Terminal**—Allows operator to clear the Object Pools sent to the display from the implement WSM. After the object pools have been cleared, the next time the implement is connected the object pools will be transferred from the implements WSM to the display again.

When this button is pressed, a warning dialogue box appears with the following message:

“All Universal Terminal interfaces saved in the display will be cleared. Do you want to continue?”

## Auxiliary Assignment



Auxiliary Assignment

Assign implement functions to ISO compatible inputs.

The number of functions and inputs shown on the Auxiliary Map screens

will vary depending on the implement and input devices connected to the display.



### UT Alarms and Trouble Codes

If the display receives an active trouble code, the Universal Terminal Alarm will appear in the Status bar at the top of the screen.

When an alarm is activated on the UT, the display will indicate the alarm by flashing “Universal Terminal Alarm” in the status bar.

Alarms are acknowledged and cleared

by pressing .

This button is only present when a Universal Terminal alarm has been activated.



The Devices screen displays the following information:

- A.  indicates module has active trouble codes (DTCs)
- B. Device Class
- C. UT Manufacturer, name and code

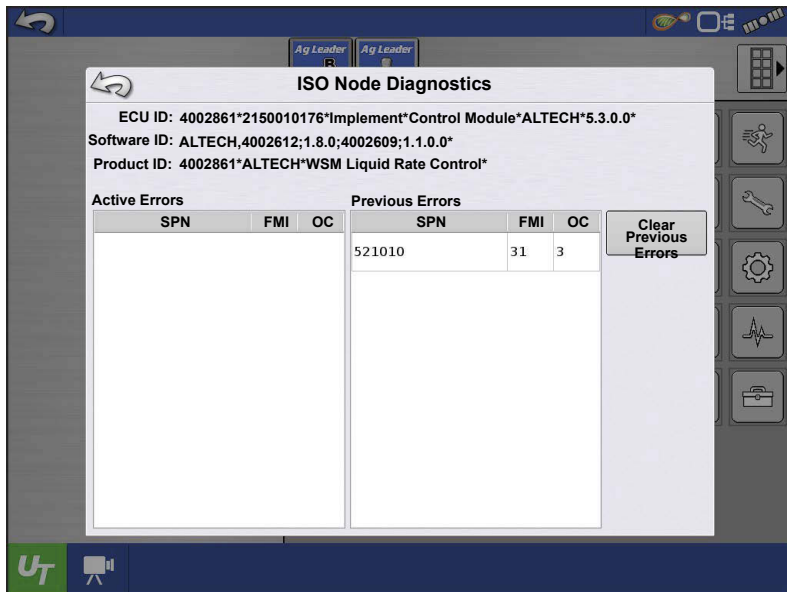

Pressing the Diagnostics button on the Devices screen brings up the ISO Node Diagnostics screen which shows the following information.

- SPN**— “Suspect Parameter Number” = Error Number
- FMI**—“Fault Mode Indicator” = Error State.
- OC**—“Occurrence Count”
- DTC**—Diagnostic Trouble Code

This is a combination of the SPN and the FMI (for example 522102.12).

Cross-reference DTC in equipment manufacturer’s operator manual for description of error.

ISOBUS Retrofit—No Modules

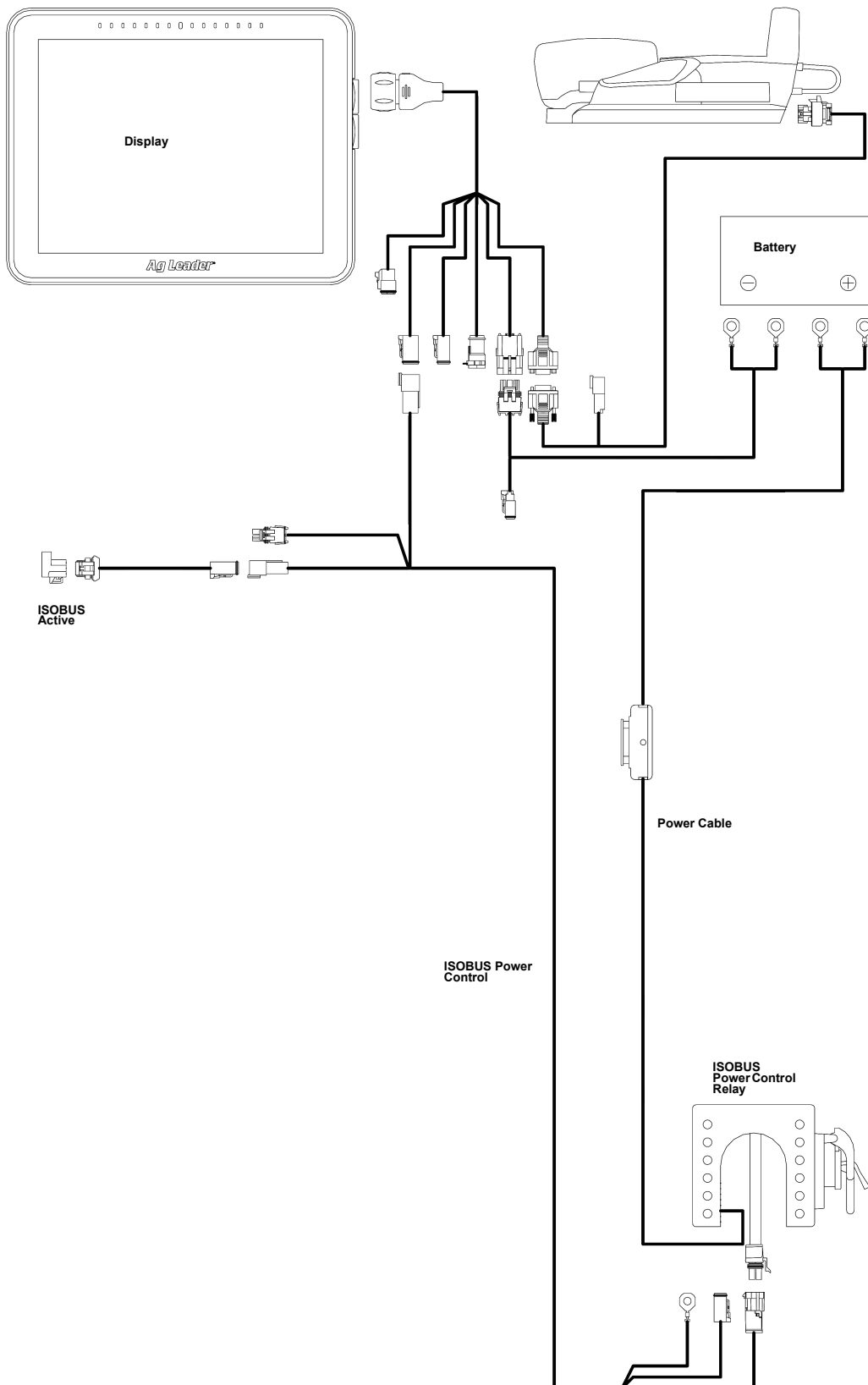

# Retrofit Cable Kit (Generic Tractor) Wiring Diagram

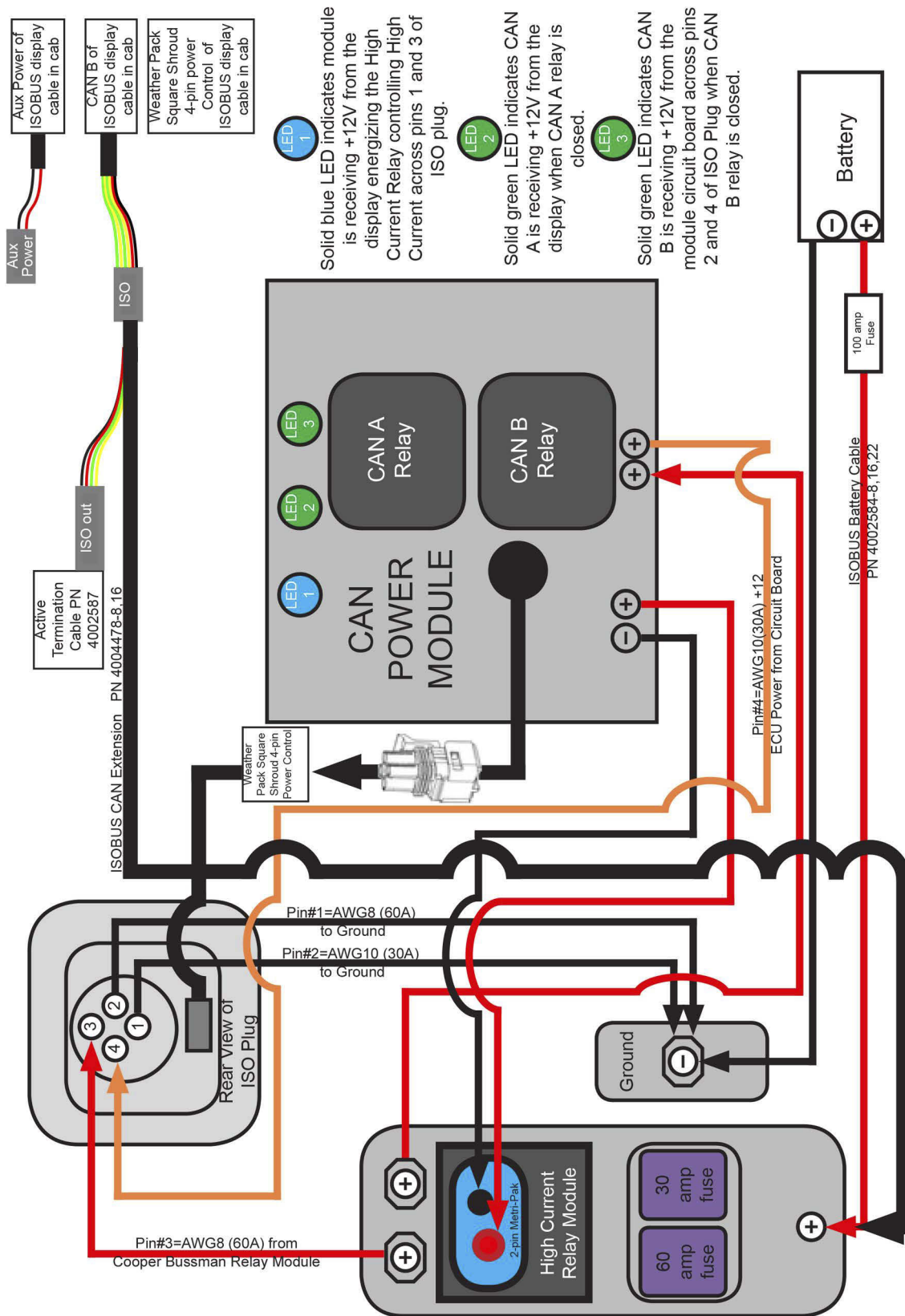



# Troubleshooting Step 1: Universal Terminal

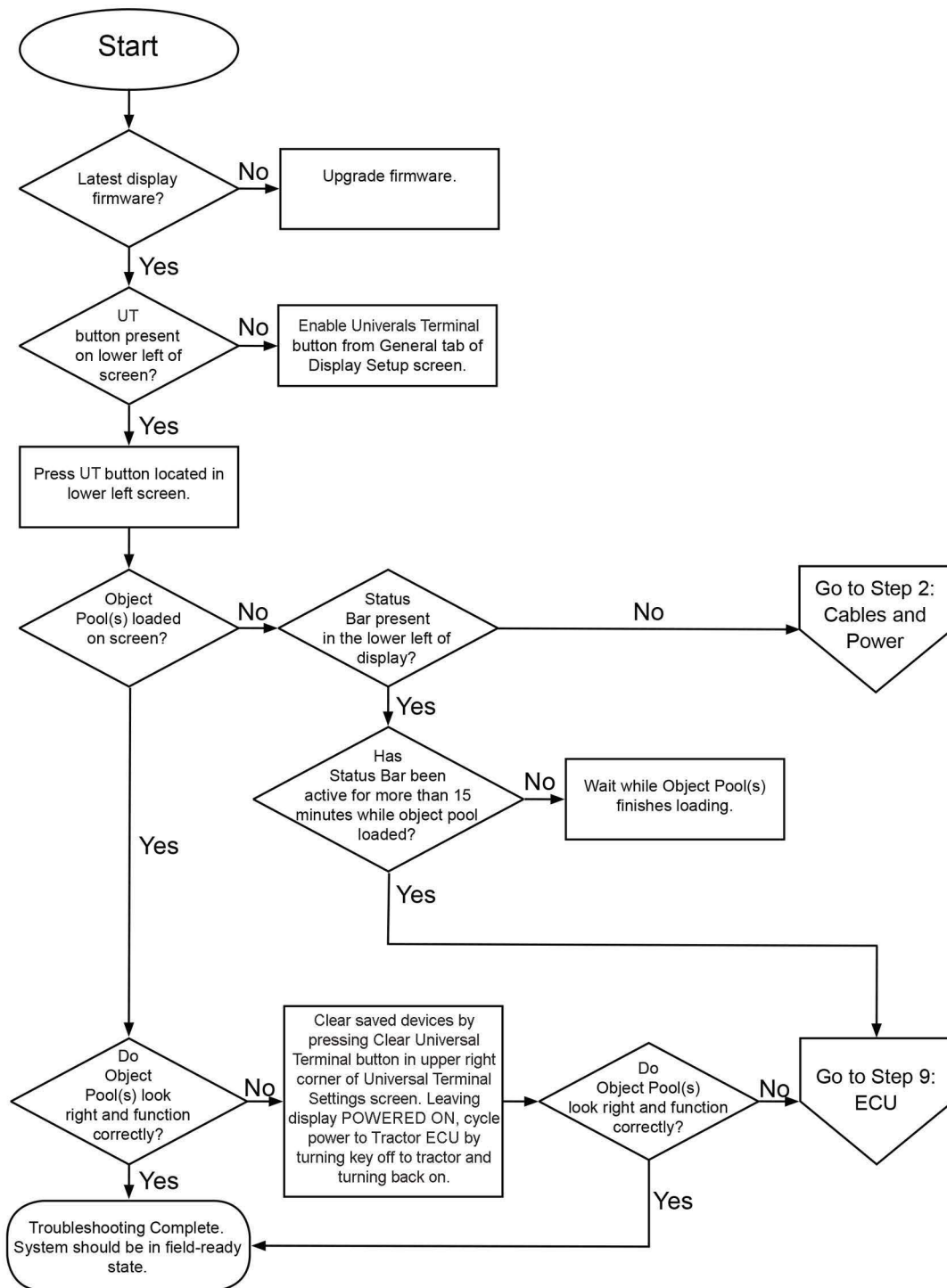

## Troubleshooting Step 2: Cables and Power

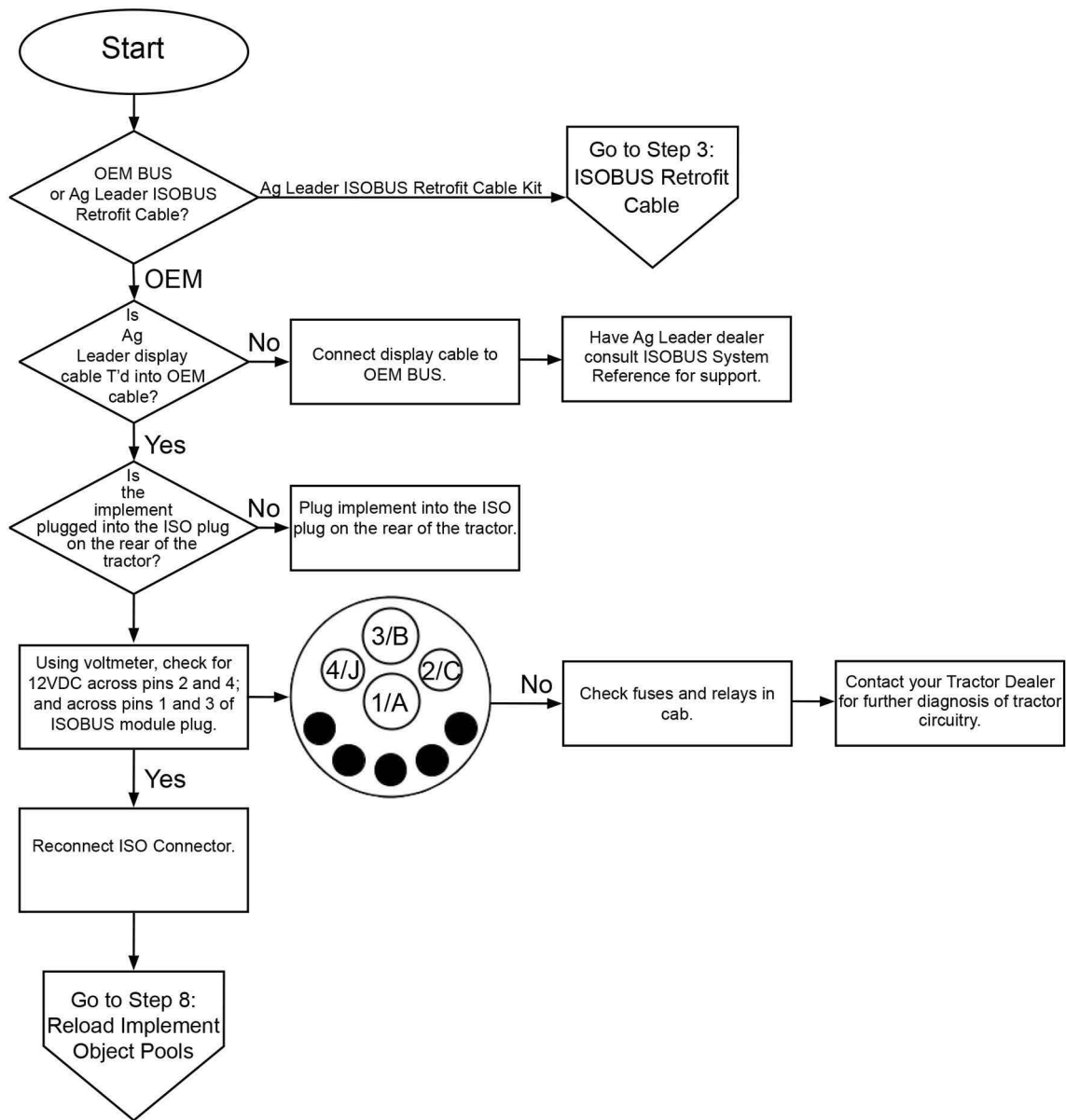

## Troubleshooting Step 3: ISOBUS Retrofit Cable

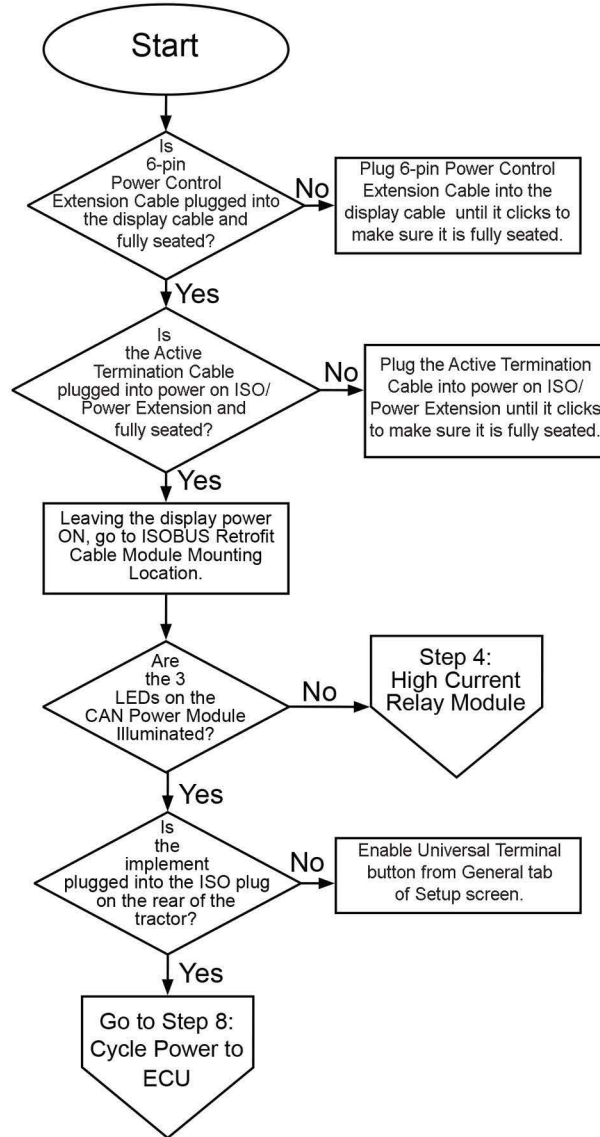

# Troubleshooting Step 4: High Current Relay Module

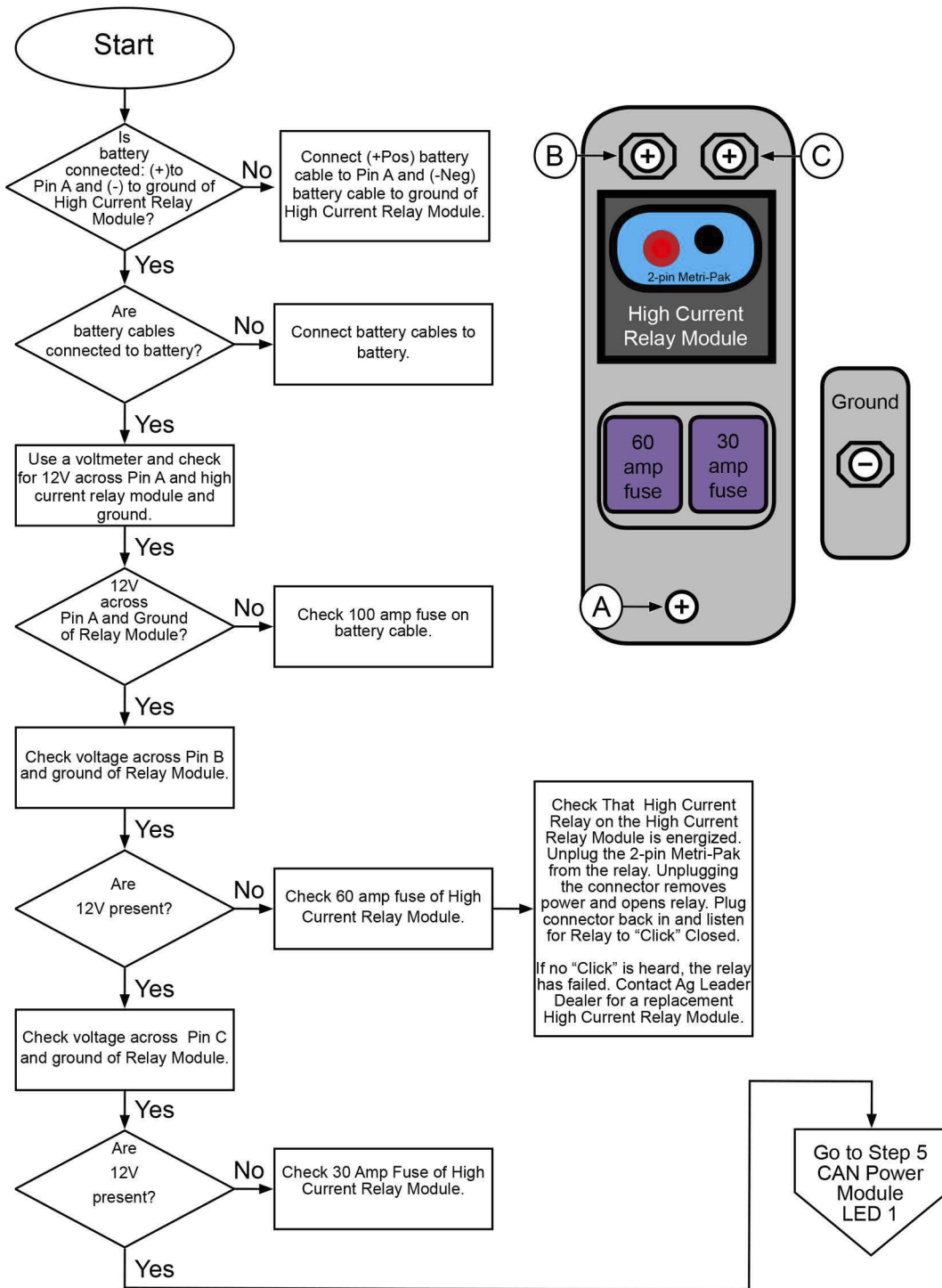

Troubleshooting Step 5: CAN Power Module LED 1

LED #1 (Blue) Indicates that the module is receiving high current power (+12 VDC) from the display energizing the High Current Relay Controlling High Current across Pins 1 and 3 of the ISO plug.

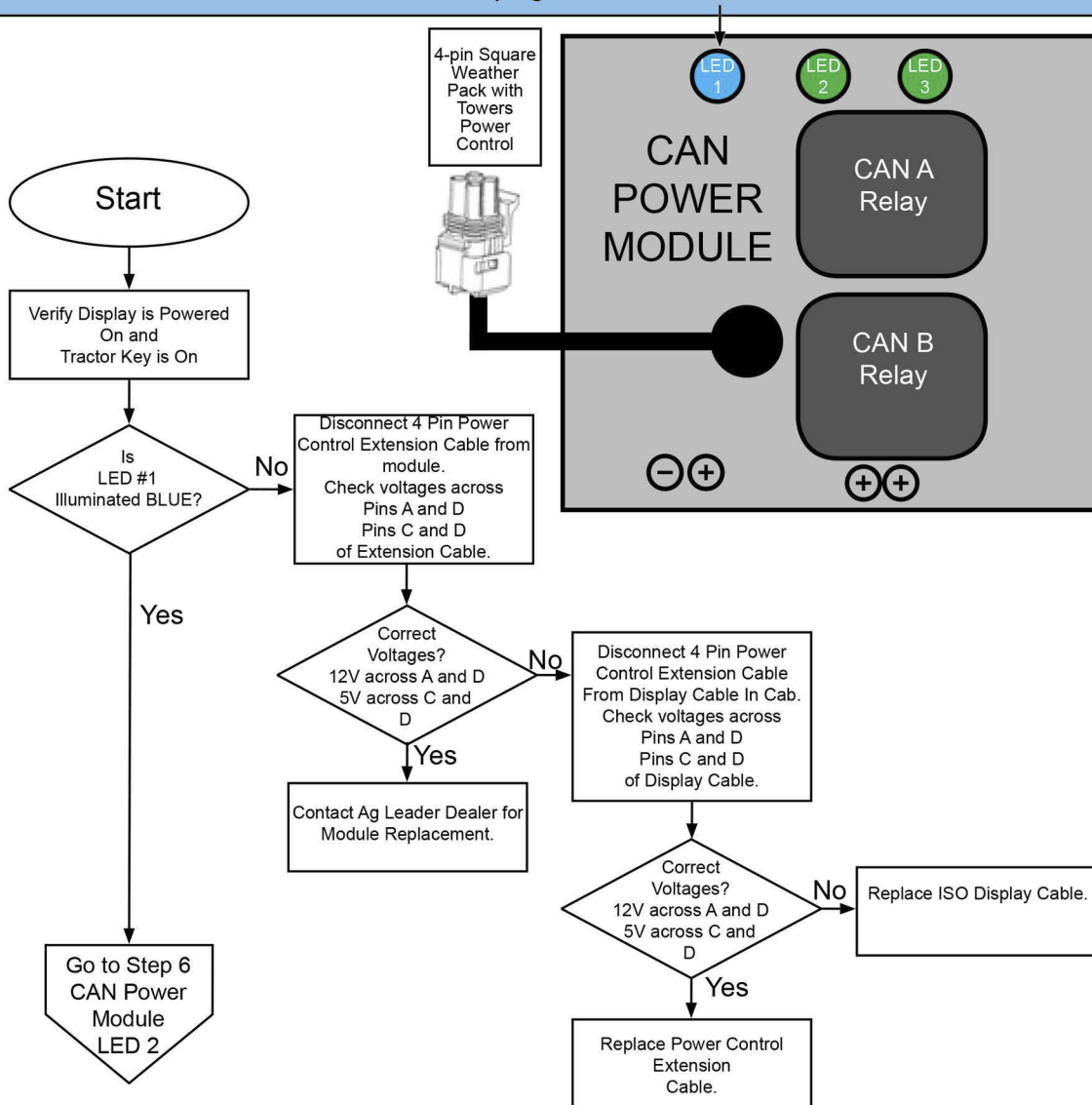

## Troubleshooting Step 6: CAN Power Module LED 2

LED #2 (Green) Indicates CAN A is being provided high current power (+12V) from the CAN A Relay of the CAN Power Module.

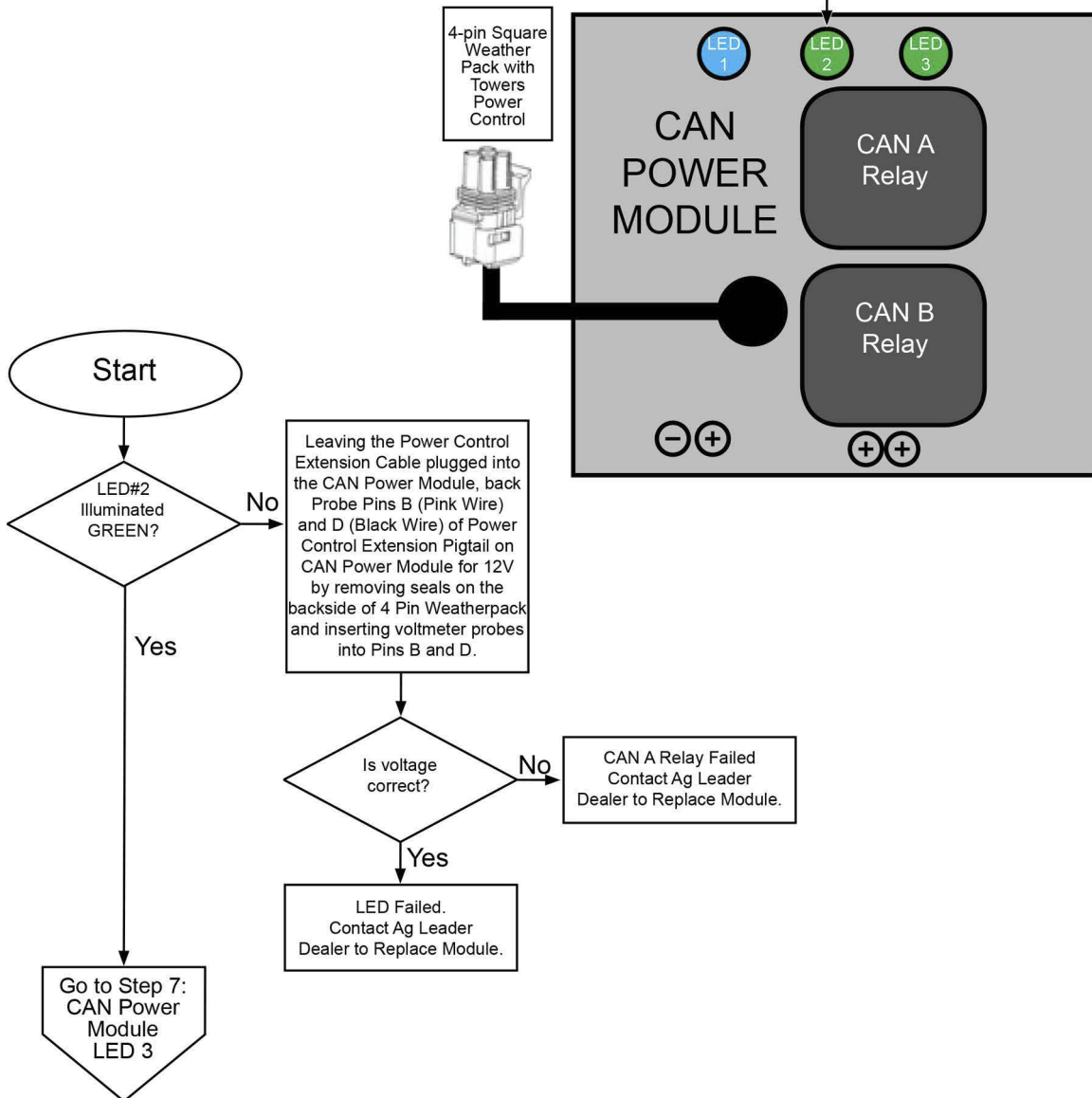

## Troubleshooting Step 7: CAN Power Module LED 3

LED #3 (Green) indicates ISOBUS/CAN B is being provided high current power (+12V) across pins 2 and 4 of ISO Plug from CAN B relay.

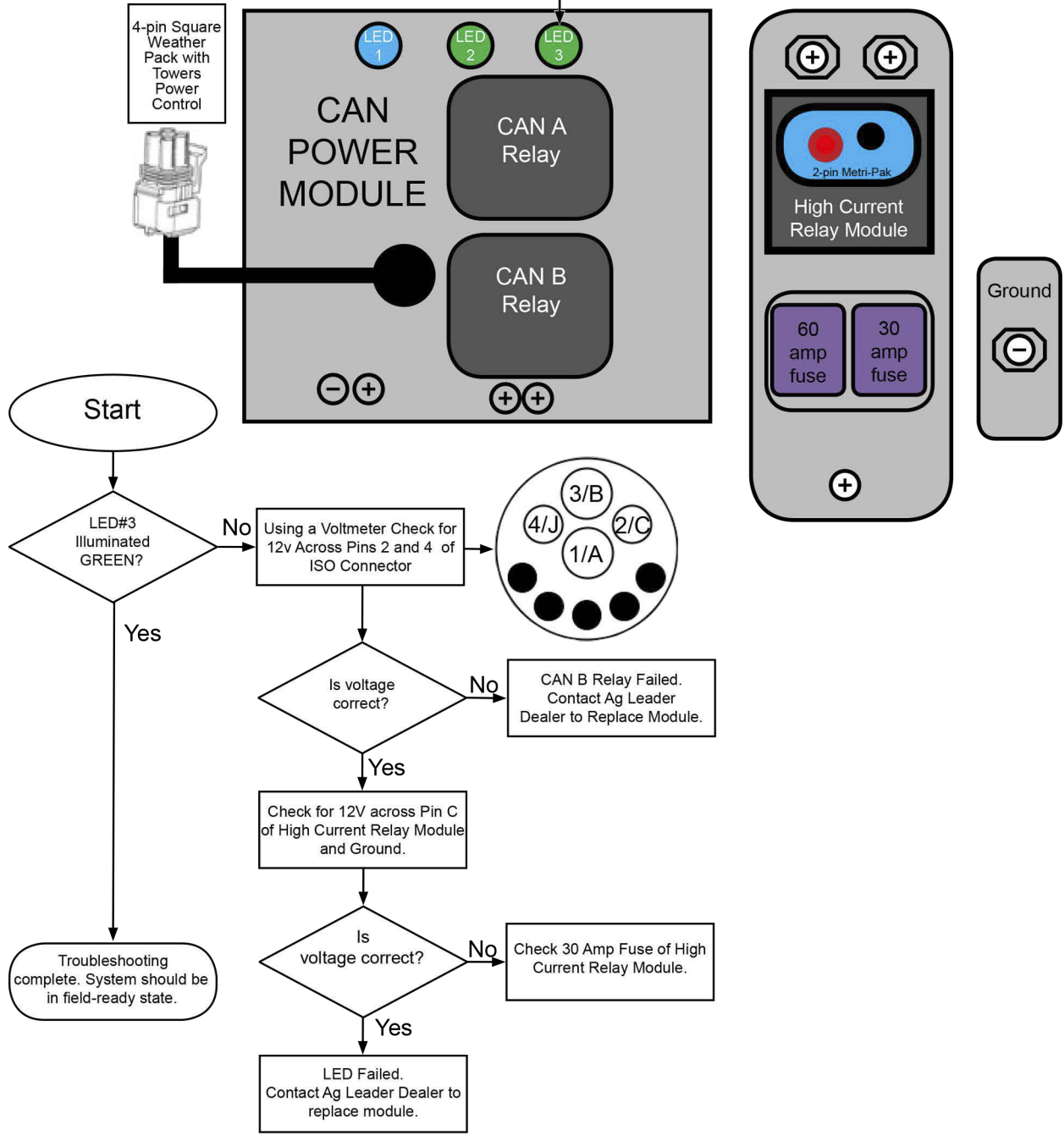

# Troubleshooting Step 8: Reload Implement Object Pools

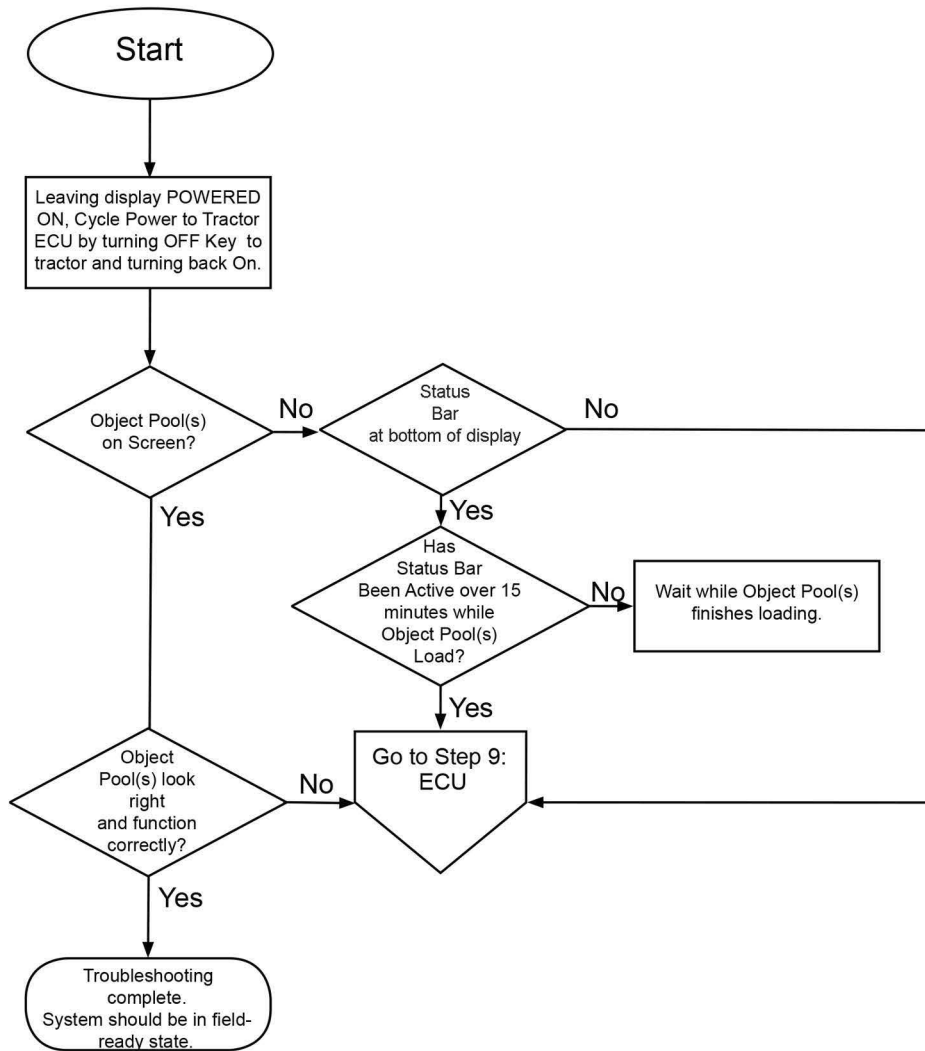



## Troubleshooting Step 9: ECU Troubleshooting

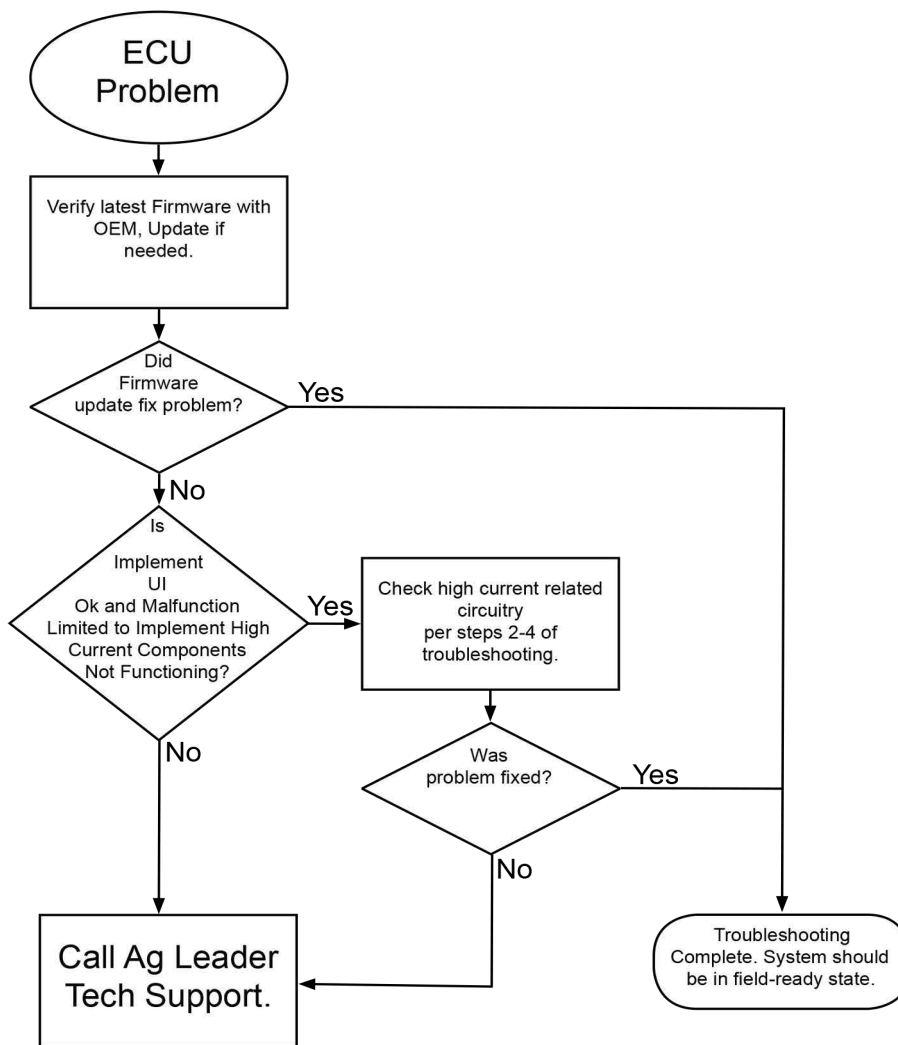



---

## Intellislope® Tile Plow Control System

### Installation

#### Components and Identification



#### Display

The InCommand™ display will mount in the cab. Use the provided cables in the cable kit to install power direct to the battery terminals, routing them out of the way, and clear of moving parts. Use the provided zip ties, to secure the cables. Coil excess cables in an area that will not get caught on moving parts. A RAM mount is provided to mount the display in

the cab, and allows for flexibility to install where windows and gauges are not obstructed.

Locate the 4001979-3 cable, and route this toward the back of the tractor. For most front wheel assist tractors this cable should reach to the plow harness that is installed on the tile plow.

Extension cables are available in 6, 12, and 24 ft lengths for 4-Wheel drive tractors.

---

## Plow Harness

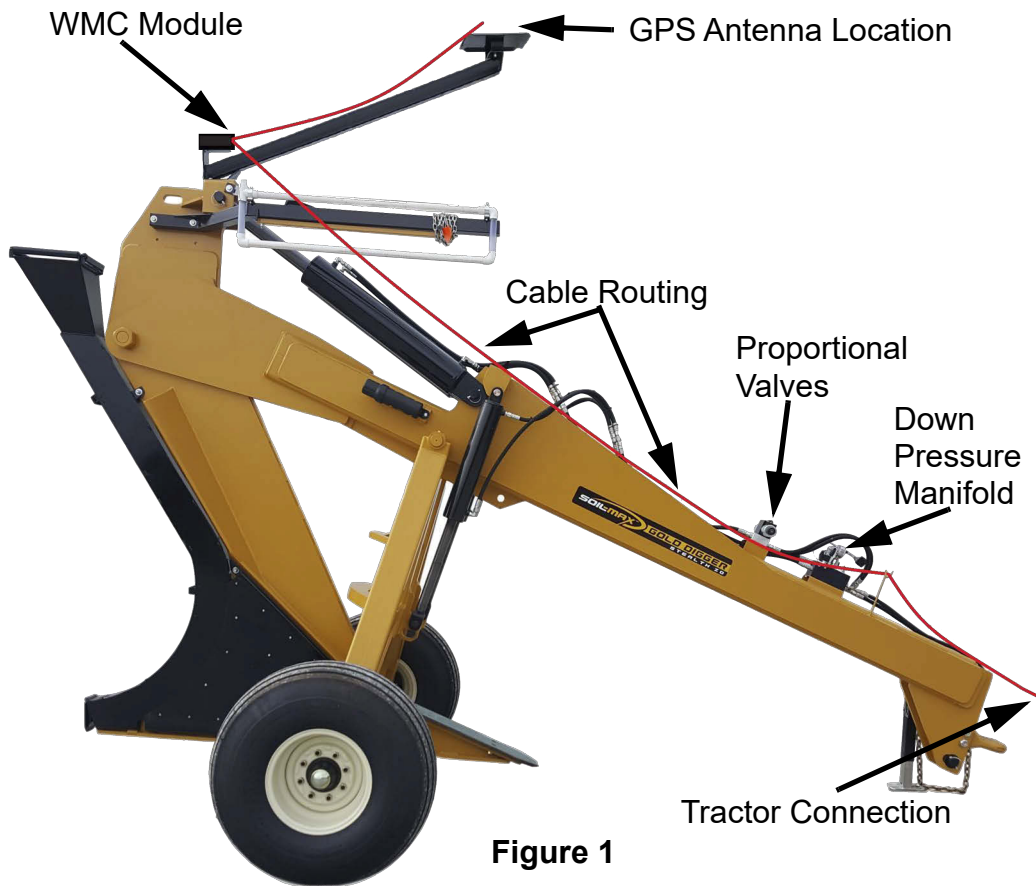

**Figure 1**

Locate cable PN 4003415. This will be mounted on the plow, with the single round cable connector at the hitch. There are 2 weather pack connectors that will connect to the proportional valve. Route the cable as shown below to ensure that moving parts do not pinch cables, extensions, or adapters.

# Intellislope® Tile PLOW Control System

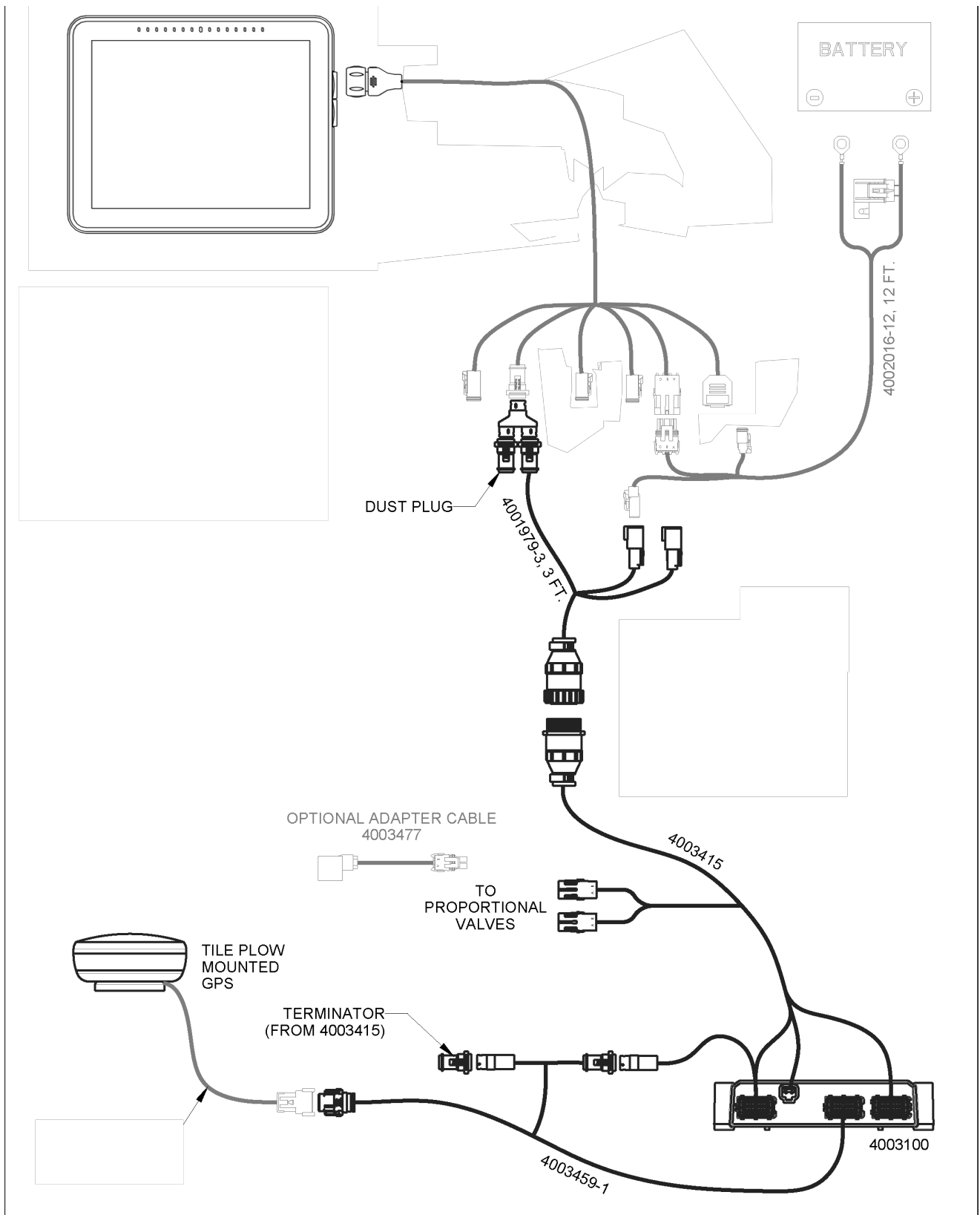

---

## Water Management Module



The module is designed to be oriented so the cable connections face the tractor. This is so the sensors are oriented correctly and work as designed. Use the provided module adapter plate and hardware to secure the module to the plow in the location as shown on the previous page. The label should also face up when installing. See below image.

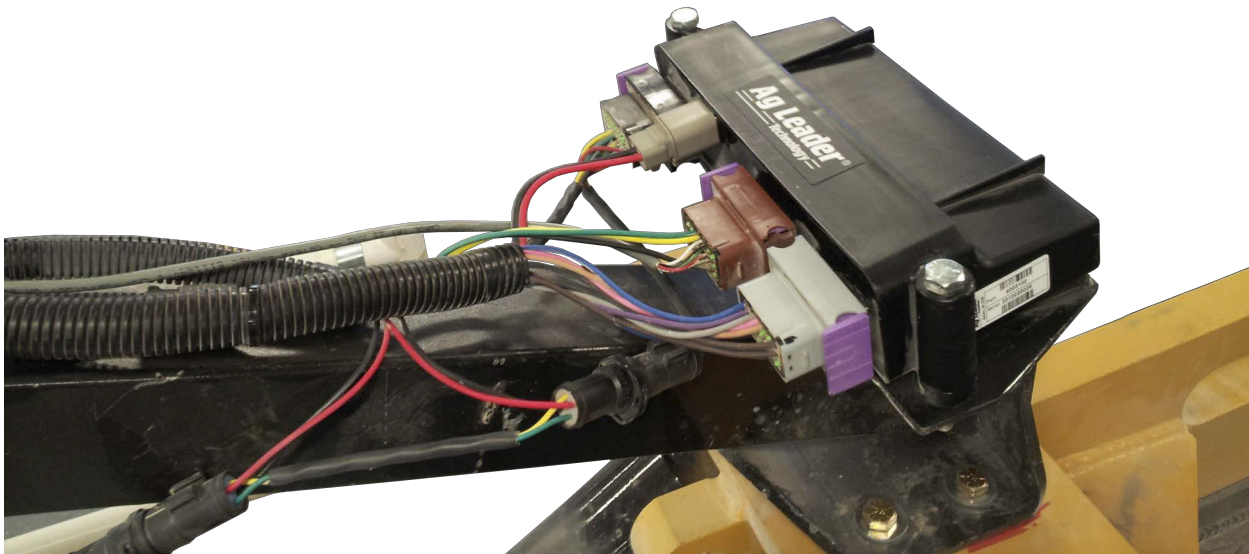

Make sure to color match the connections from the harness to the module and don't force the connections. This can prevent damage to electrical pins. The round connections on the harness are used to power the GPS receiver. The 3 large and 1 small square connections will connect to the module. The Brown connector will be used for the GPS signal input.

### LED (1) and (2)



- Off—CAN BUS is idle
- Flashing Green—CAN BUS communicating
- Blinking Yellow—Active BUS error when other devices are transmitting/receiving
- Solid Yellow—Passive BUS error when no other

devices are acknowledging

- Solid Red—BUS Off

## LED (Power)

- Off – no power
- Solid Red – Low voltage
- Solid Green – Good power

## GPS

Make sure the GPS receiver is mounted over the top of the cutting plane. There will be 2 cables that will connect the GPS receiver to the module, one is specific to the GPS receiver. The other cable connects to the WMC and has a standard connection for all GPS adapters.

Double check to make sure that all connections are made and snug, and all cables are secured and not routed in areas that will be pinched.

## GPS Receiver Configuration

For Intellislope® to receive GPS information from the receiver, the receiver needs to be sending out NMEA GGA, VTG, and GSA messages. NMEA is a standardized output that virtually every GPS receiver supports. When connecting non-Ag Leader receivers for use with Intellislope, the customer is responsible for knowing which port they are connecting to the WMC for NMEA output and configuring the output of that receiver.

For all receiver types, make sure that the following messages are turned on and that the receiver has an RTK fixed position.

- **Baud**—19200 or 38400
- **Hz**—5 or 10 Hz
- **NMEA messages**—GGA, VTG, and GSA. Turn off all other messages.
- **Terrain Compensation**—Receivers with built in terrain compensation must disable it, or plow performance issues may occur.

Some Ag Leader receivers connect through different ports. See below for specific models:

- **7500/6500**—Configure the above settings on Port B. Use GGA (Position). Verify StableLoc® and NMEA Talker are turned off.

- 
- **ParaDyme/GeoSteer/GPS2500**—Configure the above settings on Port A. ParaDyme and GeoSteer need to output GGA current. ParaDyme and GeoSteer antenna heights must be set to 0 in the steering vehicle profile.

## Create Configurations

### Configuration Wizard



OR



The wizard will then guide you through the process of creating a configuration. After finishing the wizard, the complete configuration should now appear on the Configuration Setup screen and is now able to be selected when starting a new field operation.

## Setup Tile Controller

### Configuration Setup

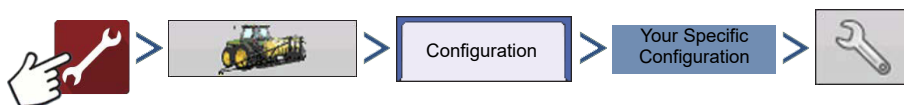

**i** **NOTE!** Use the Manage Equipment button to view a list of specific vehicles and implements.



## Implement Offsets

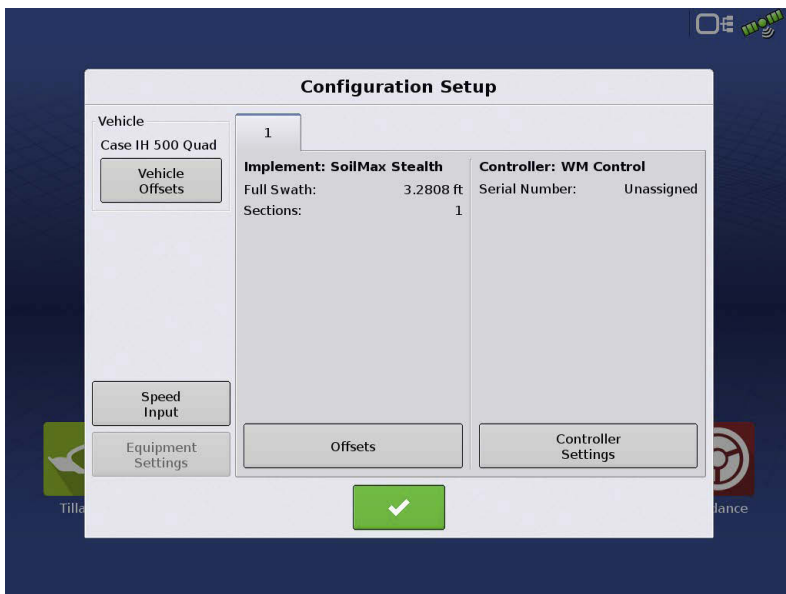

Vehicle Offsets

Press to adjust vehicle offsets.

Speed Input

Press to modify source of speed.

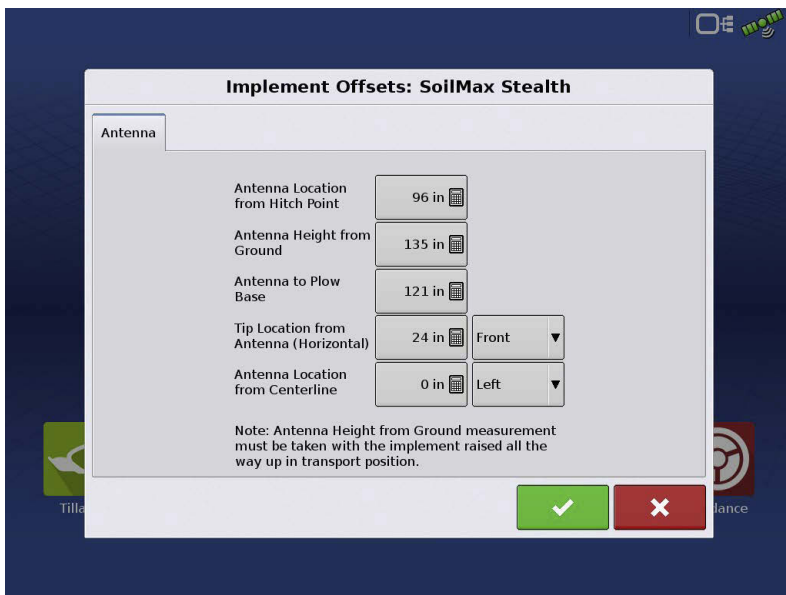

Press **Offsets** to adjust plow offsets that were setup when creating configuration.

**Tip:** Location from antenna (horizontal) is the horizontal measurement of the tip to the antenna. An example is if the tip is 24 inches front of the Antenna, you would enter 24 inches and front (as shown).

## Water Management

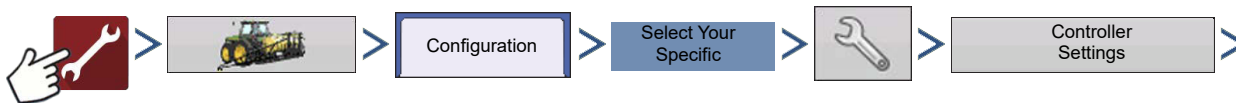

Configuration

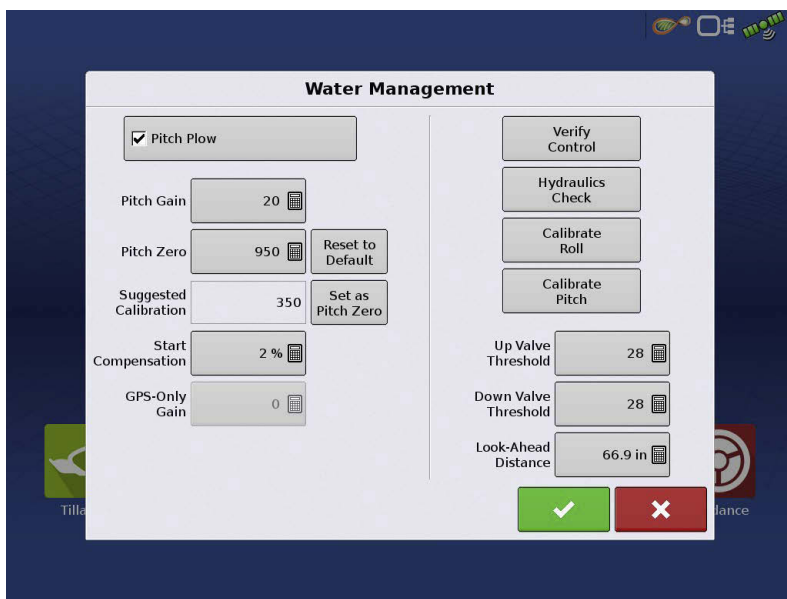

**Pitch Plow check box**—Check this box only if the machine is a pitch plow (also called cantilever).

If this box is not checked, Pitch Gain, Pitch Zero, Suggested Calibration, and Start Compensation boxes will be grayed out and unavailable.

This setting effects the operation of Intellislope and it is crucial that it is set correctly. When check box is checked, it indicates that the machine being

controlled is a pitch plow and the elevation of its cutting edge is determined by the pitch of the plow. This must be un-checked if the machine is not a pitch plow. Parallel link plows and trenchers are both non pitch plows because the elevation of the cutting edge of the maching is directly effected by the hydraulic cylinder displacement. In this case the GPS receiver must move with the cutting edge for proper control.

The following table summarizes the interaction between the pitch plow setting and adjustments on the “Performance Setup Screen”.

Adjustment	Pitch Plow Checked	Pitch Plow Un-checked	Comments
Pitch Gain	Yes	No effect	Pitch Gain only has effect when the system is controlling pitch, and thus only when configured as a pitch plow.
Look Ahead Distance	Yes	No effect	Look Ahead Distance only has effect when the system is using pitch to control elevation, and thus only has effect when configured as a pitch plow.
GPS-Only Gain	No effect	Yes	GPS-Only Gain only has effect when the system is directly controlling elevation in systems where the hydraulic cylinder directly controls elevation (not a pitch plow).
Pitch Zero	Yes	No Effect	Current calibration value to maintain grade
Start Compensation	Yes	No Effect	Setting to combat soil pressure at the start of a tile installation

**Pitch Gain**—Determines voltages necessary to effectively adjust pitch. It defaults to a value that works well for the Parker proportional valve and most hydraulic system flows and pressure. The gain may be increased for tractors with lower flow and pressure. Setting the gain too high will

cause the plow to respond in an unstable and erratic way. The higher the gain the more aggressive the valve responds.

**Pitch Zero**—Sensor reading that corresponds to level installation. Value will be set automatically after running Pitch Calibration. See [Ongoing Pitch Zero Adjustment on page 240](#).

**Reset to Default**—Resets Water Management Module to default. Settings may need to be re-entered and new calibration required.

**Suggested Calibration**—Every time a Grade Control or AutoTile® run is completed the system updates this number to indicate the pitch zero during that run. If your plow tends to run low, this number will likely be higher than the pitch zero, so increase the Pitch Zero to match this number if the On Grade indicator signifies the plow running low. Conversely if it runs high, then decrease the Pitch Zero to match this number. It is very important to watch this number to see if the Suggested Calibration number stays close (within 10) of the Pitch Zero. If it is more than 10 off either way, you should lower or raise the Pitch Zero to bring it to the Pitch Zero Suggested Calibration number.



**NOTE!** The suggested calibration and current pitch zero are viewable during operation under the diagnostics button for the Water Management module.

If for any reason the plow was operated in Grade Control or AutoTile mode with the plow out of the ground, then the Suggested Calibration number will be meaningless and should be ignored. Use the button beside the “Suggested Value” and set the Pitch Zero to the “Suggested Value” (the pitch number will be over written with suggested).

**Set as Pitch Zero**—Sets the Pitch zero to the number provided by the “Suggested Value”.

**Start Compensation**—At the start of an installation, the cutting edge of the plow tends to drop slightly as the shank contacts the soil. Start Compensation allows the operator to specify an initial upward pitch to offsets this drop. The extra pitch is reduced to zero over the first 2 meters after which it has no effect. Setting Start Compensation to zero is equivalent to turning it off. A typical setting is 2%.

**GPS-Only Gain**—This gain only applies when the Pitch Plow box is un-checked. It determines how aggressively the system reacts to elevation errors when controlling machines that are not pitch plows.

Value is normally set to 5 or less. Trial and error may be required for best results.

---

## Ongoing Pitch Zero Adjustment

The Pitch Zero may need to be manually adjusted from time to time so that it remains the setting for level installation.

The following may require it to be readjusted:

- Change in soil characteristics in which the plow operates, since soft or wet soil can cause the plow to “slip” relative to its pitch
- Substantial change in grade of the ground in which the plow operates
- Remounting of the module to the plow
- Change in ambient temperature.



**NOTE!** The best strategy is to let the On Grade indicator guide any adjustment. See [On-grade Indication on page 267](#).

## Plow Starting Numbers

<b>Soil-Max® Gold Digger Stealth ZD suggested Starting Values</b>	
Pitch Plow	Checked
Pitch Gain	20
Pitch Zero	900-950**
Start Compensation	2%
Up Valve Threshold	28
Down Valve Threshold	28
Look-Ahead Distance	66.9 in
Recommended Pressure	2950 PSI

<b>Soil-Max® Gold Digger 48 in. Plow suggested Starting Values</b>	
Pitch Plow	Checked
Pitch Gain	15
Pitch Zero	900-950**
Start Compensation	2%
Up Valve Threshold	28
Down Valve Threshold	28
Look-Ahead Distance	45 in.
Recommended Pressure	2950 PSI

\*\*This is an average range seen after calibration is completed.

## Rule of Adjustments

- If the plow is predominantly tracking below the target (too low), according to On Grade indicator, increase it.
- If the plow is predominantly tracking above the target (too high), according to On Grade indicator, decrease it.
- Otherwise leave it alone.

# Intellislope® Tile Plow Control System

Even when the Pitch Zero is well adjusted, the on-grade indicator may reflect deviations from on grade, which is normal and expected. The plow tends to round off sharp corners in the target profile. This will cause either high or low indications as it does so.

There is also a certain amount of deviation within a channel about the target profile that is typical as the control system hunts for the target and responds to external disturbances such as driving over rough terrain. The operator should remain aware of the on-grade indicator, and if grade error starts becoming abnormally large or erratic, he should look for any of number of pitfalls which can be giving rise to the problem.

Noise or error in the GPS elevation, noise in the pitch signal, rocks, soft spots, some degree of control system hunting and overshoot, among other things, can cause brief deviations from on grade. Only when the plow is consistently high or low does the Pitch Zero need adjustment.

## If any of the following occur, the Suggested Calibration should be ignored:

- Operating in the “Installing” state while the plow is out of the ground.
- Operating in the “Installing” state, while any external force is being applied to the shank, including any of the following:
  - Lifting or lowering using the three-point hitch or wheel frame
  - Not placing the three-point hitch or wheel frame into float during installation
  - Exerting force on the shank by manually extending or retracting a hydraulic cylinder such as the diagonal lift cylinder on a Parallel link plow
  - Operating a Soil-Max pull-type plow too shallow such that the wheel cylinder forces have too large a component in the vertical direction.
- Operating in the “Installing” state when GPS, GPS quality or GPS RTK correction is lost.
- Installing a tile run in Pre-Ripped ground
- Operating in the “Installing” state when the three-point hitch, wheel frame, or raise/lower diagonal cylinder on a parallel link plow is not fully in float.

If any is known to occur, the Suggested Calibration number should be ignored until after the next run.

## Verify Control

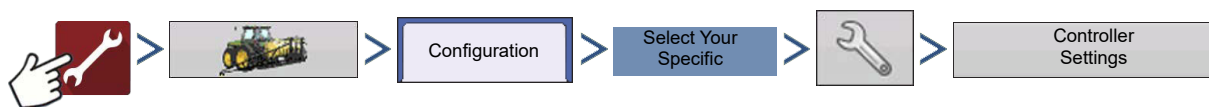

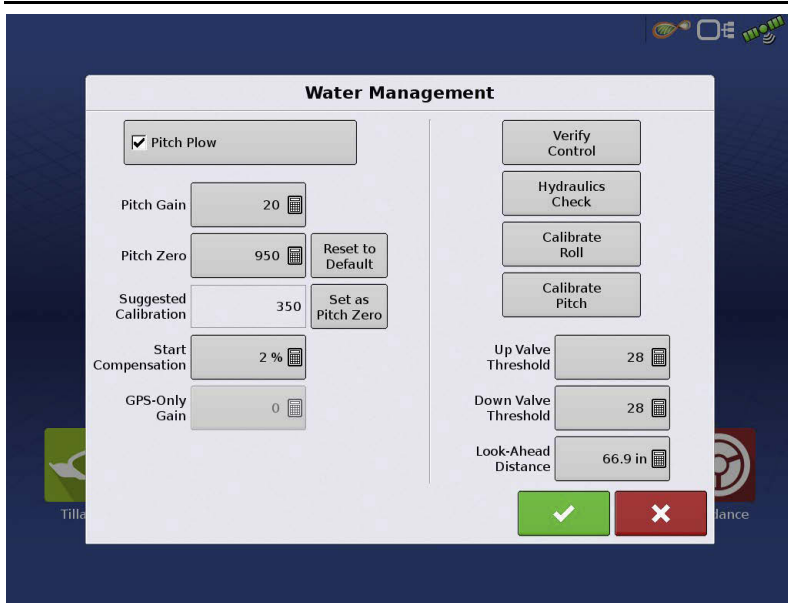

Verify Control will check to make sure hydraulics are functioning correctly and determine the voltage necessary to move the cylinders.

**NOTE!** This may require that you move over a trench to allow the plow shank to move freely, and not overturn or interfere with the ground.

Adjust the Up/Down Valve Thresholds, and then go to the Verify

control screen and use the Up/Down arrows. Adjust the up/down threshold values until moving the arrows makes the implement start to respond.

To run the Control Verification, press button and follow instructions on the display.

If the implement responds opposite of the commands (for example if the UP button makes the plow go down). Verify correct hydraulic flow direction and hydraulic hose connections. If hydraulics are correct, switch proportional connectors or valve polarity.

**Up Valve Threshold, Down Valve Threshold**—These two settings control how much voltage needs to be applied to the valve to cause the cylinder to begin to move. The higher the number, the higher the voltage the system will apply to begin moving the cylinder, and the quicker the response. The lower the value, the more slowly it will move. On the previous screen, use the up and down buttons to see if those values improve response.

## Hydraulic Pressure and Hose Hookup

It is critical to have hydraulic pressure when operating the plow. Take care that the hydraulic flow is in the correct direction. On the front of the Soil-Max hydraulic valve near the hydraulic lines you will see a P and T which stand for pressure and tank. The hose that has the pressure on it is the hose that goes into P or the pressure side of the valve. You can normally tell the pressure side by the stiffness and vibration feeling in the hose.

The tractor's accessory oil pressure should be set high and in the detent position. Pitch plows encounter large forces which must be overcome by the cylinders. High hydraulic oil pressure is

required to generate these large forces. Setting the oil pressure too low will cause pitch control errors.

When using a Soil-Max Gold Digger tile plow, the minimum recommended pressure setting is 2,600 pounds per square inch and the minimum recommended flow setting is 10 gallons per minute.

If the cylinders neither retract nor extend then one of the following may be the cause:

**Problem**—No hydraulic pressure is available.

**Solution**—Tractor must be running, hydraulic detent engaged and hydraulics must be connected to proportional valve.

**Solution**—Hoses may be reversed or you may have a bad hose connection.

**Problem**—Harness is not securely connected to both module and hydraulic valve.

**Solution**—Check that module-side plug is completely inserted and the connector is locked.

**Solution**—Check that the valve solenoid connectors are fully seated and screwed down.

## Hydraulics Check

This is an automated exercise that only applies to implements configured as 'Pitch Plows' that will extend and retract the pitch cylinders in order to correctly set the valve polarity.

This requires that you detent your hydraulics and may require that you move over a trench to allow the plow to move freely, and not overturn or interfere with the ground (suggested to do this away from concrete). Several items are checked during this exercise:

- Module is connected properly
- Cables are secured to the proportional valve correctly.
- Hydraulic flow is set high enough
- Solenoid connections are secured for operation

# Roll Calibration

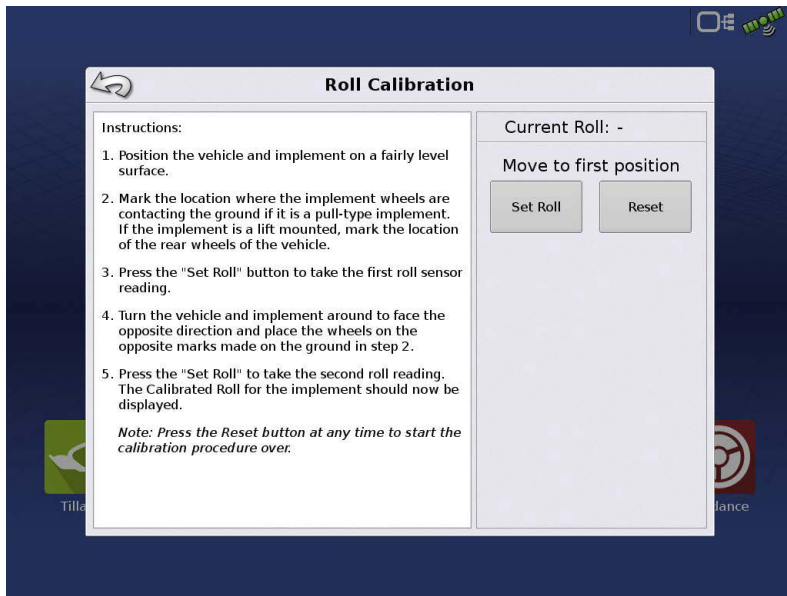

1. Position the vehicle and implement on a level surface.

2. Mark the location where the implement wheels are contacting the ground if it is a pull-type implement. If the implement is a lift mounted, mark the location of the rear wheel of the vehicle.

3. Press the "Set Roll" button to take the first roll sensor reading.

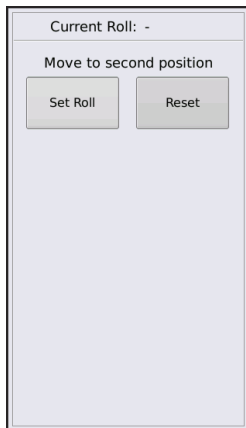

4. Turn the vehicle and implement around to face the opposite direction and place the same wheels on the marks made on the ground in step 2.



5. Press the "Set Roll" to take the second roll reading.

The Calibrated Roll for the implement should now be displayed.

 **NOTE!** Press the Reset button at any time to start the calibration procedure over.



## Pitch Calibration

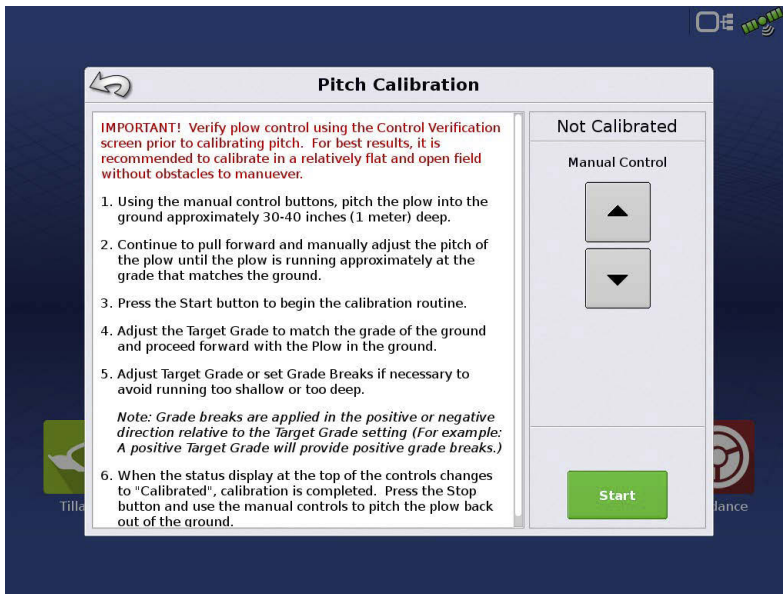

Pitch calibration number determines sensor reading for level installation. Plow status will read "Not Calibrated" until Pitch calibration is ran. Only after having followed those instructions will you need to adjust this pitch zero number.

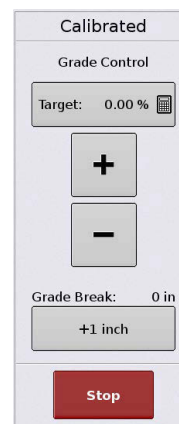

After this initial calibration run, the Pitch Zero will be set automatically. From then on, any changes to the Pitch Zero need to be made manually.

To run Pitch Calibration, Press Pitch Calibration button and follow instructions given on the display. When running a pitch calibration, it can take up to 600 ft of level or constant grade ground to complete.

## Look-Ahead Distance

This normally does not need to be adjusted on Gold Digger plows following the default value chart. On other plows, start by setting the horizontal distance (in inches) from the tile boot to the shear of the plow. If performance is not optimal, longer distance will smooth out the plow and make it less reactive. A shorter distance will make the plow react quicker but may cause oscillatory "hunting" about the target elevation.



**NOTE!:** Default valve 66.9 in. for Gold Digger Stealth ZD plows and 45 in. for ZD48 in. plows.

## Antenna Offsets

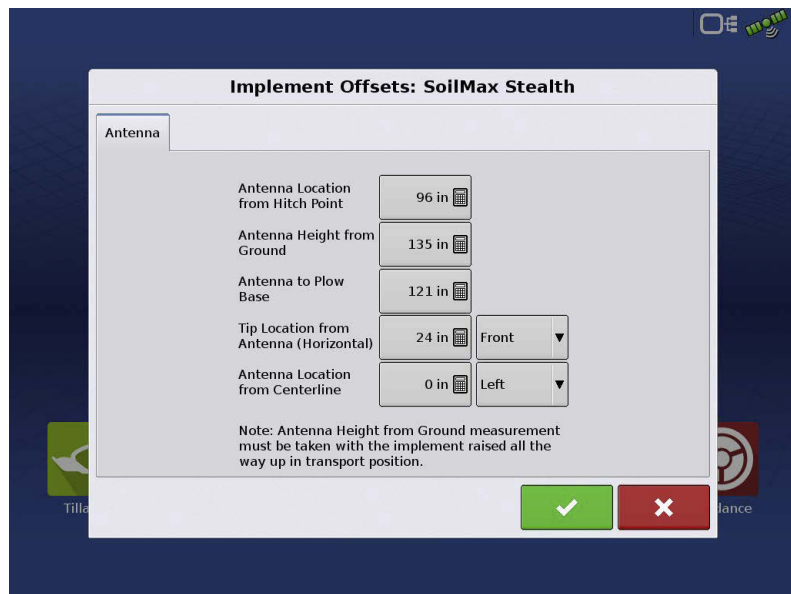
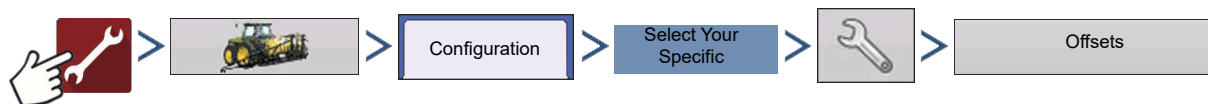

### Antenna to Plow Base

Measure the vertical distance straight down from the GPS antenna to the very bottom of the plow (bottom of the skid plate). AutoTile uses this distance to compute the tile trench elevation from the GPS antenna's elevation. Distance affects the depth because it affects how far the plow shear is below the antenna as it is lowered.

### Antenna to Tip (Horizontal)—This is

the distance from the Antenna to the tip of the plow or cutting edge. If you had a rope hanging straight down from the antenna, it would be the horizontal measurement from the tip to the rope. If the tip was 24 inches in front of the antenna, you would enter 24 in front.

**Antenna To Ground**—This measurement tells AutoTile how high the GPS antenna is above the ground when surveying. Measure from antenna, straight down to ground when plow is in surveying position. Plow must be completely lifted and plow boot is pitched all the way up.

## Topography

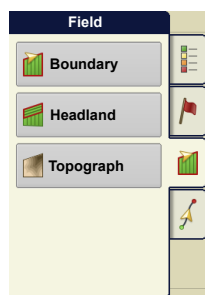

From the mapping screen, press “Topography” button to enter the Topography screen which allows user to setup Topography functionality.

The display allows you to record points that can be used to make a reference layer that is relative to the elevation throughout the field. This can provide you with valuable information in regards to the highs and lows of a field when you may not be able to visually tell with the naked eye. Surveying and Tiling operations will probably benefit the most with respect of where to place the mains and laterals in a field.



**ATTENTION!:** Requires RTK GPS signal to collect the accurate elevation data.

You can also import data from mapping software such as SMS™ Advanced via .agsetup files.

## Topography screen

You are allowed to have multiple topographical elevation surveys for the same field. This can be useful for different applications, for example:

- One topographical survey that is for the entire field. This will give you a greater perspective of the whole field.
- An additional topographical survey, driven at very dedicated portion of the field. This would allow you to have greater elevation detail in certain areas if you need it.

By default the naming that is generated in the display will be Date/Time based. You can export surface elevation data from software packages like SMS Advanced into the display, and those will be tagged with the field name and the date exported (both examples are in the screen shot).

You can also add points to existing topographical surveys and save them.

Only one topographical survey can be active at a time. When exported as an .agsetup or .agdata file, this will be the survey that is exported. Non-active surveys will stay in the display. At any time you can remove an topographical survey, and collect a new one.

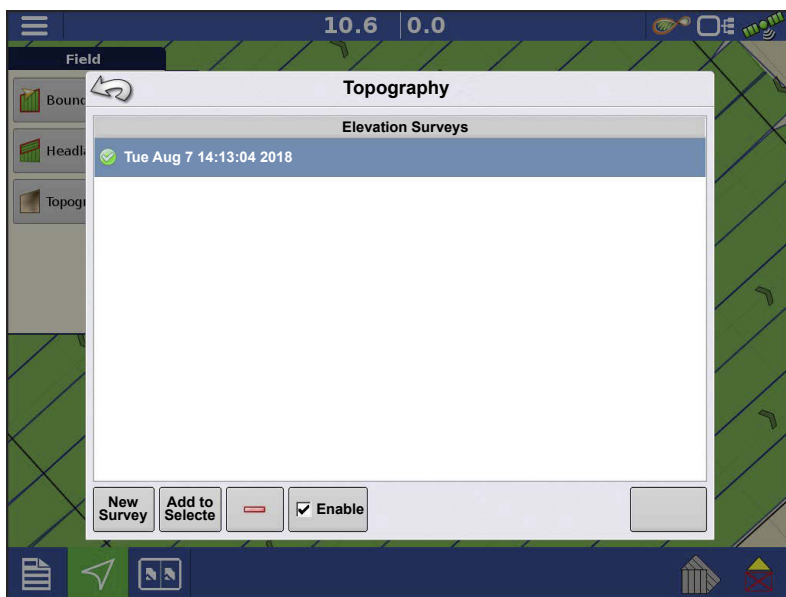

•New Survey button

Press to create a new topographical survey

•Add to Selected button

Press to add to an topographical survey

•Minus (-) button

Press to delete a topographical survey

•Enable checkbox

Press to turn topographical reference layer on/off (Enable checkbox functions the same as Topography checkbox in Map Options screen - shown below.)

---

- Set Active

Select the desired topographical survey from list and use button to set as active.

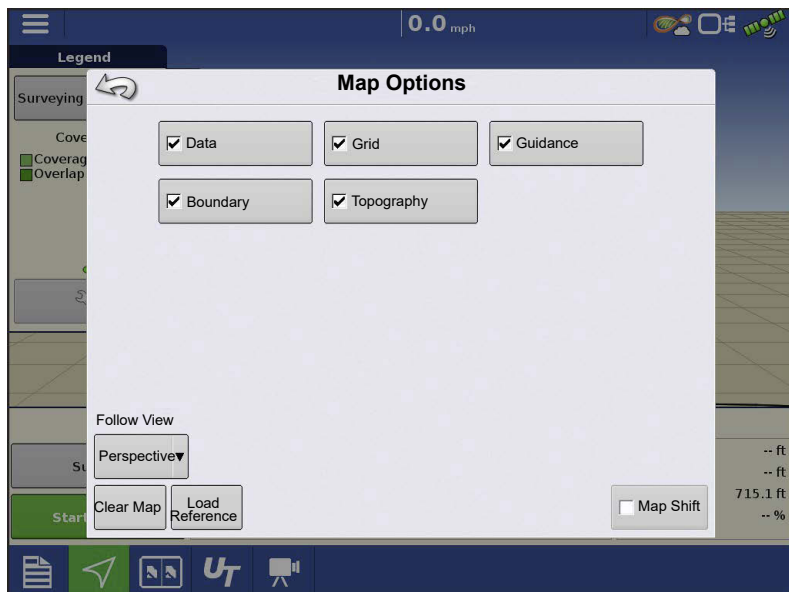

The topography layer can be turned on/off as a reference layer during any operation using:

- Enable checkbox on Topography screen (shown above).
- Using the Topography checkbox on the Map Options screen.



If you have RTK GPS reception, you are allowed to collect an elevation survey. This will allow you to collect the Latitude/Longitude and elevation values as you traverse the field.

A point will be dropped every 10 ft as you drive regardless of speed, or direction. If you are collecting during operations like planting or application using AutoSwath™, it will also log points outside the boundary of the field

(i.e. through a grassed waterway) to get the most information throughout the field.

During collection of an elevation survey, points will be logged to the file every 10 ft. An on-screen visual will appear in the form of a single black dot (**A**) every 100 ft.



**ATTENTION!:** It is critical that the GPS Antenna to ground measurement is correct in your configuration, any error in this measurement, will add to the error in the data logged.

# Intellislope® Tile Plow Control System

The following are suggestions to get the best possible elevation survey for a given field.

Following these recommendations will provide the best results for your field.

- Keep swaths in the field to 62 ft or less, the closer the better.
- Driving a dedicated route at the lowest or highest points in a field (i.e. lengthwise of a grassed waterway, or at the top of a ridge) then traversing the field in regular swaths will provide the best detail of the field.
- If surveying with the tile plow antenna, ensure that the plow is in the fully raised position.
- Driving too fast with mounted plows, can cause bouncing and affect quality.
- Surveying with harvesting equipment can provide streaked maps as the hopper filling and unloading can affect the height of the vehicle, and therefore antenna.

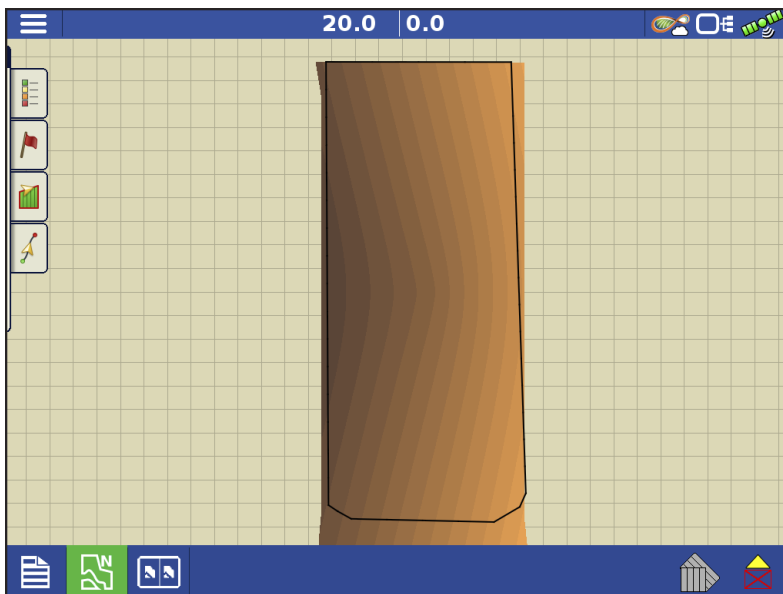

After the survey points have been collected, they will be converted into a surface layer in which you can define the color scheme Red, White, Blue, or Brown-Tan.

You can select the number of legend ranges for your field that will show the areas desired. This theme will be used for each field until changed.

Hues will represent:

**Red, white, blue scheme**

Darker blue = Lower elevation.

Darker red = Higher elevations.

White will be a transition color between.

## **Brown-Tan scheme**

Dark brown = Lower elevations.

Tan = Higher elevations.

If at any point during collection your GPS correction status changes out of RTK fixed, logging will be suspended.

---

If you re-acquire the RTK signal, logging will automatically resume.

At any point you can  (pause) or  (stop) collection of the elevation survey, and then  (resume) as needed.

If you forget to stop logging as you leave the field, you will be prompted with the message that data collection is still active, and be given the option to continue logging, or end operation.

In Odd-shaped fields, the surface rendering of the elevation will connect areas even if you haven't driven through that area.

## Survey

### About Surveying

AutoTile can make tiling much easier by creating a sophisticated target profile that hugs the topography of the ground at a selected depth. AutoTile requires that a survey is taken, which records the soil elevation profile, before installing tile. The profile is created by driving over the path where the tile will be installed with the Intellislope system in Surveying Mode. The profile is used to create the target profile for tile installation.

### Surveying With a Vehicle (Not With Plow)

Surveys may be conducted prior to installation. This allows the flexibility of performing surveys with other vehicles such as ATVs, trucks or utility tractors. The survey log can be saved on a USB drive and transferred to a different vehicle or display for installation. Ensure that the GPS antenna is securely mounted, and that the Antenna Distance To Ground entered in the Machine Setup screen is correct. Survey logs record the elevation of the ground based on this setting. The log will reflect the setting at the time the survey was made. Any change to the Antenna Distance To Ground setting will not take effect until the next survey is performed.

It is also strongly recommended that if doing a survey days prior to installation that the GPS Base station is not moved, or is reset in exactly the same location as when the survey was collected. Failure to have the base in the same location can render the surveys inaccurate, requiring them to be redone.



Press the Water Management App to begin the field operation wizard. Be sure to choose the correct surveying configuration.

# Intellislope® Tile Plow Control System

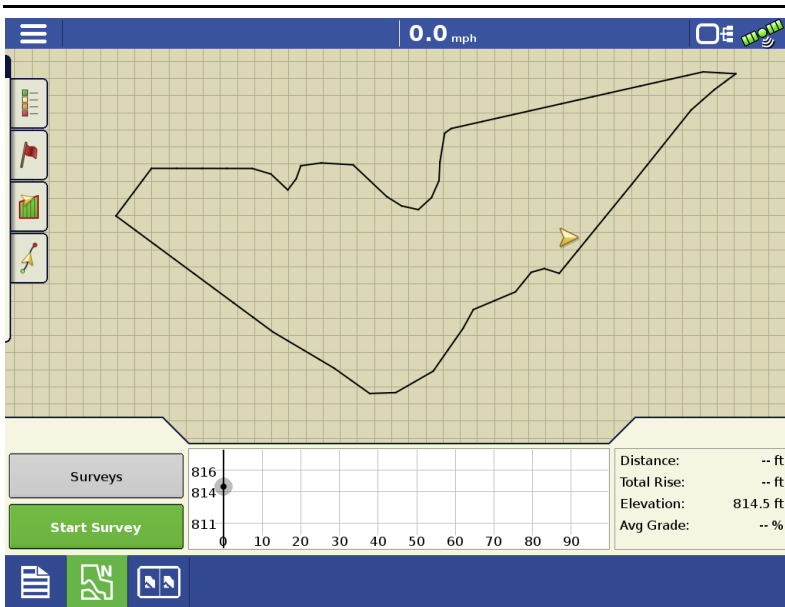

Drive to the location where you want to start the survey and press

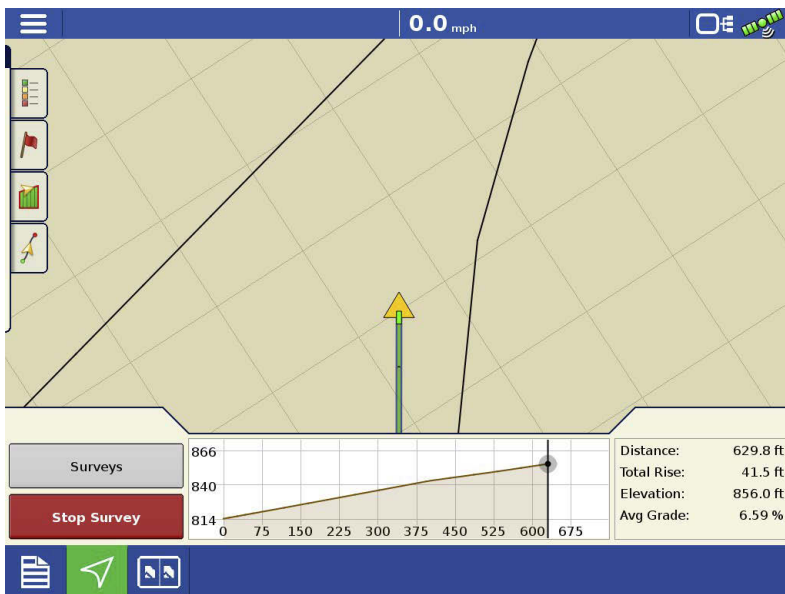

Drive the path where tile will be placed. At the end of the path press:



Confirmation Screen will appear.

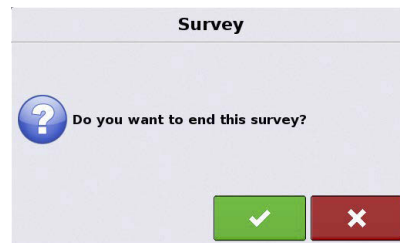

Press  to end survey.

## Surveying with Plow

When surveying with the installation tractor and plow, the plow must be completely raised so the GPS antenna distance to ground is consistent for every run and matches the Antenna Distance To Ground entered in the display.

For pull type plows, make sure the wheels are all the way down, and the plow shank is pitched up. For mounted, or 3pt mounted plows make sure the linkage is all the way up, and the plow shank is all the way up.

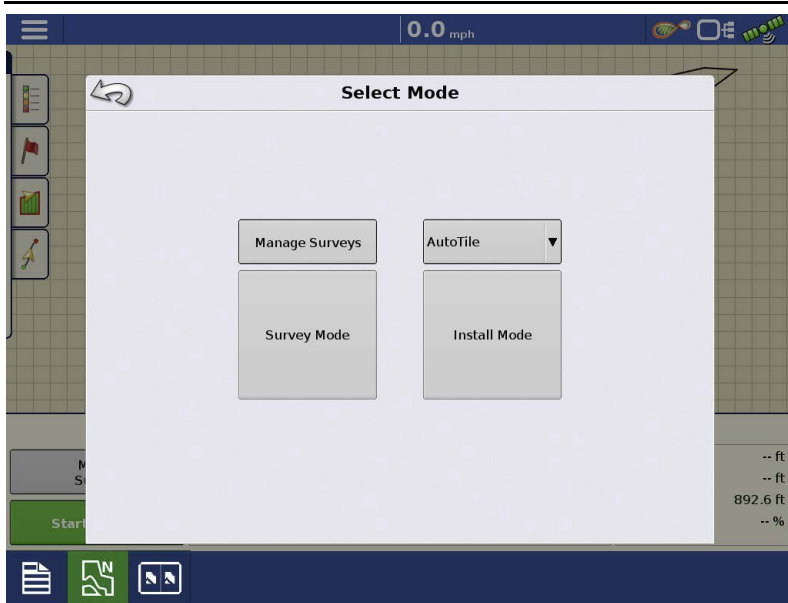

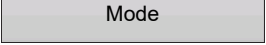
Press  to view Select Mode Screen.

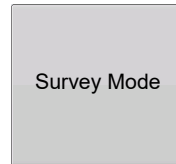

Select Survey mode.

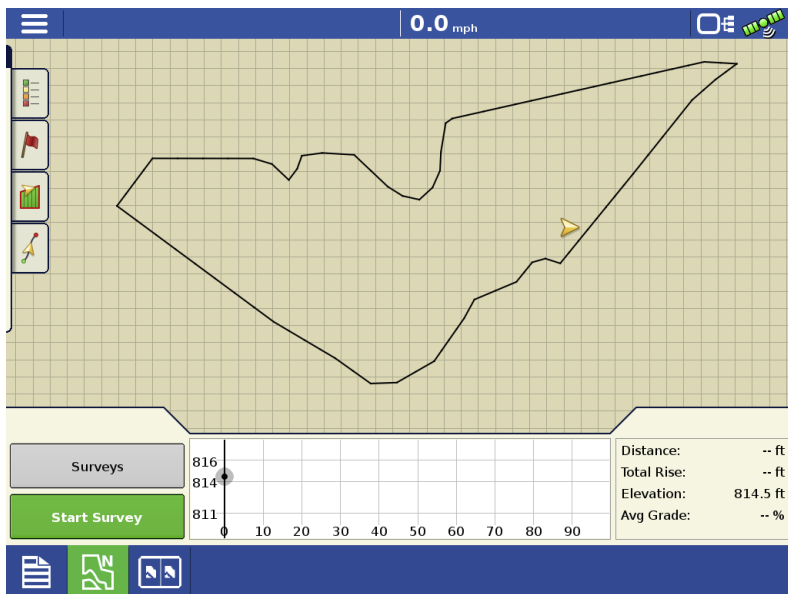

Drive to the location where you want to start the survey and press:



“Start Survey” will change to “Stop”.

As you drive, your path will be indicated with a green line.

Try to get as close to the outlet or main connection as possible (whether at the

start of the survey, or the end of the survey, doesn't matter), before ending the survey, but do not back up or make a loop around the starting hole while you are still surveying. Drive past the start of installation and near it if possible.



# Intellislope® Tile Plow Control System

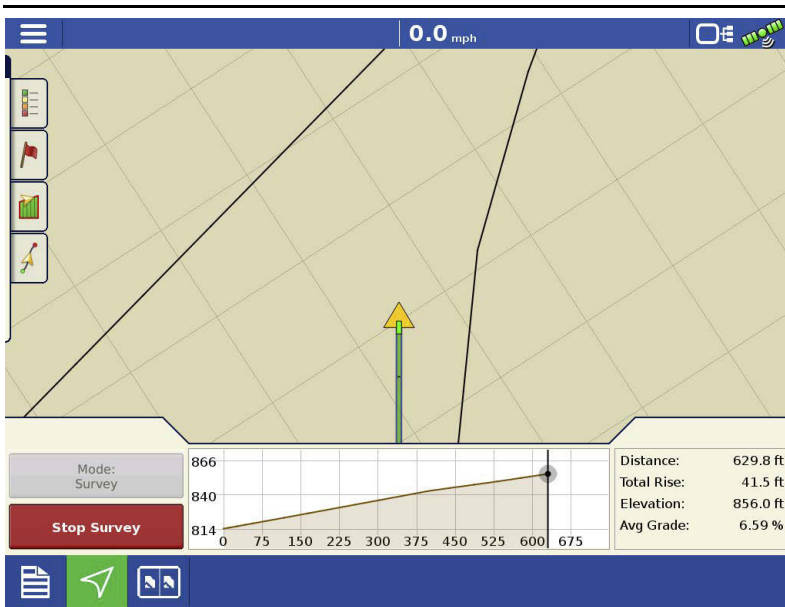

Drive the path where tile will be placed. At the end of the path press:



Confirmation Screen will appear.

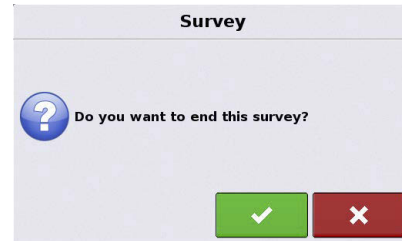

Press  to end survey.

## Managing Surveys

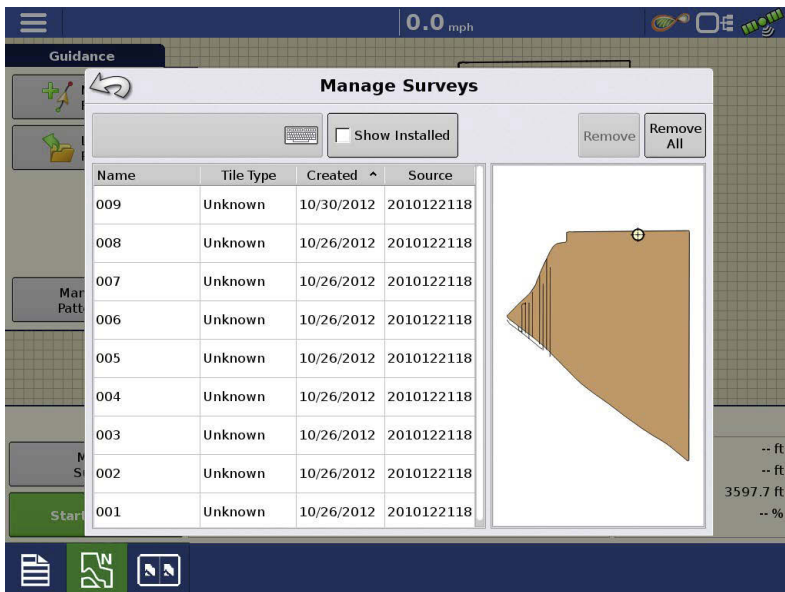

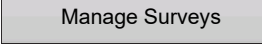
Press  to view Manage Surveys Screen.

Survey paths are automatically named but the names can be changed by choosing a survey and pressing





. Type a name then press



to enter it.

By checking  Show Installed, you will display the installed tile.

An individual survey path can be removed individually using the  button or all survey paths can be removed using the  button.

## Operating Modes

**AutoTile**—Driving over the tile's path to survey it and then display creates optimal tile placement according to guidelines set by user.

---

**Grade Control**—Behaves like a laser control system, except that the grade can be changed without relocating or adjusting a laser tripod, and grade breaks are not limited by mast size.

**Pitch Control**—Fall-back mode for when GPS is temporarily unavailable. (Only available on configuration set to “Pitch Plows”)

Each of these modes of operation are described in detail in its own subsection of this section.



**WARNING!:** Hydraulic machinery can cause bodily injury or death!

The Intellislope control system is designed and tested with safety of operation in mind, however, the operators should never assume that they can anticipate the behavior of the system while it is powered. Follow these rules:

Stay away from the controlled machinery. Always ensure that no person is within the range of motion of the controlled machinery while the control system is powered.

If it should be necessary to work in proximity to the machinery, first power off the control system. The system may be powered off using the display or by removing the system harness.

When controlling machinery other than a Gold Digger plow, the operator must exercise good judgment to ensure that the range of motion of controlled machinery is clear while the system is powered.

Turning off the display, or cutting the power by removing the accessory power plug, will remove power from the hydraulic valve solenoids. This will cause the Parker proportional valve, which is standard on the Gold Digger tile plows, to close.

Other components of the machinery, such as hydraulic system elements, have their own safety rules which are outside the scope of this manual, but which you should familiarize yourself with and follow.

## Installing with AutoTile®

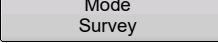

Press the  button on the map screen and then on the Select

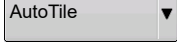
Mode screen, select 

and press the .

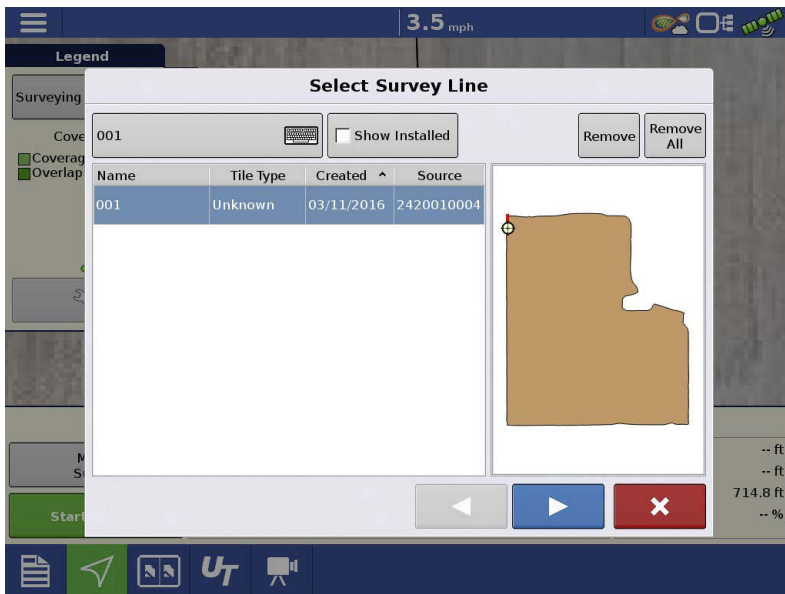

Selecting

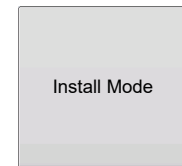

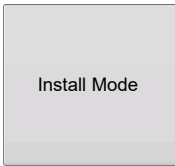
 brings up the survey selection screen. The selected survey will be drawn as a red line on the over-head map shown on the right side of the screen. If a survey has just been completed, it will be selected by default.

Select the desired survey and press  to continue.

## Modify AutoTile Design

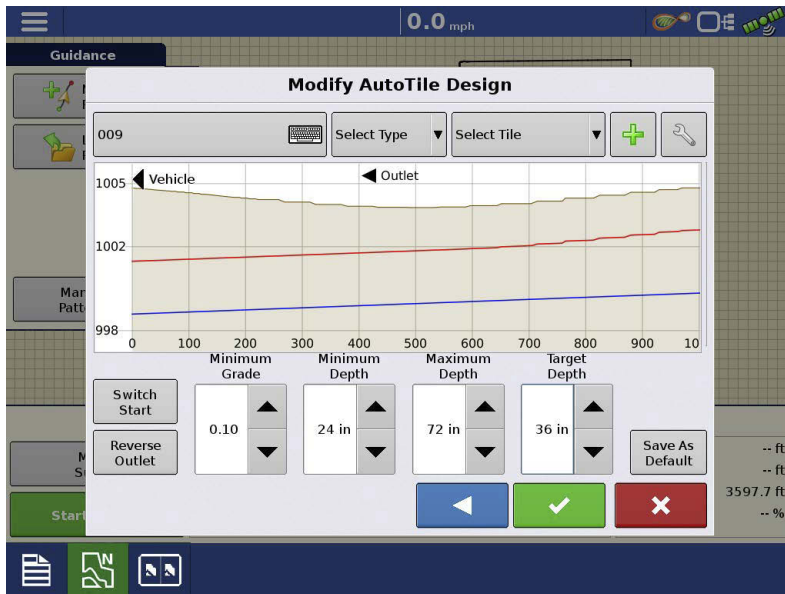

**Minimum Grade**—This is used by AutoTile to create target tile profiles. It specifies the minimum grade you wish AutoTile to maintain. 0.1% grade is a common minimum grade. Min Grade affects the target profile that the control system “aims” at. It is normal for some deviation about the target within a channel about the target profile.

**Minimum Depth**—This specifies the shallowest depth at which you want AutoTile to place tile, at any point in the tile run. Keep in mind that this depth is to the bottom of the trench. You might want to change this distance if you change to a pipe with a larger or smaller diameter.

**Maximum Depth**—This is used by AutoTile to know how deep the plow can go. You can either use the maximum depth of the plow or use this to limit the depth you wish the plow to run to lower the pull required if ground conditions are difficult.

**Target Depth**—This is the depth at which AutoTile aims to install the tile (as long as other constraints permit). This is usually in the 30-42 inch range. You should adjust this if necessary to keep your tile above impermeable clays. This depth is to the bottom of the trench.

## Switch Start Button

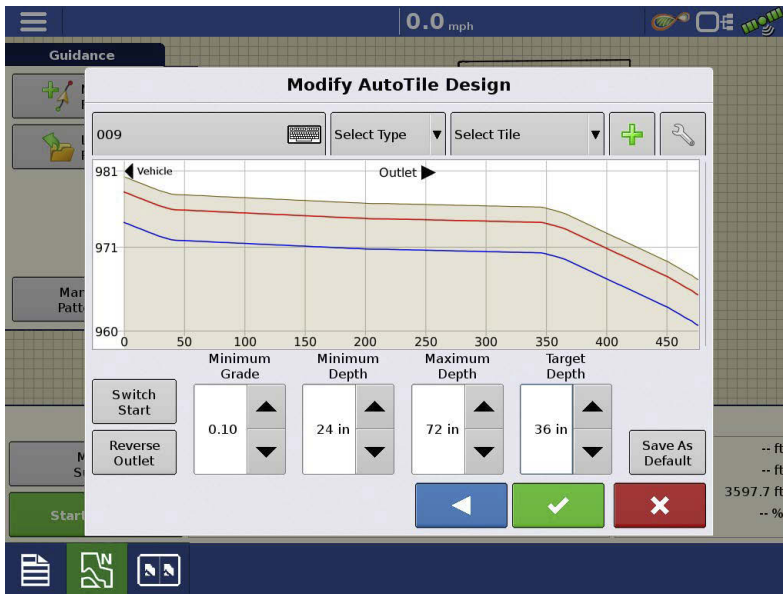

(Start at Top or Bottom of Run)

On the graph display screen, installation always proceeds from left to right. AutoTile assumes you will start at the lower end of the survey, and that the lower end is the outlet of the tile.

If Intellislope shows your vehicle location at the right side of the screen when you want to start installing, press “Switch Start”.



The “Switch Start” button switches the starting and ending locations. The ground's profile will be flipped, and your current position will now appear on the left side of the screen.

# Reverse Outlet Command

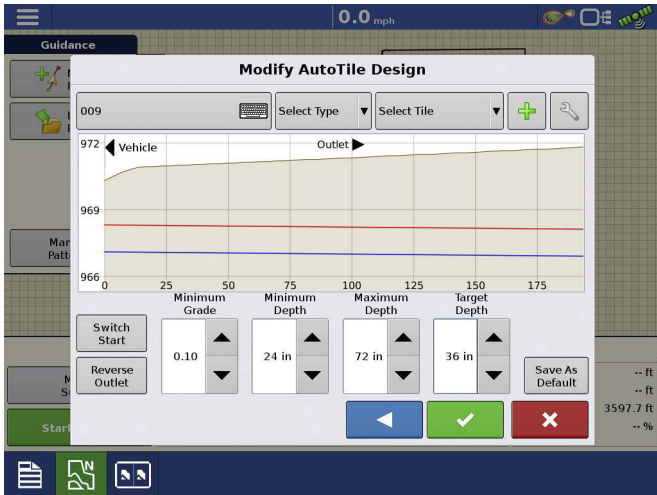

The “Reverse Outlet” button changes which end the outlet is on. The outlet end is the end of the path towards which the water drains. There is no effect on the ground profile, which remains unchanged.

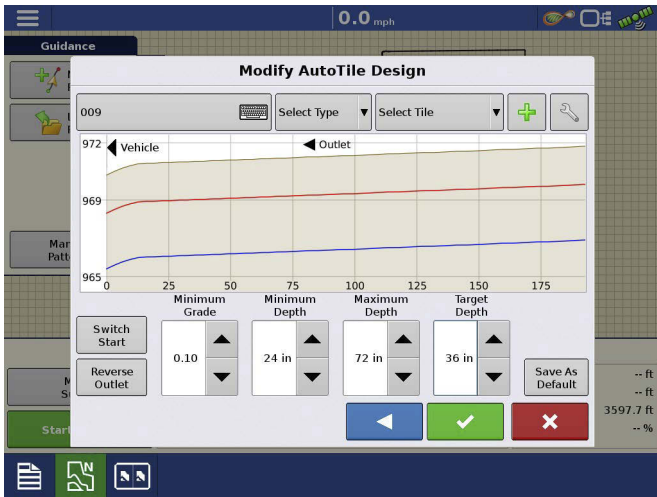

The difference appears in the shallowest and deepest installation profiles, which now are designed to drain in the opposite direction.

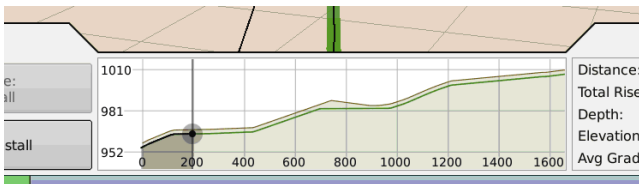

As you start installing, you should always progress from the left side of the profile graph to the right side. If your vehicle position indicator is at the right side, press on the profile graph and

modify your outlet location and/or your starting location.

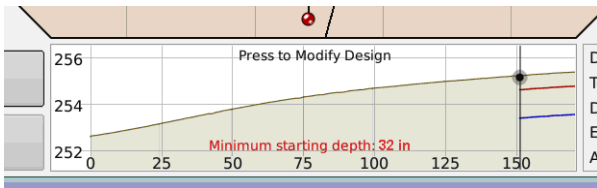

You are allowed to start installation at any point along the surveyed path. If the profile graph is as shown on the left, and you start installation, the tile will be placed at a 0.0 grade

## Adjusting Profile to allow Tiling

When a solution exists (which depends on the topography and the constraints you have specified)  will be displayed.

The profiles displayed will enforce the “Minimum Grade”, “Minimum Depth” and “Maximum Depth” constraints that you select. The display will create a target profile that maintains Target Depth as much as possible. As you adjust these parameters, the profile will update.

This can be useful in a number of ways. For example, to make the plow easier to pull, you might wish to decrease the “Maximum Depth” constraint as much as possible.



It is possible that no solution exists given the topography and constraints. Here, the system displays the message “2 in of interference at 742 ft” Given the topography and user constraints there is no profile that can be installed that meets all these constraints.



Increase the “Maximum Depth” to 75 in. to create a solution. The shallowest solution requires us to start at least 2.2' deep. Start at this depth or any depth greater.

Press  to accept target profile.

## Tile Type

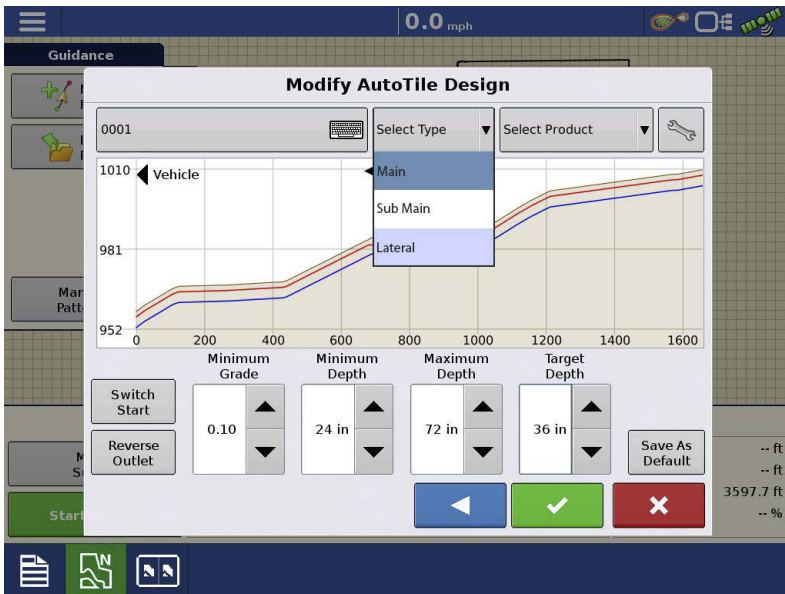

Select Tile Type from drop-down menu.

- Main
- Sub Main
- Lateral

## Select Tile Product

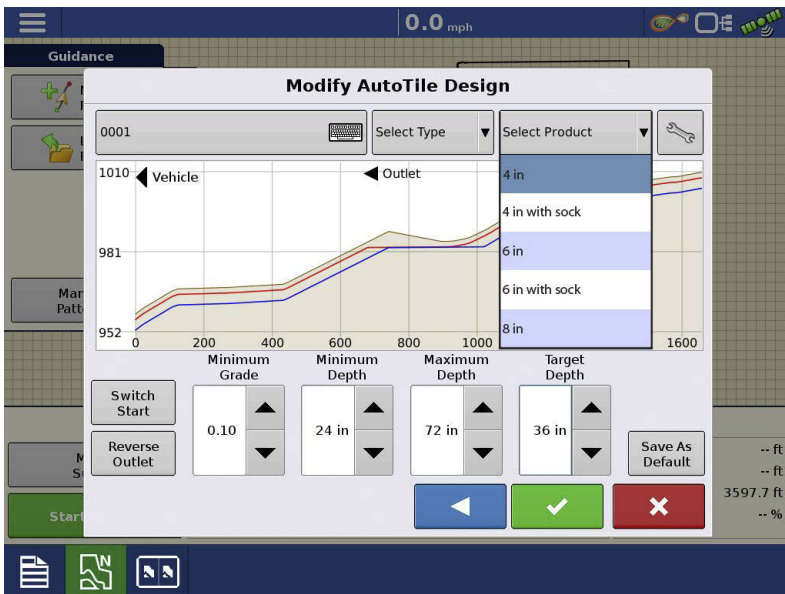

Select Product from drop-down menu or create a new product by pressing



and using the following steps.



## Creating Tile Products

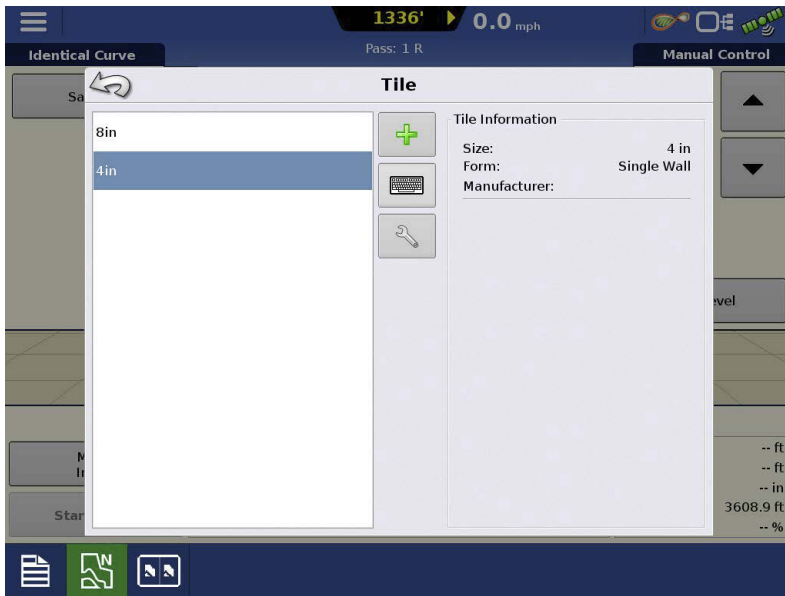

Press  on the AutoTile Design screen and then press .



Enter a name, tile size, form, manufacturer. Any notes can be added in the memo section.

Press  when complete.

## Start Depth Message

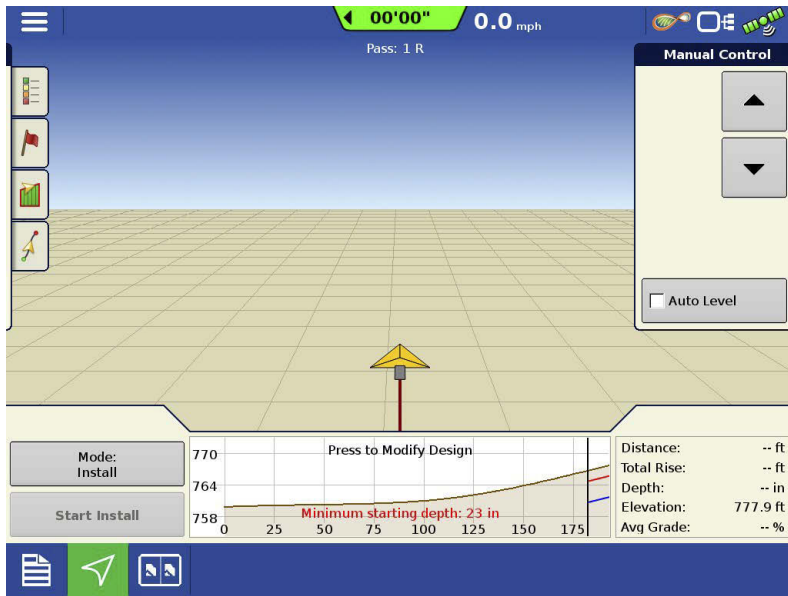

The plow may be lowered to any depth at or below the minimum starting depth, when installing from the outlet end, or uphill, as in most cases. Here the plow is still above the starting depth and a warning message, “Minimum starting depth: 23 in.” is given.

If your starting point for the install is in a location that is in front of your survey, the “Start Depth message”

may be too shallow as it is reported based on the first point of the survey. For example - if the start depth is 34" but you are 30 ft away from the beginning of the survey, you may have to lower to 35" to maintain your grade from the start of install to the start of the survey.

You must be within 65 ft (20 m) of the start of the survey to be allowed to start installation.

Start Install button will be grayed out until plow has been lower to proper depth.

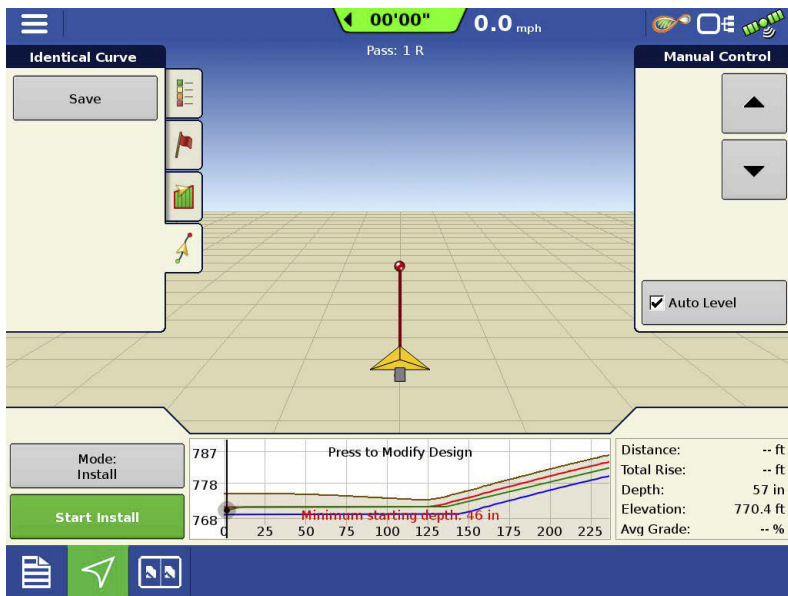

**Auto Level**—Automatically levels the cutting edge of the plow as it is lowered to its starting position (pitch plow).

If the machine is not configured as a pitch plow, the “Up” and “Down” buttons are used to manually adjust the position of the machine's cutting edge.

Note that the plow depth indicated on the screen is relative to the elevation of the nearest surveyed point, which is not necessarily the same as the depth in the hole, since the surveyed path may have ended some distance from the starting hole.



**WARNING!** When the plow has been set into the hole, press the “Start Install” button to be ready to start installing.

When pushing AutoLevel make sure people are clear, as the machine will move.

## AutoTile in Process

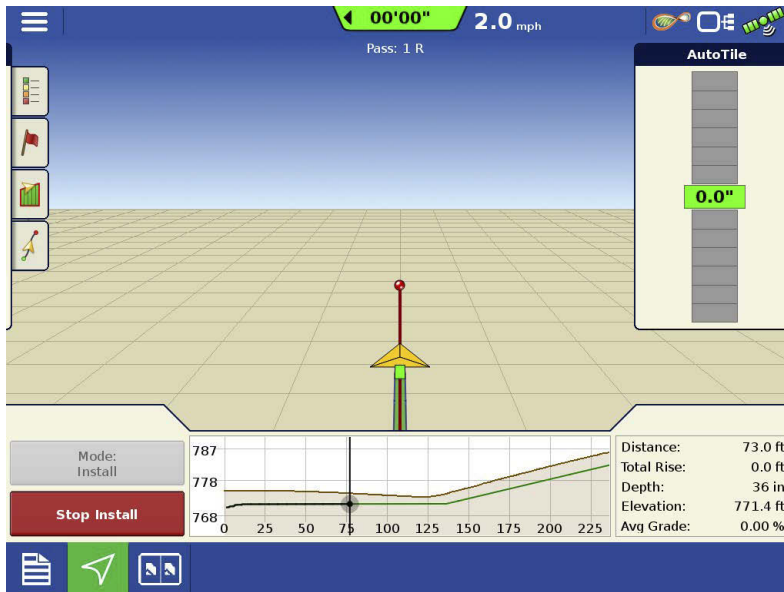

As installation progresses, the progress is marked by a shaded region under the target profile.

If the plow starts substantially below the target depth, the target profile will initially rise at an aggressive pitch to reach its target depth, and then level out.

The overhead map continuously updates to show your current location in relation to the path.

## On-grade Indication

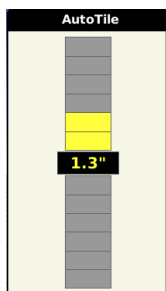

Intellislope displays how close the current installation point is to the target elevation.

This is similar to the arrows and on-grade signals displayed on laser masts. The distance off the target profile is indicated in inches shown as high or low. Otherwise “0.0” is displayed on a background of green.

If this indication shows the plow running consistently too deep, or consistently too shallow, (and it is set up as a pitch plow) then the Pitch Zero needs to be adjusted on the Machine Setup screen. Please see the section “Ongoing Pitch Zero Adjustment” for detailed instructions. If you are using a non pitch plow, GPS Gain can be adjusted.

## Stop Install

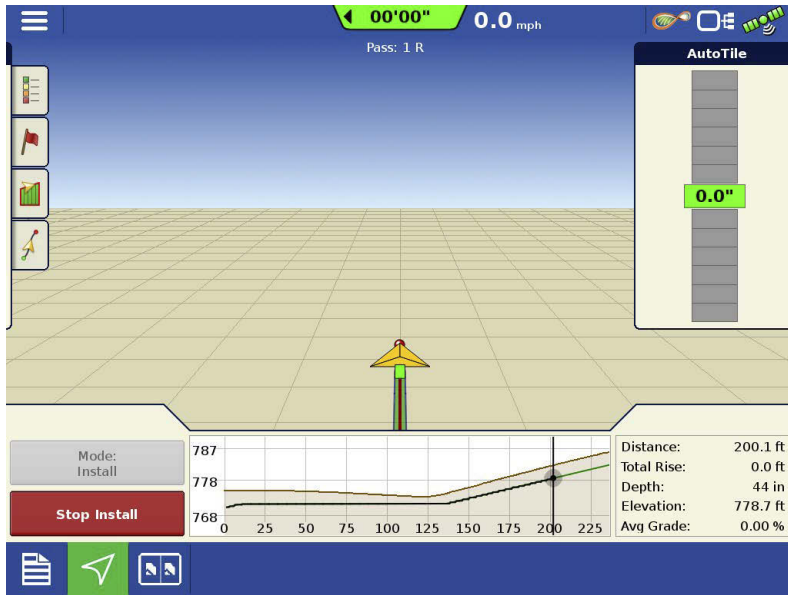

When reaching the end of the survey path, press the “Stop Install” button to finish the run and save the installation log.



To extract the plow, press the “Up” button to manually nose the plow up while pulling ahead to bring the plow out of the ground.

Never try to pick up the plow using the three-point hitch, or the wheel lift frame for a pull type, when it is in the ground. Always pitch the plow up and pull forward. When the cutting edge is close to the surface, use the wheel frame or three-point hitch to raise to transport position.

## Grade Control

If you have tiled with a laser, Grade Control should be natural. You select grade and grade break the same as with a laser. Grade Control is very similar in operation. The key advantage is that all adjustments are made in the cab instead of at the transmitter and mast.

## Running Grade Control

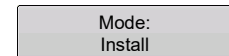
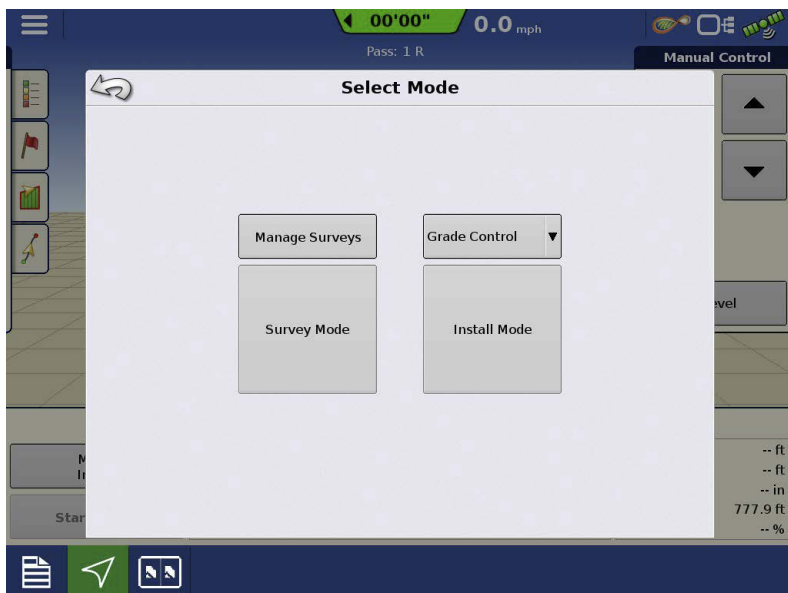

Press Mode Install button on the map screen.



On the Select Mode screen, select Grade Control. Then press Install Mode.

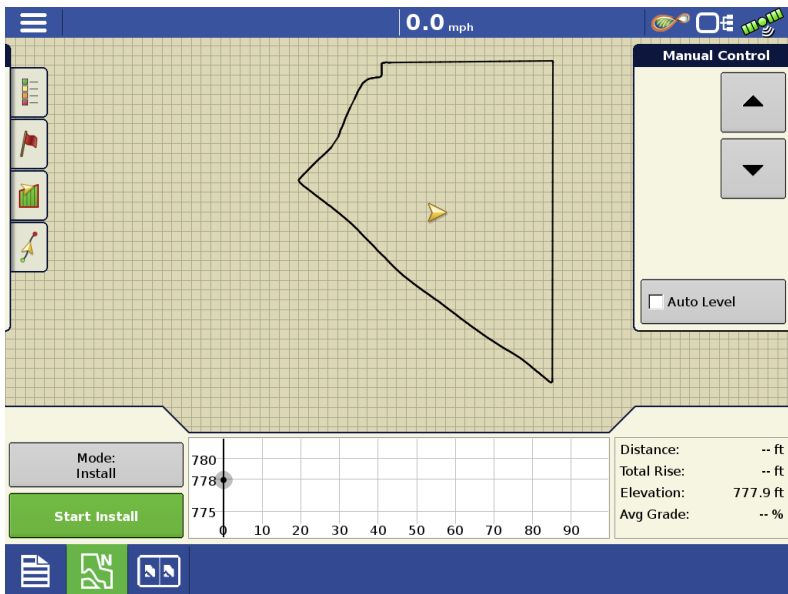
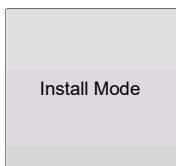

**“Up” and “Down” buttons**—used to raise or lower the cutting edge of the machine before engaging automatic control.

**Auto Level**—Automatically levels the cutting edge of the plow as it is lowered to its starting position (pitch plow).

**Start Install button**—Once the cutting edge of the machine has been lowered to its starting position,

pressing this button will cause Intellislope to control the Target Grade and Grade Break as the vehicle progresses forward.

When pushing autolevel make sure people are clear, as the machine will move.



After pushing Start Install, a dialog box will appear to set the starting Target Grade.

Press  to accept Target Grade. Once grade is accepted, the machine will automatically adjust as it is driven forward.

## Target

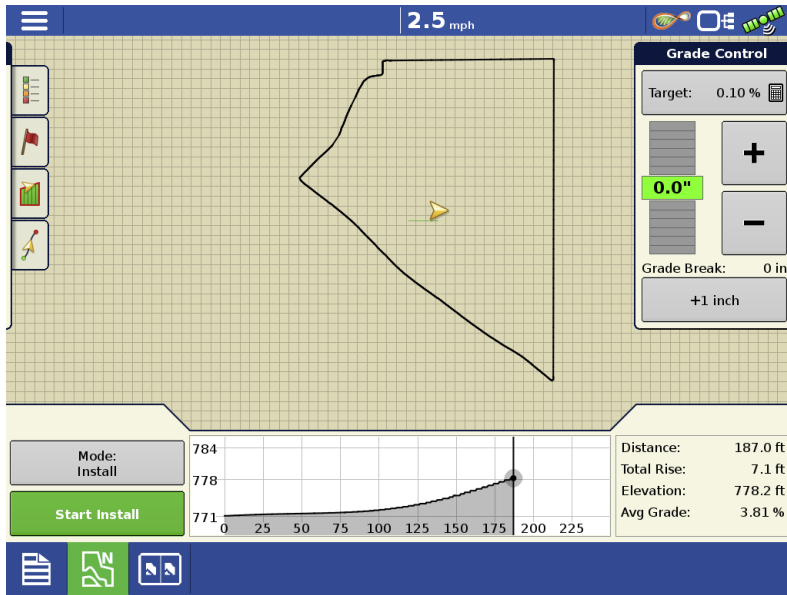

Use this button to select the grade you desire. You can change this setting on the fly, and Intellislope will follow the new grade starting at the point when the Target grade changed.

Use the + and - button to reach the desired value, or press the target button to enter the desired value on a keypad.

If you are installing uphill, you will need to set the target grade to a

positive number, if you are driving downhill, use a negative value.

(The laser equivalent to changing this setting would be: stop the tractor, relocate the laser to the new location, adjust it to the new grade, and resume installing.)

**Grade Break**—This gives you the ability to add a vertical offset to the tile profile which makes the plow run shallower. Use this if you are too deep. The current Target Grade is otherwise maintained. An example of a common use for this is if you had a flat run at 0.1% grade, went up a hill, and then flattened out again. You could leave the grade at 0.1% and then grade break up the hill until you get to where it flattens out.

## On-grade Indication

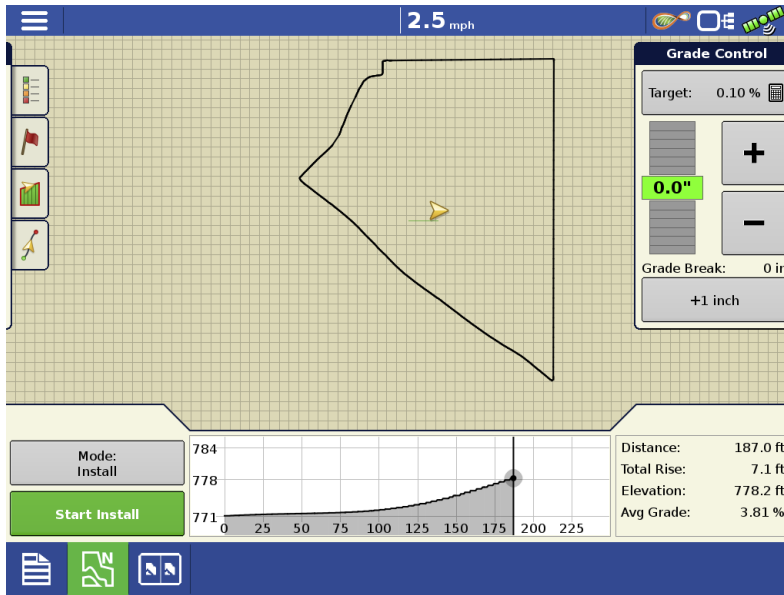

Below the Target button, Intellislope displays how close the current installation point is to the target elevation.



This is similar to the arrows and on-grade signals displayed on laser systems. The distance off the target profile is indicated in inches shown as high or low. Otherwise “0.0” is displayed on a background of green.

If this indication shows the plow running consistently too deep, or consistently too shallow, (and it is set up as a pitch plow) then the Pitch Zero needs to be adjusted on the Machine Setup screen. Please see the section “Ongoing Pitch Zero Adjustment” for detailed instructions.

If you are setup as a Non pitch plow, and you are running too high, you need to adjust the GPS gain as a lower value, if you are running too low, you need to adjust to a higher value.

Noise or error in the GPS elevation, noise in the pitch signal, rocks, soft spots, some degree of control system hunting and overshoot, among other things, can cause brief deviations from on grade. Only when the plow is consistently high or low does the Pitch Zero need adjustment.

Press  to end installation.

-  To extract the plow, press the “Up” button to manually nose the plow up while pulling ahead
-  to bring the plow out of the ground.

Never try to pick up the plow using the three-point hitch, or the wheel lift frame for a pull type, when it is in the ground. Always pitch the plow up and pull forward. When the cutting edge is close to the surface, use the wheel frame or three-point hitch to raise to transport position.

## Pitch Control

Pitch Control mode is only applicable for pitch plows. Other types of machinery should not attempt to use this mode.

Pitch Control is a fall-back mode of operation which may be used when GPS is unavailable. Keep in mind that:

- The Pitch Zero must be calibrated and correctly adjusted.
- Always prefer Grade Control or AutoTile mode when GPS is available. Pitch Control mode does not use GPS. It merely holds the plow shank at a specified pitch based off the WMC.
- Do not depend on the installed grade matching the pitch with better than 0.5% accuracy.
- Entering the incorrect pitch with a pull type plow may result in the plow emerging from the ground, and be unsteady, possibly resulting in the plow tipping on its side.
- Always use visual depth and pitch to verify plow operation.

## Running Pitch Control

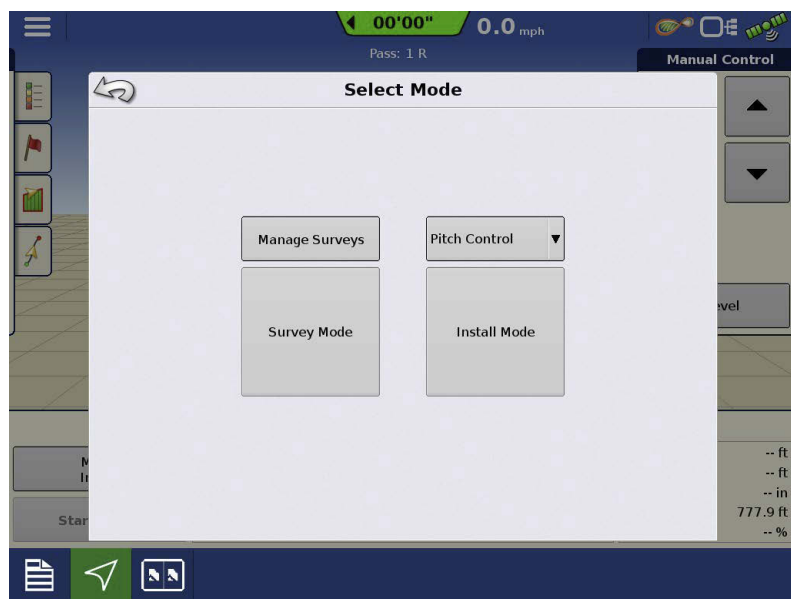

Press the Mode button on the map screen.



Select Pitch Control.

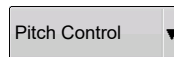

Select Install Mode

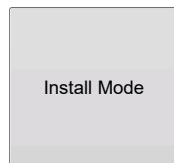



# Intellislope® Tile Plow Control System

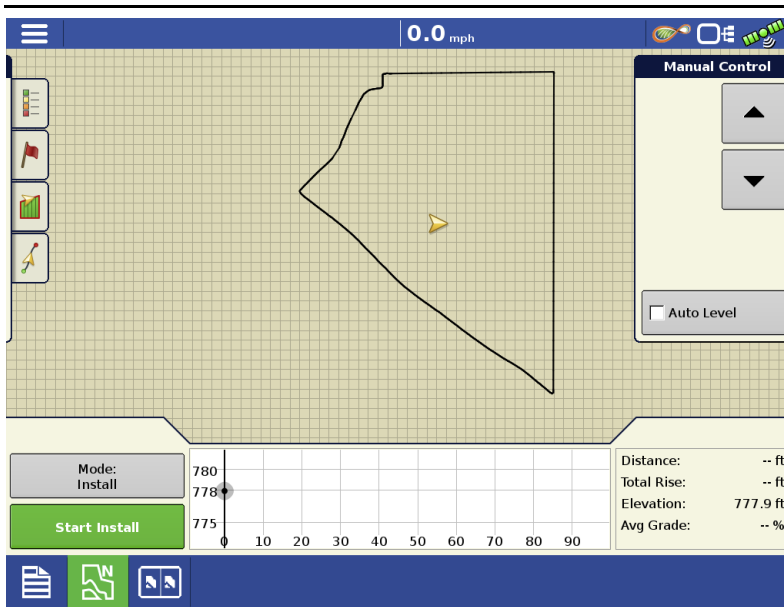

Press Start Install button to begin Pitch Control.

A keypad will be displayed to enter the desired starting pitch. When you accept this starting value, the machine will respond to the display, so ensure by-standards are not in the way.

The “Up” and “Down” buttons will be visible and can be used to move the cylinders prior to starting install. Use AutoLevel to level the plow at the start

of the run. If the implement is in the ground, do not use the AutoLevel.

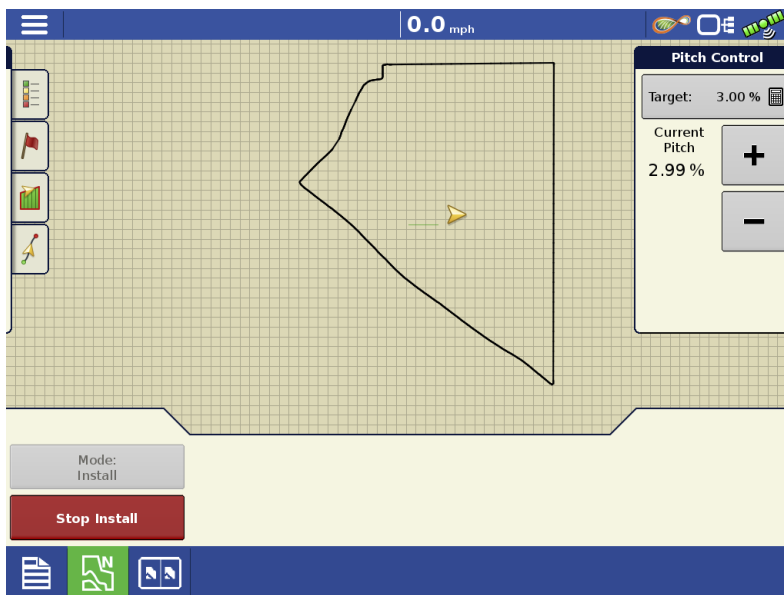



Use + and - buttons to raise and lower pitch or use Target button to enter a numeric value for pitch.

The installation grade will be approximate the plow shank's pitch.

The module slope sensor will match to the provided Target Pitch.

Press **Stop Install** to end Pitch Control.

-  To extract the plow, press the “Up” button to manually nose the plow up while pulling ahead
-  to bring the plow out of the ground.

Never try to pick up the plow using the three-point hitch or the wheel lift frame for a pull type, when it is in the ground. Always pitch the plow up and pull forward. When the cutting edge is close to the surface, use the wheel frame or three-point hitch to raise the plow to transport position.

# Diagnostics

## Devices



Press  to open the Devices screens. Technical support may request that you look at these screens for help in diagnosing a problem.

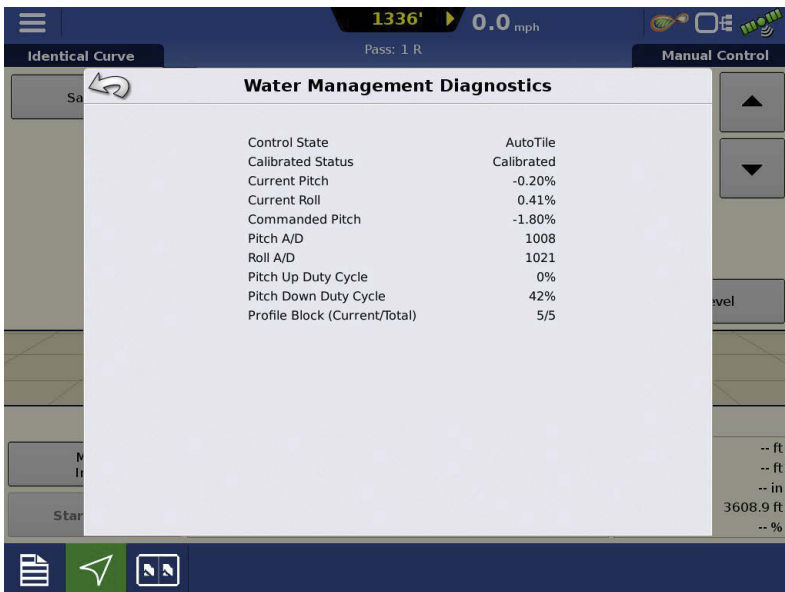

## GPS



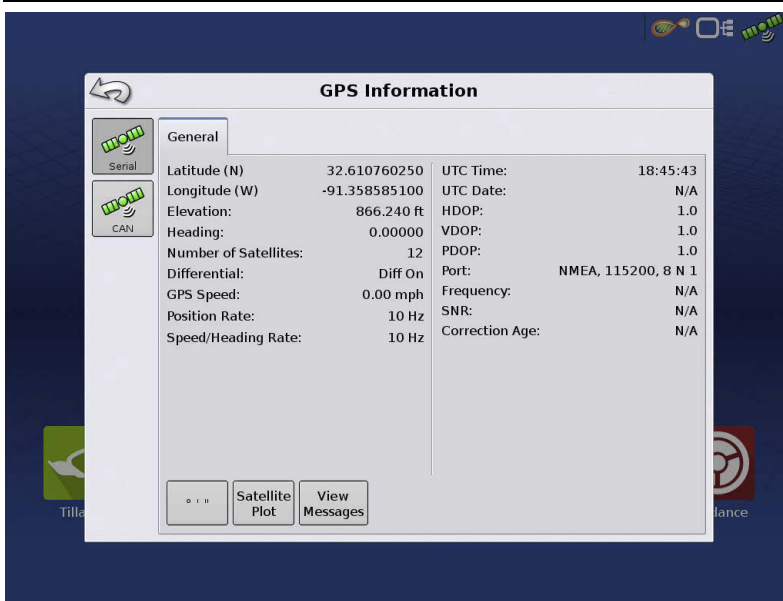

During your field operation, the GPS (satellite) button in the upper right-hand side of the Status Bar should appear as green, which means you are receiving a differential GPS signal. If this icon appears yellow, you are still receiving GPS but are not receiving a differential signal; and if it appears gray then you have lost GPS. In either case, you should check your GPS settings.

The two buttons on the top left will appear if the display is receiving GPS signals from two GPS receivers (one from plow-CAN, one from vehicle -serial, or Ethernet).

## Lessons Learned and Pitfalls to Avoid

The following is a list of pitfalls that we've observed and can degrade performance. Operators should be aware of these to better avoid them, and should be alert to the on-grade indicator and installation profile to detect when these conditions arise. Some are under the control of the operator while others are not, such as hitting rocks and loss of GPS fix or quality. The list is provided on a best effort basis; it may not be exhaustive. Should an installation error occur, it is straightforward to correct by installing a bypass around the affected section of tile.

**Extreme Soil Conditions**—Hard clay soil, loose already-plowed soil or soft bottoms can interfere with the ability of the shank's trajectory through the ground to be controlled by the shank's pitch. Normal operation requires that the pitch of the shank guide the trajectory. Soil that has been overplowed and is loose does not generate sufficient force acting on the shank surfaces to allow pitch to control the elevation.

**Tractor Effects**—A tractor effect is an interaction between the tractor and plow that can push the plow off the target. One such effect occurs as the wheels of the tractor pass over a sharp hump, trash from previous plowing or any uneven surface, the plow hitch will be similarly raised or lowered, pulling the plow frame with it. Pitch control will compensate, however the hydraulics can only fill the cylinders so fast, and so they may not keep up. To allow the system to keep up, drive over any uneven surface as slowly as possible.

---

**Low Hydraulic Pressure**—Forces acting on the buried plow shank are large. In the face of these forces, the hydraulic cylinders actuating the plow shank must create large forces and thus high hydraulic pressure is required to displace them. Insufficient hydraulic pressure can leave the system unable to adequately control pitch. Lower pressure can also make the plow slower to respond as it slows down the rate at which the hydraulic cylinders fill.

Older tractors may have open-center hydraulic systems in which hydraulic pressure is proportional to engine RPM, so at low RPM there is insufficient pressure. Modern closed-center hydraulic systems are pressure regulated and are not subject to this problem.

**Failure to Float the Three-point Hitch or Wheel Frame**—The plow needs to float and freely pivot as it goes through the soil. Force exerted from the three-point hitch, or wheel frame on pull type plows will displace the plow from the target depth. Always ensure the three-point hitch, and wheel frame are in the "Float" setting before beginning installation.

**Operating Too Shallow**—(less than ~20 inches), and Pull-type Plow Down Pressure

Forces bearing upon the top of the shank allow it to drive deeper when required by control logic. When too shallow, this force can be insufficient.

Related to this issue is the down pressure in the wheel cylinders of a pull-type plow. When shallow operation of a pull-type plow is required, the valve setting on the down-pressure cylinders should be lowered. Too much up pressure can also lift the plow up from the target profile.

The down pressure, depth of operation and soil conditions may interact such that some soil may require deeper operation or lower down pressure than other soils.

**Driving Too Fast**—When an installation is started with the plow much deeper than the target profile, the system will schedule a target that rises rapidly towards the target profile. When this steep section meets the relatively-level target profile, driving too fast can cause the plow to overshoot the target, as the cylinders can only change the plow pitch so fast. Drive slowly when the target profile grade is changing rapidly.

**Obstructions**—If you encounter a rock or other obstruction in the field use the Stop Tiling button, and end the install. After you have freed the plow from the rock you are now able to continue tiling. If using Grade Control Mode, you can use the Grade Break to raise the target depth to prevent a flow reversal in the tile. If you were using Autotile, re-select the survey, and adjust the

# Intellislope® Tile Plow Control System

---

depth settings to create a new target depth. This may include lowering the Minimum depth value, lowering the grade, or lowering the max depth value.

**Detuned Configuration Parameters**—The pitch gain, look ahead distance, valve thresholds, start compensation and pitch zero settings are discussed in “Water Management” on page 10. Low gains and valve offsets can make the plow respond too lazily, and setting them too high can induce instability.

**GPS Interruptions**—The elevation control is only as good as the ability of GPS to report elevation. Loss of GPS fix or quality, or change in satellite constellation can cause the GPS to report erroneous elevations. If using a battery-powered RTK base station, the battery can run down leaving the unit without correction.

**Defective Components**—A rusty/dirty hydraulic valve is an example of a bad component that can degrade performance. Of course as with any electro-mechanical system. Ensure that when connecting hydraulic lines to the tractor, that the tips are clean before connecting them. Intellislope components are not immune to failure. Most component failures lead to the system being inoperative, not degraded performance.



## Planting Section Control

By configuring your display with Planter Section Control, you can start and stop seed flow and control planter sections row-by-row, allowing AutoSwath™ Control to automatically turn planter row units on and off based on your planting map.

### Map View

Once a configuration has been completed, the Map View screen appears.

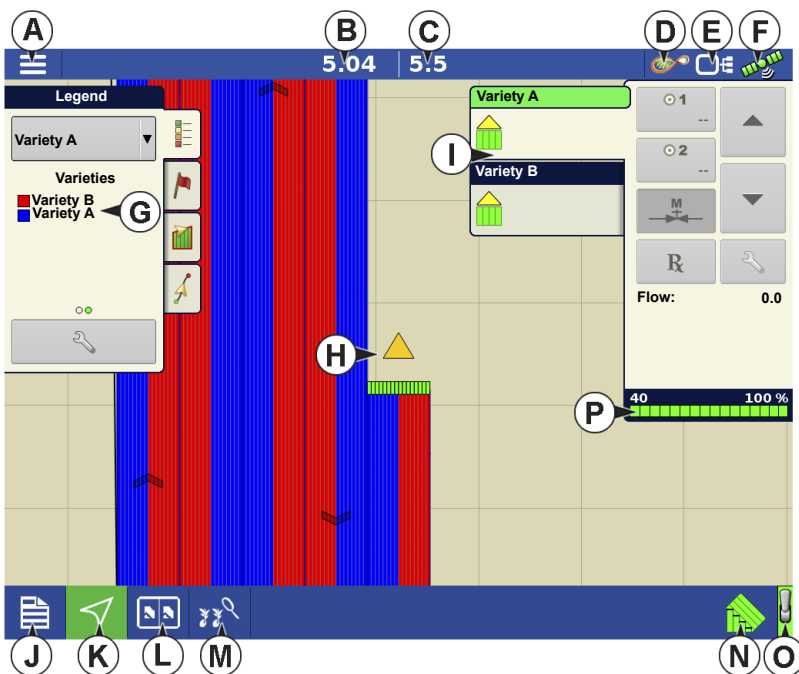

- A.Menu button
- B.Total Logged Field Area
- C.Ground Speed
- D.AgFiniti® Status
- E.Diagnostics
- F.GPS Signal Indicator
- G.Display Legend
- H.Vehicle Icon
- I.Product Control toolbox
- J.Event Summary
- K.Map View

L. Split screen

M. Advanced Seed Monitoring

N. AutoSwath

O. Master Switch Status

P. Section Status Indicator



**NOTE!:** Pressing the Map View button will cycle between the available Map Screen views, and the appearance of the Map View button changes.

---

## Create Configuration

A wizard will guide you through the process of selecting or creating a configuration with application settings.

The configuration can be started in two places:



OR

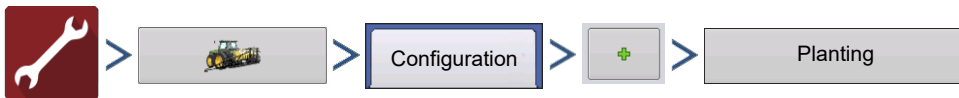

Your Operating Configuration will then be viewable when you start a new Field Operation with the Planting Operation Wizard.

You can also use the **Manage Equipment** button to create or edit specific vehicles and implements.

## Load Configuration



Press the Planting App from the home screen. This will take you through the steps needed to load a configuration.

## Creating Products

Creating planting products can be completed during initial setup or from the Product Selection screen of the Field Operation Wizard when starting a field operation.

Follow described steps to create planting varieties during initial setup.



1. Select **Product Type** (Crop) and **Product Units** (seeds or pounds)
2. Enter **Variety** or **Hybrid** name

Press  to enter a unique name for the variety or hybrid.



3. Enter **Variety** or **Hybrid Manufacturer** is applicable

Manufacturer name can be added to the drop-down menu by pressing .

4. Press  to complete Product setup.

Created variety or hybrid should appear under the Planting heading located on the Product tab of the Configuration Setup Screen.

## Configuration Setup

Once the configuration is created and it appears on the Configuration Setup screen, AutoSwath should be configured correctly. However, if you cannot get the configuration to load on the Field Operation Wizard, or if your vehicle does not appear on the Map screen, you may wish to check if the row clutches have been correctly set up in Implement Setup. Use the following procedure to enable Seed Row Shutoff and/or configure the Clutch Module.

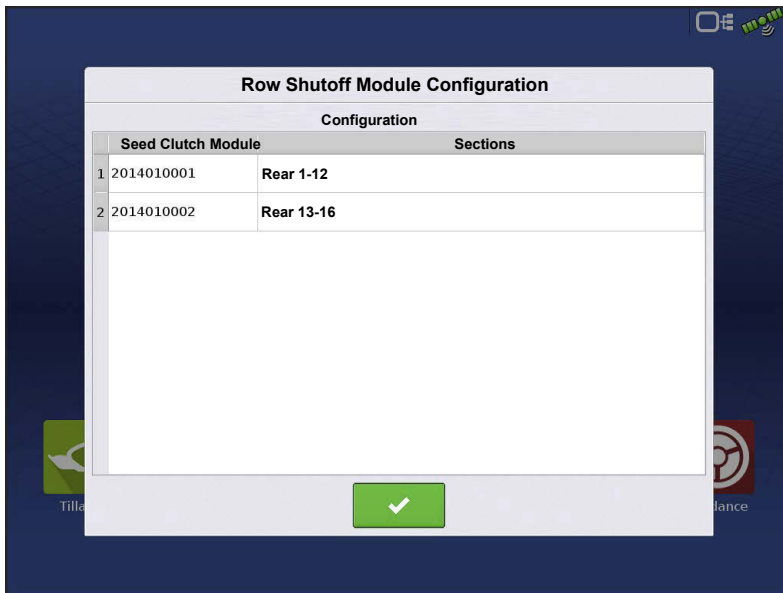

### The Row Shutoff Module

Configuration screen appears. This screen shows the number of Row Shutoff Modules and the sections that each module controls.

 **NOTE!:** If you receive the message “**Configuration Failed. The number of detected module outputs does not equal the number of planter sections.**” refer to the

Troubleshooting section of this User Guide.

## Automatic AutoSwath Control

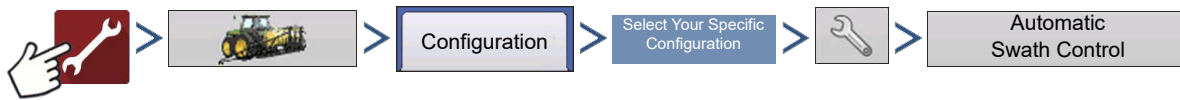

OR

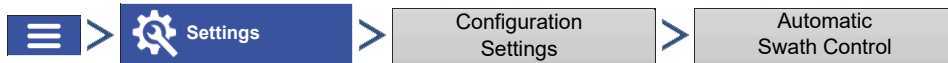

**NOTE!:** To use AutoSwath for planting operations, you are required to use a 5 Hz or higher GPS output rate. AutoSwath control will not allow sections to be turned on until the master and planting section switches are on. If you have less than a 5 Hz GPS output rate and you select AutoSwath, a warning appears, telling you that AutoSwath Control is not available at less than 5 Hz.

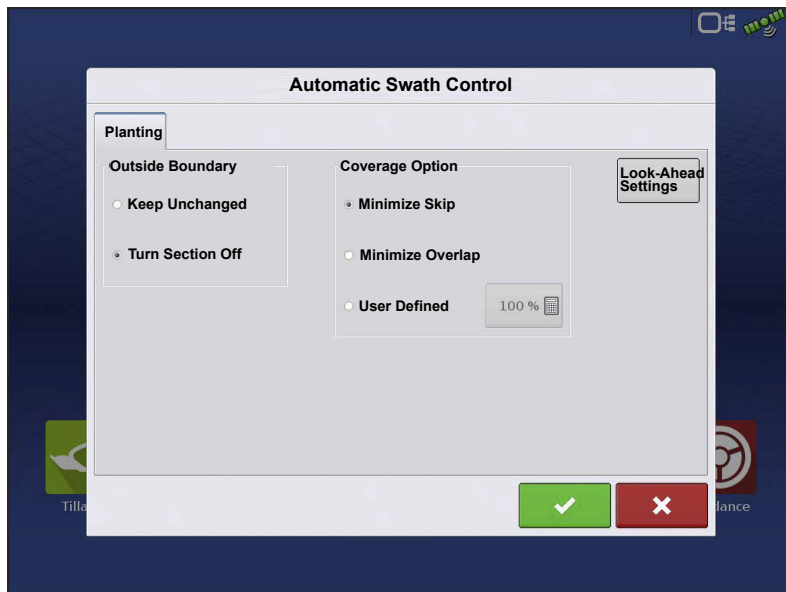

The Automatic Swath Control feature turns sections off and on automatically based upon the following conditions:

- Entering and exiting internal and outer field boundaries.
- Entering and exiting previously-applied areas within a field.

**Outside Boundary Option**—Select one of the two options to determine system behavior when a section exits

a field boundary.

- **Keep Unchanged**—Clutch section on/off status will not change when exiting the field as defined by the outside boundary.
- **Turn Section Off**—Clutch section will cease planting when exiting the field as defined by the outside boundary.
- **Coverage Option**

In the Coverage Option area, you must choose between three options:

- The **Minimize Skip** option turns off the implement section after the entire section is fully inside your coverage area. This prevents the possibility of skips.
- The **Minimize Overlap** option turns off the implement section when that section first enters your coverage area. This prevents the possibility of overlaps.
- The **User Defined** option allows you to choose what percentage of the implement section is within the coverage area before that section turns off. For example, if you choose 50%, then the section will switch off when half of it is within your coverage area.

## Look-Ahead Settings

AutoSwath Control settings are saved per controller per configuration. There can be different Look-Ahead settings saved for equipment of the same operation. The Look-Ahead Settings screen will contain every controller's Look-Aheads.

On the AutoSwath Control screen, press the Look-Ahead button.

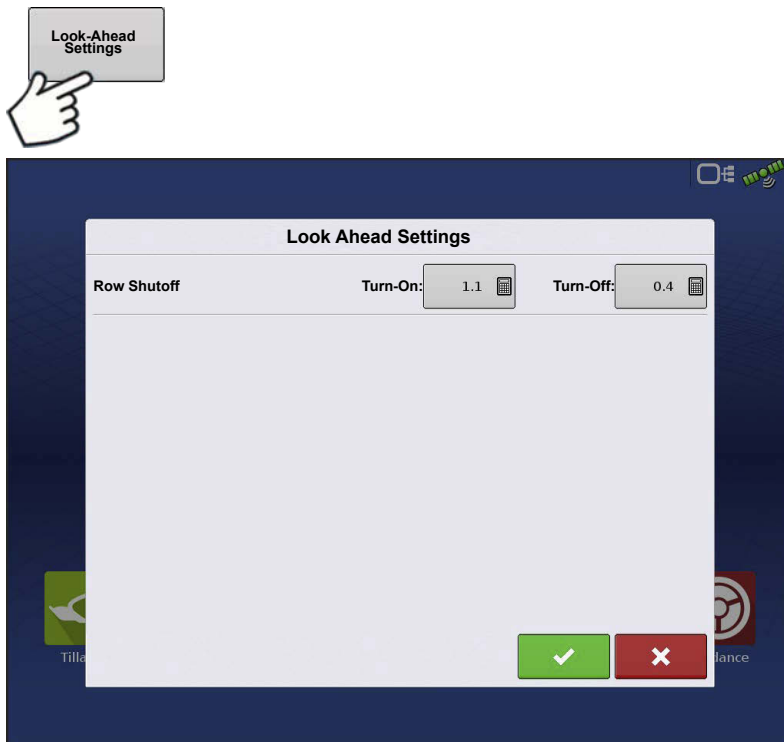

**Turn-On**—This setting determines how far ahead the system looks to turn the sections back on. This setting compensates for delay in the planting control system when the implement sections are turned on.



**ATTENTION!** For best performance, do not change travel speed as you are entering the unplanted area. Accelerate either well

before entering the unplanted area, or after all clutch sections have turned On.

**Turn-Off**—This setting determines how far ahead the system looks to turn the sections off. This setting compensates for delay in the product control system when the sections are turned off.



**ATTENTION!:** For best performance, do not change travel speed as you are nearing the planted area. Decelerate either well before entering planted area, or after all clutch sections have turned Off.

## Row Shutoff Look-Ahead Numbers

This table references the Turn-On Look-Ahead and Turn-Off Look-Ahead numbers for both Electric Clutch and Air Row Shutoff Modules.

Planter Unit Seed Meter Type	On/Off	Electric Clutch	Air Clutch
Finger Units	Turn On	0.9	1.1
	Turn Off	0.3	0.3
Vacuum	Turn On	0.9	1.1
	Turn Off	0.4	0.4



**NOTE!:** Using the above settings should produce good field results. However, always take the time to check for proper seed placement in the field and make system setting adjustments as needed. Do not rely solely upon the appearance of the On-Screen map. The on screen map will not show gaps and overlaps caused by incorrect GPS Offsets or AutoSwath Look-Ahead settings.

## Checking AutoSwath Performance for Row Shutoff

The settings given in the above AutoSwath Look-Ahead table shown previously have been tested with each clutch and seed meter combination to work for your planter. However, always take the time to check for proper seed placement in the field and make system setting adjustments as needed. Do not rely solely upon the appearance of the On-Screen map. The on screen map will not show gaps and overlaps caused by incorrect GPS Offsets or AutoSwath Look-Ahead settings. Verify settings with the following procedure:

1. Stop the planter within 20 feet of the planted headland.
2. Select one row unit from each planter swath section to observe.
3. Remove the down pressure from the closing wheel of each selected row unit.

- 
4. Hold the closing wheels off the ground by attaching a chain or strap from the hopper support panel to the closing wheel arm. (This prevents the closing wheels from closing the seed trench).



**NOTE!:** Securing these closing wheels up allows you to observe the planted seed in the trench so that you can observe when the AutoSwath is turned off and on during the seed application.

5. Resume planting in your normal fashion, then stop when you are 20 feet out of the headland of the next pass.
6. Stop the planter and observe the AutoSwath shutting off and turning on to see if the results are acceptable.
  - If the results are correct, then return the closing wheels to their previous operational state. Close the seed trench on the observed rows and return to planting.
  - If you suspect the results are incorrect, then adjust the appropriate Look-Ahead setting one-tenth (.1) second per trial. Larger adjustments can cause unintentional large changes in the AutoSwath's performance. When adjusting the Look-Ahead numbers from the suggested settings, it is recommended that you observe multiple trials to confirm the operations' accuracy.
  - If you encounter overplanting or underplanting problems, see "Fixing Overplanting and Underplanting in AutoSwath" in the TroubleShooting section.

## Auxiliary Input

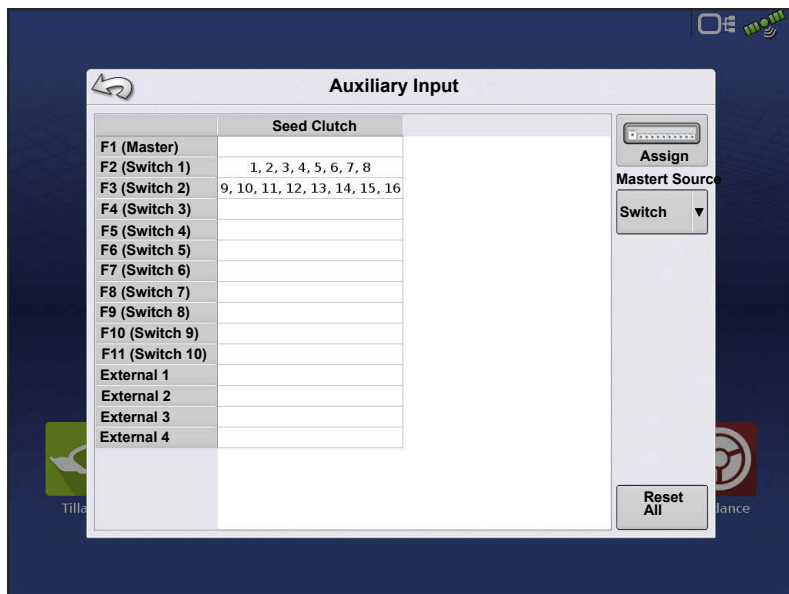

Clutch control planter sections will default to the first two switchbox switches with a planting operation. AutoSwath will still trigger sections on/off by each section in a planting application. If the operator would like to turn section(s) on/off by a single switch, the sections will need to be assigned.

1. Press

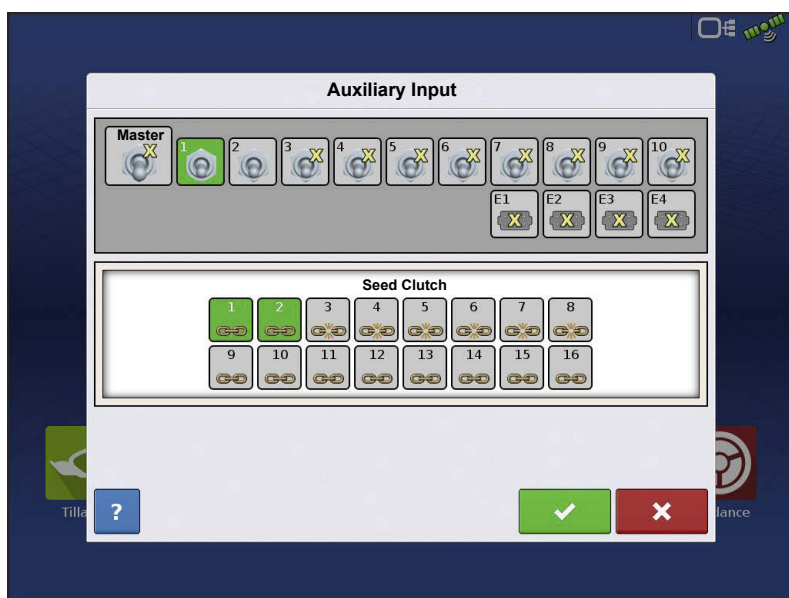
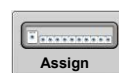

2. Highlight the desired switch to assign a function to it.

3. Select appropriate function(s) (clutch sections for this operation) to assign to the desired switch. Chain icons with in each function will "link" once pressed to indicate they are assigned. If a function has a "broken link" then it is not assigned. If a switch has a "X" then it is not assigned to a

function. Press the  to save the

setup.



**NOTE!:** Even if no specific functions are assigned to the Master switch, the Master switch will still serve as the total system on/off switch.

## Clutch Diagnostics



highlight the item marked **Seed Clutch Module**

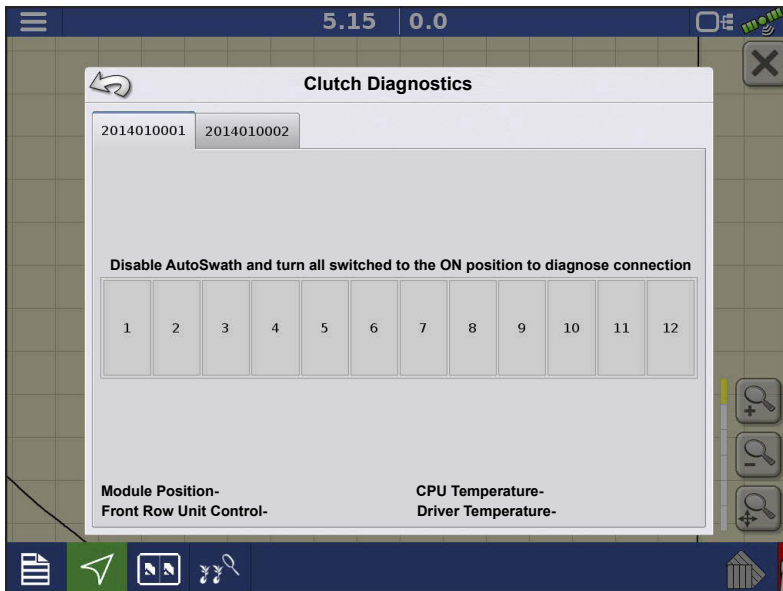

There will be a Seed Clutch Module in the CAN A tab for each module on the CAN BUS.

The Clutch Diagnostic screen includes section status for the module. If there are multiple clutch modules, there will be a tab for each identified by the Serial Number. This screen can be used to diagnosis section status, and what sections are mapped to specific switches. If a section is Off the

indicators will be gray, if the section is On the indicators will turn green.

## Troubleshooting Planter Section Control

**Problem**—Receiving the message “Configuration Failed. The number of detected module outputs does not equal the number of planter sections.”

**Solution**—The number of detected clutch sections by the module(s) does not match the sections setup in the configuration.

1. Verify the configurations clutch sections is setup to match the planter setup. The number of clutch sections is determined by the clutch adapter cable plugged into the module.
2. If the number of sections detected is less than what it's supposed to be, check for wiring damage leading to the first failed section. (Ex: On an 8 row planter with 8 clutch sections, if sections 1-6 are detected, check the wiring going to section 7). A clutch may not be plugged in, or wires damaged.

---

3. If the number of sections detected indicates "0-0" verify high power (12V) going to the clutch control module. Also verify the high power "T" connection leading off the adapter cable is connected.

- If 12V is verified at the clutch control module, check for wiring damage leading to the first clutch section.



**NOTE!:** Testing for 12V will be done at the 2-pin duetsch connections.

## Fixing Overplanting and Underplanting in AutoSwath

### AutoSwath Function—Turn Off Look Ahead

**Problem**—Underplanting

**Recommended Action**—Decrease Look-Ahead number

**Result**—The AutoSwath anticipates headlands later and turns the planter off later.

**Problem** — Overplanting

**Recommended Action**—Increase Look-Ahead number

**Result**—The AutoSwath anticipates headlands sooner and turns the planter off sooner.

### AutoSwath Function—Turn On Look Ahead

**Problem**—Underplanting

**Recommended Action**—Increase Look-Ahead number

**Result**—The AutoSwath anticipates headlands sooner and turns the planter on sooner.

**Problem**—Overplanting

**Recommended Action**—Decrease Look-Ahead number

**Result**—The AutoSwath anticipates headlands later and turns the planter on later.



## Load Configuration



Press the Planting App from the home screen. This will take you through the steps needed to load a configuration.



**ATTENTION!:** If a configuration is loaded for the first time, the user will be presented with a warning message indicating that the Seeds/Rev setting needs to be reviewed. Proceed to the Planter Options screen to enter the appropriate Seeds/Rev value, see [Planter Options](#) on

[page 305](#). The Seeds/Rev value is required in order to control the planter rate. (If the Seeds/Rev value is left at 0, this warning message will appear each time an Event is created/continued)

## Map View

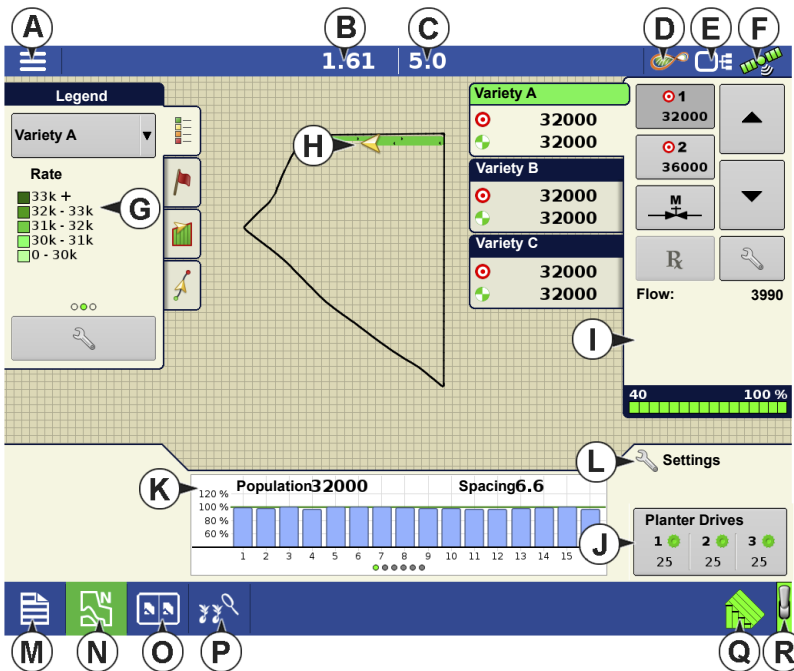

Once a configuration has been completed, the Map View screen appears.

A. Menu button

B. Total Logged Field Area

C. Ground Speed

D. AgFiniti® Status Indicator

E. Diagnostics

F. GPS Signal Indicator

G. Display Legend

H. Vehicle Icon

I. Product Control toolbox

J. Planter Drive RPM

K. Bar Graph

L. Settings button

M. Event Summary

N. Map View

O. Split screen

P. Advanced Seed Monitoring

Q. AutoSwath

R. Master Switch Status



**NOTE!** Pressing the Map View button will cycle between the available Map Screen views, and the appearance of the Map View button changes.

## Product Control Toolbox

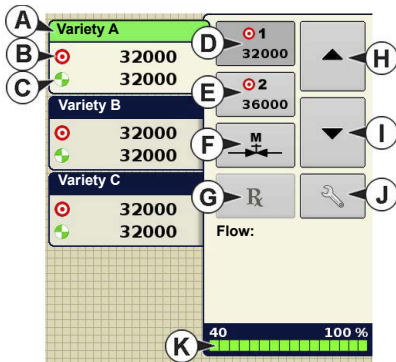

During SeedCommand® Run Time operations, the Product Tabs are shown in the upper right-hand side of the Map screen. Press the Product Tabs, and an extended view shows the Rate buttons, Manual Valve Control button, Prescription button, Rate increase and decrease arrows, and the Rate Setup button, all of which are described below.

- Variety**—The Product Control Toolbox can show rates for multiple varieties, depending upon the particular planting configuration. Press the area of the box that shows a particular variety, and a green bar highlights that variety. The Rate 1 and Rate 2 are then shown on the Rate buttons.
- Target Rate**—The Target Rate is the desired planting rate.
- Actual Rate**—The Actual Rate is communicated by the shaft rotation sensor.



**NOTE!** In some conditions, the Actual Rate may increment slower than the Target Rate, or its numeric values may vary before matching the Target Rate.

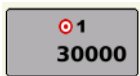

d. **Rate 1 button**

e. **Rate 2 button**

These only appear on Hydraulic Drive or Stepper Seed Meter configurations. The Rate 1 and Rate 2 settings represent preset planting rates that allow operators to quickly change between desired planting rates for each individual product. The active rate button appears with a gray background behind it. In the example above, Rate 1 is active.

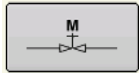

f. **Manual Valve Control**—The Manual Valve Control button allows operators to specify the position of the control valve. Operators use this option to clean out equipment at the end of the day.

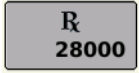

g. **Prescription button**

h. **Rate Increase arrow**

i. **Rate Decrease arrow**

Pressing once on / increments the rate according to the user-defined amount on the Rate Control Settings screen.



j. **Rate Setup button**—The Rate Setup button opens the Rate Control Settings screen.

k. **Section Status Indicator**

## Rate Control Settings



Press to adjust the Rate 1 and Rate 2 settings shown at the Product Control Toolbox on the Map screen, as well as import planting prescriptions. To access the Rate Control Settings screen, press the Rate Setup button on the Product Control Toolbox. The Rate Control Settings screen appears.

- The **Rate 1** and **Rate 2** settings represent preset application rates that allow operators to quickly change between desired target rates for each individual product. Press to enter the desired amount.

- The **Increment** button allows operators to specify the increase or decrease amounts for a specified rate when using / on the Product Control Toolbox. Press to enter the desired increment.

- To load a map-based prescription file, press .

## Loading Prescriptions

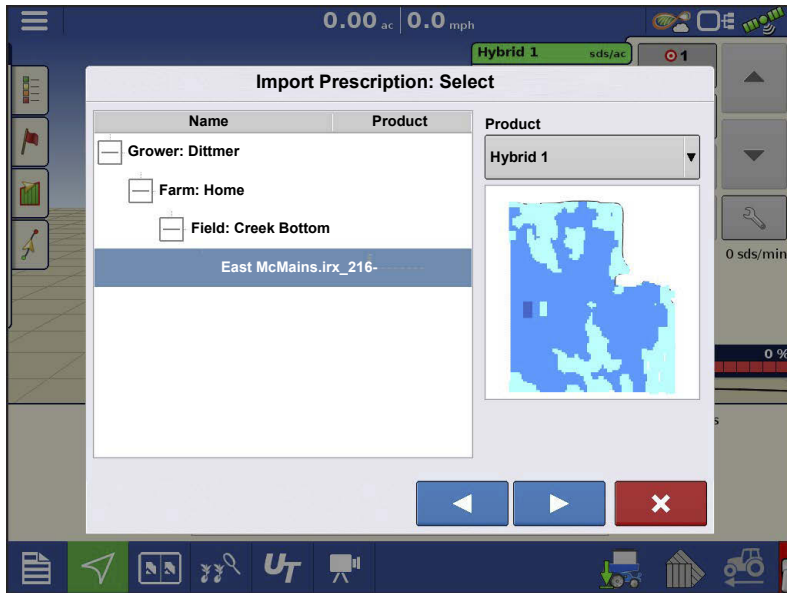

1. Press the Rate Setup button on the Product Control Toolbox.



2. Press the Load Prescription button.

3. Using an inserted USB or AgFiniti Cloud, search for and highlight the correct .agsetup, .irx, or shape file and press .

4. Select the prescription in the Select Prescription screen, and select the correct controlling product from the Product dropdown box. A preview prescription map is displayed. Press

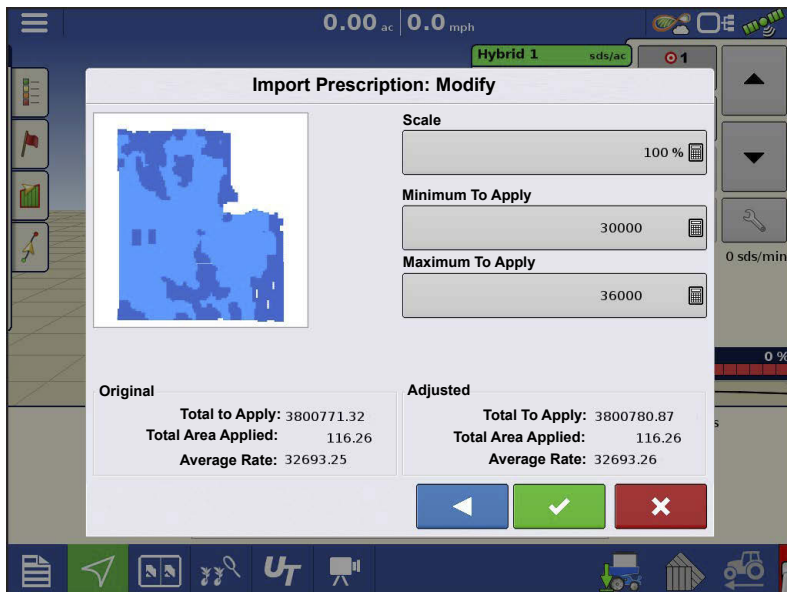

5. In the Modify Prescription Screen the prescription scale, minimum to apply, and maximum to apply can be changed. As the three parameters are changed, the adjusted total to apply and average rate will update accordingly.

6. Press the .

7. After returning to the Mapping Screen, the prescription will appear on

the map while in a North Oriented view.

## Shape File Conversion

What is commonly called a shape file is actually a collection of three different files. All three of the files are required and must be present on the USB drive for the system to use shape file groups for variable rate product application. A single "shape file" can contain recommendation rates for multiple products.

1. To begin, press  on the Product Control Toolbox.



The Rate Control Settings screen appears.



2. Press the Load Prescription button.

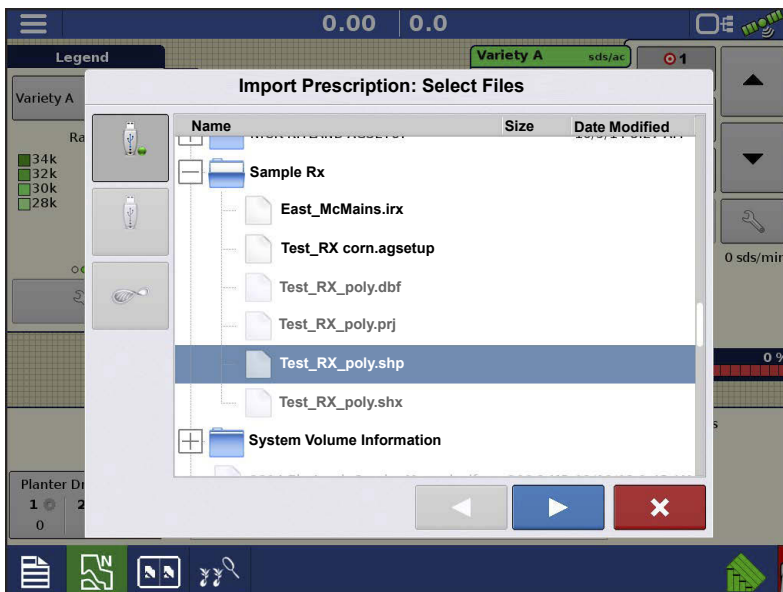

3. The Select File screen appears. Highlight your desired .shp file and press .

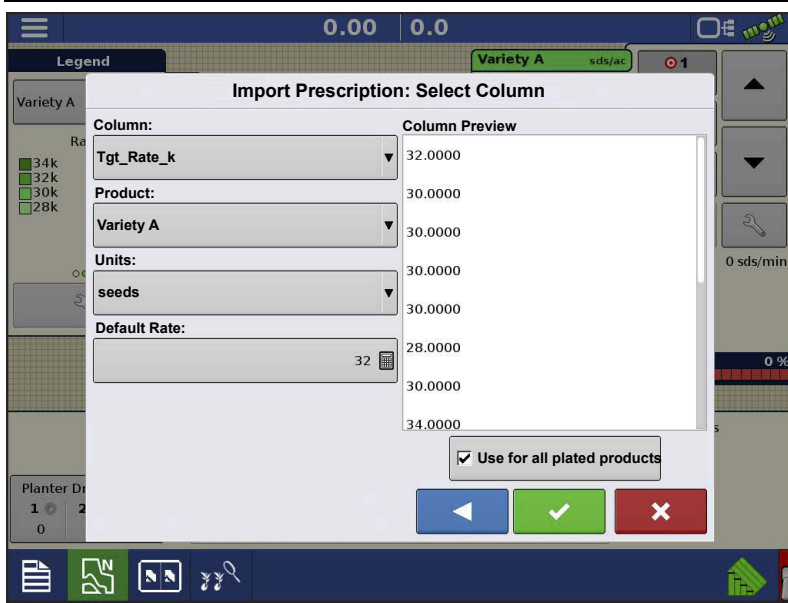

#### 4. Select Column From Shape File

Select the column that contains the product recommendation rate. The list on the right side of the dialog shows sample data from the selected column.

#### 5. Select Units

Select the controlling units for product application.

#### 6. Default Rate Setting

The system assigns a default rate. Use the on-screen keypad to edit the value if desired.



**NOTE!:** Select the product and units that the shape file prescription was made for. Selection of the wrong data column or unit will result in misapplication of product.



**ATTENTION!:** The only time the default rate is used by the system during product application is if the Rate Outside of Field selection is set to "Rx default". This setting is located in the equipment configuration settings portion of configuration setup. If the Rate Outside of Field selection is set to "Rx default", the default target rate will be used when the vehicle exits the area covered in the prescription map.

## Creating Products

Creating planting products can be completed during initial setup or from the Product Selection screen of the Field Operation Wizard when starting a field operation.

Follow described steps to create planting varieties during initial setup.



1. Select **Product Type** (Crop) and **Product Units** (seeds or pounds).
2. Enter **Variety** or **Hybrid** name.

Press  to enter a unique name for the variety or hybrid.

3. Enter **Variety** or **Hybrid Manufacturer** if applicable.

Manufacturer name can be added to the drop-down menu by pressing .

4. Press  to complete Product setup.

Created variety or hybrid should appear under the Planting heading located on the Product tab of the Configuration Setup Screen.

## Create Configuration

A wizard will guide you through the process of selecting or creating a configuration with application settings.

The configuration can be started in two places:



OR

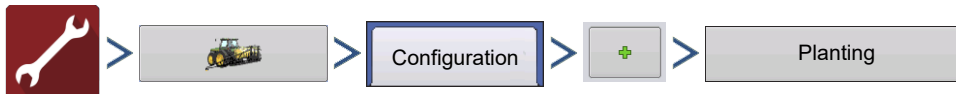

Your Operating Configuration will then be viewable when you start a new Field Operation with the Application Wizard.

You can also use the **Manage Equipment** button to create or edit specific vehicles and implements.

## Equipment Settings

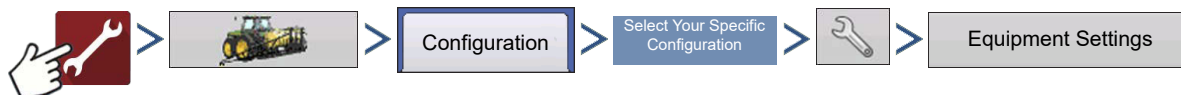

OR

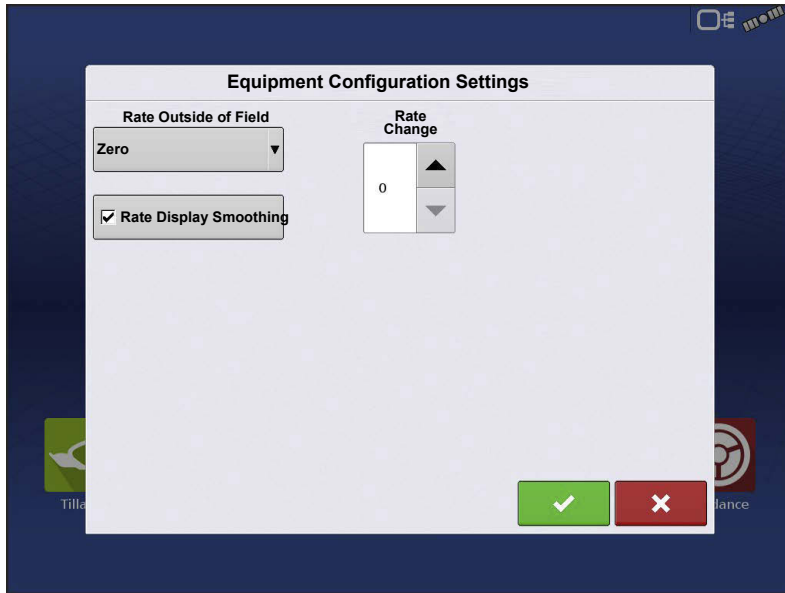

**Rate Outside of Field**—This setting will define how product will be controlled when leaving a field boundary.

- Zero**—This will stop planting.
- Last Good**—This will continue planting at the last known rate.
- Rx Default**—When using a prescription, this will apply at the Default Rate (or outside of boundary

rate) as defined by the prescription file.

**Rate Display Smoothing**—Determines how the feedback from the control channel rate sensor will be displayed on the map screen. When de-selected, the system will display raw feedback from the rate sensor. When checked, the system will display target rate when the planting rate is within 10% of the target rate setting.

**Rate Change Look-Ahead**—This setting compensates for any latency in the control system when changing between different product flow rates during variable rate planting. The typical setting range for this is 0-1 seconds. This setting can be thought of as a “look ahead” value when using a variable rate prescription. The display will send the signal to change rates before hitting a transition line so that the applied rate is correct when crossing into the new management zone.

## Auxiliary Input

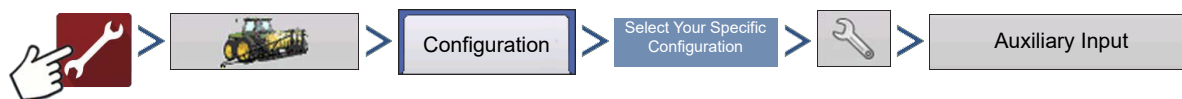

OR





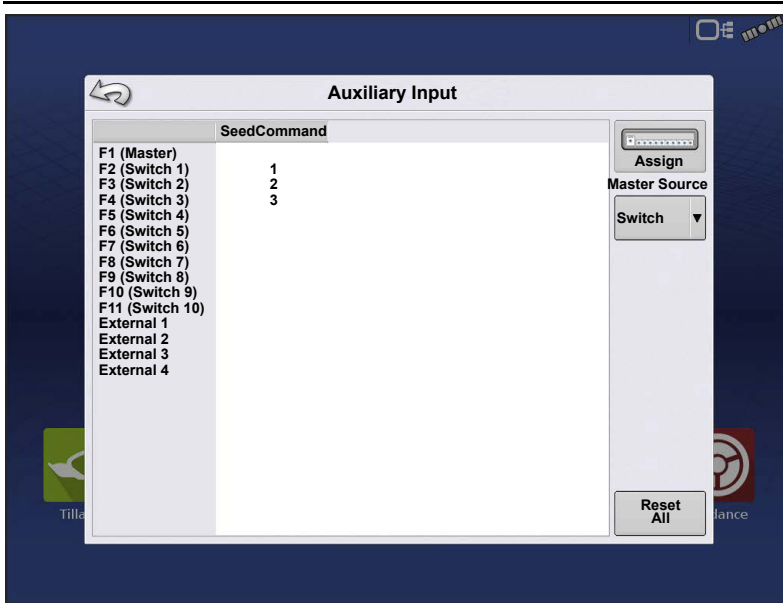

# Hydraulic Seed Rate Control

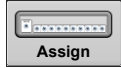

From the Auxiliary Input screen, the operator can customize the switches to the planter drives, if desired.

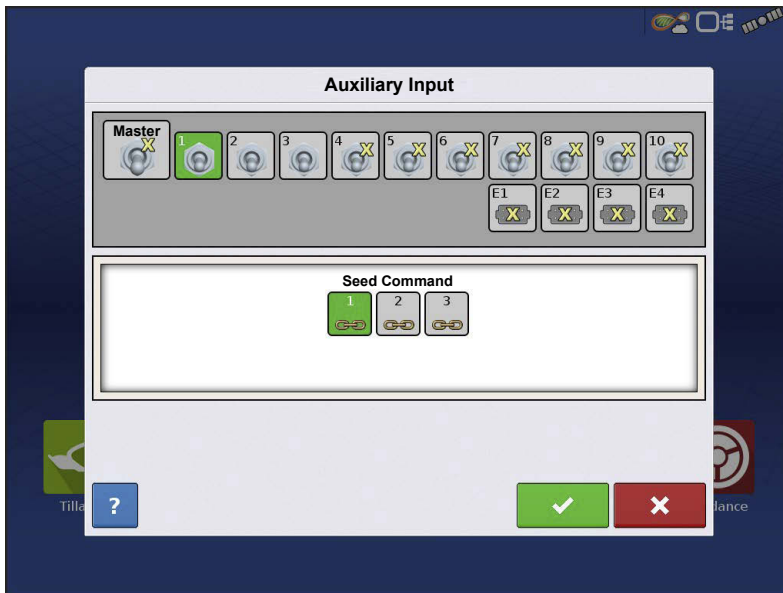
1. Press 
2. Highlight the desired switch to assign a function to it.



3. Select appropriate function(s) (planter drives for this operation) to assign to the desired switch. Chain icons within each function will "link" once pressed to indicate they are assigned. If a function has a "broken link" then it is not assigned. If a switch has a "X" then it is not assigned to a function. Press the  to save the setup.

 **NOTE!:** Even if no specific functions are assigned to the Master switch, the Master switch will still serve as the total system on/off switch.

---

## Hydraulic Seed Rate Control

The Hydraulic Seed Control Module allows operators to control up to three hydraulic motor drives with the display. Configure the Hydraulic Seed Rate Control module in the following order.

1. **Enter Controller Settings**—Include the Max Meter Speed, Gear Ratio and Minimum Allowable Ground Speed. See [Controller Settings for Hydraulic Seed Rate Motor Drives on page 294](#).
2. **Prime the Hydraulic Seed Meter**—Fill seed meter with seed to avoid skips. See [Priming Seed Rate Meters on page 306](#).
3. **Meter Calibration**
  - a. Enter Meter Calibration Number. This number, representing seeds per revolution, is set according to the number of seed dropped per one revolution of the seed meter.
  - b. Perform a Seed Meter Calibration. A new calibration should be performed if as-applied seed rate does not match actual population planted. See [Calibrating Seed Rate Meters on page 306](#).

### Controller Settings for Hydraulic Seed Rate Motor Drives

After creating an Operating Configuration for the Hydraulic Seed Meter Controller, make settings changes in the Controller Settings screen, which shows valve settings for hydraulic flow and pulses per revolution.

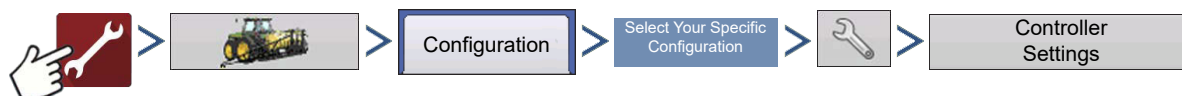

The Controller Settings screen consists of at least two tabs: the Channel Tabs, shown for each channel being controlled; and the Auxiliary Tab.

## Channel Tab settings

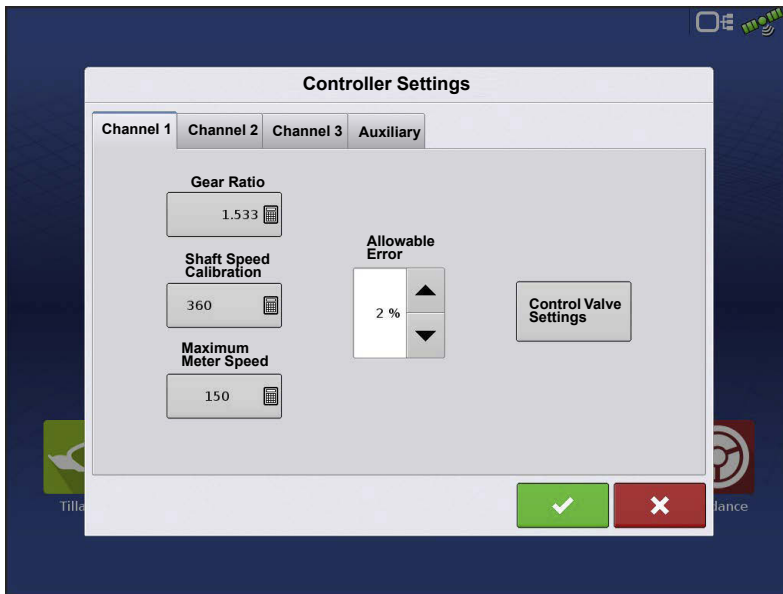

**Gear Ratio**—The number of time the hydraulic drive sprocket turns to achieve 1 revolution of the seed meter. This ratio is typically provided by the planter manufacturer. Otherwise use the formula in the examples to calculate Gear Ratio. See [Gear Ratio Calculations for Seed Rate Motors on page 301](#). Carry decimal to the nearest 0.001.

**Shaft Speed Calibration**—

Calibration number representing the pulses that equal one revolution of the hydraulic motor.

**Maximum Meter Speed**—Setting determines the maximum RPM of the seed meter.

**Allowable Error**—Determines the percent of error that is allowed prior to the product control system making any flow rate changes.

**Control Valve Settings**—This button summons the Control Valve Settings screen. The appearance of the Control Valve Settings screen varies, depending upon whether planter's control valves are PWM Valves or Servo Valves.

## Control Valve Settings - PWM

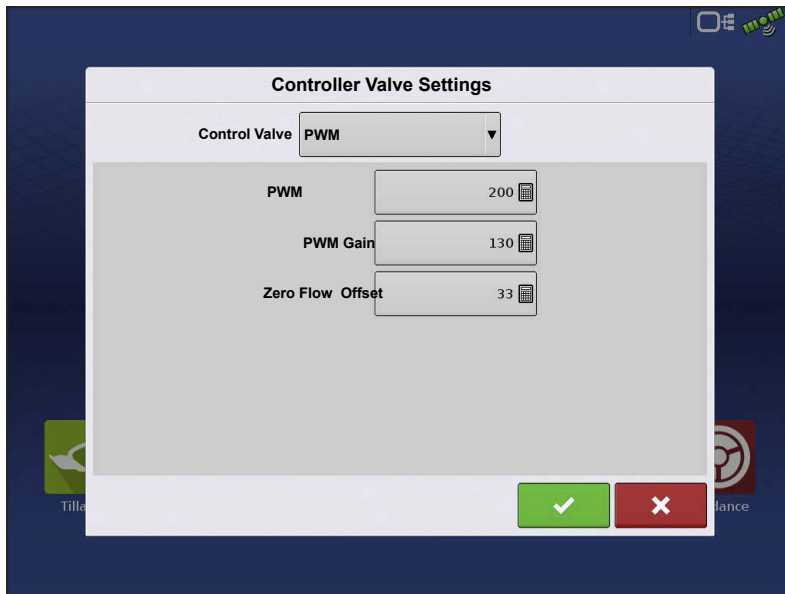

**PWM Frequency**—The frequency at which the PWM control valve is pulsed. Settings can be found from the manufacturer of the valve.

**PWM Gain**—Determines how aggressively the control valve responds when making rate change adjustments. The higher the value the more aggressive the system response.

**Zero Flow Offset**—Represents the maximum duty cycle that is sent to the control valve without producing any hydraulic flow from the PWM valve. Using too high of a Zero Flow Offset value can cause the product control system to not properly control flow rates at low rates. See the PWM valve manufacturer's information for recommended settings.

## Control Valve Settings - Servo

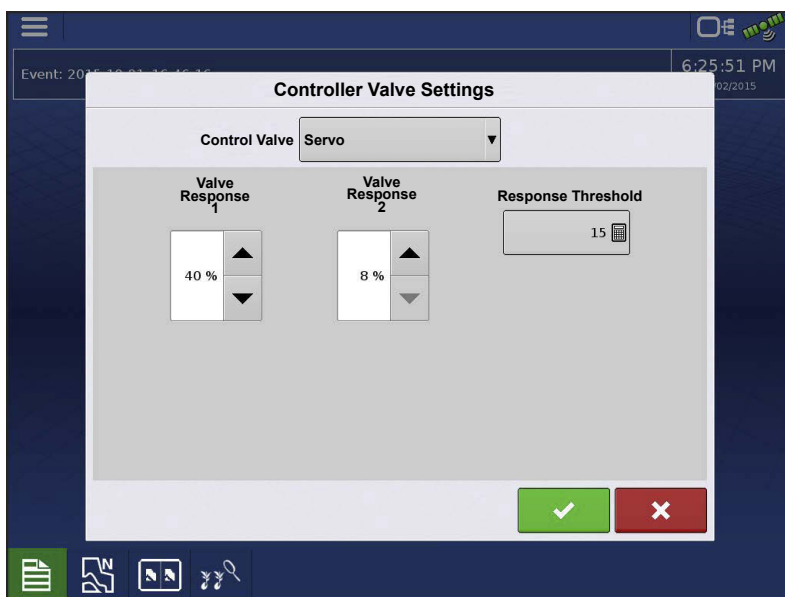

**Valve Response 1**—Determines the speed of the servo valve when product control error exceeds the Response Threshold setting.

**Valve Response 2**—Determines the speed of the servo valve when product control error is less than the Response Threshold setting.

**Response Threshold**—Determines the system responsiveness to rate change.

## Auxiliary Tab settings

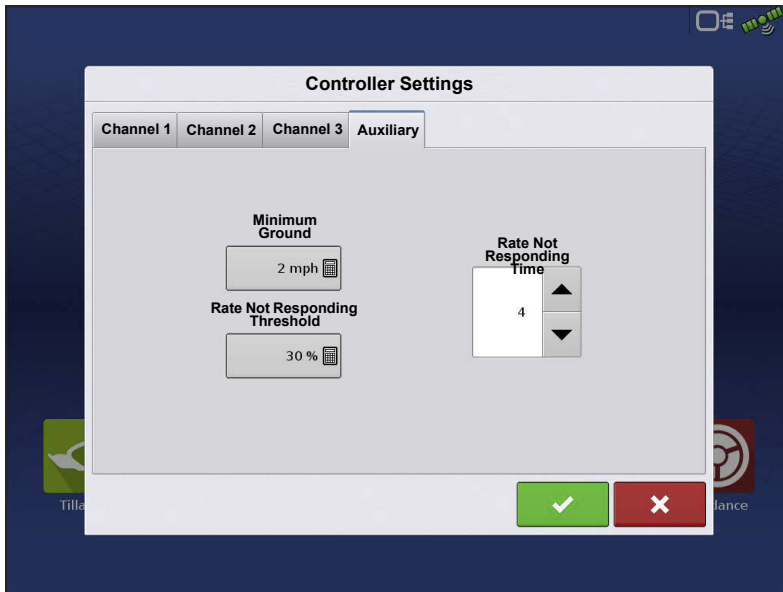

**Minimum Ground Speed**—The planter will plant at this simulated ground speed, until displayed ground speed is above this value. This fixed ground speed compensates for delays in acquiring an initial ground speed when starting from a stand still. Planting at the minimum ground speed will occur when either of the following conditions are met:

- Wheel motion is detected. Requires wheel motion sensor.
- Jump start switch is depressed. Required jump start switch kit.

**Rate Not Responding Threshold**—The percentage of seed rate error that triggers the alarms.

**Rate Not Responding Time**—The amount of time that the error occurs before the alarm sounds.

## Hydraulic Seed Controller Settings for Specific Planters



**NOTE!** The settings, provided below, should be a good starting point for control Look-Aheader settings. However, always take the time to calibrate the seed meters, check for proper seed placement in the field, and make system setting adjustments as needed. Do not rely solely upon the appearance of the On-Screen map. The on screen map will not show gaps and overlaps caused by incorrect GPS Offsets or AutoSwath Look-Ahead settings.

Planter brand	Control Valve Configuration	PWM Frequency	PWM Gain	Zero Flow Offset	Gear Ratio	Pulses/Rev.
John Deere Planters	PWM	175	110	40	2.374 (chain) 2.417 (ProShaft)	360
White Planters	PWM	200	90	30	5.5	360
Case IH Planters	PWM	100	90	40	6.803	360
Dickey-John Hydradrive	PWM	200	300	36	Need to Calculate	360
Kinze Mechanical Meter	PWM	200	130	33	1.533	360
Kinze EdgeVac Meter	PWM	200	60	45	2.947	360

### Hydraulic Seed Meter Calibration Numbers

Prior to calibrating the Hydraulic Seed Meter, the numbers that appear in the Meter Calibration box in the Planter Control window should be similar to the numbers that appear below. If they are not, the seed meter may be working incorrectly, or the Gear Ratio may be incorrect. Contact Technical Support for further assistance.



**NOTE!:** Check the operator's manual for more specific information on other seed disk options.

# Hydraulic Seed Rate Control

Planter brand and type	Corn	Soybeans	Cotton Standard Rate	Sorghum
John Deere				
Vacuum: Standard	30	108	64	45
Vacuum: ProMAX™	40			
Vacuum: Precision Planting eSet®	30			
Vacuum: VenHuizen AccuVac Kit	40			
Mechanical: Finger	12			
Mechanical: Brush Meter		56		

Case IH				
Vacuum	48	130	80	80
Cyclo®	36	240		

KINZE				
EdgeVac®	39	60	54	60
Mechanical: Finger	12	60	30	60

White				
	30	60		

Great Plains				
Mechanical: Standard	12	110	120	102
Mechanical: Twin Row	6	100		135

## Stepper Seed Rate Control

The Stepper Seed Control module allows Rawson ACCU-RATE Variable Rate Controller to control up to three hydraulic motor drives via the display. Configure the Stepper Seed Rate Control module in the following order.

1. **Enter Controller Settings**—Included the Max Meter Speed, Gear Ratio and Minimum Allowable Ground Speed. See [Controller Settings for Hydraulic Seed Rate Motor Drives on page 294](#).
2. **Prime the Stepper Seed Meter**—This fills the seed meter with seed to avoid skips. See [Priming Seed Rate Meters on page 306](#).
3. **Meter Calibration**
  - a. Enter Meter Calibration Number. This number, representing seeds per revolution, is set according to the number of seeds dropped per one revolution of the seed meter.
  - b. Perform a Seed Meter Calibration. A new calibration should be performed if the as-applied seed rate does not match the actual population planted. See [Calibrating Seed Rate Meters on page 306](#).

## Controller Settings for Stepper Seed Rate Motor Drives

Stepper Controller Settings should be set before entering a meter calibration number or performing field operations.

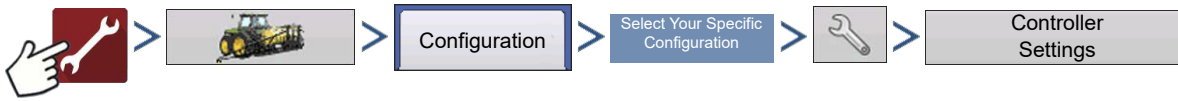

Each channel is displayed with its own tab. Auxiliary Tab allows adjustment of the Minimum Allowable Ground Speed.

### Channel Tabs

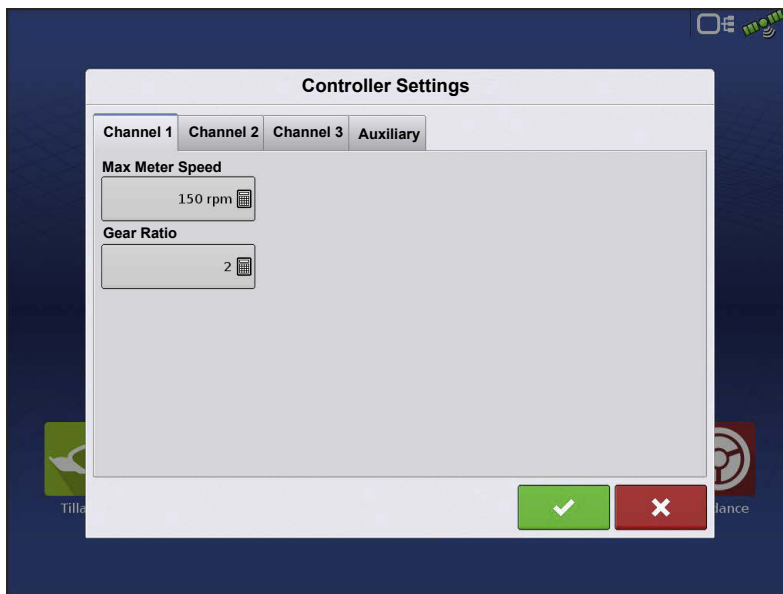

**Max Meter Speed**—This number represents the maximum recommended RPM of the seed meter, and is specified by the manufacturer. A warning appears if this threshold is exceeded.

**Gear Ratio**—The ratio of the revolutions of the hydraulic drive to turn the seed meter one revolution.

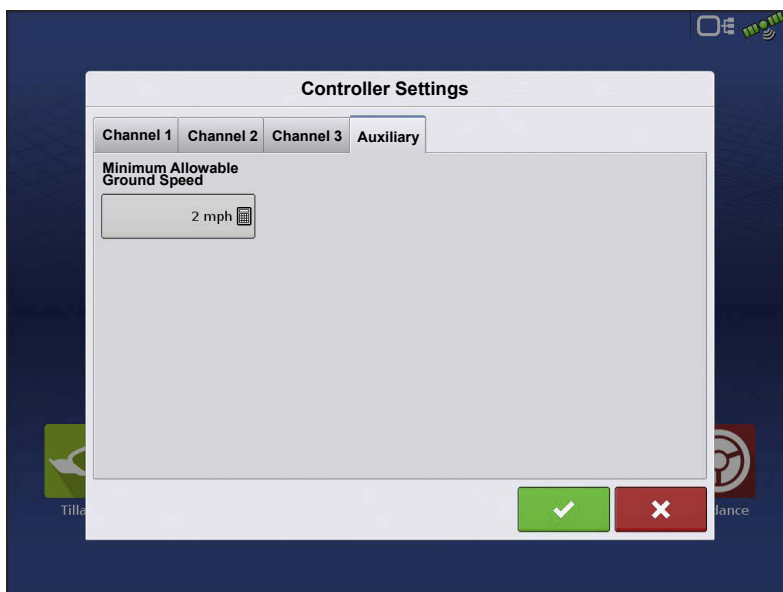

**Minimum Ground Speed**—The planter will plant at this simulated ground speed, until displayed ground speed is above this value. This fixed ground speed compensates for delays in acquiring an initial ground speed when starting from a stand still. Planting at the minimum ground speed will occur when either of the following conditions are met:



- a. Wheel motion is detected. Requires wheel motion sensor.
- b. Jump start switch is depressed. Required jump start switch kit

## Gear Ratio Calculations for Seed Rate Motors

The Gear Ratio is a setting that appears on the Controller Tab for the Stepper Seed Control Module and Hydraulic Seed Control Module. It is the ratio of the revolutions of the hydraulic drive as compared to one revolution of the seed meter. This setting is used to determine how fast the Seed Rate Motor should operate to achieve the proper RPM of the seed meter during planting operations.

To manually enter a Gear Ratio in the Controller Settings window, calculate the Gear Ratio based on information provided below and on the following pages. The Gear Ratio number is calculated by multiplying all the gear ratio combinations, from the Seed Rate Drive Motor to the Seed Meter.

### Seed Ratio Calculation Example Procedure

The example outlined below assumes a single planter drive motor.

1. Beginning with the Seed Rate Motor, count the number of teeth on the drive sprocket. Then count the number of teeth on the driven sprocket.
2. Divide the number of teeth on the driven sprocket by the number of teeth on the drive sprocket. This is the ratio of the Seed Rate motor.
3. Repeat the process for each sprocket combination in the drive system back to the meter.
4. Take the ratio of the Seed Rate Motor and multiply it by the ratio of the other sprocket combinations.
5. Repeat this process for multiple hydraulic drives. Enter the gear ratio for each motor under the appropriate tab.



**NOTE!** Enter the number into the other channels for additional motor drives if they have the same total gear ratio.



**NOTE!** Gear Ratio is the number of revolutions of the motor to turn the seed meter one revolution.

---

## Gear Ratio Drawing - For Single Motor Drive

Seed Rate Drive Setting (Calculating drive gear ratio)

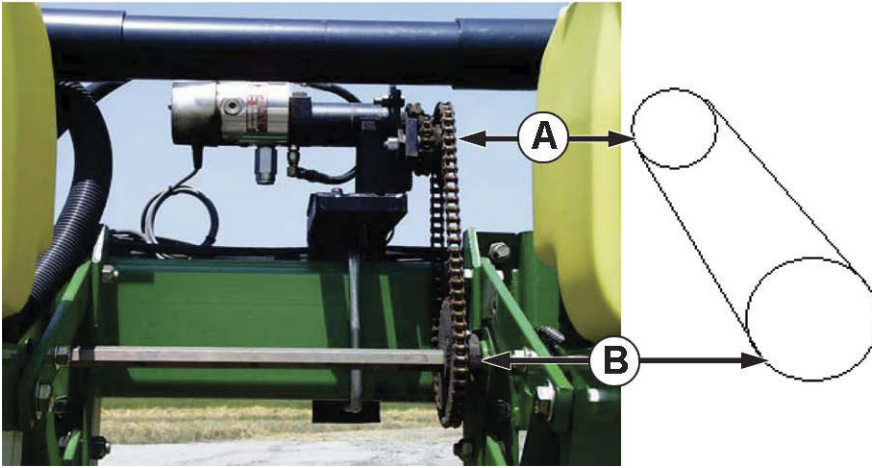

A. Seed Rate Motor (Drive) 18 Tooth Sprocket

B. Planter Drive Shaft Sprocket (Driven) 29 Tooth Sprocket

# of Teeth on the Driven Sprocket

$$\frac{\text{Ratio}}{\text{\# of Teeth on the Drive Sprocket}} = \text{Gear Ratio}$$

$$\frac{29}{18} = 1.611$$



**NOTE!:** Each drive combination (Driven/Drive) from Seed Rate Motor Drive to Seed Meter shaft sprocket needs to be factored for the Total Gear Ratio.

## Gear Ratio Drawing - For Multiple Drive Combinations

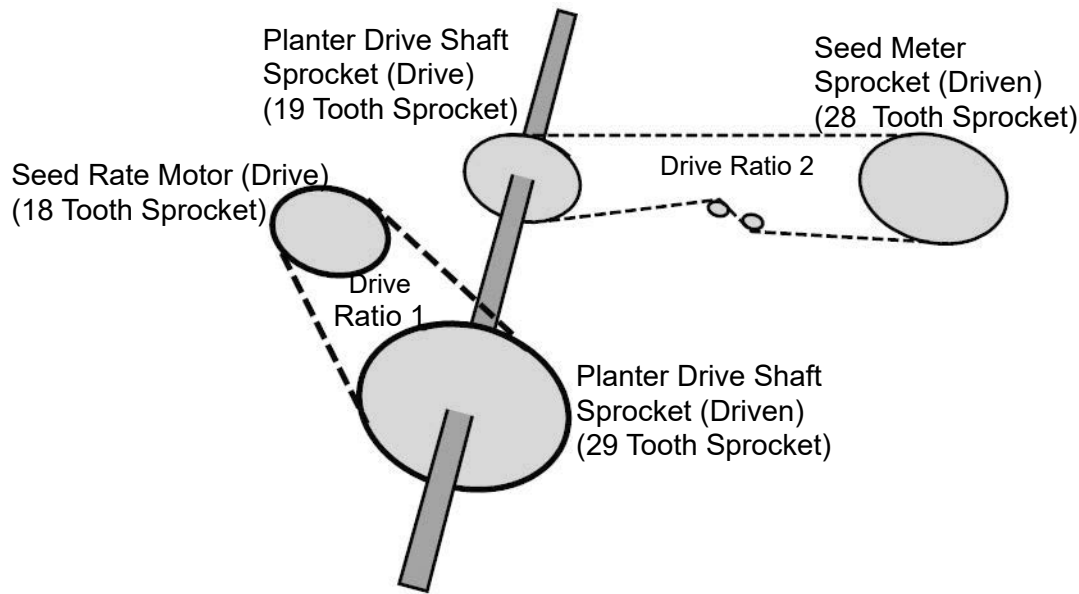

$$\frac{\text{Planter Drive Sprocket}}{\text{Seed Rate Motor}} \times \frac{\text{Seed Meter Shaft}}{\text{Planter Drive Shaft}} = \text{Gear Ratio}$$

$$\frac{29}{18} \times \frac{28}{19} = \frac{812}{342} = 2.374$$

Driven/Drive  $\times$  Driven/Drive = Gear Ratio

1                      2

Carry the Decimal place to the nearest 0.001 for accurate results.

### Seed Ratio Calculation Example Procedure for Shaft Drives

This example assumes a single drive motor. Step 5 notes that this process has multiple steps for more than one hydraulic drive.

1. Beginning with the Seed Rate Motor, count the number of teeth on the drive sprocket. Then count the number of teeth on the driven sprocket.
2. Divide the number of teeth on the driven sprocket by the number of teeth on the drive sprocket. This is the ratio of the Seed Rate motor.
3. Repeat the process for each sprocket combination in the drive system back to the meter.

4. Take the ratio of the Seed Rate Motor and multiply it by the ratio of the other sprocket combinations.
5. Repeat this process for multiple hydraulic drives. Enter gear ratio for each motor under the appropriate tab.

**i** **NOTE!:** Enter the number into the other channels for additional motor drives if they have the same total gear ratio.

Drive Ratios		
Planter Brand	Driven	Drive
Case IH Planters	2	2
John Deere Planters	3	2
White Planters	11	5

**i** **NOTE!:** These values are for the shaft only.  
 Drive/Driven value between the Seed Rate Motor and Planter Drive Sprocket must still be determined.

### Gear Ratio Drawing Shaft Drives

#### John Deere Planter Example

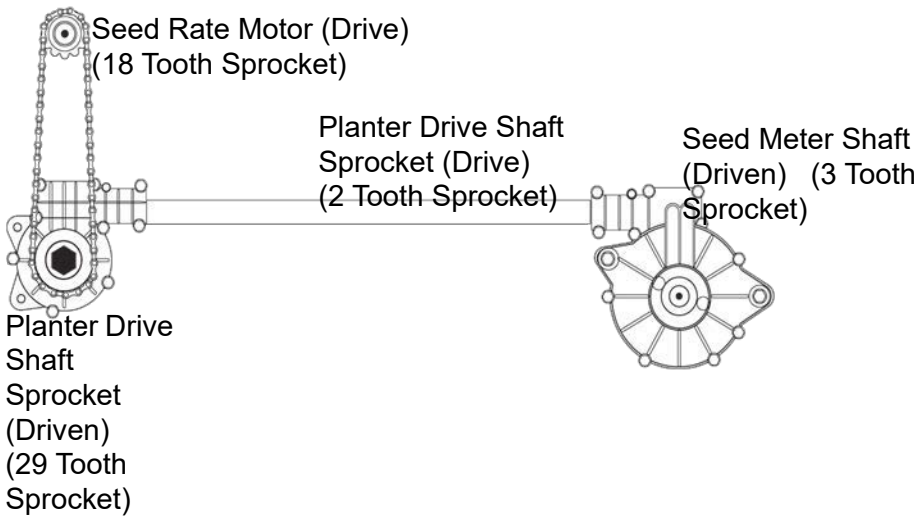

$$\frac{\text{Planter Drive Sprocket}}{\text{Seed Rate Motor}} \times \frac{\text{Seed Meter Shaft}}{\text{Planter Drive Shaft}} = \text{Gear Ratio}$$

$$\frac{29}{18} \times \frac{3}{2} = \frac{87}{36} = 2.417$$

Driven/Drive  $\times$  Driven/Drive = Gear Ratio

1                      2

Carry the Decimal place to the nearest 0.001 for accurate results.



**NOTE!:** If determining shaft ratios for any shaft not listed in the table above, rotate input shaft (driver) 10 times. Count how many times the output (driven) shaft turns. Divide the number of turns of the input shaft by the number of turns of the output shaft.

## Planter Options

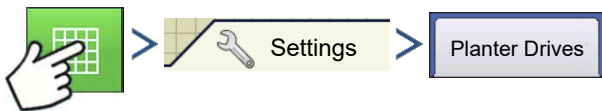

OR

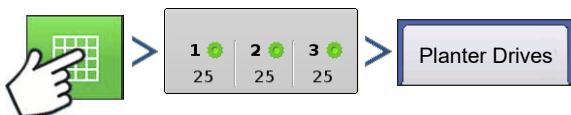

Represents the number of cells on a seed disk.

## Priming Seed Rate Meters

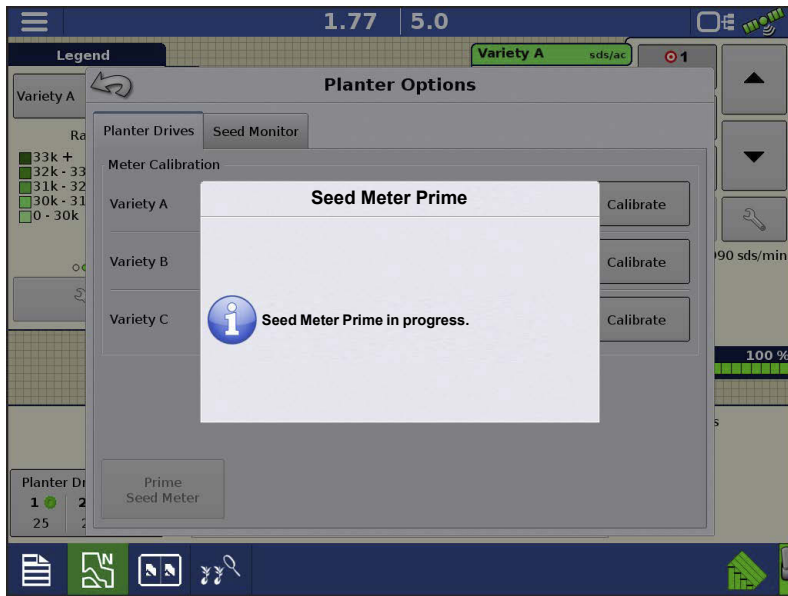

The Seed Meter Prime is used to charge the seed meter when filling with seed.

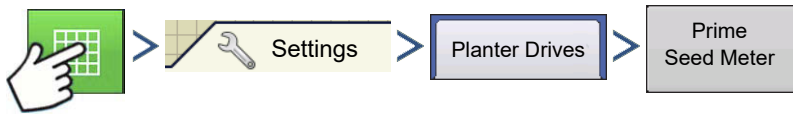

OR

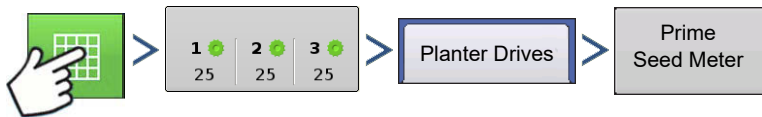

A message displays, stating "Seed Meter Prime in Progress." While this message displays, the seed meter will turn one (and only one) revolution automatically. When complete, return to the Planter Options screen.

## Calibrating Seed Rate Meters

The Meter Calibration number allows the seed meter to communicate the correct seed population to the display. Assuming the Controller Settings are correct for the seed rate, this Meter Calibration number, which is based on the number of cells on the seed disk should not need to be adjusted. However, you may wish to recalibrate after changing seed types and treatments. Recalibrate if the as-applied seed rate does not match the population shown on the planter monitor.



## NOTES!:

- The seed rate meter calibration does not recalibrate any previously-logged planting data.
- This recalibration number applies to a specific crop type, (for example: corn). Normally, there is no need to recalibrate when switching varieties within the same crop type.
- Make sure seed meter is primed before starting calibration.
- When catching dispensed seed during calibrations, it's advised to catch seed from multiple rows on the drive shaft in order to get a more accurate sample.



OR

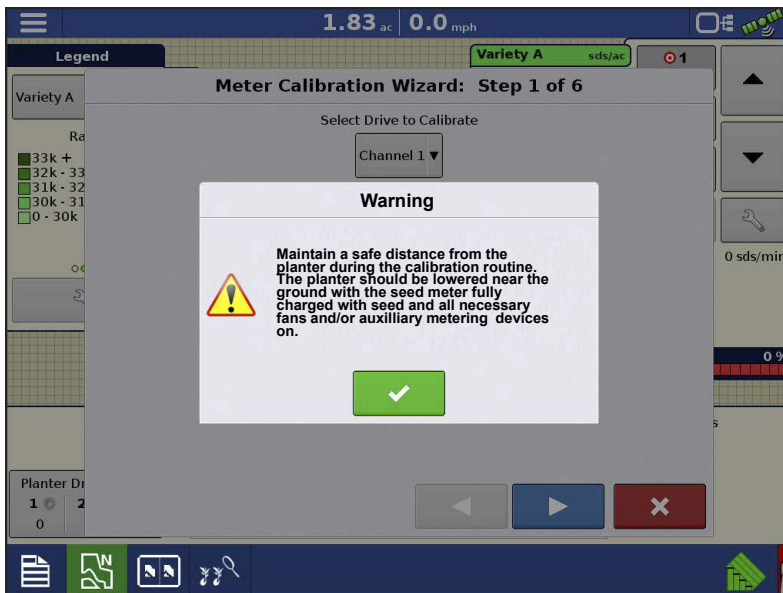
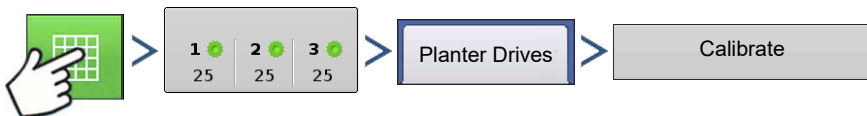

### 1. Acknowledge the Warning—

Acknowledge this warning by pressing



### 2. Select Drive to Calibrate—

The Meter Calibration Wizard appears.

Select the drive to calibrate. Press



to continue.

### 3. Enter Simulated Ground Speed—

Enter the simulated ground speed for the calibration procedure. Press

 to continue.

---



4. **Enter Simulated Target Rate**—Enter the simulated target rate of the calibration procedure.

Press  to continue.

5. **Press Start**—Press the green Start button to begin dispensing the seed.

6. **Dispensing Seed**—The seed meter turns for **five** revolutions. As the seed meter dispenses seed, the button will change its color to red, and a message displays that seed dispensing is in process.

7. **Seed Dispensing Complete**—When the meter is finished dispensing seed. Press  to continue.

8. **Enter Number of Dispensed Seeds**—Press  to enter the number of dispensed seeds. Press  to continue. The meter calibration will be calculated from the actual seed amount dispensed.

- If catching dispensed seed from multiple rows, total the overall dispensed seed and average that value based on the number of rows being caught. (Example: catching 4 rows; 610 total dispensed seed; value entered will be 152.5)



**NOTE!:** The value entered for dispensed seeds should ideally be very close to the number of cells on the seed disk multiplied by 5. If the new Meter Calibration (sds/rev) value differs by more than 1 or 2 of the original value, consider inspecting the Gear Ratio, Controller Settings, and/or overall meter performance. Contact Technical Support for further assistance.



---

## Troubleshooting

### Hydraulic Seed Control: Zero Flow Offset Variation

Zero Flow Offset is an operator-entered setting. Zero Flow Offset represents the maximum duty cycle that is sent to the control valve without producing any hydraulic flow from the PWM valve. Using too high of a Zero Flow Offset value can cause the product control system to not properly control low rates. Zero Flow Offset may vary somewhat by system and by operating conditions. On the tables on the following pages, problems and causes relating to Zero Flow Offset are listed. Use the Confirmation Techniques to determine if this is a problem; and then follow the appropriate solution.

**Problem:** Hydraulic drive is not shutting off properly

**Possible Cause:** Zero Flow Offset is set too high

**Confirmation Techniques:**

- a. Put the problematic drive in Manual Valve control from the Map screen.
  - Master switch will need to be On and Implement Switch triggered in order for the drive to turn
- b. Press the Up arrow once to start turning the drive, then press the Down arrow three times.
  - If the Zero Flow Offset is set appropriately, the drive will shut off on the third down button press.
- c. If the drive is still turning after the third Down button press, the Zero Flow Offset is too high.
- d. Decrease the Zero Flow Offset setting by increments of 1 or 2.
- e. Repeat the above steps until the drive stops turning on the third Down button press. The Zero Flow Offset will then be set once this is achieved.

**Problem:** Hydraulic drive is slow to begin turning

**Possible Cause:** Zero Flow Offset is set too low

**Confirmation Techniques:**

- a. Put the problematic drive in Manual Valve control from the Map screen.
  - Master switch will need to be On and Implement Switch triggered in order for the drive to turn
- b. Press the Up arrow once to start turning the drive, then press the Down arrow three times.

- 
- If the Zero Flow Offset is set appropriately, the drive will shut off on the third down button press.
- c. If the drive stops turning before the third Down button press, or doesn't start on the Up button press, the Zero Flow Offset is too low.
  - d. Increase the Zero Flow Offset setting by increments of 1 or 2.
  - e. Repeat the above steps until the drive stops turning on the third Down button press. The Zero Flow Offset will then be set once this is achieved.



**NOTE!** Zero Flow Offset should never be less than 25. If 25 still seems as if this number is too high, there must be some other problem. Contact Technical Support for further assistance.

## Stepper Seed Control Meter Alarms

**Error Message:** “Drive Out of Synch Error Drive #”

**Possible Cause:** Not enough hydraulic fluid is flowing to the seed meter.

**Solution:** Examine the stepper seed drive's hydraulic components for restrictions. Make sure the tractor's hydraulic outlet is turned on. Make sure the hydraulic flow settings are correct.

**Error Message:** “Drive Stalled Drive #”

**Possible Cause:** The hydraulic drive motor has stopped rotating.

**Solution:** Check the stepper seed motor to see if it is restricted from turning, and that the hydraulic drive is working.

**Error Message:** “Meter Not Moving - Drive #”

**Possible Cause:** Either the Seed Meter Calibration failed, or the Seed Meter Prime failed

**Solution:** Make sure that the tractor's hydraulic outlet is turned on.

**Error Message:** “Seed Drive at Maximum RPM Drive #”

**Possible Cause:** Starting the priming routine when the hydraulic motor is not on

**Solution:** Slow the planter unit's ground speed. - Reduce the Planting Target Rate.

ISOBUS Hydraulic Down Force

At a Glance—Universal Terminal

Planter Average Run Screen

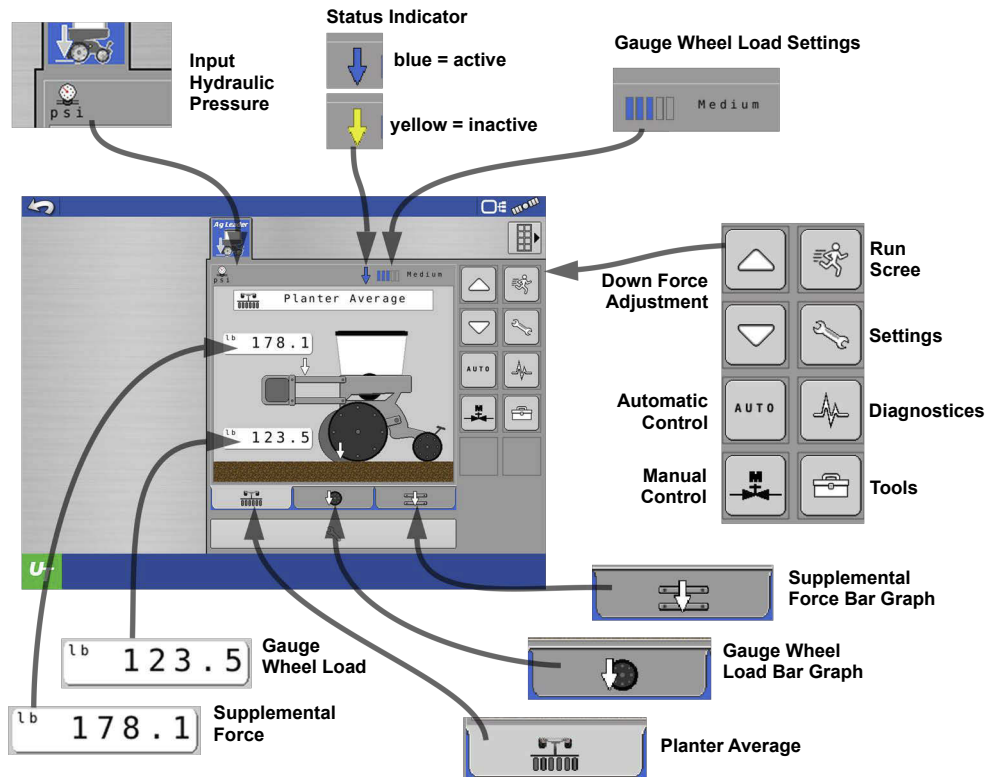

Gauge Wheel Load Bar Graph

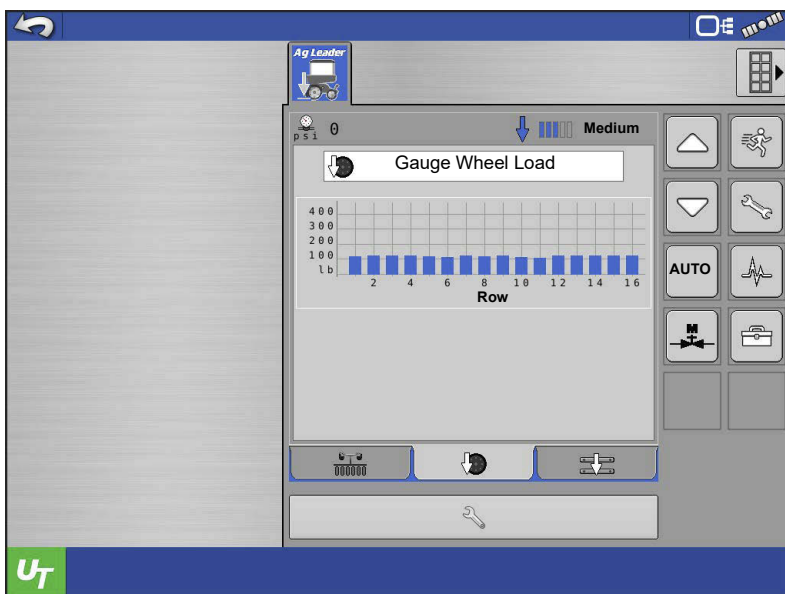

# Supplemental Force Bar Graph

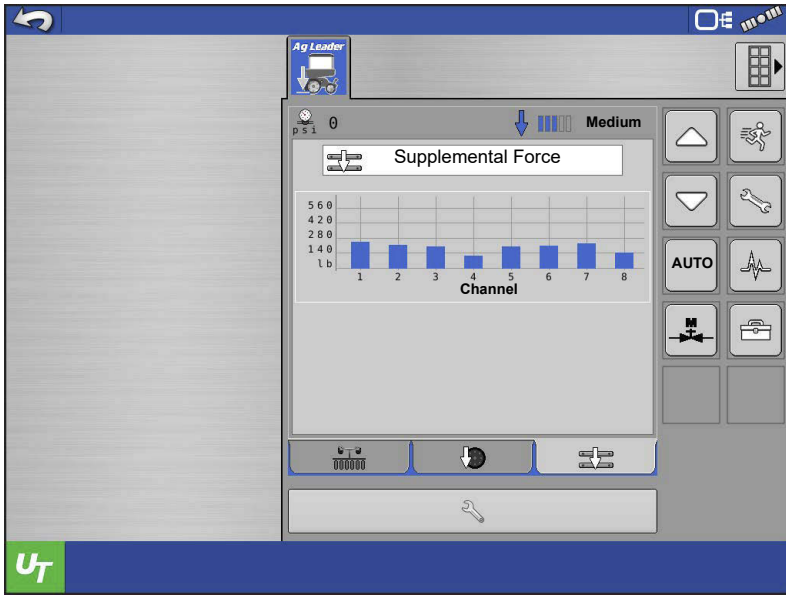

## At a Glance – With Ag Leader InCommand™ 1200

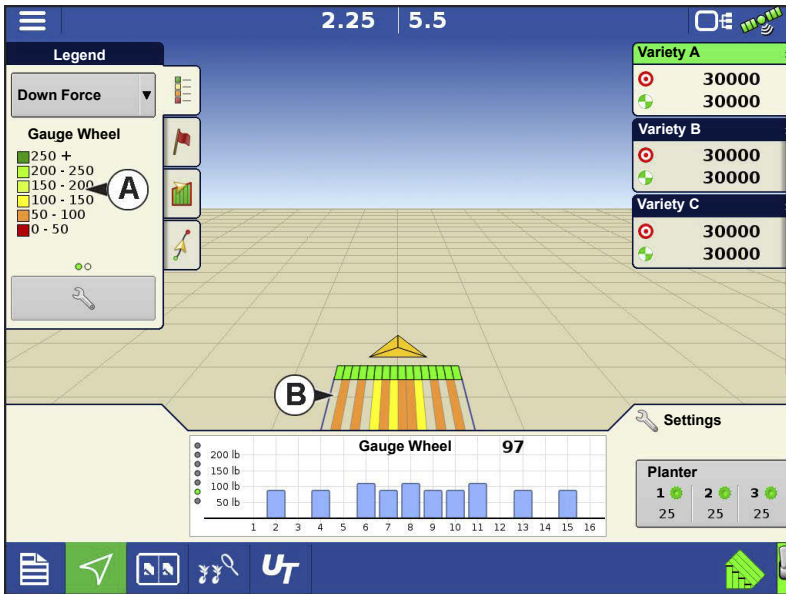

### Gauge Wheel Load Map

(A) Gauge Wheel Load Legend

(B) Mapped Gauge Wheel Load

**NOTE!** Planter rows that do not have a gauge wheel sensor installed will not map or log gauge wheel load for that row.

## Supplemental Down Force Map

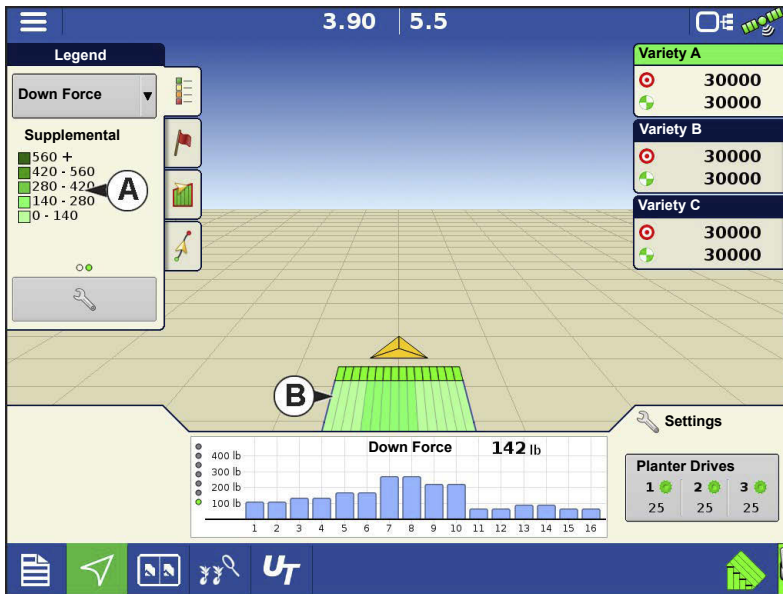

(A) Supplemental Down Force

Legend

(B) Mapped Supplemental Down Force

**NOTE!** Mapped Supplemental Force will reflect the ISOBUS Down Force configuration setup.

## Bar Graph

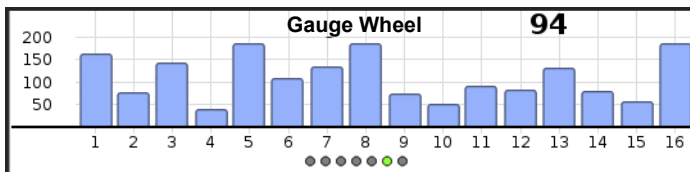

Tapping subsequently will toggle the bar graph between the following graphs. (Seed placement performance graphs will also

appear if a seed/planter monitor module is installed)

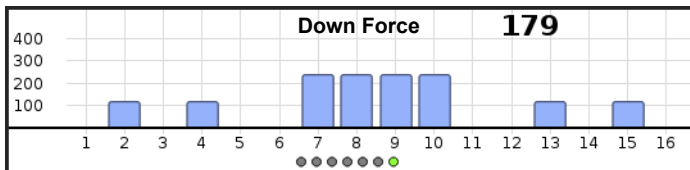

Supplemental Down Force and Gauge Wheel Load graphs are available in the Advanced Seed Monitoring screen. (This

screen will only be available when an Ag Leader Seed Tube Monitoring Module or Row Control Modules are installed).

# ISOBUS Down Force Configuration

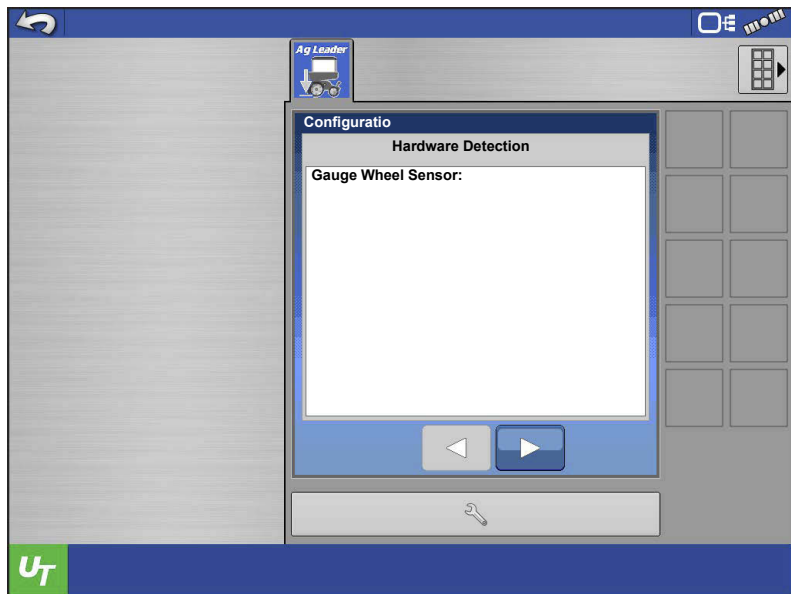

1. System automatically detects number of Gauge Wheel Sensors.



**NOTE!:** Module detection can take up to 30 seconds. If the number of detected row unit modules does not match what is installed, click the next arrow and then back again. If after 30 seconds have passed and the number of detected row unit modules does not match the number installed, check the

LED status of each Row Unit Module (RUM). LED will blink green when connected and communicating properly.

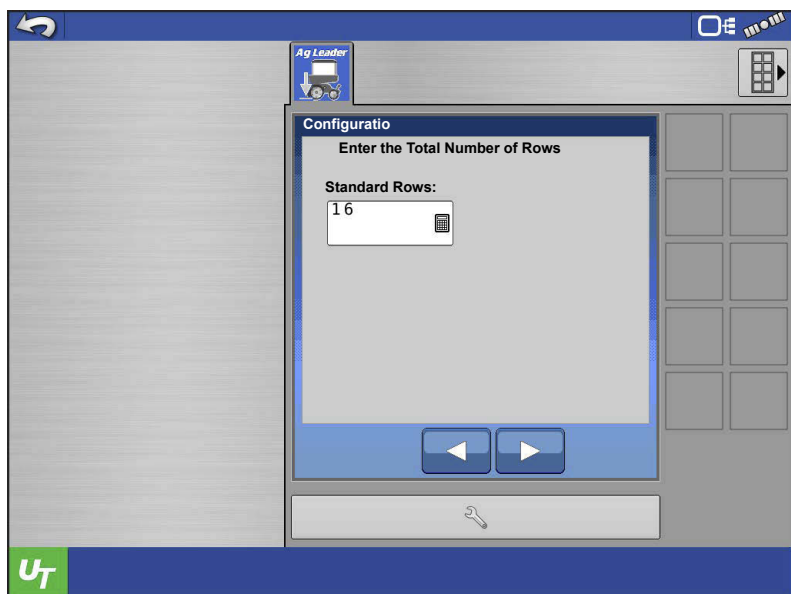

2. Enter the number of standard row units.

# ISOBUS Hydraulic Down Force

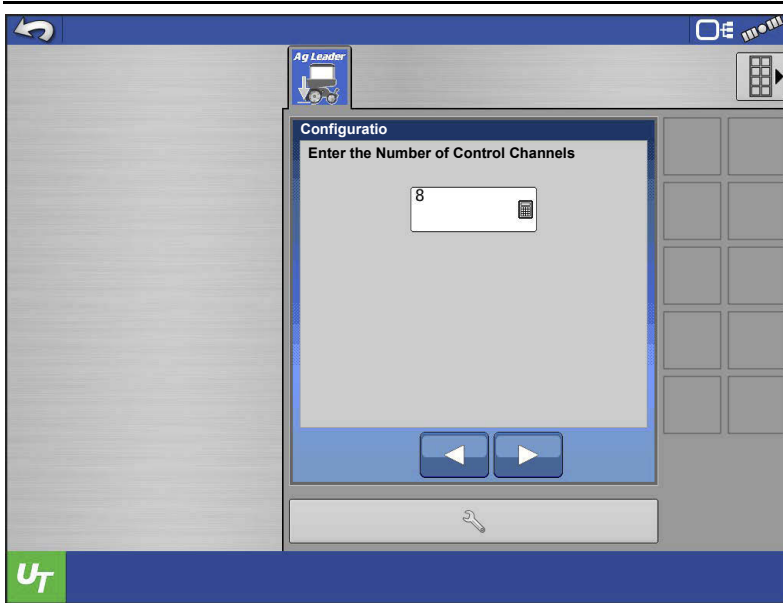

3. Enter the number of control channels. This will be equivalent to the number of valve sections. Typically this will range from 3 to 8 total sections.



**NOTE!:** Each section must contain at least 1 gauge wheel sensor.

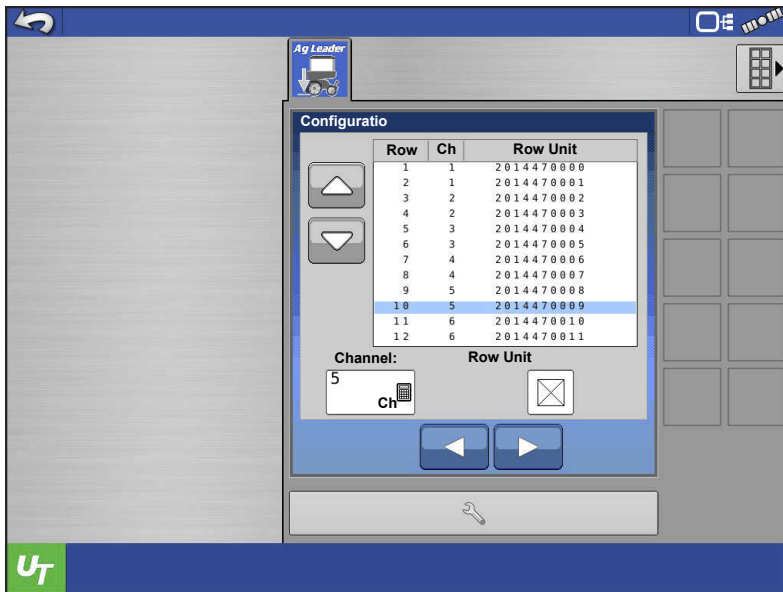

## 4. Row Unit Module (RUM)

Assignment:

a. Each gauge wheel sensor must be assigned to a specific row. Assign a sensor to each row that has a sensor installed. The "Row Unit" column will contain a number once a sensor has been assigned. This is the serial number of the Row Unit Module (RUM)



**WARNING!:** Verify the serial number of each assignment RUM with the serial number printed on the RUM.

If these do not match, this indicates improperly connected wires.

b. Each row of the planter can be assigned to a specific control channel. The selected control channel **MUST** coincide with hydraulic hose connection to the valve.



**WARNING!:** Failure to assign the correct control channel as dictated by the hydraulic hose connection to the valve will cause poor planting performance.

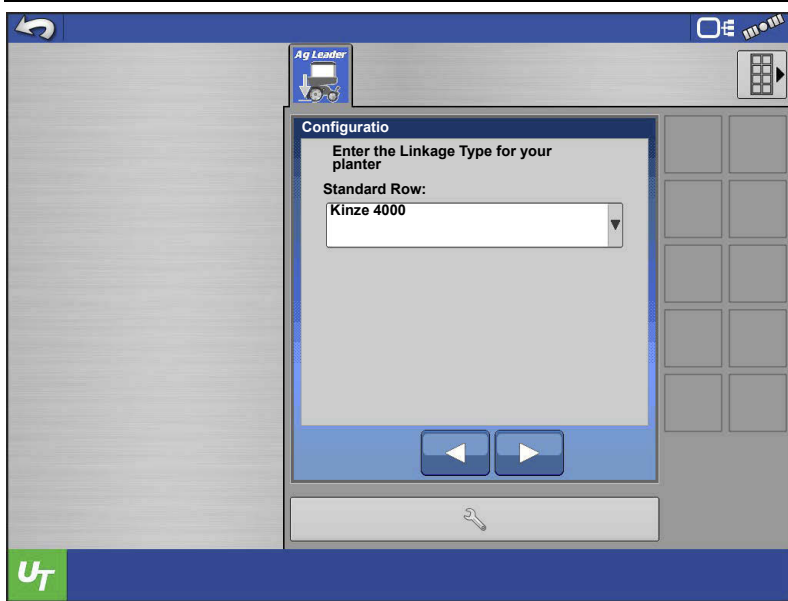

5. Enter the linkage type for your planter. Use the drop down menu to select the type of parallel arm your planter is equipped with.

**i NOTE!:** John Deere Short parallel arms have an overall length of 15-3/4". John Deere Long parallel arms have an overall length of 23".

**i NOTE!:** Planters may have a

combination of short and long parallel arms. Linkage type can be selected independently for each channel, as explained in next step.

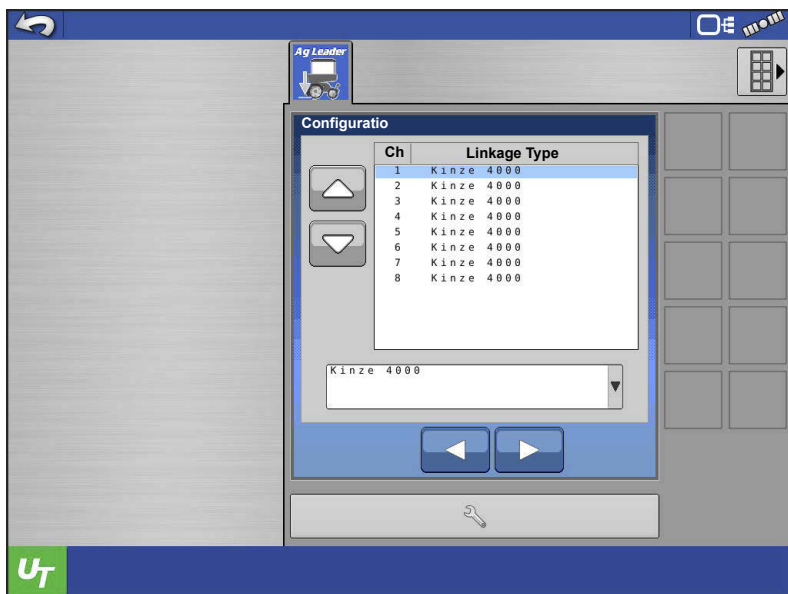

6. Select the linkage type for each channel. In most cases the planter will have only one type of linkage. If the planter has multiple linkage types, select the type of linkage for each channel.

- Each Channel may only be configured for 1 type of linkage.

- If it is not possible to divide sections so each section contains only one type of linkage, sections configured with

more than 1 type of linkage may cause poor planting performance.



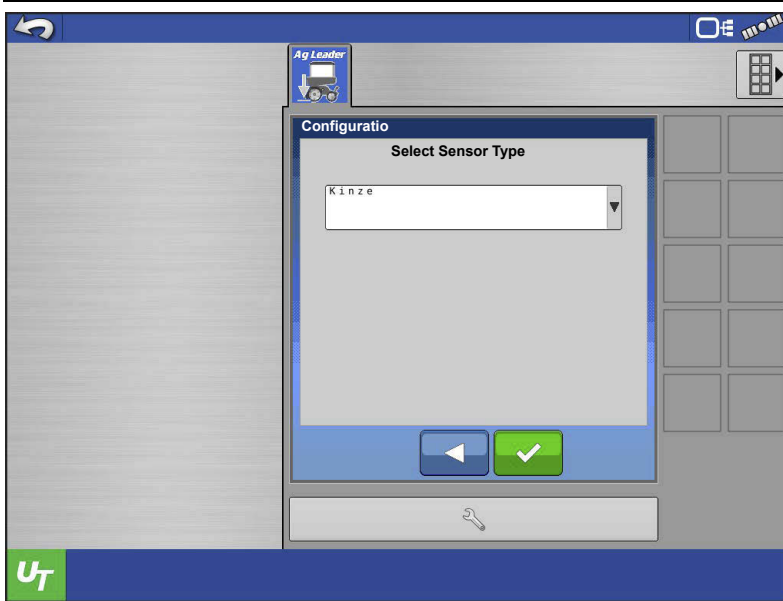

7. Select the type of gauge wheel sensor that is installed. The sensors are identified by the planter manufacturer and part number printed on the sensor or the label near the sensor connector.



**WARNING!** Selecting the incorrect sensor type will cause poor planting performance.



**NOTE!** The entire planter must

have only 1 type of sensor installed.



**NOTE!** John Deere planters have 2 different sensor part numbers that could be installed. Be sure to select version in the drop-down menu matches the version installed on the planter.

8. Configuration is complete. Once completed, the module will reboot itself. This will cause a lost communication alarm.

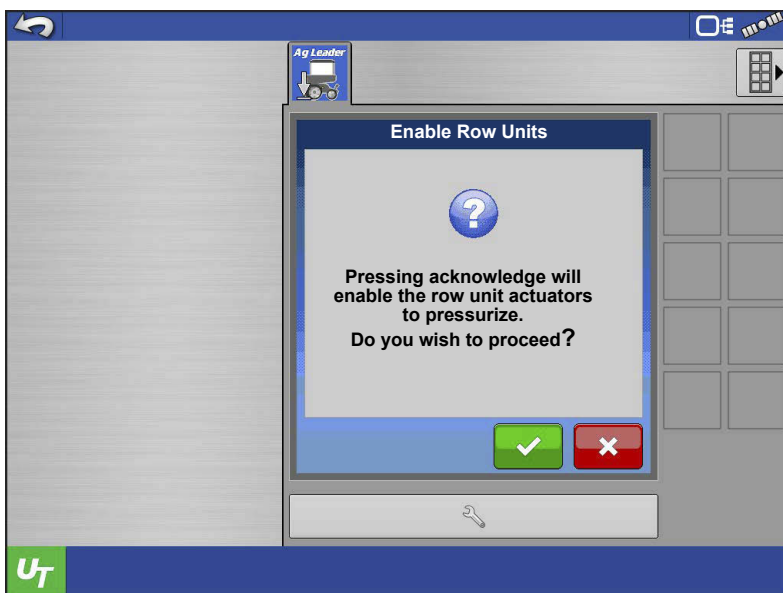

9. When the module has rebooted, the user will need to accept the disclaimer message to enable the row units for control. This message will need to be accepted each time the display is powered on.

# ISOBUS Down Force Operation

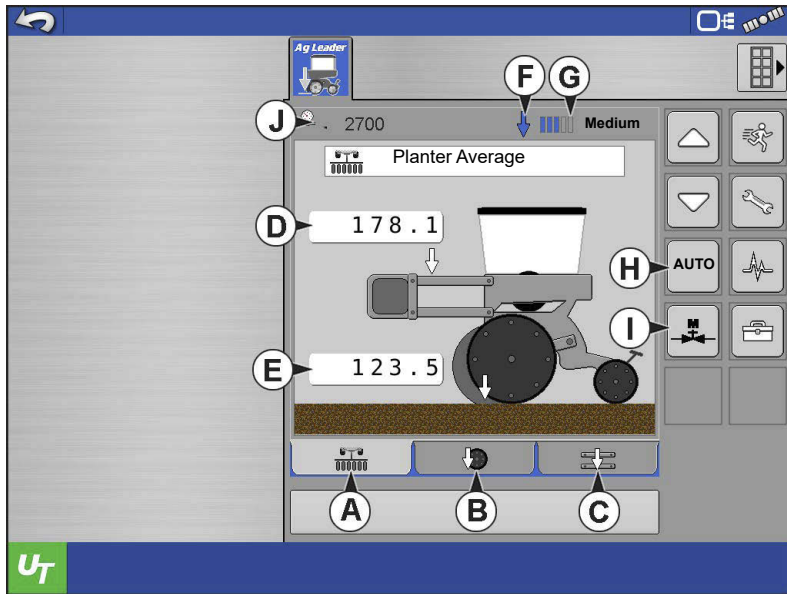

1. User can choose to display 1 of 3 interface modes.

a. Planter Average

- Displays average supplemental down force.

b. Gauge Wheel Load

- Displays average gauge wheel load
- Displays gauge wheel load of each row that has a sensor installed

c. Supplemental Force

- Displays supplemental down force

being applied to each section

d. Supplement Force

e. Gauge Wheel Load

f. Blue Arrow—Control is Active

Yellow Arrow—Control is Inactive, or Holding down force



**NOTE!** The indicator arrow will only go blue (Active down force control) when the implement switch is triggered to the Down position, and if an available speed source is over 0.5 mph (0.8 Km/h). Refer to [Speed Source](#) on [page 344](#) for further detail.

g. Gauge Wheel Setting—Automatic Mode

h. Automatic Control

i. Manual Control

j. Input Hydraulic Pressure

2. When in **Automatic Mode**, user can select 1 of 5 available gauge wheel load settings. Each available setting is an offset to the continuously calculated target gauge wheel load. Target Gauge Wheel Load is defined as: The amount of gauge wheel load necessary to achieve proper depth 100% of the time, while minimizing compaction as much as possible (without risking loss of proper planting depth).

Gauge Wheel Load Settings	Offset to Target Load
Minimum	-100 lbs (-45 kg)
Light	-50 lbs (-23 kg)
Medium	No offset
Heavy	+50 lbs (+23 kgs)
Maximum	+100 lbs (+45 kgs)

Example: Based on the ground conditions in a specific area of a field, the down force system applies 150 lbs of supplemental force in order to achieve a target gauge wheel load of 100 lbs. However, if the Gauge Wheel Load setting is set to **Heavy**, the target gauge wheel load is now 150 lbs. The supplemental force will adjust accordingly in order to achieve the new target gauge wheel load. (Keep in mind, the target gauge wheel load is a continuously calculated value)



**WARNING!:** When operating on light or minimum, shallow planting can occur.

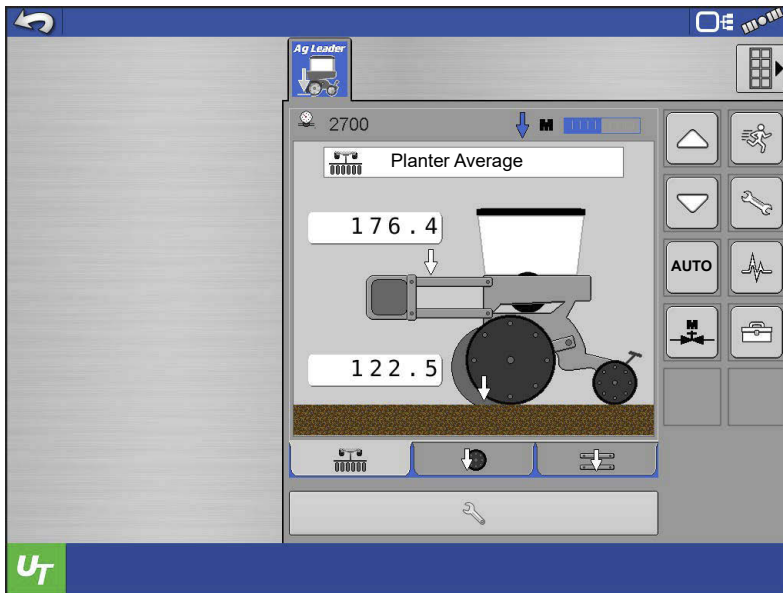

3. When in **Manual Mode**, user can select a supplemental down force by using the up and down arrows. Adjustments made in Manual Mode affect the entire planter. This cannot be set per channel.

# ISOBUS Down Force Settings

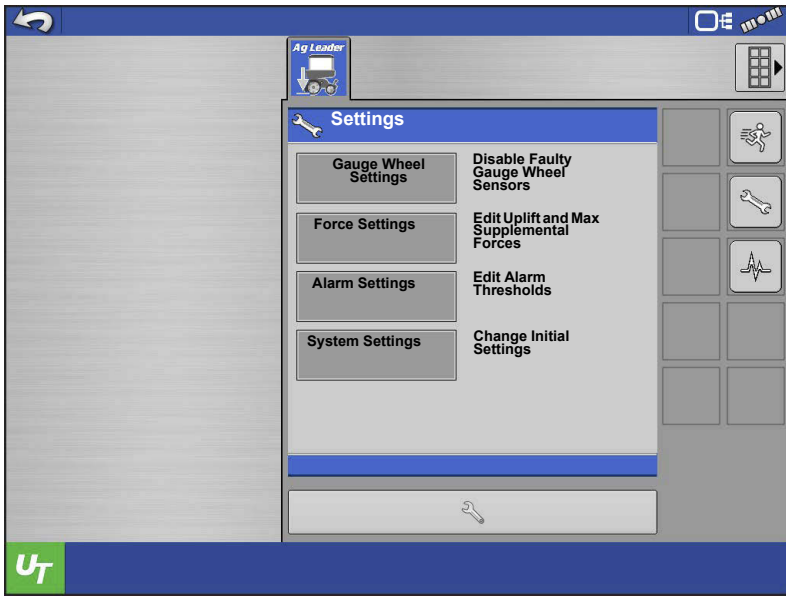

- Gauge Wheel Settings
- Force Settings
- Alarm Settings
- System Settings

## Gauge Wheel Settings

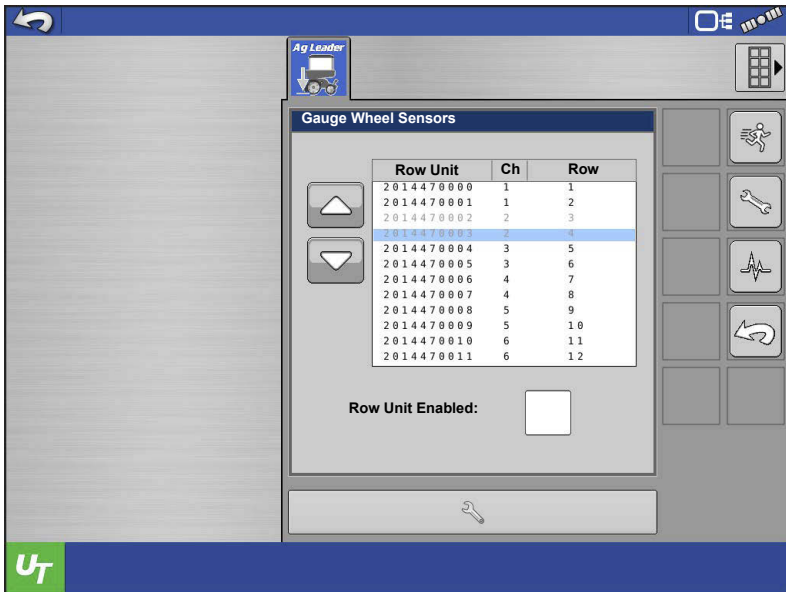

Failed Sensors can be disabled  
 If all sensors on an individual channel are disabled, the user may enter a **Disabled Channel Override** force for that channel, while allowing all remaining channels to continue functioning in automatic control mode.

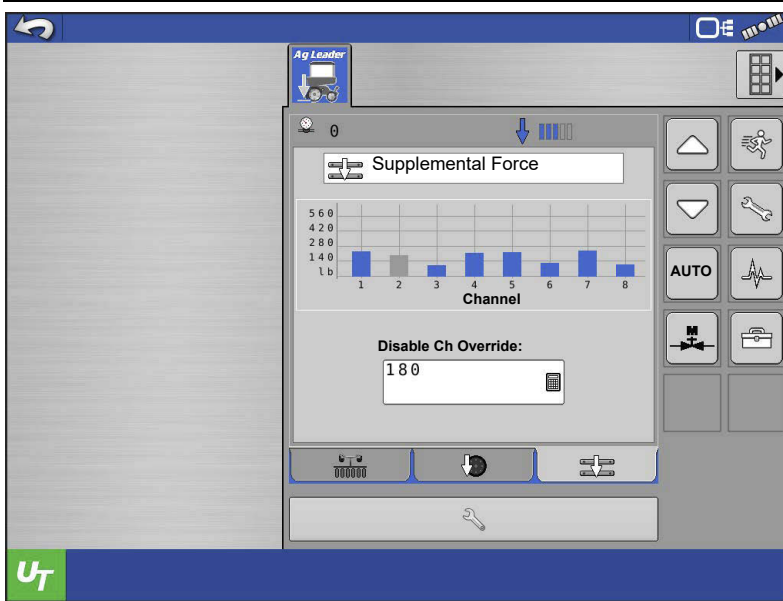

**i** **NOTE!:** A Disabled Channel Override only appears on this screen when all sensors for a channel are disabled.

## Force Settings

Set uplift force for each channel if optional uplift springs are installed

**Uplift Force**—usually 0 unless planter is equipped with uplift springs to provide an upward force on row units.

Uplift Force	
Parallel Linkage	Uplift Force
Deere Short Arm	140 lbs
Deere Long Arm	
4 spring design	160 lbs
2 spring design	100 lbs
Kinze 3000	140 lbs
Kinze 4000	130 lbs
White 8000/9000	100 lbs

**Set a Maximum allowable Force**—The system will not apply a force higher than this setting.

**i** **NOTE!:** When an uplift force amount is entered the actual Maximum Allowable Force that can be applied is now increased by that amount, in order to accommodate for the uplift. This takes place internally in the control module and is not displayed to the operator. Operators should enter Force Settings as they normally would.

## Alarm Settings

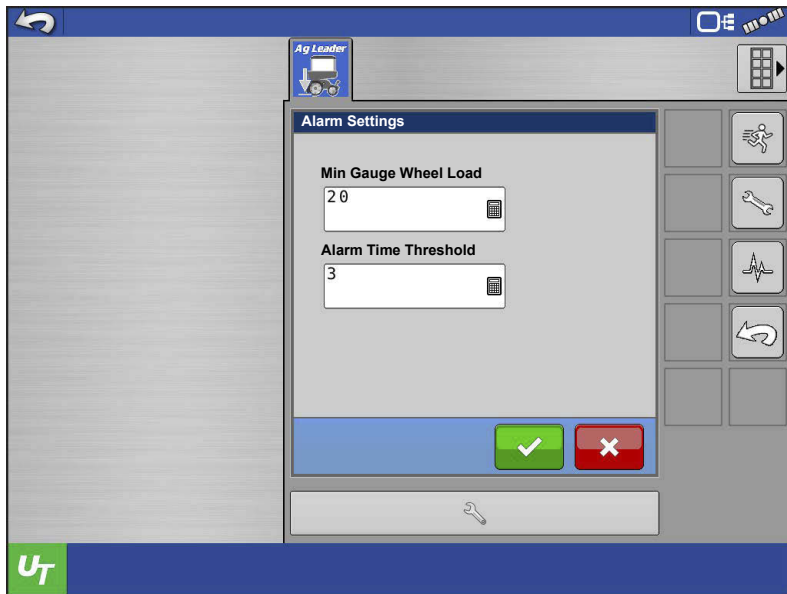

User will receive a “Low Gauge Wheel Load” alarm when load is below the selected gauge wheel load for duration of time set by the user.

## System Settings

**Reconfigure**—Configuration wizard that was used the first time the planter was set up for ISOBUS hydraulic down force.

**Reset**—Restore factory defaults to module. After doing so, a new configuration must also be made.

## ISOBUS Down Force Diagnostics

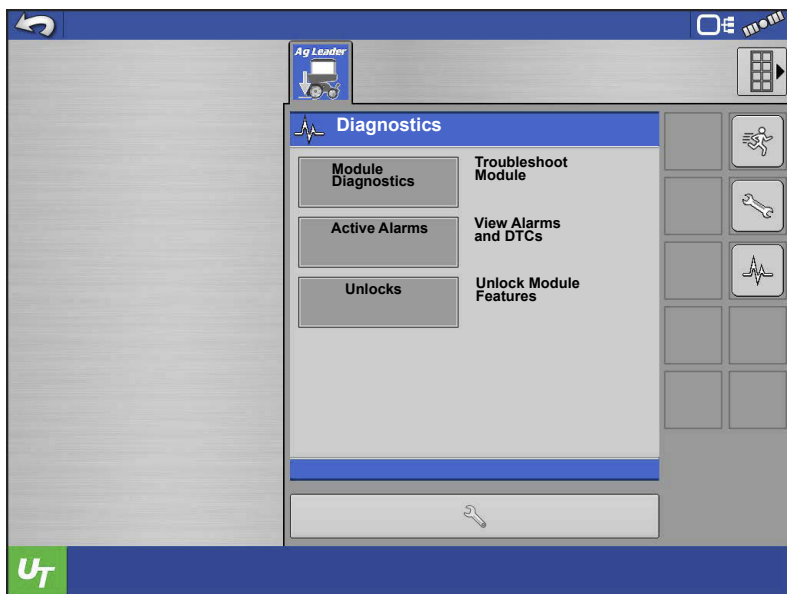

### 1. Module Diagnostics

-View control module firmware

-View individual sensor gauge wheel load

-View implement switch state (Up or Down)

## 2. Active Alarms

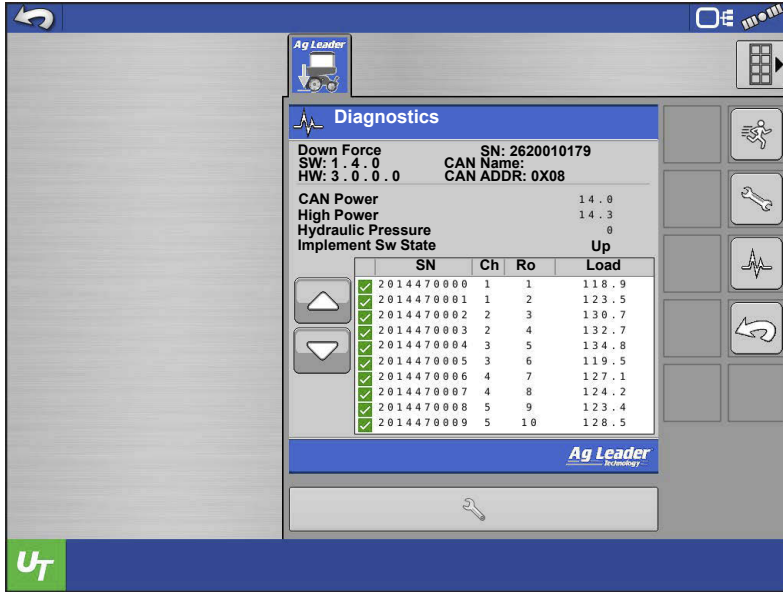

-Display currently active alarms

## 3. Unlocks

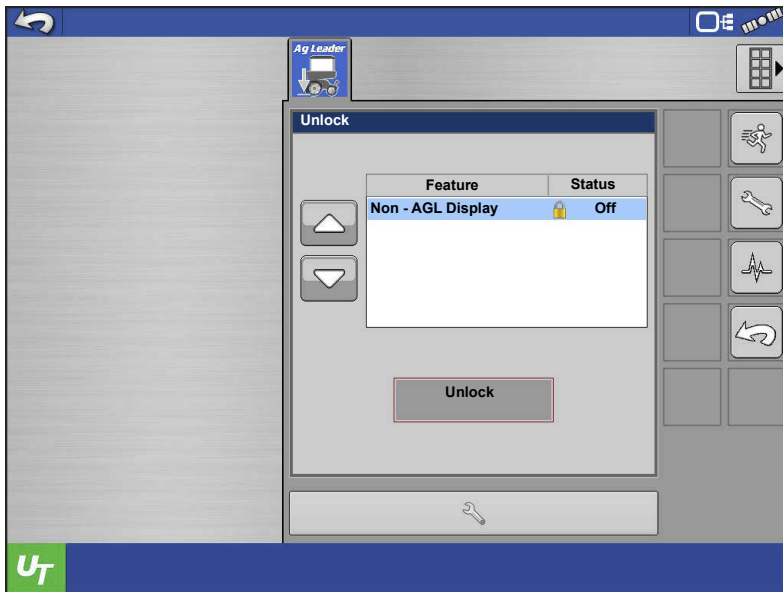

Enter Unlock code to allow use with non-Ag Leader ISOBUS universal terminal display.

## ISOBUS Down Force Tools

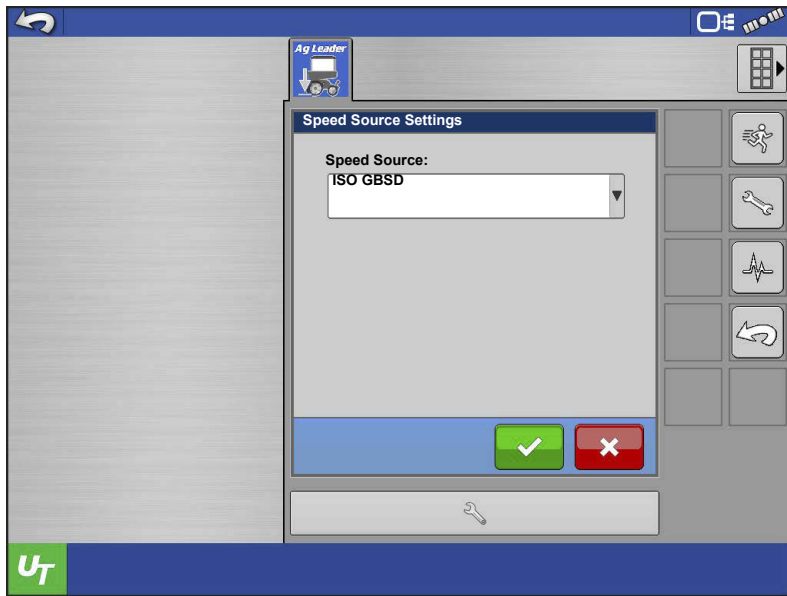

### 1. Speed Source

Select from the available speed sources. When a speed source is available and selected, the system will not actively control down force at speeds slower than 0.5 mph (0.8 Km/h). The down force will hold below this speed.

- a. CAN GPS (NMEA 2000)
- b. ISO GBSD (Ground Based Speed and Distance)
- c. No Speed Input—system is allowed to control planter anytime it is lowered with no minimum speed requirement.

### 2. Enable Automatic Control

Uncheck this box to enter monitor only mode.

## Down Force Alarms

### Down Force Inadequate

System hydraulic pressure is at maximum pressure, but the Down Force system is not achieving acceptable gauge wheel load.

**Recommendation**—If supplemental force is at maximum, increase Maximum Force on the Down Force setup screen.

- Planter may not weigh enough to handle field conditions - toolbar may be lifting. Verify if the toolbar is lifting by checking parallel arms while planting. If weight needs to be added to the toolbar, contact planter dealer.

### Low Gauge Wheel Load

Down force system does not achieve acceptable gauge wheel load

User defined alarm to signal operator if planter is losing planting depth.

### Hydraulic Pressure too low

Down force system commanding more down force but hydraulics are not reacting

### Recommendations:



- Check tractor remote is on
- Check that enough hydraulic fluid is directed to down force system

## Pressure Sensor Failure

**Problem**—Pressure sensor is outside voltage range.

**Resolution**—Disable pressure sensor until a replacement is available.

## Row Module Communication Lost

**Problem**—Row module communication lost.

**Resolution**—Inspect cabling of row module. Replace row module.

## Loadpin not detected

**Problem**—Row module is not sensing inputs. Row module is power cycling at intervals of less than 2 seconds

**Resolution**—Swap module with different row. If problem follows, replace module. If problem exists on same row, inspect or replace load sensor.

## How to use Manual Override



Manual Override of the control valve may be needed if all electronic control of the Down Force System is lost, or the operating display becomes unusable. Manual Override allows the Down Force system to apply a constant force in order to achieve planting depth (similar to down force springs). If the need arises to put the control valve into Manual Override, follow these steps.

Steps:

1. Engage hydraulics for the Down Force system.
2. Locate the Down Force control valve. Unplug the 2-pin connection that's plugged into the problematic channel(s). (Connections are plugged into each channels PWM valve).
3. Locate the allen head adjustments (3/16 inch) just below electronic PWM valve.



**ATTENTION!:** For the next step you will need a quick connect pressure gauge to measure the pressure being sent to each channel. (Ag Leader Hydraulic Test Gauge Kit PN 4100164).

4. Connect pressure gauge to the quick connect port on the back of the valve block. Port will be located under each control channel's 3/8" hose.



5. Screw the allen head adjustment IN to increase pressure sent to actuators; screw OUT to decrease pressure.

Pressure (PSI) sent to actuators is shown on the pressure gauge.

6. Refer to the table below and note the Hydraulic Pressure to Down Force Conversion ratio. Multiply this value by the desired down force; this will give you the appropriate pressure to adjust the valve to.

Parallel Linkage Pressure	Conversion Ratio
Deere Short Arm	4.5 psi/lb
Deere Long Arm	3.8 psi/lb
Kinze 3000	4.2 psi/lb
Kinze 4000	5.1 psi/lb
White 8000/9000	4.8 psi/lb

Example: Kinze 3000 planter = 4.2 PSI/lb. The desired down force is 250 lbs.

$$4.2 \text{ PSI/lb} \times 250 \text{ lbs} = \mathbf{1050 \text{ PSI}}$$



**WARNING!:** When in Automatic control, the allen head adjustment needs to be screwed all the OUT. Any pressure being sent through via Manual Override will be added to the pressure being sent by the PWM control, and will result in excessive down force being applied.

## FAQ

-What should my input hydraulic pressure (PSI) be set at?

2500 to 3000 PSI (with the vehicle hydraulic source set to max flow)

-Where do I plug in an implement switch(s)?

Into the Implement Switch Module(s).

-What if I don't have any free SCV connections for the down force valve?

Teeing into existing lines is acceptable. Do not tee into the vacuum fan line if adjusting fan RPM on the tractor with a knob or dial. Teeing into the line before a flow limiter on the planter would be acceptable. Teeing into the hydraulic drive supply line would be the best option. Do not tee into Rawson Drive supply line.

-What if my hydraulic oil gets too hot?

Ag Leader sells a Load Sense kit (P/N 4101225) to help manage oil temperatures.



**NOTE!:** This system will not help if using SCV to control hydraulic drives. In this case, an auxiliary oil cooler may need to be installed.

-What if my hydraulic actuator does not extend far enough to reach the lower bracket with row unit at bottom travel?

Purchase one spacer kit (P/N 4101201) per row. This will install at the bottom of the ram. (Commonly used on John Deere long parallel arms)

-My Kinze 3000 planter has rows that are offset 4" back, causing the upper actuator bracket to not line up with the lower actuator bracket.

Purchase one spacer kit (P/N 4101204) per row. This will move the upper bracket 4" rearward.

-Why is the gauge wheel load bar graph constantly spiking and then going to 0?

This can happen if control channel lines are routed incorrectly. Ensure channel components (hydraulic hoses, control valve cable, gauge wheel sensor wiring) are installed per the instructions.

-Why does the system need 3 hydraulic lines (Pressure, Return and Tank)

Under normal operation, pressure in the down force system is increased through the Pressure line and relieved through the Return line. When the planter runs over a terrace or a water way, the excess pressure is released through the Tank line. All three lines MUST be connected.

---

-What happens if my Pressure and Return hoses are connected backwards on my Hydraulic Down Force valve block?

If the Pressure and Return hoses are connected backwards on the Hydraulic Down Force valve block, the hydraulic flow will be sent directly to the channels connected to the valve block. Once this happens, the actuators on all of the channels will be applying max supplemental force. On the screen of the controlling display, this may likely result in very high gauge wheel load. This will occur on all variations of valve blocks that Ag Leader supports.

-What is a CAN Repeater Module; and when is it required?

A CAN Repeater Module is a component that is used on Ag Leaders ISOBUS Hydraulic Down Force system. It is only installed on systems with a Local CANBUS that exceeds a certain length. The modules purpose is to “repeat” CAN messages on these longer BUS lines to ensure communication between all of the modules connected. Ag Leader will supply the CAN Repeater Module in appropriate kits as needed.

-Can an open-center tractor be used for Ag Leaders Hydraulic Down Force?

Open-center tractors are not recommended for use with Ag Leaders Hydraulic Down Force.

## Troubleshooting

**Problem:** - Down Force will not adjust in Auto Control while planting (Down Force Holds)

- Down Force indicator arrow stays Yellow while planting.

**Solution A:**

- Verify implement switch(s) polarity is correct.
  - Verify implement switch(s) are tripping when planter is lowered.
1. With planter lowered, verify implement switch(s) have tripped.
  2. Check the polarity of the implement switch is correct. Implement switches can be swapped from Normally Open to Normally Closed by switching 3-pin weatherpack connections.
  3. On the Implement Switch module verify the indicator light turns blue on the module when the switch is tripped.
  4. Check mounting of implement switch(s).
  5. While operating Down Force, verify the toolbar is not lifting causing the implement switch to trip.

**Solution B:** Check the Speed Source setting.

1. If CAN GPS or ISO GBSD is selected, those appropriate speed messages will need to be present on the ISOBUS for the Down Force to operate. These speed message will likely be available from the controlling display or GPS antenna.
2. If an Ag Leader display is being used, verify the "Broadcast Display Speed (ISO GBSD)" setting is checked in the ISOBUS Settings. Refer to the Display User Guide.

Ag Leader displays do not utilize the CAN GPS (NMEA 2000) speed message. Other third party displays may utilize this message.

**Problem:** Supplemental Force and Gauge Wheel Load do not appear to reflect each other's responses. (Ex: High Gauge Wheel Load on Channel 1, with very little Supplemental Force being applied, or vice versa)

**Solution:** Verify installation of the Local CAN terminators.

1. The Local CAN is the communication wiring bus that transfers the gauge wheel load readings to the main control module. There needs to be a terminator on each end of this bus.
2. Terminator PN 4002870 will need to be installed on the wiring harness closest to row 1. Terminator 4002871 will need to be installed on the wiring harness closest to the end of the planter (right-hand side when looking at planter from the rear).

**Problem:** Number of detected Row Unit Modules does not match the number of modules actually installed on the planter.

**Solution:** Verify installation of the Local CAN BUS. Proceed with the troubleshooting steps below.

1. Verify the Local CAN terminators are installed correctly.
  - a. PN: 4002870 must be installed on the left-hand side of the planter (closest to planter row 1).
  - b. PN: 4002871 must be installed on the right-hand side of the planter.
2. Verify LED light #1 on the WSM control module is flashing green. This indicates that the entire Local CAN Bus is communicating appropriately.
3. Verify the LED light on the all of the RUMs is flashing green. This indicates that RUM is communicating on the Local CAN Bus.

- 
4. Check the connection, pins, and wires of the following Local CAN components. Any faulty component may cause the RUM detection process to fail.
    - a. ISOBUS Breakout Cable - PN: 4002597-008
    - b. (if applicable) CAN Repeater Cable – PN: 4004310-008
    - c. Local CAN Bus Extension Cable – PN: 4002807-X
    - d. Row Unit CAN Stub Cable – PN: 4004311-4
  5. To narrow down a faulty component, begin with a fewer amount of RUMs on the Local Bus. The Local CAN terminators may be moved inward and connected to any Local CAN stub or extension cable. (i.e. Terminate after the middle 2 RUMs; therefore only 2 RUMs will now detect when the WSM control module is powered on) Cycle power each time the terminators are moved.
    - a. Proceed to move the terminators inward or back-out depending on the results of the new detection.
  6. Verify that the WSM control module firmware is up to date.
  7. A module Reset may be required if the WSM control module keeps booting to Demo Mode or with the incorrect number of RUMs detected.
  8. If schematics are available, check continuity and/or power on suspect components.

## Implement Switch Adjustment Problems

**Problem A:** Down Force is too high at the beginning of a pass after the planter has been raised.

This problem can be caused by the implement switch tripping too late when the planter is being raised. If a row with a gauge wheel sensor comes off the ground before the implement switch trips, there is the chance the sensor will register no gauge wheel load and the system will react to it and apply down force. Once the switch trips, this higher down force is now held. When the planter resumes, down force may be initially excessive until it can relieve pressure.

**Solution:** Adjust the implement switch mounting so that it trips sooner when raising the planter. This will allow the system to hold the appropriate amount of down force.

**Problem B:** Low gauge wheel load is witnessed on a row causing the system to apply Max down force; but after inspection of the seed trench, the problem row appears to be receiving adequate gauge wheel load.

# ISOBUS Hydraulic Down Force

This problem can be caused by the implement switch tripping too late when the planter is being lowered. If a row with a gauge wheel sensor makes contact with the ground before the implement switch trips, there is the chance the sensor will register a load. Since the implement switch has not tripped yet, the gauge wheel sensors are still continuously re-zeroing every second, after the initial 10 seconds. (Ex: 50 lbs of actual load may be displayed as 0 lbs). The down force system will detect the “lower gauge wheel load” and react to it by applying more down force until the sensor reaches an acceptable load.

**Solution:** Raise the planter to allow the sensors to re-zero with no load on the gauge wheels. Adjust the implement switch so that it trips sooner when lowering the planter. This will prevent the false gauge wheel load readings.

## Module Diagnostic Lights



### WSM Down Force Module

⊕ **High Power** – Indicates 12V high current power to the module.

Status	Definition
OFF	No Power
Blinking Yellow	Firmware Upgrading
Solid Green	High Power OK

1. Local CAN – Indicates if the WSM is communicating with the RUM's.
2. Display CAN – Indicates if the WSM is communicating with the controlling display.

Status	Definition
OFF	No CAN Communication
Solid Red	CAN BUS Off
Solid/Blinking Yellow	CAN BUS Error
Blinking Green	CAN BUS Communicating

### Row Unit Module (RUM)



Status	Definition
OFF	No CAN Communication
Solid Red	CAN BUS Off
Solid/Blinking Yellow	CAN BUS Error
Blinking Green	CAN BUS Communicating

**Implement Switch Module**



**Left LED**

Status	Definition
OFF	No CAN Communication
Solid Red	CAN BUS Off
Solid/Blinking Yellow	CAN BUS Error
Blinking Green	CAN BUS Communicating

**Right LED**

Status	Definition
OFF	Planter Raised
Solid Blue	Planter Lowered



# Hydraulic Down Force–2 Channel

The gauge wheel sensors measure the weight carried by the gauge wheels. The system uses this information to adjust the down force so that the planter is firmly on the ground, to ensure correct planting depth, while trying to reduce any compaction risk.

## Load Configuration



Press the Planting App from the home screen. This will take you through the steps needed to load a configuration.

## Map View

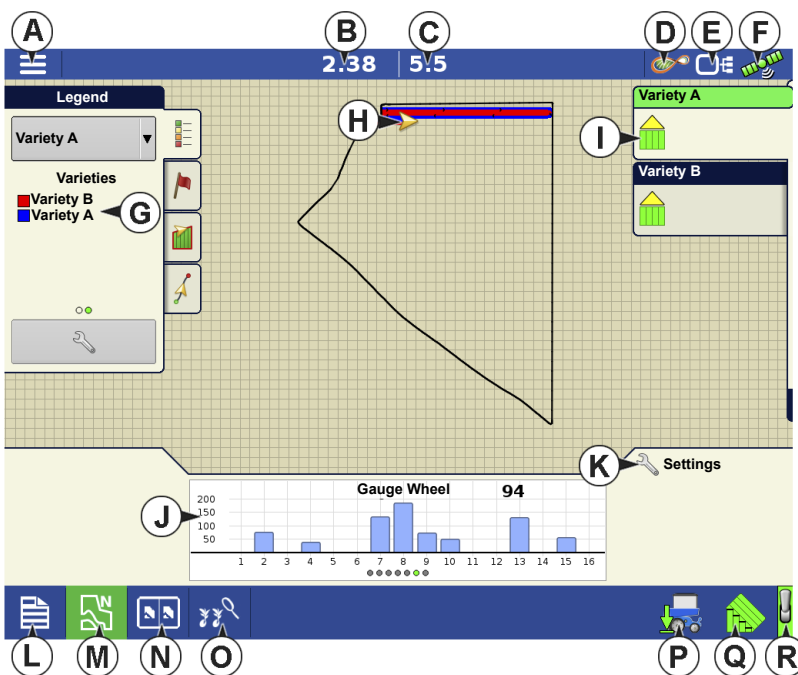

Once a configuration has been completed, the Map View screen appears.

A. Menu button

B. Total Logged Field Area

C. Ground Speed

D. AgFiniti® Status Indicator

E. Diagnostics

F. GPS Signal Indicator

G. Display Legend

H. Vehicle Icon

I. Product Control toolbox

J. Bar Graph

K. Settings button

L. Event Summary

M. Map View

N. Split screen

O. Advance Seed Monitoring

P. Down Force Icon

Q. AutoSwath

R. Master Switch Status



**NOTE!:** Pressing the Map View button will cycle between the available Map Screen views, and the appearance of the Map View button changes.

## Bar Graphs on Run Screen

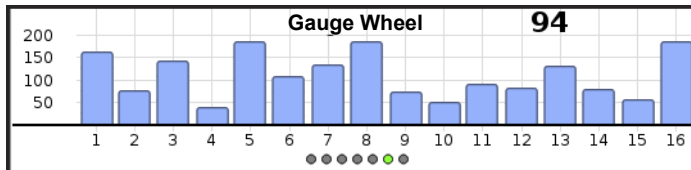

Bar Graphs on Run Screen show **Gauge Wheel Load** and **Down Force** being applied to row unit. Swipe bar graph to advance to next graph. Bar graph may also contain graphs for Advanced Seed Monitoring.

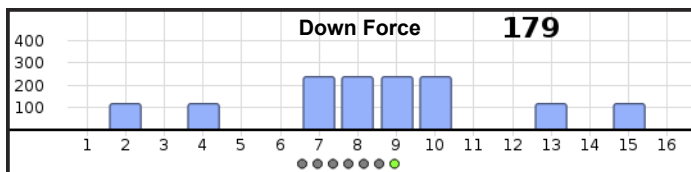

Down Force is not shown when in Monitor Only mode.

## Planter Performance Screen

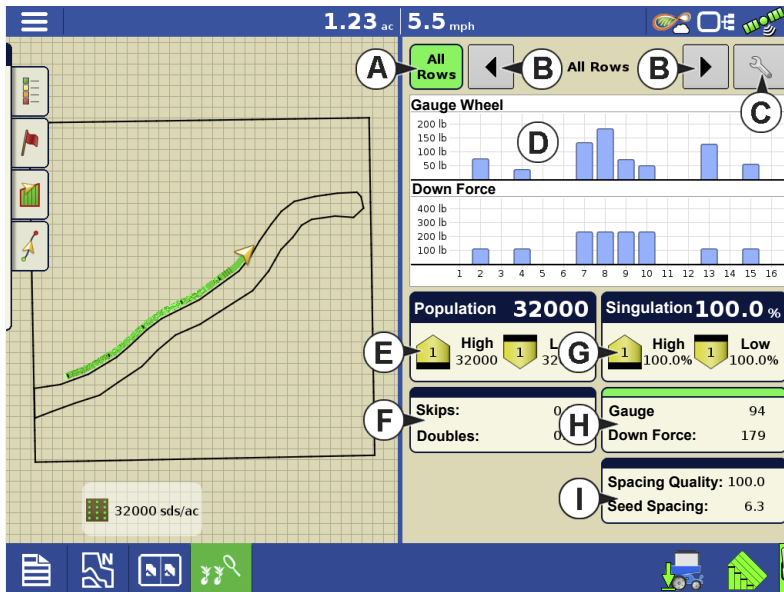

Press Advanced Seed Monitoring button

A.All Rows

B.Previous/Next Row Toggle

C.Seed Monitor Options

D.Bar Graph

E.Population

F.Skips/Doubles

G. Singulation

H. Down Force

## I. Spacing Quality



**NOTE!** The Planter Performance Screen will only be available if a seed monitor module is connected and configured.

Screen will show Gauge Wheel readings and Down Force across the row sections of the planter.

Down Force will not be shown when using Monitor Only

Advanced Seed Monitoring provides planter performance monitoring of seed meter singulation, skips/doubles and spacing quality, along with population and spacing information for all rows when planting compatible crops.

### Down Force Status

Icon on the lower right side of Map Screen shows the status of Down Force.



**Active** - Hydraulic Down Force is in an Active state - automatically controlling the down force per channel based on the gauge wheel load readings. To be Active, the implement switch needs to be in a planting state, speed needs to register on the display greater than 0.5 mph (0.8 km/h), and the tractor hydraulics engaged.



**Inactive or Hold** - Hydraulic Down Force is in an Inactive state or Hold state. Planter is either raised, the display is not registering speed, or Automatic Hold is active while planting in an AutoSwath area.



**Manual Mode** - Hydraulic Down Force is in Manual Mode. Manual Mode can be activated from the Planter Options screen.



**Manual Hold** - Hydraulic Down Force is in a Hold state - this Hold state is activated by the operator by toggling the Down Force icon. The Hydraulic Down Force can be set to an Active state by toggling the Down Force icon again, or raising and lowering the planter.



**NOTE!** Manual Hold can be a useful tool for operators who wish to Hold down force in certain areas of their fields, instead of letting the Hydraulic Down Force system actively control in these said areas.

## Planter Options Screen

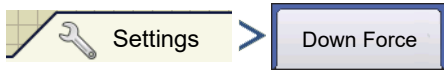

OR

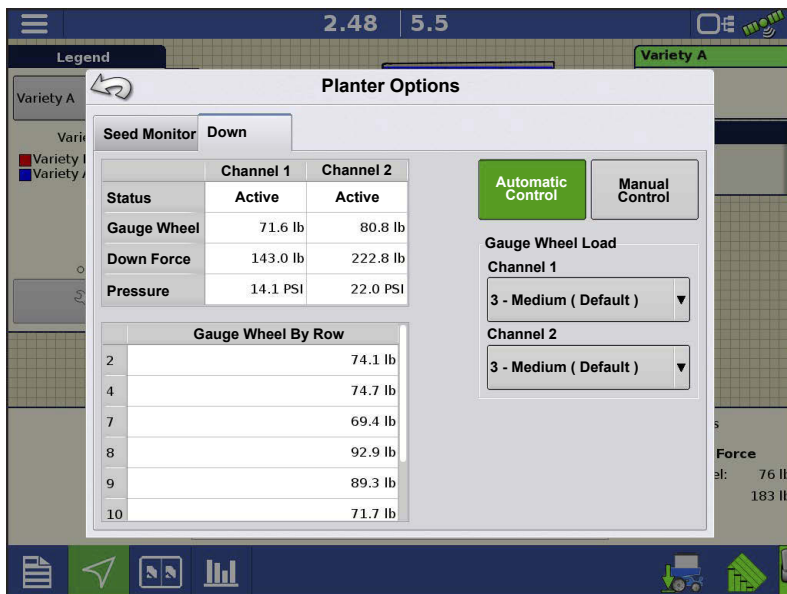
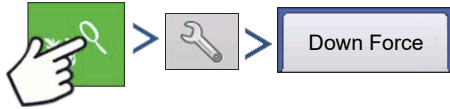

Automatic Control

Selecting Automatic Control enables the system to control down force based on gauge wheel sensor readings.

Manual Control

Selecting Manual Control enables the operator to set the downforce as they

see fit.

**Status**—Displays current status of control system.

- **Active**—System is actively controlling down force
- **Inactive**—System is not actively controlling down force
- **Hold**—Pressure is being held constant due to manual hold or automatic hold

**Gauge Wheel**—Instantaneous channel average gauge wheel load

**Down Force**—Instantaneous supplemental down force

**Pressure**—Pressure reading from corresponding channel pressure transducer

# Hydraulic Down Force–2 Channel

**Gauge Wheel By Row (table)**—Instantaneous gauge wheel load for each monitored row



**ATTENTION!:** Gauge wheel sensors will “re-zero” when the planted is raised for 10 seconds, and will then continue to re-zero every second until the planter is in a down state. Re-zeroing provides more accurate gauge wheel data upon each planting pass. This is also a good troubleshooting measure to determine if a gauge wheel sensor is behaving appropriately.

However, gauge wheel sensors will never re-zero to 0.0 lbs; once a sensor re-zeros the displayed load should be roughly anywhere from 0.1 to 5.0 lbs.

## Gauge Wheel Load

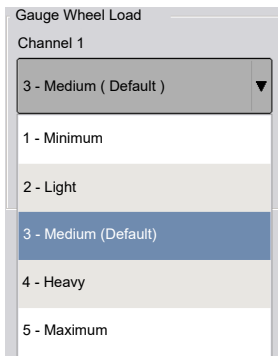

Set offset to target gauge wheel load as calculated by the down force system.



**ATTENTION!:** User can select 1 of 5 available gauge wheel load settings. Each available setting is an offset to the continuously calculated target gauge wheel load. Target Gauge Wheel Load is defined as: The amount of gauge wheel load necessary to achieve proper depth 100% of the time, while minimizing compaction as much as possible (without risking loss of proper planting depth).

Setting	Offset to Target
Minimum	-100 lbs
Light	-50 lbs
Medium (default)	0
Heavy	+50 lbs
Maximum	+ 100 lbs

Example: Based on the ground conditions in a specific area of a field, the down force system applies 150 lbs of supplemental force in order to achieve a target gauge wheel load of 100 lbs. However, if the Gauge Wheel Load setting is set to **Heavy**, the target gauge wheel load is now 150 lbs. The supplemental force will adjust accordingly in order to achieve the new target gauge wheel load. (Keep in mind, the target gauge wheel load is a continuously calculated value.)



**WARNING!:** When operating on light or minimum, shallow planting can occur.

## Create Configuration

A wizard will guide you through the process of selecting or creating a configuration with application settings.

The configuration can be started in two places:



OR

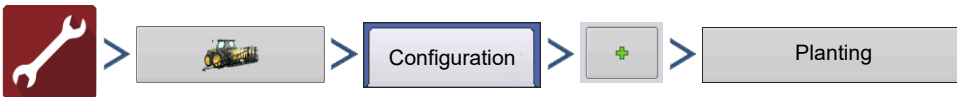

Your Operating Configuration will then be viewable when you start a new Field Operation with the Application Wizard.

You can also use the **Manage Equipment** button to create or edit specific vehicles and implements.

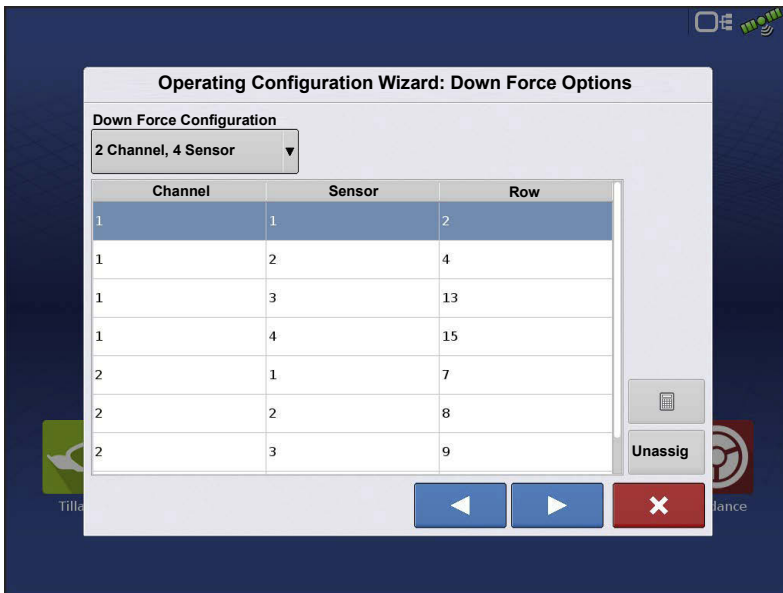

At the **Down Force Options** screen, the operator can choose a Down Force configuration from the drop down menu:

The rows listed are the recommended rows where the sensors should be installed.



The operator can assign rows if custom installed. (Select **Custom**

from the drop-down menu.)

User can also unassign sensors from rows if a sensor is not installed there.

# Hydraulic Down Force–2 Channel

Row 1 is the on the left side of the planter (when standing behind the planter facing forward).

## Setup Down Force Configuration



## Down Force screen General tab

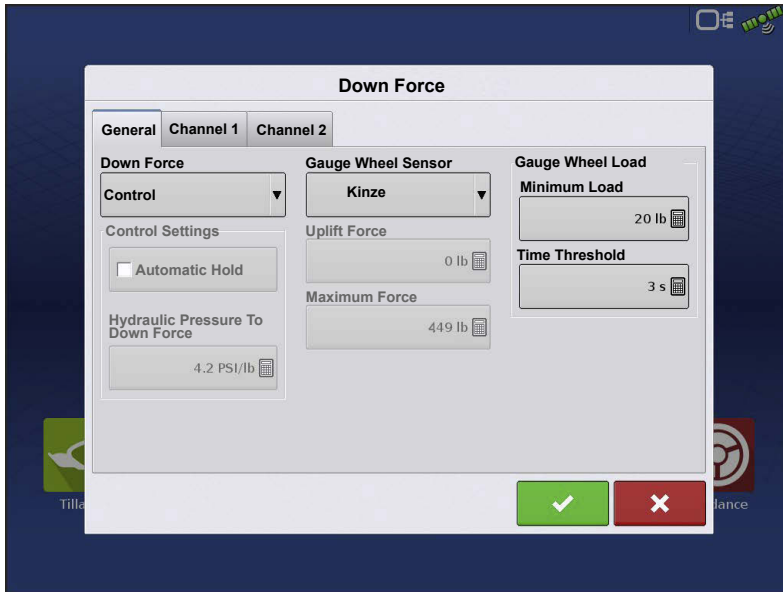

### Down Force Mode

**Monitor Only mode**—provides the operator with information to determine if the row units are properly engaging the soil. If they are not, the operator needs to adjust the planter to correct the situation.

- Allows user to monitor the weight on the gauge wheels but does not adjust down pressure.

- Control Settings (Automatic Hold and Hydraulic Pressure to Down Force Conversion) are grayed out when using Monitor Only mode.

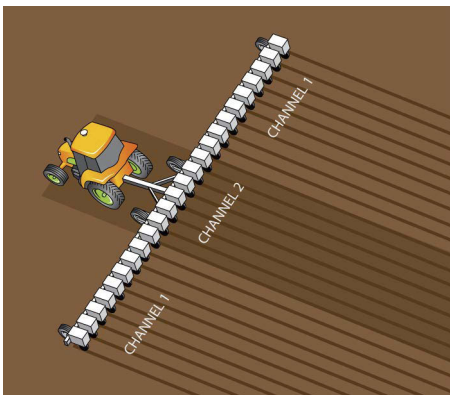

**Control mode**—as the planter travels across the field and encounters varying soil conditions (soil types, compaction zones, levels of debris) the display makes adjustments to the down force actuators on the row units, according to the operator's settings, to maintain the correct seed placement in the soil.



The system can be split between two channels to allow the down force to be adjusted separately on the planter wings and center section, where soil compaction is more likely to occur.

- Allows user to monitor the weight on the gauge wheels and have system automatically adjust down force.

**Automatic Hold**—Enabling this option will disengage active control (system will Hold), when any portion of

the planter enters a no plant zone, such as boundaries, or previously planted areas. Use **caution** with this option if planting long point rows. Alarms will be disabled when system is in Hold.

### Hydraulic Pressure to Down Force Conversion

Adjusts system to accurately display changes to hydraulic down force. This setting is row unit specific.

Force Conversions	
Parallel Linkage	Pressure Conversion
Deere Short Arm	4.5 psi/lb
Deere Long Arm	3.8 psi/lb
Kinze 3000	4.2 psi/lb
Kinze 4000	5.1 psi/lb
White 8000/9000	4.8 psi/lb

**Gauge Wheel Load Sensor**—type of gauge wheel load sensor used. This is specific to the make of your planter.



**NOTE!:** There are two selections for John Deere gauge wheel sensors. Select the appropriate one based on the part number installed on the planter. Only ONE John Deere sensor type can be installed; the two John Deere types are not compatible together on the same planter.

### Uplift Force



# Hydraulic Down Force–2 Channel

Usually 0 unless planter is equipped with uplift springs to provide an upward force on row units.

Uplift Force	
Parallel Linkage	Uplift Force
Deere Short Arm	140 lbs
Deere Long Arm	
4 spring design	160 lbs
2 spring design	100 lbs
Kinze 3000	140 lbs
Kinze 4000	130 lbs
White 8000/9000	100 lbs

**Maximum Force**—used to limit the down force created by the actuator. The default is 425 lbs same as the factory airbag.



**NOTE!:** When an uplift force amount is entered the actual Maximum Allowable Force that can be applied is now increased by that amount, in order to accommodate for the uplift. This takes place internally in the control module and is not displayed to the operator. Operators should enter Force Settings as they normally would.

**Gauge Wheel Load Alarm**—sets alarm to notify operator when system goes below Minimum Gauge Wheel Load for a set amount of time (Time Threshold).

## Down Force Channel 1 and Channel 2 tabs

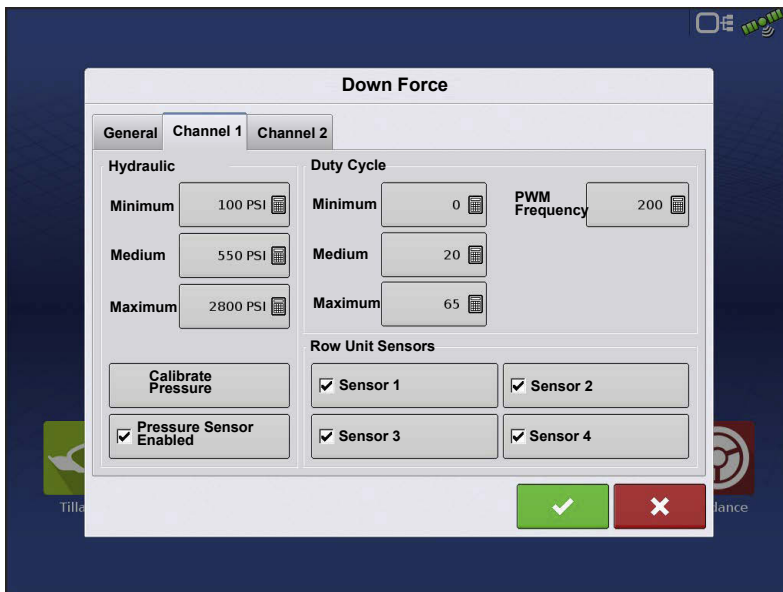

The pressure and duty cycle settings are to help the display control the hydraulics. The defaults should be correct.

Hydraulic Pressure (Unavailable for Monitor Only)		
AgLeader Valve Block Calibration		
Operating Limits	Pressure	Duty Cycle
Minimum	100	0
Medium	550	20
Maximum	2800	65

**PWM Frequency**—The frequency that the PWM control valve is pulsed at should be set to 200.

**Calibrate Pressure Sensor**—Unavailable for Monitor Only

**Pressure Sensor Enable**—Unavailable for Monitor Only

**Row Unit Sensors**—Sensors 1-4 check boxes. These check box's allow the operator to disable gauge wheel sensors. If a sensor fails in-field, the failed sensor can be disabled from this screen.



**ATTENTION!**: Automatic Down Force can continue to operate as long as there is 1 active sensor on a channel.

## Calibrate Pressure Sensor

(Only able to calibrate when Control Mode has been selected)



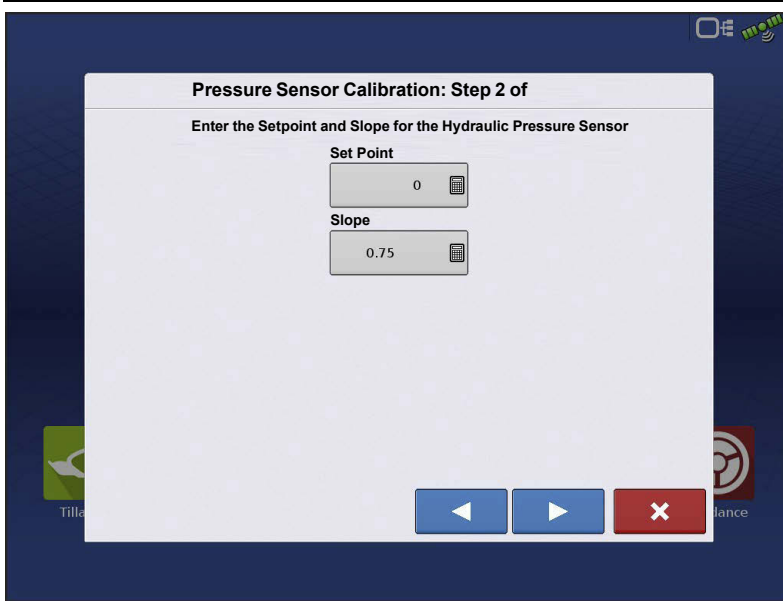

## Hydraulic Down Force–2 Channel

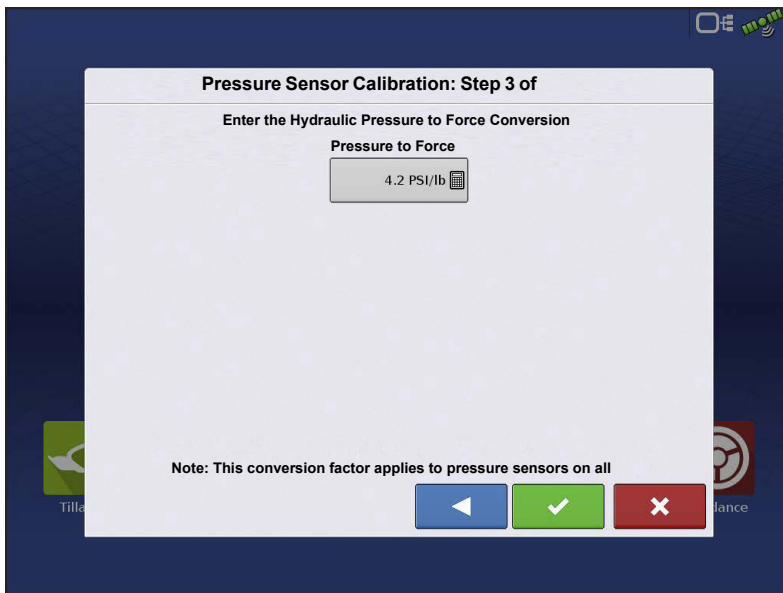

**Setpoint**—enter the current pressure of the system found on the mechanical pressure gauge on the valve block

**Slope**—pressure sensor calibration, do not adjust this value



**Pressure to Force**—Enter the specific pressure to force conversion ratio for the planters parallel linkage arm. Press the . Pressure Sensor Calibration is complete.

 **NOTE!** Pressure Sensor must be enabled in order to display "Down Force" on the run screen for that specific channel of control.

## Down Force Diagnostics screen

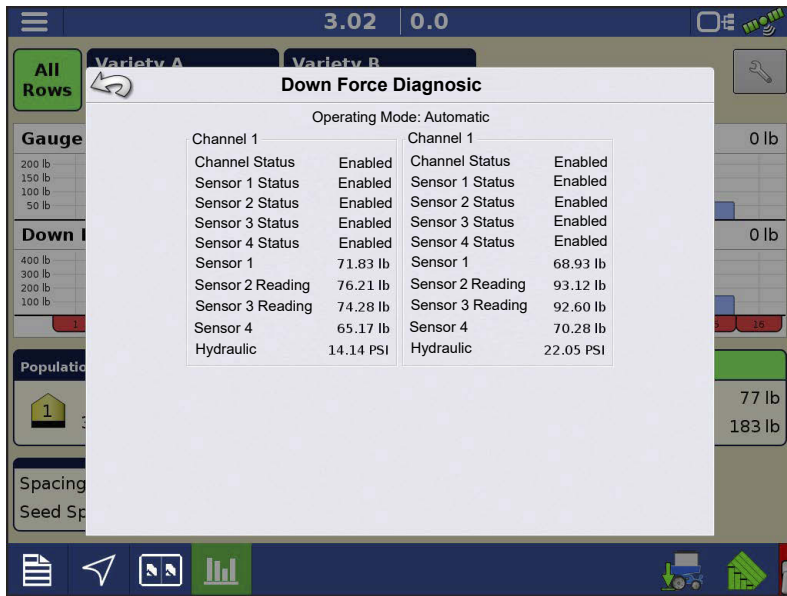

Pressing on the CAN button, located in the upper right corner of the display, opens the **Devices** screen. Highlight the **Down Force Module** in the CAN A tab and press the **Diagnostics** button in the lower right-hand corner.

Technical support may request that you look at these screens for help in diagnosing a problem.

In this screen you can view the current **Operating Mode**, **Channel Status**, individual **Sensor Status**, individual **Sensor Readings**, and **Hydraulic Pressure**.



**NOTE!:** Sensor Readings are the raw pound value being received by the Control Module. The value seen on Diagnostic screen is not dependent on the planter operational state, therefore making this a valuable tool to diagnosis sensor issues or inaccuracies.

## Down Force Alarms

### Down Force Inadequate

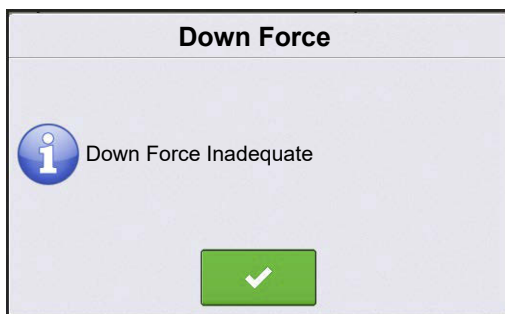

System hydraulic pressure is at maximum pressure, but the Down Force system is not achieving acceptable gauge wheel load.

**Recommendation**—If supplemental force is at maximum, increase Maximum Force on the Down Force setup screen.

-Planter may not weigh enough to handle field conditions - toolbar may be lifting. Verify if the toolbar is lifting by checking parallel arms while planting. If weight needs to be added to the toolbar, contact planter manufacturer.

### Low Gauge Wheel Load

## Hydraulic Down Force–2 Channel

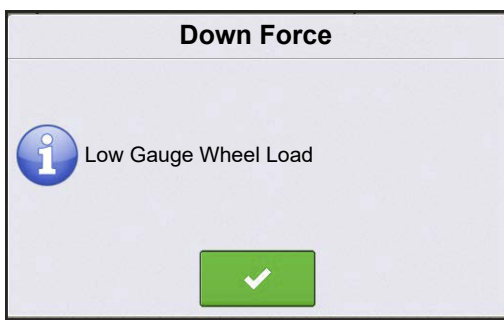

**Down force system does not achieve acceptable gauge wheel load**

User defined alarm to signal operator if planter is losing planting depth.

### Hydraulic Pressure too low

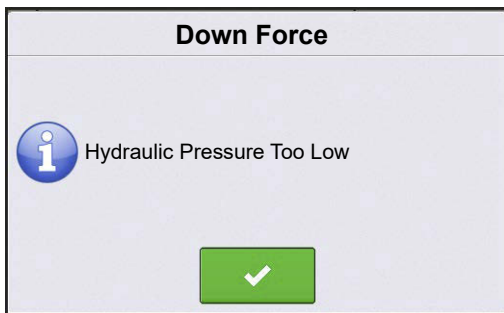

Down force system commanding more down force but hydraulics are not reacting

#### **Recommendations:**

- Check tractor remote is on
- Check that enough hydraulic fluid is directed to down force system

### Pressure Sensor Failure

**Problem**—Pressure sensor is outside voltage range.

**Resolution**—swap cables with other channel (if applicable), re-zero pressure sensors. If problem persists on same channel, replace pressure sensor. If problem is now on other channel, inspect/replace cable.

### Row Module Communication Lost

**Problem**—Row module communication lost.

**Resolution**—Inspect cabling of row module. Replace row module.

### Row Module Failure

**Problem**—Row module is not sensing inputs. Row module is power cycling at intervals of less than 2 seconds

**Resolution**—Swap module with different row. If problem follows, replace module. If problem exists on same row, inspect or replace load sensor.

### # Row Modules does not match the display configuration

**Problem**—Configuration was set to a number of sensors that was not detected by the system.

---

**Resolution**—Create a configuration that matches the number of sensors used. Check that all row modules are communicating. Flashing green LED on the row module indicates proper communication.

## How to use Manual Override

Manual Override of the control valve may be needed if all electronic control of the Down Force System is lost, or the display becomes unusable. Manual Override allows the Down Force system to apply a constant force in order to achieve planting depth (similar to down force springs). If the need arises to put the control valve into Manual Override, follow these steps.

Steps:

1. Engage hydraulics for the Down Force system.
2. Locate the Down Force control valve. Push the red knobs down and twist. The knobs will "pop out" to their outer position. (The inner position is used for Auto Control).
3. Locate the allen head adjustments just above electronic PWM valve. Loosen the lock nuts on the allen head adjustments.
4. Screw the allen head adjustment IN to increase pressure sent to actuators; screw OUT to decrease pressure.

Pressure (PSI) sent to actuators is shown on analog gauges on the valve block.

5. Refer to the Down Force setup screen and note the Hydraulic Pressure to Down Force Conversion ratio. Multiply this value by the desired down force; this will give you the appropriate pressure to adjust the valve to.

Example: Kinze 3000 planter = 4.2 PSI/lb. The desired down force is 250 lbs.

4.2 .PSI/lb x 250 lbs = **1050 PSI**.

## FAQ

### **What do I set the input hydraulic source to?**

The vehicle hydraulic source (SCV) will need to be set at max flow.

### **Where do I plug in an implement switch?**

Generation 1 modules will broadcast the implement switch status over the CAN bus. No additional implement switch is needed.

### **What if I don't have any other generation 1 modules?**

You will use the Ag Leader CAN implement switch module P/N 4002911 and cable P/N 4002658 in conjunction with the standard implement switch.

### **What if my cables don't reach the rows for which I have installed gauge wheel sensors?**

It may be acceptable to choose rows the cables will reach, as long as channel 2 sensors are on the center 6 rows, and channel 1 sensors are outside that.

### **What if I don't have any free SCV connections for the down force valve?**

Teeing into existing lines is acceptable. Do not tee into the vacuum fan line if adjusting fan RPM on the tractor with a knob or dial. Teeing into the line before a flow limiter on the planter would be acceptable. Teeing into the hydraulic drive supply line would be the best option. Do not tee into Rawson Drive supply line.

### **What if my hydraulic oil gets too hot?**

Ag Leader sells a Load Sense kit (P/N 4101225) to help manage oil temperatures. Note: This system will not help if using SCV to control hydraulic drives. In this case, an auxiliary oil cooler may need to be installed.

### **What if my hydraulic actuator does not extend far enough to reach the lower bracket with row unit at bottom travel?**

Purchase one spacer kit (P/N 4101201) per row. This will install at the bottom of the ram.  
(Commonly used on John Deere long parallel arms)

### **My Kinze 3000 planter has rows that are offset 4" back, causing the upper actuator bracket to not line up with the lower actuator bracket.**

---

Purchase one spacer kit (P/N 4101204) per row. This will move the upper bracket 4" rearward.

### **How does the system know the difference between the row modules on channel 1 and those on channel 2?**

The Channel 1 row modules will connect to the cable labeled "Type 1" while channel 2 row modules will connect to "Type 2" cables.

### **Am I missing something to plug into the 3 pin connector on the master hydraulic down force module?**

This connector is not used.

### **Why is the gauge wheel load bar graph constantly spiking and then going to 0?**

This can happen if the Channel 1 pressure lines are routed to channel 2 sensors. Ensure channel 1 components (Down force pressure, and gauge wheel load sensor wiring) are on the wings, and channel 2 components are on the center 6 rows. Ensure channel hoses are going to correct channel of down force valve. Ensure PWM/pressure sensor cables are going to correct channel of Down Force Module and Down Force Valve.

### **What are the red knobs on the down force valve?**

This allows for manual adjustment of down force in the event of electronics failure. Push and twist the knob to move between automatic adjustment (inner position) and manual adjustment (outer position).

### **Why does the system need 3 hydraulic lines (Pressure, Return and Tank)**

Under normal operation, pressure in the down force system is increased through the Pressure line and relieved through the Return line. When the planter runs over a terrace or a water way, the excess pressure is released through the Tank line. All three lines MUST be connected.

### **What happens if my Pressure and Return hoses are connected backwards on my Hydraulic Down Force valve block?**

If the Pressure and Return hoses are connected backwards on the Hydraulic Down Force valve block, the hydraulic flow will be sent directly to the channels connected to the valve block. Once this happens, the actuators on all of the channels will be applying max



## Hydraulic Down Force–2 Channel

---

supplemental force. On the screen of the controlling display, this may likely result in very high gauge wheel load. This will occur on all variations of valve blocks that Ag Leader supports.

### Can an open-center tractor be used for Ag Leaders Hydraulic Down Force

Open center tractors are not recommended for use with Ag Leaders Hydraulic Down Force.

## Troubleshooting

**Problem**—Down Force will not adjust in Auto Control while planting (Down Force Holds)

- Down Force indicator arrow stays Yellow while planting.

### Solution:

- Verify implement switch(s) polarity is correct.
  - Verify implement switch(s) are tripping when planter is lowered.
1. With planter lowered, verify implement switch(s) have tripped.
  2. Check the polarity of the implement switch is correct. Implement switches can be swapped from Normally Open to Normally Closed by switching 3-pin weatherpack connections.
  3. If Generation 1 SeedCommand® modules are installed, verify the implement switch(s) is hooked to the correct module according to the hierarchy.
    - If an Implement Switch module is installed, verify the indicator light turns blue on the module when the switch is tripped.
  4. Check mounting of implement switch(s).
  5. While operating Down Force, verify the toolbar is not lifting causing the implement switch to trip.



**ATTENTION!:** Gauge wheel sensors will "re-zero" when the planter is raised for 10 seconds and will then continue to re-zero **every second** until the planter is in a down state. Re-zeroing provides more accurate gauge wheel data upon each planting pass. This is also a good troubleshooting measure to determine if a gauge wheel sensor is behaving appropriately.

*However, gauge wheel sensors will never re-zero to 0.0 lbs; once a sensor re-zeros the displayed load should be roughly anywhere from 0.1 to 5.0 lbs.*

---

**Problem**—Supplemental Force and Gauge Wheel Load do not appear to reflect each others responses. (Ex: High Gauge Wheel Load on Channel 1, with very little Supplemental Force being applied, or vice versa)

**Solution**—Verify installation of the Local CAN terminators.

1. The Local CAN is the communication wiring bus that transfers the gauge wheel load readings to the main control module. There needs to be a terminator on each end of this bus.
2. Terminator PN 4002870 will need to be installed on the wiring harness closest to row 1. Terminator 4002871 will need to be installed on the wiring harness closest to the end of the planter (right-hand side when looking at planter from the rear)

## Implement Switch Adjustment Problems

**Problem A**—Down Force is too high at the beginning of a pass after the planter has been raised.

This problem can be caused by the implement switch tripping too late when the planter is being raised. If a row with a gauge wheel sensor comes off the ground before the implement switch trips, there is the chance the sensor will register no gauge wheel load and the system will react to it and apply down force. Once the switch trips, this higher down force is now held. When the planter resumes, down force may be initially excessive until it can relieve pressure.

**Solution**—Adjust the implement switch mounting so that it trips sooner when raising the planter. This will allow the system to hold the appropriate amount of down force.

**Problem B**—Low gauge wheel load is witnessed on a row causing the system to apply Max down force; but after inspection of the seed trench, the problem row appears to be receiving adequate gauge wheel load.

This problem can be caused by the implement switch tripping too late when the planter is being lowered. If a row with a gauge wheel sensor makes contact with the ground before the implement switch trips, there is the chance the sensor will register a load. Since the implement switch has not tripped yet, the gauge wheel sensors are still continuously re-zeroing every second, after the initial 10 seconds. (Ex: 50 lbs of actual load may be displayed as 0 lbs). The down force system will detect the “lower gauge wheel load” and react to it by applying more down force until the sensor reaches an acceptable load.

## Hydraulic Down Force–2 Channel

---

**Solution**—Raise the planter to allow the sensors to re-zero with no load on the gauge wheels. Adjust the implement switch so that it trips sooner when lowering the planter. This will prevent the false gauge wheel load readings.



# Hydraulic Down Force–Individual Row

The gauge wheel sensors measure the weight carried by the gauge wheels. The system uses this information to adjust the down force so that the planter is firmly on the ground, to ensure correct planting depth, while trying to reduce any compaction risk. Individual Row Hydraulic Down Force control is only available with the InCommand™ 1200 display.

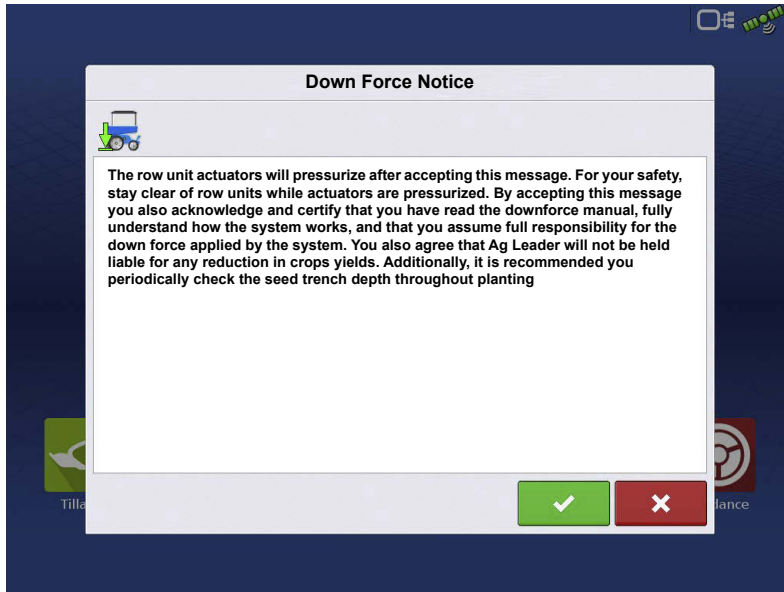

Upon starting the display, you will receive the Down Force Notice that will need to be accepted in order to operate the Hydraulic Down Force system.

## Load Configuration



Press the Planting App from the home screen. This will take you through the steps needed to load a configuration.

# Map View

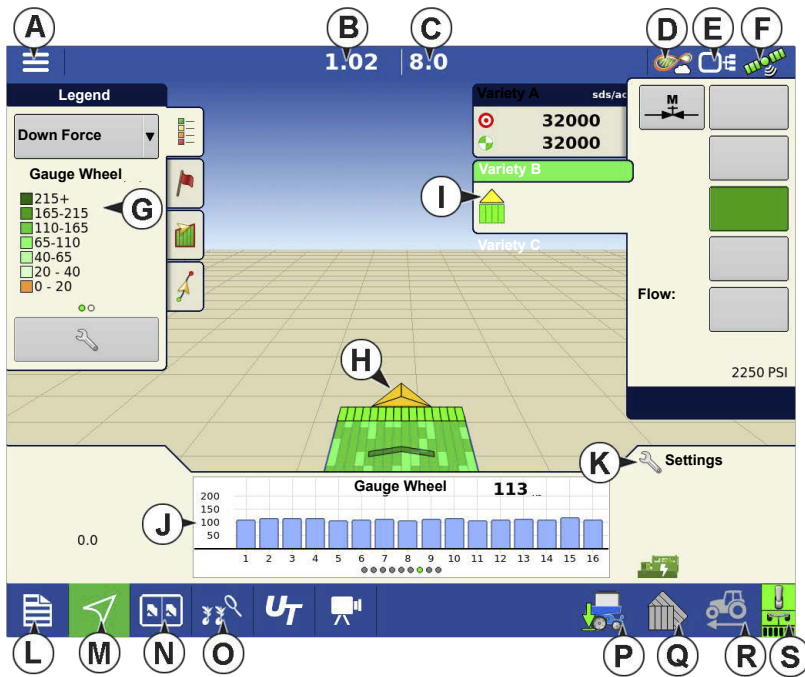

Once a configuration has been completed, the Map View screen appears.

- A.Menu button
- B.Total Logged Field Area
- C.Ground Speed
- D.AgFiniti® Status Indicator
- E.Diagnostics
- F.GPS Signal Indicator
- G.Display Legend
- H.Vehicle Icon

I. Product Control toolbox

J. Bar Graph

K. Settings button

L. Event Summary

M. Map View

N. Split screen

O. Advance Seed Monitoring

P. Down Force Icon

Q. AutoSwath

R. Jump Start

S. Master Switch Status

Real time individual row down force data is available on the Map View screen; both Gauge Wheel load and Supplemental Force data is mapped. To display either the Gauge Wheel load or Supplemental Force, select Down Force from the Legend tab. Then swipe the Display Legend (G) left/right to change between Gauge Wheel load and Supplemental Force.

# Hydraulic Down Force—Individual Row



**NOTE!:** Pressing the Map View button will cycle between the available Map Screen views, and the appearance of the Map View button changes.

## Bar Graphs on Run Screen

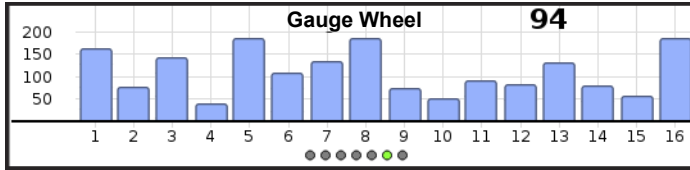

Bar Graphs on Run Screen show **Gauge Wheel Load** and **Down Force** being applied to row unit. Swipe bar graph to advance to next graph. Bar graph may also contain graphs for Advanced Seed Monitoring.

Bar graph may also contain graphs for Advanced Seed Monitoring.

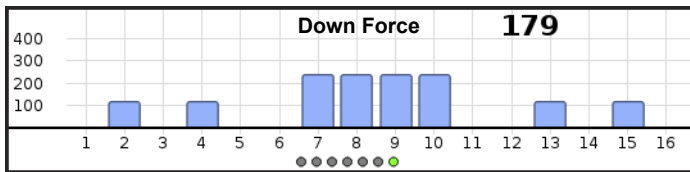

Down Force is not shown when in Monitor Only mode.

## Planter Performance Screen

Press Advanced Seed Monitoring button



A.All Rows

B.Previous/Next Row Toggle

C.Seed Monitor Options

D.Bar Graph

E.Population/Singulation

F. Skips/Doubles

G. Spacing Quality/Seed Spacing

H. Meter Speed

I. Gauge Wheel/Down Force

J. Down Force Trends

---

Screen will show Gauge Wheel readings and Down Force across the row sections of the planter.

Down Force will not be shown when using Monitor Only

Advanced Seed Monitoring provides planter performance monitoring of seed meter singulation, skips/doubles and spacing quality, along with population and spacing information for all rows when planting compatible crops.

## Down Force Status

Icon on the lower right side of Map Screen shows the status of Down Force.



**Active** - Hydraulic Down Force is in an Active state - automatically controlling the down force per channel based on the gauge wheel load readings. To be Active, the implement switch needs to be in a planting state, speed needs to register on the display greater than 0.5 mph (0.8 km/h), and the tractor hydraulics engaged.



**Inactive or Hold** - Hydraulic Down Force is in an Inactive state or Hold state. Planter is either raised, the display is not registering speed, or the implement is in an AutoSwath area.



**NOTE!:** With AutoSwath active, the entire planter bar will need to be in a previously applied area or boundary area in order for all rows to Hold the Supplemental Force.



**Manual Mode** - Hydraulic Down Force is in Manual Mode. Manual Mode can be activated from the Planter Options screen.



**Manual Hold** - Hydraulic Down Force is in a Hold state - this Hold state is activated by the operator by toggling the Down Force icon. **The Hydraulic Down Force can only be set back to an Active state by toggling the Down Force icon again.**



**NOTE!:** Manual Hold can be a useful tool for operators who wish to Hold down force in certain areas of their fields, instead of letting the Hydraulic Down Force system actively control in these said areas.



## Planter Options Screen



OR

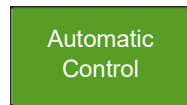
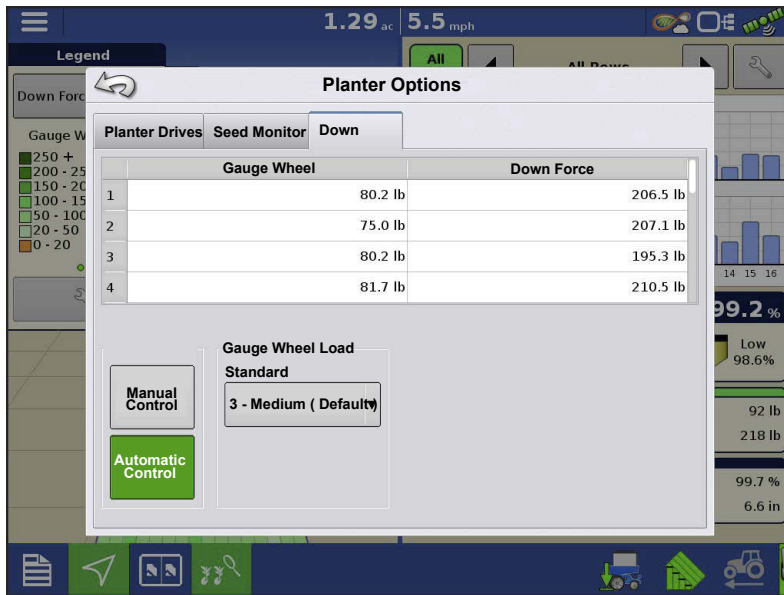

Selecting Automatic Control enables the system to control down force based on gauge wheel sensor readings.

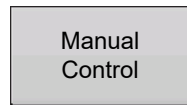

Selecting Manual Control enables the operator to set the downforce as they

see fit.

**Gauge Wheel**—Instantaneous gauge wheel load for each row. This is a raw sensor reading; it can be used for diagnostic purposes.

**Down Force**—Instantaneous supplemental down force for each row.

## Gauge Wheel Load

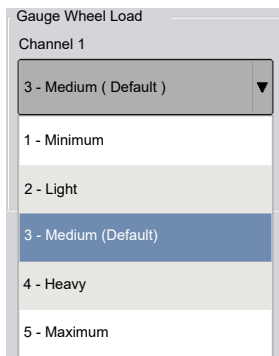

Set offset to target gauge wheel load as calculated by the down force system.



**ATTENTION!** User can select 1 of 5 available gauge wheel load settings. Each available setting is an offset to the continuously calculated target gauge wheel load. Target Gauge Wheel Load is defined as: The

---

amount of gauge wheel load necessary to achieve proper depth 100% of the time, while minimizing compaction as much as possible (without risking loss of proper planting depth).

Setting	Offset to Target
Minimum	-100 lbs
Light	-50 lbs
Medium (default)	0
Heavy	+50 lbs
Maximum	+ 100 lbs

Example: Based on the ground conditions in a specific area of a field, the down force system applies 150 lbs of supplemental force in order to achieve a target gauge wheel load of 100 lbs. However, if the Gauge Wheel Load setting is set to **Heavy**, the target gauge wheel load is now 150 lbs. The supplemental force will adjust accordingly in order to achieve the new target gauge wheel load. (Keep in mind, the target gauge wheel load is a continuously calculated value.)



**WARNING!:** When operating on light or minimum, shallow planting can occur.

## Create Configuration

A wizard will guide you through the process of selecting or creating a configuration with application settings.

The configuration can be started in two places:



OR



Your Operating Configuration will then be viewable when you start a new Field Operation with the Application Wizard.

# Hydraulic Down Force—Individual Row

You can also use the **Manage Equipment** button to create or edit specific vehicles and implements.

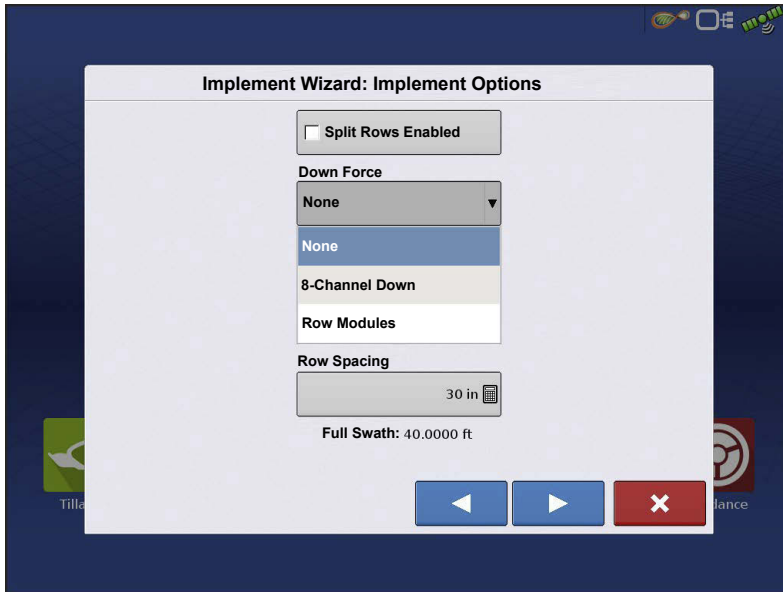

At the **Implement Options** screen, the operator can choose a Row Module from the Down Force drop down menu:

**NOTE!** This Implement Options screen will only be available if Electric Drive was previously chosen in the wizard as the Seed Rate Controller.

## Setup Down Force Configuration



## General tab

### Down Force Mode

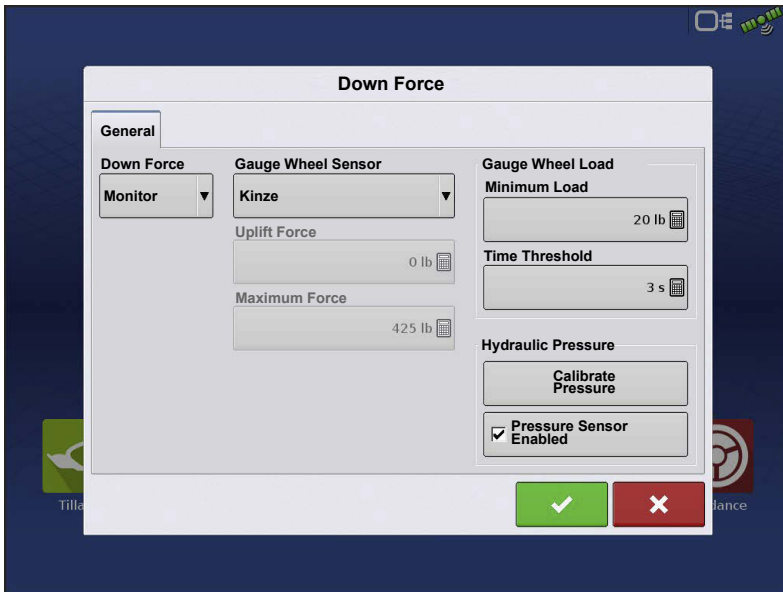

**Monitor Only mode**—provides the operator with information to determine if the row units are properly engaging the soil. If they are not, the operator needs to adjust the planter to correct the situation.

- Allows user to monitor the weight on the gauge wheels but does not adjust down pressure.
- Control related settings are grayed out when using Monitor Only mode.

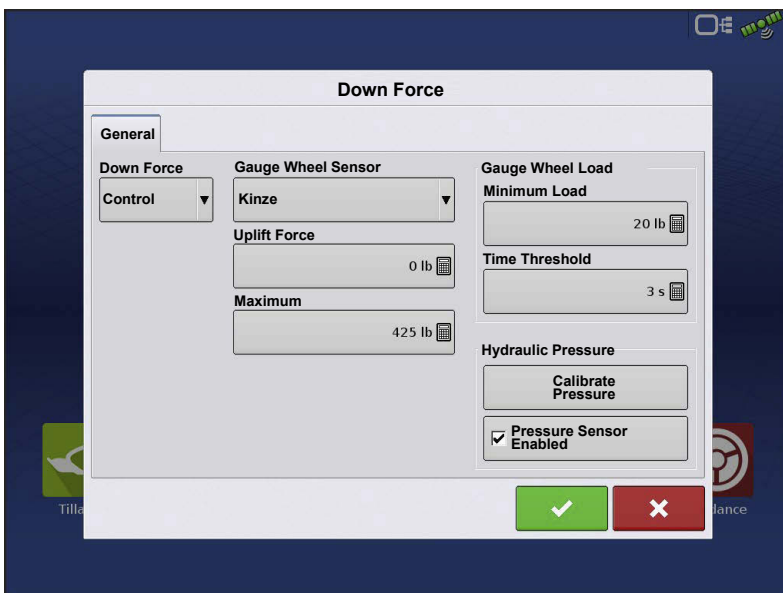

**Control mode**—as the planter travels across the field and encounters varying soil conditions (soil types, compaction zones, levels of debris) the display makes adjustments to the down force actuators on the row units, according to the gauge wheel load and the operator's settings, to maintain the correct seed placement in the soil.

**Gauge Wheel Load Sensor**—Identify the type of gauge wheel load sensor

used. This is specific to the make of your planter.



**NOTE!:** There are two selections for John Deere gauge wheel sensors. Select the appropriate one based on the part number installed on the planter. Only ONE John Deere sensor type can be installed; the two John Deere types are not compatible together on the same planter.

## Uplift Force

usually 0 unless planter is equipped with uplift springs to provide an upward force on row units.

### Uplift Force

Parallel Linkage	Uplift Force
Deere Short Arm	140 lbs
Deere Long Arm	
4 spring design	160 lbs
2 spring design	100 lbs
Kinze 3000	140 lbs
Kinze 4000	130 lbs
White 8000/9000	100 lbs

**Maximum Force**—used to limit the down force created by the actuator. The default is 425 lbs same as the factory airbag.



**NOTE!:** When an uplift force amount is entered the actual Maximum Allowable Force that can be applied is now increased by that amount, in order to accommodate for the uplift. This takes place internally in the control module and is not displayed to the operator. Operators should enter Force Settings as they normally would.

**Gauge Wheel Load Alarm**—sets alarm to notify operator when system goes below Minimum Gauge Wheel Load for a set amount of time (Time Threshold).

## Calibrate Pressure Sensor

(Only able to calibrate when Control Mode has been selected)

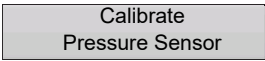
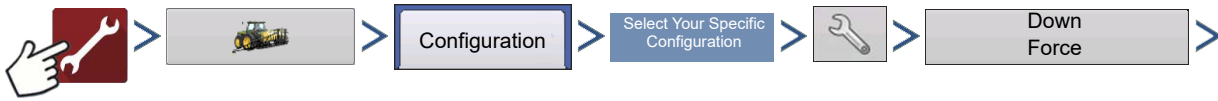

If the Hydraulic Pressure (PSI) reading in the Planter Control Master Module diagnostic screen is not accurately reflecting the pressure sent to the control valve, the operator can proceed to calibrate the pressure sensor in attempt and correct the PSI reading.

**Calibrate Pressure Sensor:**

1. Verify hydraulic pressure to the control valve is at 0 PSI. This can be achieved by turning the vehicle off, or disengaging SCV remote.

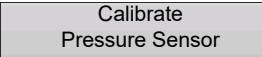
2. Press 

 **NOTE!:** No dialog or messages will appear when Calibrate Pressure Sensor is pressed.

3. Pressure sensor is now calibrated.

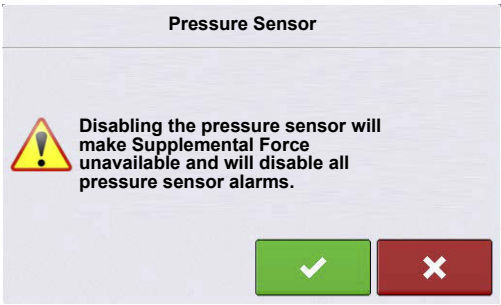

 **ATTENTION!:** If the Pressure Sensor Enabled box is unchecked, a warning message will appear. With the pressure sensor disabled, automatic down force control will still work as intended. However, there will be no Supplemental Force value, graphs, or pressure sensor

alarms.

## Advanced tab

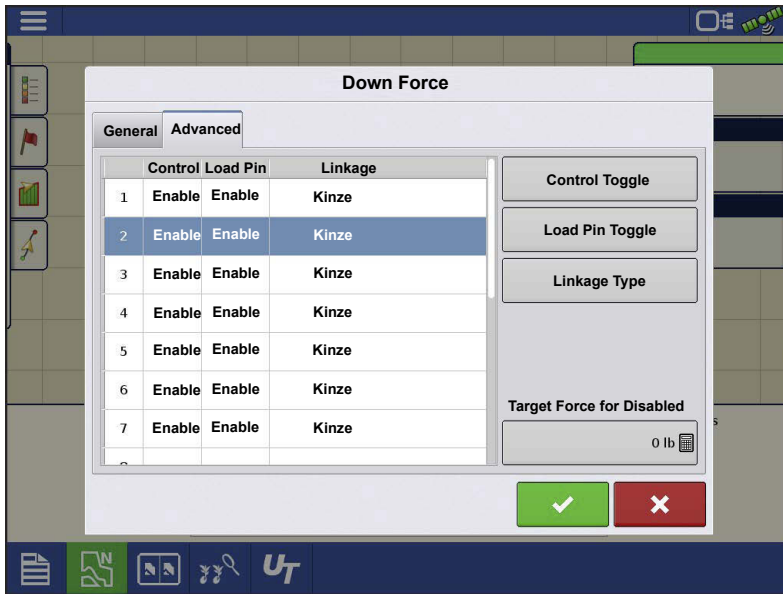

In order to access the Down Force Advanced tab, a configuration must be loaded. In the Advanced tab operator can disable a Load Pin or Down Force control, edit the row unit Linkage Type, and set a Target Force for Disabled Rows.

**Control Toggle** – This allows the operator to indicate if a row has hydraulic down force control. Pressing this button will change the Control

status to "Yes" or "No". Multiple rows can be selected together when toggling the control.

**Load Pin Toggle** — This allows an operator to disable a gauge wheel sensor if one fails in field or enable a sensor to just monitor a row. Pressing this button will change the “Enabled” status for that specific Load Pin to “Disabled”. Multiple rows can be selected together when disabling/enabling gauge wheel sensors.

**Linkage Type** — This allows the operator to change the row unit Linkage Type. Planters may have a combination of short and long parallel arms. Linkage type can be selected independently for each row. Multiple rows can be selected together when changing the Linkage Type.



**NOTE!:** John Deere Short parallel arms have an overall length of 15-3/4”. John Deere Long parallel arms have an overall length of 23”.

**Target Force for Disabled Rows** — This allows the operator to set a target Supplemental Force for a row with a Disabled Load Pin. For example, if row 1 is Disabled and 250lbs is entered in this box as the Target Force, row 1 will apply a constant 250lbs of Supplemental Force. The remaining Enabled Rows will continue to function in automatic control mode.



**WARNING!:** It is recommended to enter a Target Force for Disabled Row when a row(s) are Disabled. If this value is left at 0lbs, the Disabled row(s) will apply 0lbs of Supplemental Force.

## Monitoring Planter Rows in Conjunction with Controlled Rows



Individual Row Down Force allows the ability to monitor just gauge wheel load on some planter rows while continuing to hydraulically control the rest of the rows.

Example: A split row planter is setup to control down force on the standard rows, but also setup to just monitor gauge wheel load on the split rows. Split rows that have gauge wheel sensors will need to be set to No for

Control, and Enabled for Load Pin. (Split rows that don't have a gauge wheel sensor will need to be set to No for Control, and Disabled for Load Pin.) All standard rows will need to be set to Yes for Control, and Enabled for Load Pin.

## Diagnostics Screen

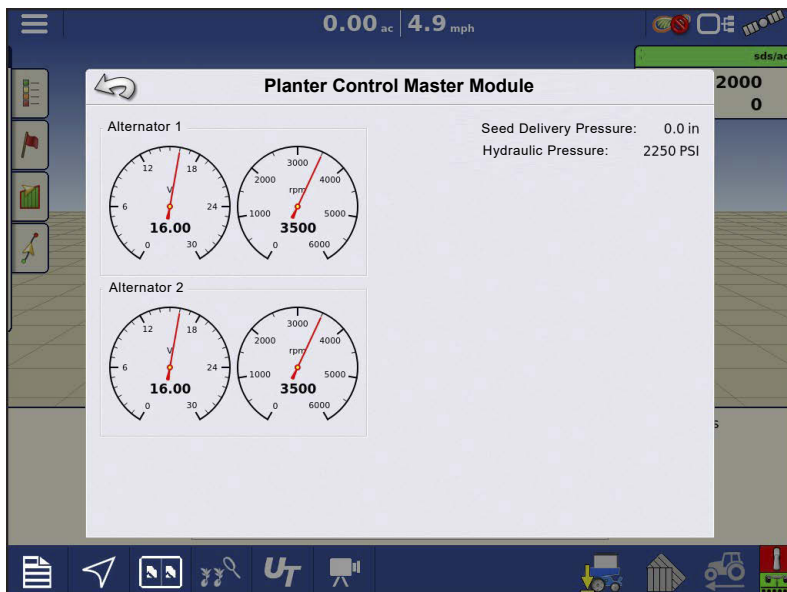

Pressing on the CAN button, located in the upper right corner of the display, opens the **Devices** screen. Highlight the **Planter Control Master Module** in the CAN B tab and press the **Diagnostics** button in the lower right-hand corner. Technical support may request that you look at these screens for help in diagnosing a problem.

In this screen you can view the current **Hydraulic Pressure**. This is the input pressure to the valve block.



## Down Force Alarms

### Down Force Inadequate

System hydraulic pressure is at maximum pressure, but the Down Force system is not achieving acceptable gauge wheel load.

**Recommendation**—If supplemental force is at maximum, increase Maximum Force on the Down Force setup screen.

-Planter may not weigh enough to handle field conditions - toolbar may be lifting. Verify if the toolbar is lifting by checking parallel arms while planting. If weight needs to be added to the toolbar, contact planter manufacturer.

### Low Gauge Wheel Load

Down force system does not achieve acceptable gauge wheel load

User defined alarm to signal operator if planter is losing planting depth.

### Hydraulic Pressure too low

Down force system commanding more down force but hydraulics are not reacting

#### Recommendations:

- Check tractor remote is on
- Check that enough hydraulic fluid is directed to down force system

### Pressure Sensor Failure

**Problem**—Pressure sensor is outside voltage range.

**Resolution**—Disable the pressure sensor to eliminate alarm until it can be replaced.

### Gauge wheel sensor types do not match. Please reconfigure.

- The Gauge Wheel Sensor selection in the Down Force settings General tab, does not match the sensor type installed on the planter.
- One or more Row Control Modules are not detecting the gauge wheel sensor.
- One or more Row Control Modules have an incorrectly set gauge wheel sensor type.

#### Recommendations:

- Verify type or part number of the gauge wheel sensor installed matches the Gauge Wheel Sensor setting
- Verify all sensors are plugged in.



- 
- Inspect cabling and connections on Row Control Module I/O cable.
  - Set Gauge Wheel Sensor to a different type, accept this type by pressing the green check mark and returning to the map screen. Re-enter Down Force settings and change the Gauge Wheel Sensor back to the correct type.



**ATTENTION!** If Gauge Wheel Sensor are not installed on every row, be sure to enter the Down Force settings Advanced tab and Disable the Load Pin on all rows that do not have a sensor.

### Planter Row Control Module Indexing Errors: Found # of #

**Problem**—When attempting to load an Event, the Configuration Selection screen

displays a  next to the configuration name. There is a  next to Planter Row Control Modules (RCM). Not all RCM's have been detected.

**Resolution:**

- Verify that the second number matches the number of planter rows.
- Next inspect the installation of the RCM's and the cabling Local CAN BUS.
- Verify all 3 lights on each RCM are green. LED #2 will be OFF if SureDrive® is not configured.
- Inspect Local CAN terminators.

For Indexing Error Screens, see [Planter Row Control Module-Indexing Error Screens on page 373](#).

### How to use Manual Override



Manual Override of the control valve may be needed if all electronic control of the Down Force System is lost, or the display becomes unusable. Manual Override allows the Down Force system to apply a constant force in order to achieve planting depth (similar to down force springs). If the need arises to put the control valve into Manual Override, follow these steps.

Steps:

1. Engage hydraulics for the Down Force system.

## Hydraulic Down Force–Individual Row

2. Locate the Down Force control valve. Unplug the 2-pin connection that's plugged into the problematic channel(s). (Connections are plugged into each channels PWM valve.)
3. Locate the allen head adjustments (3/16 inch) above electronic PWM valve.



**ATTENTION!:** For the next step you will need a quick-connect pressure gauge to measure the pressure being sent to each channel. (Ag Leader Hydraulic Test Gauge Kit PN 4100164).

4. Connect pressure gauge to the quick connect port on the back of the valve block. Port will be located under each control channel's hose.



5. Screw the allen head adjustment IN to increase pressure sent to actuators; screw OUT to decrease pressure.

Pressure (PSI) sent to actuators is shown on the pressure gauge.

6. Refer to the table below and note the Hydraulic Pressure to Down Force Conversion ratio. Multiply this value by the desired down force; this will give you the appropriate pressure to adjust the valve to.

Force Conversions	
Parallel Linkage	Pressure Conversion
Deere Short Arm	4.5 psi/lb
Deere Long Arm	3.8 psi/lb
Kinze 3000	4.2 psi/lb
Kinze 4000	5.1 psi/lb
White 8000/9000	4.8 psi/lb
Case 1200	4.5 psi/lb

Example: Kinze 3000 planter = 4.2 PSI/lb. The desired down force is 250 lbs.

---

4.2 PSI/lb x 250 lbs = **1050 PSI.**

## **FAQ**

-What should be input hydraulic pressure (PSI) be set at?

2500 to 3000 PSI (with the vehicle hydraulic source set to max flow)

-Where do I plug in an implement switch(s)?

Into the Implement Switch Module(s).

-What if I don't have any free SCV connections for the down force valve?

Teeing into existing lines is acceptable. Do not tee into the vacuum fan line if adjusting fan RPM on the tractor with a knob or dial. Teeing into the line before a flow limiter on the planter would be acceptable. Teeing into the hydraulic drive supply line would be the best option. Do not tee into Rawson Drive supply line.

-What if my hydraulic actuator does not extend far enough to reach the lower bracket with row unit at bottom travel?

Purchase one Actuator Spacer Kit per row. This will install at the bottom of the ram.  
(Commonly used on John Deere long parallel arms)

-My Kinze 3000 planter has rows that are offset 4" back, causing the upper actuator bracket to not line up with the lower actuator bracket.

Purchase one spacer kit (P/N 4101204) per row. This will move the upper bracket 4" rearward.

-Why is the gauge wheel load bar graph constantly spiking and then going to 0?

This can happen if control channel lines are routed incorrectly. Ensure channel components (hydraulic hoses, control valve cable, gauge wheel sensor wiring) are installed per the instructions.

-Why does the system need 3 hydraulic lines (Pressure, Return and Tank)

Under normal operation, pressure in the down force system is increased through the Pressure line and relieved through the Return line. When the planter runs over a terrace or a water way, the excess pressure is released through the Tank line. All three lines MUST be connected.

# Hydraulic Down Force—Individual Row

---

-What happens if my Pressure and Return hoses are connected backwards on my Hydraulic Down Force valve block?

If the Pressure and Return hoses are connected backwards on the Hydraulic Down Force valve block, the hydraulic flow will be sent directly to the channels connected to the valve block. Once this happens, the actuators on all of the channels will be applying max supplemental force. On the screen of the controlling display, this may likely result in very high gauge wheel load. This will occur on all variations of valve blocks that Ag Leader supports.

-What is a CAN Repeater Module; and when is it required?

A CAN Repeater Module is a component that is used on Ag Leaders Individual Row Hydraulic Down Force and SureDrive systems. It is only installed on systems with a Local CANBUS that exceeds a certain length. The modules purpose is to “repeat” CAN messages on these longer BUS lines to ensure communication between all of the modules connected. Ag Leader will supply the CAN Repeater Module in appropriate kits as needed.

-Can an open-center tractor be used for Ag Leaders Hydraulic Down Force?

Open-center tractors are not recommended for use with Ag Leaders Hydraulic Down Force.

## Troubleshooting

**Problem**—Down Force will not adjust in Auto Control while planting (Down Force Holds)

- Down Force indicator arrow stays Yellow while planting.

**Solution:**

- Verify implement switch(s) polarity is correct.
  - Verify implement switch(s) are tripping when planter is lowered.
1. With planter lowered, verify implement switch(s) have tripped.
  2. Check the polarity of the implement switch is correct. Implement switches can be swapped from Normally Open to Normally Closed by switching 3-pin weatherpack connections.
  3. On the implement switch module, verify the indicator light turns blue on the module when the switch is tripped to the planting position.
  4. Check mounting of implement switch(s).

- 
5. While operating Down Force, verify the toolbar is not lifting causing the implement switch to trip.

**Problem**—Supplemental Force and Gauge Wheel Load do not appear to reflect each others responses. (Ex: High Gauge Wheel Load on Row 1, with very little Supplemental Force being applied, or vice versa)

**Solution**—Verify installation of the Local CAN terminators.

1. The Local CAN is the communication wiring bus that transfers the gauge wheel load readings to the main control module. There needs to be a terminator on each end of this bus.
2. Terminator PN 4002870 will need to be installed on the wiring harness closest to row 1. Terminator 4002871 will need to be installed on the wiring harness closest to the end of the planter (right-hand side when looking at planter from the rear)

## Implement Switch Adjustment Problems

**Problem A**—Down Force is too high at the beginning of a pass after the planter has been raised.

This problem can be caused by the implement switch tripping too late when the planter is being raised. If a row with a gauge wheel sensor comes off the ground before the implement switch trips, there is the chance the sensor will register no gauge wheel load and the system will react to it and apply down force. Once the switch trips, this higher down force is now held. When the planter resumes, down force may be initially excessive until it can relieve pressure.

**Solution**—Verify that InCommand™ display firmware is version 3.0 or higher and RCM firmware is version 1.5 or higher. Adjust the implement switch mounting so that it trips sooner when raising the planter. This will allow the system to hold the appropriate amount of down force.

**Problem B**—Low gauge wheel load is witnessed on a row causing the system to apply Max down force; but after inspection of the seed trench, the problem row appears to be receiving adequate gauge wheel load.

This problem can be caused by the implement switch tripping too late when the planter is being lowered. (Ex: 50 lbs of actual load may be displayed as 0 lbs). The down force system

## Hydraulic Down Force—Individual Row

will detect the “lower gauge wheel load” and react to it by applying more down force until the sensor reaches an acceptable load.

**Solution**—Verify that InCommand™ display firmware is version 3.0 or higher and RCM firmware is version 1.5 or higher. Raise the planter to allow the sensors to re-zero with no load on the gauge wheels. Adjust the implement switch so that it trips sooner when lowering the planter. This will prevent the false gauge wheel load readings.

### Module Diagnostic Lights

#### Planter Control Module (PCM)



⊕ **High Power** – Indicates ECU power (12V) to the module.

Status	Definition
OFF	No Power
Blinking Yellow	Firmware Upgrading
Solid Green	High Power OK

1. Local CAN – Indicates if the PCM is communicating with the RCM's.

2. Display CAN – Indicates if the PCM is communicating with the controlling display.

Status	Definition
OFF	No CAN Communication
Solid Red	CAN BUS Off
Solid/Blinking Yellow	CAN BUS Error
Blinking Green	CAN BUS Communicating

#### Row Control Module (RCM)

⊕ **High Power** – Indicates high power (12V) to the module.

Status	Definition
OFF	No Power
Blinking Red	RCM Indexing
Solid Red	Low Voltage
Solid Green	High Power OK

1. Local CAN – Indicates if the RCM is communicating with the PCM.
2. Display CAN – Indicates if the RCM is communicating with the Motor Driver.

**i** **NOTE!:** LED #2 will be OFF if SureDrives are not configured.

Status	Definition
OFF	No CAN Communication
Solid Red	CAN BUS Off
Solid/Blinking Yellow	CAN BUS Error
Blinking Green	CAN BUS Communicating

### Implement Switch Module



#### Left LED

Status	Definition
OFF	No CAN Communication
Solid Red	CAN BUS Off
Solid/Blinking Yellow	CAN BUS Error
Blinking Green	CAN BUS Communicating

#### Right LED

Status	Definition
OFF	Planter Raised
Solid Blue	Planter Lowered

### Implement Switch Status Indicator





# Hydraulic Down Force–Individual Row

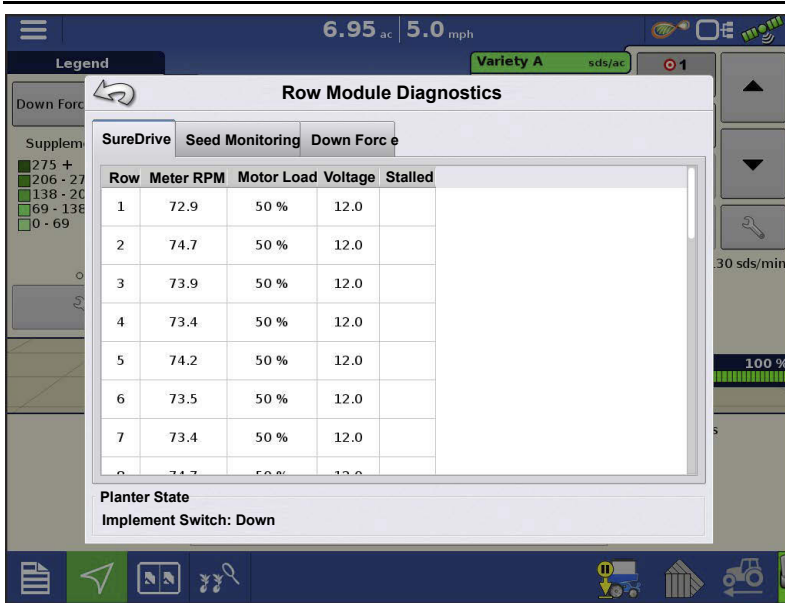

Highlight a Row Control Module in the CAN B tab and press the Diagnostics button in the lower right-hand corner to view the implement switch status.

## Planter Row Control Module-Indexing Error Screens



All modules have been detected on the CAN bus but there is an indexing issue.



There are more modules on the CAN bus than what the config requires.



There is an actual Split Row Mismatch due to a bad jumper in one of the interplant row modules.

## Hydraulic Down Force–Individual Row



All RCM modules have been found on the CAN Bus, properly indexed, and properly assigned to each of the rows.



## Ag Leader Seed Tube Monitoring Module

### Load Configuration



Press the Planting App from the home screen. This will take you through the steps needed to load a configuration.

### Map View

Once a configuration has been completed, the Map View screen appears.

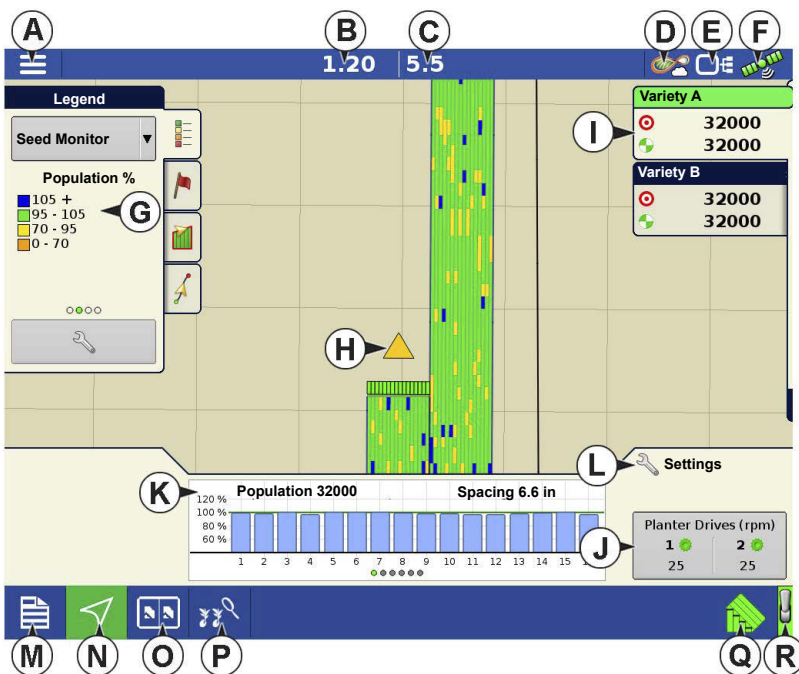

- A.Menu button
- B.Total Logged Field Area
- C.Ground Speed
- D.AgFiniti® Status
- E.Diagnostics
- F.GPS Signal Indicator
- G.Display Legend
- H.Vehicle Icon
- I.Product Control toolbox
- J.Bar Graph
- K.Settings button

L. Event Summary

M. Map View

N. Split screen

O. Advanced Seed Monitoring

P. AutoSwath

Q. Master Switch Status



**NOTE!:** Pressing the Map View button will cycle between the available Map Screen views, and the appearance of the Map View button changes.

---

## Advanced Seed Monitoring

### Bar Graph

Swiping left or right will toggle the bar graph between all the following seed placement performance graphs.

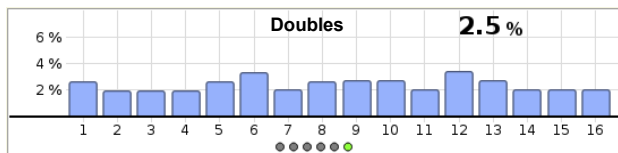
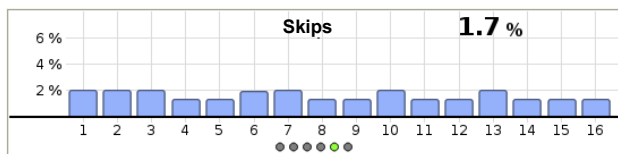
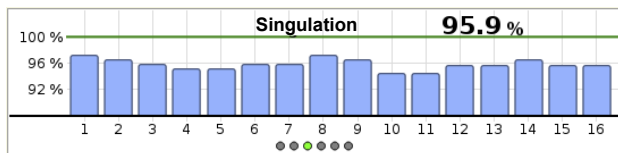
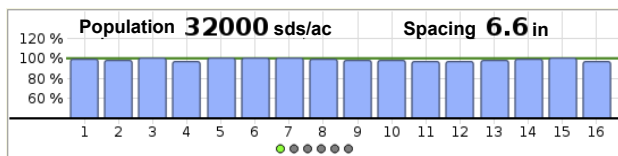

## Advanced Seed Monitoring



Press: Advanced Seed Monitoring button

## Planter Performance screen

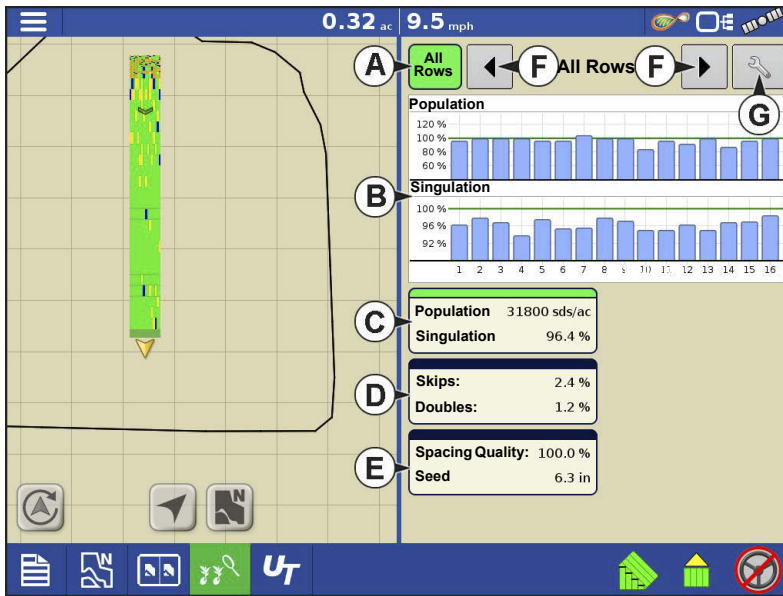

- A. All Rows
- B. Bar Graph
- C. Population/Singulation
- D. Skips/Doubles
- E. Spacing Quality/Seed Spacing
- F. Previous/Next Row Toggle
- G. Seed Monitor Options

Advanced Seed Monitoring provides planter performance monitoring of seed meter singulation, skips/doubles and spacing quality, along with population and spacing information for all rows when planting compatible crops.

In addition, Advanced Seed Monitoring automatically determines and displays the rows operating at the highest and lowest levels for singulation and population. The screen also shows the averages for specific drive sections.

Bar graph can show individual row information for the averages shown on buttons (C, D, E, G, H).

Bar graph can show individual row information for the averages shown on buttons (C, D, E, G, H).

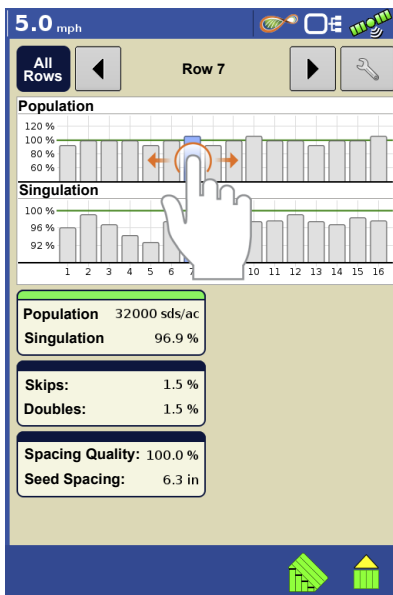

**A. All Rows**—Planter average for display items (C, D, E, G, H) at the bottom of the screen.

**B. Bar Graph**—Displays population, singulation, spacing quality, skips, and doubles, as selected by the operator.



**NOTE!** An operator may also touch the appropriate bar on the graph to show that specific rows Advanced Seed Monitoring values. To easily change between specific rows, tap and hold your finger on the bar graph, then drag left or right between rows. Release your finger from the screen when the desired row is highlighted.

---

C. **Population**—Displays the average population for the planter, or sections of the planter, along with the highest and lowest population row.

D. **Skips/Doubles**—Displays the average skips and doubles for the planter

- Skips are a measure of the percentage of seed expected to be planted that are not due to a seed not being dropped by the seed meter.
- Doubles are a measure of the percentage of seed expected to be planted individually but instead two or more are dropped by the seed meter.

E. **Singulation**—Displays the average Singulation for the planter, or selected sections of the planter, along with the highest and lowest rows.

- Singulation is a measure of the percent of seeds being properly metered so that one and only one seed drops from each seed cell of the seed meter.

F. **Spacing Quality**—Displays the average spacing quality for the planter, or selected sections of the planter, along with the highest and lowest.

- Spacing quality is a measure of the percent of seeds being properly placed so that the spacing is as expected in the seed trench.

G. **Previous/Next Row Toggle**—Toggle through the rows using the arrow buttons or press on a specific row in the bar graph to show specific Advanced Seed Monitoring values for that row.



H. **Seed Monitor Setup**—Pressing this button brings up Seed Monitor Options screen.



**NOTE!** If you are receiving Double, Skip, or Poor Spacing indicators while planting, refer to [Singulation Errors](#) on [page 391](#).

## Creating Products

Creating planting products can be completed during initial setup or from the Product Selection screen of the Field Operation Wizard when starting a field operation.

Follow described steps to create planting varieties during initial setup.





1. Select **Product Type** (Crop) and **Product Units** (seeds or pounds).
2. Enter **Variety** or **Hybrid** name.

Press  to enter a unique name for the variety or hybrid.

3. Enter **Variety** or **Hybrid Manufacturer** is applicable.

Manufacturer name can be added to the drop-down menu by pressing .

4. Press  to complete Product setup.

Created variety or hybrid should appear under the Planting heading located on the Product tab of the Configuration Setup Screen.

## Create Configuration

A wizard will guide you through the process of selecting or creating a configuration with application settings.

The configuration can be started in two places:



OR

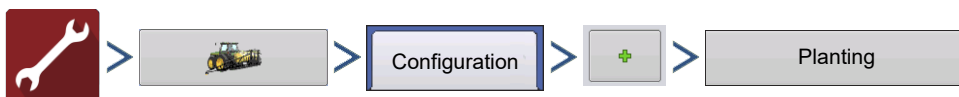



Your Operating Configuration will then be viewable when you start a new Field Operation.

You can also use the **Manage Equipment** button to create or edit specific vehicles and implements.

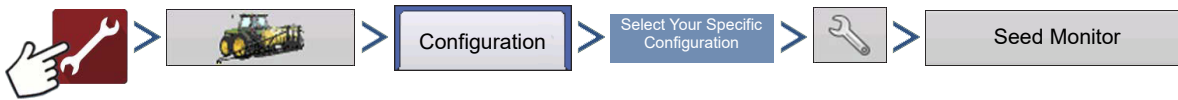
## Seed Monitor Setup



- The **Split Rows** and **Standard Rows** settings show the number of rows found on the planter that the Ag Leader Seed Tube Monitoring Module supports. Use  /  to enter the total number of rows found on the planter.
- The **Speed Source** shows the selected Ground Speed Source input for the Ag Leader Seed Tube Monitoring Module.
  - GPS: The STMM utilizes the speed from the GPS correction source that is connected to the display.
  - AUX: The STMM utilizes a speed source that is connected to the Auxiliary Input Module. This is typically a tractor wheel speed or radar source.
- Press **Sensor Configuration** to summon the Sensor Configuration window, which shows which rows are assigned to the individual pins on the Ag Leader Seed Tube Monitoring Module.



**NOTE!:** Press Sensor Configuration to perform the **AutoConfig** procedure, which is necessary for a Ag Leader Seed Tube Monitoring Module configuration to become active.

- Press the **Alarms** button to summon the Seed Monitor Alarms screen, which shows each row and the alarm threshold for that row.

## AutoConfig Procedure

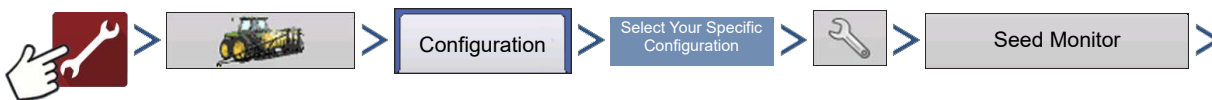

Sensor Configuration

# Ag Leader Seed Tube Monitoring Module

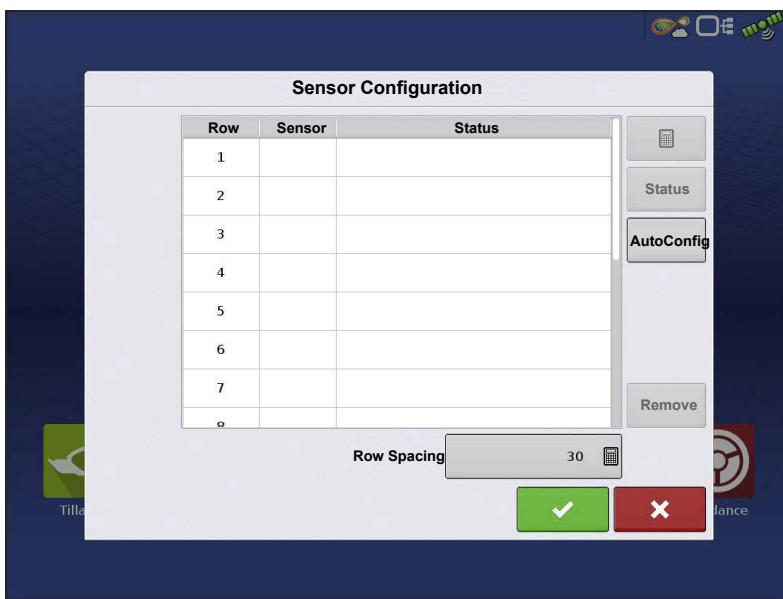

The Sensor Configuration screen shows which rows are assigned to the individual pins on the Ag Leader Seed Tube Monitoring Module.

- The **AutoConfig** button sends the planter settings to the Ag Leader Seed Tube Monitoring Module.

-  moves the sensor to a different location, to make configuration changes for custom planting operations.



**NOTE!:** To return to the default, press the AutoConfig button.

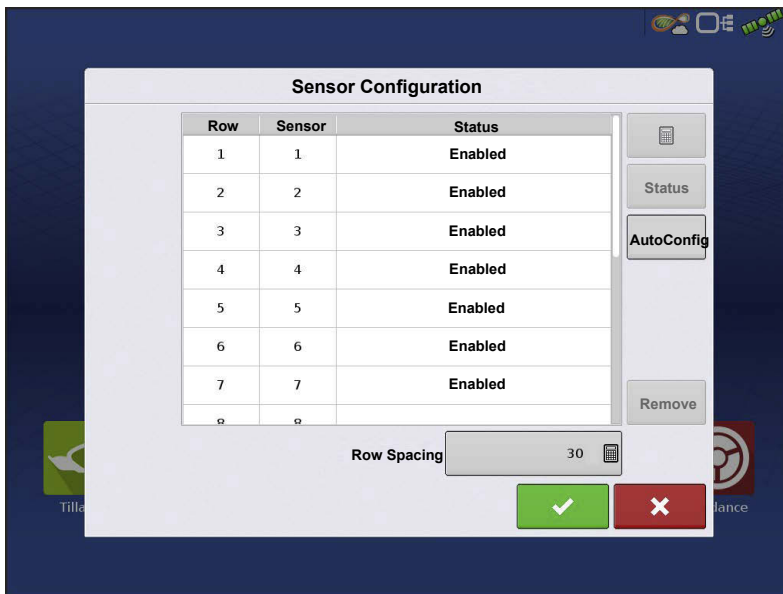

- Status**—This button Enables and Disables a Seed Tube sensor.





**NOTE!:** A row with a failed sensor can be ignored until a replacement sensor is installed.

- Remove**—This button removes an individual Seed Tube sensor.

- Row Spacing**—Use this keypad to enter in the row spacing.

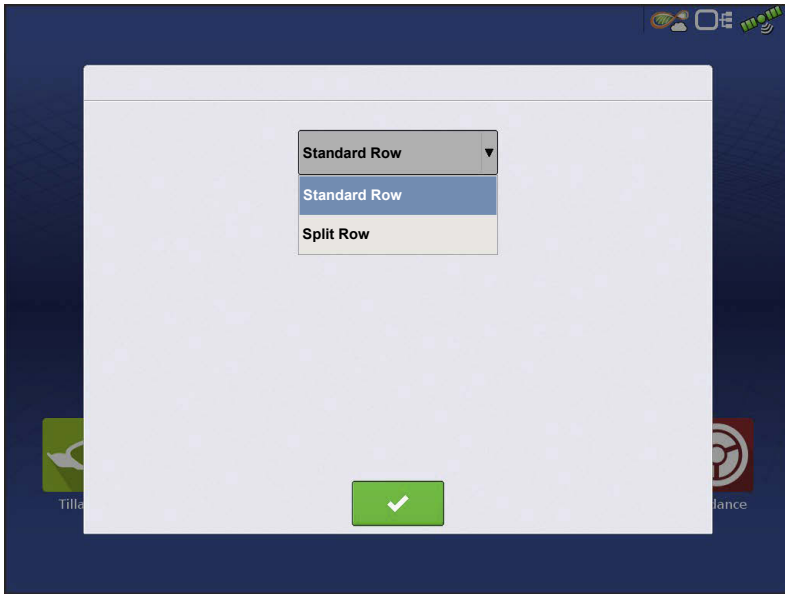
## STMM Split-Row Configurations



- If a split-row planting configuration is specified in the Seed Monitor Setup screen, then the Selection window will appear after the first time that you press the **Sensor Configuration** on the Seed Monitor Setup window. Choose between Standard Row or Split Row, and press .

- With a Split-Row Configuration the **AutoConfig Procedure** must be performed for BOTH the Standard and Split Rows. Both configurations are then saved in the display, and settings for each planting configuration are automatically applied when you specify the machine configuration at the Field Operation Wizard.

## Seed Monitor Alarms



Adjust Ag Leader Seed Tube Monitoring Module alarm thresholds. This screen can be accessed in one of two ways:

- Pressing the **Population Alarms** button at the Planter Option screen.

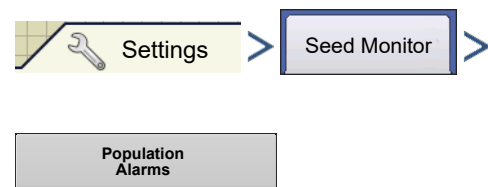

OR

- Pressing the **Population Alarms** button at the Seed Monitor Setup screen.

# Ag Leader Seed Tube Monitoring Module



- **High** and **Low** buttons assign a percentage of error that will trigger the rate alarm.
- The **Disable High** and **Disable Low** buttons deactivate the respective high or low rate alarms.
- The **Select All** button selects all rows to change the alarm threshold for the entire group.

## Planter Options

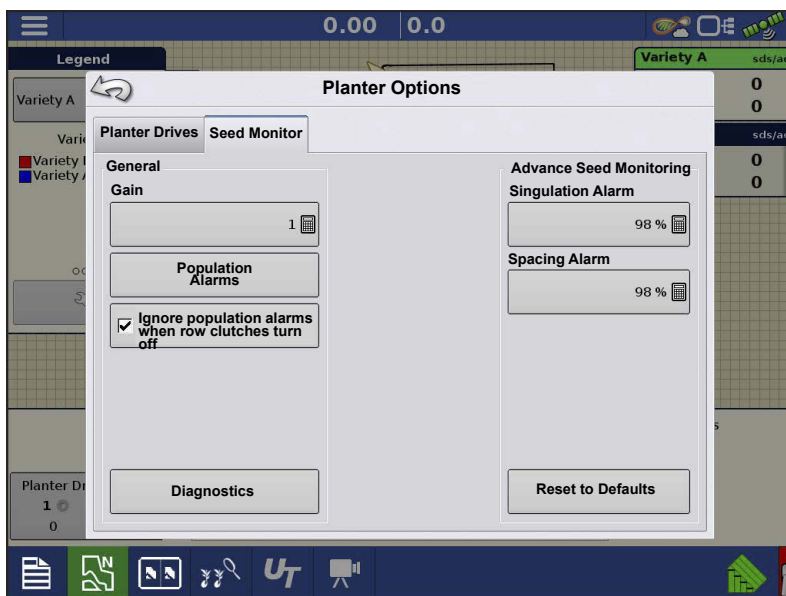

OR

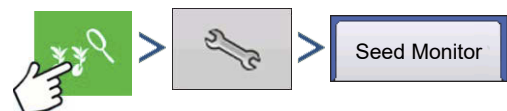

The Planter Options screen adjusts Ag Leader Seed Tube Monitoring Module alarm thresholds, Gain, and Advanced Seed Monitoring alarm thresholds. The screen also has access to module Diagnostics.

**Gain** shows the population multiplier used to adjust the population if the seed tube is not sensing the actual seed population.

- Always start with the Gain set to 1.
- Gain Setting is saved by crop type.
- For Corn, Gain values should **always** be set to 1.

**Gain adjust example:** Planting soybeans at a target population of 150,000, the on-screen population readout is 140,000. First perform a dig check to verify the correct population is being planted; then check the seed tube sensors to make sure they are clean of dust and debris. Once the checks have been done, the Gain can be adjusted so the on-screen population readout

---

reflects the true population. Divide the target population by the population readout (150,000 / 140,000 = 1.07). Enter 1.07 as the new Gain value.

### Advanced Seed Monitoring Thresholds

- Singulation Alarm
- Spacing Alarm

Crops that are supported by Advanced Seed Monitoring

- Corn
- Sorghum
- Cotton
- Sugar Beets
- Cucumber
- Vegetable (generic vegetable crop type)
- Popcorn



**NOTE!:** Advanced Seed Monitoring requires seed spacing of 3 inches or greater and seed flow of 60 sds/sec or less.



**WARNING!:** Do not change the Default Gain setting of 1 for any crops that are monitored by Advanced Seed Monitoring.



Ignore seed alarms when row clutches turned off check box

## Legend Setup

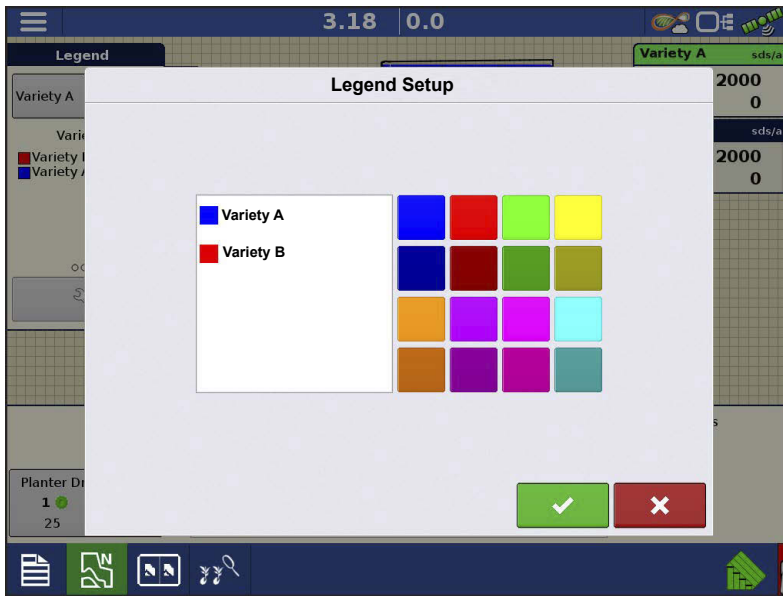

Pressing the area under the seed varieties on the Map Legend Tab of the Mapping Toolbox opens the Legend Setup screen.

If a variety was selected, a list appears on the left-hand side of the Legend Setup screen. To change the color of one of these varieties, highlight that variety and then press a color on the color palette at right. Press 

when finished.



If Seed Monitor was selected, the Legend Settings screen appears (similar to the screen to the right). Use this screen to adjust the legends thresholds. Legend settings screen may differ depending on the legend that is displayed. Press  when finished.

## Seed Monitor Diagnostics



Seed Sensors		
	seeds/second	seeds/acre
1	13	32000
2	13	32000
3	13	32000
4	13	32000
5	13	32000
6	13	32000
7	13	32000
8	13	32000
9	13	32000
10	13	32000

The **Seed Monitor Diagnostics**

screen shows row data from rows monitored by the Ag Leader Seed Tube Monitoring Module, including the following:

- Row unit seeds per second
- Row unit seeds per acre



**NOTE!** This can also be

accessed on the CAN device list under

Diagnostics



**ATTENTION!** The seeds per second column provides instantaneous feedback from the matching seed tube sensor. This feedback is not dependent on operating state. This is a useful tool for troubleshooting seed tube sensors or performing pre-season checks to verify sensor operation.

## Troubleshooting Ag Leader Seed Tube Monitoring Module

**Problem**—Receiving the warning message "The row sensor map for this configuration has not been set. Configuration not loaded."

**Solution**—The STMM map requires setup. Perform an AutoConfig. Refer to [AutoConfig Procedure](#) on [page 382](#).

**Problem**—Receiving the warning message "The number of rows in selected Operating Configuration does not match the Seed Monitor Module setup. Configuration not loaded."

**Solution**—The STMM Configuration was setup differently than the Operating Configuration.

1. Refer to the Configuraiton Setup screen for you specific vehicle/implement.



## Ag Leader Seed Tube Monitoring Module

---

2. Verify the number of rows entered in the Planting Configuration matches the number of rows entered in the Seed Monitor setup.
3. If this is a Split Row configuration, verify that "Interplant" is enabled on the Configuration Setup screen.
  - i. If it is disabled, create a new Planting Configuration and be sure to checkmark the "Split Rows Enabled" checkbox in the Implement Wizard.

**Problem**—Receiving a “Seed Monitor not Initialized” error message. Error message may be received when attempting to load an Event.

**Solution**—STMM may require a new AutoConfig.

1. Refer to the Seed Monitor setup screen.
2. Reset the number of Standard rows to a different value (ex: if the planter is a 12 row, enter 13 rows)
3. Enter the Sensor Configuration screen and press AutoConfig. Accept this sensor configuration by pressing the green check.
4. Change the Standard rows back to the correct number of rows.
5. Enter the Sensor Configuration screen and press AutoConfig. Accept this sensor configuratin by pressing the green check.
6. Attempt to load the Event.

**Problem**—Not receiving population readings from all or certain planter rows.

**Solution:**

1. Refer to the STMM Diagnostics page. Verify there is no feedback on the failed rows in the seeds per second column when seed passes by the seed sensor.
2. Check for 12V on the 2 pin duetsch connection that provides high power to the module.
3. Check for 8V on the power and ground pins on the connection that plugs into the seed tube sensor.
4. Check for 8V on the sense and ground pins on the connection that plugs into the seed tube sensor.
5. If voltages are all proper, move the seed tube sensor to a functioning row to verify it is the problematic component.



**NOTE!:** If incorrect voltage is received at any location noted above, trace down the power issue by rechecking for voltage at harness and module connection points. Refer to the Ag Leader Knowledgebase for cable schematics. Call/email Technical Support for further assistance.

## Singulation Errors

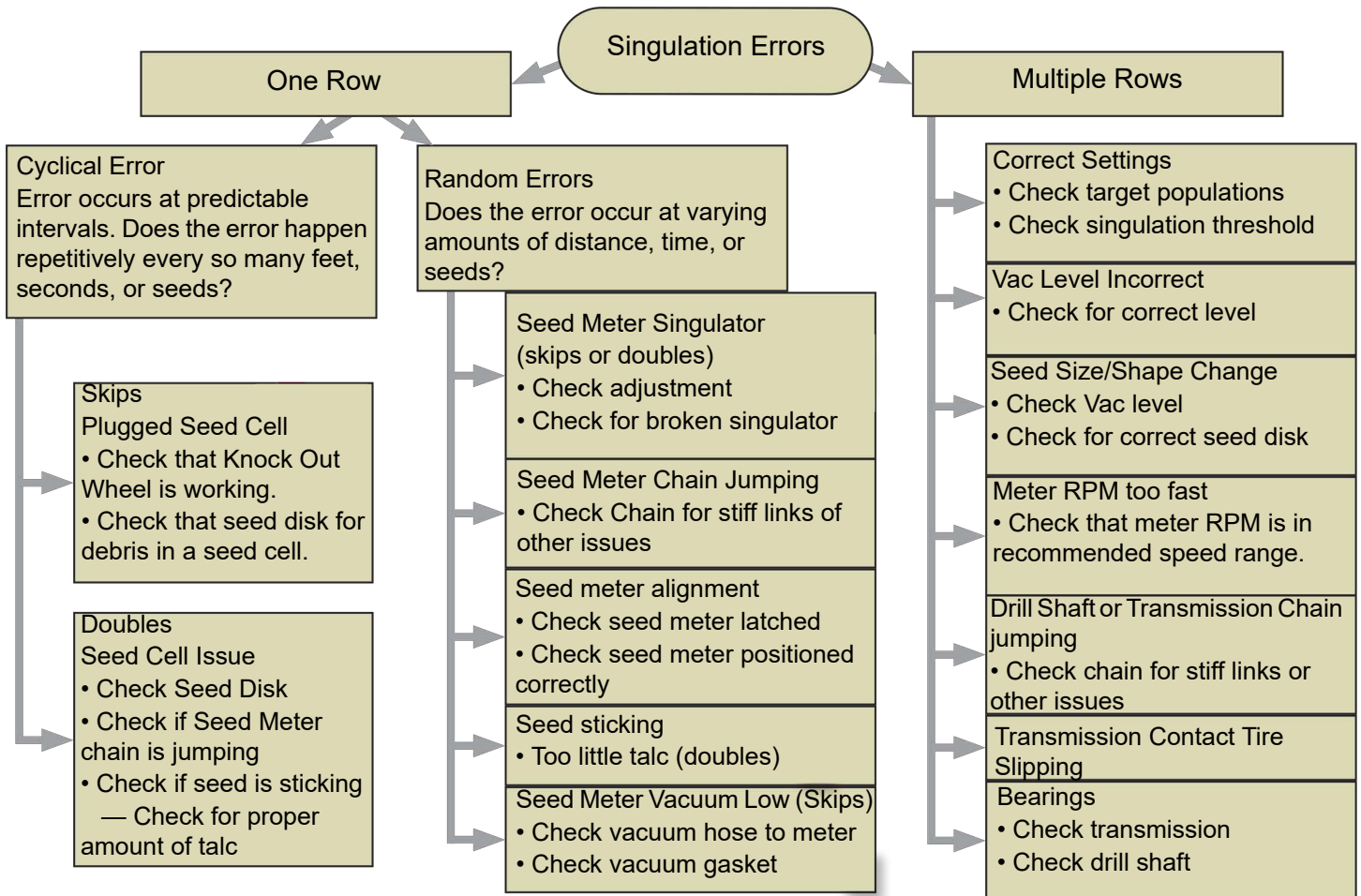

## Spacing Quality Errors

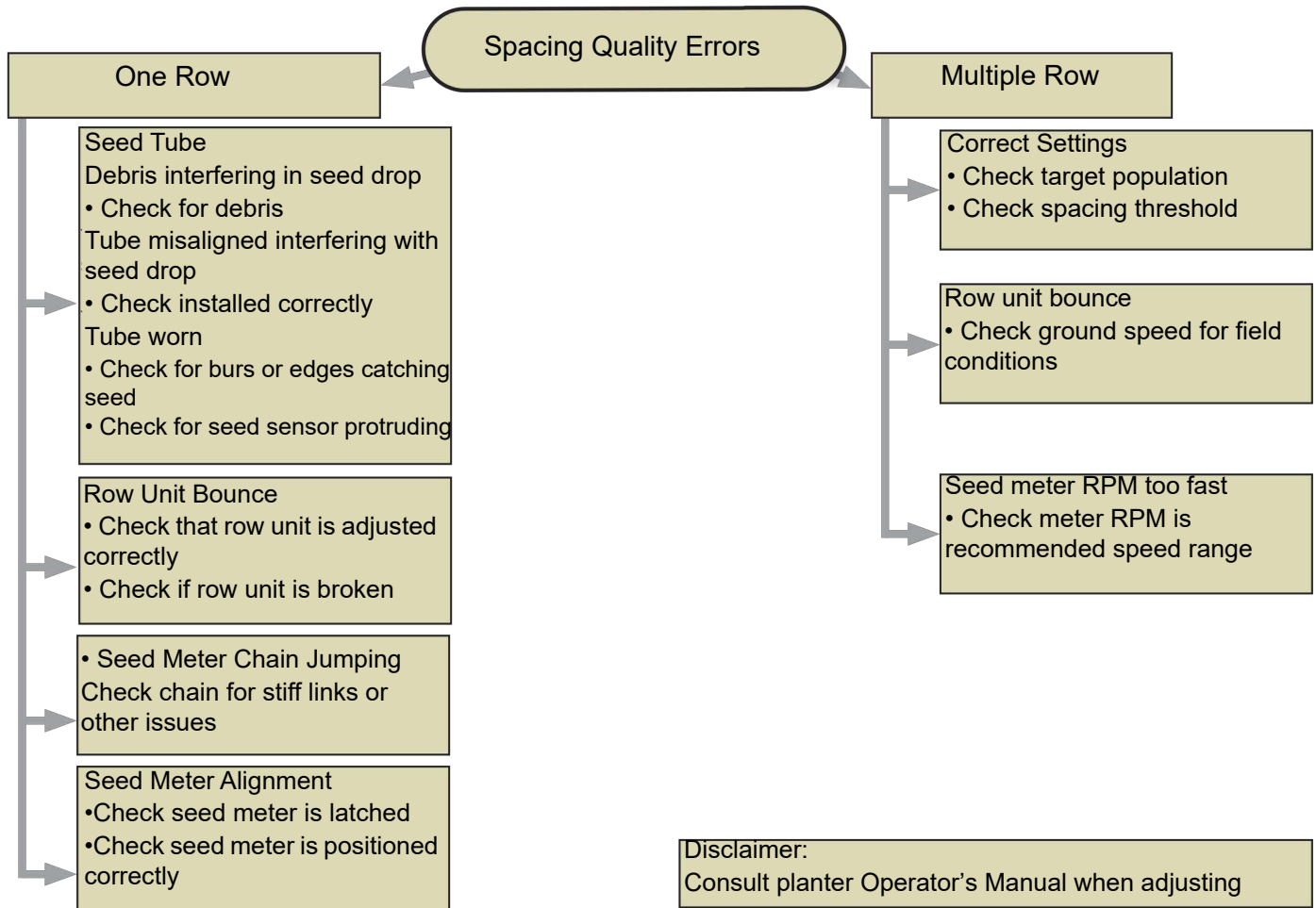



# Standard KINZE Planter Module

The Standard KINZE Planter Module is a feature that displays planting data from a KINZE Population Monitor on the Map screen.

## Load Configuration



Press the Planting App from the home screen. This will take you through the steps needed to load a configuration.

## Map View

Once a configuration has been completed, the Map View screen appears.

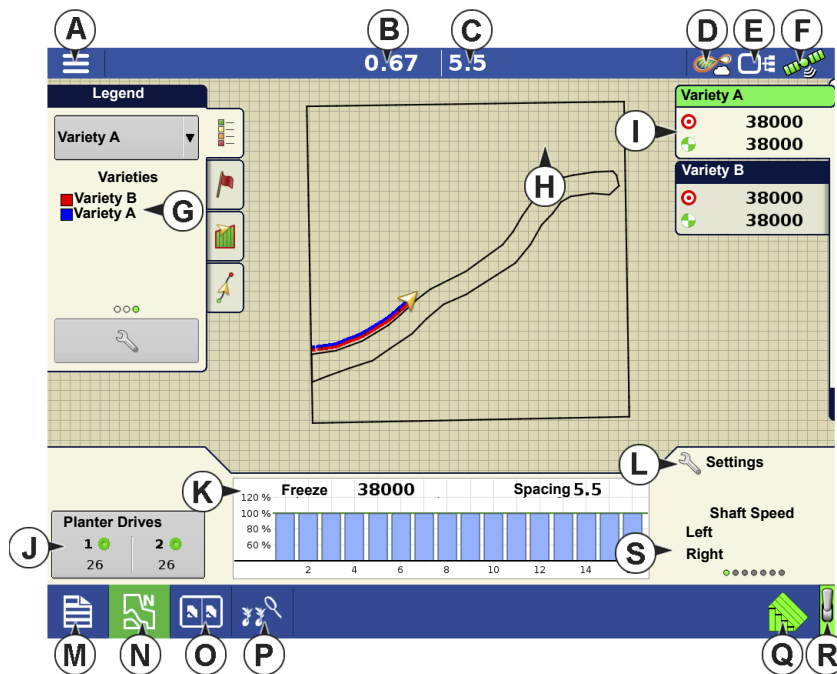

- A. Menu button
- B. Total Logged Field Area
- C. Ground Speed
- D. AgFiniti® Status
- E. Diagnostics
- F. GPS Signal Indicator
- G. Display Legend
- H. Vehicle Icon
- I. Product Control toolbox
- J. Planter Drive RPM
- K. Bar Graph

- L. Settings button
- M. Event Summary
- N. Map View
- O. Split screen
- P. Planter Performance screen
- Q. AutoSwath
- R. Master Switch Status

---

## S. Shaft Speed



**NOTE!:** Pressing the Map View button will cycle between the available Map Screen views, and the appearance of the Map View button changes.

## Planter Performance Screen

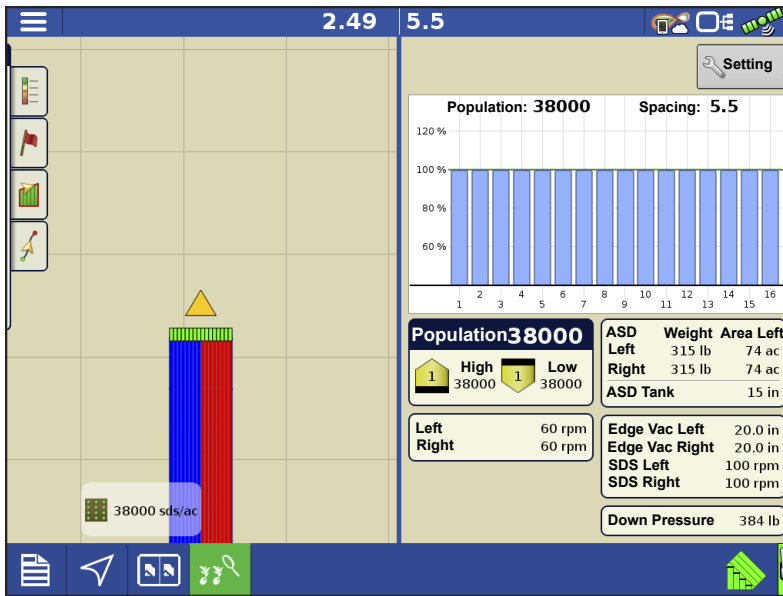

The Planter Performance screen displays information on machine performance.

**Shaft Speed**—The speed of the planter drive shafts, in RPM.

**Tank Weight**—The weight of seed in each tank of the ASD system.

**Tank Area Left**—The number of acres (hectares) that can be planted with the amount of seed remaining in the tanks of the ASD system.

**ASD Tank Pressure**—The air pressure level for the Air Seed Delivery (ASD) system.

**EdgeVac Level**—Measure of seed meter vacuum. This measurement, shown in inches of water, is displayed for each vacuum fan.

**Pneumatic Down Pressure**—Measure of down force the air bag places on the row unit.

**Magnetic Pickup Speed**—Speed registered according to the magnetic pickup.



**NOTE!**: Seed tube sensors that communicate on the MUXBUS with Planter Monitor Module can calculate each individual rows population. The PMM calculates the target population (100% line on population bar graph) by averaging each individual rows population across the planter.

## Creating Products

Creating planting products can be completed during initial setup or from the Product Selection screen of the Field Operation Wizard when starting a field operation.

Follow described steps to create planting varieties during initial setup.



---

1. Select **Product Type** (Crop) and **Product Units** (seeds or pounds)

2. Enter **Variety** or **Hybrid** name.

Press  to enter a unique name for the variety or hybrid.

3. Enter **Variety** or **Hybrid Manufacturer** is applicable.

Manufacturer name can be added to the drop-down menu by pressing .

4. Press  to complete Product setup.

Created variety or hybrid should appear under the Planting heading located on the Product tab of the Configuration Setup Screen.

## Setup Steps



**NOTE!** Steps 1-4 must be performed by everyone who has purchased a Standard KINZE Planter Monitor; steps 5-6 are performed by customers who have purchased those specific features.

1. **Standard KINZE Planter Module Configuration**—This creates a configuration that is used for Standard KINZE Planter Module operations. See [Create Configuration on page 397](#).
2. **Monitor Module setup**—Included front and rear unit settings, Shaft RPM sensor settings, and row spacing settings. This step allows the display to detect the physical KINZE Planter devices. See [KINZE Planter Configuration on page 397](#).
3. **Sensor detection process**—This allows the display to detect the proper number of Muxbus sensors on the row units. See [Muxbus Sensor Detection on page 399](#).
4. **Set alarm thresholds**—This allows user-defined level at which the seed monitor alarms will sound. See [KINZE Seed Monitor Alarms on page 403](#).
5. **Calibrate the Magnetic Pickup Coil**—This step, which is performed by customers who have purchased the Magnetic Pickup Coil Speed Sensor allows the Monitor Module to receive data from this sensor, which measures the ground speed of the planter. See [KINZE Magnetic Coil Speed Sensor Calibration on page 404](#).



6. **EdgeVac® calibration**—This step, which is performed by customers who have purchased the EdgeVac® seed meters, allows the display to receive accurate data from the meters. See [KINZE EdgeVac Calibration on page 405](#).

## Create Configuration

A wizard will guide you through the process of selecting or creating a configuration.

The configuration can be started in two places:



OR



Your Operating Configuration will then be viewable when you start a new Field Operation with the Application Wizard.

You can also use the **Manage Equipment** button to create or edit specific vehicles and implements.

## KINZE Planter Configuration

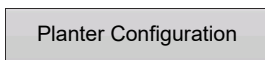

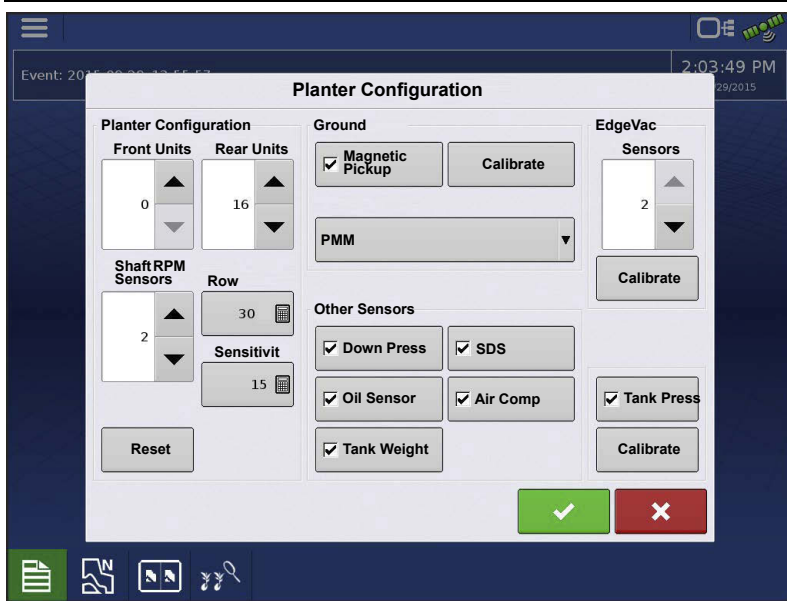

• **Front Units and Rear Units**—Use

/ to adjust the number of front and rear planting units, if necessary.

• **Shaft RPM Sensors**—Use

/ to adjust the number of Shaft RPM Sensors, if necessary.

• **Row Spacing**—Shows the minimum row spacing of the planter. Press

to adjust the Row Spacing.

- **Sensitivity**—Changes automatically with product type selection. Press to adjust.



**NOTE!** Higher sensitivity is used for smaller seeds. Default values are; Soybeans = 15 and Corn = 10. Lower sensitivity if dust is affecting displayed population.

- **Reset**—Returns settings to factory defaults, which allows operator to run Muxbus Sensor Detection again.

### Ground Speed Settings

- **Magnetic Pickup**—Check the Magnetic Pickup check box only if the planter is equipped with the Magnetic Pickup Sensor.



**NOTE!** Customers who do not have the Magnetic Pickup sensor who check this box will see a window stating “Bad Configuration: No Magnetic Pickup sensor currently found.”

- **Speed Source**—The Speed Source drop-down box selects the type of speed source for the planter monitor. Choose between GPS, AUX (Auxiliary Input Module) and PMM. This speed selection only affects the PMM. The display’s ground speed source must still be selected.



**GPS**—The PMM utilizes the speed from the GPS correction source that is connected to the display.

**AUX**—The PMM utilizes a speed source that is connected to the Auxiliary Input Module. This is typically a tractor wheel speed or radar source.

**PMM**—The PMM utilizes the Magnetic Pickup Coil that is equipped on the planter to measure speed. This coil sensor will need to be calibrated.

## Other Sensors

Other check boxes on the Planter Configuration window include:

- **Down Pressure**—Check this box if the planter has pneumatic down pressure.
- **Oil Sensor**—Leave this box unchecked.
- **SDS Sensors**—Leave this box unchecked.
- **Air Compressor**—Check this box if the planter has an air compressor installed.
- **Tank Weight**—Check this box if the planter has a tank weight sensor install.
- **EdgeVac Sensors**—Use  /  to enter the number of EdgeVac® sensors on the planter. Calibrate EdgeVac sensors once a year. To start process, press the Calibrate button.
- **Tank Pressure**—Check the box only if the planter is equipped with tank pressure sensor. Calibrate the sensor once a year. To start process, press Calibrate button.

## Muxbus Sensor Detection

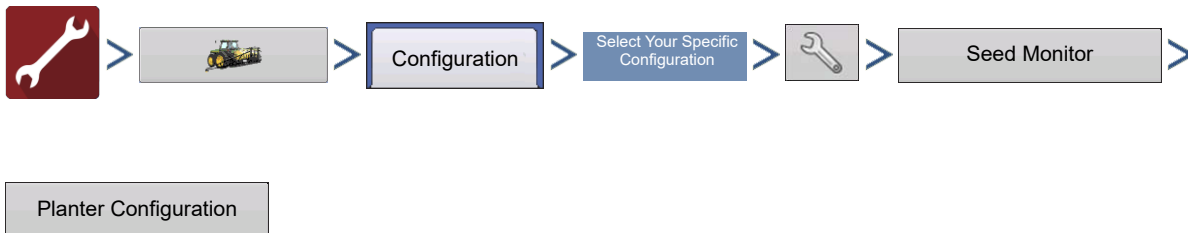

After initial configuration of the Standard KINZE Planter Module, complete the Muxbus Sensor Detection process. This process allows the Muxbus to detect each sensor on the planter. In order for the display to show the correct Planter Monitor information, complete the detection process for each Muxbus sensor.





**ATTENTION!** Be sure that all sensors are **unplugged** before beginning the process. If any sensors are plugged in the sensor harness, the Muxbus Detection process will abort. If this occurs, unplug all sensors and retry procedure.

1. To start the Sensor Muxbus Detection process, make any settings changes necessary at the Planter Configuration screen and then press . Make certain all planter sensors are disconnected from the planter harness.

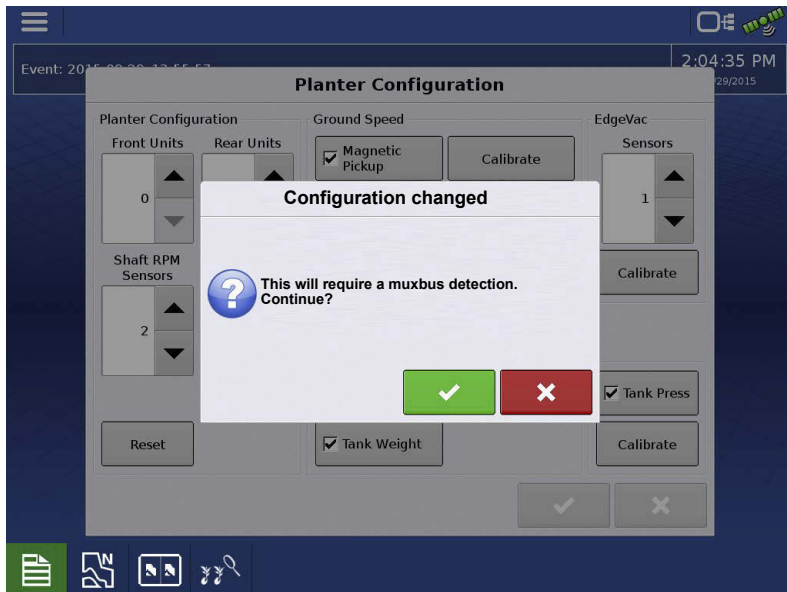

**NOTE!:** The Muxbus detection process will only start if sensor configuration has changed.



1. **Accept the Muxbus Detection**—A screen appears, informing you that your configuration has changed and that it will require a Muxbus detection. Once all sensors are disconnected, press  on the Configuration Changed screen. The Muxbus Detection Process then begins.

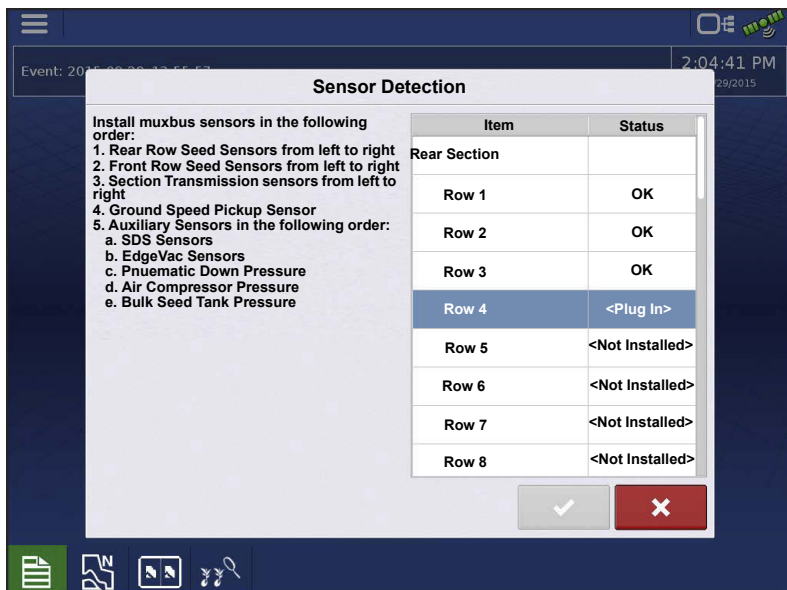

2. **Detect individual row units**—Plug in each physical sensor plug into the Muxbus wiring harness on the planter (from left to right). Follow the on-screen instructions.

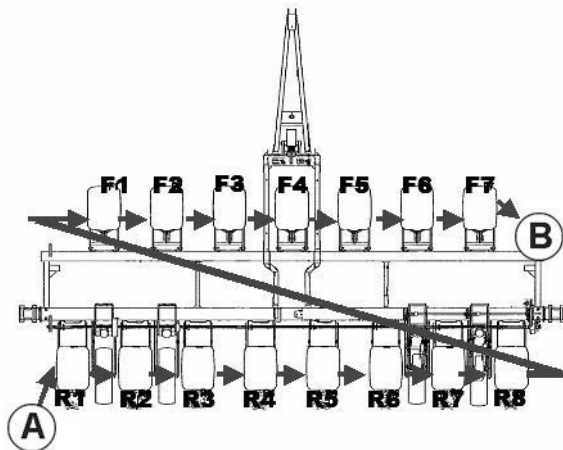

## Order of Muxbus Sensor Installation

Install the Muxbus sensors in the following order:

- Rear Row Seed sensors from left to right.
- Front Row Seed sensors from left to right.

As shown from (A) to (B).

- Section Transmission sensors from left to right.
- Ground Speed Pickup Sensor.
- Auxiliary Sensors in the following order:

- a. SDS Sensors
- b. EdgeVac® Sensors
- c. Pneumatic Down Pressure
- d. Air Compressor Sensor
- e. ASD Sensor
- f. Seed Scale Sensor

**i** **NOTE!:** When the row unit sensor is plugged in, the display will beep three times and show the status as “Calibrating.” When calibration is complete, the sensor will display either “OK” or “Slow”.

3. **Resolve Any Possible Errors**—When the Muxbus Detection Process begins, each row unit will display “Not Installed” underneath the status. But as the Muxbus Detection process takes place, each row unit should state “Calibrating” for a time, then should indicate “OK”. After calibration, the sensor status displays either one of two different states:

- OK - The sensor is working and is communicating at 9600 baud.
- Slow - The sensor is working, but is communicating at 2400 baud.

**i** **NOTE!:** Some older KPM I, II, and III systems have slower sensors with black connectors, that communicate at a 2400 baud rate. The KPM I, II and III systems with blue connectors

communicate at a 9600 baud rate. A slower baud rate does not result in decreased performance.

4. **Detect Complete**—When the Muxbus Detection process is complete, a message displays, stating “All sensors found”.

## KINZE Sensor Configuration

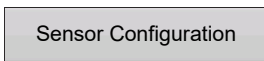

OR

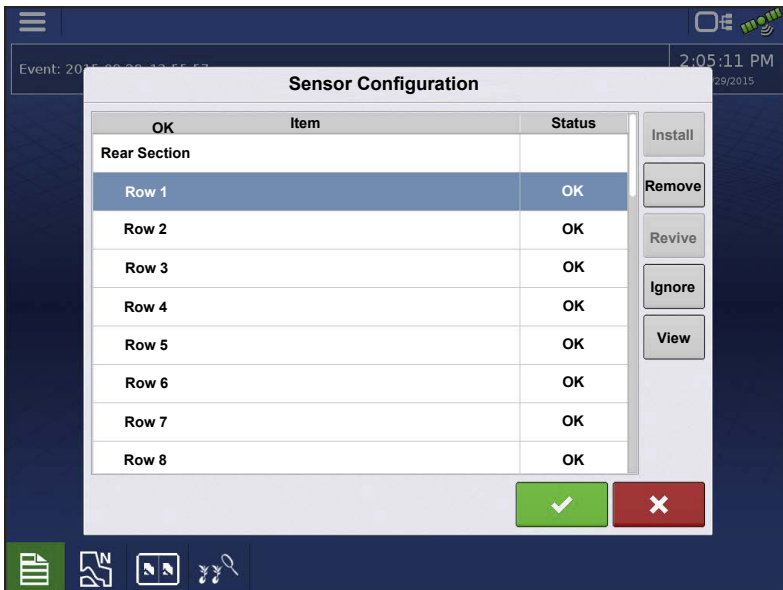

The Sensor Configuration screen is for system maintenance of the KINZE Population Monitor.

- **Install**—Installs a row sensor.
- **Remove**—Removes the highlighted sensor of any type.

**NOTE!** For steps to replace a failed sensor, refer to [Troubleshooting on page 408](#).

- **Revive**—Allows the display to reattempt communication with the highlighted sensor of any type.
- **Ignore**—Tells the display to cease communications with a row sensor.
- **View**—Shows the Sensor Information screen.

## Sensor Information

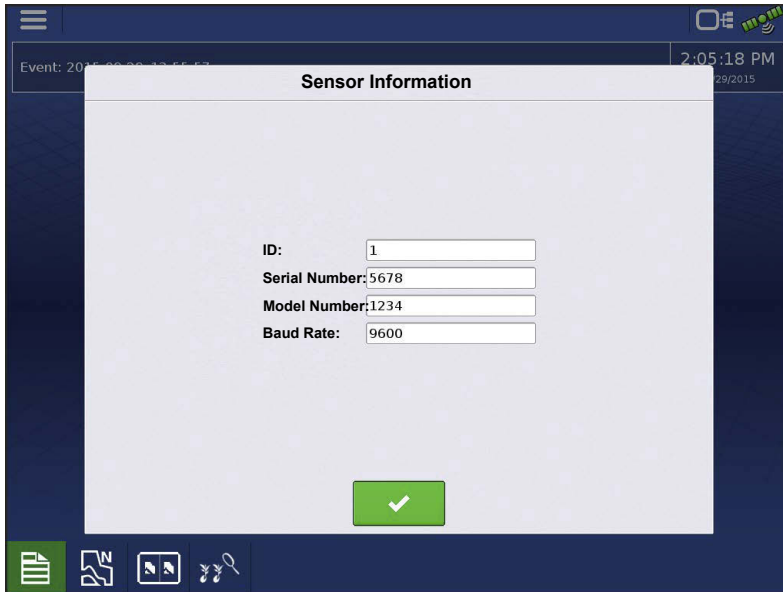
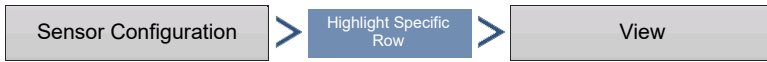

The Sensor Information screen displays hardware information for each seed tube sensor and also other sensors. Technical Support may request that you look at this window for help in diagnosing a problem.

- **ID**—A unique number for each sensor on the Muxbus.
- **Serial Number**—Varies for each individual seed tube sensor.

- **Model Number**—Shared by each unit of the same model of seed tube sensor.
- **Baud Rate**—The speed of transmission between the Muxbus sensor and the PMM module.

## KINZE Seed Monitor Alarms





To view the Seed Monitor Alarms screen, press the Alarms button on the Standard KINZE Planter Module Setup screen. To change the threshold of an alarm, highlight the row unit, then press either a given percentage number (10%, 50%, 70%, or use the  to create a value). The alarm will then sound only when the individual seed sensor population drops below that numeric threshold

value relative to the planter average population.

 **NOTE!** The default alarm setting is at 50%.

 **NOTE!** Press the Disable button to turn threshold of the alarm to zero.

## KINZE Magnetic Coil Speed Sensor Calibration

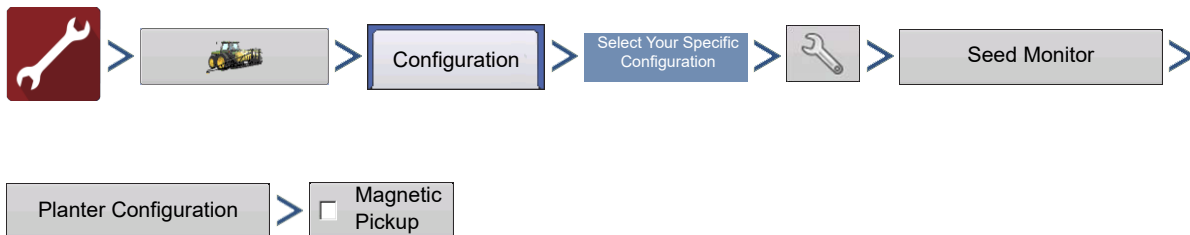

Standard KINZE Planter Module customers who have a magnetic coil speed sensor must check the Magnetic Pickup check box. This setting should then be left unchanged.



These customers will need to calibrate the Magnetic Coil Speed Sensor at least once per season. Press the Calibrate button located next to the Magnetic Pickup check box. The Magnetic Coil Speed Sensor Calibration wizard appears.

1. **Enter distance of calibration**—The default distance for calibrating the magnetic coil speed sensor is 100 feet (50 meters). If you wish to calibrate at another distance, enter the new distance. Press  to continue.



2. **Drive from start to end points**—Position the vehicle at the start marker. Press the green-colored Start button and drive the vehicle for the predetermined distance.

 **NOTE!**: The display must be set on 0.0 before driving the calibration distance.

3. **Stop at end of calibration distance**—When the vehicle crosses the end marker of the predetermined distance, press the red-colored Stop button. Press  to continue to final step.
4. **Calibration complete**—The speed sensor calibration number has been calculated from the actual distance driven. Press  to complete calibration and store the calculated value.

 **NOTE!**: Calibration settings can be manually adjusted if desired by pressing Enter CAL Number and making small changes to the setting.

## KINZE EdgeVac Calibration



### EdgeVac box

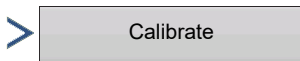

Customers who have purchased the EdgeVac® seed meters should perform an EdgeVac Calibration once a year to make sure that it is correct.

Press the Calibrate button.

Press  to enter the actual value taken from the hand-held calibration sensor at the vacuum sensor.



**NOTE!** The appearance of this screen varies, depending upon whether you have one or two EdgeVac sensors.

## Standard KINZE Planter Module Options

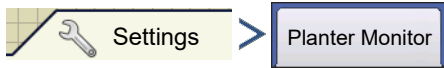

OR

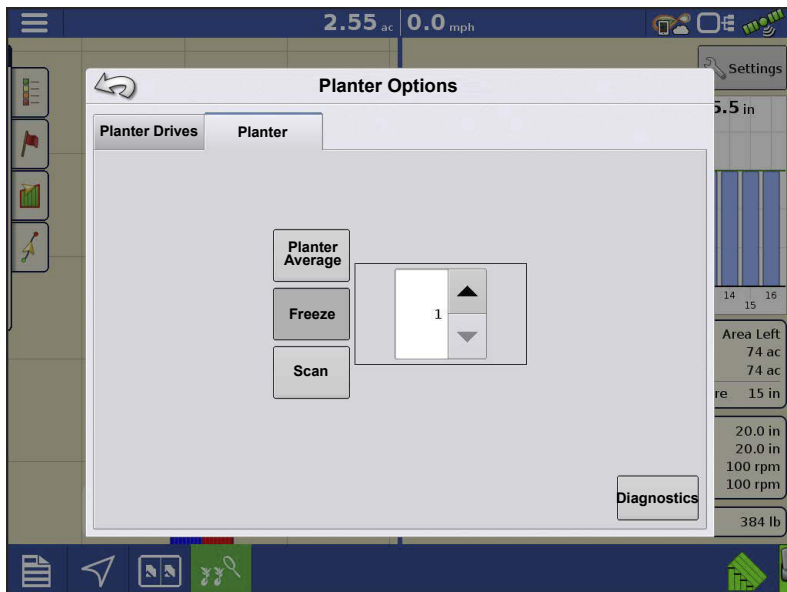
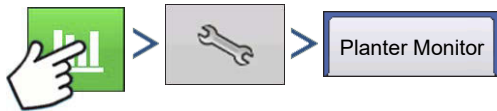

Make changes to the bar graph's rate/spacing display. Options include Planter Average, Freeze and Scan, explained below.

- **Planter Average**—Default setting for the Rate/Spacing Display. This setting specifies that the Rate/Spacing Display shows the instantaneous average population and seed spacing for the entire planter.

- **Freeze**—Specifies that the Rate/Spacing Display continuously shows only one specified row chosen by the operator.

Use  /  to specify which row to “freeze”.

- **Scan**—Specifies that the Rate/Spacing Display shows an automatic row-by-row scan on all the planter's row units, displayed in sequence from left to right.

## Planter Monitor Diagnostics



# Standard KINZE Planter Module



The Planter Monitor Diagnostics shows row data from rows monitored by the Standard KINZE Planter Module, including the following:

- Row unit seeds per second
- Row unit seeds per acre



**NOTE!:** This can also be accessed on the CAN device list under Diagnostics.

## KINZE Display Items in Map View

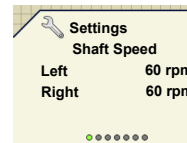
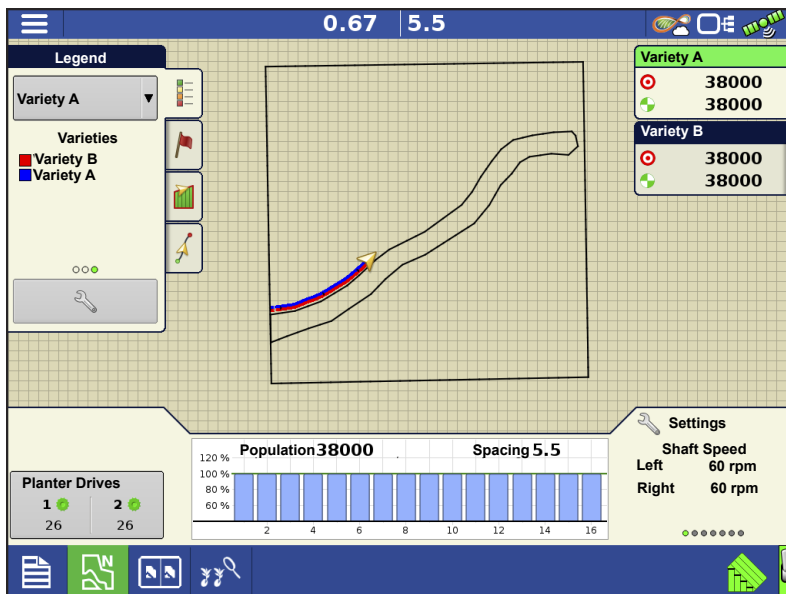

The lower right-hand side of the Mapping screen's Equipment Tab includes a number of display items that will vary depending upon the particular Standard KINZE Planter Module configuration.

Swipe displayed item shown above to cycle through sensors.

**Shaft Speed**—Speed of the planter drive shafts, in RPM.

**SDS**—Speed of the planter seed delivery system (auger), in RPM.

---

**EdgeVac Level**—Seed meter vacuum. This measurement, shown in inches of water, is displayed for each vacuum fan.

**Pneumatic Down Pressure**—Down force the air bag places on the row unit.

**Magnetic Pickup**—Speed registered according to the magnetic pickup.

**Tank Weight**—Weight of seed in each tank.

**Tank Area Left**—Acres (hectares) that can be planted with the amount of seed remaining in the tanks.

**Tank Pressure**—Air pressure level for the Air Seed Delivery (ASD) system.

## Troubleshooting

### How to replace a failed MUXBUS sensor

Follow these steps to properly replace a MUXBUS sensor. Failure to follow these steps may require the user to perform entire MUXBUS Sensor Detection.

1. If a sensor fails, leave it plugged in and installed.
2. Proceed to the Sensor Configuration screen.

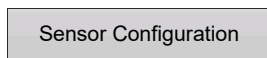

3. Select the failed sensor.
4. With the failed sensor highlighted, press the **Remove** button.
5. Proceed with unplugging and uninstalling the failed sensor.
6. Install the new sensor and plug it into the MUXBUS harness.
7. Return the Sensor Configuration screen on the display. Press the **Install** button. The sensor Status will change to **OK**.

8. Once the new sensors status changes to **OK**, the sensor replacement is complete. The process can be verified by pressing the **View** button and matching the displayed Serial Number with the physical Serial Number on the sensor label. Press .



**NOTE!:** Users can take the above steps with a lone sensor in attempt to increase the baud rate of a SLOW sensor. Depending on the style of sensor installed and the number of sensors installed on a harness, not all SLOW sensors will communicate on a higher baud rate. A SLOW sensor does not decrease performance.

### Alarms on Standard KINZE Planter Module

When the Active Alarms window is shown, scroll through the list to locate the row units where the alarm is occurring. Acknowledge the alarm by pressing . After dismissing the alarm, you may continue planting, however, the alarm will continue showing in the title bar. You may also review the Active Alarm information in the Planter Monitor Diagnostics.

The list below describes various alarms that may occur at system startup. The following pages describe errors that could occur during field operations.

**Error Message:** “Sensors calibrating wait for calibration”

**Possible Cause:** PMM startup

**Solution:** Wait for Planter Monitor Module (PMM) to finish before beginning operation.

**Error Message:** “(Row #) sensor not detected”.

**Possible Cause:** Population sensor did not begin communicating with the PMM.

**Solution:** Acknowledge the error by pressing OK. Check the LED on the sensor to see if it is working properly. If it has failed, then replace the sensor. Refer to the KINZE Planter Operator’s manual for further instructions.

**Error Message:** “Clean or replace sensor (Row #) as necessary”.

**Possible Cause:** Population sensor dirty.

**Solution:** Press OK to dismiss the error. Then clean the sensor and restart the system.

**Error Message:** “(Row #) mux bus data line short to mux bus ground”.

**Possible Cause:** Population sensor’s mux bus signal wire is shorted to ground.

**Solution:** Press OK to dismiss the error. The display then replaces the message window with an alarm text on the header bar at the top of the Run screen. This alarm

---

text continues until the wire is fixed or the sensor is disabled. Inspect the wire at the first opportunity.

**Error Message:** (Row #) mux bus data line short to mux bus power”.

**Possible Cause:** Population sensor’s mux bus signal wire is shorted to power wire.

**Solution:** Press OK to dismiss the error. The display then replaces the message window with an alarm text on the header bar at the top of the Run screen. This alarm text continues until the wire is fixed or the sensor is disabled. Inspect the wire at the first opportunity.

**Error Message:** “(Row #) communication lost”.

**Possible Cause:** Seed tube sensor stops communicating with the PMM.

**Solution:** Press OK to dismiss the error. The display then replaces the message window with an alarm text on the header bar at the top of the Run screen. This alarm text continues until the wire is fixed or the sensor is disabled. Inspect the sensor at the first opportunity.

**Error Message:** “(Inner or Outer; Right, or Left) Shaft Communication Lost”

**Possible Cause:** Transmission sensor stops communicating with the PMM.

**Solution:** Press OK to dismiss the error. The display then replaces the message window with an alarm text on the header bar at the top of the Run screen. This alarm text continues until the wire is fixed or the sensor is disabled. Inspect the sensor at the first opportunity.

**Error Message:** “(Left or Right) Edge- Vac sensor communication lost”.

**Possible Cause:** Edge-Vac sensor stops communication with the PMM.

**Solution:** Press OK to dismiss the error. The display then replaces the message window with an alarm text on the header bar at the top of the Run screen. This alarm text continues until the wire is fixed or the sensor is disabled. Inspect the sensor at the first opportunity.

**Error Message:** “(Left or Right) SDS shaft sensor communication lost”.

**Possible Cause:** SDS shaft sensor stops communicating with the PMM.

**Solution:** Press OK to dismiss the error. The display then replaces the message window with an alarm text on the header bar at the top of the Run screen. This alarm text continues until the wire is fixed or the sensor is disabled. Inspect the sensor at the first opportunity.

**Error Message:** “Low hydraulic oil level”.

**Possible Cause:** Hydraulic oil level drops.

**Solution:** Check oil level on the planter, add as necessary.

**Error Message:** “High hydraulic oil temperature”

**Possible Cause:** Hydraulic oil temperature level rises

**Solution:** Stop planter in order to cool down oil temperature. Inspect for cause of overheating.

**Error Message:** “Voltage Error Alarm”.

**Possible Cause:** Occurs if the battery voltage drops below 10 volts, or rises above 15 volts.

**Solution:** Check tractor’s electrical system.

**Error Message:** “(Row #) Seed Rate Alarm”.

**Possible Cause:** The seed rate of one or more rows is less than the alarm threshold setting and the corresponding transmission shaft sensor detects rotation.

**Solution:** Press OK to dismiss the error. If the alarm state is still present, the graph will state the rows where the errors are occurring, and the Title Bar will flash the type of alarm. Inspect row units to confirm that each has seed, and that all mechanical drive shaft parts are working properly.



**NOTE!:** If desired, the alarm threshold for the row unit may be set to 0%, which will silence the seed rate alarm. However, the bar graph will continue to operate and the row will still be calculated in the planter average population. For instructions on changing the alarm threshold, see [KINZE Seed Monitor Alarms on page 403](#).

**Error Message:** “Low Down Force Air Pressure”

**Possible Cause:** Low pressure in the pneumatic down pressure system.

**Solution:** Press OK to dismiss the error. Check for air leaks and compressor failure.

**Error Message:** “Left (or Right) Tank Seed Level Low.

**Possible Cause:** The Seed Scale weight has dropped below the entered threshold.

**Solution:** Press OK to dismiss the error. Refill the tank to clear the error completely.

**Error Message:** “Seed Tank Pressure Too Low.”

**Possible Cause:** The minimum air flow for seed delivery is not present.

**Solution:** Press OK to dismiss the error. Check fan on the ASD system.

**Error Message:** Air Compressor Sensor Too Low.”

**Possible Cause:** The minimum air compressor tank pressure is not present.

**Solution:** Press OK to dismiss the error. Check the air compressor.





The SureDrive system is an electric drive that installs directly onto a planter seed meter to control seed population, perform section control, turn compensated rate control, and a variety of other planter functions.



**NOTE!** If a planter has narrow rows (less than 30 inch row spacing) Ag Leader recommends grouping the outer planter sections together as a single swath section. Due to GPS drift, sections less than 30 inches may be turned on and off by AutoSwath™ when planting next to a covered area.

## Load Configuration



Press the Planting App from the home screen. This will take you through the steps needed to load a configuration.

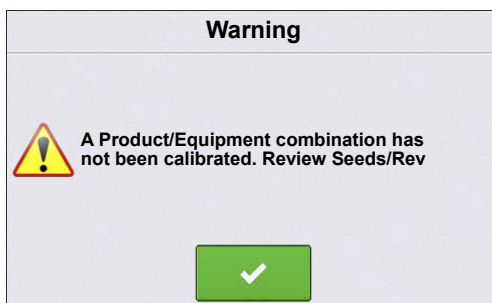

**ATTENTION!** If a configuration is loaded for the first time, the user will be presented with a warning message indicating that the Seeds/Rev setting needs to be reviewed. Proceed to the Planter Options screen to enter the appropriate Seeds/Rev value, see [Planter Options](#) on [page 424](#). The Seeds/Rev value is required in order to control the planter rate. (If the Seeds/Rev value is left at 0, this warning message will appear each time an Event is created/continued.)

## Map View

Once a configuration has been completed, the Map View screen appears.

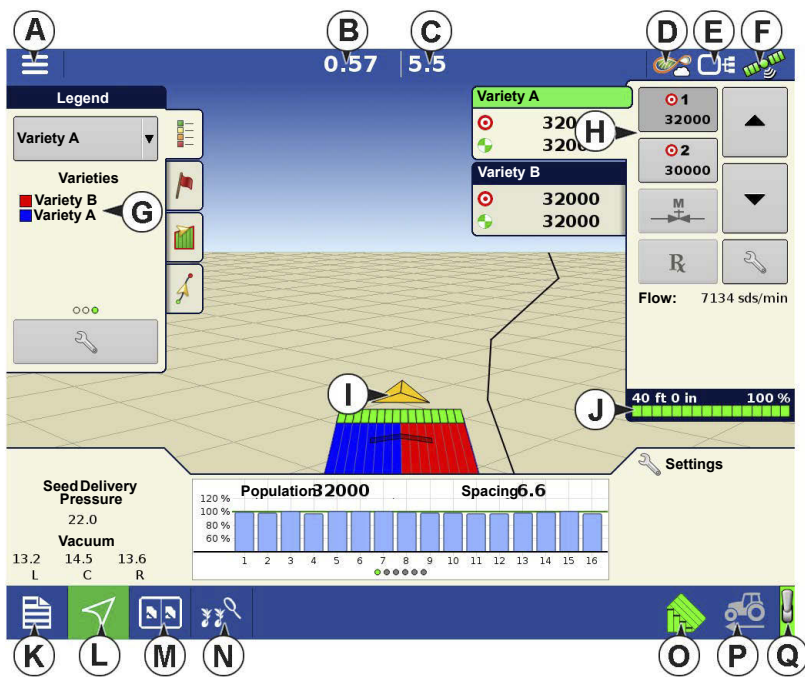

- A.Menu button
- B.Total Logged Field Area
- C.Ground Speed
- D.AgFiniti® Status
- E.Diagnostics
- F.GPS Signal Indicator
- G.Display Legend
- H.Product Control toolbox
- I.Vehicle Icon
- J.Section Status Indicator
- K.Event Summary

- L. Map View
- M. Split screen
- N. Advanced Seed Monitoring
- O. AutoSwath
- P. Jump Start
- Q. Master Switch Status

**i** **NOTE!:** Pressing the Map View button will cycle between the available Map Screen views, and the appearance of the Map View button changes.

## Product Control Toolbox

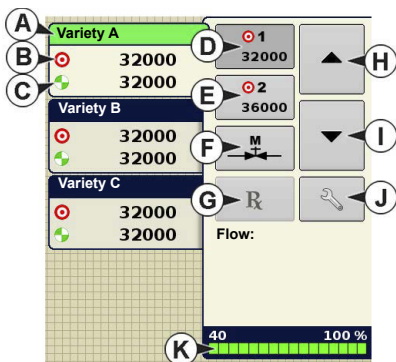

During SeedCommand® Run Time operations, the Product Tabs are shown in the upper right-hand side of the Map screen. Press the Product Tabs, and an extended view shows the Rate buttons, Manual Valve Control button, Prescription button, Rate increase and decrease arrows, and the Rate Setup button, all of which are described below.

a. **Variety**—The Product Control Toolbox can show rates for multiple varieties, depending upon the particular planting configuration. Press the area of the box that shows a particular variety, and a green bar highlights that variety. The Rate 1 and Rate 2 are then shown on the Rate buttons.



b. **Target Rate**—The Target Rate is the desired planting rate.



c. **Actual Rate**—The Actual Rate is communicated by the shaft rotation sensor.



**NOTE!:** In some conditions, the Actual Rate may increment slower than the Target Rate, or its numeric values may vary before matching the Target Rate.



d. **Rate 1 button**

e. **Rate 2 button**

The Rate 1 and Rate 2 settings represent preset planting rates that allow operators to quickly change between desired planting rates for each individual product. The active rate button appears with a gray background behind it. In the example above, Rate 1 is active.



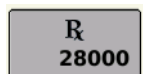

f. **Manual Rate Control button**



g. **Prescription button**

h. **Rate Increase arrow** 

i. **Rate Decrease arrow** 

Pressing once on  /  increments the rate according to the user-defined amount on the Rate Control Settings screen.









j. **Rate Setup button**—The Rate Setup button opens the Rate Control Settings screen.

k. **Section Status Indicator**

# Rate Control Settings



Press  to adjust the Rate 1 and Rate 2 settings shown at the Product Control Toolbox on the Map screen, as well as import planting prescriptions. To access the Rate Control Settings screen, press the Rate Setup button on the Product Control Toolbox. The Rate Control Settings screen appears.

- The **Rate 1** and **Rate 2** settings represent preset application rates that allow operators to quickly change between desired target rates for each individual product. Press  to enter the desired amount.
- The **Increment** button allows operators to specify the increase or decrease amounts for a specified rate when using  /  on the Product Control Toolbox. Press  to enter the desired increment.
- To load a map-based prescription file, press .

## Turn Compensated Rate Control

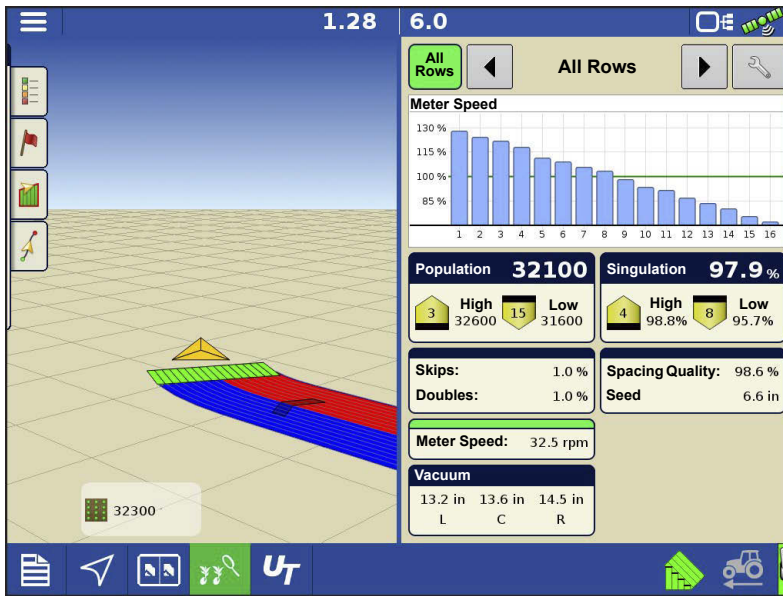



When planting through a turn or curve, the forward speed at each end of the planter can drastically change.

SureDrives have the capability to plant at the desired target population on all rows while making a turn. The SureDrive on each row will automatically adjust its RPM up or down to achieve the correct plant population at any given time. The Turn Compensation feature does not need

to be enabled; this feature will automatically work once planting occurs.

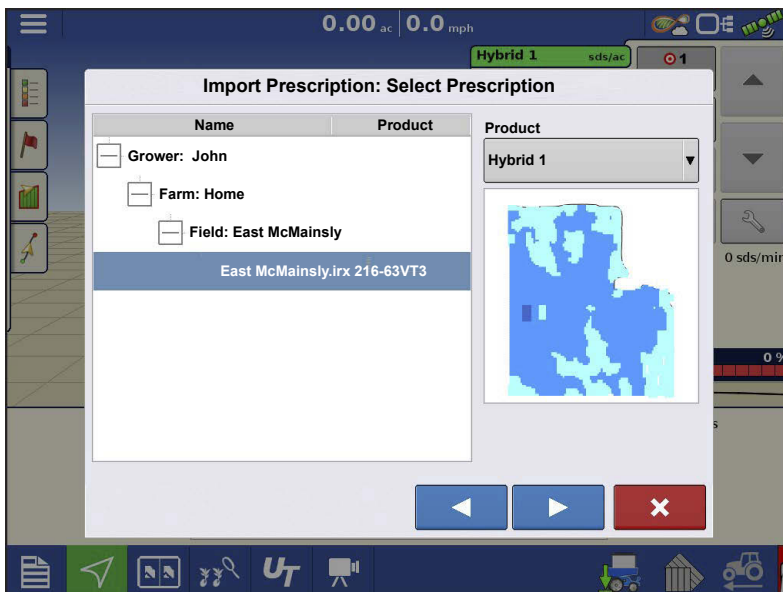
## Loading Prescriptions



1.  Press the Rate Setup button on the Product Control Toolbox.

2. Press the **Load Prescription** button. 

3. Using an inserted USB or AgFiniti Cloud, search for and highlight the correct .agsetup, .irx, or shape file and press .

4. Select the prescription in the Select

Prescription screen, and select the correct controlling product from the Product dropdown

box. A preview prescription map is displayed. Press .



5. In the Modify Prescription Screen the prescription scale, minimum to apply, and maximum to apply can be changed. As the three parameters are changed, the adjusted total to apply and average rate will update accordingly.

6. Press the .

7. After returning to the Mapping Screen, the prescription will appear on

the map while in a North Oriented view.

## Shape File Conversion

What is commonly called a shape file is actually a collection of three different files. All three of the files are required and must be present on the USB drive for the system to use shape file groups for variable rate product application. A single "shape file" can contain recommendation rates for multiple products.

1. To begin, press  on the Product Control Toolbox.



The Rate Control Settings screen appears

2. Press the **Load Prescription**

button. 

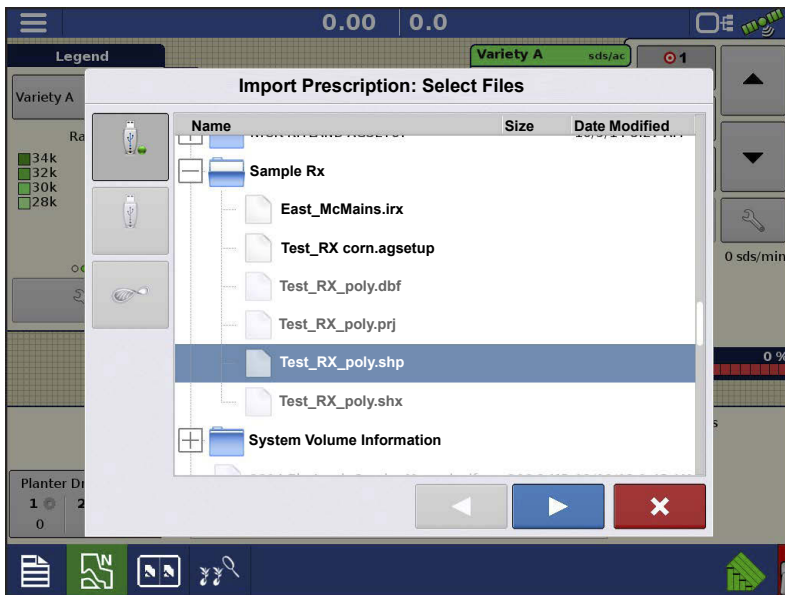

3. The **Select File** screen appears.

Highlight your desired .shp file and press .

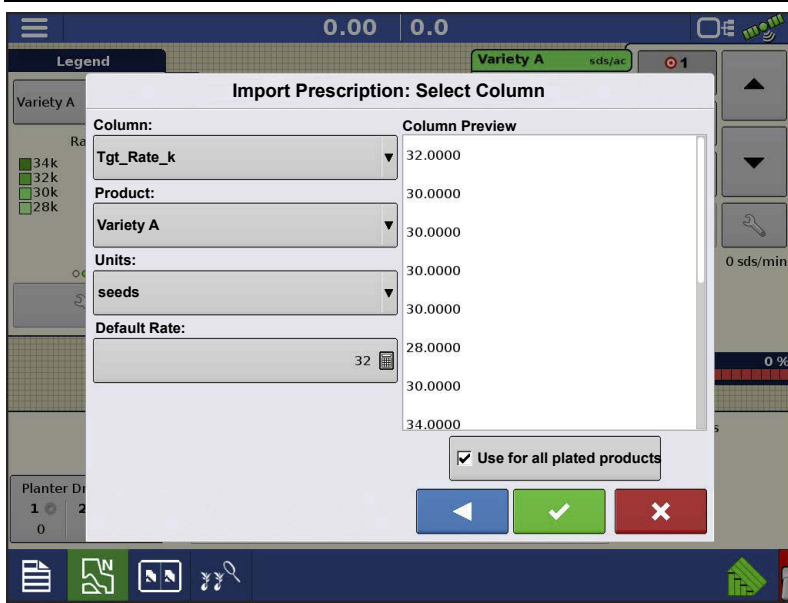

#### 4. Select **Column** From Shape File

Select the column that contains the product recommendation rate. The list on the right side of the dialog shows sample data from the selected column.

#### 5. Select **Units**

Select the controlling units for product application.

#### 6. **Default Rate** Setting

The system assigns a default rate. Use the on-screen keypad to edit the value if desired.



**NOTE!:** Select the product and units that the shape file prescription was made for. Selection of the wrong data column or unit will result in misapplication of product.



**ATTENTION!:** The only time the default rate is used by the system during product application is if the Rate Outside of Field selection is set to "**Rx default**". This setting is located in the equipment configuration settings portion of configuration setup. If the Rate Outside of Field selection is set to "Rx default", the default target rate will be used when the vehicle exits the area covered in the prescription map.

## Advanced Seed Monitoring

### Bar Graph

Swiping left or right will toggle the bar graph between all the following seed placement performance graphs.

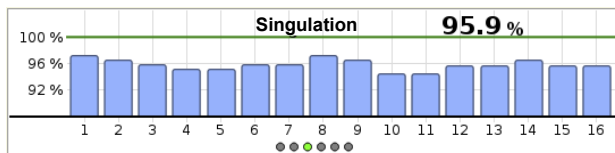
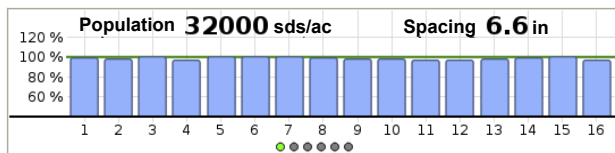



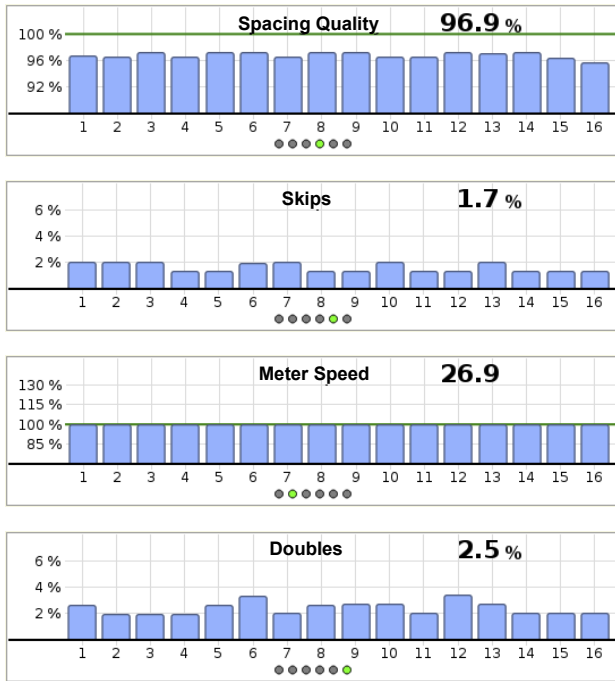

## Advanced Seed Monitoring



## Planter Performance screen

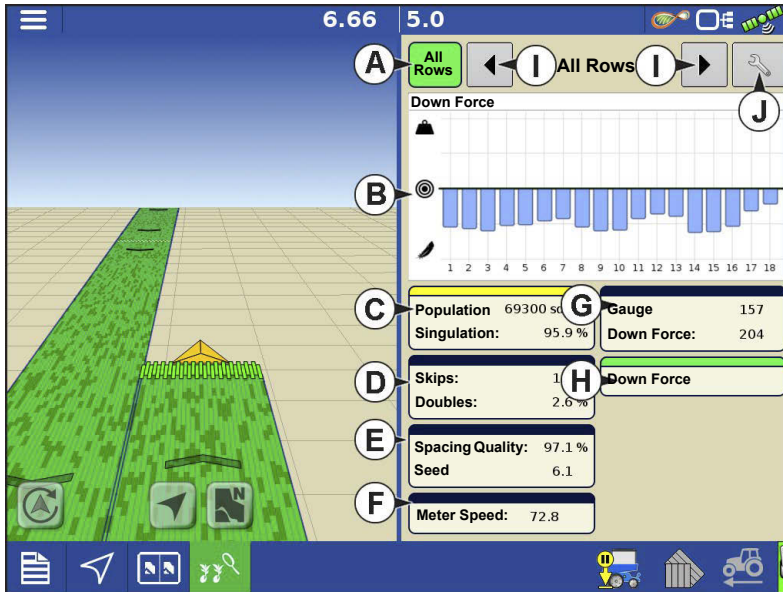

- A. All Rows
- B. Bar Graph
- C. Population/Singulation
- D. Skips/Doubles
- E. Spacing Quality/Seed Spacing
- F. Meter Speed
- G. Gauge Wheel/Down Force
- H. Down Force Trends
- I. Previous/Next Row Toggle

J. Seed Monitor Options

Advanced Seed Monitoring provides planter performance monitoring of seed meter singulation, skips/doubles and spacing quality, along with population and spacing information for all rows when planting compatible crops.

In addition, Advanced Seed Monitoring automatically determines and displays the rows operating at the highest and lowest levels for singulation and population. The screen also shows the averages for specific drive sections.

Bar graph can show individual row information for the averages shown on buttons (C, D, E, G, H).

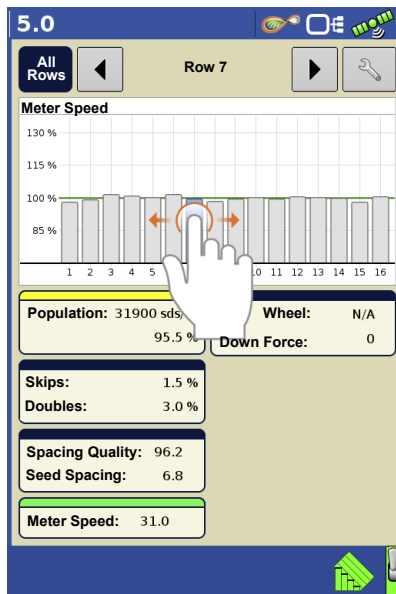

**A. All Rows**—Planter average for display items (C, D, E, G, H) at the bottom of the screen.

**B. Bar Graph**—Displays population, singulation, spacing quality, skips, and doubles, as selected by the operator.



**NOTE!** An operator may also touch the appropriate bar on the graph to show that specific rows Advanced Seed Monitoring values. To easily change between specific rows, tap and hold your finger on the bar graph, then drag left or right between rows.

Release your finger from the screen when the desired row is highlighted.

**C. Population**—Displays the average population for the planter, or sections of the planter, along with the highest and lowest population row.

**Singulation**—Displays the average Singulation for the planter, or selected sections of the planter, along with the highest and lowest rows.

- Singulation is a measure of the percent of seeds being properly metered so that one and only one seed drops from each seed cell of the seed meter.

**D. Skips/Doubles**—Displays the average skips and doubles for the planter

- Skips are a measure of the percentage of seed expected to be planted that are not due to a seed not being dropped by the seed meter.
- Doubles are a measure of the percentage of seed expected to be planted individually but instead two or more are dropped by the seed meter.

E. **Spacing Quality**—Displays the average spacing quality for the planter, or selected sections of the planter, along with the highest and lowest.

- Spacing quality is a measure of the percent of seeds being properly placed so that the spacing is as expected in the seed trench.

F. **Meter Speed**—Displays row by row meter speed

G. **Gauge Wheel/Down Force**

H. **Down Force Trends**

I. **Previous/Next Row Toggle**—Toggle through the rows using the arrow buttons or press on a specific row in the bar graph to show specific Advanced Seed Monitoring values for that row.



J. **Seed Monitor Options**—Pressing this button brings up Seed Monitor Options screen.



**NOTE!** If you are receiving Double, Skip, or Poor Spacing indicators while planting, refer to [Singulation Errors](#) on [page 452](#) and [Spacing Quality Errors](#) on [page 453](#).

## Creating Products

Creating planting products can be completed during initial setup or from the Product Selection screen of the Field Operation Wizard when starting a field operation.

Follow described steps to create planting varieties during initial setup.



1. Select **Product Type** (Crop) and **Product Units** (seeds or pounds).
2. Enter **Variety** or **Hybrid** name.

Press  to enter a unique name for the variety or hybrid.

3. Enter **Variety** or **Hybrid Manufacturer** is applicable.

Manufacturer name can be added to the drop-down menu by pressing .

4. Press  to complete Product setup.

Created variety or hybrid should appear under the Planting heading located on the Product tab of the Configuration Setup Screen.

## Create Configuration

A wizard will guide you through the process of selecting or creating a configuration with application settings.

The configuration can be started in two places:



OR

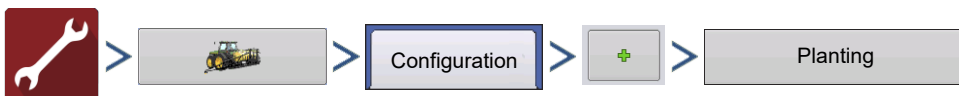

Your Operating Configuration will then be viewable when you start a new Field Operation.

You can also use the **Manage Equipment** button to create or edit specific vehicles and implements.

## Planter Options



### Seed Monitor



OR

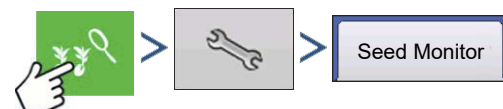

In the **Seed Monitor** tab you can adjust Seed Monitor alarm

---

thresholds, Gain, and Advanced Seed Monitoring alarm thresholds. The screen also has access to module Diagnostics.

**Gain** shows the population multiplier used to adjust the population if the seed tube is not sensing the actual seed population.

- Always start with the Gain set to 1.
- Gain Setting is saved by crop type.
- For Corn, Gain values should **always** be set to 1.

**Gain adjust example:** Planting soybeans at a target population of 150,000, the on-screen population readout is 140,000. First perform a dig check to verify the correct population is being planted; then check the seed tube sensors to make sure they are clean of dust and debris. Once the checks have been done, the Gain can be adjusted so the on-screen population readout reflects the true population. Divide the target population by the population readout ( $150,000 / 140,000 = 1.07$ ). Enter 1.07 as the new Gain value.

### Advanced Seed Monitoring Thresholds

- Singulation Alarm
- Spacing Alarm

Crops that are supported by Advanced Seed Monitoring

- Corn
- Sorghum
- Cotton
- Sugar Beets
- Cucumber
- Vegetable (generic vegetable crop type)
- Popcorn



**WARNING!** Do not change the Default Gain setting of 1 for any crops that are monitored by Advanced Seed Monitoring.

# Population Alarms

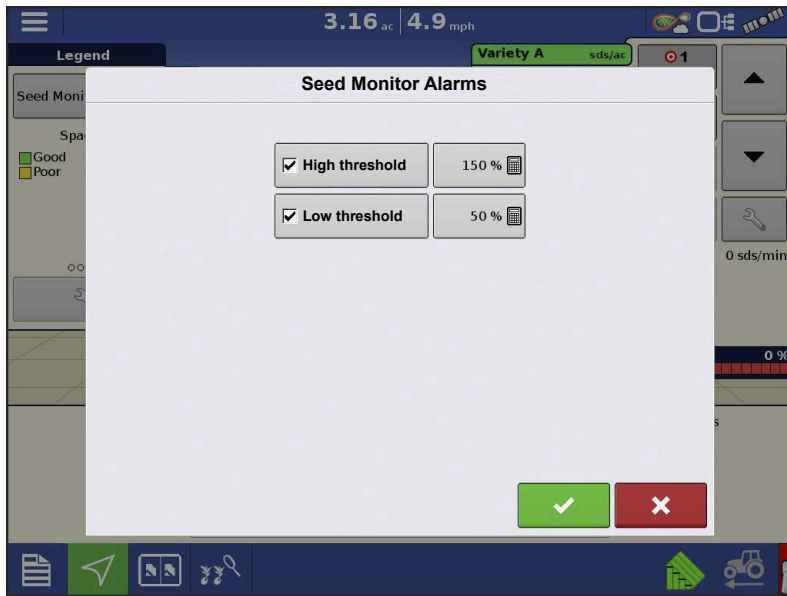

Adjust Ag Leader Seed Tube

Monitoring Module alarm thresholds.

This screen can be accessed in one of two ways:

- Pressing the **Population Alarms** button at the Planter Option screen.



OR

- Pressing the **Population Alarms** button at the Seed Monitor Setup screen.



**High threshold** and **Low threshold** check boxes allow a percentage of error to be assigned that will trigger the rate alarm. Unchecking the High and Low threshold will disable that specific alarm. Population will still be displayed in the planter performance graphs.

## Sensor Configuration



From this screen you can disable a specific row's seed tube sensor. This will disable all alarms, and that row in the planter performance graphs.

## Vacuum & Pressure Configuration



If Air Seed Delivery or row Vacuum sensors are installed, you must configure them from this screen. Highlight the appropriate Row, then press **Install**. (This will also calibrate the vacuum sensor. Be sure to have the vacuum systems turned OFF.)

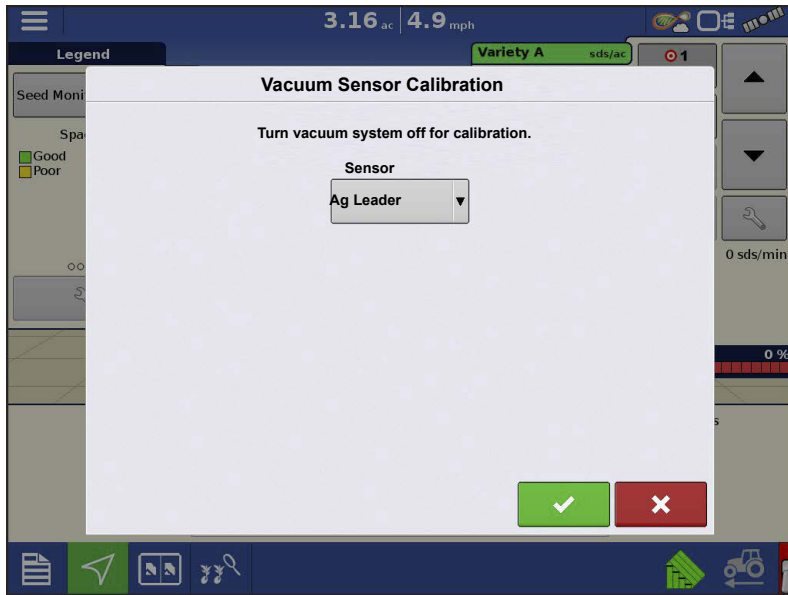

In the next screen select the Sensor Type. Select **Ag Leader** for all sensors provided by Ag Leader. Select **Generic** for all other type of sensors.

**NOTE!** If a **Generic** sensor type is selected, the sensors Slope value must be known. The Slope value is in units of mV/inH<sub>2</sub>O (mV/mbar).

## Planter Drives

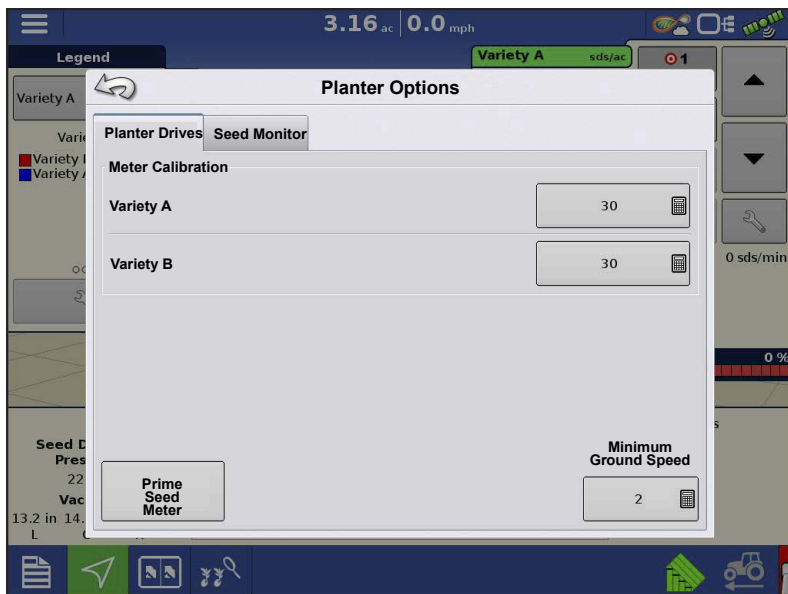



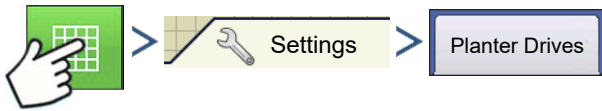

OR

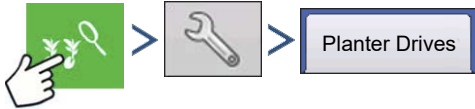

In the Planter Drives tab the sds/rev can be set, the seed meters can be Primed, and the Minimum Ground Speed can be set.

**Minimum Ground Speed**—The planter will plant at this simulated ground speed, until displayed ground speed is above this value. This fixed ground speed compensates for delays in acquiring an initial ground speed when starting from a stand still. Planting at the minimum ground speed will occur when the jump start button is pressed. Once the Jump Start button is pressed, it will remain active for 10 seconds, or until pressed again.



A. Jump Start **Not Active**



B. Jump Start **Active**

### Priming Seed Rate Meters

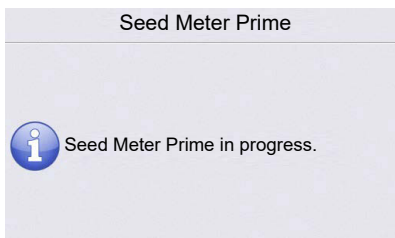

The Seed Meter Prime is used to charge the seed meter when filling with seed.



OR

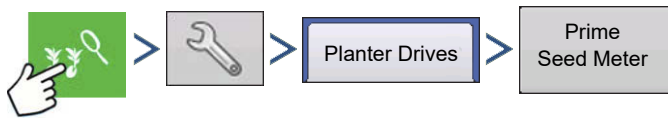

A message displays, stating “Seed Meter Prime in Progress.” While this message displays, the seed meter will turn one (and only one) revolution automatically. When complete, return to the Planter Options screen.

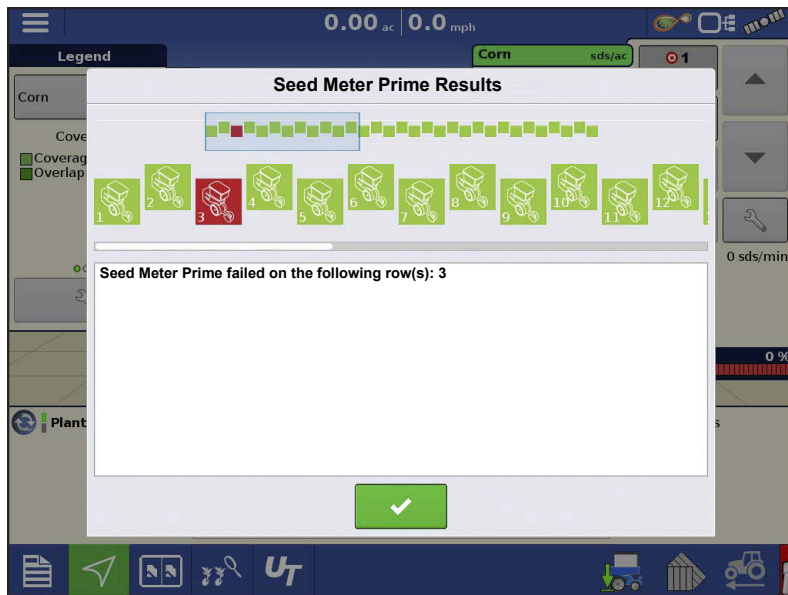

If a row fails to prime the operator will be presented with a “Seed Meter Prime Results” screen indicating which row(s) has failed. A failed meter prime will occur if the SureDrive does not turn the 1 full revolution. Inspect the SureDrive and seed meter if this occurs, and prime the meters again if necessary.

## Legend Setup

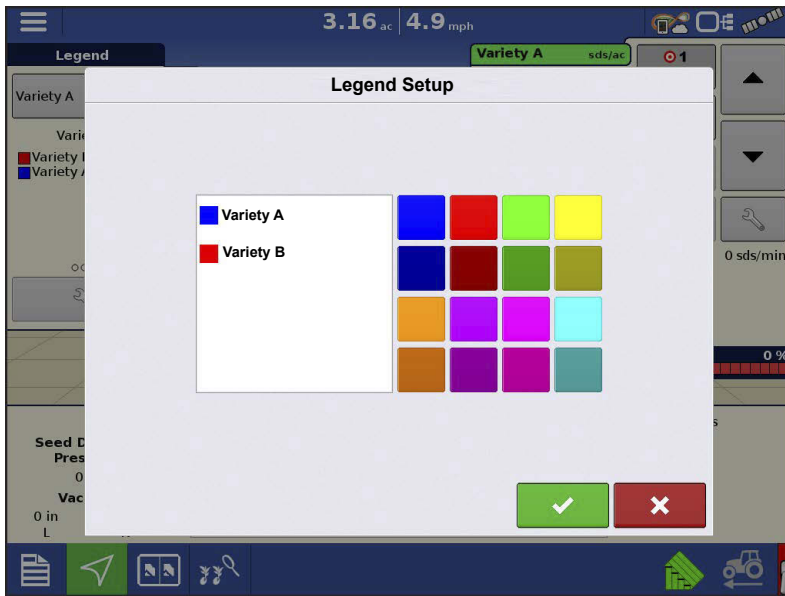

when finished.

Pressing the area under the seed varieties on the Map Legend Tab of the Mapping Toolbox opens the **Legend Setup** screen.

If a variety was selected, a list appears on the left-hand side of the Legend Setup screen. To change the color of one of these varieties, highlight that variety and then press a color on the color palette at right. Press 

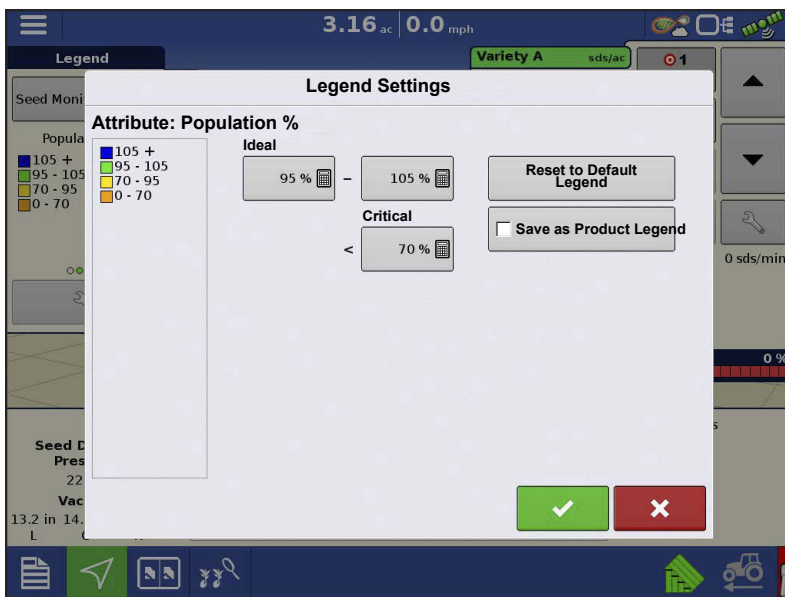

If Seed Monitor was selected, the **Legend Settings** screen appears (similar to the screen to the right). Use this screen to adjust the legends thresholds. Legend settings screen may differ depending on the legend that is displayed. There are legend settings for Population, Population %, Singulation, and Spacing. Press  when finished.

# Seed Rows

This feature enables creating and using configurations to plant male and female varieties.

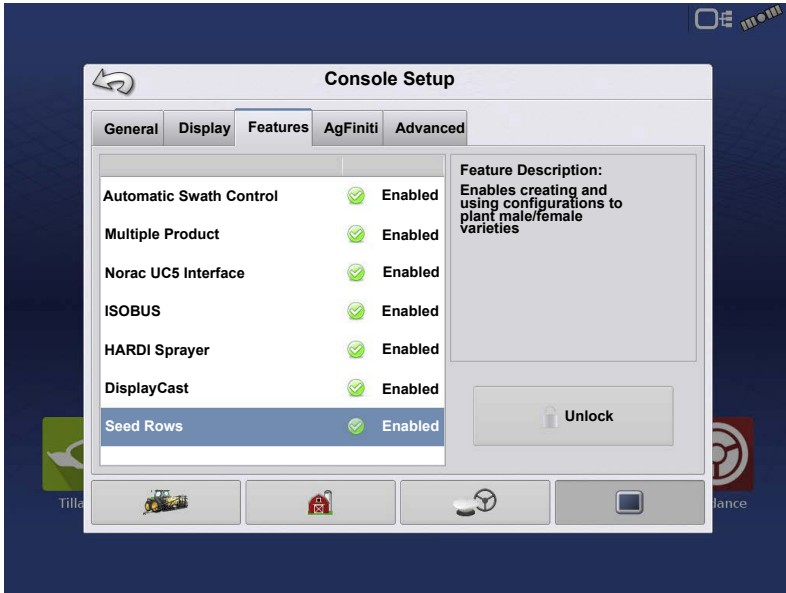

To utilize this feature a **Seed Rows** unlock and **Multiple Product** unlock must be purchased and entered in the display. The Feature Tab is where you can enter unlock codes. Unlock codes are unique to the serial number of each display and the feature registration number. You must supply these numbers to your dealer when purchasing any unlock codes. Press



to enter the unlock code and

press  to enable the feature.

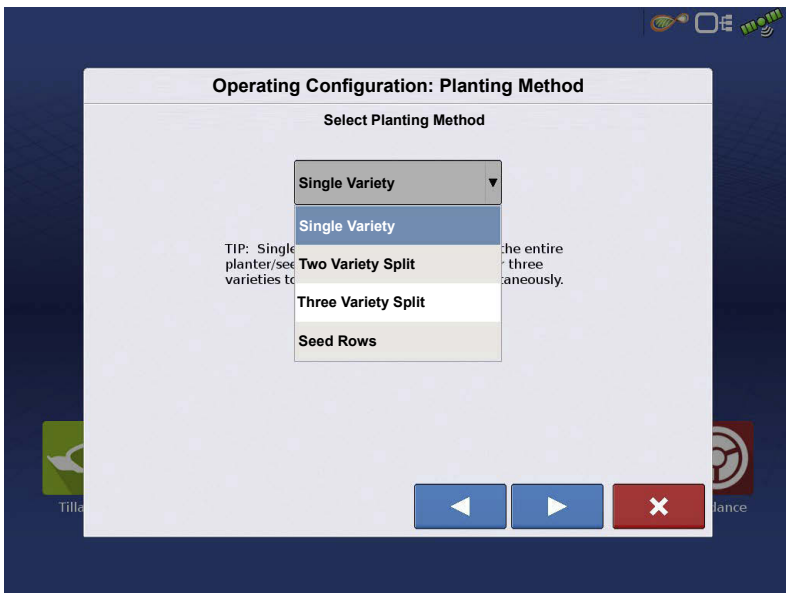

A new configuration must be created to begin using this feature.

1. In the configuration wizard on the **Operating Configuration: Planting Method** screen, **Seed Rows** must be selected from the drop down list.

Press .

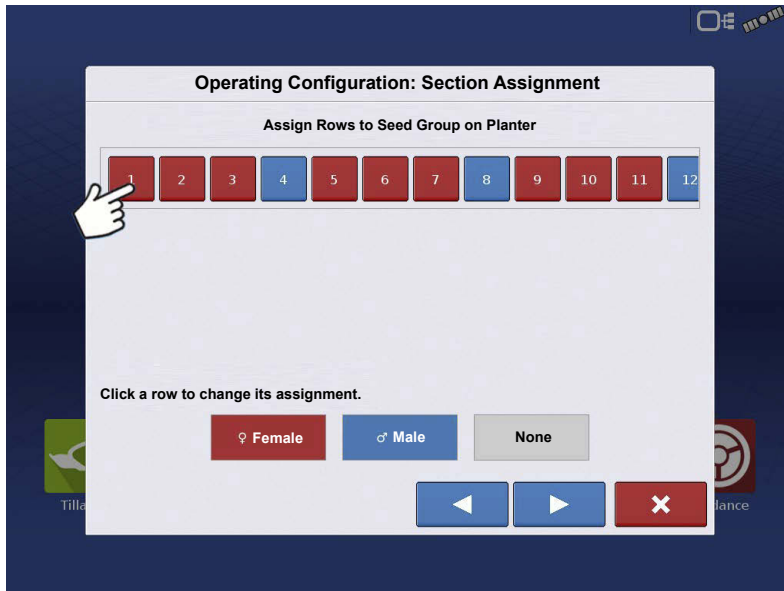

2. In the **Section Assignment** screen assign row to the appropriate seed group; **Male**, **Female**, or **None**. Each row can be toggled between all three group options. Press . Complete the configuration.

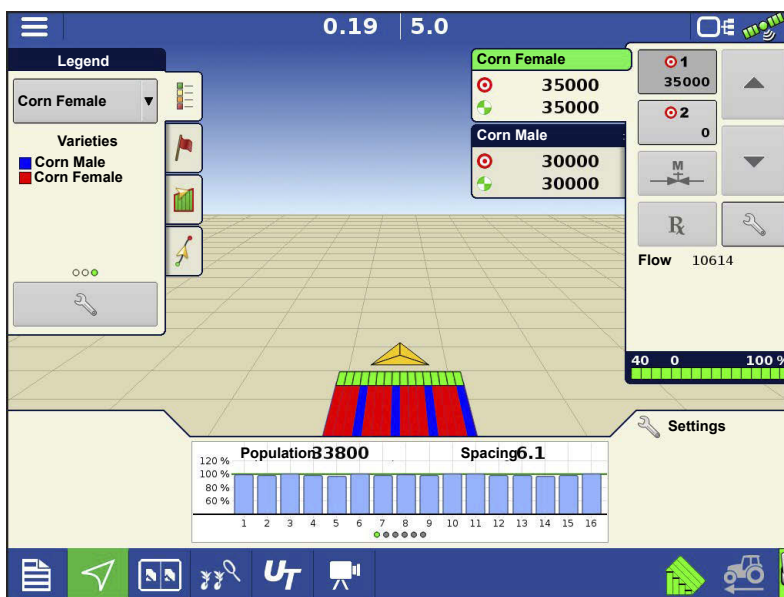

With the operating configuration loaded to the Map View Screen, the Male and Female assigned rows will map as two separate varieties; with the ability to also enter individual planting rates for each variety.

 **ATTENTION!** When two different target rates are entered, the actual population displayed in the map screen bar graph and Advanced Seed

Monitoring screen will represent a weighted average over the planter rows. Seed Spacing and Meter Speed will also be represented as an average.

---

Singulation, Skips, Doubles, and Spacing Quality will be represented accurately since they are displayed as a percentage.



**Note!:** Section assignment will default the female rows to Switch 1 and the male rows to Switch 2. The section assignment can be viewed or edited in the Auxiliary Input screen.

## Automatic AutoSwath Control

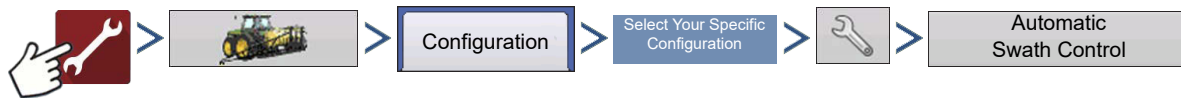

OR

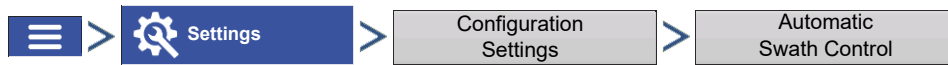

**NOTE!:** To use AutoSwath for planting operations, you are required to use a 5 Hz or higher GPS output rate. AutoSwath control will not allow sections to be turned on until the master and planting section switches are on. If you have less than a 5 Hz GPS output rate and you select AutoSwath, a warning appears, telling you that AutoSwath Control is not available at less than 5 Hz.

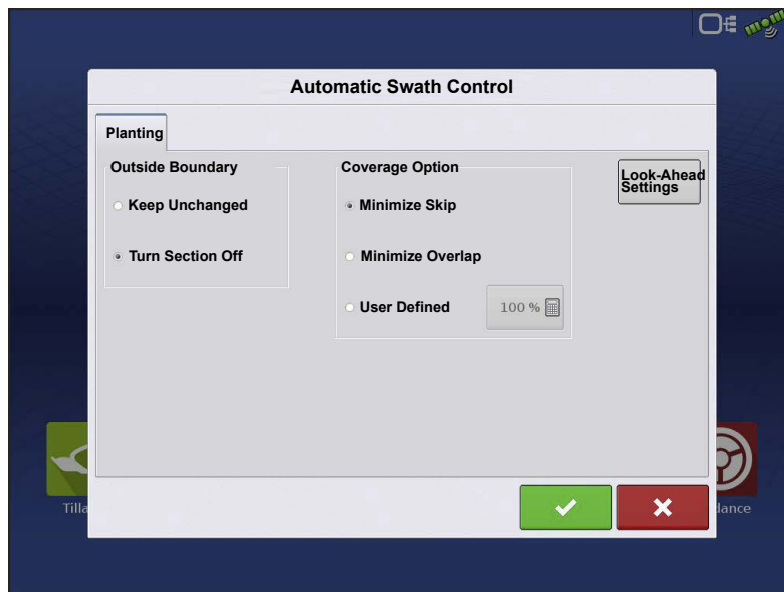

The Automatic Swath Control feature turns sections off and on automatically based upon the following conditions:

- Entering and exiting internal and outer field boundaries.
- Entering and exiting previously-applied areas within a field.

**Outside Boundary Option**—Select one of the two options to determine system behavior when a section exits

a field boundary.

- **Keep Unchanged**—Swath section on/off status will not change when exiting the field as defined by the outside boundary.
- **Turn Section Off**—Swath section will cease planting when exiting the field as defined by the outside boundary.
- **Coverage Option**

---

In the Coverage Option area, you must choose between three options:

- The **Minimize Skip** option turns off the swath section after the entire section is fully inside your coverage area. This prevents the possibility of skips.
- The **Minimize Overlap** option turns off the swath section when that section first enters your coverage area. This prevents the possibility of overlaps.
- The **User Defined** option allows you to choose what percentage of the swath section is within the coverage area before that section turns off. For example, if you choose 50%, then the section will switch off when half of it is within your coverage area.

## Look-Ahead Settings

AutoSwath Control settings are saved per controller per configuration. There can be different Look-Ahead settings saved for equipment of the same operation. The Look-Ahead Settings screen will contain every controller's Look-Aheads.

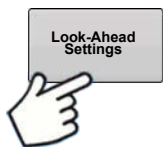

On the AutoSwath Control screen, press the Look-Ahead button.

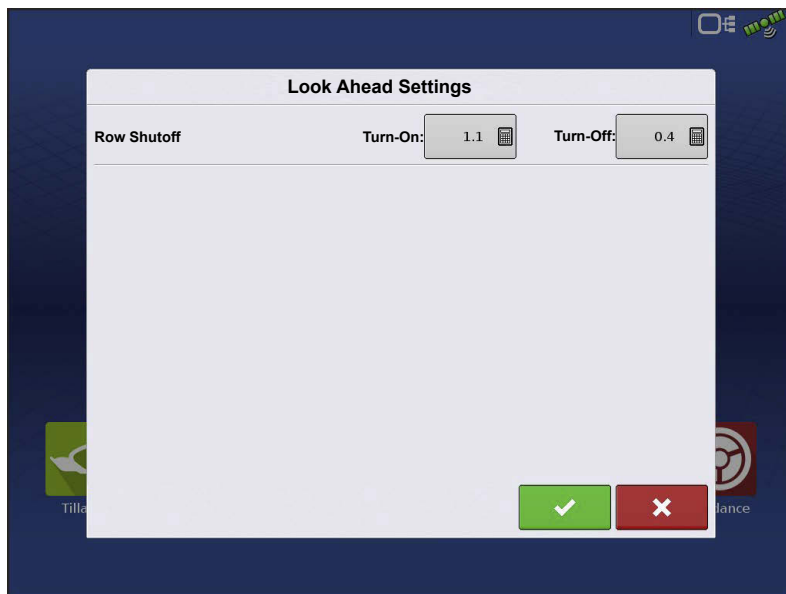

**Turn-On**—This setting determines how far ahead the system looks to turn the sections back on. This setting compensates for delay in the planting control system when the implement sections are turned on.



**ATTENTION!** For best performance, do not change travel speed as you are entering the unplanted area. Accelerate either well

before entering the unplanted area, or after all clutch sections have turned On.

**Turn-Off**—This setting determines how far ahead the system looks to turn the sections off. This setting compensates for delay in the product control system when the sections are turned off.





**ATTENTION!:** For best performance, do not change travel speed as you are nearing the planted area. Decelerate either well before entering planted area, or after all clutch sections have turned Off.



**NOTE!:** Using the default settings should produce good field results. However, always take the time to check for proper seed placement in the field and make system setting adjustments as needed. Do not rely solely upon the appearance of the On-Screen map. The on screen map will not show gaps and overlaps caused by incorrect GPS Offsets or AutoSwath Look-Ahead settings.

## Configuring Offset Planter Sections



OR

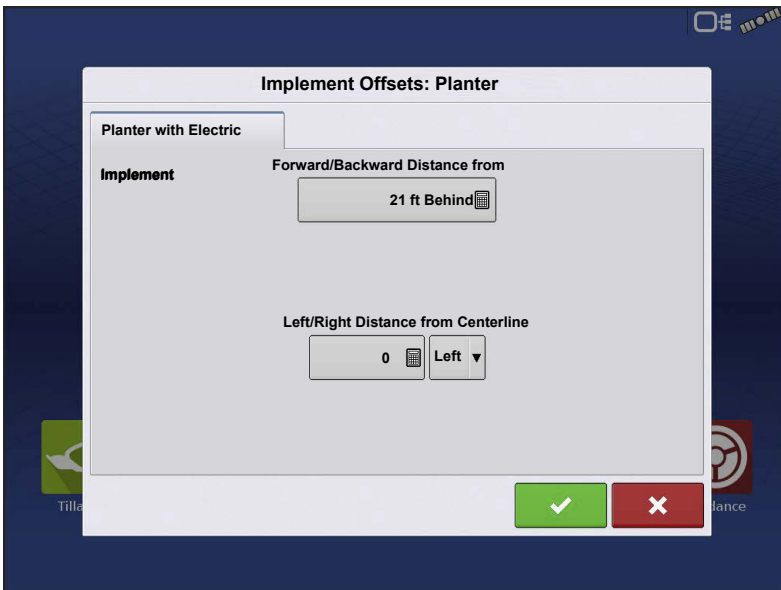
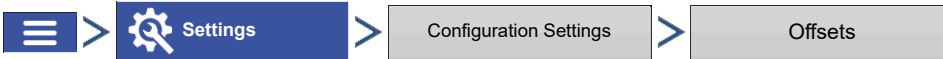

Implement Offsets screen appears.

Defaults to the value entered during Configuration Wizard.

Planter sections can independently be offset forward or back.

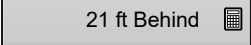
1. Press  to access Swath Section Offsets screen.

	Width	F/B Offset	L/R Offset
8	2.500	21.000	11.250
9	2.500	21.000	8.750
10	2.500	21.000	6.250
11	2.500	26.000	3.750
12	2.500	26.000	1.250
13	2.500	26.000	1.250
14	2.500	26.000	3.750
15	2.500	21.000	6.250
16	2.500	21.000	8.750

2. Select Swath section to edit and press Edit button.

3. Enter Forward/Backward Offset for that specific section from hitch point.

4. Press  to enter change.

Setup will indicate which offset is entered

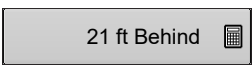
 **Global**—All

sections have the same offset.

 **Individual**—At least one section has a different offset.

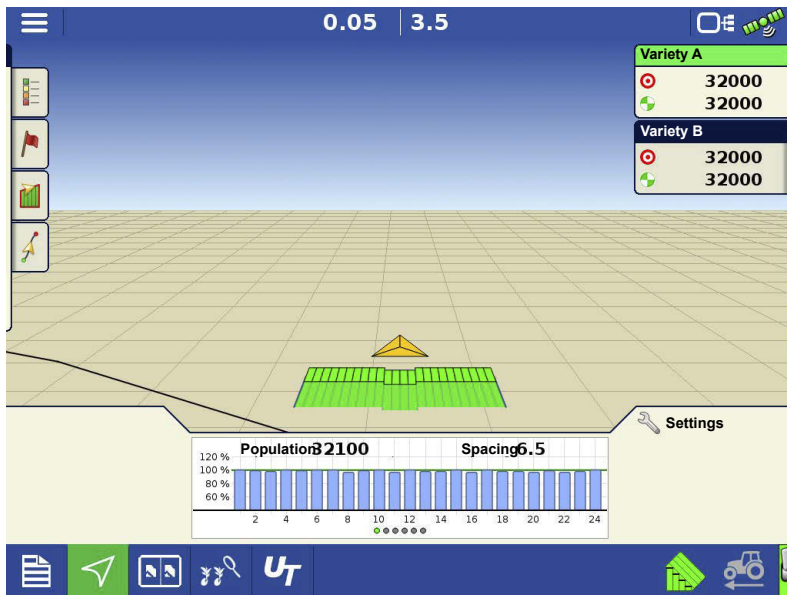

Runscreen reflects section offsets

 **NOTE!** If a planter has narrow rows (less than 30 inch row spacing) Ag Leader recommends grouping the outer planter sections together as a single swath section. Due to GPS drift, sections less than 30 inches may be turned on and off by AutoSwath when planting next to a covered area.

---

## Checking AutoSwath Performance for Row Shutoff

Always take the time to check for proper seed placement in the field and make system setting adjustments as needed. Do not rely solely upon the appearance of the On-Screen map. The on screen map will not show gaps and overlaps caused by incorrect GPS Offsets or AutoSwath Look-Ahead settings. Verify settings with the following procedure:

1. Stop the planter within 20 feet of the planted headland.
2. Select one row unit from each planter swath section to observe.
3. Remove the down pressure from the closing wheel of each selected row unit.
4. Hold the closing wheels off the ground by attaching a chain or strap from the hopper support panel to the closing wheel arm. (This prevents the closing wheels from closing the seed trench).



**NOTE!:** Securing these closing wheels up allows you to observe the planted seed in the trench so that you can observe when the AutoSwath is turned off and on during the seed application.

5. Resume planting in your normal fashion, then stop when you are 20 feet out of the headland of the next pass.
6. Stop the planter and observe the AutoSwath shutting off and turning on to see if the results are acceptable.
  - If the results are correct, then return the closing wheels to their previous operational state. Close the seed trench on the observed rows and return to planting.
  - If you suspect the results are incorrect, then adjust the appropriate Look-Ahead setting one-tenth (.1) second per trial. Larger adjustments can cause unintentional large changes in the AutoSwath's performance. When adjusting the Look-Ahead numbers from the suggested settings, it is recommended that you observe multiple trials to confirm the operations' accuracy.
  - If you encounter overplanting or underplanting problems, see "Fixing Overplanting and Underplanting in AutoSwath" below.

---

## Fixing Overplanting and Underplanting in AutoSwath

### AutoSwath Function—Turn Off Look Ahead

**Problem**—Underplanting

**Recommended Action**—Decrease Look-Ahead number

**Result**—The AutoSwath anticipates headlands later and turns the planter off later.

**Problem**— Overplanting

**Recommended Action**—Increase Look-Ahead number

**Result**—The AutoSwath anticipates headlands sooner and turns the planter off sooner.

### AutoSwath Function—Turn On Look Ahead

**Problem**—Underplanting

**Recommended Action**—Increase Look-Ahead number

**Result**—The AutoSwath anticipates headlands sooner and turns the planter on sooner.

**Problem**—Overplanting

**Recommended Action**—Decrease Look-Ahead number

**Result**—The AutoSwath anticipates headlands later and turns the planter on later.

## SureDrive Alarms

**Stalled** – Motor on a specific row has stopped turning. After following the below Recommendation steps and resolving the issue, in order to clear the Stalled alarm cycle the planter to a non-planting state, to a planting state (turning the Master Switch OFF then ON, or raising and lowering the planter to trip the implement switch will accomplish this).

### Recommendation(s)

- Inspect planter meter. Verify nothing is restricting its rotation. Verify it does not take more force to turn versus other meters on the planter.
- Inspect the SureDrive. Verify nothing is restricting its operation.
- Inspect SureDrive mounting and bracket.

- 
- Inspect SureDrive and meter linkage. Verify coupler is correctly installed and engaged with the SureDrive.

**Maximum Meter Speed** – SureDrives are operating at maximum RPM.

**Recommendation(s)**

- Verify the Sds/rev value is correct in the Planter Options screen.
- Verify the Target Rate is correct.
- Verify the display speed is accurate.
- Inspect the operating configurations number of rows and row width.
- Planting speed may be too fast for the planting application. Reduce vehicle speed.

**Motor Communication Error** – CAN communication has been lost with a SureDrive on a specific row.

**Recommendation(s)**

- Inspect cabling going from the RCM to the SureDrive. Also inspect planter CAN cabling leading to the RCM.
- Note CAN light status on SureDrive for further diagnosis.

**Low Voltage** – Voltage for a SureDrive has dropped below 9 volts on a specific row.

**Recommendation**

- Inspect cabling going from the RCM to the SureDrive.
- Verify high power going to the RCM. Check for 12V on the 2-pin duetsch connection.
- Inspect power distribution cabling leading back to the generator/power source.

## Diagnostic Screens

To access the Row or Planter Control Module(s) Diagnostics screen, press:



Technical Support may request that you look at these screens for help in diagnosing a problem.



**Row Control Module** — In the CAN-B Devices screen highlight any of the items marked Planter Row Control Module, then press the Diagnostics button. This will display diagnostic values for all rows on the planter. The Row Module Diagnostics screen includes:

- **RPMs** — Rotational speed of SureDrive on a specific row.
- **Seeds/sec** — Provides

instantaneous feedback from the matching seed tube sensor. This feedback is not dependent on operating state. This is a useful tool for troubleshooting seed tube sensors or performing pre-season checks to verify sensor operation.

- **Motor Load** — Represents the current Duty Cycle (%) a specific SureDrive is operating at. This is a useful tool for troubleshooting if a specific planter meter is turning harder vs. other meters.
- **Voltage** — Current voltage at an SureDrive on a specific row.
- **Stalled** — Indicates whether an SureDrive has stalled.



Caution symbol will appear in this column if a drive as stalled. To return a drive to operational state, first inspect and correct the issue that initially stalled the drive. Then cycle the planter to a non-planting state, to a planting state (turning the Master Switch OFF then ON, or raising and lowering the planter to trip the implement switch will accomplish this).

## Planter Control Module

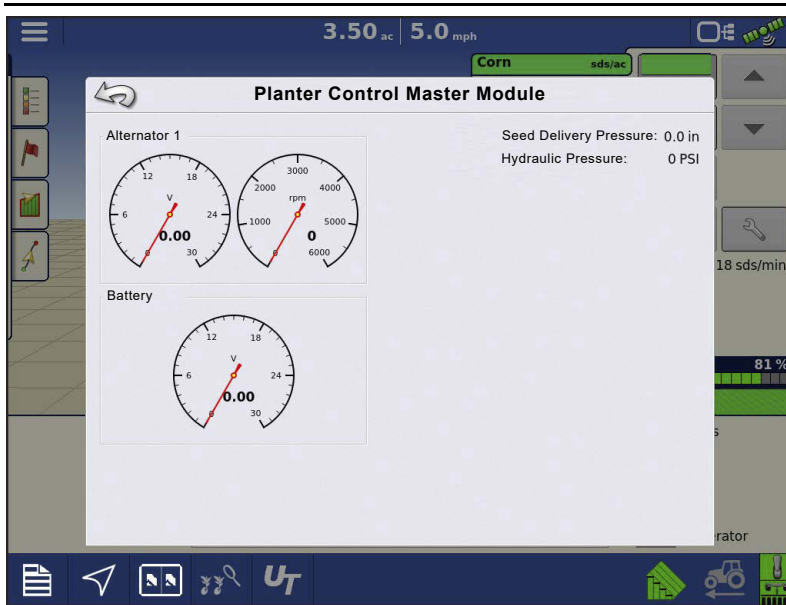

In the CAN-B Devices screen highlight the item marked Planter Control Master Module, then press the Diagnostics button. This will display diagnostic values being input to the Planter Control Master Module. The Planter Control Master Module Diagnostics screen includes:

- **Battery Voltage** — Voltage of battery connected to the alternator.
- **Alternator Voltage** — Voltage being

generated by the alternator.

- **Alternator Speed** — Indicates the RPM of the alternator.
- **Seed Delivery Pressure** — Pressure from bulk fill pressure sensor connected to the Planer Control Module. (This value will be 0 if a bulk fill sensor is not configured)
- **Hydraulic Pressure** — Input pressure from tractor to the hydraulic valve block(s) for Down Force. (This value will be 0 if Hydraulic Down Force is not configured)

## FAQ

-What are the hydraulic requirements for the generator and hydraulic down force?

The generator requires approximately 6 GPM and at 6 GPM will provide  $\approx$ 4000 RPM. It is NOT recommended to tie the generator hydraulic supply/return hoses into any bulk fill or vacuum fan hydraulic source. The generator tank hose can tie into fan case drain lines. The Hydraulic Down Force requires around 3 GPM. It is NOT recommended to use power beyond as the hydraulic supply for either the generator or Individual Row Hydraulic Down Force.

-How many amps are the generator capable of producing?

The generator can produce  $\approx$ 200 amps. This is dependent on alternator RPM and temperature.

- 3000 RPM  $\approx$  185 amps @ 25 C (77 F)
- 3000 RPM  $\approx$  155 amps @ 80 C (176 F)

- c. 4000 RPM  $\approx$  200 amps @ 25 C (77 F)
- d. 4000 RPM  $\approx$  165 amps @ 80 C (176 F)

The generator is capable of turning faster the 4000 RPM, this will however not create more amperage.

-Does the display log SureDrive motor RPM?

No. Actual rate is logged, which is calculated using motor RPM.

-How many vacuum pressure sensors are supported?

Up to 3 vacuum sensors are supported.

-Does the Row Control Module (RCM) have enough power to run a Wave Vision seed tube sensor?

Yes.

-Can the generator circuit breaker be left in the ON position when not in use?

Yes. The circuit breaker can be left in the ON position when the generator is not in use.

Leaving circuit breaker ON will not cause any voltage leak from the battery to the SureDrive system due to a coil disconnect in the alternator. When the generator is not in use for long periods of time, the circuit breaker can be turned OFF as a precautionary measure.

-What is a CAN Repeater Module; and when is it required?

A CAN Repeater Module is a component that is used on Ag Leaders Individual Row Hydraulic Down Force and SureDrive systems. It is only installed on systems with a Local CANBUS that exceeds a certain length. The modules purpose is to “repeat” CAN messages on these longer BUS lines to ensure communication between all of the modules connected. Ag Leader will supply the CAN Repeater Module in appropriate kits as needed.

## SureDrive Indicator Lights



**Left LED (A)**

Status	Definition
OFF	No Motor Rotation
Solid Green	Rotating Clockwise
Solid Yellow	Rotating Counter Clockwise



**Right LED (B)**

Status	Definition
OFF	No CAN POWER
Solid Green	CAN BUS Communication
Fast Blinking Green	Motor Driver Upgrading
Slow Blinking Green	CAN BUS OK
Solid/Blinking Amber	CAN BUS Error
Solid Red	CAN BUS Off
Blinking Red	High Power Voltage is Low



**NOTE!:** Motor Driver Upgrading (fast-blink green) will take priority over ALL other LED states. High Power Voltage Low (blinking red) will take priority over other LED states; with exception to the Motor Driver Upgrading state.

See image to the right for Left (A) and Right (B) Indicator lights. Be sure to take notice of the SureDrive orientation before diagnosing the LED status.

**Module Diagnostic Lights**



**Planter Control Module (PCM)**

Φ **High Power** – Indicates ECU power (12V) to the module.

Status	Definition
OFF	No Power
Blinking Yellow	Firmware Upgrading
Solid Green	High Power OK

1. Local CAN – Indicates if the PCM is communicating with the RCM's.

2. Display CAN – Indicates if the PCM is communicating with the controlling display.

---

Status	Definition
OFF	No CAN Communication
Solid Red	CAN BUS Off
Solid/Blinking Yellow	CAN BUS Error
Blinking Green	CAN BUS Communicating

### Row Control Module (RCM)

Φ High Power – Indicates high power (12V) to the module.

Status	Definition
OFF	No Power
Blinking Red	RCM Indexing
Solid Red	Low Voltage
Solid Green	High Power OK

1. Local CAN – Indicates if the RCM is communicating with the PCM.
2. Display CAN – Indicates if the RCM is communicating with the Motor Driver.



**NOTE!:** LED #2 will be OFF if SureDrives are not configured.

Status	Definition
OFF	No CAN Communication
Solid Red	CAN BUS Off
Solid/Blinking Yellow	CAN BUS Error
Blinking Green	CAN BUS Communicating

### RCM Errors

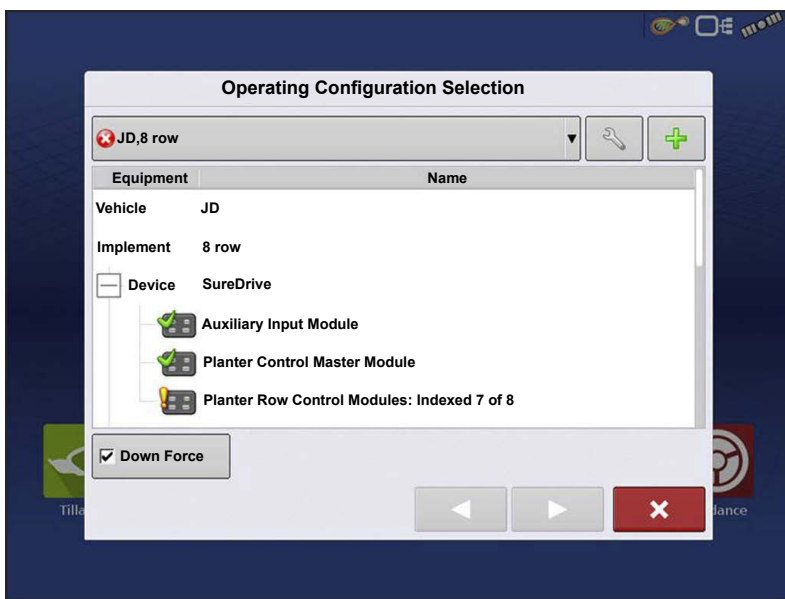

All modules have been detected on the CAN bus but there is an indexing issue.



There are more modules on the CAN bus than what the config requires.

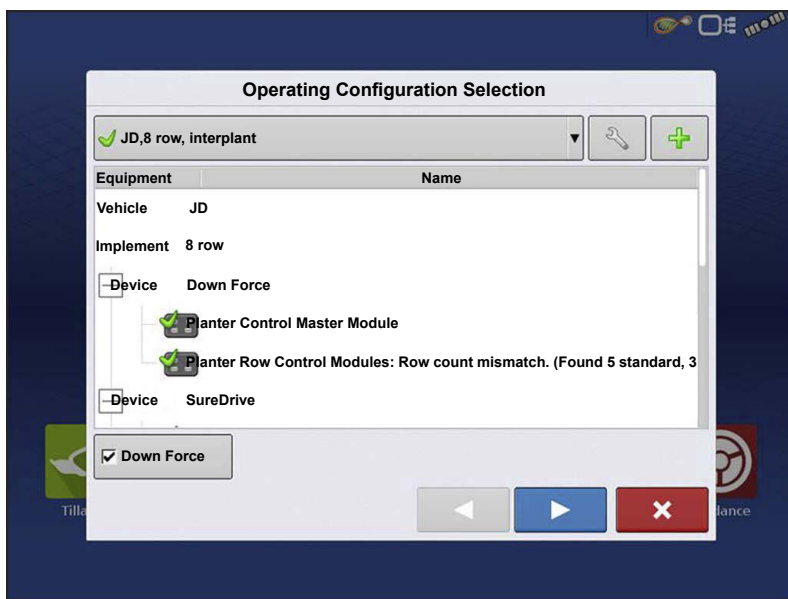

There is an actual Split Row Mismatch due to a bad jumper in one of the interplant row modules.



How the Field Select Wizard should appear when all RCM modules have been found on the CAN Bus, properly indexed, and properly assigned to each of the rows.

## Implement Switch Module



**Left LED**

Status	Definition
OFF	No CAN Communication
Solid Red	CAN BUS Off
Solid/Blinking Yellow	CAN BUS Error
Blinking Green	CAN BUS Communicating

**Right LED**

Status	Definition
OFF	Planter Up
Solid Blue	Planter Down

**Implement Switch Status Indicator**



Highlight a Row Control Module in the CAN A tab and press the Diagnostics button in the lower right-hand corner to view the implement switch status.



---

## Troubleshooting Seed Monitor

**Problem**—Not receiving population readings from all or certain planter rows.

**Solution:**

1. Refer to the Row Control Module (RCM) Diagnostics page. Verify there is no feedback on the failed rows in the seeds per second column when seed passes by the seed sensor.
2. Check for 12V on the 2 pin duetsch connection that provides high power to the RCM.
3. Check for 8V between the power (Pin C) and ground pins (Pin B) on the connection that plugs into the seed tube sensor.
4. Check for 8V between the sense (Pin A) and ground pins (Pin B) on the connection that plugs into the seed tube sensor.
5. If voltages are all proper, move the seed tube sensor to a functioning row to verify it is the problematic component.



**NOTE!:** If incorrect voltage is received at any location noted above, trace down the power issue by rechecking for voltage at harness and module connection points. Refer to the Ag Leader Knowledgebase for cable schematics. Call/email Technical Support for further assistance.

# Singulation Errors

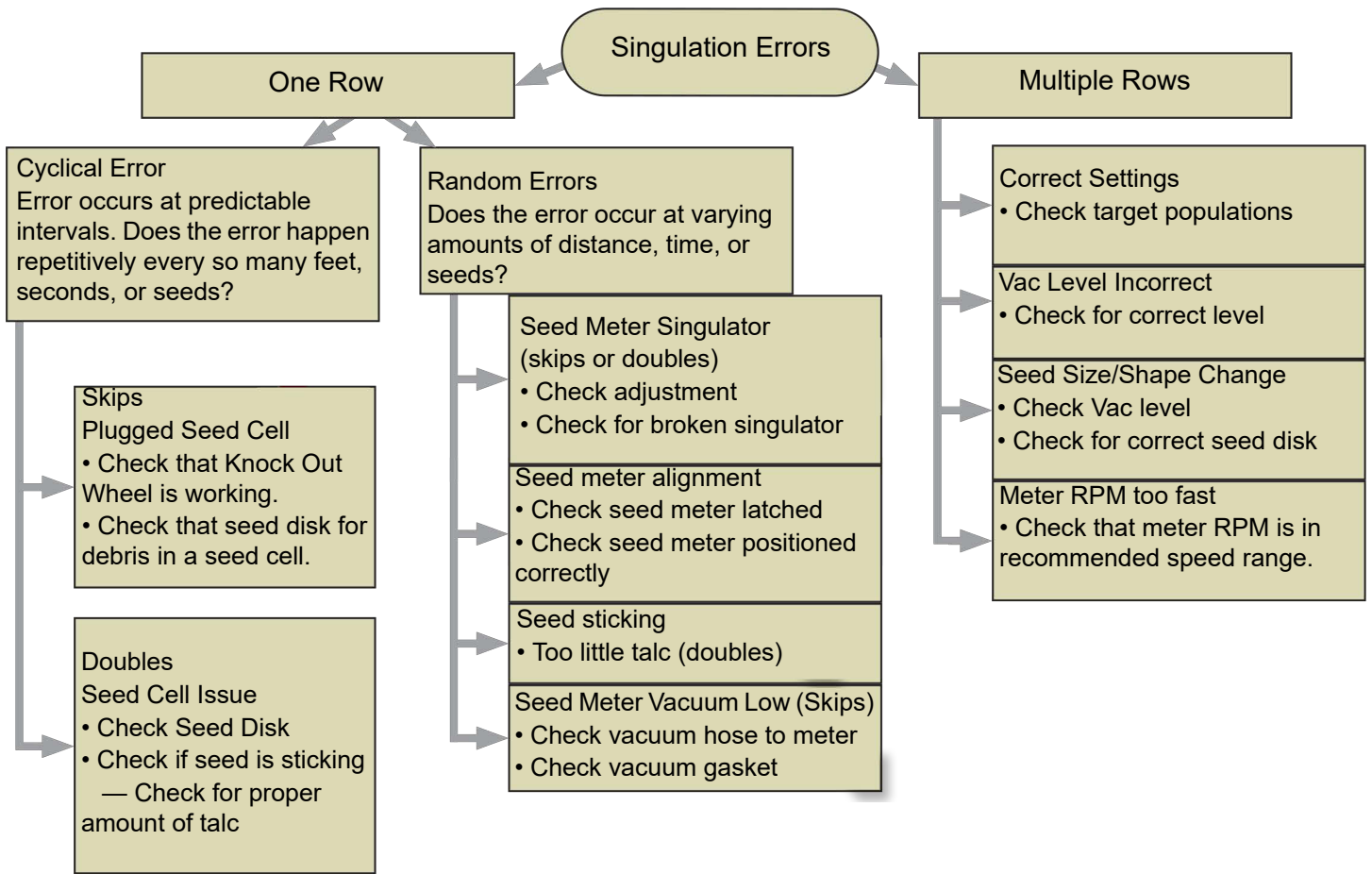



## Spacing Quality Errors

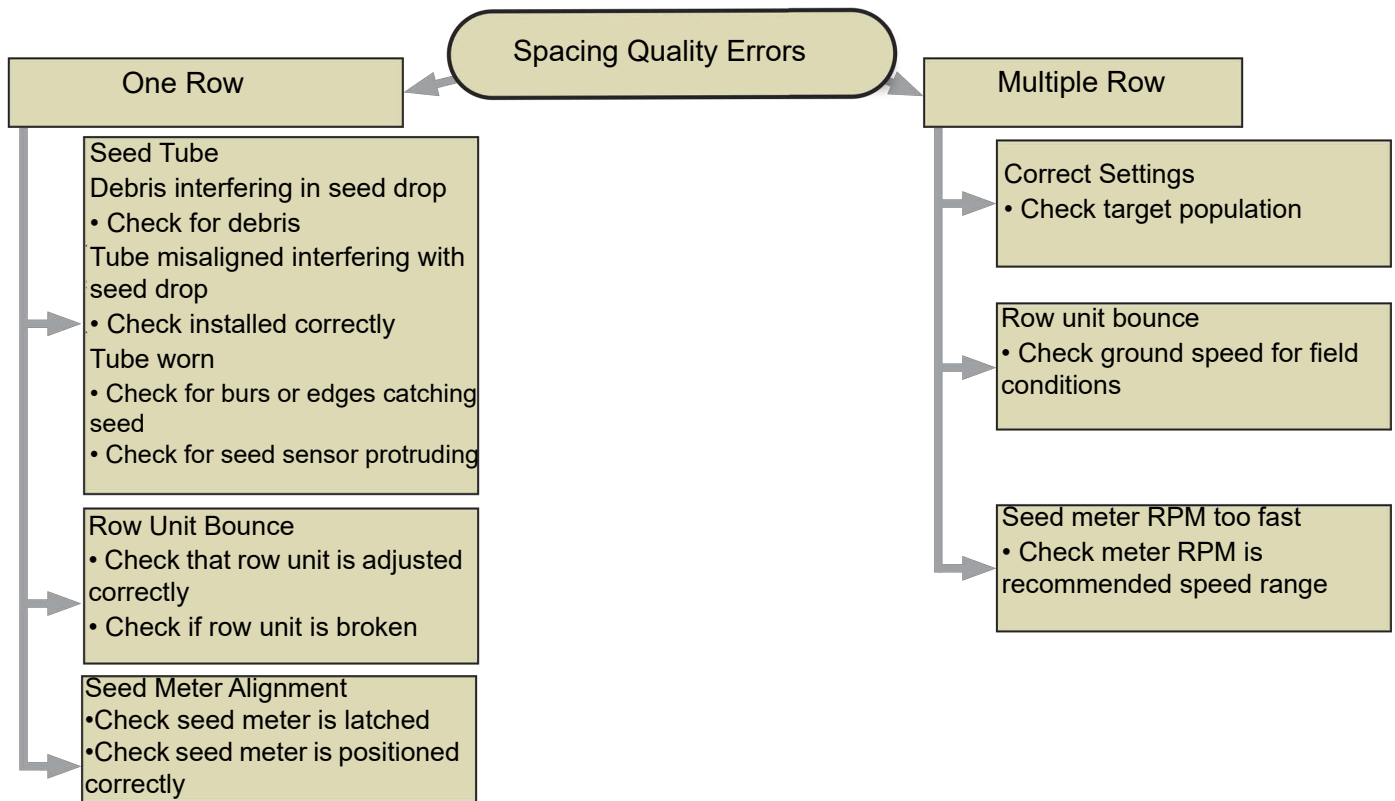

Disclaimer:  
Consult planter Operator's Manual when adjusting

**SEEDCOMMAND - RCM, ROW UNITS ELECTRICAL**

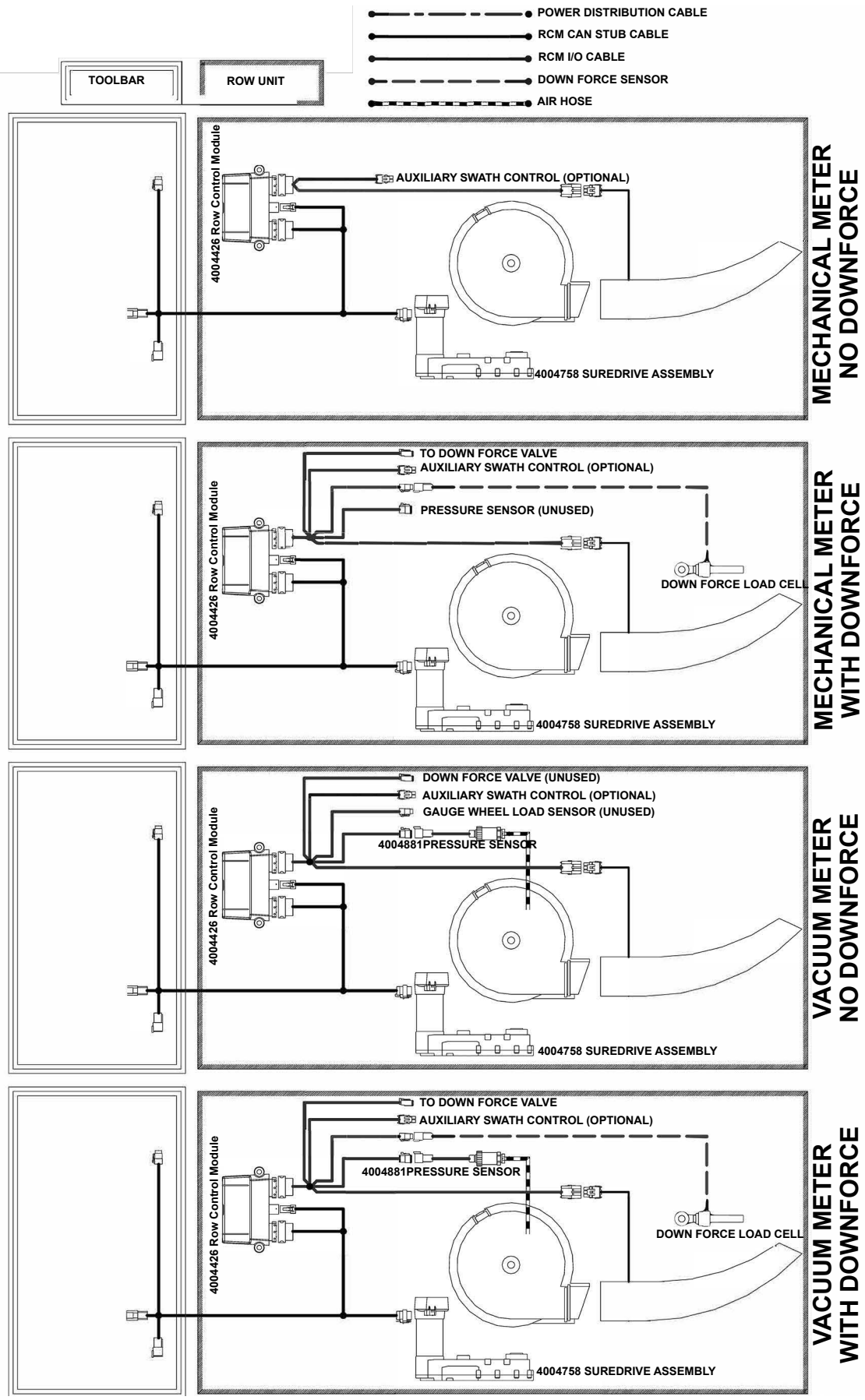





## SureSpeed®

SureSpeed is a complete high-speed, high-accuracy planting solution with superior performance at any speed up to 12mph. It consists of a 24v electrically driven meter, and delivery tube to carry seed all the way to the ground while controlling seed population, singulation, section control, turn compensated rate control, and a variety of other planter functions.



**NOTE!** If a planter has narrow rows (less than 30 inch row spacing) Ag Leader recommends grouping the outer planter sections together as a single swath section. Due to GPS drift, sections less than 30 inches may be turned on and off by AutoSwath™ when planting next to a covered area.

## Load Configuration



Press the Planting App from the home screen. This will take you through the steps needed to load a configuration.



**NOTE!** SureSpeed requires a CANbus buad rate of 500kbps. The below message will appear and require a display restart if the system CANbus is not running on 500kbps.

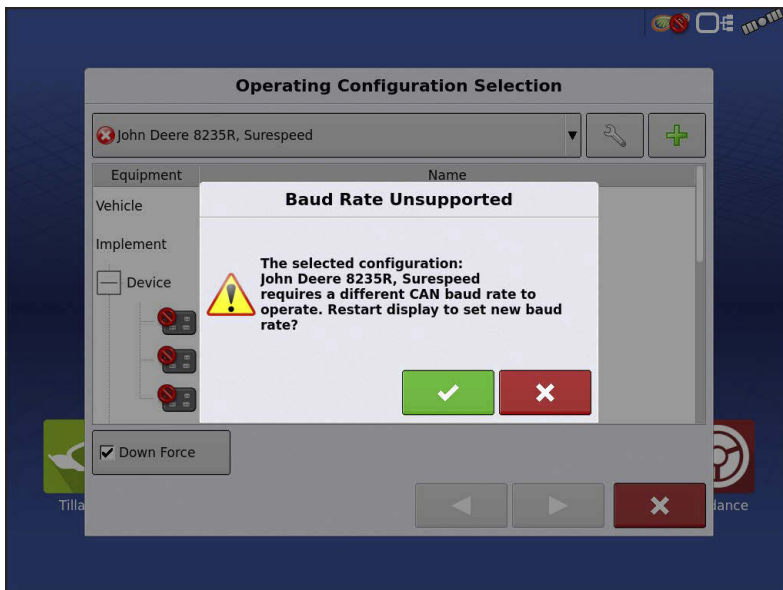

To set the CANbus back to 250kbps uncheck:

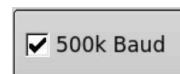

located in the Advanced Setting tab under Console Setup.

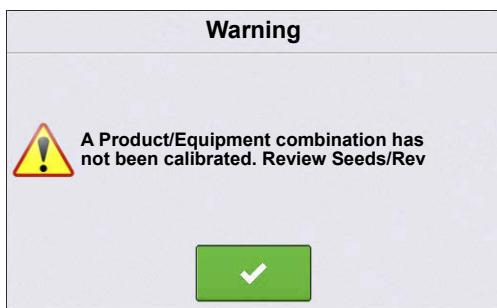

**ATTENTION!:** If a configuration is loaded for the first time, the user will be presented with a warning message indicating that the Seeds/Rev setting needs to be reviewed. Proceed to the Planter Options screen to enter the appropriate Seeds/Rev value, see [Planter Options on page 469](#).

The Seeds/Rev value is required in order to control the planter rate. (If the Seeds/Rev value is left at 0, this warning message will appear each time an Event is created/continued.)

## Map View

Once a configuration has been completed, the Map View screen appears.

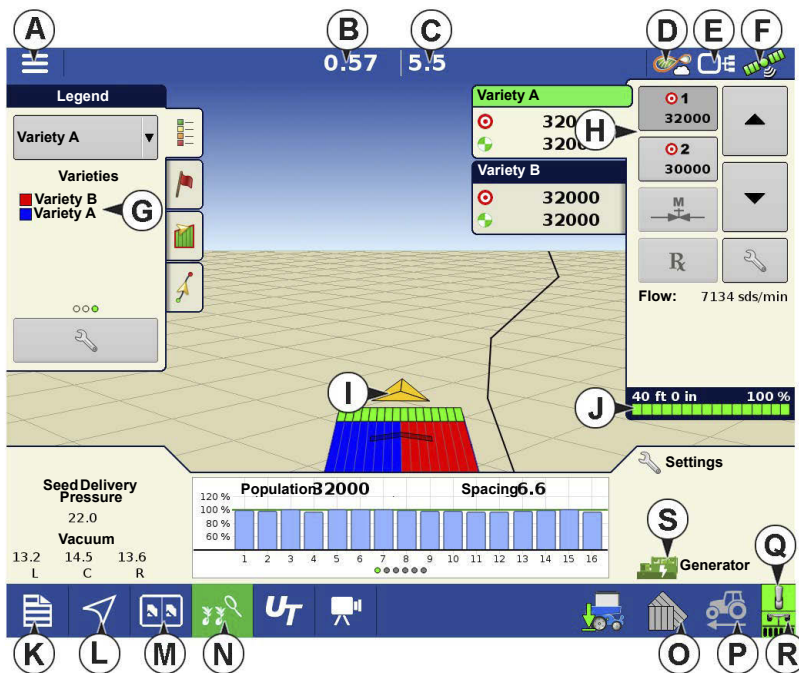

- A.Menu button
- B.Total Logged Field Area
- C.Ground Speed
- D.AgFiniti® Status
- E.Diagnostics
- F.GPS Signal Indicator
- G.Display Legend
- H.Product Control toolbox
- I.Vehicle Icon
- J.Section Status Indicator
- K.Event Summary

- L. Map View
- M. Split screen
- N. Advanced Seed Monitoring
- O. AutoSwath
- P. Jump Start
- Q. Master Switch Status

R. Implement Switch

S. Generator Status Indicator



**NOTE!:** Pressing the Map View button will cycle between the available Map Screen views, and the appearance of the Map View button changes.

### Product Control Toolbox

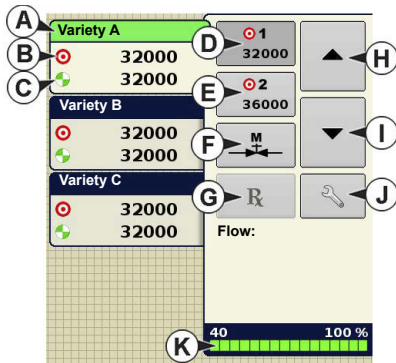

During SeedCommand® Run Time operations, the Product Tabs are shown in the upper right-hand side of the Map screen. Press the Product Tabs, and an extended view shows the Rate buttons, Manual Valve Control button, Prescription button, Rate increase and decrease arrows, and the Rate Setup button, all of which are described below.

a. **Variety**—The Product Control Toolbox can show rates for multiple varieties, depending upon the particular planting configuration. Press the area of the box that shows a particular variety, and a green bar highlights that variety. The Rate 1 and Rate 2 are then shown on the Rate buttons.



b. **Target Rate**—The Target Rate is the desired planting rate.



c. **Actual Rate**—The Actual Rate is communicated by the shaft rotation sensor.



**NOTE!:** In some conditions, the Actual Rate may increment slower than the Target Rate, or its numeric values may vary before matching the Target Rate.



d. **Rate 1 button**

e. **Rate 2 button**

The Rate 1 and Rate 2 settings represent preset planting rates that allow operators to quickly change between desired planting rates for each individual product. The active rate button appears with a gray background behind it. In the example above, Rate 1 is active.



f. **Manual Rate Control button**

R  
28000

g. Prescription button

h. Rate Increase arrow 

i. Rate Decrease arrow 

Pressing once on  /  increments the rate according to the user-defined amount on the Rate Control Settings screen.



j. **Rate Setup button**—The Rate Setup button opens the Rate Control Settings screen.





k. Section Status Indicator

## Rate Control Settings



Press Settings button to adjust the Rate 1 and Rate 2 settings shown at the Product Control Toolbox on the Map screen, as well as import planting prescriptions. To access the Rate Control Settings screen, press the Rate Setup button on the Product Control Toolbox.

The Rate Control Settings screen appears.

- The **Rate 1** and **Rate 2** settings represent preset application rates that allow operators to quickly change between desired target rates for each individual product. Press  to enter the desired amount.
- The **Increment** button allows operators to specify the increase or decrease amounts for a specified rate when using  /  on the Product Control Toolbox. Press  to enter the desired increment.



To load a map-based prescription file, press .

## Turn Compensated Rate Control

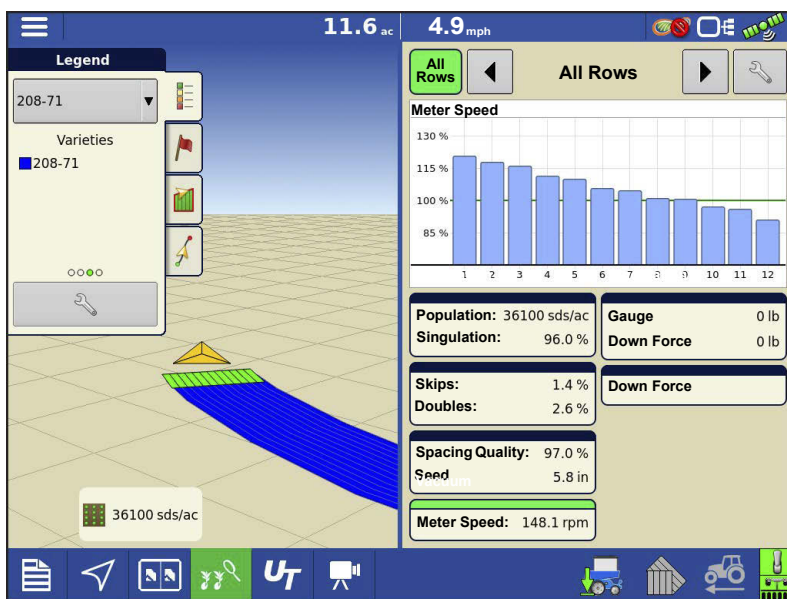





When planting through a turn or curve, the forward speed at each end of the planter can drastically change.

SureSpeed has the capability to plant at the desired target population on all rows while making a turn. The SureSpeed on each row will automatically adjust its RPM up or down to achieve the correct plant population at any given time. The Turn Compensation feature does not need

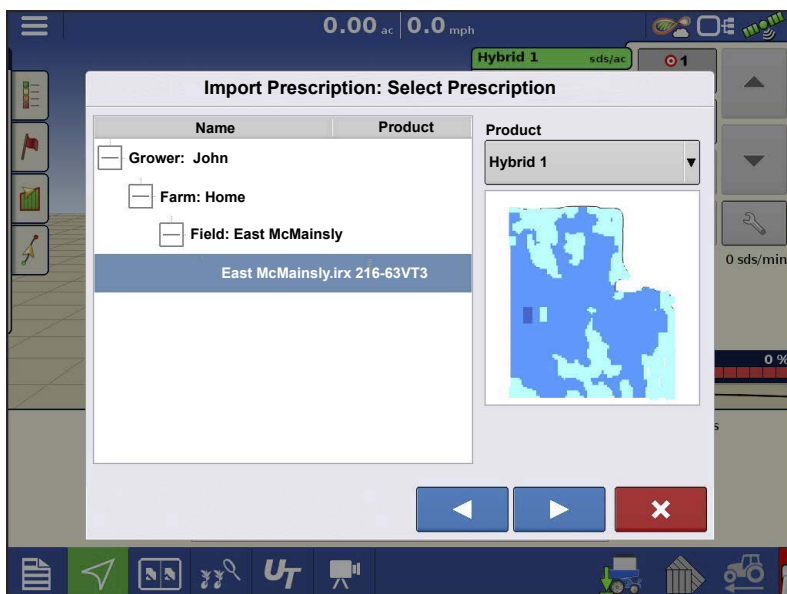
to be enabled; this feature will automatically work once planting occurs.

## Loading Prescriptions



1.  Press the Rate Setup button on the Product Control Toolbox.
2. Press the **Load Prescription**  button.
3. Using an inserted USB or AgFiniti Cloud, search for and highlight the correct .agsetup, .irx , or shape file and press .

4. Select the prescription in the Select Prescription screen, and select the correct controlling product from the Product dropdown box. A preview prescription map is displayed. Press

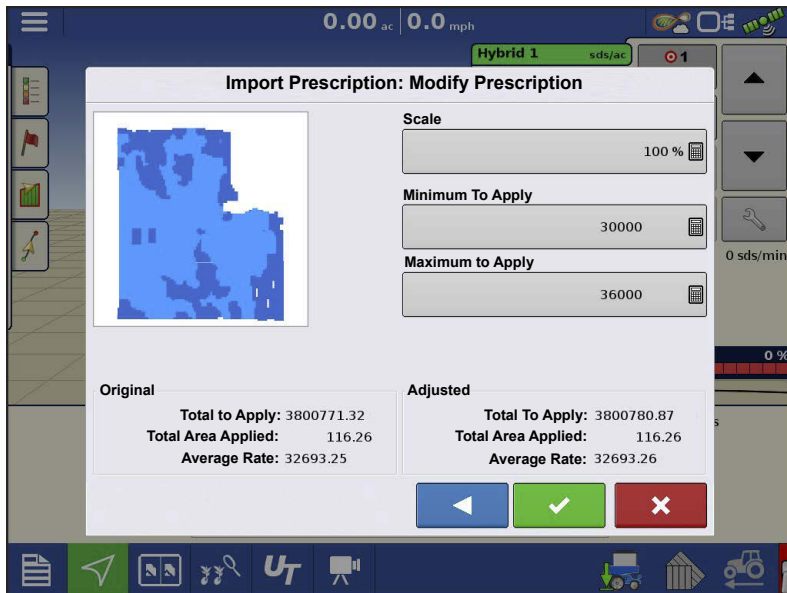

5. In the Modify Prescription Screen the prescription scale, minimum to apply, and maximum to apply can be changed. As the three parameters are changed, the adjusted total to apply and average rate will update accordingly.

6. Press the .

7. After returning to the Mapping Screen, the prescription will appear on

the map while in a North Oriented view.

## Shape File Conversion

What is commonly called a shape file is actually a collection of three different files. All three of the files are required and must be present on the USB drive for the system to use shape file groups for variable rate product application. A single "shape file" can contain recommendation rates for multiple products.

1.  Press Setup button on the Product Control Toolbox.



The Rate Control Settings screen appears.

2.  Press the **Load Prescription** button.

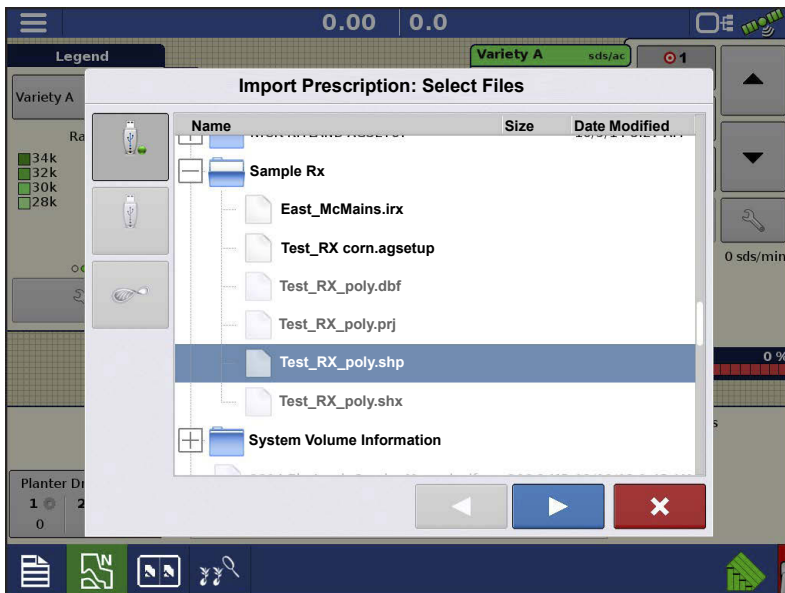

3. The **Select File** screen appears. Highlight your desired .shp file and press .

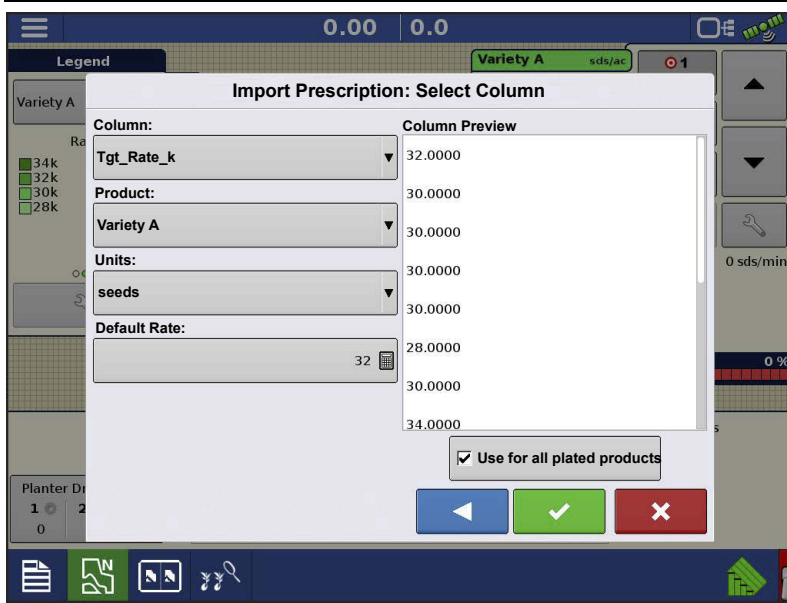

#### 4. Select **Column** From Shape File

Select the column that contains the product recommendation rate. The list on the right side of the dialog shows sample data from the selected column.

#### 5. Select **Units**

Select the controlling units for product application.

#### 6. **Default Rate** Setting

The system assigns a default rate. Use the on-screen keypad to edit the value if desired.



**NOTE!:** Select the product and units that the shape file prescription was made for. Selection of the wrong data column or unit will result in misapplication of product.



**ATTENTION!:** The only time the default rate is used by the system during product application is if the Rate Outside of Field selection is set to "**Rx default**". This setting is located in the equipment configuration settings portion of configuration setup. If the Rate Outside of Field selection is set to "Rx default", the default target rate will be used when the vehicle exits the area covered in the prescription map.

## Advanced Seed Monitoring

### Bar Graph

Swiping left or right will toggle the bar graph between all the following seed placement performance graphs.

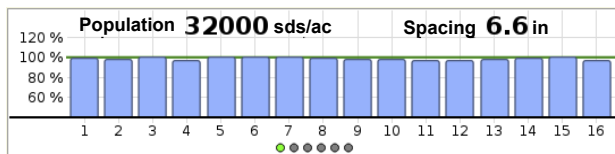

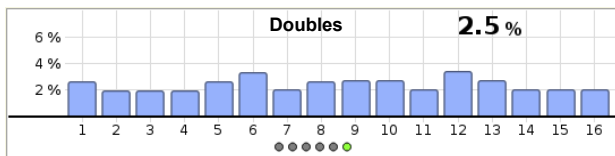
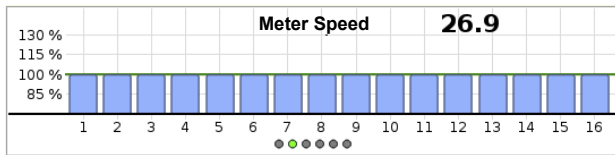
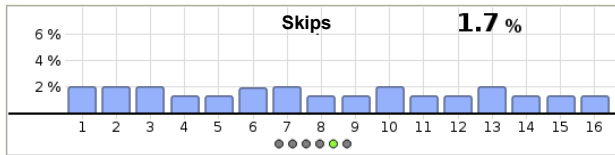
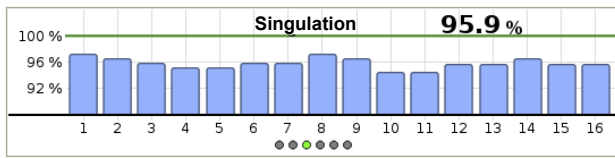

## Advanced Seed Monitoring



Press: Advanced Seed Monitoring button.

## Planter Performance screen

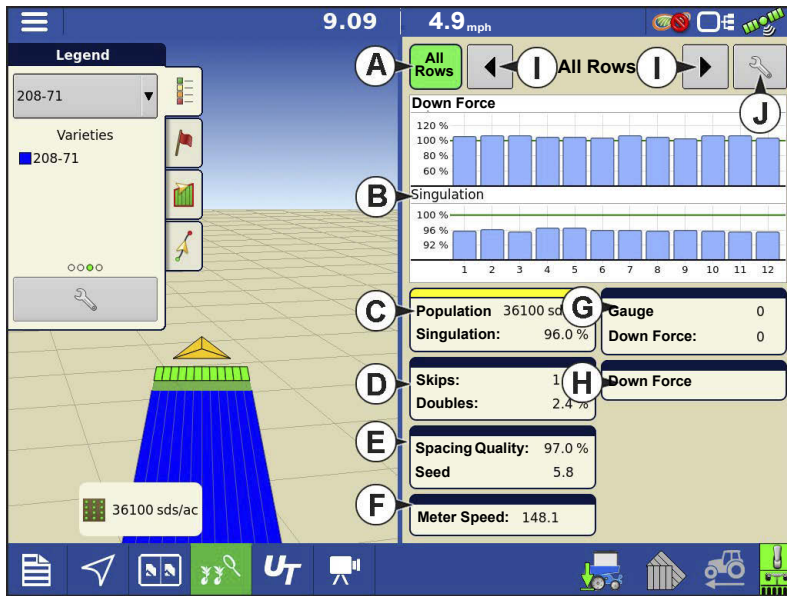

- A.All Rows
- B.Bar Graph
- C.Population/Singulation
- D.Skips/Doubles
- E.Spacing Quality/Seed Spacing
- F.Meter Speed
- G.Gauge Wheel/Down Force
- H.Down Force Trends
- I.Previous/Next Row Toggle

### J. Seed Monitor Options

Advanced Seed Monitoring provides planter performance monitoring of seed meter singulation, skips/doubles and spacing quality, along with population and spacing information for all rows when planting compatible crops.

In addition, Advanced Seed Monitoring automatically determines and displays the rows operating at the highest and lowest levels for singulation and population. The screen also shows the averages for specific drive sections.

Bar graph can show individual row information for the averages shown on buttons (C, D, E, G, H).

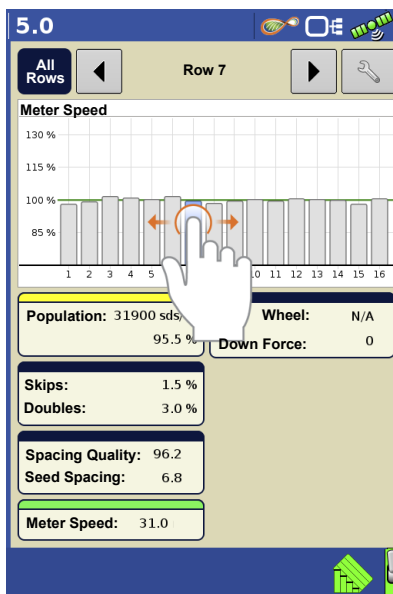

**A.All Rows**—Planter average for display items (C, D, E, G, H) at the bottom of the screen.

**B.Bar Graph**—Displays population, singulation, spacing quality, skips, and doubles, as selected by the operator.



**NOTE!** An operator may also touch the appropriate bar on the graph to show that specific rows Advanced Seed Monitoring values. To easily change between specific rows, tap and hold your finger on the bar graph, then drag left or right between rows. Release your finger from the screen when the desired row is highlighted.

---

C. **Population**—Displays the average population for the planter, or sections of the planter, along with the highest and lowest population row.

**Singulation**—Displays the average Singulation for the planter, or selected sections of the planter, along with the highest and lowest rows.

- Singulation is a measure of the percent of seeds being properly metered so that one and only one seed drops from each seed cell of the seed meter.

D. **Skips/Doubles**—Displays the average skips and doubles for the planter

- Skips are a measure of the percentage of seed expected to be planted that are not due to a seed not being dropped by the seed meter.
- Doubles are a measure of the percentage of seed expected to be planted individually but instead two or more are dropped by the seed meter.

E. **Spacing Quality**—Displays the average spacing quality for the planter, or selected sections of the planter, along with the highest and lowest.

- Spacing quality is a measure of the percent of seeds being properly placed so that the spacing is as expected in the seed trench.

F. **Meter Speed**—Displays row by row meter speed

G. **Gauge Wheel/Down Force**

H. **Down Force Trends**

I. **Previous/Next Row Toggle**—Toggle through the rows using the arrow buttons or press on a specific row in the bar graph to show specific Advanced Seed Monitoring values for that row.



J. **Seed Monitor Options**—Pressing this button brings up Seed Monitor Options screen.

## Creating Products

Creating planting products can be completed during initial setup or from the Product Selection screen of the Field Operation Wizard when starting a field operation.

Follow described steps to create planting varieties during initial setup.





**Variety Setup Wizard: Variety Name**

Enter Variety Manufacturer and Name

Variety or Hybrid Manufacturer  
 None 

Variety or Hybrid Name  
 Corn 

Advanced Seed Monitoring

1. Select **Product Type** (Crop) and **Product Units** (seeds or pounds).

2. Enter **Variety** or **Hybrid** name.

Press  to enter a unique name for the variety or hybrid.

3. Enter **Variety** or **Hybrid Manufacturer** is applicable.

Manufacturer name can be added to the drop-

down menu by pressing .

Check Advanced Seed Monitoring (ASM) to enable ASM Stats on the run screen when using this product.

ASM may not be display appropriately if the product is applied at very high rates.

4. Press  to complete Product setup.

Created variety or hybrid should appear under the Planting heading located on the Product tab of the Configuration Setup Screen.

## Create Configuration

A wizard will guide you through the process of selecting or creating a configuration with application settings.

The configuration can be started in two places:



OR



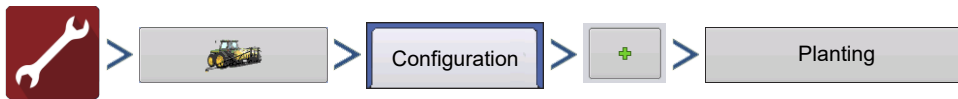

Your Operating Configuration will then be viewable when you start a new Field Operation.

You can also use the **Manage Equipment** button to create or edit specific vehicles and implements.

## Planter Options



### Seed Monitor

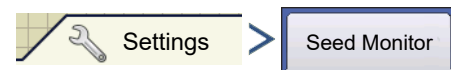

OR

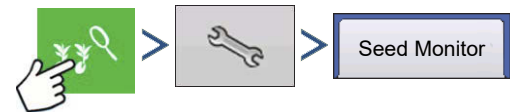

In the **Seed Monitor** tab you can adjust Seed Monitor alarm

thresholds, Gain, and Advanced Seed Monitoring alarm thresholds. The screen also has access to module Diagnostics.

**Gain** shows the population multiplier used to adjust the population if the seed sensor is not sensing the actual seed population.

- Gain will not be changed when using SureSpeed.
- Always start with the Gain set to 1.
- Gain Setting is saved by crop type.
- For Corn, Gain values should **always** be set to 1.

**Gain adjust example:** Planting soybeans at a target population of 150,000, the on-screen population readout is 140,000. First perform a dig check to verify the correct population is being planted; then check the seed tube sensors to make sure they are clean of dust and debris. Once the checks have been done, the Gain can be adjusted so the on-screen population readout

reflects the true population. Divide the target population by the population readout (150,000 / 140,000 = 1.07). Enter 1.07 as the new Gain value.

### Advanced Seed Monitoring Thresholds

- Singulation Alarm
- Spacing Alarm

Advanced Seed Monitoring supports any crop running less than 60 seeds per second.

For example: A planter using 30” spacing, at 6mph could plant up to 120,000 seeds per acre. Planting above this rate would result in no Advanced Seed Monitoring stats.”



**WARNING!:** Do not change the Default Gain setting of 1 for any crops that are monitored by Advanced Seed Monitoring.

### Population Alarms

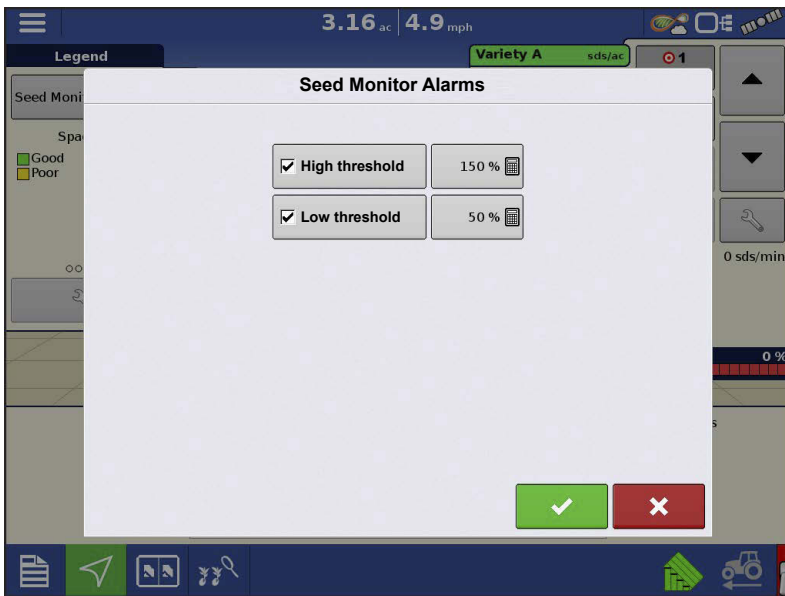

Adjust seed monitoring alarm thresholds. This screen can be accessed in one of two ways:

- Pressing the **Population Alarms** button at the Planter Option screen.

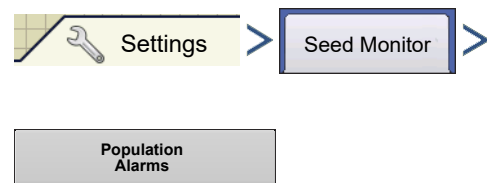

OR

- Pressing the **Population Alarms** button at the Seed Monitor Setup screen.



**High threshold** and **Low threshold** check boxes allow a percentage of error to be assigned that will trigger the rate alarm. Unchecking the High and Low threshold will disable that specific alarm. Population will still be displayed in the planter performance graphs.



**Sensor Configuration**—From this screen you can disable a specific row’s seed tube sensor. This will disable all alarms, and that row in the planter performance graphs.

## Vacuum & Pressure Configuration



If Air Seed Delivery or row Vacuum sensors are installed, you must configure them from this screen. Highlight the appropriate Row, then press **Install**. (This will also calibrate the vacuum sensor. Be sure to have the vacuum systems turned OFF.)

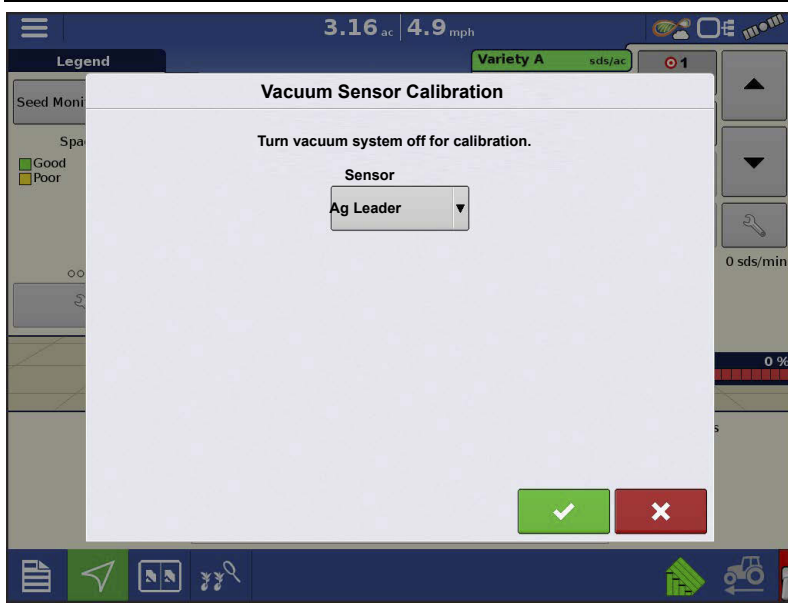

In the next screen select the Sensor Type. Select **Ag Leader** for all sensors provided by Ag Leader. Select **Generic** for all other type of sensors.

**NOTE!** If a **Generic** sensor type is selected, the sensors Slope value must be known. The Slope value is in units of mV/inH<sub>2</sub>O (mV/mbar).

## Planter Drives

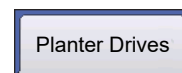
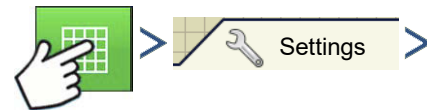
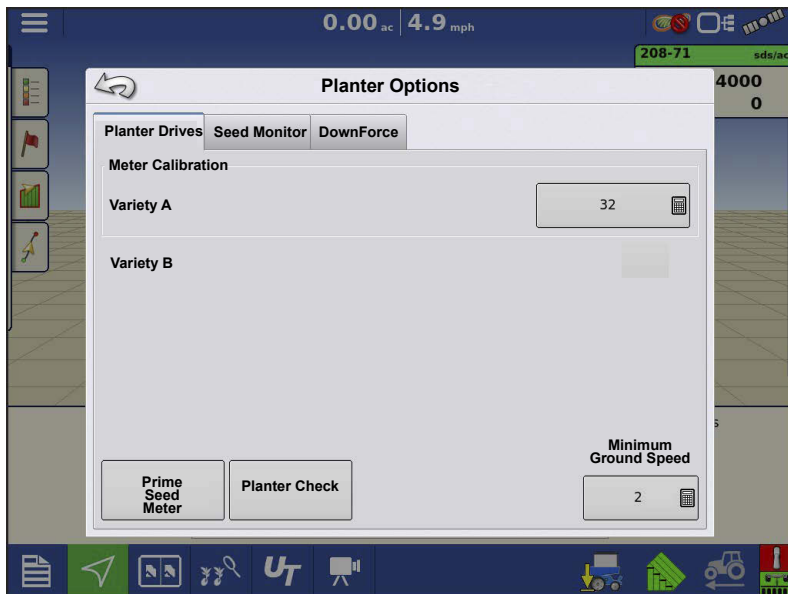

OR



In the Planter Drives tab the sds/rev can be set, the seed meters can be Primed, and the Minimum Ground Speed can be set.

**Minimum Ground Speed**—The planter will plant at this simulated ground speed, until displayed ground speed is above this value. This fixed ground speed compensates for delays in acquiring

an initial ground speed when starting from a stand still. Planting at the minimum ground speed will occur when the jump start button is pressed. Once the Jump Start button is pressed, it will remain active for 10 seconds, or until pressed again.



A. Jump Start **Not Active**



B. Jump Start **Active**

## Priming Seed Rate Meters

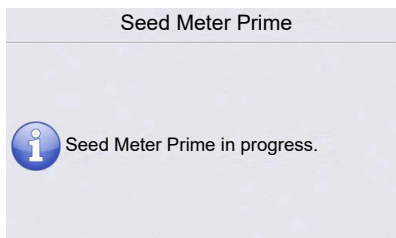

The Seed Meter Prime is used to charge the seed meter when filling with seed.

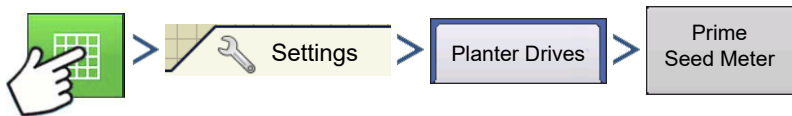

OR

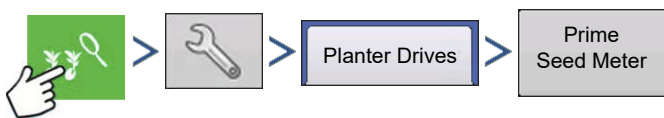

A message displays, stating “Seed Meter Prime in Progress.” While this message displays, the seed meter will turn one (and only one) revolution automatically. When complete, return to the Planter Options screen.

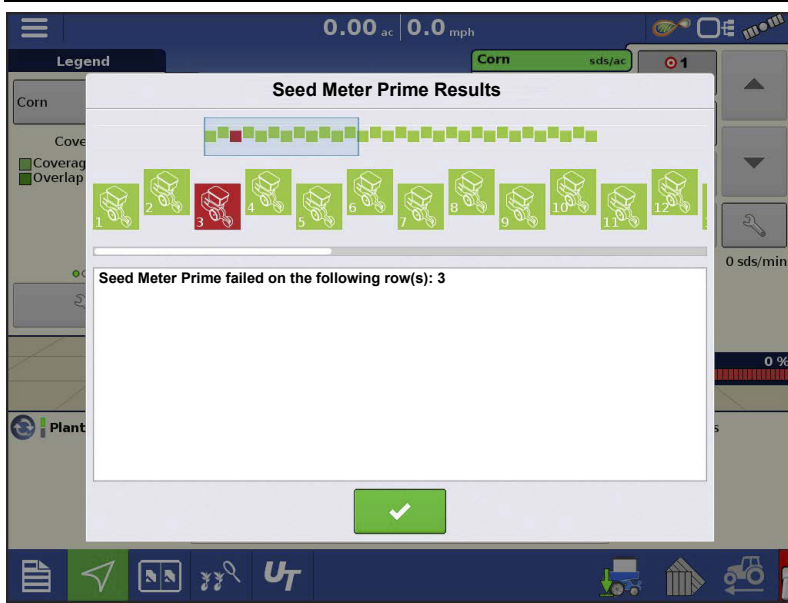

If a row fails to prime the operator will be presented with a “Seed Meter Prime Results” screen indicating which row(s) has failed. A failed meter prime will occur if the meter does not turn the 1 full revolution. Inspect the meter and seed meter if this occurs, and prime the meters again if necessary.

## Planter Check

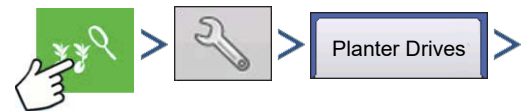
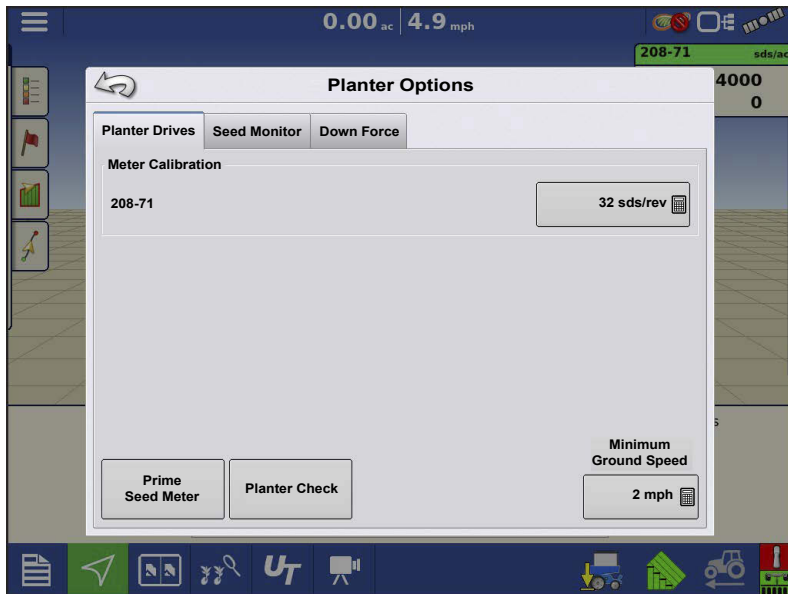

The Planter Check feature is used to verify functionality of the SureSpeed Meter and Delivery System."

During the Planter Check the system will attempt to turn the SureSpeed Meter Motor and Delivery Motor, and monitor encoder feedback to verify readings are within an acceptable

range.

 **NOTE!:** The Planter Check is intended to be run without seed in the meter.

### Planter Check Success



## Planter Check Failure Detected



## Planter Test Stand

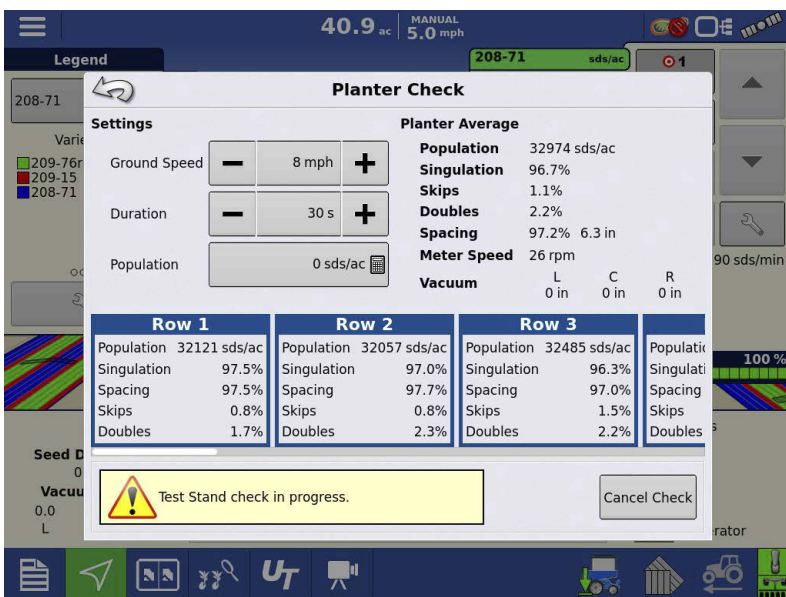

The planter test stand feature is selected from the bottom right of the Planter Check screen.

The planter test stand feature allows the user to set the desired speed and population and view meter performance on each row. This is done with seed in the hopper and the vacuum system on.

The user can use these readings to help make decisions on what

adjustments need to be made to ensure meters are performing at the optimal efficiency.



Agl		 <b>Test Stand Report</b>						
<b>Parameters</b>				<b>Hybrids</b>				
Planter: John Deere 8245R, Surespeed plant				1197 AM 32 sds/rev				
Ground Speed: 8.0 mph				1366 AM 32 sds/rev				
Duration: 30 s				1396 AM 32 sds/rev				
Target Population: 32000 sds/ac								
Test Date: 12/07/2020 5:00 PM								
<b>Planter Average</b>								
	<b>Population (sds/ac)</b>	<b>Singulation (%)</b>	<b>Skips (%)</b>	<b>Doubles (%)</b>	<b>Spacing Quality (%)</b>	<b>Spacing (in)</b>	<b>Meter Speed (rpm)</b>	
	32150	99.2	0.5	0.3	99.4	6.5	40.375	
<b>Row Summary</b>								
<b>Row</b>	<b>Population (sds/ac)</b>	<b>Singulation (%)</b>	<b>Skips (%)</b>	<b>Doubles (%)</b>	<b>Spacing Quality (%)</b>	<b>Spacing (in)</b>	<b>Meter Speed (rpm)</b>	<b>Vacuum (in)</b>
1	32047	99.3	0.2	0.5	98.8	6.5	40	0.0
2	32156	99.3	0.0	0.7	99.0	6.5	40	--
3	32096	99.2	0.2	0.7	99.2	6.5	40	--
4	31953	99.7	0.2	0.2	99.0	6.5	40	--
5	32265	99.0	0.0	1.0	99.7	6.5	40	--
6	32314	98.5	0.3	1.7	98.8	6.5	40	--
7	31960	100.0	0.0	0.0	99.8	6.5	40	--
8	31902	99.8	0.2	0.0	100.0	6.5	40	--
9	31757	99.0	0.8	0.2	99.3	6.6	40	--
10	31558	98.2	1.5	0.5	98.8	6.6	40	--
11	32034	98.0	0.7	1.5	98.7	6.5	40	--
12	32000	97.8	1.0	1.3	99.3	6.5	40	0.0
John Deere 8245R, Surespeed plant_170037_2020_12_07.pdf								
Page 1 of 1								

After running the planter check a reported will be made that can be exported as a pdf to print off or view later.

## Legend Setup

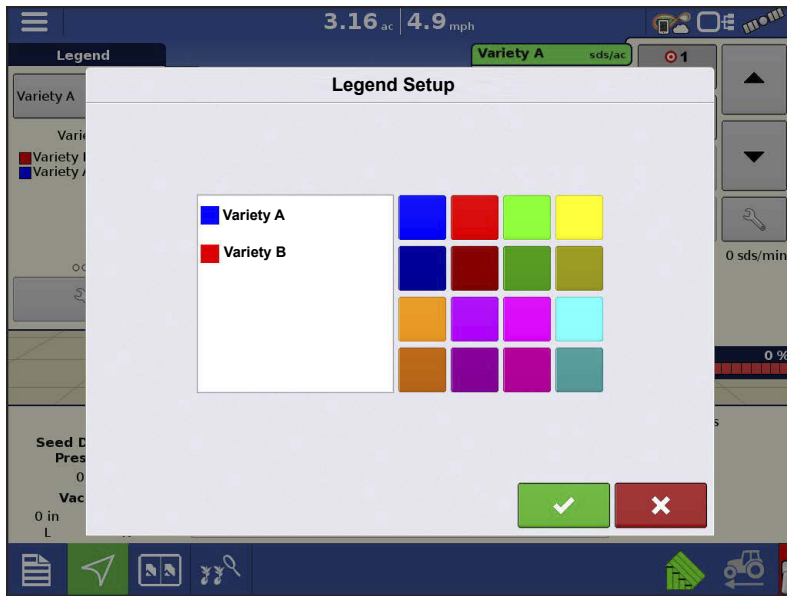

when finished.

Pressing the area under the seed varieties on the Map Legend Tab of the Mapping Toolbox opens the **Legend Setup** screen.

If a variety was selected, a list appears on the left-hand side of the Legend Setup screen. To change the color of one of these varieties, highlight that variety and then press a color on the color palette at right. Press 

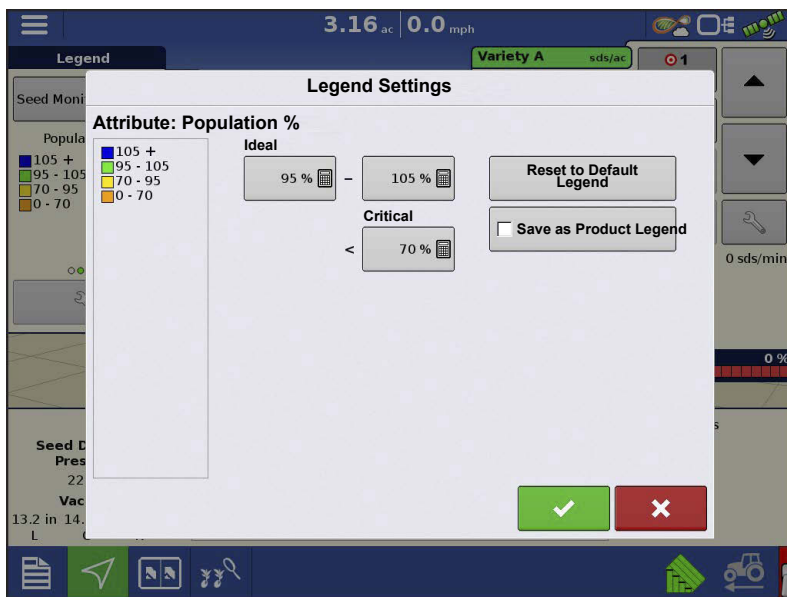

If Seed Monitor was selected, the **Legend Settings** screen appears (similar to the screen to the right). Use this screen to adjust the legends thresholds. Legend settings screen may differ depending on the legend that is displayed. There are legend settings for Population, Population %, Singulation, and Spacing. Press  when finished.

## Seed Rows

This feature enables creating and using configurations to plant male and female varieties.

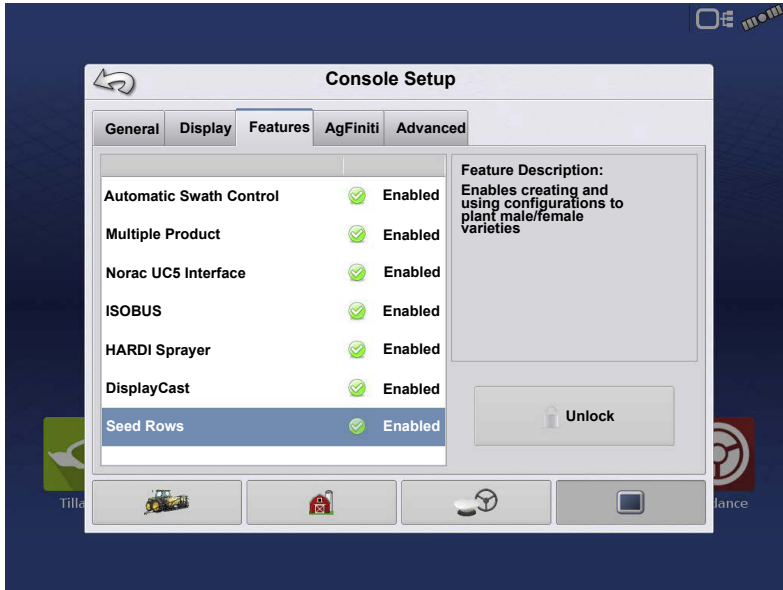

To utilize this feature a **Seed Rows** unlock and **Multiple Product** unlock must be purchased and entered in the display. The Feature Tab is where you can enter unlock codes. Unlock codes are unique to the serial number of each display and the feature registration number. You must supply these numbers to your dealer when purchasing any unlock codes. Press



to enter the unlock code and

press  to enable the feature.

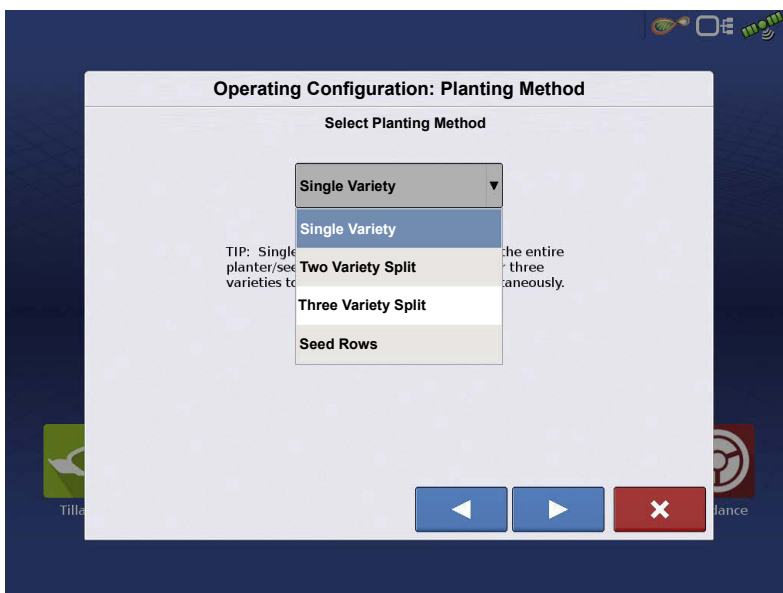

A new configuration must be created to begin using this feature.

1. In the configuration wizard on the **Operating Configuration: Planting Method** screen, **Seed Rows** must be selected from the drop down list.

Press  .

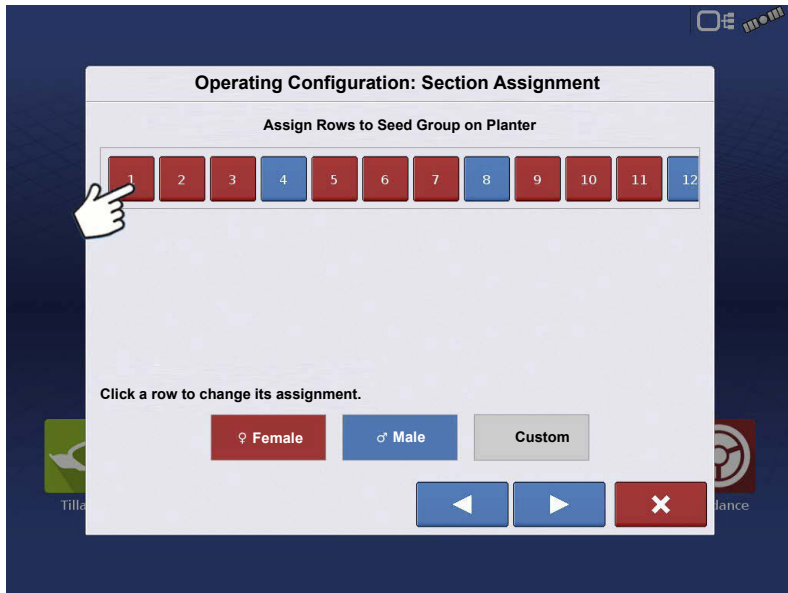

2. In the **Section Assignment** screen assign row to the appropriate seed group; **Male**, **Female**, or **Custom**. Each row can be toggled between all three group options. Press . Complete the configuration.

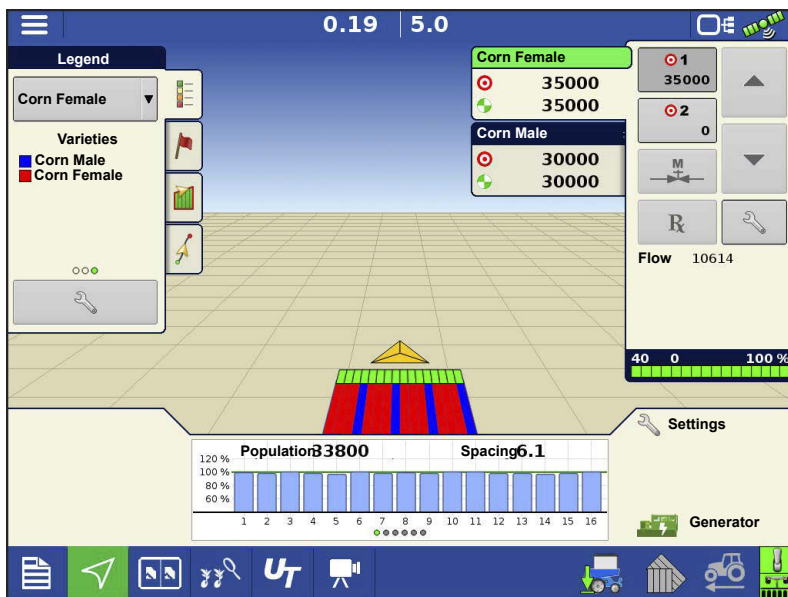

With the operating configuration loaded to the Map View Screen, the Male, Female, and Custom assigned rows will map as three separate varieties; with the ability to also enter individual planting rates for each variety.

 **ATTENTION!:** When three different target rates are entered, the actual population displayed in the map

screen bar graph and Advanced Seed Monitoring screen will represent a weighted

---

average over the planter rows. Seed Spacing and Meter Speed will also be represented as an average.

Singulation, Skips, Doubles, and Spacing Quality will be represented accurately since they are displayed as a percentage.



**NOTE!:** Section assignment will default the female rows to Switch 1, the male rows to Switch 2, and the custom rows to switch 3. The section assignment can be viewed or edited in the Auxiliary Input screen.

## Automatic AutoSwath Control

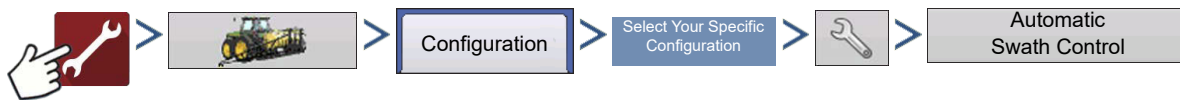

OR

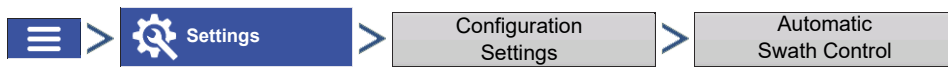

**NOTE!:** To use AutoSwath for planting operations, you are required to use a 5 Hz or higher GPS output rate. AutoSwath control will not allow sections to be turned on until the master and planting section switches are on. If you have less than a 5 Hz GPS output rate and you select AutoSwath, a warning appears, telling you that AutoSwath Control is not available at less than 5 Hz.

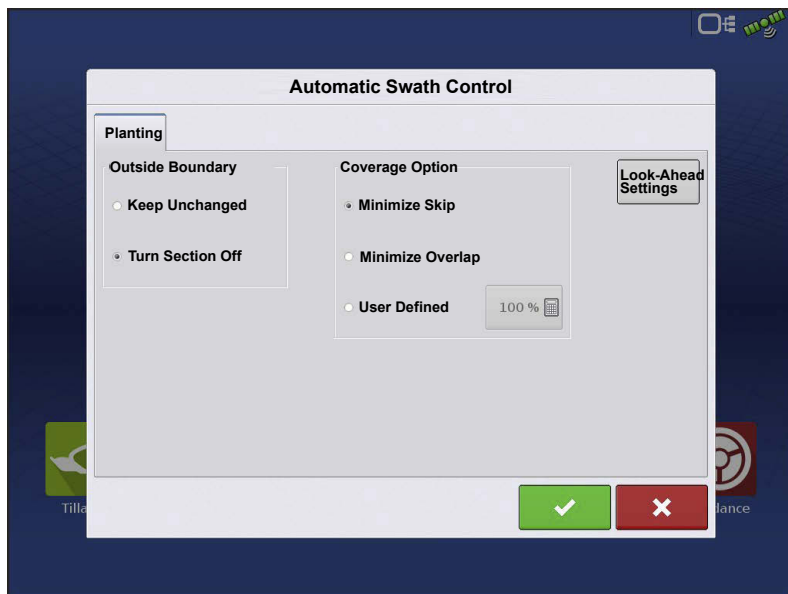

The Automatic Swath Control feature turns sections off and on automatically based upon the following conditions:

- Entering and exiting internal and outer field boundaries.
- Entering and exiting previously-applied areas within a field.

**Outside Boundary Option**—Select one of the two options to determine system behavior when a section exits

a field boundary.

- **Keep Unchanged**—Swath section on/off status will not change when exiting the field as defined by the outside boundary.
- **Turn Section Off**—Swath section will cease planting when exiting the field as defined by the outside boundary.
- **Coverage Option**

In the Coverage Option area, you must choose between three options:

- The **Minimize Skip** option turns off the swath section after the entire section is fully inside your coverage area. This prevents the possibility of skips.
- The **Minimize Overlap** option turns off the swath section when that section first enters your coverage area. This prevents the possibility of overlaps.
- The **User Defined** option allows you to choose what percentage of the swath section is within the coverage area before that section turns off. For example, if you choose 50%, then the section will switch off when half of it is within your coverage area.

## Look-Ahead Settings

AutoSwath Control settings are saved per controller per configuration. There can be different Look-Ahead settings saved for equipment of the same operation. The Look-Ahead Settings screen will contain every controller's Look-Aheads.



On the AutoSwath Control screen, press the Look-Ahead button.

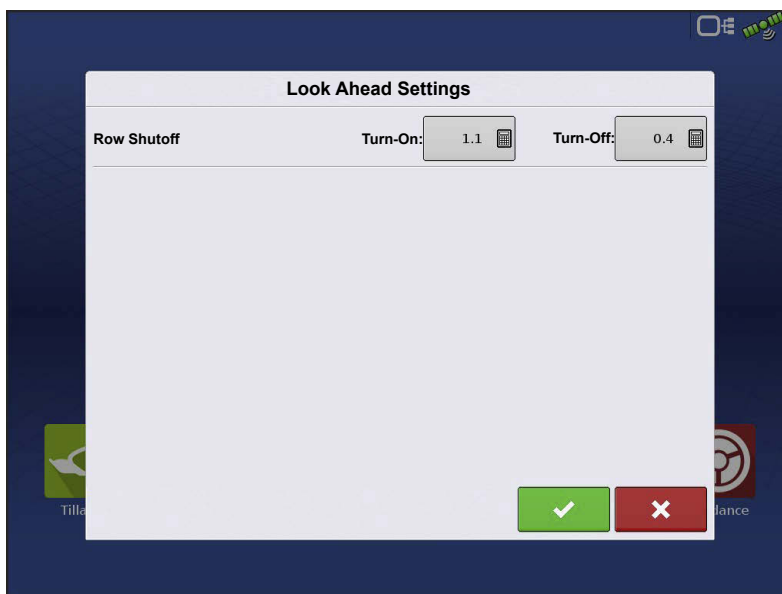

**Turn-On**—This setting determines how far ahead the system looks to turn the sections back on. This setting compensates for delay in the planting control system when the implement sections are turned on.



**ATTENTION!** For best performance, do not change travel speed as you are entering the unplanted area. Accelerate either well

before entering the unplanted area, or after all clutch sections have turned On.

**Turn-Off**—This setting determines how far ahead the system looks to turn the sections off. This setting compensates for delay in the product control system when the sections are turned off.



**ATTENTION!:** For best performance, do not change travel speed as you are nearing the planted area. Decelerate either well before entering planted area, or after all clutch sections have turned Off.



**NOTE!:** Using the default settings should produce good field results. However, always take the time to check for proper seed placement in the field and make system setting adjustments as needed. Do not rely solely upon the appearance of the On-Screen map. The on screen map will not show gaps and overlaps caused by incorrect GPS Offsets or AutoSwath Look-Ahead settings.

## Configuring Offset Planter Sections



OR

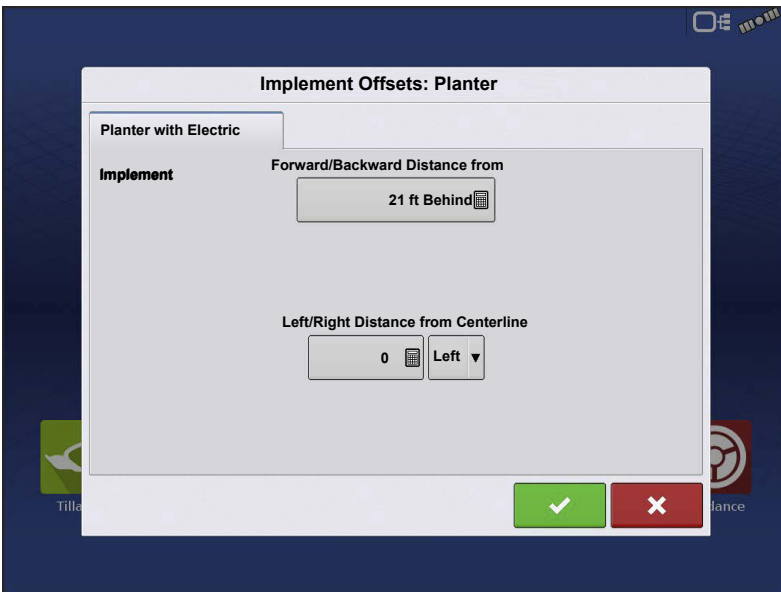

Implement Offsets screen appears.

Defaults to the value entered during Configuration Wizard.

Planter sections can independently be offset forward or back.

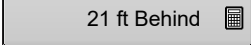
1. Press  to access Swath Section Offsets screen.



	Width	F/B Offset	L/R Offset
8	2.500	21.000	11.250
9	2.500	21.000	8.750
10	2.500	21.000	6.250
11	2.500	26.000	3.750
12	2.500	26.000	1.250
13	2.500	26.000	1.250
14	2.500	26.000	3.750
15	2.500	21.000	6.250
16	2.500	21.000	8.750

2. Select Swath section to edit and press Edit button.
3. Enter Forward/Backward Offset for that specific section from hitch point.
4. Press  to enter change. Setup will indicate which offset is entered.

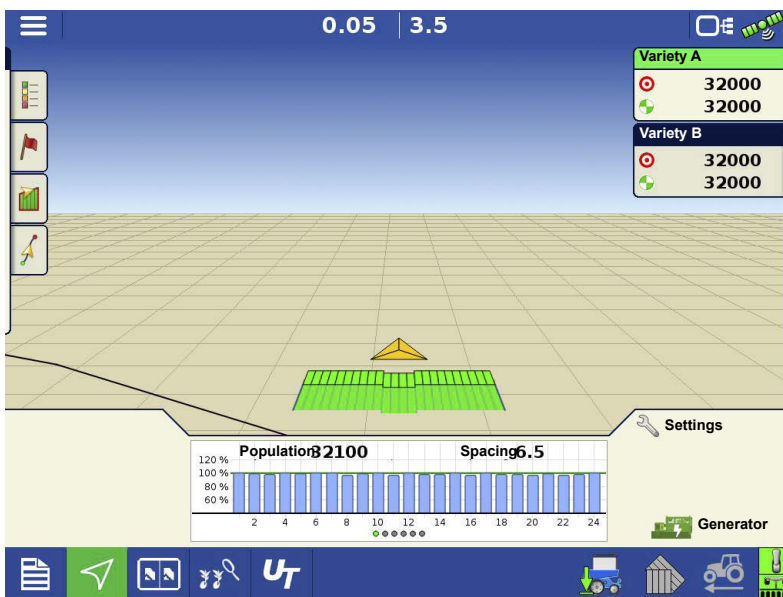

Runscreen reflects section offsets

 **NOTE!** If a planter has narrow rows (less than 30 inch row spacing) Ag Leader recommends grouping the outer planter sections together as a single swath section. Due to GPS drift, sections less than 30 inches may be turned on and off by AutoSwath when planting next to a covered area.

---

## Checking AutoSwath Performance for Row Shutoff

Always take the time to check for proper seed placement in the field and make system setting adjustments as needed. Do not rely solely upon the appearance of the On-Screen map. The on screen map will not show gaps and overlaps caused by incorrect GPS Offsets or AutoSwath Look-Ahead settings. Verify settings with the following procedure:

1. Stop the planter within 20 feet of the planted headland.
2. Select one row unit from each planter swath section to observe.
3. Remove the down pressure from the closing wheel of each selected row unit.
4. Hold the closing wheels off the ground by attaching a chain or strap from the hopper support panel to the closing wheel arm. (This prevents the closing wheels from closing the seed trench).



**NOTE!:** Securing these closing wheels up allows you to observe the planted seed in the trench so that you can observe when the AutoSwath is turned off and on during the seed application.

5. Resume planting in your normal fashion, then stop when you are 20 feet out of the headland of the next pass.
6. Stop the planter and observe the AutoSwath shutting off and turning on to see if the results are acceptable.
  - If the results are correct, then return the closing wheels to their previous operational state. Close the seed trench on the observed rows and return to planting.
  - If you suspect the results are incorrect, then adjust the appropriate Look-Ahead setting one-tenth (.1) second per trial. Larger adjustments can cause unintentional large changes in the AutoSwath's performance. When adjusting the Look-Ahead numbers from the suggested settings, it is recommended that you observe multiple trials to confirm the operations' accuracy.
  - If you encounter overplanting or underplanting problems, see "Fixing Overplanting and Underplanting in AutoSwath" below.

---

## Fixing Overplanting and Underplanting in AutoSwath

### AutoSwath Function—Turn Off Look Ahead

**Problem**—Underplanting

**Recommended Action**—Decrease Look-Ahead number

**Result**—The AutoSwath anticipates headlands later and turns the planter off later.

**Problem**— Overplanting

**Recommended Action**—Increase Look-Ahead number

**Result**—The AutoSwath anticipates headlands sooner and turns the planter off sooner.

### AutoSwath Function—Turn On Look Ahead

**Problem**—Underplanting

**Recommended Action**—Increase Look-Ahead number

**Result**—The AutoSwath anticipates headlands sooner and turns the planter on sooner.

**Problem**—Overplanting

**Recommended Action**—Decrease Look-Ahead number

**Result**—The AutoSwath anticipates headlands later and turns the planter on later.

### No Seed Flow - The seed sensor does not detect any seed flow.

**Problem**—On the affected row(s), engage the row using the magnetic diagnostic switch.

#### Recommended Action

- If there is seed flow, verify seed sensor is connected and clear of debris.
- If there is no seed flow, verify seed is present in the hopper and there are no blockages.
- Verify proper vacuum pressure
- Verify meter and delivery system are turning.

### SureSpeed Alarms

**Seed Meter Motor Communication** – Meter Motor drive is not communicating with the RCM.

#### Recommendation

- 
- Inspect cabling from motor to RCM
  - Verify LED is illuminated

**Seed Delivery Motor Communication Error** - Delivery Motor drive is not communicating with the RCM.

**Recommendation**

- Inspect cabling from motor to RCM
- Verify LED is illuminated

**Seed Meter Motor Stalled** – Meter Motor has stopped turning.

**Recommendation**

- Go back to the meter and engage the system using the magnetic diagnostic switch.
  - If the meter turns, but still throws this error the encoder may be damaged or not working.
  - If the meter does not turn, inspect the meter blockages that could prevent the meter from turning.
  - Verify whether the deliver tube is also turning. If the delivery tube is stalled as well the meter will not turn until the delivery tube is cleared of errors.

**High Meter/Delivery Tube Current** - Inspect Delivery Tube

**Recommendation**

- Stop immediately and inspect affected meter and delivery tubes for obstructions.

**Seed Meter Motor at Maximum Speed** – Meter at maximum speed (140 RPM).

**Recommendation**

- Verify the sds/rev value is correct in your Planter Operations screen.
- Verify the Target Rate is correct.
- Verify the display speed is accurate.
- Inspect your planter configuration and verify the number of rows and row spacing is correct.

- 
- Slow down or lower your planting rate.

**Seed Delivery at Maximum Speed** – Meter at maximum speed (3330 RPM).

### Recommendation

- Decrease vehicle speed.
- Verify that display speed matches actual speed.

**Low Voltage** – Voltage for a SureSpeed has dropped below recommended operation level.

### Recommendation

- Inspect cabling going from the RCM2to the SureSpeed.
- Verify high power going to the RCM. Check for 24V on the 2-pin duetsch connection.
- Inspect power distribution cabling leading back to the generator/power source.

**Light Strength Out of Range Low Voltage**

### Recommendation

- a. Put the system into rate not responding mode with a manual speed of 1mph.
- b. View the Light Strength diagnostic and look for outlier values.
- c. On rows with outlier values inspect the delivery tube for blockages and clean seed tube sensor.



This is a list of common errors messages. For a complete list of error messages and troubleshooting steps please consult a Dealer or our Ag Leader

Knowledgebase: <https://portal.agleader.com/community/s/article/SureSpeed-Alarms-and-Errors>

## Diagnostic Screens

To access the Row or Planter Control Module(s) Diagnostics screen, press:



Technical Support may request that you look at these screens for help in diagnosing a problem. To access the Row or Planter Control Module(s) Diagnostics screen, press. Technical Support may request that you look at these screens for help in diagnosing a problem.

## Row Control Module



Press  to get to Diagnostic tables.

In the CAN-A Devices screen highlight any of the items marked Planter Row Control Module, then press the Diagnostics button. This will display diagnostic values for all rows on the planter. The Row Module Diagnostics screen includes:

The planter diagnostic window allows you to select a specific module on the system and see all diagnostics for that module. Select the icon in the bottom right to switch to a table view.

## Seed Meter



•**RPMs** — Rotational speed of SureSpeed on a specific row. (MAX 140)

•**Voltage** — Current voltage reading of the SureSpeed meter motor

•**Current** – Current reading of the SureSpeed meter motor (Amps)

•**Stalled** — Indicates whether a SureSpeed motor has stalled.



Caution symbol will appear in this column if a drive as stalled. To return a drive to operational state, first inspect and correct the issue that initially stalled the drive. Then cycle the planter to a non-planting state, to a planting state (turning the Master Switch OFF then ON, or raising and lowering the planter to trip the implement switch will accomplish this).

- **Revolutions (x1000)** – Indicates how fast the meter is turning based on population and tractor speed.
- **Hours** – Number of hours that motor/module have been on that rows SureSpeed meter

### Seed Monitoring

Row	Seed Monitor	Seeds/Second	Seeds/Acre	Vacuum Sensor	Vacuum Pressure
1	Enabled	20	31549	Enabled	18.07
2	Enabled	21	32342	Disabled	--
3	Enabled	20	31944	Disabled	--
4	Enabled	20	31601	Disabled	--
5	Enabled	20	32228	Disabled	--
6	Enabled	21	32362	Enabled	17.66
7	Enabled	20	32549	Disabled	--

• **Seed Monitor** – Indicates whether seed monitoring is enabled or disabled for the configuration

• **Seeds/sec** — Provides instantaneous feedback from the matching seed tube sensor. This feedback is not dependent on operating state. This is a useful tool for troubleshooting seed tube sensors or performing pre-season checks to verify sensor operation.

- **Seeds/Acre** – Indicates the populations being planted. This is calculated using Seeds/Second, ground speed, and row spacing.
- **Vacuum Pressure** - shows the vacuum pressure of each row with an installed sensor.

## Delivery Tube

0.00 ac 4.9 mph Variety A sds/ac 4000 0

**Row Module Diagnostics**

Seed Meter	Seed Monitoring	Down Force	Delivery Tube	Power	Seed Sensor	
Row	RPM	Voltage	Current	Stalled	Revolutions (x1000)	Hours
1	0	0.0	0.0		0	0
2	0	0.0	0.0		0	0
3	0	0.0	0.0		0	0
4	0	0.0	0.0		0	0
5	0	0.0	0.0		0	0
6	0	0.0	0.0		0	0
7	0	0.0	0.0		0	0

Planter State  
Implement Switch: Down

View Seed Meter Diagnostics description

## Seed Sensor

0.00 ac 4.9 mph Variety A sds/ac 4000 0

**Row Module Diagnostics**

Seed Meter	Seed Monitoring	Down Force	Delivery Tube	Power	Seed Sensor	
Row	Run Time	Light Strength	Flights/Second	Voltage	LED Brightness	Gain
1	00:13:36	1862 mV	0	11.116 V	3600	3
2	00:13:36	2963 mV	0	11.181 V	2025	3
3	00:13:36	3106 mV	0	11.24 V	1518	3
4	00:13:36	2879 mV	0	11.223 V	1138	3
5	00:13:36	3253 mV	0	11.196 V	2025	3
6	00:13:36	3274 mV	0	11.053 V	2025	3
7	00:13:36	3377 mV	0	11.17 V	2025	3

Planter State  
Implement Switch: Down

- Run Time - Indicated time that the seed tube sensor has been on. This value resets on power cycles.
- Light Strength (VPEAK) – Light Value from detector side. Can be an indication of dust build up.
- Flights/Second – Indicates the number of delivery tube belt flights counted by the seed sensor per second.

- Voltage -Indication current voltage that the seed sensor on a specific row (11-12 volts)
- LED Brightness – Proportional to the voltage drive on the LEDs.
- Gain – Gain applied directly to the measured signal prior to processing.





**NOTE!:** Large outliers in Light Strength or LED Brightness can indicate sensor obstruction or damage.

## Planter Control Module

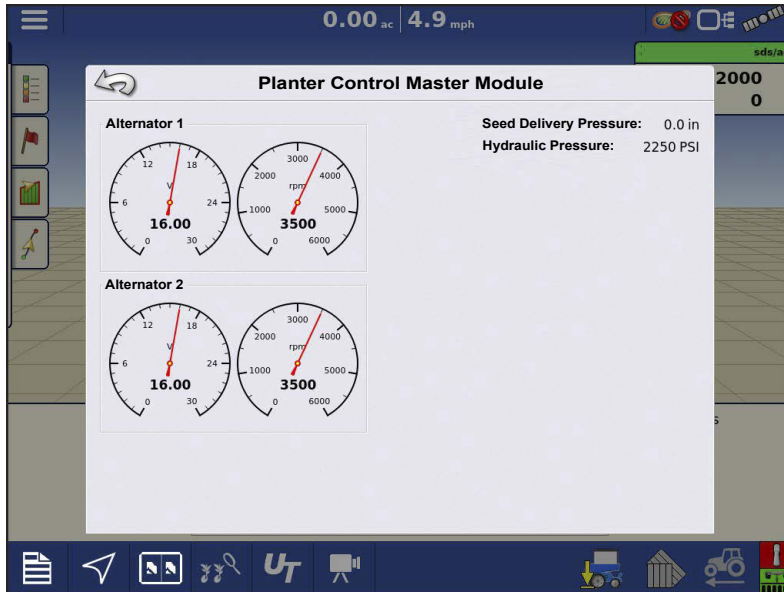

In the CAN-A Devices screen highlight the item marked Planter Control Master Module, then press the Diagnostics button. This will display diagnostic values being input to the Planter Control Master Module. The Planter Control Master Module Diagnostics screen includes:

- **Battery Voltage** — Voltage of battery connected to the alternator. (24v-28v)
- **Alternator Voltage** — Voltage being

generated by the alternator. (24v-28v)

- **Alternator Speed** — Indicates the RPM of the alternator. (3000-4000)
- **Seed Delivery Pressure** — Pressure from bulk fill pressure sensor connected to the Planer Control Module. (This value will be 0 if a bulk fill sensor is not configured)
- **Hydraulic Pressure** — Input pressure from tractor to the hydraulic valve block(s) for Down Force. (This value will be 0 if Hydraulic Down Force is not configured)

## Frequently Asked Questions (FAQ)

What is the max population I can plant at with SureSpeed?

At speeds up to 12 mph, corn can be planted at up to 40,000 sds/ac (30" spacing and 32 cell corn disk) and soybeans can be planted up to 150,000 sds/ac (30" spacing and 92 cell dual row soybeand disk). Higher rates can be achieved at lower ground speeds as well providing the flexibility to plant at the speed and rate that works on your farm.

What are the hydraulic requirements for the generator and hydraulic down force?

---

The SureSpeed systems use a 160-amp 24v generator for power, which requires up to 9 gpm of hydraulic flow. When calculating total hydraulic requirements, be sure to consider requirements of your downforce system (i.e. SureForce requires 0.25 gpm/row)

How many vacuum pressure sensors are supported?

SureSpeed supports one vacuum pressure sensor per row, but will only display three on the run screen. The readings for other rows will be shown in the diagnostics window.

Can the generator circuit breaker be left in the ON position when not in use?

Yes. The circuit breaker can be left in the ON position when the generator is not in use. Leaving circuit breaker ON will not cause any voltage leak from the battery to the SureSpeed system due to a coil disconnect in the alternator. When the generator is not in use for long periods of time, the circuit breaker can be turned OFF as a precautionary measure.

What is the current draw for a single row of SureSpeed and SureForce

SureSpeed requires up to 2.3amps per row and SureForce requires .7 amps per row for a total of 3 amps.

## **SureSpeed Indicator Lights**

### **Planter Control Module 2 (PCM2)**





**Φ Power**

Status	Definition
Off	- No power to the module. Check for CAN power (Red to Black) on the 4 pin cannon connector on the implement harness.
Blinking Yellow	Module is currently upgrading
Solid Yellow	Module is stuck in upgrade mode. Power cycle the module and reflash firmware.
Green	Module has CAN power.

---

## LED 1

Status	Definition
Off	No Local CAN Communication (RCM2 to PCM2). Check CAN High (Yellow to Black) for power (2.5-3v), and check CAN Low (Green to Black) for power (2-2.5v) on the local can bus.
Red	CAN Bus is off.
Yellow	Local CAN Bus error. Check cabling for grounding errors, check terminator for proper resistance (120ohms), and check other modules for proper function.
Green	PCM2 has good communication on the local CAN Bus.

## LED 2

Status	Definition
Off	No Display CAN Communication. Check CAN High (Yellow to Black) for power (2.5-3v), and check CAN Low (Green to Black) for power (2-2.5v) on the CAN implement harness.
Red	CAN Bus is off.
Yellow	Local CAN Bus error. Check cabling for grounding errors, check terminator for proper resistance (120ohms).
Green	PCM2 has good communication on the local CAN Bus.

## Alternator Management Circuit (AMC)

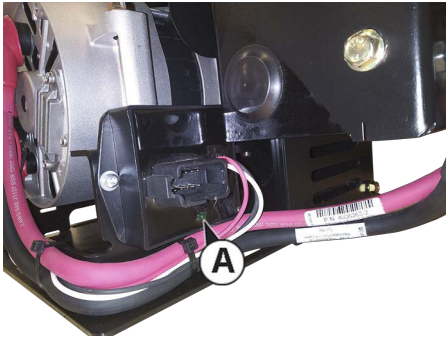

### LED (A)

Status	Definition
Off	Not receiving power. Verify alternator is engaged. If alternator is engaged check generator cabling for alternator power.
Solid Green	Alternator is functioning correctly.

## Row Control Module 2 (RCM2)

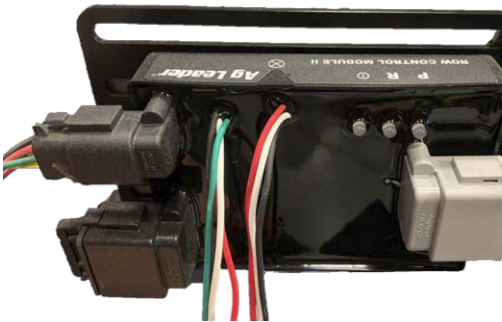

---

## Power $\Phi$

Status	Definition
Off	No CAN power. Check local CAN Bus cabling for 12v CAN power (Red to Black)
Solid Red	No High Current Power. Check 2 pin high current power connector for high current power (24v). If power is not found check high current power fuses.
Blinking Red	Modules are indexing. If indexing does not complete within 30 seconds check for continuity on the blue indexing wire.
Blinking Yellow	Module is upgrading.
Solid Green	Module has 24v high current power.

## LED P

Status	Definition
Off	No Local CAN Communication (RCM2 to PCM2). Check CAN High (Yellow to Black) for power (2.5-3v), and check CAN Low (Green to Black) for power (2-2.5v) on the local can bus.
Red	CAN Bus is off.
Yellow	Local CAN Bus error. Check cabling for grounding errors, check terminator for proper resistance (120ohms), and check other modules for proper function.
Green	RCM2 has good communication to the PCM2 on the local CAN Bus.

**LED R**

Status	Definition
Off	No Local CAN Communication (RCM2 to PCM2). Check CAN High (Yellow to Black) for power (2.5-3v), and check CAN Low (Green to Black) for power (2-2.5v) on the local can bus.
Red	CAN Bus is off
Yellow	No Communication with Motor Drivers. Check cabling to Meter and Delivery System Motors
Green	Good communication with Meter and Delivery System Motors

**Implement Switch Module**



**Left LED**

Status	Definition
Off	No Local CAN Communication (Implement Switch Module to PCM2). Check CAN High (Yellow to Black) for power (2.5-3v), and check CAN Low (Green to Black) for power (2-2.5v) on the local can bus
Red	CAN Bus is off.
Yellow	Local CAN Bus error. Check cabling for grounding errors, check terminator for proper resistance (120ohms), and check other modules for proper function.
Blinking Green	PCM2 has good communication on the local CAN Bus

## Right LED

Status	Definition
Off	Planter Up
Blue	Planter Down

## Seed Tube Sensor



### LED

Status	Definition
Off	No Communication with RCM2. Check cabling
Solid Green	Communicating with RCM2 and does not see seed
Blinking Yellow	Sensor sees seed passing by
Solid Red	Sensor Fault, Replace Sensor
Blinking Red	Sensor Error, Reboot System
Solid Blue	Upgrading Normally

## Meter and Delivery System Motors



### LED (A)

Status	Definition
Off	No Communication with motor driver module. Check cabling
Blinking Green	Motor is communicating with RCM2.
Blinking Red	Motor driver module is corrupt. Call technical support.



## RCM Errors



The message that will appear when all modules have been detected on the CAN bus but there is an indexing issue.



The message that will appear when there are more modules on the CAN bus than what the config requires.

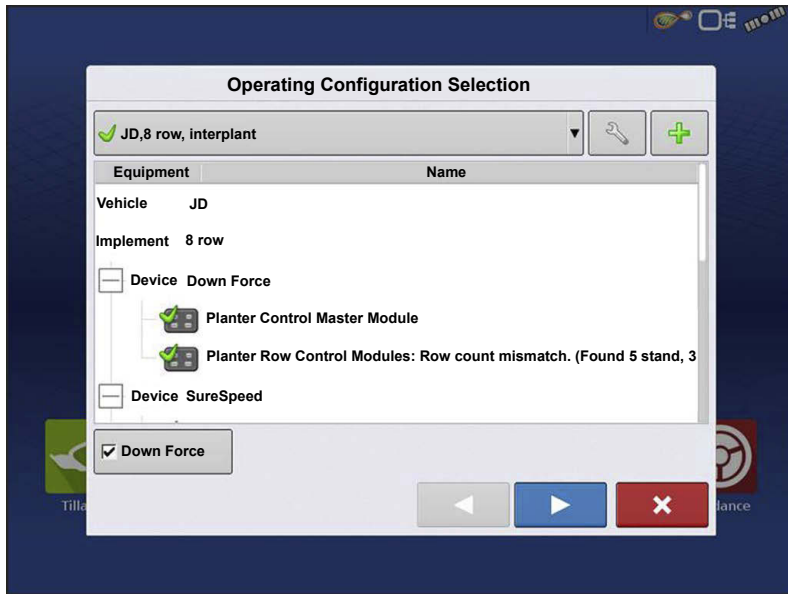

The message that will appear when there is an actual Split Row Mismatch due to a bad jumper in one of the interplant row modules.

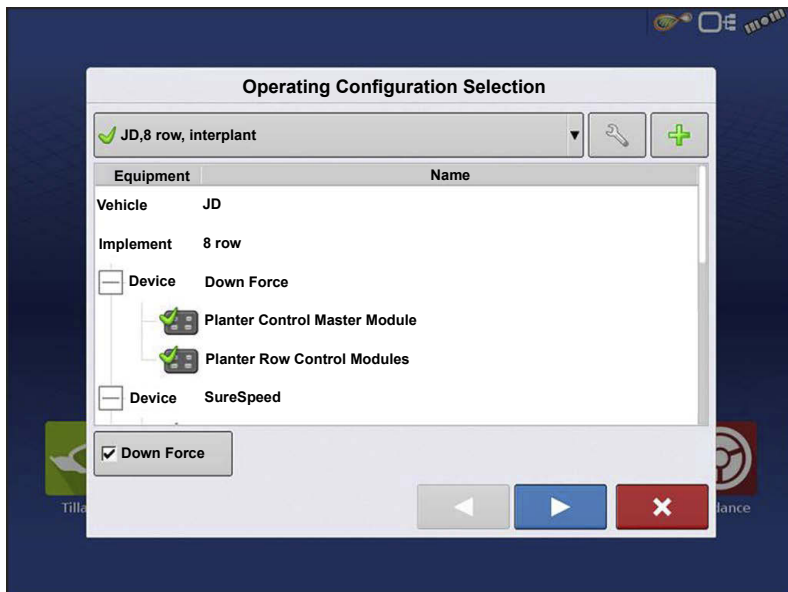

How the Field Select Wizard should appear when all RCM modules have been found on the CAN Bus, properly indexed, and properly assigned to each of the rows.





## Safety and Notices

Read Operators Manual completely before operating display. Understand and follow all operating and safety instructions for proper use of meter system. Failure to use meter system properly could result in an impairment of the safety features of this product.

## Service and Support

For Technical Support contact your local dealer or Ag Leader Support at the number below.

ph: (515) 735-7000

e-mail: support@agleader.com

## System and Upgrades

Required software updates will be available free of charge for download from [www.agleader.com](http://www.agleader.com). It is recommended that the user check for available updates at the beginning of each season.

## Automated Module Firmware Upgrade

Module firmware upgrades are packaged in a single .fw3 file. The module firmware files are stored internally in the display. A warning is shown when a module upgrade is required. All files can be upgraded in a single batch by using an upgrade screen.

## Product Registration

Registering allows the option of receiving notice of any new product updates or features.

Register at the Ag Leader Web site:

<http://www.agleader.com>

## Operator Safety



**DANGER!** Read and understand this manual before using the equipment. It is equally important that other operators of this equipment read and understand this user guide also.

If any portion of this manual remains unclear after reading it, contact dealer for further explanation before using the equipment.



**DANGER!** Keep children away from the equipment.

## Service



**DANGER!** Never service or repair the equipment while it is operating. Always replace all safety devices or shields immediately after servicing.

---

 **DANGER!** Turn electrical power off before connecting and disconnecting the display and transducers, servicing or using a battery charger.

 **DANGER!** If an arc welder is used on the equipment or anything connected to the equipment, disconnect power leads before welding.

 **DANGER!** Do not use a high pressure cleaner to clean the electronic components.

## Special Considerations

### John Deere MaxEmerge™ Plus and MaxEmerge™ 2, White 8000 and 9000 series, row units

Due to the construction of these row units, high speed planting is not recommended. Damage to the row unit can occur due to the increased forces acting on it with increased travel speed. Factors such as high supplemental downforce, no-till farming practices, and others, also increase the forces acting on the row unit especially when in addition to high speed planting. When installing SureSpeed on these row units, use caution to operate at a speed appropriate for your planting conditions and planter setup.

## Operation

### Meter Disassembly

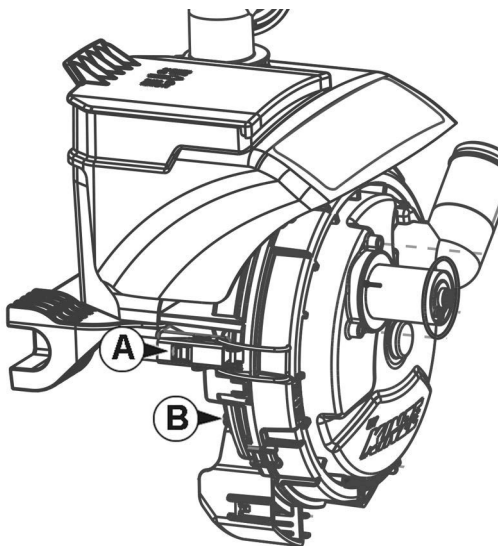

To remove cover, release left and right meter latches (A), press in tab (B) and rotate clockwise.

## Split Row Vacuum Plug

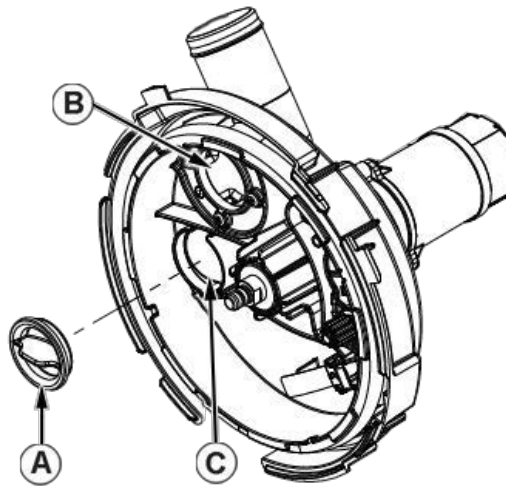

Remove vacuum plug (A) from port opening (B) while planting with split rows. Store the plug in location (C) when planting split rows.

When split rows are not in use plug port (B) with vacuum plug (A). Plugging port reduces vacuum load.

## Seed Disc

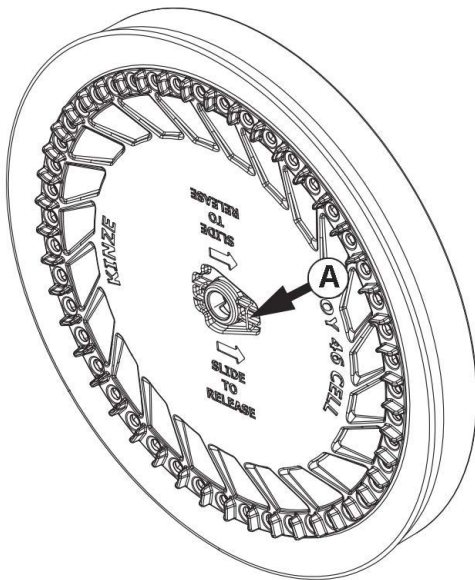

To remove seed disc, push tap of wire clip (A) away from center of disk. Seed disc will lift off of shaft. When installing seed disc, be sure to move wire clip toward shaft to lock disc in place

---

## Ejector

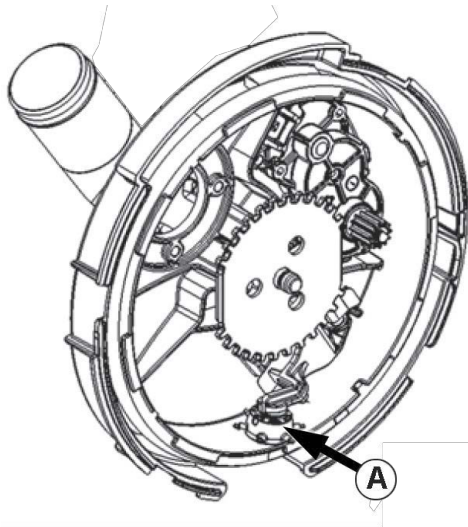

The ejector is held in place on the meter by the ejector arm retention spring.

To remove ejector, raise spring and slide ejector out from under it.

To install ejector, slide ejector under ejector arm retention spring.

### **NOTE!: Wheel-Type Ejectors**

Wheel-type ejectors expel seed and remnants from seed disc cells. These ejectors are disc specific, color-coded to match their corresponding disc, and necessary for proper meter performance.

## Singulator

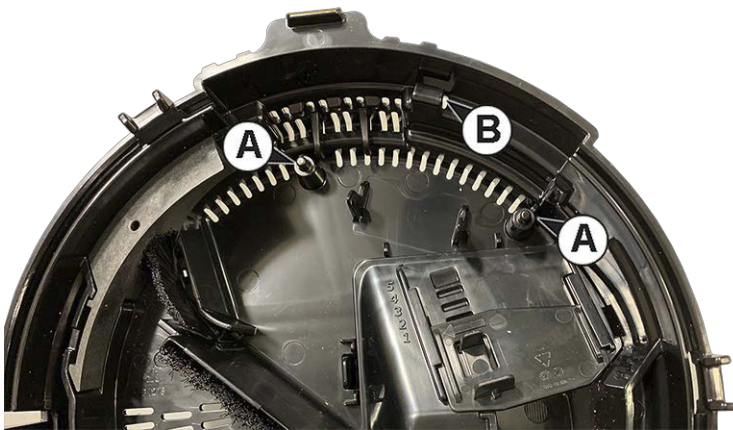

The singulator rests on posts (A) and is held in place by hook (B).

To remove singulator:

Push down on singulator, move away from hook (B), and lift up.

## Installing Singulator



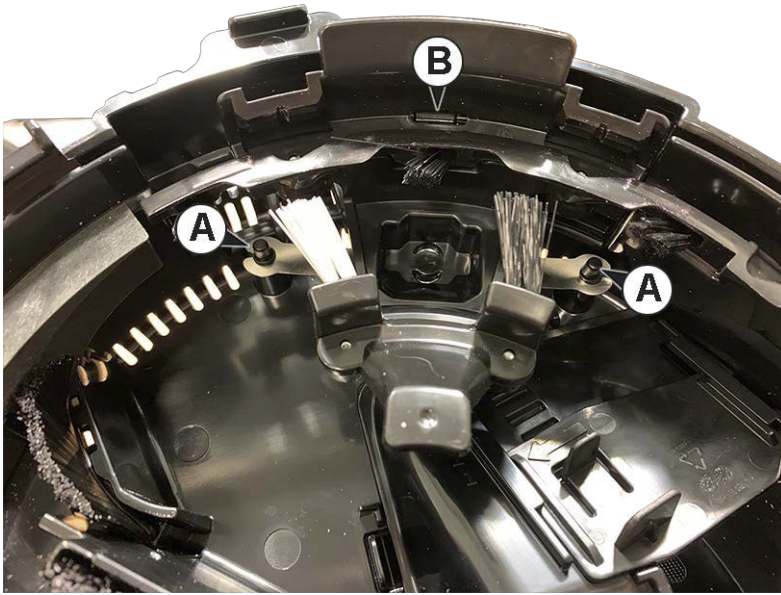

Rest holes in metal clip on posts (A).  
Push down and out on singulator,  
allowing wire clip on back of singulator  
to move around hook (B) and then be  
secured by hook (B).

When installed, singulator with float on  
posts, with metal clip allowing  
movement but maintaining proper  
attachment.

---

## Delivery Tube Disassembly

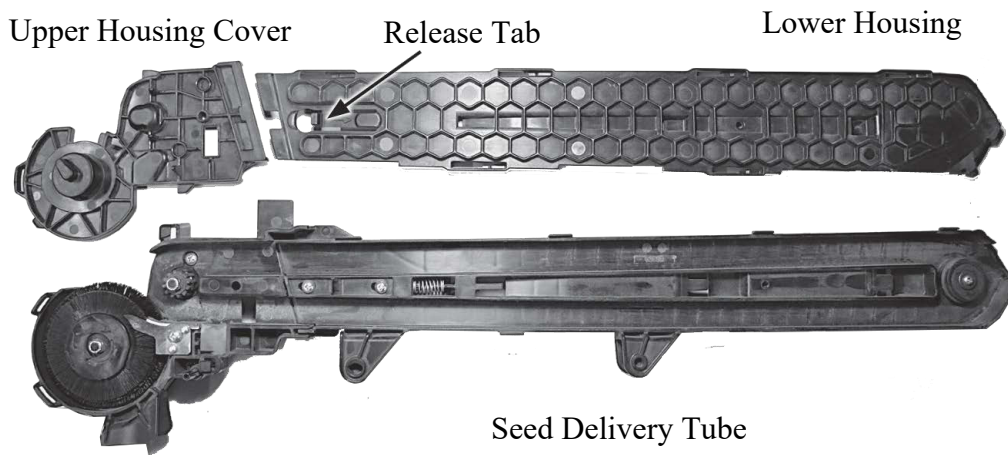

1. Unplug electrical connections and remove delivery tube from row unit.
2. Unscrew and remove seed sensor from delivery tube.
3. Lift release tab and slide lower housing cover downward. Lift and remove.
4. Lift up and slide upper housing cover downward to disengage.

## Delivery Tube Inspection

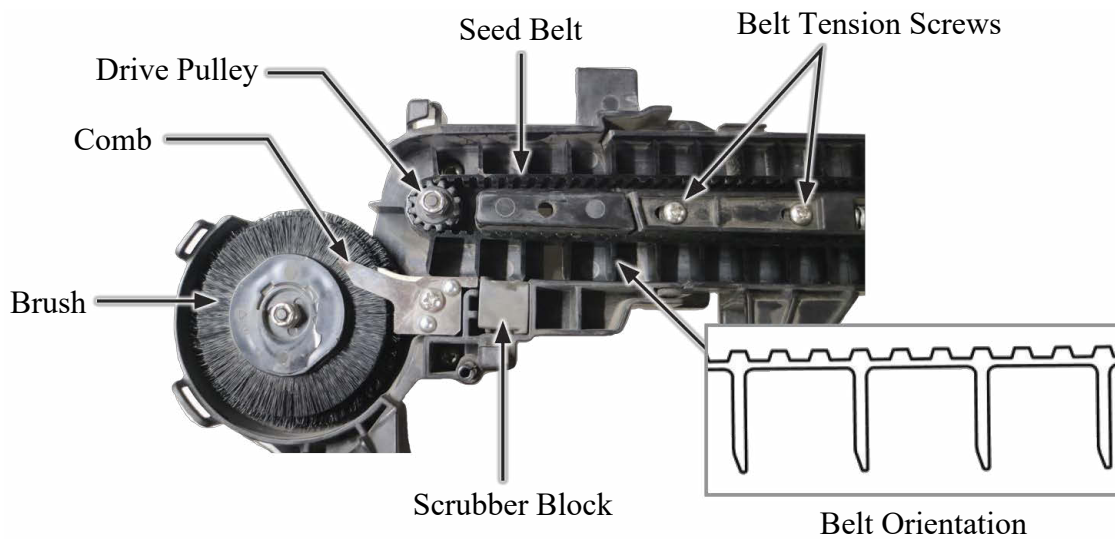

Before every planting season inspect brush wheel, comb, and seed belt. Clean or replace as needed. Turn and reuse other side of scrubber block if one side is worn. Replace if both sides are worn.

## PreSeason Checklist

- Inspect and clean seed discs daily checking for any buildup of foreign material and blocked orifices. If seed disc orifices are plugged frequently with seed remnants, ejector wheel may need to be replaced. Clean seed disc by washing it with soap and water. Dry thoroughly.

See [Meter Disassembly](#) on [page 506](#) for information on how to remove and install seed disc.

See [Inspection Intervals and Wear Characteristics](#) on [page 531](#) for wear indications.

- Replace seed disc or vacuum seal if abnormally high vacuum is required or if consistent operation cannot be achieved.
- Inspect and clean ejector wheel may need to be replaced. See [Inspection Intervals and Wear Characteristics](#) on [page 531](#) for wear indications.
- Inspect singulator. Clean or replace as needed. See [Inspection Intervals and Wear Characteristics](#) on [page 531](#) for wear indications.
- John Deere MaxEmerge™ Plus/2 and Harvest International have 2 roll pins through the front shank and seed tube guard that need to be checked each season.

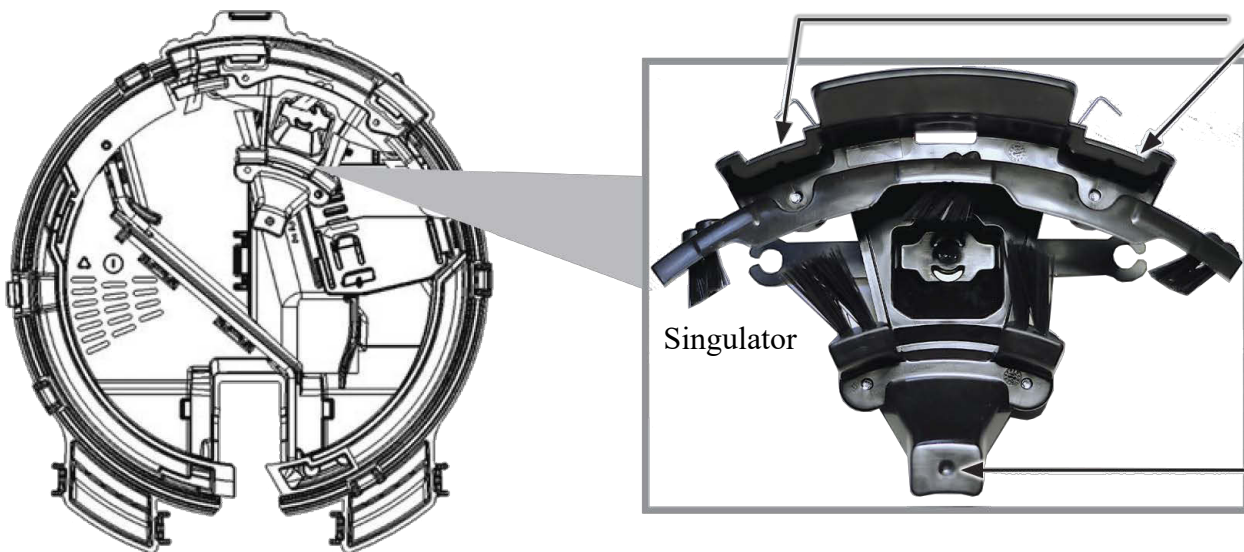

If singulator is not eliminating doubles or if wear markers are not visible, singulator may need to be replaced.

---

## **Belt Tension Adjustment**

Proper belt tension is necessary for long life and optimum performance of seed delivery system. Excessive belt tension can cause increased wear of upper drive pulley and under tensioned belts can cause faulty seed sensor readings.

Belt Tensioning Procedure:

When installing or changing parts, tensioning belt will be necessary.

1. Loosen belt tension screws.
2. Compress and loosen upper and lower halves of delivery tube to verify the two parts moves freely.
3. Manually pull upper and lower half apart and let go so the two halves are held only by tension spring.
4. Tighten belt tension screws.

## **Visual Belt Tension Inspection**

Belt tension can also be checked visually without performing the re-tension process. Manually move belt in the correct direction from the return side of the delivery tube. There should be no contact between tips of belt flights and face of delivery tube comb, ribs on scrubber block, or wall edge before seed sensor window. Under tensioned delivery tube belts will usually drag on these surfaces and can also exhibit outward spring around upper drive pulley.

## Properly Tensioned Belt Characteristics

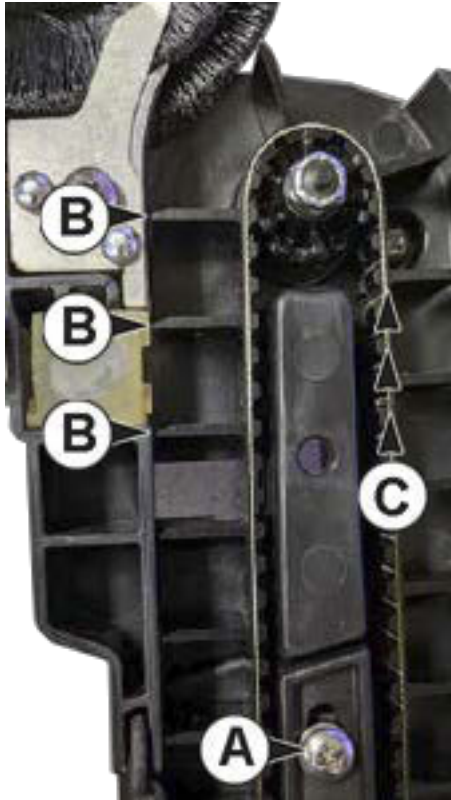

A. Belt Tension Screws Tight

B. No Contact between Belt Flight Tips and Face of Delivery Tube Comb, Scrubber Block, and Edge before Seed Sensor

C. Manually Move Belt

---

## Under Tensioned Belt Characteristics

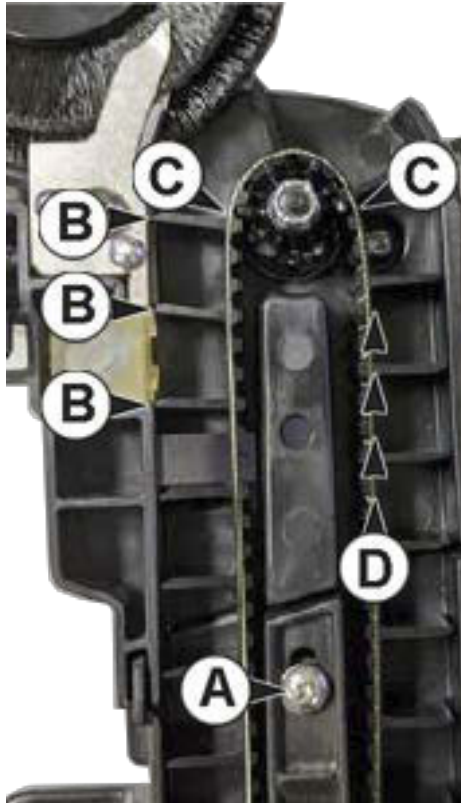

A. Loose Belt Tension Screws





B. Contact between Belt Flight Tips and Face of Delivery Tube  
Comb, Scrubber Block, and Edge before Seed Sensor

C. Spring in belt around upper drive pulley

D. Manually Move Belt

•Use clean, high quality seed for maximum meter accuracy.  
Damaged or cracked seed, hulls, and foreign material may  
become lodged in seed disc orifices and greatly reduce meter  
accuracy.

## Crop Settings

Crop	Seed Disc Kit **	Ejector Wheel (color)	Baffle Setting	Seed Size	Population	Singulator Installed (Yes/No)	Vacuum Setting (InWC)
 Corn 32 Cell (Light Blue)	10892X	1 row 6 punches (Light Blue)	1	1140-2280 seeds/lb (2500 - 5000 seeds/kg)	15-40K seeds/acre (37-100K seeds/hectare)	Yes	*12 to 20 InWC (30 to 50 mbar)
 Soybean 46 Cell (Black)	10894X	1 row 8 punches (Black)	3	2200-4000 seeds/lb (4850-8820 seeds/kg)	All 15" and 20" rows up to 130K seeds/acre (320K seeds/hectare)	No	*15 to 25 InWC (37 to 62 mbar)
 Soybean 92 Cell (Black)	10893X	2 rows 8 punches (Black)	3-5	2200-4000 seeds/lb (2850-8820 seeds/kg)	All 30" rows 20" rows above 130K seeds/acre (320K seeds/hectare)	No	*15 to 20 InWC (37 to 50 mbar)
 Cotton 46 Cell (Green)	10992X	1 row 8 punches (Green)	1	4000-6500 seeds/lb	20k-75k seeds/acre	Yes	*8 to 18 InWC (20 to 45 mbar)
 Sugar Beets/Milo 46 Cell (Orange)	10860X	1 row 8 punches (Orange)	1 use Orange Door	Milo 10000-18000 seeds/lb Sugar Beets Pelletized	20k-100k seeds/acre	Yes	Milo 12 InWC (30 mbar) Sugar Beets 15 InWC (37 mbar)
Sunflower 23 Cell (Yellow)	11124X	1 row 8 punches Yellow	1	Oil #2, 3, 4	12k-35k seeds/acre	Yes	#2: 20 to 30 InWC (50 to 75 mbar) #3 15 to 25 InWC (37 to 62 mbar) #4 10 and 20 InWC (25 to 50 mbar)
*Use low vacuum for small seeds/slow speed and high vacuum for big seeds/high speed							
**Includes all crop specific parts							

Always field check seed population to ensure planting rates are correct.

For best results, use consistent seed size and shape.

Baffle settings are marked 1-5.

Seed treatment, foreign material, dirt or seed chaff may cause gradual reduction of seed disc fill (population).

Excessive seed treatment, humidity, and light-weight seed can affect meter performance. Use ½ cup of talc with each standard hopper fill of seed and mix thoroughly to coat all seeds and adjust rates as needed. Use of talc aids seed flow in meter and singulation.

Foreign material in seed disc orifices, such as seed chips, hulls, or stems, may affect seed delivery. Clean seed ensures accurate seed metering from vacuum seed meter. Remove Seed discs daily to check for buildup of foreign material in seed disc orifices.

See [PreSeason Checklist on page 511](#) for more information.

Damaged seed or seed containing foreign material will cause plugging of seed disc orifices and require more frequent seed meter clean-out to prevent under-planting.

## Recommended Vacuum Levels

### Recommended Vacuum Levels for Corn

#### Meter Speed RPMs (20" Row Spacing 32 Cell Corn Disc)

Ground Speed (mph)

	2	3	4	5	6	7	8	9	10	11	12
24,000	5	8	10	13	15	18	20	23	25	28	30
26,000	5	8	11	14	16	19	22	25	27	30	33
28,000	6	9	12	15	18	21	24	27	29	32	35
30,000	6	9	13	16	19	22	25	28	32	35	38
32,000	7	10	13	17	20	24	27	30	34	37	40
34,000	7	11	14	18	21	25	29	32	36	39	43
36,000	8	11	15	19	23	27	30	34	38	42	45
38,000	8	12	16	20	24	28	32	36	40	44	48
40,000	8	13	17	21	25	29	34	38	42	46	51
42,000	9	13	18	22	27	31	35	40	44	49	53
44,000	9	14	19	23	28	32	37	42	46	51	58
46,000	10	15	19	24	29	34	39	44	48	53	58
48,000	10	15	20	25	30	35	40	45	51	56	61
50,000	11	16	21	26	32	37	42	47	53	58	63

#### Meter Speed RPMs (30" Row Spacing 32 Cell Corn Disc)



		Ground Speed (mph)										
		2	3	4	5	6	7	8	9	10	11	12
Population Setpoint (sds/ac.)	24,000	8	11	15	19	23	27	30	34	38	42	45
	26,000	8	12	16	21	25	29	33	37	41	45	49
	28,000	9	13	18	22	27	31	35	40	44	49	53
	30,000	9	14	19	24	28	33	38	43	47	52	57
	32,000	10	15	20	25	30	35	40	45	51	56	61
	34,000	11	16	21	27	32	38	43	48	54	59	64
	36,000	11	17	23	28	34	40	45	51	57	63	68
	38,000	12	18	24	30	36	42	48	54	60	66	72
	40,000	13	19	25	32	38	44	51	57	63	69	76
	42,000	13	20	27	33	40	46	53	60	66	73	80
	44,000	14	21	28	35	42	49	56	63	69	76	83
46,000	15	22	29	36	44	51	58	65	73	80	87	
48,000	15	23	30	38	45	53	61	68	76	83	91	
50,000	16	24	32	39	47	55	63	71	79	87	95	

- Optimal Zone: 15-76
- Low Meter Speed, may require vacuum adjustment: 5-14
- High Meter Speed, may require vacuum adjustment: 79-95

## Recommended Vac Chart for Corn Flat Seed Types

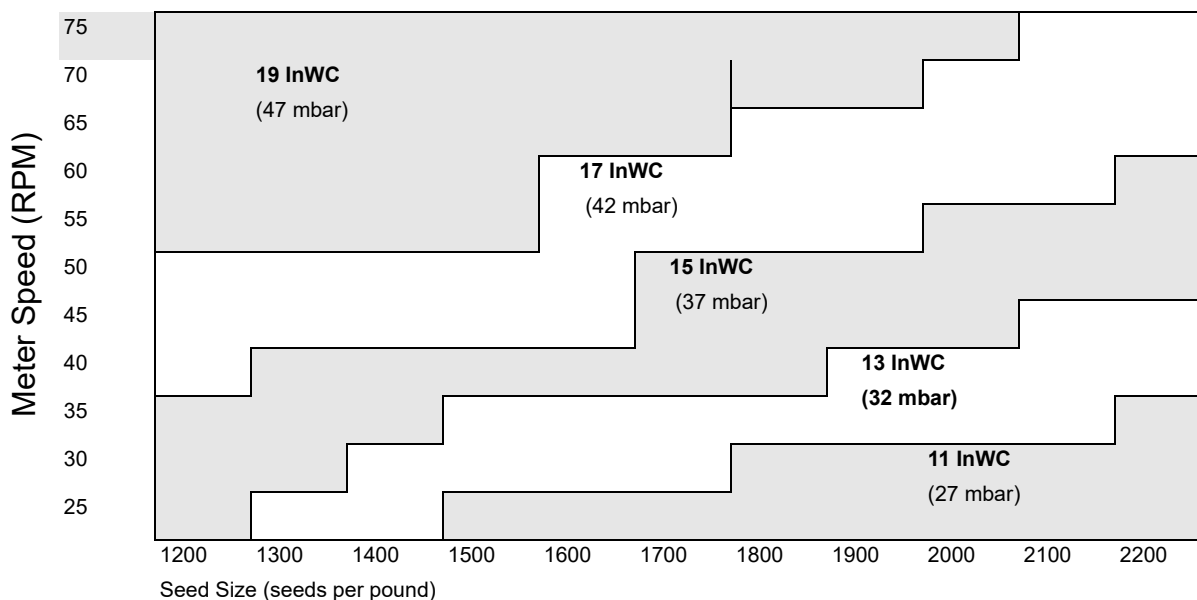

## Recommended Vac Chart for Corn Round Seed Types

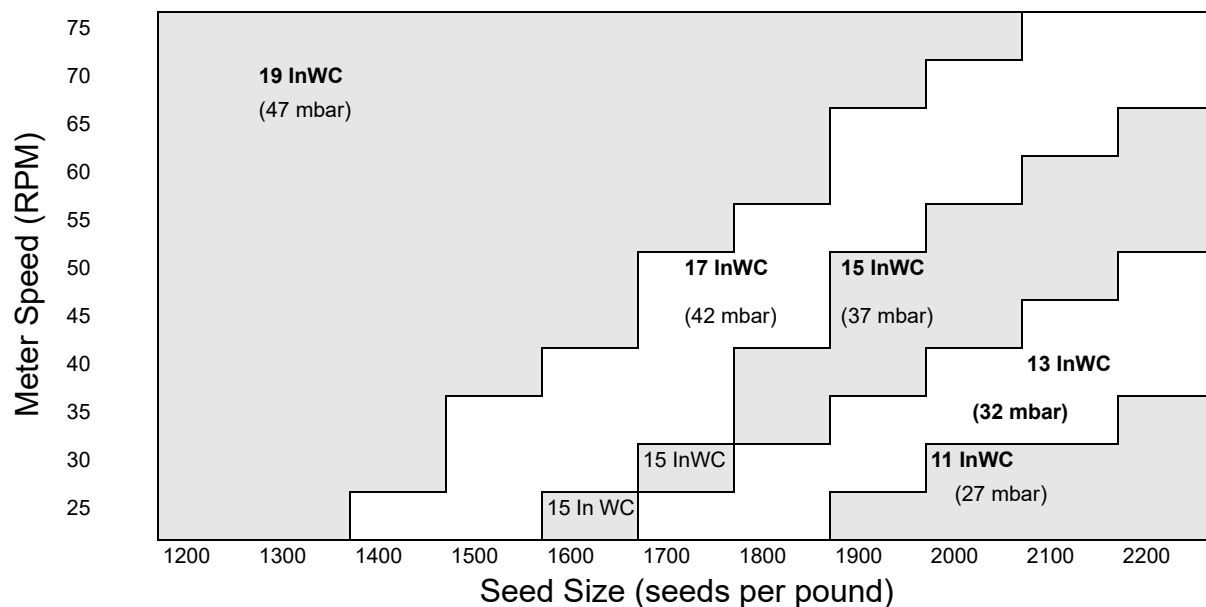

## Recommended Vacuum Level for Soybeans

### Meter Speed RPMs (20" Row Spacing 92 Cell Soybean Disc)

Target Ground Speed (mph)

	2	3	4	5	6	7	8	9	10	11	12
80,000	6	9	12	15	18	20	23	26	29	32	35
85,000	6	9	12	16	19	22	25	28	31	34	37
90,000	7	10	13	16	20	23	26	30	33	36	40
95,000	7	10	14	17	21	24	28	31	35	38	42
100,000	7	11	15	18	22	26	29	33	37	40	44
105,000	8	12	15	19	23	27	31	35	38	42	46
110,000	8	12	16	20	24	28	32	36	40	44	48
115,000	9	13	17	21	25	29	34	38	42	46	51
120,000	9	13	18	22	26	31	35	40	44	48	53
125,000	9	14	18	23	27	32	37	41	46	50	55
130,000	10	14	19	24	29	33	38	43	48	52	57
135,000	10	15	20	25	30	35	40	44	49	54	59
140,000	10	15	20	26	31	36	41	46	51	56	61
145,000	11	16	21	27	32	37	42	48	53	58	64
150,000	11	16	22	27	33	38	44	49	55	60	66
155,000	11	17	23	28	34	40	45	51	57	62	68
160,000	12	18	23	29	35	41	47	53	59	64	70
165,000	12	18	24	30	36	42	48	54	60	66	72
170,000	12	19	25	31	37	44	50	56	62	68	75
175,000	13	19	26	32	38	45	51	58	64	70	77
180,000	13	20	26	33	40	46	53	59	66	72	79

## Meter Speed RPMs

(30" Row Spacing 92 Cell Soybean Disc) or

(15" Row Spacing 46 Cell Soybean Disc)

	Target Ground Speed (mph)										
	2	3	4	5	6	7	8	9	10	11	12
80,000	9	13	18	22	26	31	35	40	44	48	53
85,000	9	14	19	23	28	33	37	42	47	51	56
90,000	10	15	20	25	30	35	40	44	49	54	59
95,000	10	16	21	26	31	37	42	47	52	57	63
100,000	11	16	22	27	33	38	44	49	55	60	66
105,000	12	17	23	29	35	40	46	52	58	63	69
110,000	12	18	24	30	36	42	48	54	60	66	72
115,000	13	19	25	32	38	44	51	57	63	69	76
120,000	13	20	26	33	40	46	53	59	66	72	79
125,000	14	21	27	34	41	48	55	62	69	75	82
130,000	14	21	29	36	43	50	57	64	71	79	86
135,000	15	22	30	37	44	52	59	67	74	82	89
140,000	15	23	31	38	46	54	61	69	77	85	92
145,000	16	24	32	40	48	56	64	72	80	88	96
150,000	16	25	33	41	49	58	66	74	82	91	99
155,000	17	26	34	43	51	60	68	77	85	94	102
160,000	18	26	35	44	53	61	70	79	88	97	105
165,000	18	27	36	45	54	63	72	82	91	100	109
170,000	19	28	37	47	56	65	75	84	93	103	112
175,000	19	29	38	48	58	67	77	86	96	106	115
180,000	20	30	40	49	59	69	79	89	99	109	119

Target Population (sds/ac.)

- Optimal Zone: 21-90
- Low Meter Speed, may require vacuum adjustment: 6-20
- High Meter Speed, may require vacuum adjustment: 91-119

---

## Recommended Vac Chart for Soybeans (Single Row and Dual Row)

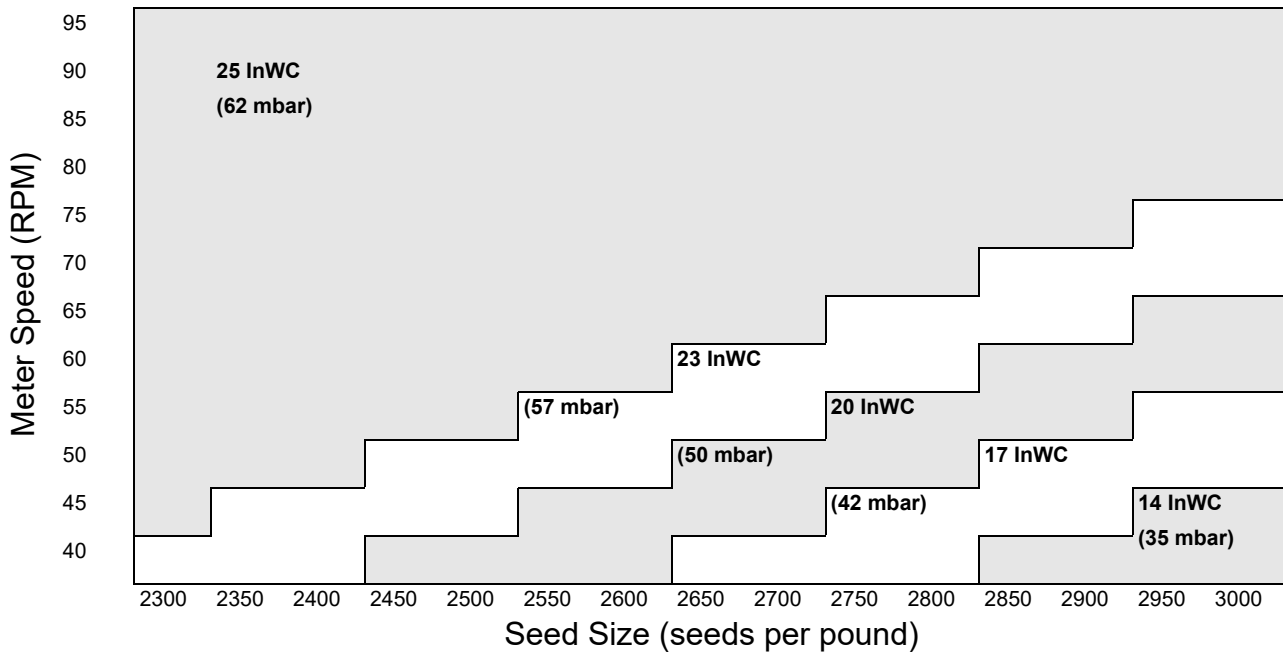

## Recommended Vacuum Level for Soybean, Cotton, Sugar beet/Milo

### Meter Speed RPMs (15" Row Spacing 46 Cell Disc)

		Target Ground Speed (mph)										
		2	3	4	5	6	7	8	9	10	11	12
Target Population (sds/ac.)	20,000	2	3	4	5	7	8	9	10	11	12	13
	25,000	3	4	5	7	8	10	11	12	14	15	16
	30,000	3	5	7	8	10	12	13	15	16	18	20
	35,000	4	6	8	10	12	13	15	17	19	21	23
	40,000	4	7	9	11	13	15	18	20	22	24	26
	45,000	5	7	10	12	15	17	20	22	25	27	30
	50,000	5	8	11	14	16	19	22	25	27	30	33
	55,000	6	9	12	15	18	21	24	27	30	33	36
	60,000	7	10	13	16	20	23	26	30	33	36	40
	65,000	7	11	14	18	21	25	29	32	36	39	43
	70,000	8	12	15	19	23	27	31	35	38	42	46
	75,000	8	12	16	21	25	29	33	37	41	45	49
	80,000	9	13	18	22	26	31	35	40	44	48	53
	85,000	9	14	19	23	28	33	37	42	47	51	56
	90,000	10	15	20	25	30	35	40	44	49	54	59
	95,000	10	16	21	26	31	37	42	47	52	57	63
	100,000	11	16	22	27	33	38	44	49	55	60	66
	105,000	12	17	23	29	35	40	46	52	58	63	69
	110,000	12	18	24	30	36	42	48	54	60	66	72
	115,000	13	19	25	32	38	44	51	57	63	69	76
120,000	13	20	26	33	40	46	53	59	66	72	79	
125,000	14	21	27	34	41	48	55	62	69	75	82	
130,000	14	21	29	36	43	50	57	64	71	79	86	
135,000	15	22	30	37	44	52	59	67	74	82	89	
140,000	15	23	31	38	46	54	61	69	77	85	92	
145,000	16	24	32	40	48	56	64	72	80	88	96	
150,000	16	25	33	41	49	58	66	74	82	91	99	
155,000	17	26	34	43	51	60	68	77	85	94	102	
160,000	18	26	35	44	53	61	70	79	88	97	105	
165,000	18	27	36	45	54	63	72	82	91	100	109	
170,000	19	28	37	47	56	65	75	84	93	103	112	
175,000	19	29	38	48	58	67	77	86	96	106	115	
180,000	20	30	40	49	59	69	79	89	99	109	119	

**Meter Speed RPMs - 20" Row Spacing 46 Cell Soybean, Cotton, Sugar beet/Milo Disc**

		Target Ground Speed (mph)										
		2	3	4	5	6	7	8	9	10	11	12
Target Population (sds/ac.)	20,000	3	4	6	7	9	10	12	13	15	16	18
	25,000	4	5	7	9	11	13	15	16	18	20	22
	30,000	4	7	9	11	13	15	18	20	22	24	26
	35,000	5	8	10	13	15	18	20	23	26	28	31
	40,000	6	9	12	15	18	20	23	26	29	32	35
	45,000	7	10	13	16	20	23	26	30	33	36	40
	50,000	7	11	15	18	22	26	29	33	37	40	44
	55,000	8	12	16	20	24	28	32	36	40	44	48
	60,000	9	13	18	22	26	31	35	40	44	48	53
	65,000	10	14	19	24	29	33	38	43	48	52	57
	70,000	10	15	20	26	31	36	41	46	51	56	61
	75,000	11	16	22	27	33	38	44	49	55	60	68
	80,000	12	18	23	29	35	41	47	53	59	64	70
	85,000	13	19	25	31	37	44	50	56	62	68	75
	90,000	14	20	26	33	40	46	53	59	66	72	79
	95,000	15	21	28	35	42	49	56	63	70	76	83
	100,000	15	22	29	37	44	51	59	66	73	81	88
	105,000	15	23	31	38	46	54	61	69	77	85	92
	110,000	16	24	32	40	48	56	64	72	81	89	97
	115,000	17	25	34	42	51	59	67	76	84	93	101
120,000	18	26	35	44	53	61	70	79	88	97	105	
125,000	18	27	37	46	55	64	73	82	91	101	110	
130,000	19	29	38	48	57	67	76	86	95	105	114	
135,000	20	30	40	49	59	69	79	89	99	109	119	
140,000	20	31	41	51	61	72	82	92	102	113	120	
145,000	21	32	42	53	64	74	85	96	106	117	120	
150,000	22	33	44	55	66	77	88	99	110	120	120	
155,000	23	34	45	57	68	79	91	102	113	120	120	
160,000	23	35	47	59	70	82	94	105	117	120	120	
165,000	24	36	48	60	72	85	97	109	120	120	120	
170,000	25	37	50	62	75	87	100	112	120	120	120	
175,000	26	38	51	64	77	90	102	115	120	120	120	
180,000	26	40	53	66	79	92	105	119	120	120	120	

## Meter Speed RPMs (22” Row Spacing 46 Cell Soybean, Cotton, Sugar beet/Milo Disc)

		Target Ground Speed (mph)										
		2	3	4	5	6	7	8	9	10	11	12
Target Population (sds/ac.)	20,000	3	5	6	8	10	11	13	14	16	18	19
	25,000	4	6	8	10	12	14	16	18	20	22	24
	30,000	5	7	10	12	14	17	19	22	24	27	29
	35,000	6	8	11	14	17	20	23	25	28	31	34
	40,000	6	10	13	16	19	23	26	29	32	35	39
	45,000	7	11	14	18	22	25	29	33	36	40	43
	50,000	8	12	16	20	24	28	32	36	40	44	48
	55,000	9	13	18	22	27	31	35	40	44	49	53
	60,000	10	14	19	24	29	34	39	43	48	53	58
	65,000	10	16	21	26	31	37	42	47	52	58	63
	70,000	11	17	23	28	34	39	45	51	56	62	68
	75,000	12	18	24	30	36	42	48	54	60	66	72
	80,000	13	19	26	32	39	45	52	58	64	71	77
	85,000	14	21	27	34	41	48	55	62	68	75	82
	90,000	14	22	29	36	43	51	58	65	72	80	87
	95,000	15	23	31	38	46	54	61	69	76	84	92
	100,000	16	24	32	40	48	56	64	72	81	89	97
	105,000	17	25	34	42	51	59	68	76	85	93	101
	110,000	18	27	35	44	53	62	71	80	89	97	106
	115,000	19	28	37	46	56	65	74	83	93	102	111
120,000	19	29	39	48	58	68	77	87	97	106	116	
125,000	20	30	40	50	60	70	81	91	101	111	120	
130,000	21	31	42	52	63	73	84	94	105	115	120	
135,000	22	33	43	54	65	76	87	98	109	120	120	
140,000	23	34	45	56	68	79	90	101	113	120	120	
145,000	23	35	47	58	70	82	93	105	117	120	120	
150,000	24	36	48	60	72	85	97	109	120	120	120	
155,000	25	37	50	62	75	87	100	112	120	120	120	
160,000	26	39	52	64	77	90	103	116	120	120	120	
165,000	27	40	53	66	80	93	106	120	120	120	120	
170,000	27	41	55	68	82	96	110	120	120	120	120	
175,000	28	42	56	70	85	99	113	120	120	120	120	
180,000	29	43	58	72	87	101	116	120	120	120	120	

**Meter Speed RPMs (30” Row Spacing 46 Cell Soybean, Cotton, Sugar beet/Milo Disc)**

		Target Ground Speed (mph)										
		2	3	4	5	6	7	8	9	10	11	12
Target Population (sds/ac.)	20,000	4	7	9	11	13	15	18	20	22	24	26
	25,000	5	8	11	14	16	19	22	25	27	30	33
	30,000	7	10	13	16	20	23	26	30	33	36	40
	35,000	8	12	15	19	23	27	31	35	38	42	46
	40,000	9	13	18	22	26	31	35	40	44	48	53
	45,000	10	15	20	25	30	35	40	44	49	54	59
	50,000	11	16	22	27	33	38	44	49	55	60	66
	55,000	12	18	24	30	36	42	48	54	60	66	72
	60,000	13	20	26	33	40	46	53	59	66	72	79
	65,000	14	21	29	36	43	50	57	64	71	79	86
	70,000	15	23	31	38	46	54	61	69	77	85	92
	75,000	16	25	33	41	49	58	66	74	82	91	99
	80,000	18	26	35	44	53	61	70	79	88	97	105
	85,000	19	28	37	47	56	65	75	84	93	103	112
	90,000	20	30	40	49	59	69	79	89	99	109	119
	95,000	21	31	42	52	63	73	83	94	104	115	120
	100,000	22	33	44	55	66	77	88	99	110	120	120
	105,000	23	35	46	58	69	81	92	104	115	120	120
	110,000	24	36	48	60	72	85	97	109	120	120	120
	115,000	25	38	51	63	76	88	101	114	120	120	120
120,000	26	40	53	66	79	92	105	119	120	120	120	
125,000	27	41	55	69	82	96	110	120	120	120	120	
130,000	29	43	57	71	86	100	114	120	120	120	120	
135,000	30	44	59	74	89	104	119	120	120	120	120	
140,000	31	46	61	77	92	108	120	120	120	120	120	
145,000	32	48	64	80	96	111	120	120	120	120	120	
150,000	33	49	66	82	99	115	120	120	120	120	120	
155,000	34	51	68	85	102	119	120	120	120	120	120	
160,000	35	53	70	88	105	120	120	120	120	120	120	
165,000	36	54	72	91	109	120	120	120	120	120	120	
170,000	37	56	75	93	112	120	120	120	120	120	120	
175,000	38	58	77	96	115	120	120	120	120	120	120	
180,000	40	59	79	99	119	120	120	120	120	120	120	



## Meter Speed RPMs (36" Row Spacing 46 Cell Soybean, Cotton, Sugarbeet/Milo Disc)

	Target Ground Speed (mph)										
	2	3	4	5	6	7	8	9	10	11	12
20,000	5	8	11	13	16	18	21	24	26	29	32
25,000	7	10	13	16	20	23	26	30	33	36	40
30,000	8	12	16	20	24	28	32	36	40	43	47
35,000	9	14	18	23	28	32	37	42	46	51	55
40,000	11	16	21	26	32	37	42	47	53	58	63
45,000	12	18	24	30	36	42	47	53	59	65	71
50,000	13	20	26	33	40	46	53	59	66	72	79
55,000	14	22	29	36	43	51	58	65	72	80	87
60,000	16	24	32	40	47	55	63	71	79	87	95
65,000	17	26	34	43	51	60	69	77	86	94	103
70,000	18	28	37	46	55	65	74	83	92	101	111
75,000	20	30	40	49	59	69	79	89	99	109	119
80,000	21	32	42	53	63	74	84	95	105	116	120
85,000	22	34	45	56	67	78	90	101	112	120	120
90,000	24	36	47	59	71	83	95	107	119	120	120
95,000	25	38	50	63	75	88	100	113	120	120	120
100,000	26	40	53	66	79	92	105	119	120	120	120
105,000	28	42	55	69	83	97	111	120	120	120	120
110,000	29	43	58	72	87	101	116	120	120	120	120
115,000	30	45	61	76	91	106	120	120	120	120	120
120,000	32	47	63	79	95	111	120	120	120	120	120
125,000	33	49	66	82	99	115	120	120	120	120	120
130,000	34	51	69	86	103	120	120	120	120	120	120
135,000	36	53	71	89	107	120	120	120	120	120	120
140,000	37	55	74	92	111	120	120	120	120	120	120
145,000	38	57	76	96	115	120	120	120	120	120	120
150,000	40	59	79	99	119	120	120	120	120	120	120
155,000	41	61	82	102	120	120	120	120	120	120	120
160,000	42	63	84	105	120	120	120	120	120	120	120
165,000	43	65	87	109	120	120	120	120	120	120	120
170,000	45	67	90	112	120	120	120	120	120	120	120
175,000	46	69	92	115	120	120	120	120	120	120	120
180,000	47	71	95	119	120	120	120	120	120	120	120

Optimal Zone: 15-89

Low Meter Speed, may require vacuum adjustment: 3-14

High Meter Speed, may require vacuum adjustment: 90-119

Exceeding Maximum Meter Speed, expect performance degradation: above 120

**Recommended Vac Chart for Soybean, Cotton, Sugarbeet/Milo**

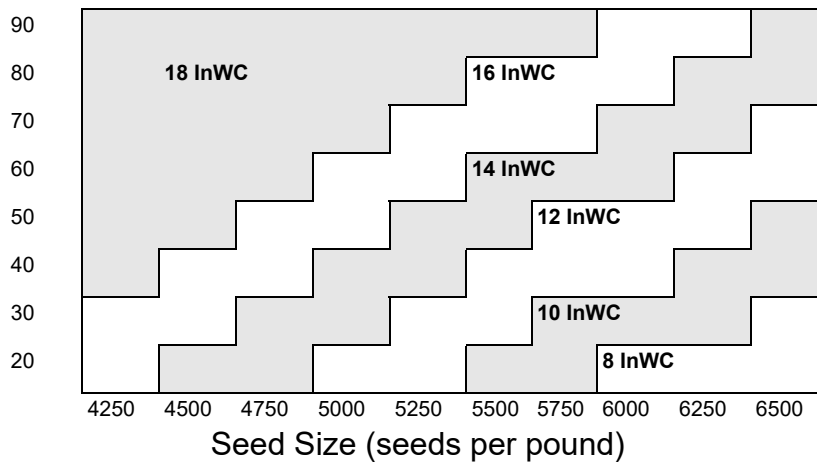

**Meter Speed RPMs (30" Row Spacing 23 Cell Sunflower Disc)**

		Target Ground Speed (mph)										
		2	3	4	5	6	7	8	9	10	11	12
Target Population (sds/ac.)	16,000	7	10	14	18	21	25	28	32	35	39	42
	18,000	8	12	16	20	24	28	32	36	39	43	47
	20,000	9	13	18	22	26	31	35	39	44	48	53
	22,000	10	14	19	24	29	34	39	43	48	53	58
	24,000	11	16	21	26	32	37	42	47	53	58	63
	26,000	11	17	23	28	34	40	46	51	57	63	68
	28,000	12	18	24	31	37	43	50	55	61	68	74
	30,000	13	20	26	33	39	46	53	59	66	72	79
	32,000	14	21	28	35	42	49	56	63	70	77	84
	34,000	15	22	30	37	45	52	60	67	75	82	90
36,000	16	24	32	39	47	55	63	71	79	87	95	

Center of chart shows optimal meter speed zone.

Low or high meter speed, may require vacuum adjustment.

Exceeding maximum meter speed, expect performance degradation

## Recommended Vac Chart for Oil Sunflowers

65	30	30	30	30	30	25	22	16	14	12	12
60	30	30	30	30	30	25	22	16	14	12	12
55	30	30	30	30	25	25	22	16	14	12	12
50	30	30	30	30	25	22	16	14	14	12	12
45	30	30	30	25	25	22	16	14	12	12	12
40	30	30	25	25	22	16	14	12	12	12	10
35	30	25	25	22	20	16	14	12	12	10	10
30	25	25	22	22	20	14	12	12	10	10	8
25	25	22	22	20	16	14	12	10	10	8	8
20	22	22	20	18	16	12	10	10	8	8	8
15	20	20	18	16	14	12	10	8	8	8	8
	5000	5500	6000	6500	7000	7500	8000	8500	9000	9500	1000

Seed Size (seeds per pound)

## Meter Tuning and Adjustments

1. Select seed disc to match crop and population. See [Seed Disc Kit on page 515](#).

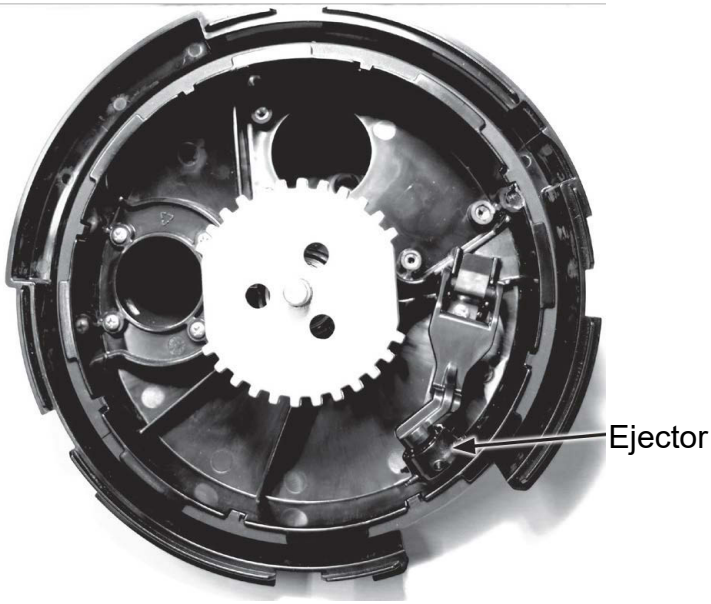

2. Install ejector that corresponds with disc chosen in Step 1. Ejectors are disc specific and color-coded to match their corresponding disc. [See Ejector Wheel on page 515.](#)

Wheel-type ejectors expel seed remnants from seed disc orifices.

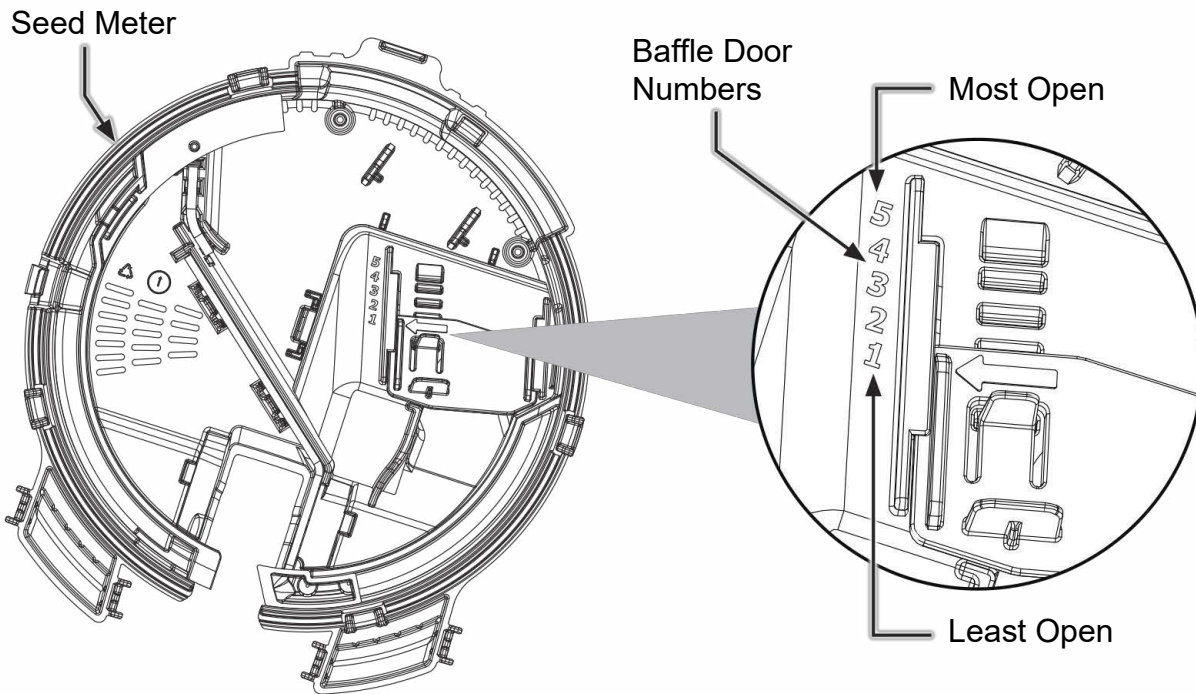

3. Adjust baffle door. See [Baffle Setting on page 515.](#)

The baffle door controls the size of the seed pool in the meter. The seed pool makes seeds available to the seed disc. The higher the number that the baffle is set to, the larger the seed pool.

- If the seed pool is too large, it increases chances of doubles.
  - If the seed pool is too small, it increases the chances of skips.
4. Install meter cover and attach vacuum and seed supply hoses.
  5. With vacuum fan running, use priming sequence to load seed onto seed discs.
  6. Adjust vacuum level. See [Vacuum Setting on page 515](#).
    - Vacuum reading will be much lower when seed disc cells are empty. Prime the seed meter before setting vacuum level.
    - Operate vacuum fan 3-5 minutes to bring oil up to normal operating temperature prior to making final vacuum level adjustment.

## Additives

### Lubricant - Recommended Application Rate

80/20 Talc-Graphite (Recommended)

Bulk Fill Hopper	4 Pounds per 50 Unit Fill
1.7 Bushel Box Hopper	1/2 Cup per Hopper
3 Bushel Box Hopper	1 Cup per Hopper

Must be evenly mixed during fill.

80/20 Talc-graphite is the recommended lubricant for the SureSpeed meter. If flow issues occur, additional graphite or talc may need to be added. Descriptions of the various lubricants, below, can be used as a reference.

Bayer Fluency Agent is only required to be used in place of graphite or talc lubricants on vacuum equipped planters that are sowing neonicotinoid related seeds in Canada. Refer to the Bayer Fluency Agent section for more information.

### 80/20 Talc Graphite (Recommended)

Talc-graphite is used for treated seed, providing benefits of both talc and graphite. It absorbs moisture to prevent bridging, minimize static electricity for improved seed flow, and lubricates seed and meters.

- Regular graphite use prolongs life of the seed meter components, improves seed spacing, and may reduce build-up of seed treatments.
- Talc-Graphite lubricant **MUST** be mixed evenly during fill.

## Graphite

---

Graphite is used to promote seed flow, provide lubrication for the seed meter, and to help dissipate static charge build-up. Graphite is effective, easy to use, and requires no mechanical agitation.

- Regular graphite use prolongs life of the seed meter components, improves seed spacing, and may reduce build-up of seed treatments.
- Additional graphite may be required to retard build-up of seed treatments on meter components. More frequent cleaning of monitor seed tubes may be necessary due to use of additional graphite.

### **Talc**



Talc is used as a drying agent in addition to graphite lubrication. The drying agent may improve seed release and/or retard buildup of seed treatments on meter components.

- Adjust rate of talc use as needed so all seeds are coated, while avoiding a buildup of talc in bottom of hopper.
- Humid conditions and/or small sized seeds with extra seed treatment may require additional talc to maintain meter performance.
- Liquid seed treatments or inoculants may create build-up on the seed disc or brushes. Check frequently for proper population and/or seed delivery when using any liquid seed treatment.
- Completely mix all treatments with seed following manufacturer's recommendations. Seed treatment dumped on top of seed after hopper is filled may not mix properly and cause seed bridging, reducing population or stopping meter from planting.

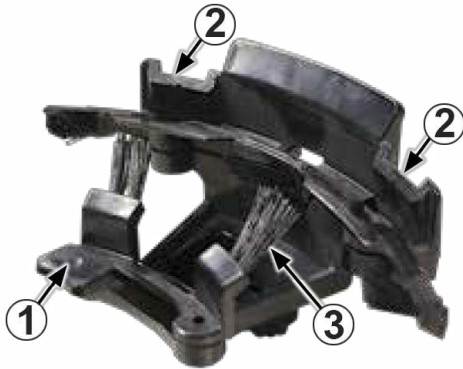
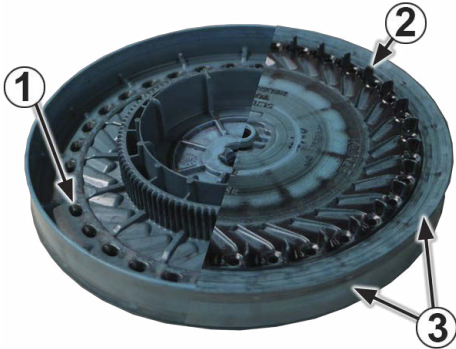

### **Bayer Fluency Agent**

Bayer Fluency Agent is an alternate seed lubricant by Bayer Crop Science. This product replaces graphite and talc to lower the amount of dust from planter vacuum fans. Please follow Bayer Fluency Agent instructions for rates and mixing directions. Follow government regulations to determine if it is required in your area.



## Maintenance

Inspection Intervals and Wear Characteristics				
COMPONENT	INSPECT	REPLACE	WEAR CHARACTERISTICS	
Singulator	Annually	Every 500 row acres or as needed		<ol style="list-style-type: none"> <li>1. Reduced volume on wear indicator.</li> <li>2. Reduced depth in wear indicator.</li> <li>3. Reduced brush pack stiffness.</li> <li>4. Frayed bristles or having a permanent set.</li> </ol>
Seed Disc	Annually	Every 1000 row acres or as needed		<ol style="list-style-type: none"> <li>1. Prominent wear on seed orifice edges.</li> <li>2. Deformed /damaged seed paddles.</li> <li>3. Pronounced ridges.</li> </ol>
Ejector Wheel	Annually	Every 500 row acres or as needed		<ol style="list-style-type: none"> <li>1. Deformed /damaged ejector wheel arms.</li> <li>2. Worn ejector pins.</li> </ol>

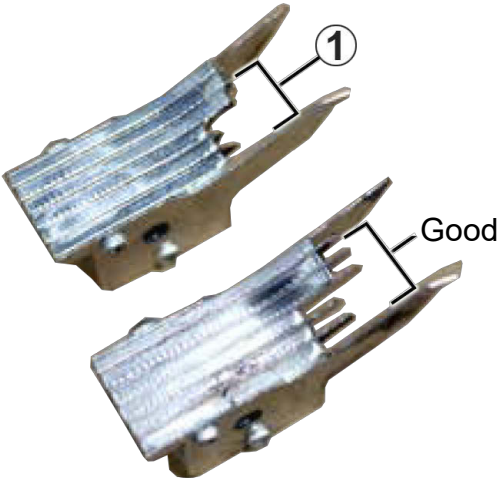
## Inspection Intervals and Wear Characteristics

COMPONENT	INSPECT	REPLACE	WEAR CHARACTERISTICS	
Meter Drive Gear	Annually	Every 2000 row acres or as needed		<ol style="list-style-type: none"> <li>1. Deformed /damaged gear teeth.</li> <li>2. Loose shaft bearings.</li> </ol>
Brush Wheel	Annually	Every 500 row acres or as needed		<ol style="list-style-type: none"> <li>1. Frayed, bent, or broken brush wheel bristles.</li> <li>2. Missing brush filament.</li> <li>3. Exposed filament retention wire.</li> </ol>
Delivery Tube Gearbox	Annually	As needed		<ol style="list-style-type: none"> <li>1. Loose bearings.</li> </ol>
Comb	Annually	Every 500 row acres or as needed		<ol style="list-style-type: none"> <li>1. Reduced comb tip length.</li> </ol>

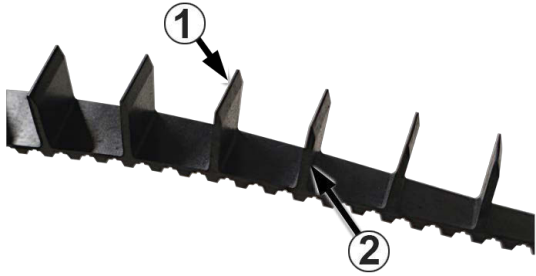

Inspection Intervals and Wear Characteristics				
COMPONENT	INSPECT	REPLACE	WEAR CHARACTERISTICS	
Scrubber Block	Annually	Every 500 row acres or as needed		1. Reduced volume on both sides of block. Replace when ribs are less than 0.025 inches tall.
Seed Belt	Annually	Every 1500 row acres or as needed		1. Deformed /damaged flight tips. 2. Bent flights.
Seed Tube Guard	Every 200 row acres	Every 500 row acres or as needed		Noticeable wear on both sides of guard pads. Replace when seed tube guard pads are less than 1/16" thick or worn down to the level of the surrounding metal.

## End of Season Care

Thorough seed meter cleanout is important to maintain genetic purity.

- Remove bulkfill and vacuum hoses.
- Unplug electrical connections.
- Remove meters and seed delivery tubes.

It is recommended to store meters and delivery tube assemblies in a separate location during off-season to prevent damage.

**Important!:** Make sure brush wheel and bristles of the singulator are not bent during storage.

- 
- Remove seed discs from meters for annual storage and store them in seed disc storage box (PN 4006545)

Discs can also be stored vertically on a dowel or pipe.

- Remove hopper and dump seed into a container.
- For Bulk-Fill Planters: Inspect mini-hopper door for any remaining seed.
- Install vacuum cover.
- Store planter in a dry sheltered area if possible.
- Inspect planter for parts that are in need of replacement and order during the offseason. Make sure all seed and granular chemical hoppers are empty and clean.
- John Deere MaxEmerge™ Plus/2 and Harvest International have 2 roll pins through the front shank and seed tube guard that need to be checked at the end of each season.
- Follow End of Season recommendations from planter manufacturer.
  - Inspect parallel arm bushings, and replace if excessive slop is seen.
  - Inspect closing discs, and replace if diameter is 14.5" or smaller.
  - Serrated Discs are NOT supported with SureSpeed.

## Seed Belt Tension Adjustment

1. Loosen tension screws.
2. Move lower portion of tube up and down to verify that it moves freely.
3. Pull down and let go so that it is held only by the tension spring.
4. Tighten screws.
  - Inspect delivery belt after first season of use and re-tension as needed.
5. Visual Belt Tension Inspection
  - Belt tension can also be checked visually without performing the re-tension process.
    - a. Manually move belt in the correct direction from the return side of the delivery tube.
    - b. There should be no contact between tips of belt flights and face of delivery tube comb, ribs on scrubber block, or wall edge before seed sensor window.
    - c. Under-tensioned delivery tube belts will usually drag on these surfaces and can also exhibit outward spring around upper drive pulley.

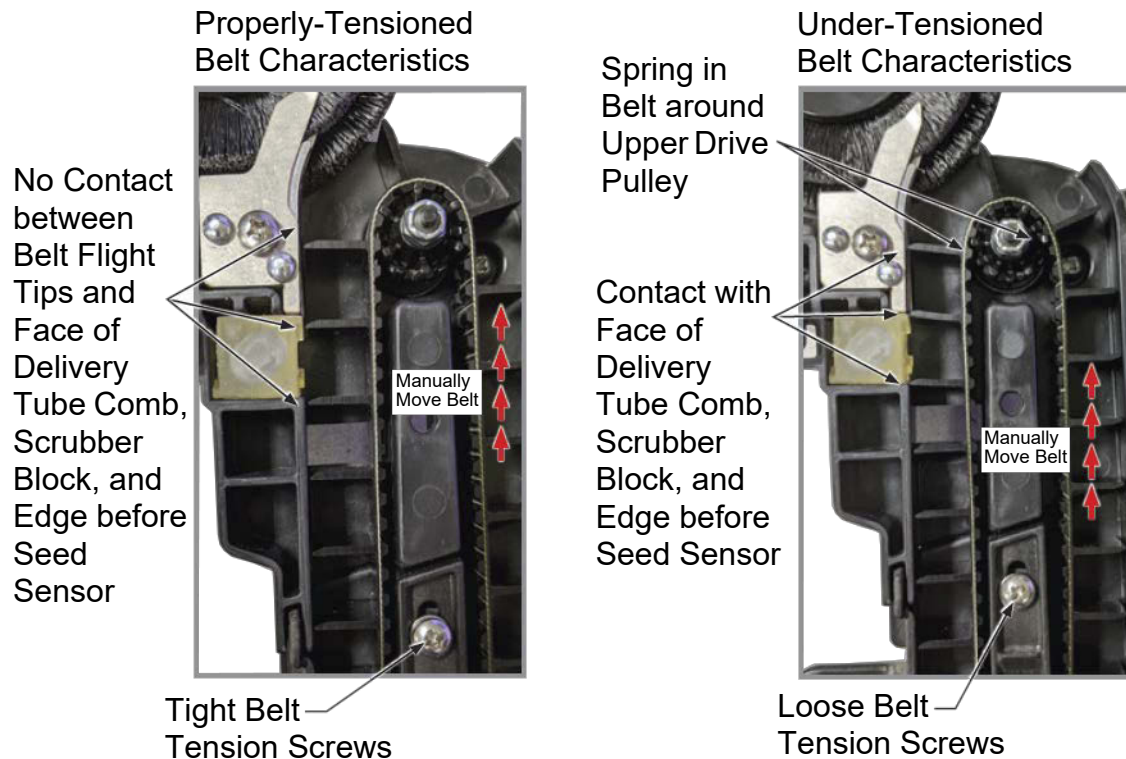

## Seed Belt Replacement

1. Lift release tab and slide lower housing cover downward. Lift and remove.
2. Push down and slide upper housing cover downward to disengage.

- 
3. Roll seed belt down and over idler pulley.
  4. Replace new belt by aligning on drive pulley and rolling onto lower idler pulley.
  5. Re-tension seed belt.
    - Clean drive pulley for proper belt alignment.
    - Seed belt flights should be oriented as shown.

## Brush Wheel Replacement

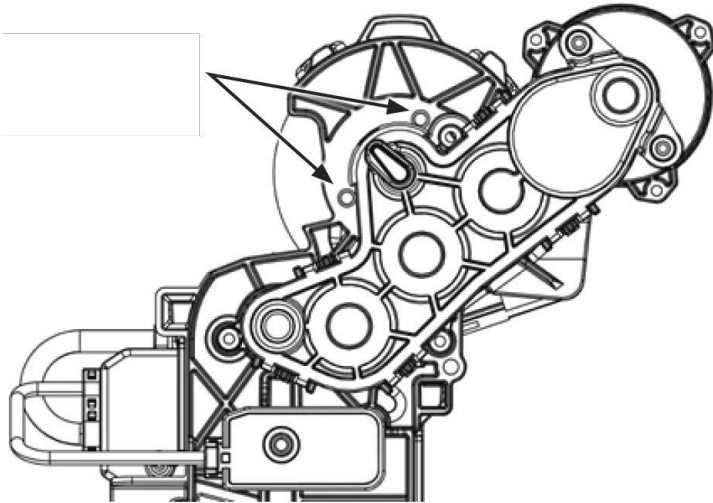

1. Remove retaining locknut on top of brush wheel.
2. Push brush wheel off of drive shaft by threading two seed sensor mounting screws into the brush wheel release holes (arrows shown above). Thread screws evenly on both sides to provide even pressure on brush wheel and prevent damage to shaft or wheel.

3. Replace new brush wheel and locknut. Use new locknut after brush wheel replacement.
  - Poor seed spacing could be caused by missing scrubber block in delivery tube assembly.
  - Be sure nothing is sitting/applying pressure to brush wheel.

## Diagnostics

### Troubleshooting Checklist

- **Dig test**

- Does the display reading match in ground performance?

- If no, inspect the delivery tube for blockages and clean the seed tube sensor.

- If so, continue to the next steps.

- **Is the row(s) reading a high amount of skips**

- Verify there is adequate seed in the hopper and seed pool

- If there is seed in the hopper, but little or no seed in the seed pool verify that the baffle setting is set properly for the selected crop type.

- Inspect for seed bridging and other blockages. If bridging is happening make sure to follow [Lubricant - Recommended Application Rate](#) on page 529.

- Verify that we have adequate vacuum pressure on the row(s). See [Vacuum Setting on page 515](#).
- Inspect disk for any damage or blockages.
- If planting soybeans, ensure that the singulator has been removed.
- **Is the row(s) reading a high amount of doubles**
  - Verify that the singulator is installed when using corn
  - Verify that the correct seed disk has been installed
  - Inspect the seed pool. If the seed pool is too full and overflowing the baffle setting may need to be lowered.
- **Other issues that can cause poor singulation.**
  - Verify that the ejector wheel is installed an the correct one is installed for the disk.
  - Inspect all components (disk, ejector wheel, singulator, vac seal, brush wheel, belt) for wear and tear.

## Check vacuum pressure level

- See [Vacuum Setting on page 515](#).

## Seed Pool Baffle

- See [Baffle Setting on page 515](#).

## Singulator

- See [Singulator Installed on page 515](#).

## Correct disk being used

- See [Seed Disc Kit on page 515](#).

## Ejector

- See [Ejector Wheel on page 515](#).

## Bulk Fill or mini hopper

- If mini hopper is used, is the door controlling seed pool (used for planting small plots) open or closed.
- When using bulk fill option ensure that the diffuser door is closed. If using mini hopper for small plot planting verify the diffuser door is open.

## Component wear and tear

- Is the brush wheel in good condition?
- Does the belt have any wear spots?

---

## Proper lubrication being used

- See [Lubricant - Recommended Application Rate on page 529](#).

## RCM II Run Switch



For troubleshooting individual rows, a magnetic run switch is available on all RCM II modules.

To activate and deactivate the run switch, place the magnetic end (A) of the seed depth tool (PN 4006424) on the RCM II at point (B). A magnetically activated switch will run both the

Meter motor and Delivery Tube motor for 1 minute or until deactivated.

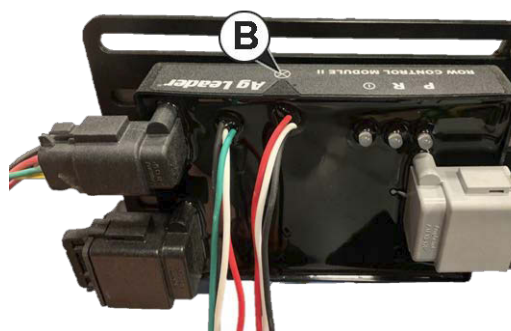

## Troubleshooting

PROBLEM	POSSIBLE CAUSE	SOLUTION
Low seed count.	Vacuum level too low.	Increase fan speed.
	Plugged orifices in seed disc.	Inspect and clean disc. Check remnant ejector.
	Loss of vacuum at meter.	Check for foreign material between vacuum cover and disc. Inspect parts for wear/damage. Clean or replace as required.
	Meter Speed too high for current settings	Reduce planting speed and increase vacuum setting.
	Seed sensor not picking up all seeds dropped.	Clean seed sensor lens and delivery tube.
	Brush wheel worn out	Replace brush wheel.
	Wrong seed disc or seed ejector.	Use appropriate disc and ejector for seed type and size.
	Seed size too large for current speed or vacuum setting.	Suggest decreasing ground speed or increasing vacuum.
	Meter engagement.	Check meter to delivery tube engagement.
	Vacuum seal worn.	Replace.
	Seed disc worn.	Replace.
	Worn remnant ejector.	Replace.
	Meter baffle door closed too far.	Mix talc thoroughly to coat all seeds. Set baffle to correct setting. Row Unit Operation section.
	Seed bridging in mini hopper.	Add graphite to improve seed flow.
	Failed/worn drive components.	Inspect and replace parts as required.
	Seeds sticking to seed disc.	Use graphite or talc to aid release.
	Seed treatment buildup in seed disc recesses.	Reduce amount of treatment used and or mix thoroughly. Add talc.
	Faulty vacuum gauge reading.	Repair/replace gauge.
	Dirt in vacuum manifold.	Check vacuum manifold for dirt and clean.
	Obstructed delivery tube exit.	Clean delivery tube exit.
Bulk fill pressure too low.	Increase bulk fill pressure.	
High seed count.	Vacuum level too high.	Decrease fan speed.
	Wrong seed disc.	Use appropriate disc for crop.
	Damaged or deformed belts.	Replace belt with new part.
	Baffle setting incorrect.	Lower baffle setting.
	Meter Speed too low for planting conditions or seed type.	Increase planting rate, planting speed, or decrease vacuum
	Meter overfilling with seed.	Decrease speed.
		Reduce meter baffle door setting.
Singulator not installed or installed incorrectly.	Install singulator.	

PROBLEM	POSSIBLE CAUSE	SOLUTION
Not planting seed.	Low/no vacuum.	Inspect vacuum system and repair as necessary.
	Worn ejector.	Replace ejector.
	Seed bridging in mini hopper.	Add graphite to improve seed flow. Adjust baffle setting
	Meter drive damaged.	Repair/replace drive components.
	Loss of vacuum at meter.	Check for foreign material between vacuum cover and disc. Inspect parts for wear/damage. Clean or replace as required.
	Seed baffle (if applicable) not allowing seed flow due to bridging of seed.	Mix talc thoroughly to coat all seeds. Remove seed baffle. Row Unit Operation section.
	High vacuum.	Adjust vacuum level to appropriate level
	Not stripping seed from the disc.	Replace brush wheel.
	Delivery tube plugged or damaged.	Clean or replace delivery tube.
	Faulty vacuum gauge.	Check gauge line for dirt/obstruction. Repair/ replace vacuum gauge.
	Wrong seed disc.	Use appropriate disc for seed type and size.
	Dirt in vacuum manifold.	Check vacuum manifold for dirt and clean.
Poor seed spacing.	Brush wheel worn.	Replace.
	Planting too fast for conditions.	Reduce speed.
	Obstruction in delivery tube.	Clean delivery tube.
	Wrong vacuum setting.	Adjust vacuum to appropriate level.
	Damaged singulator brush pack.	Replace singulator.
	Missing scrubber block.	Insert scrubber block into delivery tube assembly.
	Incorrect singulator state.	Add or remove singulator according to crop type.
	Excess foreign material in seed.	Inspect and clean meter and seed discs. Use clean, undamaged seed.
	Dirty/damaged seed disc.	Inspect seed disc for damage, foreign material in orifices or seed treatment buildup in recesses. Clean or replace.
	Incorrect baffle setting.	Set to recommended baffle setting.
	Toolbar not level or wrong height.	Adjust hitch to level toolbar and row units.
Irregular seed population.	Inspect for worn ejector wheel.	Replace as necessary.
	Dirty seed sensor lens.	Clean seed sensor lens and delivery tube.
	Rough field conditions.	Reduce speed.
	Check for worn comb teeth.	Replace as necessary.
Unable to achieve desired vacuum level.	Vacuum hose pinched/kinked/blocked.	Inspect air lines for any damage or obstruction. Clean air lines and manifold by removing end cap from manifold and running fan at high speed.
	Damaged fan components.	Inspect motor and impeller for wear/damage and repair/replace as necessary.
	Vacuum hose loose/disconnected.	Inspect and reattach all air hoses.
	Dirt in vacuum gauge line.	Check gauge line for dirt/obstruction and clean.
	Abnormally high vacuum required or consistent operation cannot be achieved.	Replace seed disc or vacuum seal.



## Technical Specifications

Do not exceed the specifications below:

- Storage Temperature: -40 to +158 °F (-40 to +70 °C)
- Operating Temperature: 32 to +131 °F (0 to +55 °C)
- Operating Input Voltage: 18 –32 V DC
- Max Current Rating:
  - 4 Amps for Meter Motor (4006033)
  - 4 Amps for Delivery Tube Motor (4006034)
  - 12 Amps for RCM II (4005896)
- Fuse: Blade Style (ATO/ATC)
- Environmental Protection Rating: IP65
- No Protective Grounding required
- Use 150V minimum insulation rating for external circuits

Exceeding these specifications may result in degraded operation and/or damage to the meter system.

# Parts List

## Delivery Tube

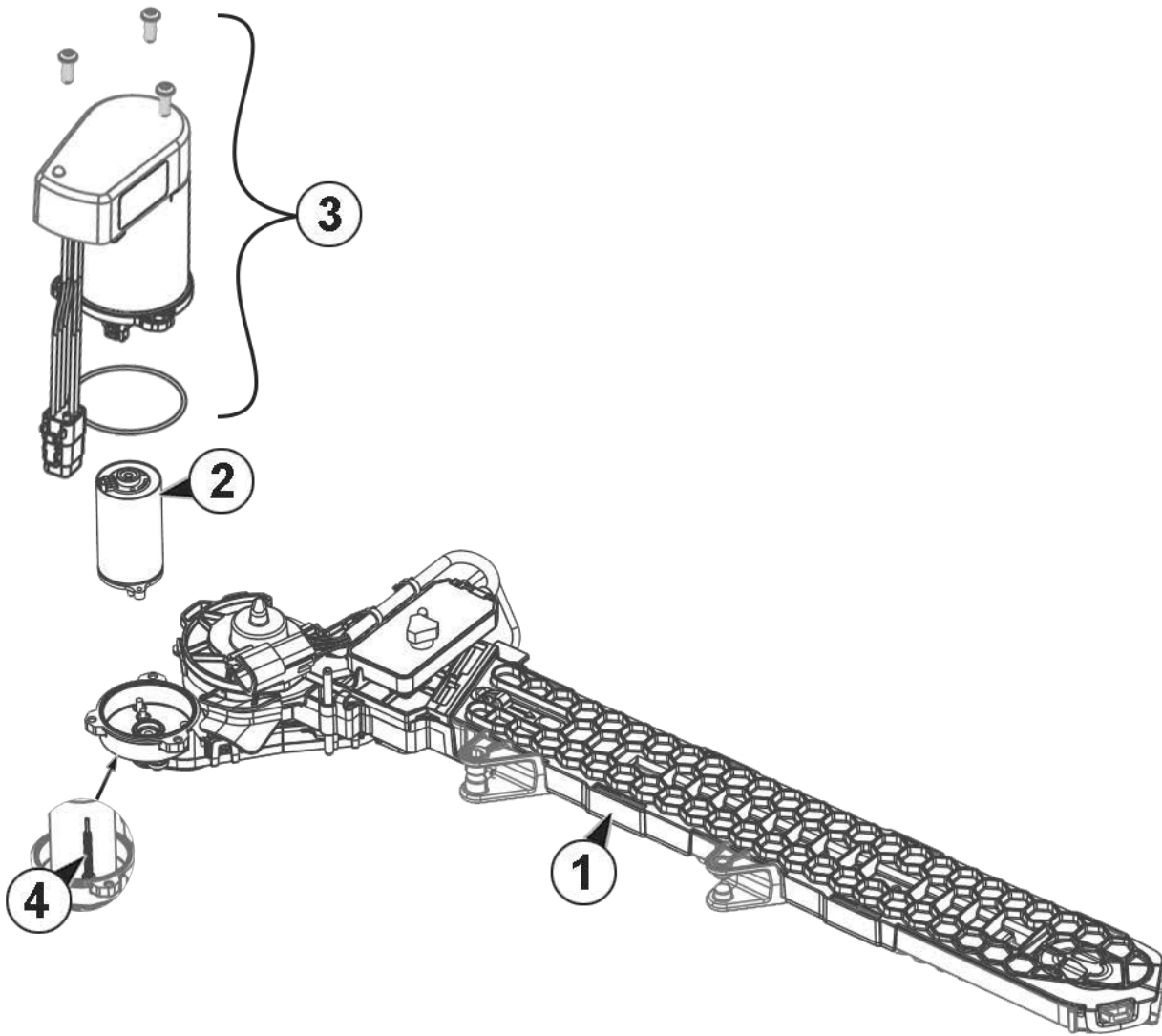

ITEM	PART NO.	QTY .	DESCRIPTION
1	4006281	1	Seed Delivery Tube - not a repair part
2	4006564	1	Motor repair kit. Used for meter and delivery. Includes motor, screws, felt washer (not used on delivery tube), foam ring (not used on delivery tube).
3	4006604	1	Delivery Motor Driver kit. Includes motor driver, screws, and O Ring
4	4006524	1	Internal Grounding Screw

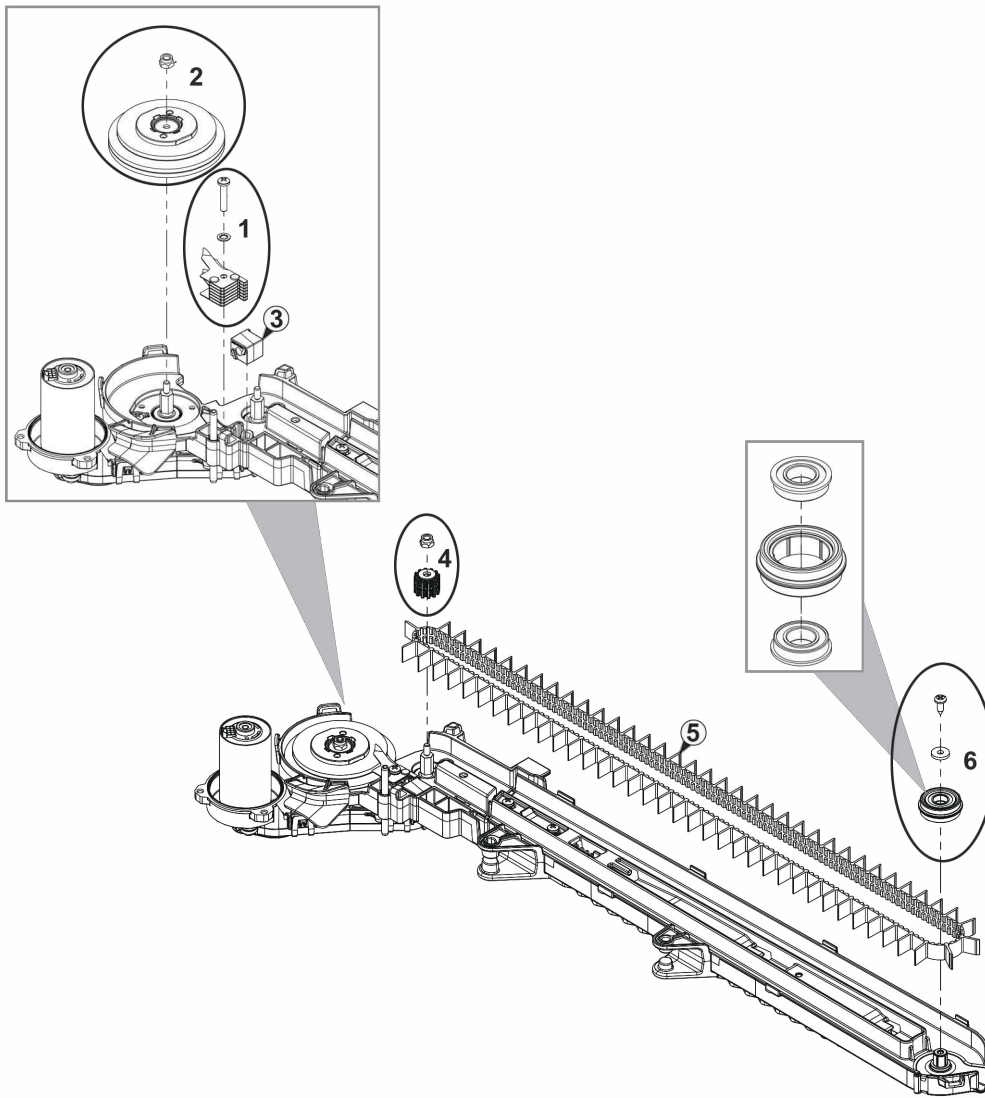

ITEM	PART NO.	QTY .	DESCRIPTION
1	4006576	1	Stripper Wheel Comb Assembly, includes washer and screw
2	4006568	1	Brush Wheel Assembly, includes wheel and hex nut
3	GB1257	1	Seed Relief Scrubber
4	4006570	1	Belt Drive Sprocket, includes wheel and hex nut
5	GB1256	1	Seed Delivery Belt
6	4006574	1	Seed Delivery Idler Pulley Assembly, includes washer and screw

(A27001)

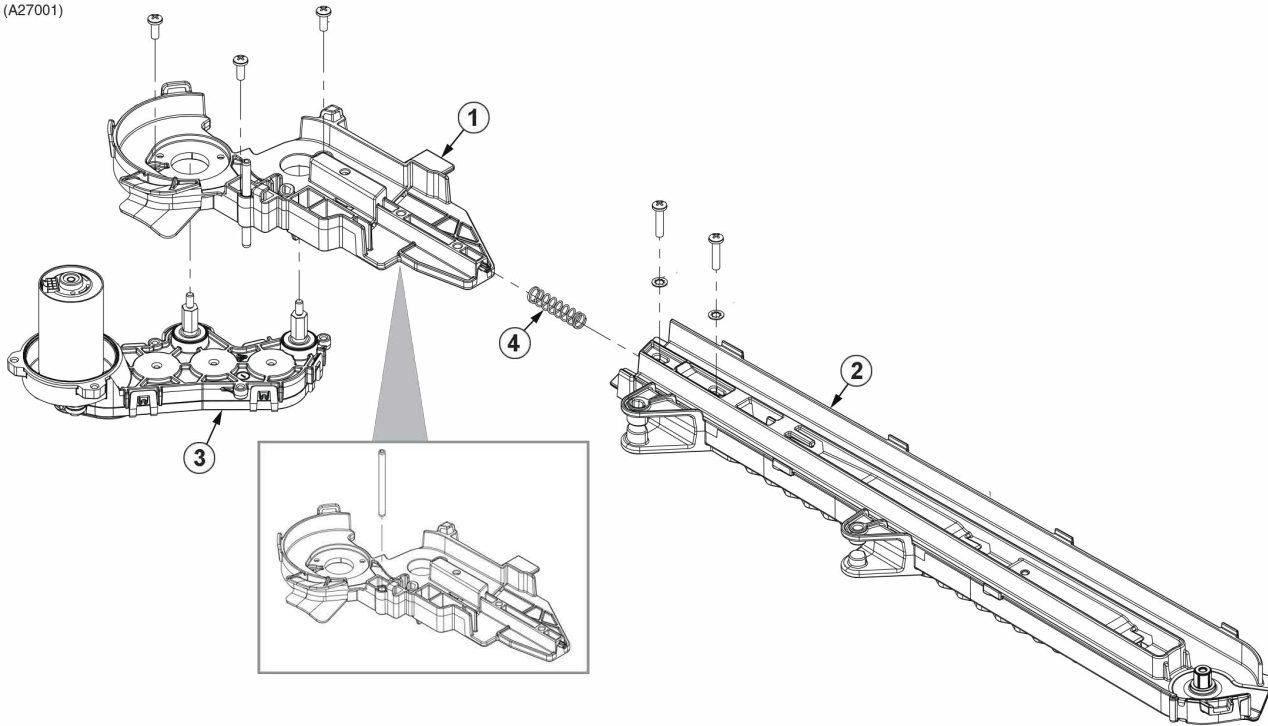

ITEM	PART NO.	QTY .	DESCRIPTION
1	GA27133	1	Upper Housing Assembly, includes housing and roll pin
2	GA27084	1	Lower Housing Assembly, includes steel clip
3	4006573	1	Gearcase Assembly, includes screws
4	GD36938	1	Belt Tensioner Spring

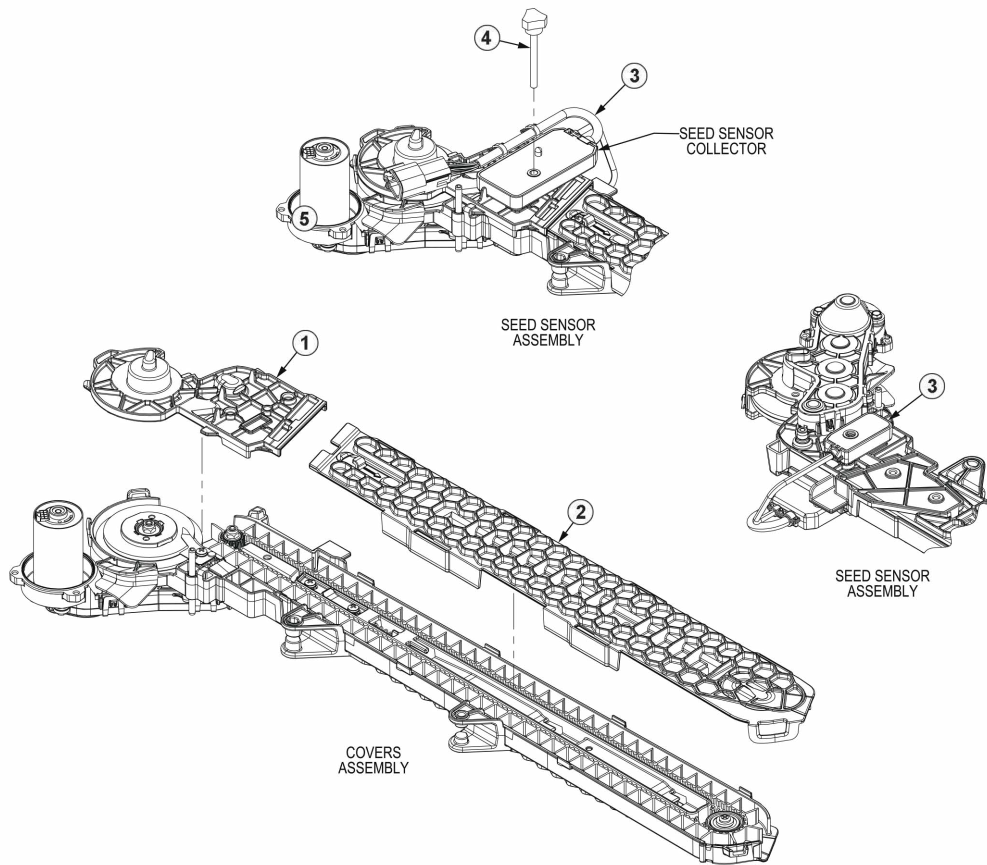

ITEM	PART NO.	QTY .	DESCRIPTION
1	G10208301	1	Cover, Seed Delivery Upper
2	GB1251	1	Cover, Seed Delivery Lower
3	GA27003	1	Seed Sensor Assembly
4	G10060401	1	Thumb screw

# Meter

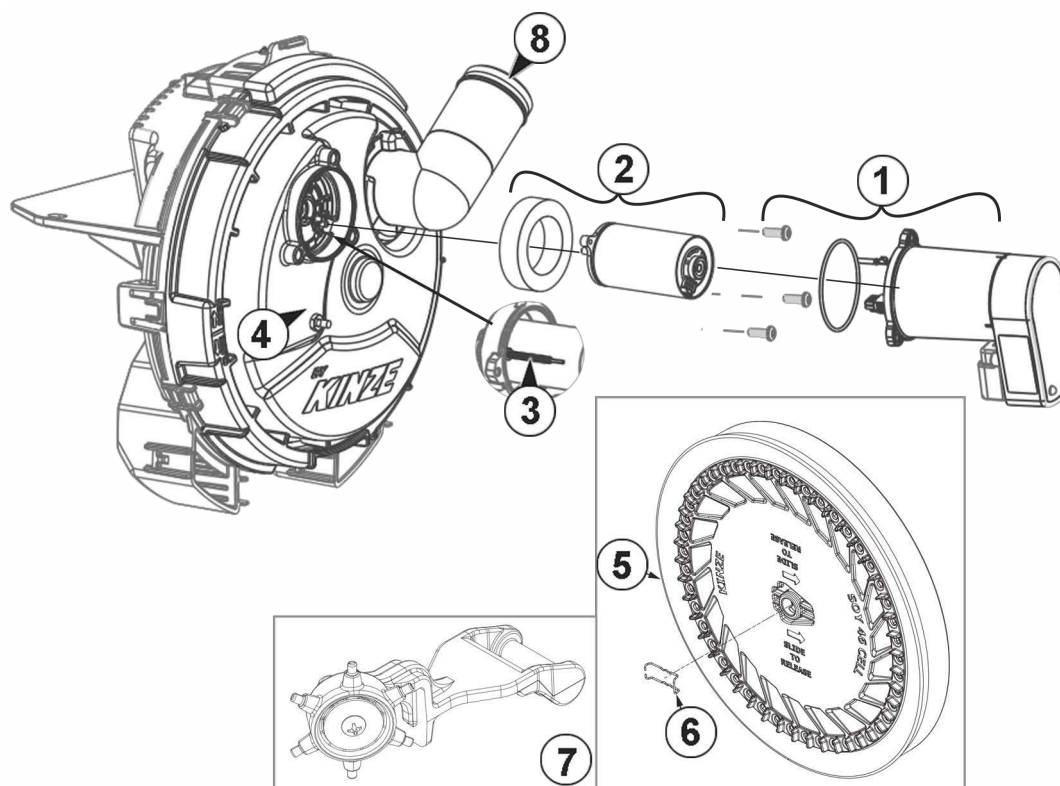

ITEM	PART NO.	QTY .	DESCRIPTION
1	4006605	1	Meter Motor Driver kit. Includes motor driver, screws, and O Ring.
2	4006564	1	Motor repair kit. Used for meter and delivery. Includes motor, screws, felt washer (used on meter only), foam ring (used on meter only).
3	4006524	1	Grounding Screw
4	A27011	1	Meter Housing - not a repair item
5		1	Seed Disc, See <a href="#">Crop Settings on page 515.</a>
6	10478701	1	Seed Disc Retention Clip (Included W/Item 6)
7		1	Ejector (Included W/Item 6) See <a href="#">Crop Settings on page 515.</a>
8	4006569	1	Elbow, SureSpeed KZ Vac
(parts not shown)	4005968-1	1	Vac Hose End 1.25" ID
	4005968-3	1	Vac Hose End 1.50" ID
	4005968-2	1	Vac Hose End 2.00" ID
	B1249	1	Kinze 4k Vac Hose End

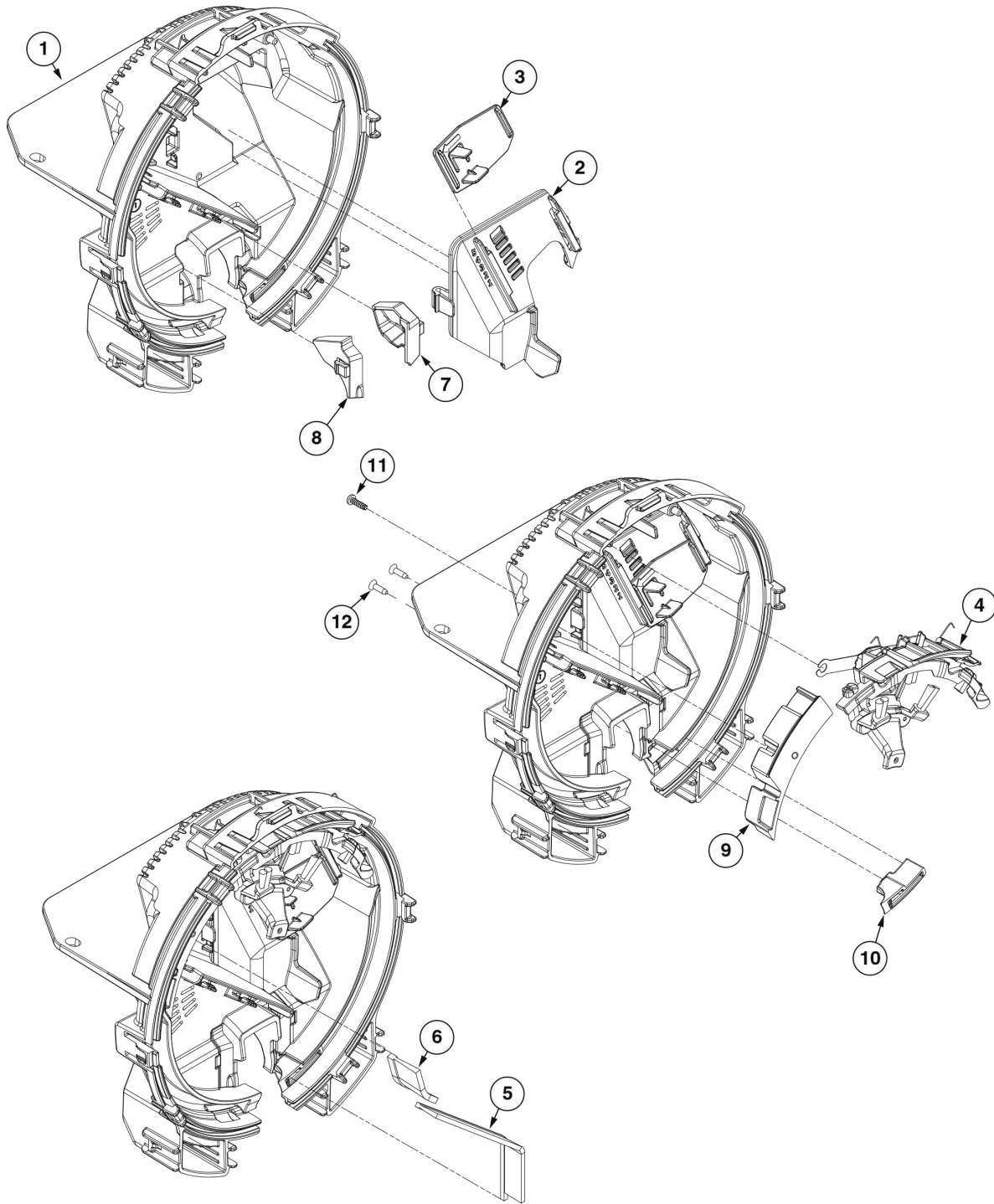

ITEM	PART NO.	QTY .	DESCRIPTION
1	G10208401	1	Housing - Meter
2	GB1275	1	Meter Baffle
3	GB1276	1	Door Baffle
4	GA27013	1	Singulator Assembly
5	GD36954	1	Meter Wall Brush, Small
6	G10459801	1	Meter Wall Brush, Large
7	B1307	1	Plug - Meter Housing
8	B1306	1	Plug - Meter Housing
9	4006571	1	Upper Seed Relief Insert
10	G1K784	1	Lower Seed Relief Insert
11	2002285-06050	3	Phillips Pan Head Tapping Screw, No. 6-19 x 1/2"

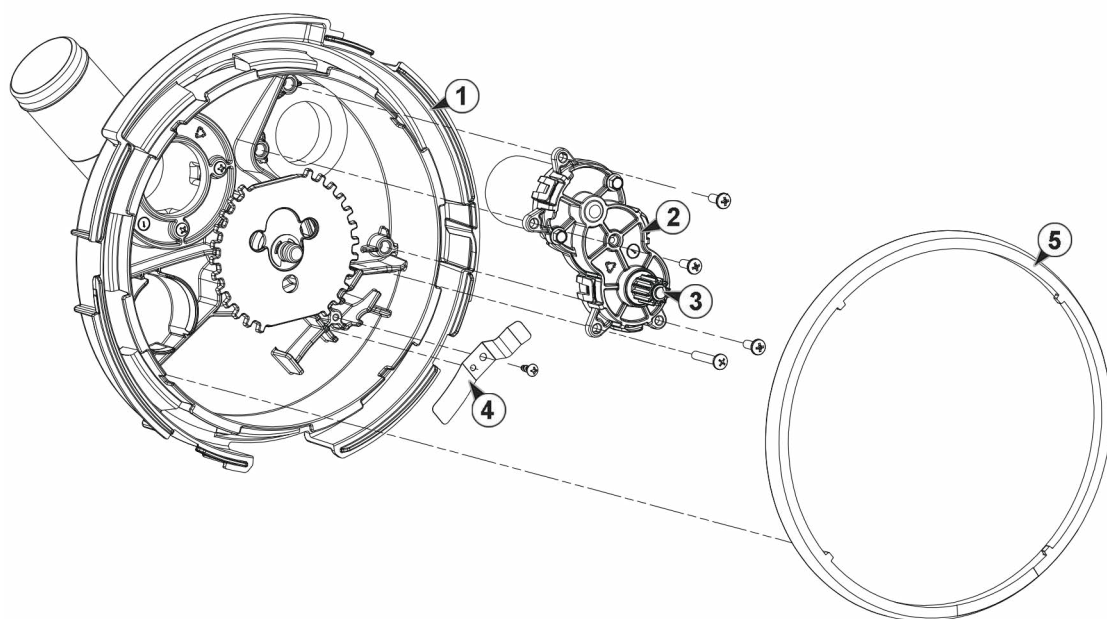

ITEM	AG PART NO.	QTY .	DESCRIPTION
1	G10193603	1	Meter Cover W/Bearing Assembly
2	4006575	1	SureSpeed Meter Gearbox
3	4006565	1	Pinion Gear with Retaining Ring
4	4006567	1	Ejector Arm Retention Spring with screws
5	GB1282	1	Meter Seal



Klnze 4000 Series Hopper

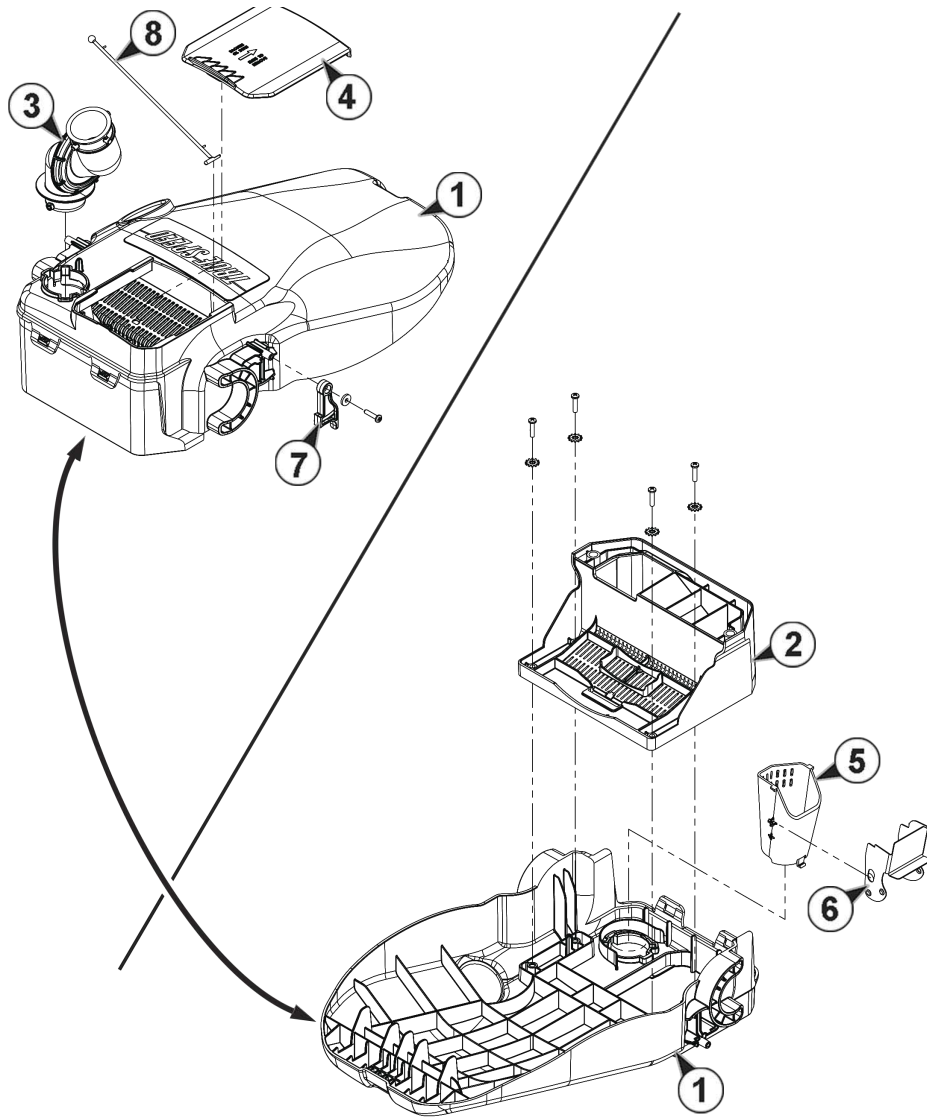

ITEM	PART NO .	QTY .	DESCRIPTION
1	10201003	1	Mini-HopperCover
2	B1240	1	Mini-Hopper
3	A26999	1	Elbow, Swivel, Kinze 4000 series
4	B1242	1	Mini-Hopper Lid
5	10506301	1	Bulk Fill Diffuser
6	10199801	1	Diffuser Door
7	B1246	1	Latch
8	B1247	1	Tether

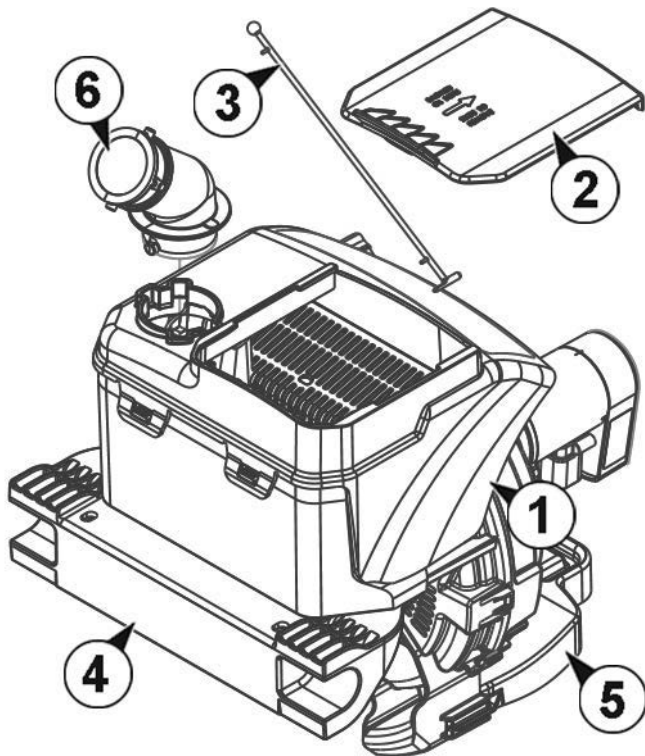

ITEM	PART NO .	QTY .	DESCRIPTION
1	B1240	1	Mini-Hopper
2	B1242	1	Mini-Hopper Lid
3	B1247	1	Tether
4	4005941	1	John Deere
	4006002	1	Kinze 3000 Series
5	4005965	1	Rear Bracket
6	A26999	1	ASD Inlet Swivel (KZ)
	4006895	1	Vented Swivel

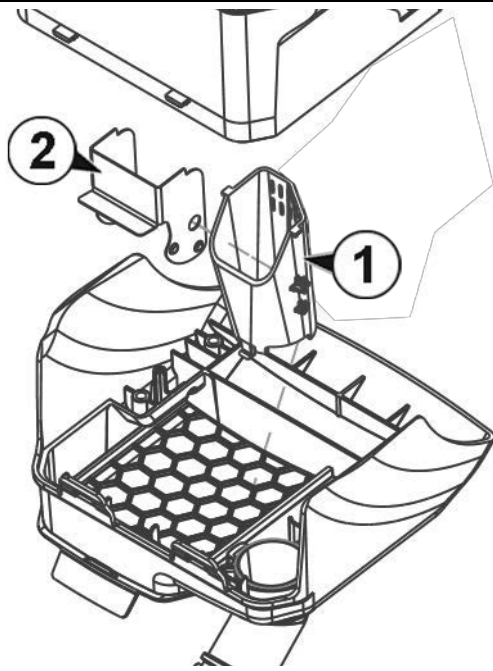

ITEM	PART NO .	QTY .	DESCRIPTION
1	10506301	1	Bulk Fill Diffuser
2	10199801	1	Diffuser Door

# John Deere Mini-Hopper

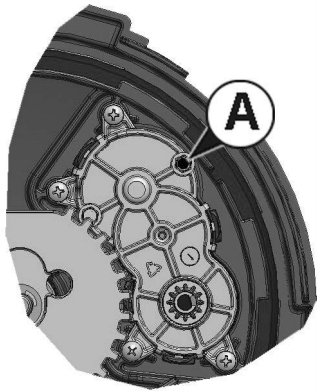

View From Inside Meter

ITEM	PART NO	QTY	DESCRIPTION
A	4006524	1	Grounding Pin/Screw SureSpeed

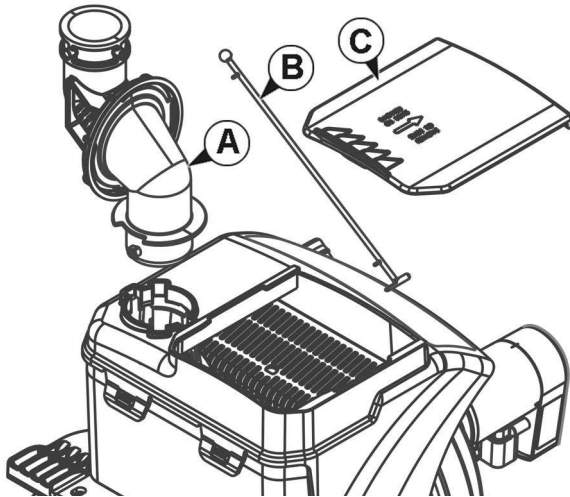

ITEM	PART NO	QTY	DESCRIPTION
A	4006895	1	JD CCS Swivel Assembly
B	B1247	1	Tether
C	B1242	1	Mini-hopper Cover

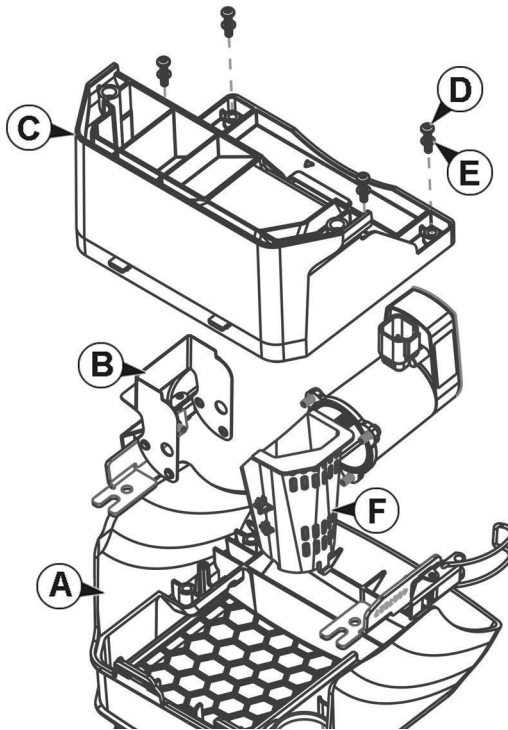

ITEM	PART NO	QTY	DESCRIPTION
A	4005935	1	Cover - Mini Hopper
B	10199801	1	Door Diffuser
C	81240	1	Base - Mini Hopper
D	2002104-08075	4	Machine Screw, Torx Pan Head, #8-32X3/4 inch
E	2002213-08	4	Lock Washer, Intern Tooth, SS, #8
F	10506301	1	Diffuser ASD

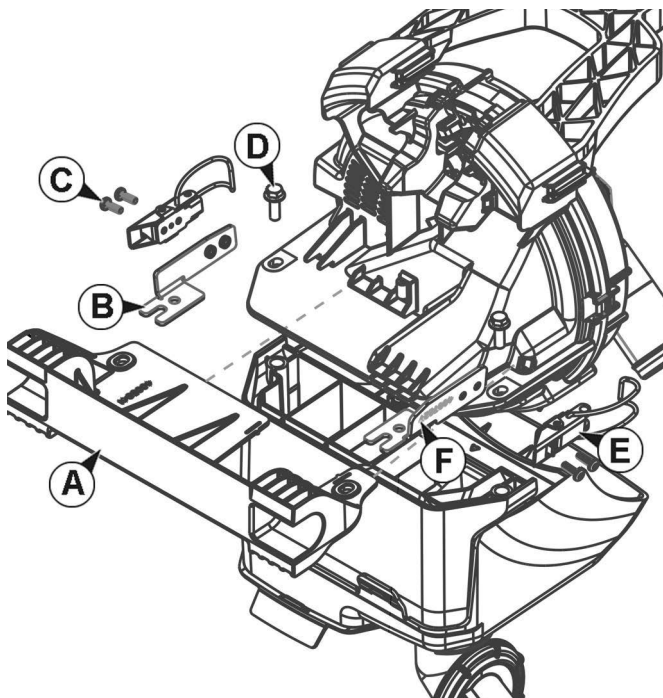

ITEM	PART NO	QTY	DESCRIPTION
A	4005941	1	Front Pivot Bracket
B	4007190	1	Left Latch Mount
C	2002104-08050	4	Machine Screw, Torx Pan, #8-32X1/2 inch
D	2002405-25075	2	Serrated Flange Screw 1/4-20X3/4 inch
E	4007577	2	Latch
F	4007227	1	Right Latch Mount

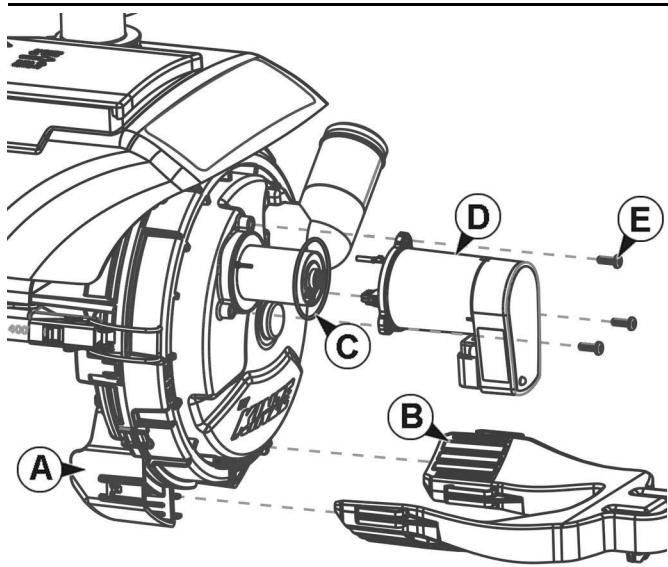

ITEM	PART NO	QTY	DESCRIPTION
A	109725	1	SureSpeed Meter
B	4005965	1	Rear Meter Bracket
C	2002259-033	1	O-ring
D	40060034	1	Meter Motor Driver
E	2002104-08050	3	Machine Screw, Torx Pan, #8-32X1/2 inch

SureForce™ uses sensors to measure the weight carried by the gauge wheels. This information is used to adjust the down force so the planter is firmly on the ground, ensuring correct planting depth and reducing the risk of compaction. Individual Row Hydraulic Down Force control is only available with the InCommand™ 1200 display.



**DANGER!** Do not service the down pressure system with the tractor hydraulic system active because sudden movement of row units can occur.

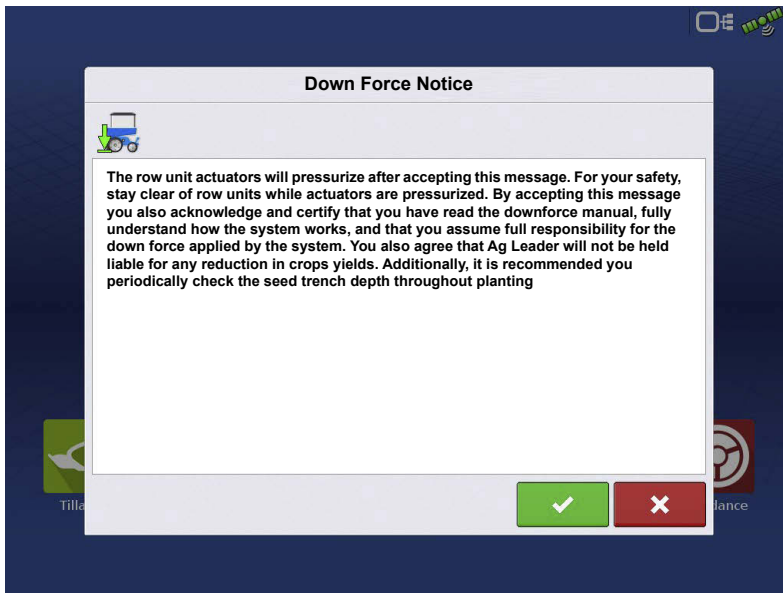

Upon starting the display, you will receive the Down Force Notice that will need to be accepted in order to operate the Hydraulic Down Force system.

## Load Configuration



Press the Planting App from the home screen. This will take you through the steps needed to load a configuration.

# Map View

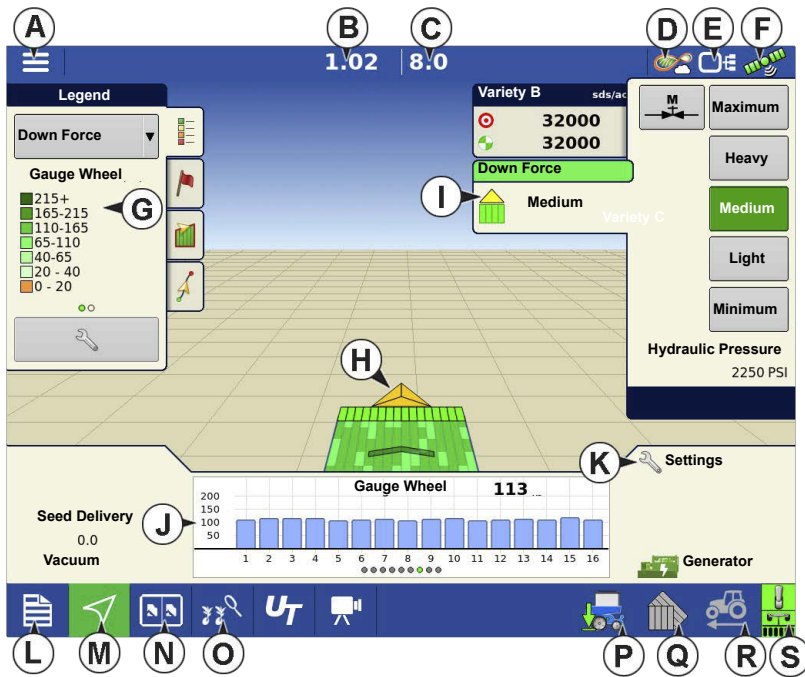

Once a configuration has been completed, the Map View screen appears.

- A.Menu button
- B.Total Logged Field Area
- C.Ground Speed
- D.AgFiniti® Status Indicator
- E.Diagnostics
- F.GPS Signal Indicator
- G.Display Legend
- H.Vehicle Icon

I. Down Force Setting

J. Bar Graph

K. Settings button

L. Event Summary

M. Map View

N. Split screen

O. Advance Seed Monitoring

P. Down Force Icon

Q. AutoSwath

R. Jump Start

S. Master Switch Status

Real time individual row down force data is available on the Map View screen; both Gauge Wheel load and Supplemental Force data is mapped. To display either the Gauge Wheel load or Supplemental Force, select Down Force from the Legend tab. Then swipe the Display Legend (G) left/right to change between Gauge Wheel load and Supplemental Force.





**NOTE!:** Pressing the Map View button will cycle between the available Map Screen views, and the appearance of the Map View button changes.

## Bar Graphs on Run Screen

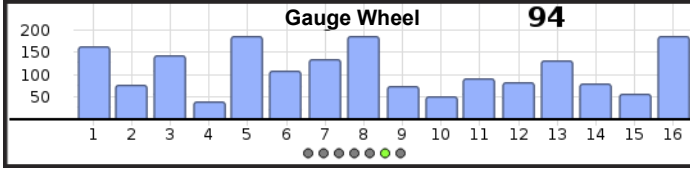

Bar Graphs on Run Screen show **Gauge Wheel Load** and **Down Force** being applied to row unit. Swipe bar graph to advance to next graph. Bar graph may also contain graphs for Advanced Seed Monitoring.



Down Force is not shown when in Monitor Only mode.

## Advanced Seed Monitoring

Press: Advanced Seed Monitoring button



The screenshot shows a 3D view of a planter on the left and a data panel on the right. The data panel includes:

- A:** All Rows button
- B:** Bar Graph showing Down Force trends
- C:** Population: 69300 seeds, Singulation: 95.9%
- D:** Skips: 1, Doubles: 2.6%
- E:** Spacing Quality: 97.1%, Seed: 6.1
- F:** Meter Speed: 72.8
- G:** Gauge Wheel/Down Force summary: Gauge 157, Down Force: 204
- H:** Down Force Trends graph
- I:** Previous/Next Row Toggle
- J:** Seed Monitor Options

## Planter Performance screen

- A. All Rows
- B. Bar Graph
- C. Population/Singulation
- D. Skips/Doubles
- E. Spacing Quality/Seed Spacing
- F. Meter Speed
- G. Gauge Wheel/Down Force
- H. Down Force Trends

I. Previous/Next Row Toggle

J. Seed Monitor Options

Advanced Seed Monitoring provides planter performance monitoring of seed meter singulation, skips/doubles and spacing quality, along with population and spacing information for all rows when planting compatible crops.

In addition, Advanced Seed Monitoring automatically determines and displays the rows operating at the highest and lowest levels for singulation and population. The screen also shows the averages for specific drive sections.

Bar graph can show individual row information for the averages shown on buttons (C, D, E, G, H).

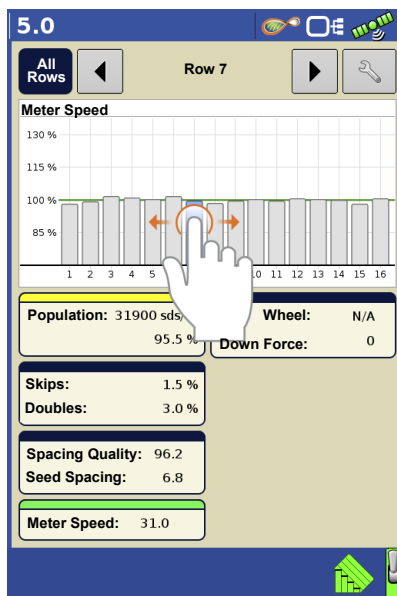

**A. All Rows**—Planter average for display items (C, D, E, G, H) at the bottom of the screen.

**B. Bar Graph**—Displays population, singulation, spacing quality, skips, and doubles, as selected by the operator.



**NOTE!** An operator may also touch the appropriate bar on the graph to show that specific rows Advanced Seed Monitoring values. To easily change between specific rows, tap and hold your finger on the bar graph, then drag left or right between rows. Release your finger from the screen when the desired row is highlighted.

**C. Population**—Displays the average population for the planter, or sections of the planter, along with the highest and lowest population row.

**Singulation**—Displays the average Singulation for the planter, or selected sections of the planter, along with the highest and lowest rows.

- Singulation is a measure of the percent of seeds being properly metered so that one and only one seed drops from each seed cell of the seed meter.

**D. Skips/Doubles**—Displays the average skips and doubles for the planter

- Skips are a measure of the percentage of seed expected to be planted that are not due to a seed not being dropped by the seed meter.
- Doubles are a measure of the percentage of seed expected to be planted individually but instead two or more are dropped by the seed meter.

E. **Spacing Quality**—Displays the average spacing quality for the planter, or selected sections of the planter, along with the highest and lowest.

- Spacing quality is a measure of the percent of seeds being properly placed so that the spacing is as expected in the seed trench.

F. **Meter Speed**—Displays row by row meter speed.

G. **Gauge Wheel/Down Force**—Displays the average Gauge Wheel load on the planter and average Downforce or Uplift applied.

H. **Down Force Trends**—Displays how far the gauge wheel load is off (+/-) from the target as a percentage.

- Trending towards the feather icon means the gauge wheel load is lower than the target.
- Trending towards the weight icon means gauge wheel load is higher than the target.

I. **Previous/Next Row Toggle**—Toggle through the rows using the arrow buttons or press on a specific row in the bar graph to show specific Advanced Seed Monitoring values for that row.



J. **Seed Monitor Options**—Pressing this button brings up Seed Monitor Options screen.

## Down Force Status

Button on the lower right side of Map Screen shows the status of Down Force.



**Active** - Hydraulic Down Force is in an Active state - automatically controlling the down force per channel based on the gauge wheel load readings. To be Active, the implement switch needs to be in a planting state, speed needs to register on the display greater than 0.5 mph (0.8 km/h), and the tractor hydraulics engaged.



**Inactive or Hold** - Hydraulic Down Force is in an Inactive state or Hold state. Planter is either raised, the display is not registering speed, or the implement is in an AutoSwath area.



**NOTE!:** With AutoSwath active, the entire planter bar will need to be in a previously applied area or boundary area in order for all rows to Hold the Supplemental Force.



**Manual Mode** - Hydraulic Down Force is in Manual Mode. Manual Mode can be activated from the Planter Options screen.



**Manual Hold** - Hydraulic Down Force is in a Hold state - this Hold state is activated by the operator by toggling the Down Force icon. **The Hydraulic Down Force can only be set back to an Active state by toggling the Down Force icon again.**



**NOTE!:** Manual Hold can be a useful tool for operators who wish to Hold down force in certain areas of their fields, instead of letting the Hydraulic Down Force system actively control in these said areas.

## Planter Options Screen

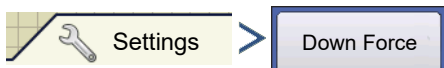

OR

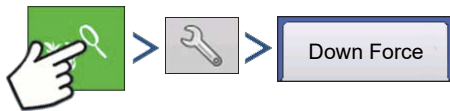

	Gauge Wheel	Down Force
1	80.2 lb	206.5 lb
2	75.0 lb	207.1 lb
3	80.2 lb	195.3 lb
4	81.7 lb	210.5 lb

Gauge Wheel Load  
Standard  
3 - Medium (Default)



Selecting Automatic Control enables the system to control down force based on gauge wheel sensor readings.

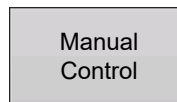

Selecting Manual Control enables the operator to set the downforce as they

see fit.

**Gauge Wheel**—Instantaneous gauge wheel load for each row. This is a raw sensor reading; it can be used for diagnostic purposes.

**Down Force**—Instantaneous supplemental down force for each row.

## Gauge Wheel Load

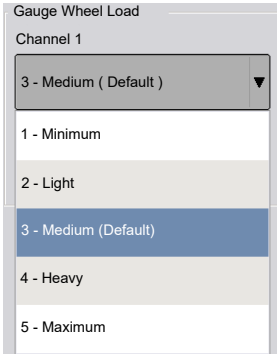

Each SureForce setting has an associated target for gauge wheel load and ground contact.

SureForce Setting	Target Gauge Wheel Load
Minimum	50 lbs
Light	75 lbs
Medium	100 lbs
Heavy	150 lbs
Maximum	200 lbs

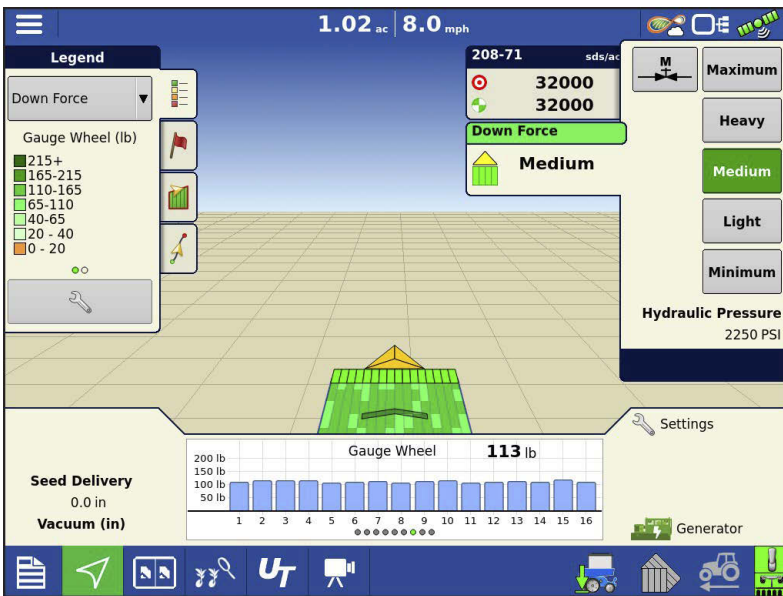

**NOTE!** The gauge wheel load settings can also be accessed from the rate groups on the right side of the runscreen.

Target gauge wheel load will be overridden by SureForce when ground contact measurements are less than target. Ground contact is determined by monitoring gauge wheel load over time as the planter

travels through the field.

Default setting is Medium and is recommended as a starting point for all planters, field conditions, and crops.



**WARNING!** When operating on light or minimum, shallow planting can occur.

---

## Create Configuration

A wizard will guide you through the process of selecting or creating a configuration with application settings.

The configuration can be started in two places:



OR



Your Operating Configuration will then be viewable when you start a new Field Operation with the Application Wizard.

You can also use the **Manage Equipment** button to create or edit specific vehicles and implements.

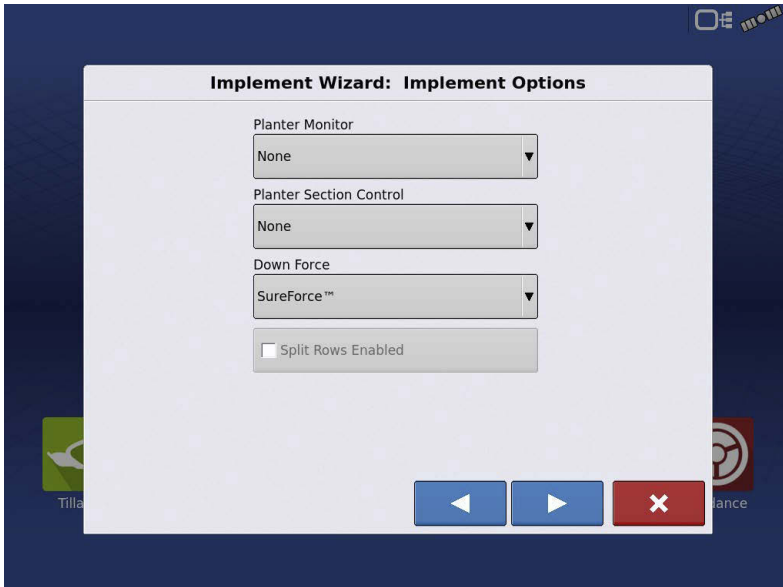

At the **Implement Options** screen, choose SureForce from the Down Force drop down menu:

## Setup Down Force Configuration

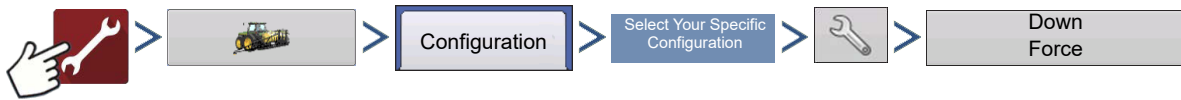

### General tab

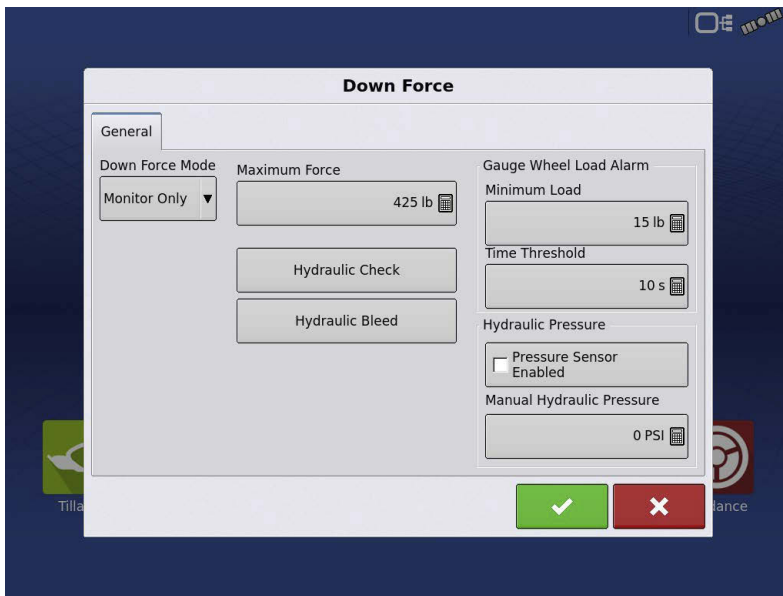

#### Down Force Mode

**Monitor Only mode**—provides the operator with information to determine if the row units are properly engaging the soil. If they are not, the operator needs to adjust the planter to correct the situation.

- Allows user to monitor the weight on the gauge wheels but does not adjust down pressure.

- Control related settings are grayed out when using Monitor Only mode.

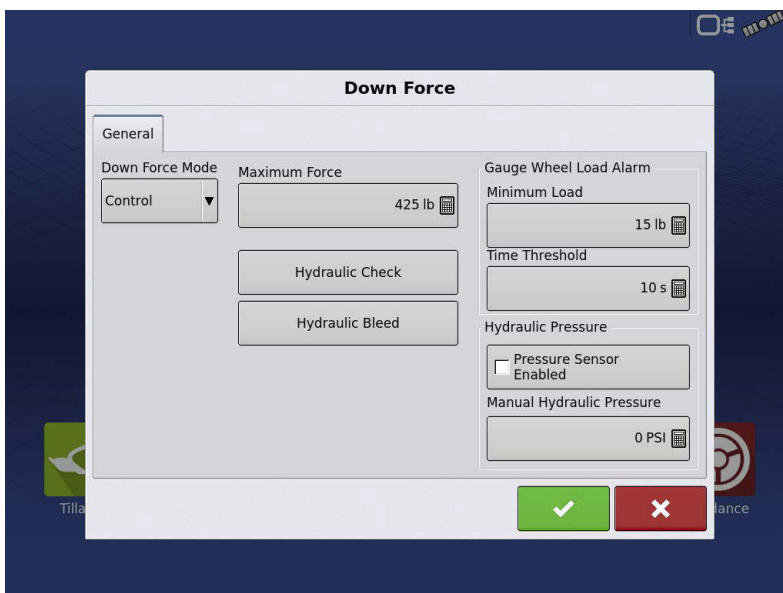

**Control mode**—as the planter travels across the field and encounters varying soil conditions (soil types, compaction zones, levels of debris) the display makes adjustments to the down force actuators on the row units, according to the gauge wheel load and the operator's settings, to maintain the correct seed placement in the soil.

---

**Maximum Force**—used to limit the down force created by the actuator.

**Hydraulic Check**—used by technician for diagnostic purposes.

## Hydraulic Bleed

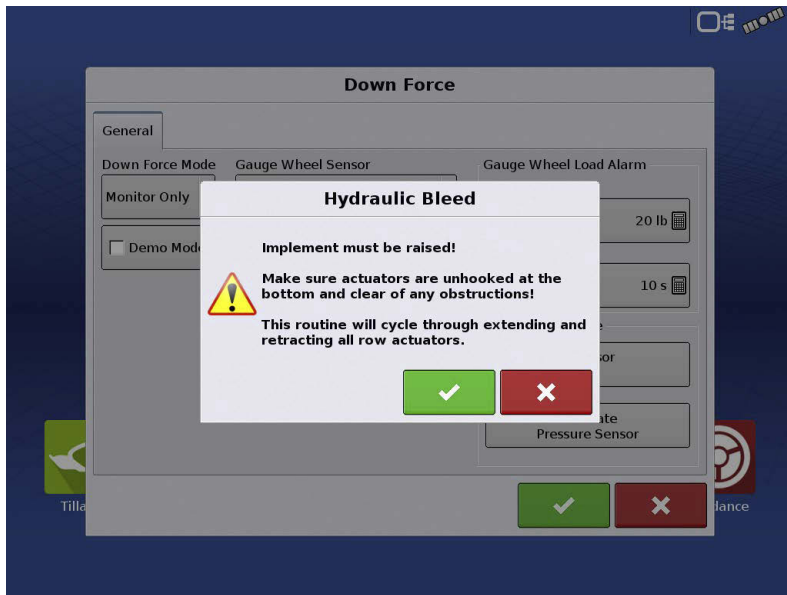

Used to bleed air from the SureForce system.



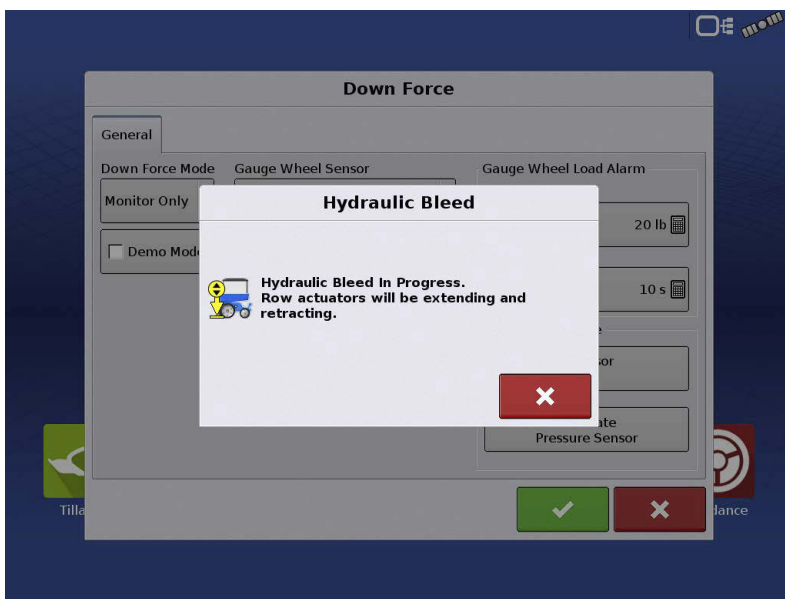

**Gauge Wheel Load Alarm**—sets alarm to notify operator when system goes below Minimum Gauge Wheel Load for a set amount of time (Time Threshold).

## Calibrate Pressure Sensor

(Only able to calibrate when Control Mode has been selected)

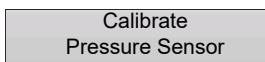

If the Hydraulic Pressure (PSI) reading in the Planter Control Master Module diagnostic screen is not accurately reflecting the pressure sent to the control valve, the operator can proceed to calibrate the pressure sensor in attempt and correct the PSI reading.

## Calibrate Pressure Sensor:

1. Verify hydraulic pressure to the control valve is at 0 PSI. This can be achieved by turning the vehicle off, or disengaging SCV remote.

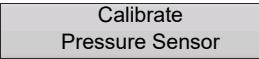
2. Press 



**NOTE!:** No dialog or messages will appear when Calibrate Pressure Sensor is pressed.

3. Pressure sensor is now calibrated.

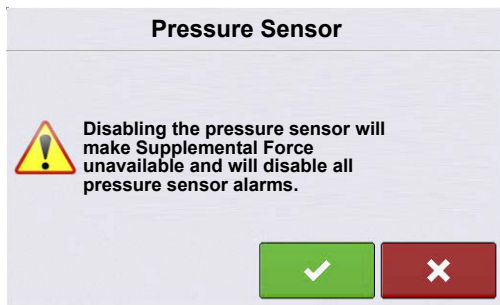

**ATTENTION!:** If the Pressure Sensor Enabled box is unchecked, a warning message will appear. With the pressure sensor disabled, automatic down force control will still work as intended. However, there will be no Supplemental Force value, graphs, or pressure sensor

alarms.

## Advanced tab



In order to access the Down Force Advanced tab, a configuration must be loaded. In the Advanced tab operator can disable a Load Pin or Down Force control, edit the row unit Linkage Type, and set a Target Force for Disabled Rows.

**Control Toggle** – This allows the operator to indicate if a row has hydraulic down force control. Pressing this button will change the Control

status to "Yes" or "No". Multiple rows can be selected together when toggling the control.

**Load Pin Toggle** — This allows an operator to disable a gauge wheel sensor if one fails in field or enable a sensor to just monitor a row. Pressing this button will change the “Enabled” status for that specific Load Pin to “Disabled”. Multiple rows can be selected together when disabling/enabling gauge wheel sensors.

**Load Pin & Linkage Type** — This allows the operator to change the row unit Linkage type and Load Pin type. It is possible for planters to have a combination of load pin types and linkage types. Both options can be selected independently per row if necessary. Multiple rows can be selected at once by tapping and highlighting or pressing the All Rows button.

**Target Force for Disabled Rows** — This allows the operator to set a target Supplemental Force for a row with a Disabled Load Pin. For example, if row 1 is Disabled and 250lbs is entered in this box as the Target Force, row 1 will apply a constant 250lbs of Supplemental Force. The remaining Enabled Rows will continue to function in automatic control mode.

**WARNING!:** It is recommended to enter a Target Force for Disabled Row when a row(s) are Disabled. If this value is left at 0lbs, the Disabled row(s) will apply 0lbs of Supplemental Force.

## Monitoring Planter Rows in Conjunction with Controlled Rows



Individual Row Down Force allows the ability to monitor just gauge wheel load on some planter rows while continuing to hydraulically control the rest of the rows.

Example: A split row planter is setup to control down force on the standard rows, but also setup to just monitor gauge wheel load on the split rows. Split rows that have gauge wheel sensors will need to be set to No for

Control, and Enabled for Load Pin. (Split rows that don't have a gauge wheel sensor will need to be set to No for Control, and Disabled for Load Pin.) All standard rows will need to be set to Yes for Control, and Enabled for Load Pin.

## Diagnostics Screen

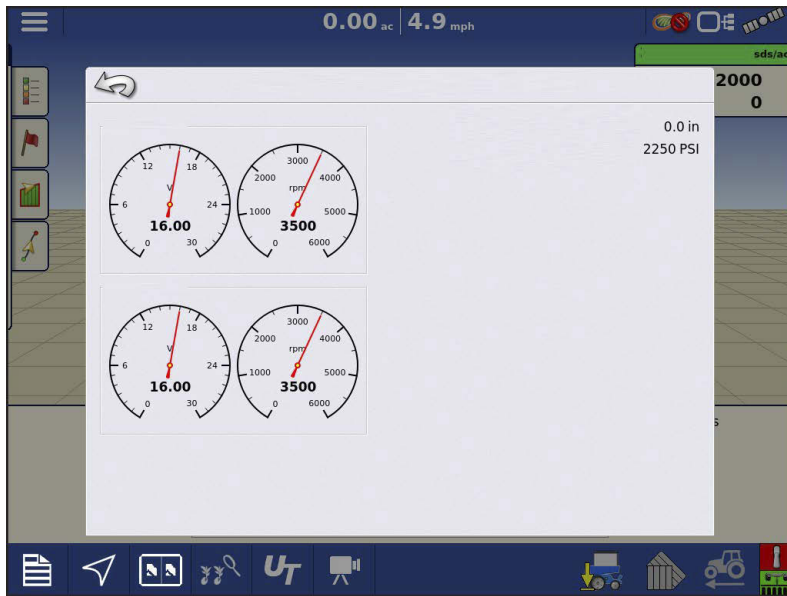

Pressing on the CAN button, located in the upper right corner of the display, opens the **Devices** screen. Highlight the **Planter Control Master Module** in the CAN B tab and press the **Diagnostics** button in the lower right-hand corner. Technical support may request that you look at these screens for help in diagnosing a problem.

In this screen you can view the current **Hydraulic Pressure**. This is the input pressure to the valve block.

## Down Force Alarms

### SureForce/SureDrive Voltage Alarms

When a SureDrive/SureForce system loses voltage 2 different voltage alarms can appear. The Down Force Low Voltage alarm and the Low Voltage alarm.

- **Down Force Low Voltage** alarm indicates when power is lost to a specific row valve or Row Control Module (RCM).
- **Low Voltage** alarm appears when the generator is not outputting power or the breaker is off.

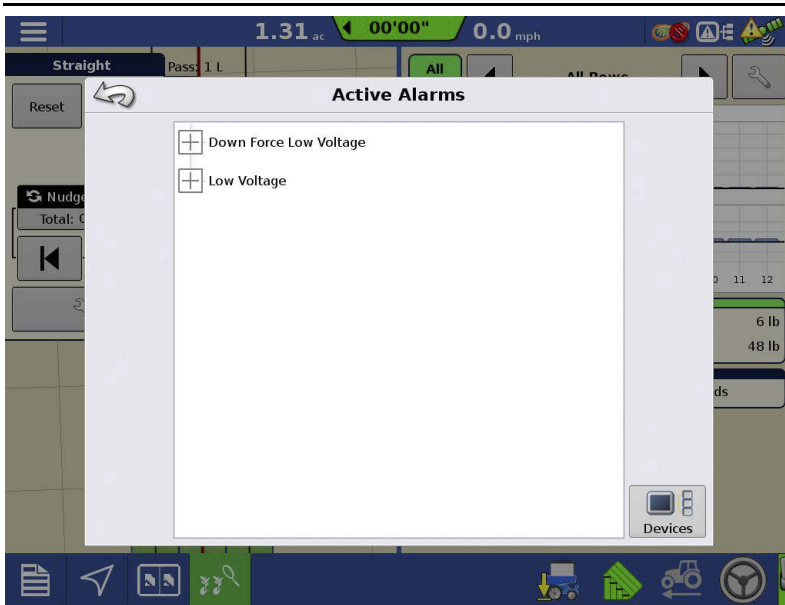

Presence of either alarm indicates an issue with system performance.

## Issue

- If power is lost, the down force system will enter a non-active state.
- When power to the row valve is lost, the Down Force Low Voltage alarm will appear on the display roughly 10 seconds later.
- When the RCM loses power, the Down Force Low Voltage alarm will appear immediately.

With either scenario, when power is restored, the alarm will remain in the active alarms list and down force will still be in a hold state.



**NOTE!:** When the planter is up and a row valve loses power, there is a 5 second delay before the alarm appears on screen.

## Resolution

When power is restored, the down force system will remain in a hold state. To return to an active state, press the Down Force Status Button twice. The first click will place the system into a paused state.



---

The second click will return the system to active control.



### **Low Gauge Wheel Load**

Down force system does not achieve acceptable gauge wheel load

User defined alarm to signal operator if planter is losing planting depth.

### **Hydraulic Pressure too low**

Down force system commanding more down force but hydraulics are not reacting

#### **Recommendations:**

- Check tractor remote is on
- Check that enough hydraulic fluid is directed to down force system

### **Pressure Sensor Failure**

**Problem**—Pressure sensor is outside voltage range.

**Resolution**—Disable the pressure sensor to eliminate alarm until it can be replaced.

### **Gauge wheel sensor types do not match. Please reconfigure.**

- The Gauge Wheel Sensor selection in the Down Force settings General tab, does not match the sensor type installed on the planter.
- One or more Row Control Modules are not detecting the gauge wheel sensor.
- One or more Row Control Modules have an incorrectly set gauge wheel sensor type.



#### **Recommendations:**

- Verify type or part number of the gauge wheel sensor installed matches the Gauge Wheel Sensor setting
- Verify all sensors are plugged in.
- Inspect cabling and connections on Row Control Module I/O cable.
- Set Gauge Wheel Sensor to a different type, accept this type by pressing the green check mark and returning to the map screen. Re-enter Down Force settings and change the Gauge Wheel Sensor back to the correct type.



**ATTENTION!:** If Gauge Wheel Sensor are not installed on every row, be sure to enter the Down Force settings Advanced tab and Disable the Load Pin on all rows that do not have a sensor.

## Planter Row Control Module Indexing Errors: Found # of #

**Problem**—When attempting to load an Event, the Configuration Selection screen displays a  next to the configuration name. There is a  next to Planter Row Control Modules (RCM). Not all RCM's have been detected.

### Resolution:

- Verify that the second number matches the number of planter rows.
- Next inspect the installation of the RCM's and the cabling Local CAN BUS.
- Verify all 3 lights on each RCM are green. LED #2 will be OFF if SureDrive® is not configured.
- Inspect Local CAN terminators.

For Indexing Error Screens, see [Planter Row Control Module-Indexing Error Screens on page 577](#).

## FAQ

-What should be input hydraulic pressure (PSI) be set at?

2500 to 3000 PSI (with the vehicle hydraulic source set to max flow)

-Where do I plug in an implement switch(s)?

Into the Implement Switch Module(s).

-What if I don't have any free SCV connections for the down force valve?

Teeing into existing lines is acceptable. Do not tee into the vacuum fan line if adjusting fan RPM on the tractor with a knob or dial. Teeing into the line before a flow limiter on the planter would be acceptable. Teeing into the hydraulic drive supply line would be the best option. Do not tee into Rawson Drive supply line.

-Why does the system need 3 hydraulic lines (Pressure, Return and Tank)

Under normal operation, pressure in the down force system is increased through the Pressure line and relieved through the Return line. When the planter runs over a terrace or

---

a water way, the excess pressure is released through the Tank line. All three lines MUST be connected.

-What is a CAN Repeater Module; and when is it required?

A CAN Repeater Module is a component that is used on Ag Leaders Individual Row Hydraulic Down Force and SureDrive systems. It is only installed on systems with a Local CANBUS that exceeds a certain length. The modules purpose is to “repeat” CAN messages on these longer BUS lines to ensure communication between all of the modules connected. Ag Leader will supply the CAN Repeater Module in appropriate kits as needed.

-Can an open-center tractor be used for Ag Leaders Hydraulic Down Force?

Open-center tractors are not recommended for use with Ag Leaders Hydraulic Down Force.



---

## Troubleshooting

**Problem**—Down Force will not adjust in Auto Control while planting (Down Force Holds)

- Down Force indicator arrow stays Yellow while planting.

**Solution:**

- Verify implement switch(s) polarity is correct.
  - Verify implement switch(s) are tripping when planter is lowered.
1. With planter lowered, verify implement switch(s) have tripped.
  2. Check the polarity of the implement switch is correct. Implement switches can be swapped from Normally Open to Normally Closed by switching 3-pin weatherpack connections.
  3. On the implement switch module, verify the indicator light turns blue on the module when the switch is tripped to the planting position.
  4. Check mounting of implement switch(s).
  5. While operating Down Force, verify the toolbar is not lifting causing the implement switch to trip.

**Problem**—Supplemental Force and Gauge Wheel Load do not appear to reflect each others responses. (Ex: High Gauge Wheel Load on Row 1, with very little Supplemental Force being applied, or vice versa)

**Solution**—Verify installation of the Local CAN terminators.

1. The Local CAN is the communication wiring bus that transfers the gauge wheel load readings to the main control module. There needs to be a terminator on each end of this bus.
2. Terminator PN 4002870 will need to be installed on the wiring harness closest to row 1. Terminator 4002871 will need to be installed on the wiring harness closest to the end of the planter (right-hand side when looking at planter from the rear)

## Implement Switch Adjustment Problems

**Problem A**—Down Force is too high at the beginning of a pass after the planter has been raised.

This problem can be caused by the implement switch tripping too late when the planter is being raised. If a row with a gauge wheel sensor comes off the ground before the implement

---

switch trips, there is the chance the sensor will register no gauge wheel load and the system will react to it and apply down force. Once the switch trips, this higher down force is now held. When the planter resumes, down force may be initially excessive until it can relieve pressure.

**Solution**—Verify that InCommand™ display firmware is version 3.0 or higher and RCM firmware is version 1.5 or higher. Adjust the implement switch mounting so that it trips sooner when raising the planter. This will allow the system to hold the appropriate amount of down force.

**Problem B**—Low gauge wheel load is witnessed on a row causing the system to apply Max down force; but after inspection of the seed trench, the problem row appears to be receiving adequate gauge wheel load.

This problem can be caused by the implement switch tripping too late when the planter is being lowered. (Ex: 50 lbs of actual load may be displayed as 0 lbs). The down force system will detect the “lower gauge wheel load” and react to it by applying more down force until the sensor reaches an acceptable load.

**Solution**—Verify that InCommand™ display firmware is version 3.0 or higher and RCM firmware is version 1.5 or higher. Raise the planter to allow the sensors to re-zero with no load on the gauge wheels. Adjust the implement switch so that it trips sooner when lowering the planter. This will prevent the false gauge wheel load readings.

## Module Diagnostic Lights

### Planter Control Module (PCM)



Φ **High Power** – Indicates ECU power (12V) to the module.

Status	Definition
OFF	No Power
Blinking Yellow	Firmware Upgrading
Solid Green	High Power OK

1. Local CAN – Indicates if the PCM is communicating with the RCM's.

2. Display CAN – Indicates if the PCM is communicating with the controlling display.

Status	Definition
OFF	No CAN Communication
Solid Red	CAN BUS Off
Solid/Blinking Yellow	CAN BUS Error
Blinking Green	CAN BUS Communicating

## Row Control Module (RCM)

Φ **High Power** – Indicates high power (12V) to the module.

Status	Definition
OFF	No Power
Blinking Red	RCM Indexing
Solid Red	Low Voltage
Solid Green	High Power OK

1. Local CAN – Indicates if the RCM is communicating with the PCM.

2. Display CAN – Indicates if the RCM is communicating with the Motor Driver.



**NOTE!:** LED #2 will be Solid Yellow if SureDrives are not configured.

Status	Definition
OFF	No CAN Communication
Solid Red	CAN BUS Off
Blinking Yellow	CAN BUS Error
Blinking Green	CAN BUS Communicating

## Implement Switch Module



### Left LED

Status	Definition
OFF	No CAN Communication
Solid Red	CAN BUS Off
Solid/Blinking Yellow	CAN BUS Error
Blinking Green	CAN BUS Communicating

### Right LED

Status	Definition
OFF	Planter Raised
Solid Blue	Planter Lowered

## Implement Switch Status Indicator

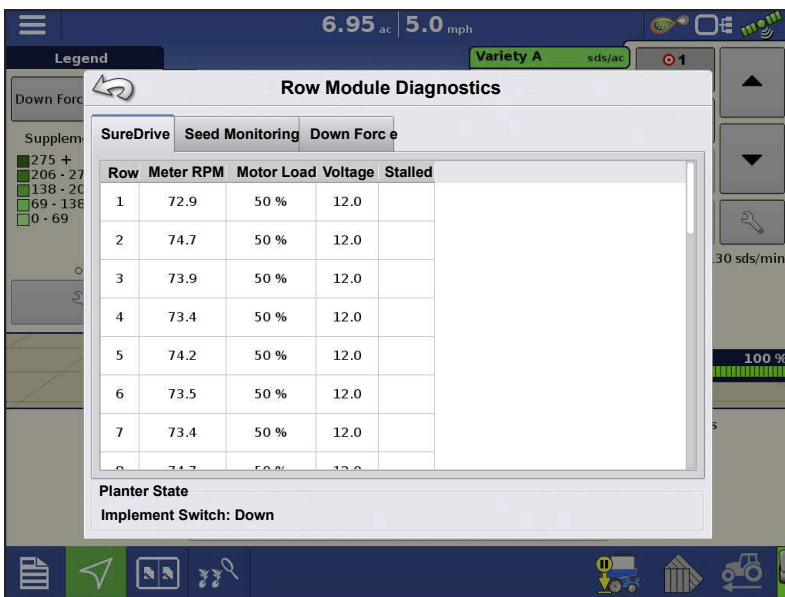

Highlight a Row Control Module in the CAN B tab and press the Diagnostics button in the lower right-hand corner to view the implement switch status.

## Planter Row Control Module-Indexing Error Screens



Image 1 - The message that will appear when all modules have been detected on the CAN bus but there is an indexing issue.



There are more modules on the CAN bus than what the configuration requires.



There is an actual Split Row Mismatch due to a bad jumper in one of the interplant row modules.



Image 4 - How the Field Select Wizard should appear when all RCM modules have been found on the CAN Bus, properly indexed, and properly assigned to each of the rows.







DirectCommand™ allows the variable rate application of single or multiple liquid products. Once a configuration has been completed, the Map View screen appears.

## Load Configuration



Press the Application App from the home screen to load a configuration.

## Map View

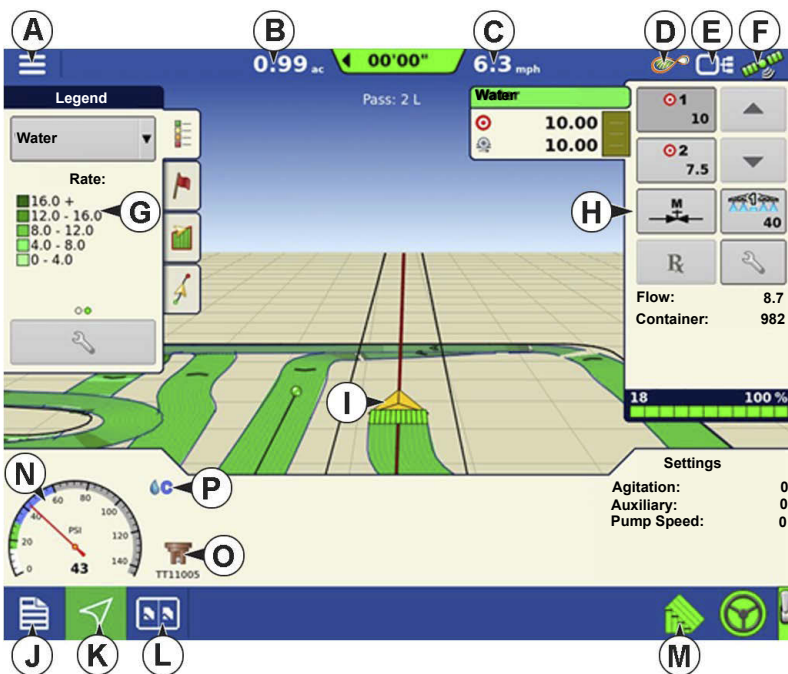

- A.Menu button
- B.Total Logged Field Area
- C.Ground Speed
- D.AgFiniti® Status
- E.Diagnostics
- F.GPS Signal Indicator
- G.Display Legend
- H.Product Control toolbox
- I.Vehicle Icon
- J.Event Summary
- K.Map View
- L.Split screen
- M.AutoSwath™
- N.Pressure Diagnostics



**NOTE!:** Pressing the Map View button will cycle between the available Map screen views, and the appearance of the Map View button changes.

# Product Control Toolbox

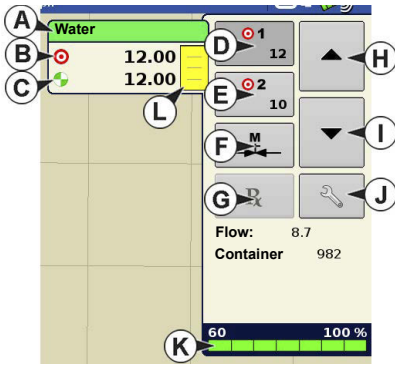

During DirectCommand Run Time operations, the Product Tabs are shown in the upper right-hand side of the Map screen. Press the Product Tabs, and an extended view shows the Rate buttons, Manual Valve Control button, Prescription button, Rate Increase and Rate Decrease arrows, and the Rate Setup button, all of which are described below.

- A. Product
- B. Target Rate
- C. Actual Rate
- D. Rate 1 button
- E. Rate 2 button
- F. Manual Valve Control
- G. Prescription button
- H. Rate Increase arrow
- I. Rate Decrease arrow
- J. Rate Setup button
- K. Section Status Indicator
- L. Container Level

**Target Rate**—The Target Rate is desired application rate.



**NOTE!** In some conditions, the Target Rate may increment more quickly than the Actual Rate.

**Actual Rate**—The Flow Sensor returns the actual rate being applied.



**NOTE!** In some conditions, the Actual Rate may increment slower than the Target Rate, or its numeric values may vary before matching the Target Rate.

**Container Level**—The Container Level shows the amount of product in the container.

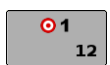

**Rate 1 and Rate 2 buttons**—The Rate 1 and Rate 2 settings represent preset application rates that allow operators to quickly change between desired target rates for each individual product.



**Manual Valve Control button** — The Manual Valve Control button allows operators to specify the position of the control valve. Operators use this option to prime the system before application or clean out the equipment at the end of the day.

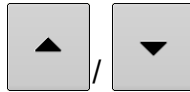

**Rate Increase and Decrease Arrows** — allow Product Application Rate to be changed according to the Target Rate Increment. In using manual valve control, the increase and decrease buttons allow the position of the control valve to be defined by the operator.

**Prescription button**— 

**Rate Setup button**— 

## Rate Control Settings



Adjust the Rate 1 and Rate 2 settings shown at the Product Control Toolbox on the Map screen, as well as import application product prescriptions. To access the Rate Control Settings screen, press the Rate Setup button on the Product Control Toolbox. The Rate Control Settings screen appears.

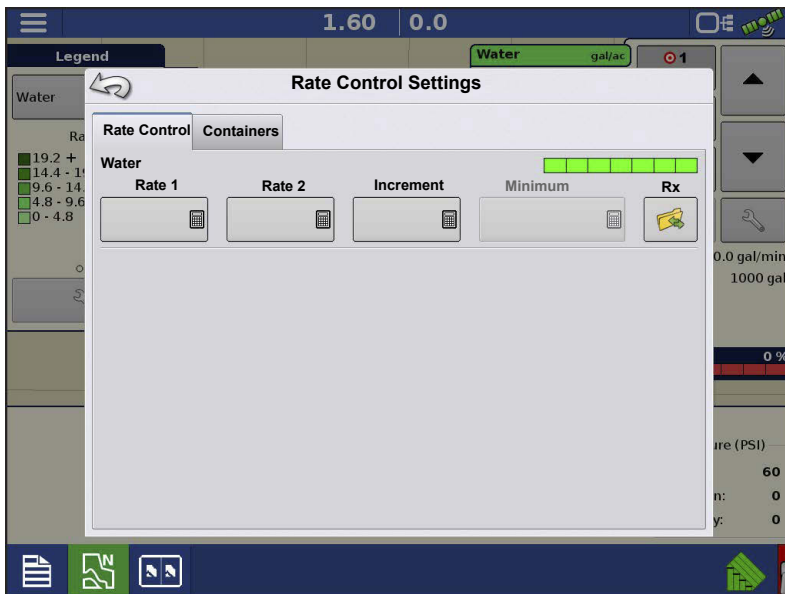

**Rate 1 and Rate 2** — The Rate 1 and Rate 2 settings represent preset application rates that allow operators to quickly change between desired target rates for each individual product. Press  to enter the desired amount.

**Increment** — The Increment button allows operators to specify the increase or decrease amounts for a

specified rate by using  on the Product Control Toolbox. Press  to enter the desired increment.

**Prescription** — To load a map-based prescription file, press the Prescription button.

Refer to [Loading Prescriptions on page 586](#) for further detail.

**Minimum Flow** — (Used for DirectCommand Liquid Applications only). This setting is used to maintain a consistent spray pattern. The display will not allow flow to drop below the entered setting. Set to flow at the lowest operating pressure for the selected spray tips with all sections on. When spraying with one or more boom sections off, the system automatically reduces the Minimum Flow setting according to the reduced spray width. To adjust this setting, press  and enter the desired numeric value.

## Container Level Settings

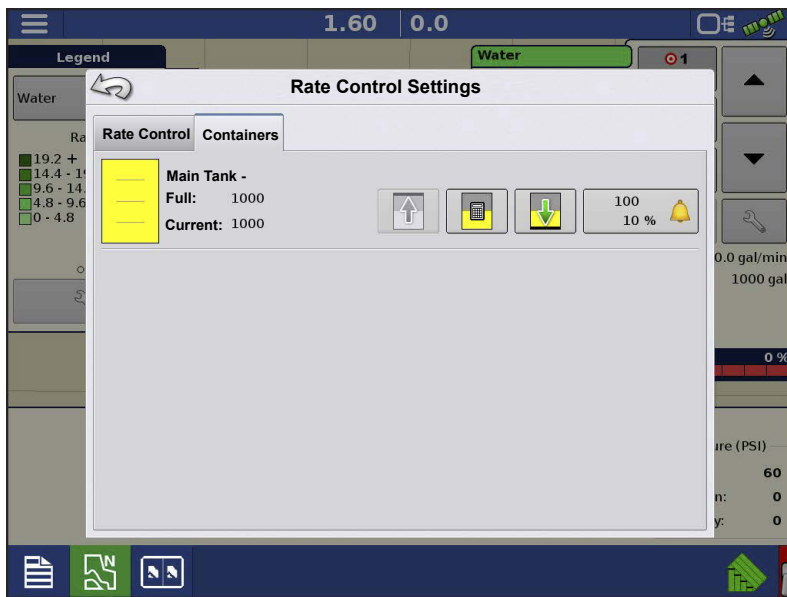

When filling or emptying container, use the Container Level portion of the Rate Control Settings screen to update the amount of product in the containers.

Container Level screen

 **Tank Fill** — The Tank Fill button increases the container level logged in the display to the user-defined maximum volume (specified in the Container Setup Wizard).

 **Tank Empty** — The Tank Empty button decreases the container level logged in the display to zero.

 **Tank Partial Fill** — The Tank Partial Fill button increases the container level logged in the display to specific amount specify by pressing calculator icon. Pressing the Partial Fill button summons the Adjust Container Amount screen.

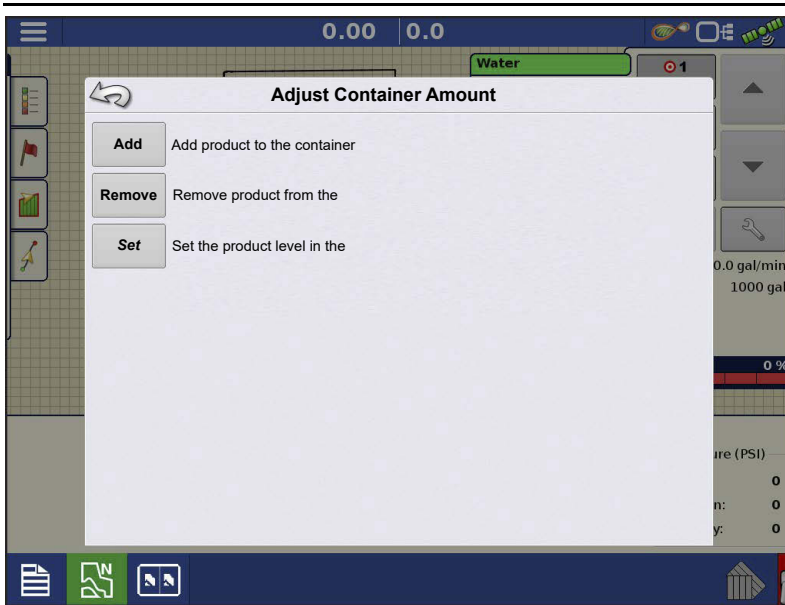

## Adjust Container Amount

- **Add** — Adds product to the container.
- **Remove** — Removes product from the container.
- **Set** — Sets the product level in the container.

## Tank Alarms

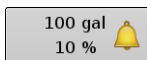

The Container Alarm button, which appears on the right of the Container Level portion of the Rate screen, displays the capacity of the tank as well as the percentage at which the Low Container Level warning will sound. To adjust these settings, press the button and the Container Alarm screen appears.



Adjust container level warnings using the following buttons on the right-hand side of the Container Alarm screen.

The **percentage (%)** button sets the warning threshold according to the percentage of solution left in the tank. In the example above, the threshold is set at 10 percent.

The **units of measurement** icon sets the warning threshold according to the amount of solution left in the tank. This

icon is named according to the container's units of measurement specified during the Controller configuration procedure.

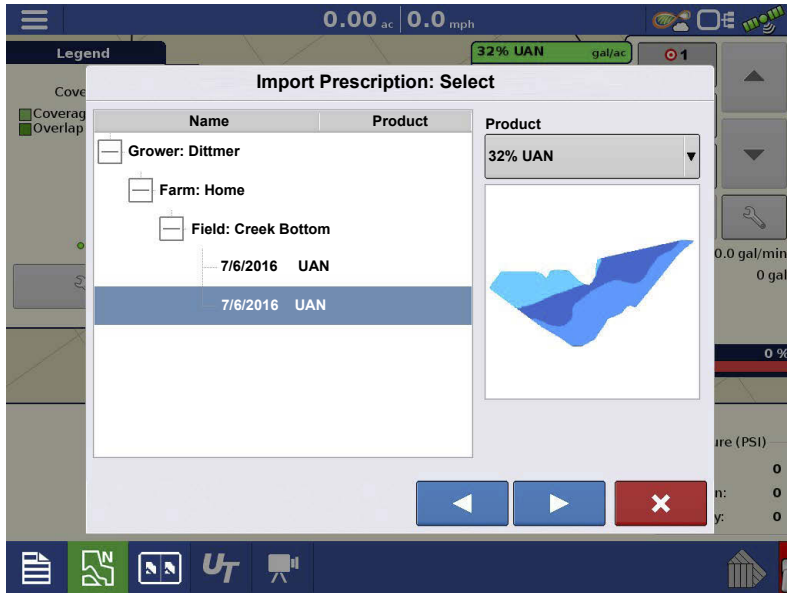

The **Disable Low Container Level** button, which appears as a bell with a red slash across it, disables the Low Container Level warning.

## Loading Prescriptions



1.  Press the Rate Setup button on the Product Control Toolbox.

2. Press the Load Prescription button.

3.  Using an inserted USB or AgFiniti Cloud, search for and highlight the correct .agsetup, .irx, or shape file and press .

4. Select the prescription in the Select Prescription screen, and select the correct controlling product from the Product dropdown box. A preview prescription map is displayed. Press .



5. In the Modify Prescription Screen the prescription scale, minimum to apply, and maximum to apply can be changed. As the three parameters are changed, the adjusted total to apply and average rate will update accordingly.

6. Press the .

7. After returning to the Mapping Screen, the prescription will appear on the map while in a North Oriented view.

## Shape File Conversion

What is commonly called a shape file is actually a collection of three different files. All three of the files are required and must be present on the USB drive for the system to use shape file groups for variable rate product application. A single "shape file" can contain recommendation rates for multiple products.



1. To begin, press the Rate Setup button on the Product Control Toolbox.

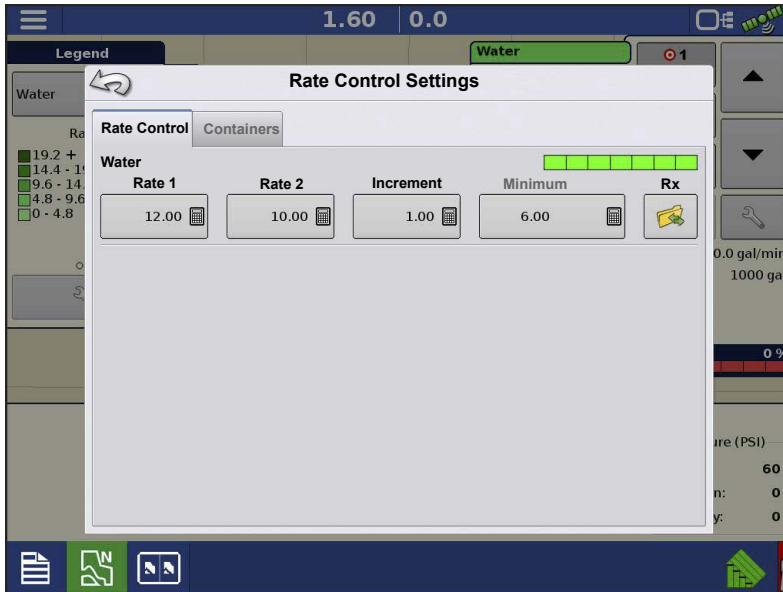

The Rate Control Settings screen appears

2. Press the Load Prescription button.

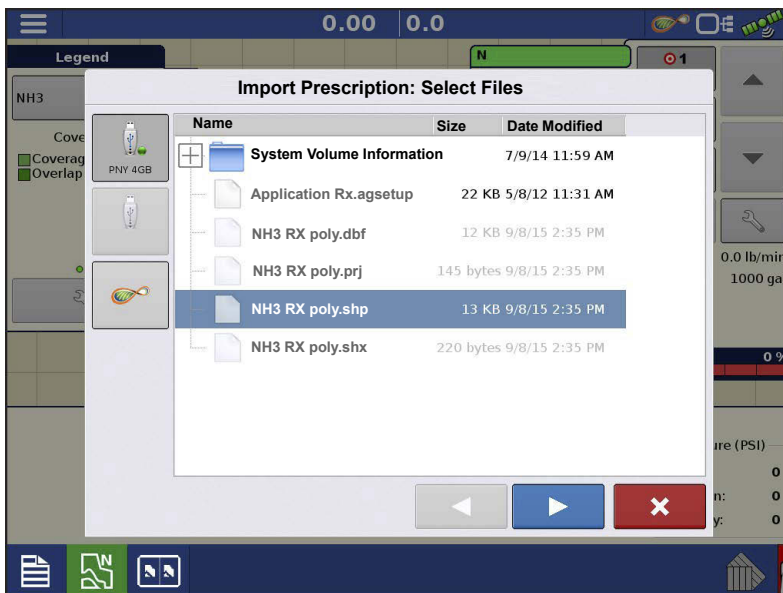

3. The Select File screen appears.

Highlight desired .shp file and press



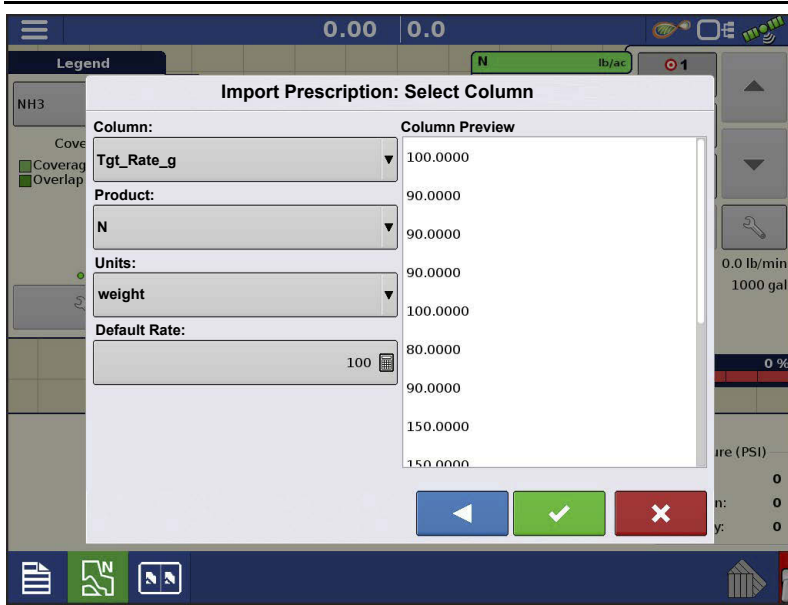

**4. Select Column From Shape File**—

Select the column that contains the product recommendation rate. The list on the right side of the dialog shows sample data from the selected column.

**5. Select Units**—Select the controlling units for product application.

**6. Default Rate Setting**—The system assigns a default rate. Use the on-screen keypad to edit the value if desired.

**NOTE!** Select the product and units that the shape file prescription was made for. Selection of the wrong data column or unit will result in misapplication of product.

**ATTENTION!** The only time the default rate is used by the system during product application is if the Rate Outside of Field selection is set to "Rx default". This setting is located in the Equipment Settings portion of configuration setup. If the Rate Outside of Field selection is set to "Rx default", the default target rate will be used when the vehicle exits the area covered in the prescription map.

## Creating Products

Creating application products and product templates can be completed during initial setup or from the Product Selection screen of the Field Operation Wizard when starting a field operation.

### Creating Single Products

To create a single product, to be added to a product template or to be applied by itself, use the on-screen wizard described in the following steps.





Select:

1. Product Type
2. Product Units
3. EPA Product Number (Optional)

Check box if product is a Restricted Use Pesticide.

4. Manufacturer name if applicable.

Manufacturer name can be added to the drop-down menu by pressing



5. Press  to enter a unique name for the product.

Created product should appear under the Application heading located on the Product tab of the Configuration Setup screen.



**NOTE!:** Some Fertilizer and Carrier product types are predetermined in the display. These product names cannot be edited. Their Manufacturer and EPA Numbers can be edited after the product is created. Examples are: Fertilizer>DAP or Carrier>30% UAN.

## Creating Product Template

Product Templates are set up by using the on-screen wizard.



**NOTE!:** Prior to making a new product template, it is recommended to add the individual products to the list in the units recommended by the chemical label.

It is recommended to create product templates that contain the products applied for a crop type or time of the season.

Examples are:

- Pre-Emerge Burndown
- Post-Emerge Corn
- Post-Emerge Beans
- Insecticide
- Fungicide

In each template the products can be checked on/off for the mix when loaded at the run screen.



### 1. Select Tank Mix

#### Define By

- Total amounts - mix/blend defined by amounts added to the tank (total of each product in tank)
- Rate/acre - mix/blend defined by the amounts applied per acre (rate of each product applied/area)

### 2. Enter a Base Amount or Base Rate and Units.

- Total Amounts - Tank/Bin Size
- Rate/Acre - For Rate Applied per Acre

### 3. Select Carrier



- Press  to create a new carrier.

### 4. Press by the Add Mix/Blend Contents box to start the process of adding components to the mix.

### 5. Select the desired component from the drop-down menu.



**NOTE!:** More than 7 products can be part of a template, but only 7 or fewer can be active at the same time.

- A new product can be set up at this time by pressing  and following the Product Setup Wizard.
- Press  to add selected product, or press  to return to Add Mix/Blend screen without adding a product.



### 6. Press to add an additional product.

### 7. When all components have been added press .

### 8. Enter Manufacturer name is applicable.

- Manufacturer name can be added to the drop-down menu by pressing .

9. Press  to enter a unique name for the mix/blend.

- Press  to complete the process of setting up the mix/blend, or press  to return to the Configuration Setup screen without adding a mix.

The product mix/blend appears under the Application heading located on the Product tab of the Configuration Setup screen.



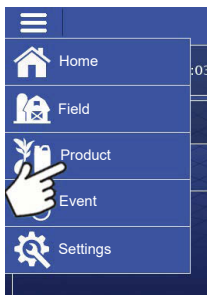

Represents Product Templates

## Configure Product Mix

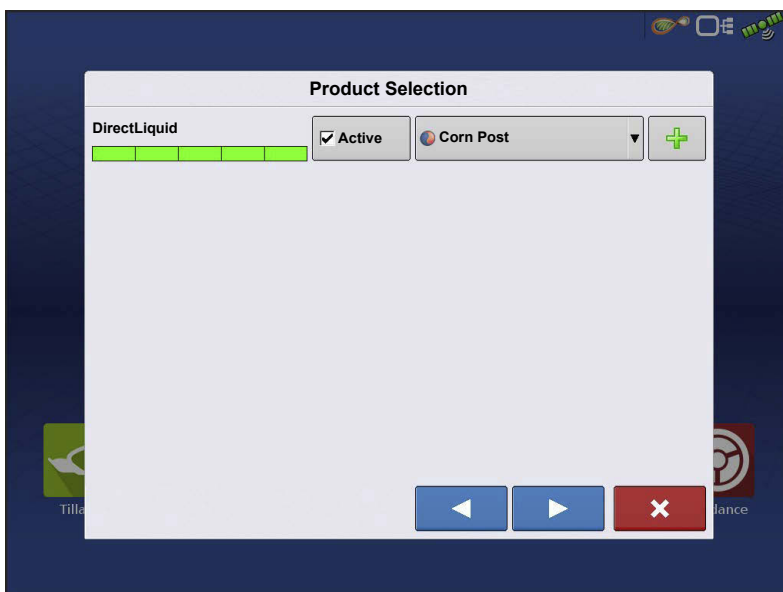

When using a product template, the mix contents and amounts are defined in the Configure Product Mix screen available in the Event Setup Wizard, or Product button in the main menu.



1. Select mix/blend from the drop-down list or press  to create and new mix/blend.

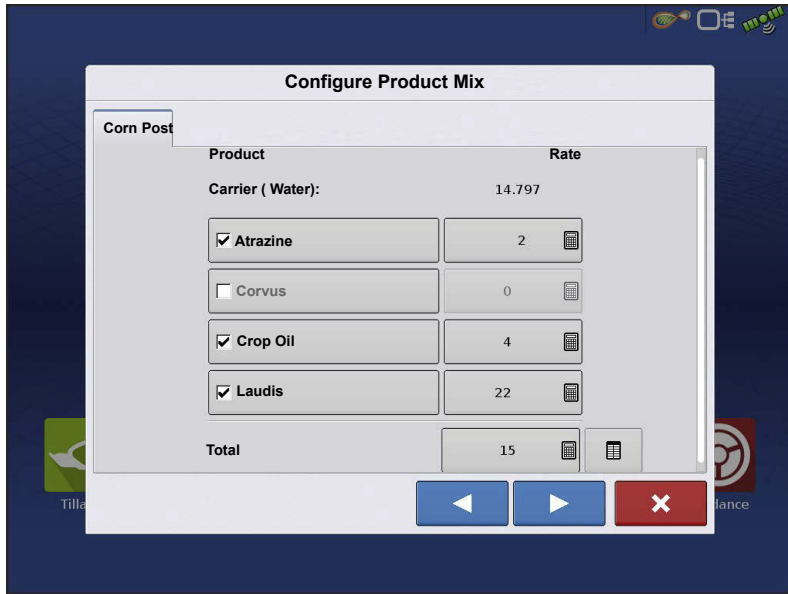

2. The product template mix contents and amounts are defined by:

- a. activating or de-activating products
  - b. changing rate or total amount of product
  - c. changing total amount of the product or overall rate of product application
- A product can not be active with a rate

of zero. Press  to access the Mix Calculator.

3. When a product template is setup using rate/area, the Mix Calculator can be used to show how much of each product to put in the tank when the user enters the desired amount to fill.

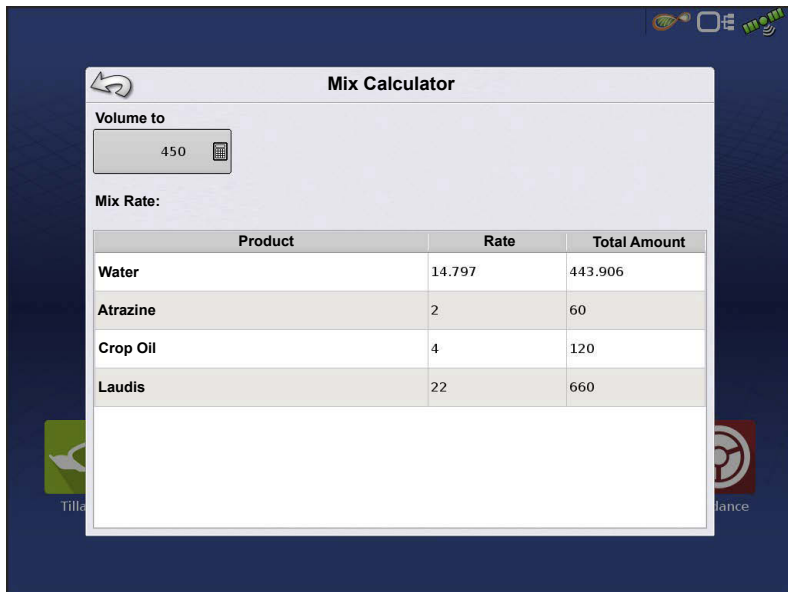

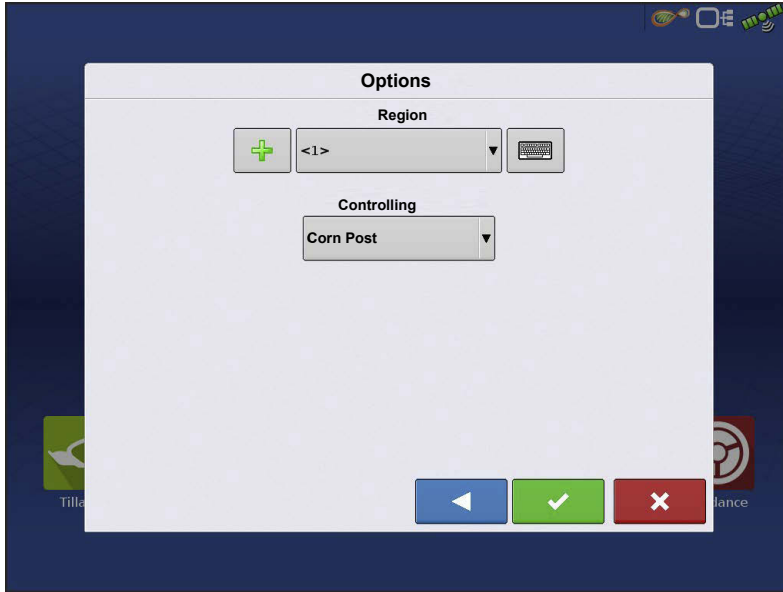

4. Press the Volume to Calculate button and input the total volume.

Table will give the user the amount of each product to put in the tank.



5. Select Region from the drop-down menu or press  to name Region

Verify the Controlling Product for the Mix/Blend.

Press  to load the Event to the Map Screen, or press  to return to Home screen without setting up an Event.

## Create Configuration

A wizard will step through the process of selecting or creating a configuration with application settings.

The configuration can be started in two places:



OR

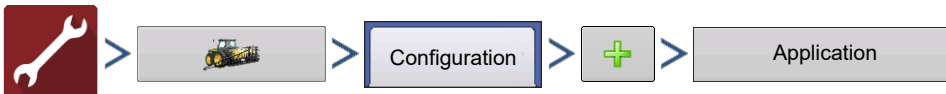

Operating Configuration will be viewable when starting a new Field Operation with the Application Wizard.

**Manage Equipment** button can also be used to create or edit specific vehicles and implements.

# Implement Offsets

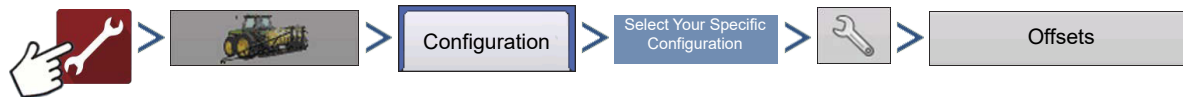

OR

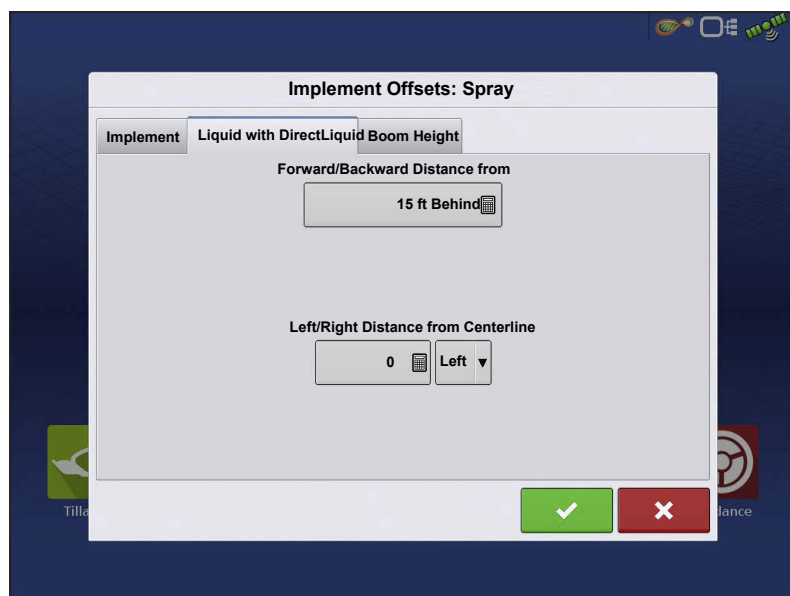

Implement Offsets screen appears, with each channel's settings shown on its own tab.

Defaults to the value entered during Configuration Wizard

Boom sections can independently be offset forward or back (Application Operation Only)

1. Press  to access Swath Section Offsets screen.

# Liquid Rate Control

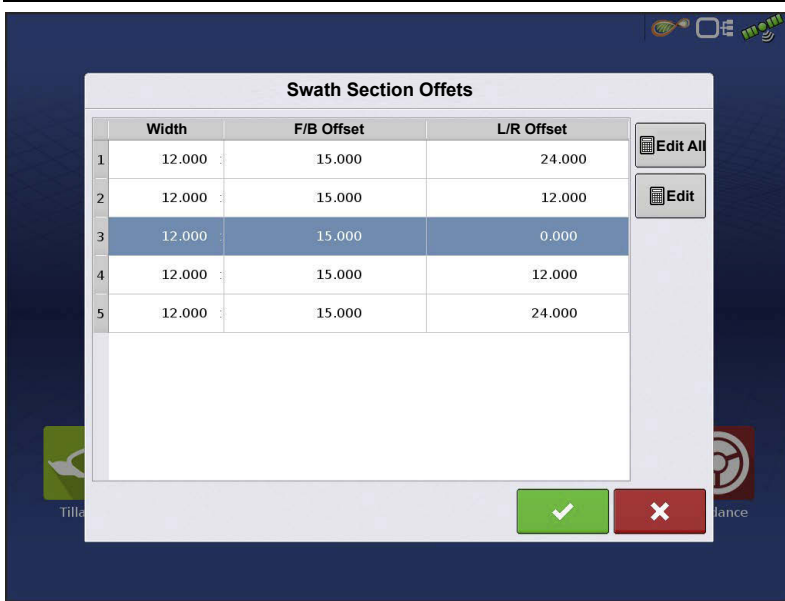

2. Select Swath section to edit and press Edit button.
  3. Enter Offset for that specific section and Forward/Backward from rear axle.
  4. Press  to enter change.
- Setup will indicate which offset is entered

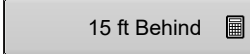
 **Global**—All sections have the same offset.

 **Individual**—At least one section has a different offset.

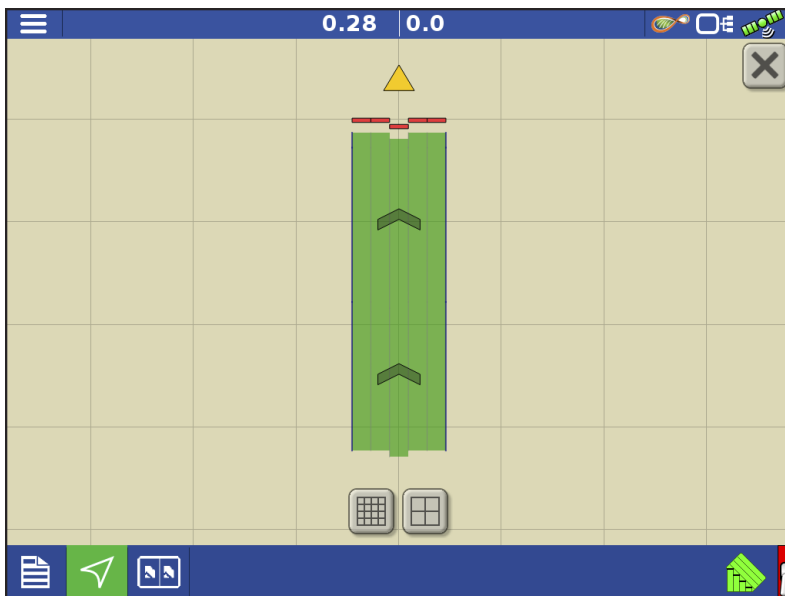

Runscreen reflects section offsets

# Equipment Settings

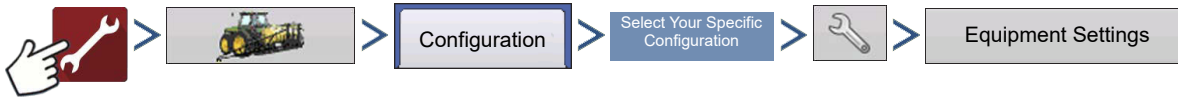

OR

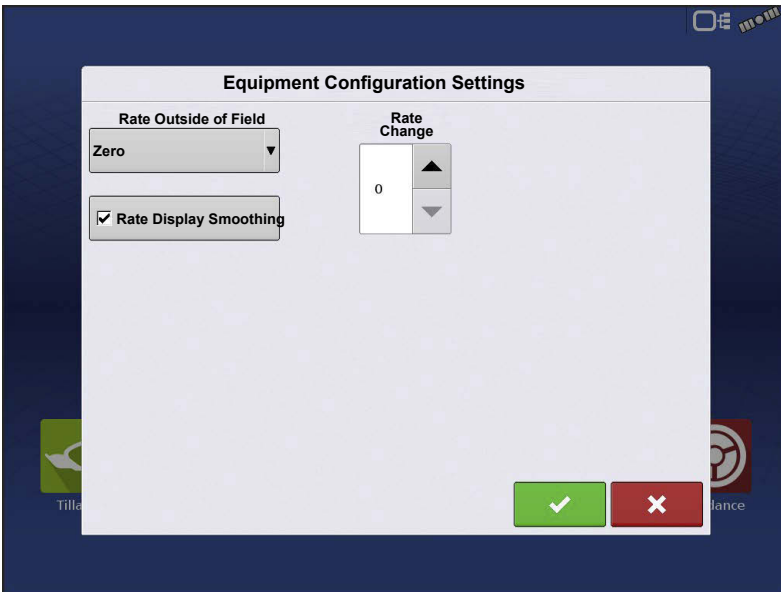

**Rate Outside of Field**—This setting will define how product will be controlled when leaving a field boundary.

- **Zero**—This will stop application.
- **Last Good**—This will continue application at the last known rate.
- **Rx Default**—When using a prescription, this will apply at the Default Rate (or outside of boundary

rate) as defined by the prescription file.

**Rate Display Smoothing**—Determines how the feedback from the control channel rate sensor will be displayed on the map screen. When de-selected, the system will display raw feedback from the rate sensor. When checked, the system will display target rate when the application rate is within 10% of the target rate setting.

**Rate Change Look-Ahead**—This setting compensates for any latency in the control system when changing between different product flow rates during variable rate application. The typical setting range for this is 0-1 seconds. This setting can be thought of as a “look ahead” value when using a variable rate prescription. The display will send the signal to change rates before hitting a transition line so that the applied rate is correct when crossing into the new management zone.



## Auxiliary Input

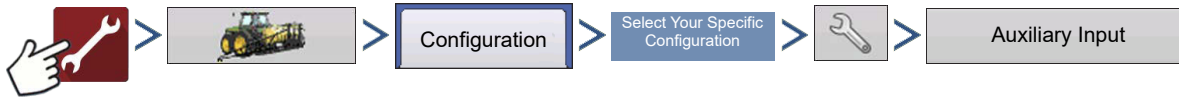

OR

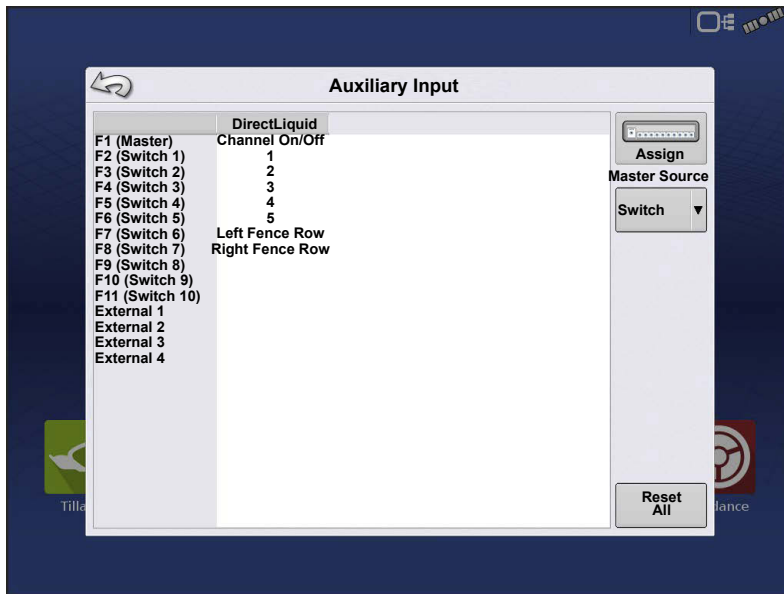



DirectCommand applications default boom sections to the switchbox in order, starting with switch 1. From the Auxiliary Input screen, the operator can customize the switches to the boom sections, if desired; or assign left/right fence row nozzles.

1. Press 

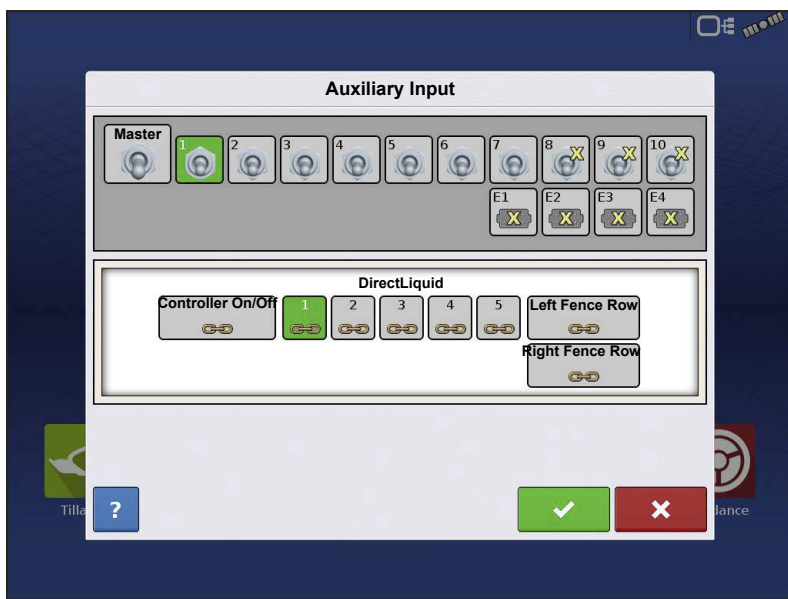
2. Highlight the desired switch to assign a function to it.



3. Select appropriate function(s) (boom sections for this operation) to assign to the desired switch. Chain icons within each function will "link" once pressed to indicate they are assigned. If a function has a "broken link" then it is not assigned. If a switch has a "X" then it is not assigned to a function. Press the  to save the setup.

 **NOTE!:** Even if no specific functions are assigned to the Master switch, the Master switch will still serve as the total system on/off switch.

=

## Fence Row Nozzle Indicators

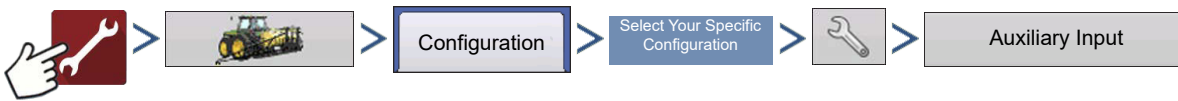

Control fence row nozzles through the DirectCommand system by mapping the switches in Auxiliary Input Settings. Fence row nozzles can be mapped to any switch. After specifying Fence Row Nozzle settings at the Auxiliary Input Assignment screen, the **Fence Row Nozzle Indicators (A)**, which are shaped like triangles, appear on either side of the sections behind the vehicle

icon.

**i** **NOTE!** If a switch is selected as a Left or Right Fence Row Nozzle, the system sends power out of Boom Pin 11 for the left fence row, and Boom Pin 12 for the right fence row.

**i** **NOTE!** The boom sections next to the fence row nozzles must be turned on before the fence row nozzle can be turned on.

## Hardi Safe Track

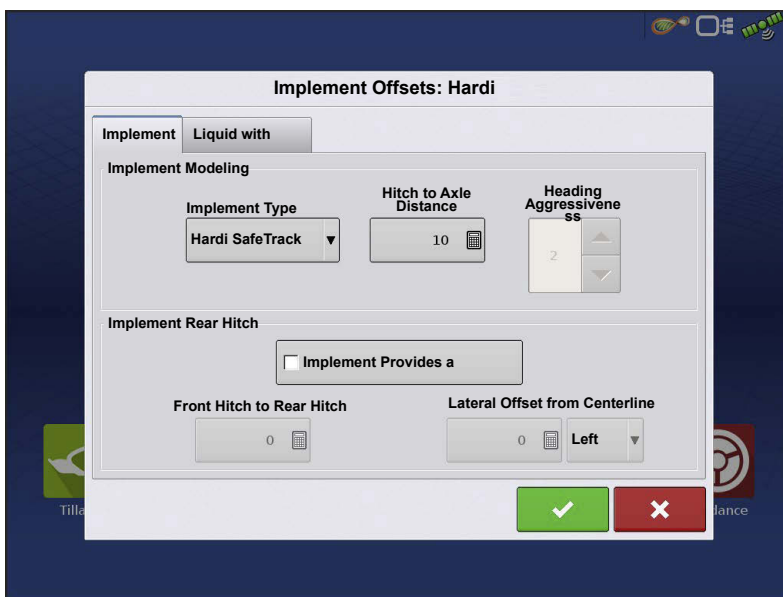

When using Hardi ISOBUS, Implement Modeling can be set to Hardi SafeTrack. This allows display to accurately calculate path of sprayer. Hardi SafeTrack Modeling is utilized by the display when SafeTrack is engaged on the machine.

**i** **NOTE!** When a Hardi ECU is present and SafeTrack is in use, the Heading Aggressiveness will be

grayed out in the Implement Offsets screen. The Heading Aggressiveness will need to be adjusted from the Hardi interface.

If a trailed implement utilizes a steerable axle, the Hardi SafeTrack feature can be used without a Hardi ECU. This will allow manual adjustment of the Heading Aggressiveness from the Implement Offsets screen.

- **Heading Aggressiveness**

The Heading Aggressiveness setting can be used to fine tune mapping of a trailed implement. (Example: Pull type sprayer that has a steerable axle feature) The setting ranges from 0 - 10. The default value is 2.

An aggressiveness setting near 0 or 1 will model similar to an implement that has a rigid axle. With the only pivot point being the implement's attachment at the vehicle's hitch.

As the aggressiveness setting is increased, the modeling will start to resemble an implement that "follows" the path of the vehicle. The modeling will become more exaggerated the closer the setting is to 9 or 10.

## Liquid Application Controller Settings

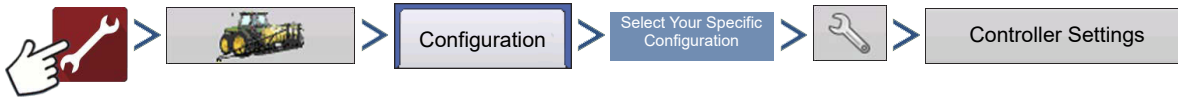

OR

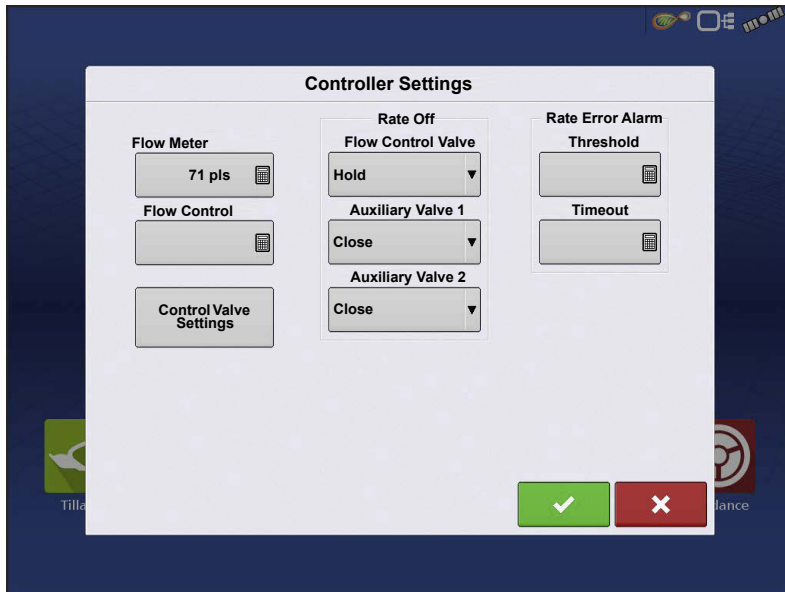
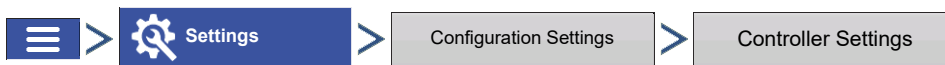

Make the following adjustments:

### Flow Meter Calibration —

Calibration value representing the number of pulses that equal one-gallon of product flow through the controlling system. This value can typically be found on the flow meter tag. (For Raven flow meters, divide this value by 10 before editing it in the display.)

### Flow Control Delay —

Setting that specifies a period of time from master switch on and the start of product application to the first flow control correction. This setting can be used to eliminate unwanted correction of flow control at the start of each pass. Typical setting values are 1 –2 seconds for liquid application control.

**Control Valve Settings** — Opens the Control Valve Settings screen, which displays control valve settings for PWM, Servo, Calibrated Reflow and Ramsey Valve Controls.

### Rate Off

**Flow Control Valve**—When set to "Close," the controlling system shuts down when there is either a zero rate in the field or when entering an already-applied area. When set to "Hold," the controlling system remains in the last known state when all sections are shut off.



**NOTE!** If a PWM is the controlling system and the Flow Control Valve setting is set to "Hold," the valve will adjust to PWM Standby when all sections are shut off.

**Auxiliary Valve 1 & 2** —When all boom sections are off, this setting closes or opens an auxiliary valve. Choose settings for up to two auxiliary valves.

**Allowable Error** —Determines the percent of error that is allowed prior to the product control system making any flow rate changes (found in the "Control Valve Settings" screen).

Default value for this setting is 2%. The normal dead band setting range is 2% - 3%.

- Too low of a setting value can cause the product control system to continually hunt for the target application rate.
- Too high of a setting will cause excessive product application error.

**Threshold** —The user-defined percentage of actual rate error allowed before an alarm sounds.

**Timeout** —The number of seconds that an actual rate falls out of the error threshold before an alarm sounds.

## Control Valve Settings - PWM

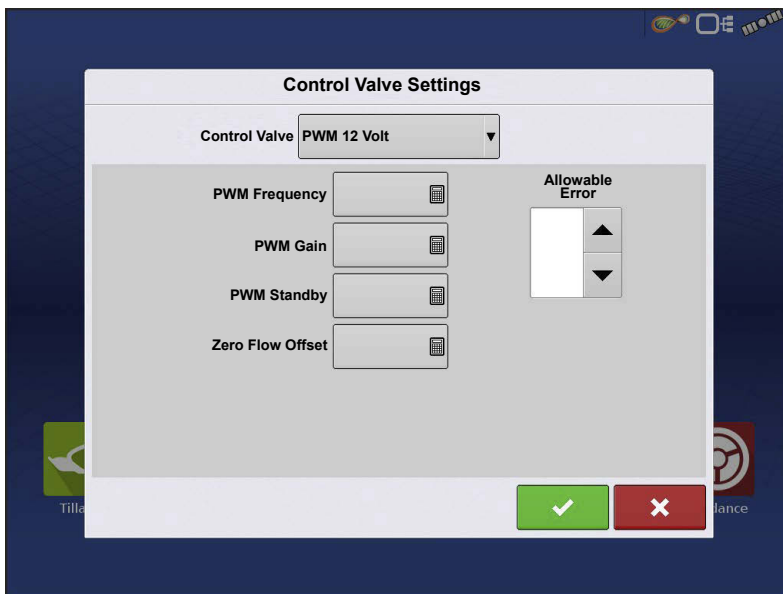

**PWM Frequency** — The frequency that the PWM control valve is pulsed at. Settings can be found from the manufacturer of the valve. Default Value is 100. Typical settings range from 100-125 Hz.



**NOTE!** See PWM valve manufacturer information for recommended settings.

---

**PWM Gain** — Determines how aggressively the control valve responds when making rate change adjustments. The higher the value the more aggressive the system response is. Default Value is 800.

**Zero Flow Offset** — Represents the maximum duty cycle that is sent to the control valve without producing any hydraulic flow from the PWM valve. Using too high of a Zero Flow Offset value can cause the product control system to not properly control low rates or shut off. Default Value is 30. See the PWM valve manufacturer information for recommended settings.

**PWM Standby** — This is a user-defined setting that determines the percent duty cycle the system uses when the boom sections are all off. The setting must be greater than the Zero Flow Offset.

 **NOTE!** The current PWM Duty Cycle can be viewed at the Liquid Diagnostics screen.

## Control Valve Settings - Servo, Calibrated Reflow and Ramsey Valve

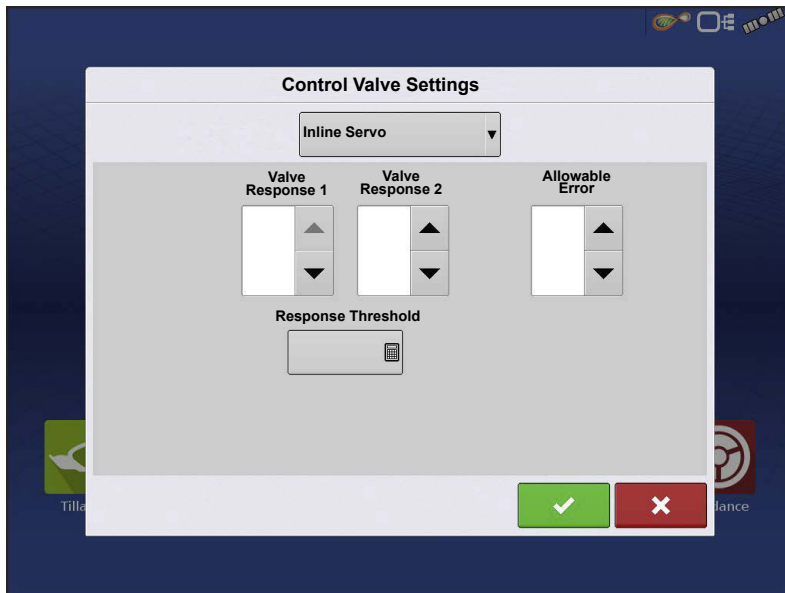

**Valve Response 1** — Determines the speed of the servo valve when product control error exceeds the Response Threshold setting. The default for this setting is 100%. Decreasing the value will cause the servo valve to run slower. Valve Response 1 represents the fast speed of the servo valve.

**Valve Response 2** — Determines the speed of the servo valve when product control error is less than the Response

Threshold setting. The default for this setting is 24%. Decreasing the value will cause the servo valve to run slower. Valve Response 2 represents the slow speed of the servo valve.

**Response Threshold** — Determines where the control channel switches between using Valve Response 1 and Valve Response 2 speed settings. The default setting is 3. Leaving

all other valve control settings at the default value and making a small adjustment to this setting is usually all that is required to fine-tune system performance.

- Decreasing this value will have the overall effect of speeding up servo valve response.
- Increasing this value will have the overall effect of slowing servo valve response.

## Calibrate Pressure

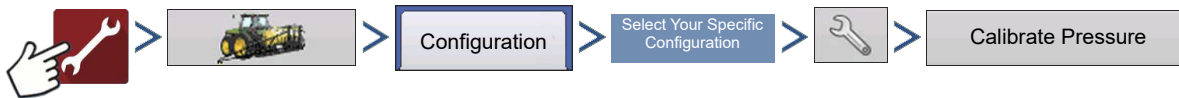

1. Choose Main, Agitation or Aux from drop-down box.
2. Enter pressure value as a set point or press Reset to Default button.

Enter voltage/pressure ratio.

- This is a constant per pressure sensor brand. Values are 16mV for Ag Leader and Raven, and 45mV for Dickey John. For other branded sensors, check with sensor manufacturer.

3. Press  to finish process.

## Liquid Application Diagnostics



To go to the Liquid Diagnostics screen, press



At the Devices screen, highlight the item marked **Liquid Product Module** then press the **Diagnostics** button.

The Liquid Diagnostics screen includes the Active Controller Name and the Serial Number of the module.

Other information provided includes the Main Pressure, Agitation Pressure, and Auxiliary Pressure. These raw sensor readings are shown in kilopascals (kPa).



**NOTE!:** If PWM is selected as the Control Valve then the current PWM Duty Cycle is shown as a percentage number, in the PWM Duty Cycle (%) item on the Liquid Diagnostic screen.

**Flow Meter Signal Frequency (Hz)** — View the frequency generated by the flow meter during product application. Use this to make sure the flow meter is providing continuous feedback.

**Flow Meter Pulse Count** — Provides a rolling count of pulses generated from the flow meter during product application. This diagnostic item can be used to easily check that the flow meter is providing feedback to the system and also provides a way to check flow meter cabling without changing settings within the system setup.

## Troubleshooting DirectCommand Liquid Applications

**Problem:** — Boom indicators on the run screen of the display do not turn green.

**Solution:**

1. Make sure ground speed is registering a value greater than zero on the display.
2. Verify a target rate greater than zero is entered into the display.
3. Check the switch status found on the Run screen under CAN and Input Diagnostics. As the boom switches are turned on and off, the Input Diagnostics window should change from black to green (if they do not, then refer to the installation instructions to verify boom switch connections).
4. Check high current connection into the Liquid Control Module.
5. Make sure the implement cable is plugged in. If plugged in, then test for 12 volts on pins A and B.
6. Turn AutoSwath off.

**Problem:** — Boom indicators on the Run screen of the display turn green, but the booms do not open.

**Solution:**

1. Check wiring connections for all of the boom valves.
2. Verify that the cabling is providing 12 volts to the boom valve on the signal pin.

Check for 12 volts on pins 1-10 on the boom connection of the liquid module.



**Problem:** — Boom valves pause up to 5 seconds before turning on by manual control.

**Solution:**

1. Verify that the display and Liquid Control Module are both updated to the latest available firmware.
2. The boom switch cable may be wired incorrectly. For details, refer to the installation instructions.

This issue should only occur on John Deere sprayers. Make sure the black wires in the switch cable are connected.

**Problem:** — Booms will not turn on when the foot pedal is on.

**Solution:** —Make sure the Master Switch Input is set to “External 2” under the Auxiliary Input Settings.

**Problem:** — AutoSwath turns on the boom too fast or too slow.

**Solution:**

1. Check GPS offsets in the vehicle setup to verify all the measurements are correct.
2. Verify implement offsets are appropriate for the sprayer.
3. Adjust the turn on look-ahead and turn off look-ahead to fine-tune Automatic Swath Control performance.
4. Verify Forward/Backward Section Offsets. If applicable - verify Section Offsets are correct if boom section(s) are independently offset.

**Problem:** — No “As Applied” rate

**Solution:**

1. Check cabling from the channel connection of the Liquid Control Module to the flow meter.
2. Check flow meter for product buildup and proper operation.

**Problem:** — Rate is erratic

**Solution:**

1. Verify that the rate display smoothing option is check marked in the Equipment Settings of the Configuration Setup.

- 
2. Check the controller settings of the active configuration. Verify that the valve settings are appropriate for their particular type of control valve being used.
  3. Use manual valve control to see if the rate stays constant.

**Problem:** — Erratic behavior from the flow meter and boom valves.

**Solution:**

1. Verify that the display firmware and module firmware are both current.
2. Verify that cabling has been installed correctly and that none of it has been pinched or damaged.

**Problem:** — No boom pressure at the start of the field.

**Solution:** — Before product application begins, use manual valve control to build boom pressure. Select either Rate 1 or Rate 2 once pressure is set to desired level. Enter the pass and allow automatic control to take over once the sections are turned on.

**Problem:** — AutoSwath checked on, but booms will not turn on.

**Solution:**

1. Make sure the ground speed is registering a value greater than zero on the display and not in the covered area.
2. Make sure there is a target rate greater than 0.
3. Make sure the applicator is inside of the field boundary.
4. Verify the implement switch (or implement switch jumper) is working appropriately.
5. Verify the Master Switch icon is indicating On (green) and Off (red) appropriately.

**Problem:** — Booms turn off in the middle of the pass.

**Solution:**

1. Check the display firmware and module firmware to see if they are the latest version released.
2. Make sure the ground speed does not go to 0.
3. Make sure the GPS is not losing the differential source.
4. Verify that cabling has been installed correctly and that none of it has been pinched or damaged.

**Problem:** — Rate not responding (error flashing)

**Solution:**

1. Make sure the flow meter calibration number matches the tag on the flow meter.

For Raven flow meters, divide the calibration number by 10.

2. Make sure that the flow being applied is not greater than the pump can produce.
3. Use manual valve control to see if the control valve will open or close.
4. Check the tip manufacturer's charts to make sure they are in the operating range of the application.
5. Check for any product buildup in the flow meter.
6. Check product filter for debris.

**Problem:** — Booms turn on when outside of the boundary.

**Solution:**

1. Make sure the Rate Outside of Field option is set to zero under the active configuration settings.
2. Make sure the Outside Boundary Option is set to Turn Section Off under the Automatic Swath Control options.
3. Make sure there is not a gap between the boundary and the first pass of the headlands.

**Problem:** — Booms turn on briefly (less than a second) in the headlands (previously covered area)

**Solution:**

1. Make sure that the turn on look-ahead is greater than the turn off look-ahead.
2. Make sure GPS offsets are correct.
3. Make sure look aheads are less than three seconds each.
4. Verify that the display and Liquid Control Module are both updated to the latest available firmware.

## Troubleshooting Serial Control Applications

**Problem:** Rate changes on the display, but not on the controlled console.

**Solution:**

- 
1. Verify the current firmware is running on the display and Application Rate module.
  2. Check the settings specific to controlled console.
  3. Check cabling and all connections.
  4. Disconnect the serial connection and determine if the controller is functioning properly without the display.

**Problem:** The display rate and serial-controlled rate do not match.

**Solution:**

1. Verify the current firmware is running on the display and the Application Rate Module.
2. Check the percent rate change.

## John Deere Specific Instructions

Here are some tips to remember when operating the display in conjunction with a SprayStar control system. Refer to other sections of the operators manual for specific setup and operation instructions.

**Master Source** — After setting up a configuration in the display make sure to change the Master Source setting from switch to External2. This will tell the display to read the foot pedal for the master switch input status.

**Master Switch Usage** — When manually shutting off all boom sections in the field, use the foot pedal switch. Leave the OEM master switch on the hydro handle ON during field use. Using the hydro handle switch may lead to improper field coverage, poor AutoSwath performance, and inaccurate spray records. Only use the John Deere master switch when completely shutting down the sprayer to transport or service the machine.

**Target Rate** — The display must have a non-zero target rate entered in the display before the boom valves will open for product application. Ensure that the target rate entered into the display and SprayStar match to avoid any unwarranted alarms or warnings on the display.

**Data Collection** — The display will create a coverage map of all product application while logging actual application rate from the product control system flow meter.

**AutoSwath Boom Section Control** — The display will automatically control the boom section on/off status based upon previously applied area, field boundary, and internal boundaries.

---

**SprayStar Application Rate** — The display will not control the rate based upon the target rate value entered into the system. Application rate is controlled exclusively by the SprayStar display.

**SprayStar Rinse Cycle** — When using the rinse cycle feature on the SprayStar, the display must have the boom sections on to allow the SprayStar to properly run the rinse routine. To ensure that boom sections are on:

1. Enter a target rate into the display.
2. Turn the foot pedal master switch on.
3. Turn all boom switches on.
4. Boom indicators on the Run screen must be green showing that boom valves are on.

## Control Valve Settings

### Liquid Product Control Valve Configuration Options

**Inline Servo** — Rate control is achieved through actuating a butterfly or ball valve found in the solution hose that goes to the booms. When the valve opens, the flow increases and when the valve closes, the flow decreases.

**Bypass Servo** — Rate control is achieved through actuating a butterfly or ball valve found in the return line to the solution tank. When the valve opens, the flow decreases and when the valve closes the flow increases.

**PWM 12 volt** — Rate control is achieved through speed changes to the solution pump. The PWM 12 Volt setting is programmed to pulse the power to an electric solenoid valve used to adjust the hydraulic flow to the solution pump.

**Pump Servo** — Rate control is achieved through speed changes to the solution pump. The pump servo setting is programmed to control an electric motor used to actuate a hydraulic valve to adjust the hydraulic flow to the solution pump.

**PWM Ground** — Rate control is achieved through speed changes to the solution pump. The PWM Ground setting is programmed to pulse the ground to an electric solenoid valve used to adjust the hydraulic flow to the solution pump.

**Calibrated Reflow** — Three-way boom valves are used to return product back to the tank in the off state. The returned flow is calibrated with adjustment at each valve. Calibration is required any time the nozzles are changed.

**Ramsey Valve** — A pneumatically-operated bypass valve. When air is supplied to the valve the rate increases; when air is released from the valve the rate decreases.

## Servo Control Valve Settings (By Manufacturer)

Flow Control Valve	Control Valve Configuration	Valve Response 1	Valve Response 2	Response Threshold
Raven Accu-Flow, 20 GPM Single Valve System (Fast Close Valve)	In-line servo	40%	10%	5
Raven Accu-Flow, 10 GPM Dual Valve System (Standard Valve)	In-line servo	100%	24%	5
Raven Accu-Flow, 30 GPM Single Valve System (Fast Close Valve)	In-line servo	40%	10%	5
Raven Accu-Flow, 30 GPM Dual Valve System (Standard Valve)	In-line servo	100%	24%	5
Raven Flow Control Valve, 3/4" (Standard Valve)	In-line or Bypass Servo	100%	24%	1
Raven Flow Control Valve, 3/4" (Fast)	In-line or Bypass Servo	40%	10%	5
Raven Flow Control Valve, 1" (Standard)	In-line or Bypass Servo	100%	24%	2
Raven Flow Control Valve, 1" (Fast)	In-line or Bypass Servo	40%	10%	5
Raven Flow Control Valve, 1 1/2" (Standard)	In-line or Bypass Servo	100%	24%	3
Raven Flow Control Valve, 2" (Standard)	In-line or Bypass Servo	100%	24%	8
Raven Flow Control Valve, 2" (Fast)	In-line or Bypass Servo	40%	10%	15
Raven Flow Control Valve, 3" (Standard)	In-line or Bypass Servo	100%	24%	15
Mid-Tech, 3/4"	In-line or Bypass Servo	40%	10%	5
Mid-Tech, 1"	In-line or Bypass Servo	40%	10%	8
Mid-Tech, 1 1/2"	n-line or Bypass Servo	40%	10%	11
Mid-Tech, 2"	n-line or Bypass Servo	40%	10%	15
Dickey-john NH3 Heat Exchanger	In-line Servo	40%	10%	8

# Liquid Rate Control

Flow Control Valve or Sprayer Model (and year if applicable)	Control System	PWM Frequency	Typical Gain Range	Zero Offset	Allowable Error	Valve Response 1	Valve Response 2	Response Threshold
Apache 510/710/ 1010/1210 (2006 and up)	In-line Servo				2%	100%	24%	Use a starting value of 5. See note below.
All Case IH sprayers when using AIM Command	AIM Command In-line servo				2%	100%	24%	3
Case IH Surveyor with A-post	Non-AIM Command Mode PWM 12-volt	122	**700-900	35	2%			
Case IH 3320	Non-AIM Command Mode PWM 12-volt	122	**700-900	35	2%			
Case IH 4420 with A-post	Non-AIM Command Mode PWM 12-volt	122	**700-900	35	2%			
Case IH 3200 (KZKCO Valve)	Non-AIM Command Mode By-Pass Servo				2%	40%	10%	5
Case IH 4260 with Raven valve	Non-AIM Command Mode By-Pass Servo				2%	100%	24%	3
Case IH 4260 with KZKCO valve	Non-AIM Command Mode By-Pass Servo				2%	40%	10%	5
Case IH 3150 with Raven valve	Non-AIM Command Mode In-Line Servo				2%	100%	24%	3
Case 3185 with Raven valve	Non-AIM Command Mode In-Line Servo				2%	100%	24%	3
Case IH 3310	Non-AIM Command Mode PWM 12-Volt	122	**700-900		2%			
Case IH 4410	Non-AIM Command PWM 12-Volt	122	**700-900		2%			
GVM Prowler (2007)	Pump Servo				2%	100%	24%	10
GVM Predator	Servo				2%	100%	24%	**See Note below
Hagie 284, 284XP, DTS-8	Pump Servo				2%	100%	24%	3
Hagie 2100, 2101, DTS-10	Pump Servo				2%	100%	24%	3
Hagie STS 10, 12, (2000 to 2005)	Pump Servo				2%	100%	24%	20
Hagie STS 10, 12, 14, 16 (2006 and up)	PWM 12-volt	122	**350-600	20	2%			
Hagie 39-pin Spray II switch box (2006 and 2007)	Calibrated Reflow				2%	100%	40%	2
John Deere 4700, 47X0, 49X0	No rate control provided							
Miller Nitro N1 and N2	Pump Servo				2%	100%	24%	20
Miller Nitro N4	Pump Servo				2%	100%	24%	12
Montana Paruda	Calibrated Reflow				2%	100%	40%	2(Imperial) or 11.4 (Metric)
RoGator 864, 874, 1064, 1074	PWM Ground		**500-700	30	2%			

Flow Control Valve or Sprayer Model (and year if applicable)	Control System	PWM Frequency	Typical Gain Range	Zero Offset	Allowable Error	Valve Response 1	Valve Response 2	Response Threshold
RoGator 1054	Pump Servo				2%	100%	24%	3
RoGator 1254	Pump Servo				2%	100%	24%	3
RoGator 1264, 1274 (up to 2006)	PWM Ground		**500-700	30	2%			
RoGator 1274, 1286, and SS Series (2007 and up)	PWM Ground		**500-700	30	2%			
Spra-Coupe 3X40, 3X50, 4X40, 4X50	In-Line Ground				2%	100%	24%	3
Spra-Coupe 7000 with factory pump switch	PWM Ground	122	**500-700	30	2%			
Spra-Coupe without factory pump switch	PWM Ground	122	**500-700	30	2%			
TerraGator XX03, XX04, XX44	In-Line Servo				2%	40%	10%	15
Tyler Patriot, Patriot II, XL, 150, 150XL and WT	Check for In-line Servo or By-Pass Servo Control				2%	100%	24%	3
Walker	Pump Servo				2%	100%	24%	3

\*Adjust this number to fit particular configuration.

\*\* Some adjustment may needed, if using a PWM control valve, to be made to achieve optimal pump response to the PWM gain value. Increase the Gain value to make the system more responsive; decrease the Gain value to smooth the system response.

## Dickey-John NH3 Conversions

### Conversion Formulas

The following formulas can be used to convert the Dickey John flow sensor constant to a value that represents pulses/gallon of anhydrous ammonia for use by the display

Formula for flow meter calibration for Dickey John reading pounds of anhydrous.

$$\frac{\text{Flow sensor constant (pulses/in}^3\text{)} \times 1728 \text{ (in}^3\text{/ft}^3\text{)} \times 5.11 \text{ (lbs of anhydrous/gal)}}{\text{Density (lbs. of anhydrous/ft}^3\text{)}}$$

Formula for flow meter calibration for Dickey John reading pounds of Nitrogen.

$$\frac{\text{Flow sensor constant (pulses/in}^3\text{)} \times 1728 \text{ (in}^3\text{/ft}^3\text{)} \times 4.22 \text{ (lbs of N/gal)}}{\text{Density (lbs. of N/ft}^3\text{)}}$$



**NOTE!:** The flow sensor constant is tagged on the Dickey-John flow meter. The density setting comes from a chart in the Dickey-John documentation and is not provided in this user guide.



## Fertilizer default Product Settings

Material	Type	Abbreviated name for display and predefined name for SMS™	Percentage (in terms of lbs. 100 lbs.)			Density
			N	P(P <sub>2</sub> O <sub>5</sub> )	K (K <sub>2</sub> O)	
Anhydrous Ammonia	Liquid under pressure	NH <sub>3</sub>	82	0	0	5.14 lbs./gal. (at 60°F)
28% UAN	Liquid	28% UAN	28	0	0	10.67
30% UAN	Liquid	30% UAN	30	0	0	10.86 lbs./gal.
32% UAN	Liquid	32% UAN	32	0	0	11.06 lbs./gal.
Ammonium polyphosphate (starter)	Liquid	Ammonium polyphosphate	10	34	0	11.73 lbs./gal.

## Glossary of Application Settings

### Configuration Settings

**Rate Outside of Field**—Rate that will be used outside of the field boundary. **Zero** stops product application. **Last Good** uses the previous rate before exiting the boundary. **Rx Default** uses the default rate written in the prescription file loaded.

**Rate Display Smoothing**—Determines how the feedback from the control channel's rate sensor will be displayed on the run screen. When checked, the system will display the target rate when the application rate is within 10% of the target rate setting. When unchecked the system will display the raw feedback from the rate sensor.

**Minimum Flow**—This setting is used to maintain a consistent spray pattern. The display will not allow flow to drop below the entered setting. Set to flow at the lowest operating pressure for the selected spray tips with all sections on. When spraying with one or more boom sections off, the system automatically reduces the minimum flow setting according to the reduced spray width.

**Rate Change Look-Ahead**—Compensates for any delay in the control system when changing between different product flow rates during variable rate application. This setting can be thought of as a "look ahead" value when using a variable rate prescription. The display will send the signal to change rates before hitting a transition line so that the applied rate is correct when crossing into the new management zone. The typical setting range for this is 0-1 seconds.

---

## Speed Input Settings

**Primary Speed Source**—Main speed input source used by the display.

**Backup Speed Source**—If the primary speed source fails, the display will use the backup if one is available.

**Manual Speed**—If both of the speed input sources are unavailable, manual speed can be used in order for the control channel to provide application. Manual speed setting is for use during static machine testing or by the control system in the absence of primary and backup speed signals.

## Automatic Swath Control Settings

**Turn-On Look-Ahead**—Determines how far ahead the system looks to turn the swath sections back on. This setting compensates for any delay in the product control system when the sections are turned on.

**Turn-Off Look-Ahead**—Determines how far ahead the system looks to turn the swath sections off. This setting compensates for delay in the product control system when the boom sections are turned off.

**Outside Boundary Option**—Determines the behavior of the sections when exiting the field boundary or prescription-mapped area.

**Coverage Option**—Based on the coverage option selected, this setting determines the behavior of the swath section when entering/exiting an already applied area or field boundary. Options available include: Minimize Skip, Minimize Overlap, and User Defined Percentage.

## Auxiliary Input Settings

**Master Source** — Switch that performs global master control of all rate control channels.

**F1-F11** — Settings determine the switch(es) that will operate the controlling channel specified from the configuration setup.

**Assign**—Screen where switch(es) can be assigned to specific controlling channels. Single switches can be used to control multiple channels and swath sections.

---

## Controller Settings

**Flow Meter Cal** — Calibration value representing the number of pulses that equal one-gallon of product flow through the controlling system.

**Control Valve Settings** — Setting specifies the type of control valve being used for the rate control functions of the controlling system.

**Response Threshold** — Determines where the control channel switches between using Valve Response 1 and Valve Response 2 speed setting.

**Valve Response 1** — Determines the speed of the servo valve when product control error exceeds the Response Threshold setting. Valve Response 1 represents the fast speed of the servo valve.

**Valve Response 2** — Determines the speed of the servo valve when product control error is less than the Response Threshold setting. Valve Response 2 represents the slow speed of the servo valve.

**Allowable Error** — Determines the percent of error that is allowed prior to the product control system making any flow rate changes.

**Flow Control Delay** — Setting for period of time from master switch on and the start of product application to the first flow control correction. This setting can be used to eliminate unwanted correction of flow control at the start of each pass. Typical setting values are zero for granular and 1 –2 seconds for liquid application control.

**Flow Control Valve**—When set to "Close," the controlling system shuts down when there is either a zero rate in the field or when entering an already-applied area. When set to "Hold," the controlling system remains in the last known state when all sections are shut off. If a PWM is the controlling system and the Flow Control Valve setting is set to "Hold," the valve will adjust to PWM Standby when all sections are shut off.

**Auxiliary Valve 1 & 2**—When all boom sections are off, this setting closes or opens an auxiliary valve. Choose settings for up to two auxiliary valves.

**PWM Frequency** — The frequency that the PWM control valve is pulsed at. Settings can be found from the manufacturer of the valve. Typical settings range from 100-125 Hz.

---

**PWM Gain** — Determines how aggressively the control valve responds when making rate change adjustments. The higher the value the more aggressive the system response is.

**Zero Flow Offset** — Represents the maximum duty cycle that is sent to the control valve without producing any hydraulic flow from the PWM valve. Using too high of a Zero Flow Offset value can cause the product control system to not properly control low rates or to shut off. See the PWM valve manufacturer information for recommended settings.

## Load Configuration



Press the Application App from the home screen to load a configuration.

## Map View

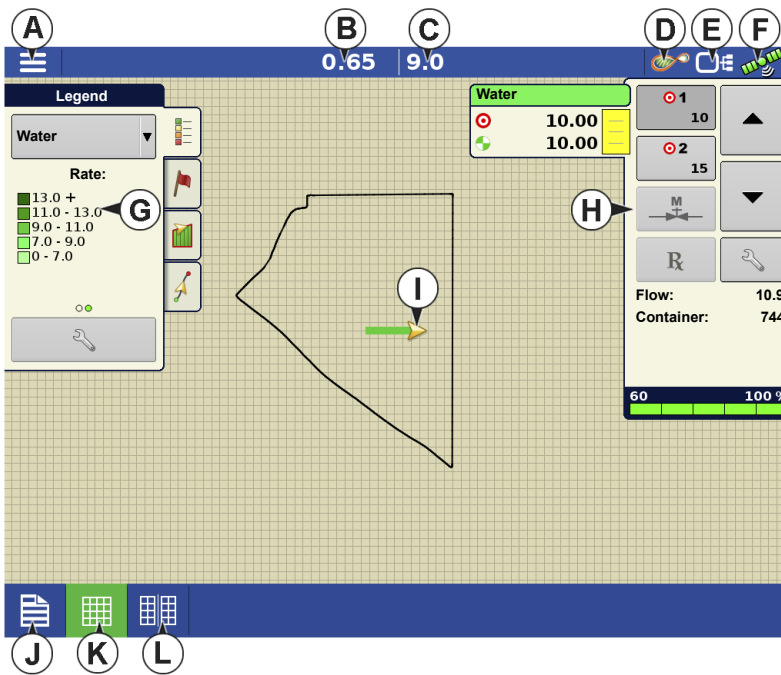

Once a configuration has been completed, the Map View screen appears.

A. Menu button

B. Total Logged Field Area

C. Ground Speed

D. AgFiniti® Status

E. Diagnostics

F. GPS Signal Indicator

G. Display Legend

H. Product Control toolbox

I. Vehicle Icon

J. Event Summary

K. Map View

L. Split screen



**NOTE!:** Pressing the Map View button will cycle between the available Map screen views, and the appearance of the Map View button changes.

## Product Control Toolbox

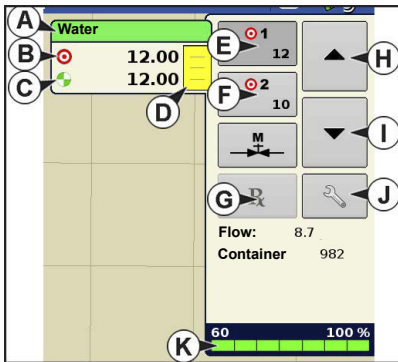

During DirectCommand™ Run Time operations, the Product Tabs are shown in the upper right-hand side of the Map screen. Press the Product Tabs, and an extended view shows the Rate buttons, Manual Valve Control button, Prescription button, Rate Increase and Rate Decrease arrows, and the Rate Setup button, all of which are described below.

- |                    |                             |
|--------------------|-----------------------------|
| A. Product         | G. Prescription button      |
| B. Target Rate     | H. Rate Increase arrow      |
| C. Actual Rate     | I. Rate Decrease arrow      |
| D. Container Level | J. Rate Setup button        |
| E. Rate 1 button   | K. Section Status Indicator |
| F. Rate 2 button   |                             |

**Target Rate**—The Target Rate is desired application rate.



**NOTE!** In some conditions, the Target Rate may increment more quickly than the Actual Rate.

**Actual Rate**—The Flow Sensor returns the actual rate being applied.



**NOTE!** In some conditions, the Actual Rate may increment slower than the Target Rate, or its numeric values may vary before matching the Target Rate.

**Container Level**—The Container Level shows the amount of product in the container.

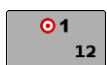



**Rate 1 and Rate 2 buttons**—The Rate 1 and Rate 2 settings represent preset application rates that allow operators to quickly change between desired target rates for each individual product.



**Manual Valve Control button** — (Not Available for this Operation) The Manual Valve Control button allows operators to specify the position of the control valve.

Operators use this option to prime the system before application or clean out the equipment at the end of the day.

**Rate Increase and Decrease Arrows** —  /  allow Product Application Rate to be changed according to the Target Rate Increment. In using manual valve control, the increase and decrease buttons allow the position of the control valve to be defined by the operator.

**Prescription button**— 

**Rate Setup button**— 

## Rate Control Settings

 Adjust the Rate 1 and Rate 2 settings shown at the Product Control Toolbox on the Map screen, as well as import application product prescriptions. To access the Rate Control Settings screen, press the Rate Setup button on the Product Control Toolbox. The Rate Control Settings screen appears.

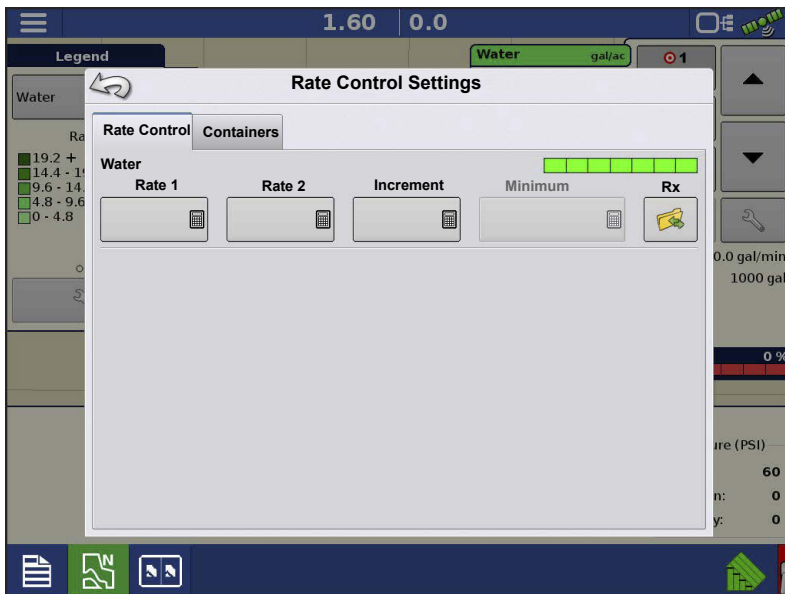

**Rate 1 and Rate 2** — The Rate 1 and Rate 2 settings represent preset application rates that allow operators to quickly change between desired target rates for each individual product. Press  to enter the desired amount.

**Increment** — The Increment button allows operators to specify the increase or decrease amounts for a

specified rate by using  /  on the Product Control Toolbox. Press  to enter the desired increment.

**Prescription** — To load a map-based prescription file, press the Prescription button.

Refer to [Loading Prescriptions on page 622](#) for further detail.

**Minimum Flow** — (Used for DirectCommand Liquid Applications only). This setting is used to maintain a consistent spray pattern. The display will not allow flow to drop below the entered

setting. Set to flow at the lowest operating pressure for the selected spray tips with all sections on. When spraying with one or more boom sections off, the system automatically reduces the minimum flow setting according to the reduced spray width. To adjust this setting, press  and enter the desired numeric value.

## Container Level Settings

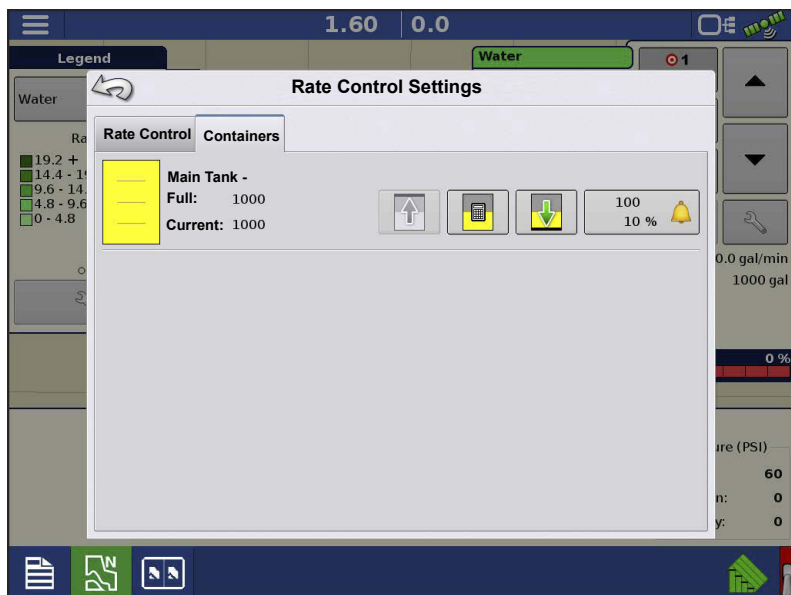

When filling or emptying container, use the Container Level portion of the Rate Control Settings screen to update the amount of product in the containers.

Container Level screen

 **Tank Fill** — The Tank Fill button increases the container level logged in the display to the user-defined maximum volume (specified in the Container Setup Wizard).

 **Tank Empty** — The Tank Empty button decreases the container level logged in the display to zero.

 **Tank Partial Fill** — The Tank Partial Fill button increases the container level logged in the display to specific amount specified by pressing calculator icon. Pressing the Partial Fill button summons the Adjust Container Amount screen.



## Adjust Container Amount

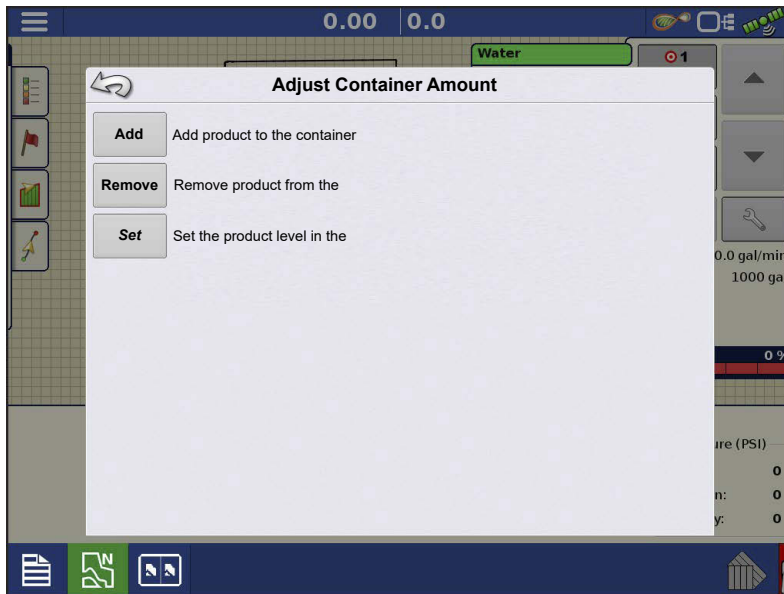

- **Add** — Adds product to the container.
- **Remove** — Removes product from the container.
- **Set** — Sets the product level in the container.

## Tank Alarms

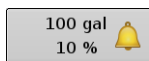

The Container Alarm button, which appears on the right of the Container Level portion of the Rate screen, displays the capacity of tank as well as the percentage at which the Low Container Level warning will sound. To adjust these settings, press the button and the Container Alarm screen appears.

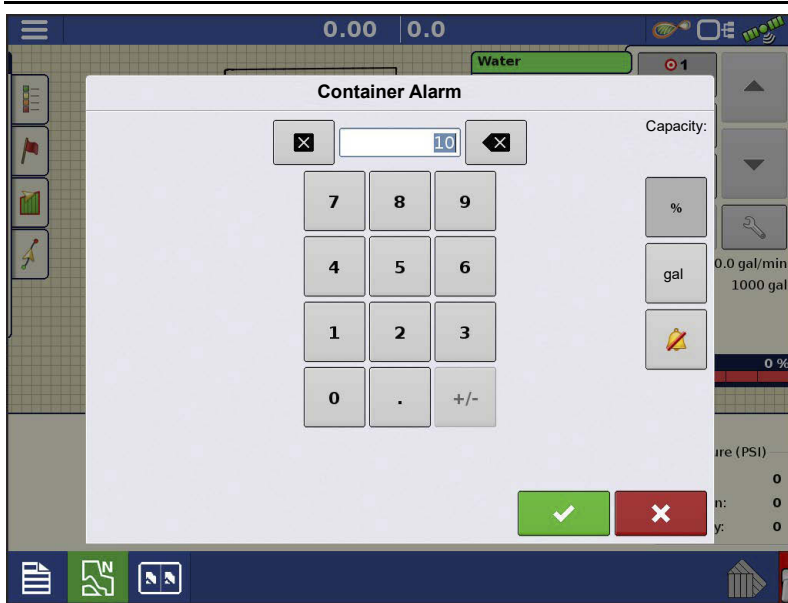

Adjust container level warnings using+ the following buttons on the right-hand side of the Container Alarm screen.

The **Percentage (%)** button sets the warning threshold according to the percentage of solution left in the tank. In the example above, the threshold is set at 10 percent.

The **Units of Measurement** icon sets the warning threshold according to the amount of solution left in the tank. This

icon is named according to the container’s units of measurement specified during the Controller configuration procedure.

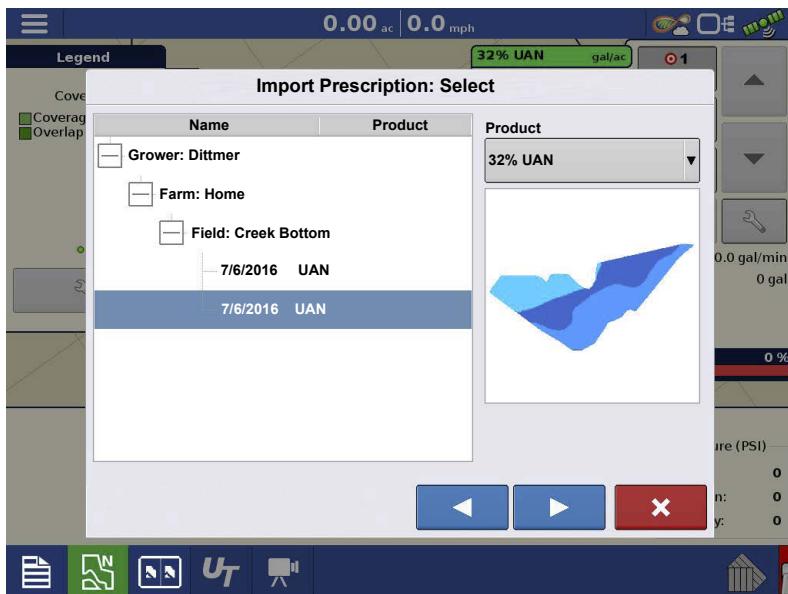

The **Disable Low Container Level** button, which appears as a bell with a red slash across it, disables the Low Container Level warning.

## Loading Prescriptions



1.  Press the Rate Setup button on the Product Control Toolbox.

2. Press the Load Prescription button.

3.  Using an inserted USB or AgFiniti Cloud, search for and highlight the correct .agsetup, .irx, or shape file and press .

4. Select the prescription in the Select

Prescription screen, and select the correct controlling product from the Product dropdown box. A preview prescription map is displayed. Press .

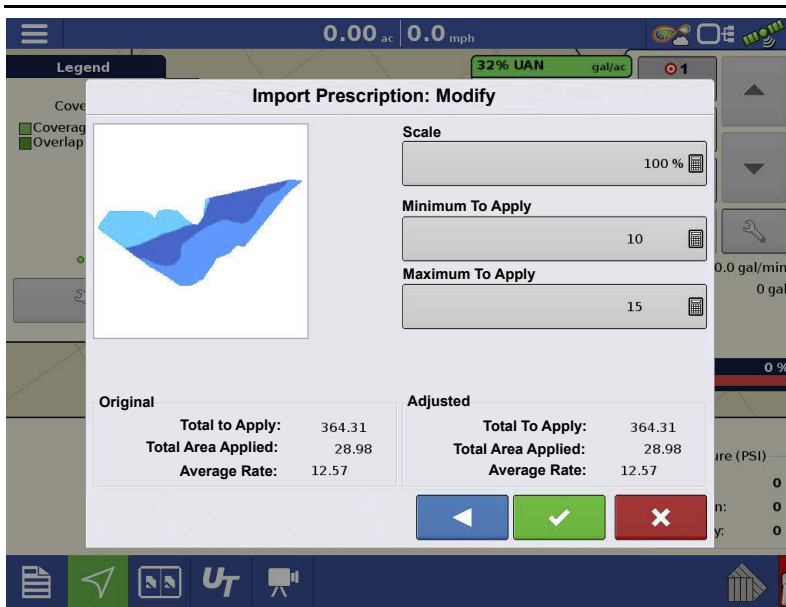

5. In the Modify Prescription Screen the prescription scale, minimum to apply, and maximum to apply can be changed. As the three parameters are changed, the adjusted total to apply and average rate will update accordingly.

6. Press the .

7. After returning to the Mapping Screen, the prescription will appear on

the map while in a North Oriented view.

## Shape File Conversion

What is commonly called a shape file is actually a collection of three different files. All three of the files are required and must be present on the USB drive for the system to use shape file groups for variable rate product application. A single "shape file" can contain recommendation rates for multiple products.



1. To begin, press the Rate Setup button on the Product Control Toolbox.

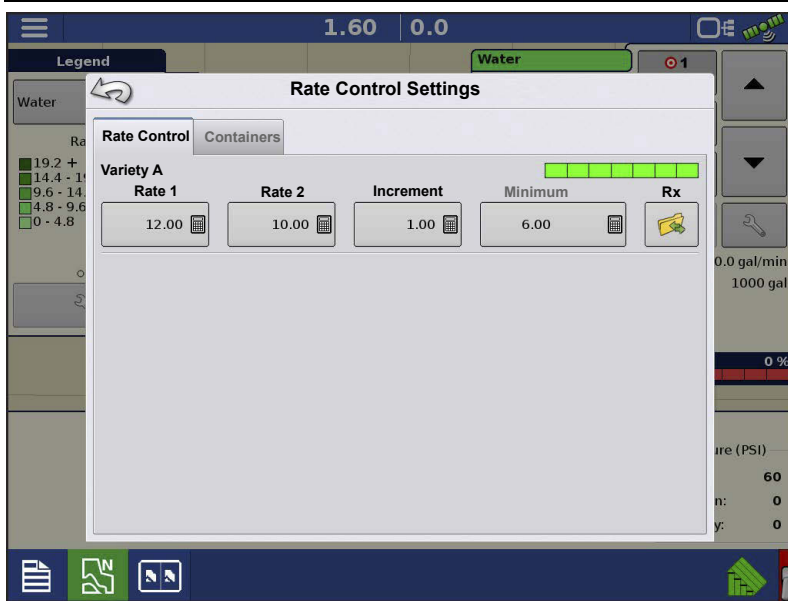

The Rate Control Settings screen appears

2.  Press the Load Prescription button.

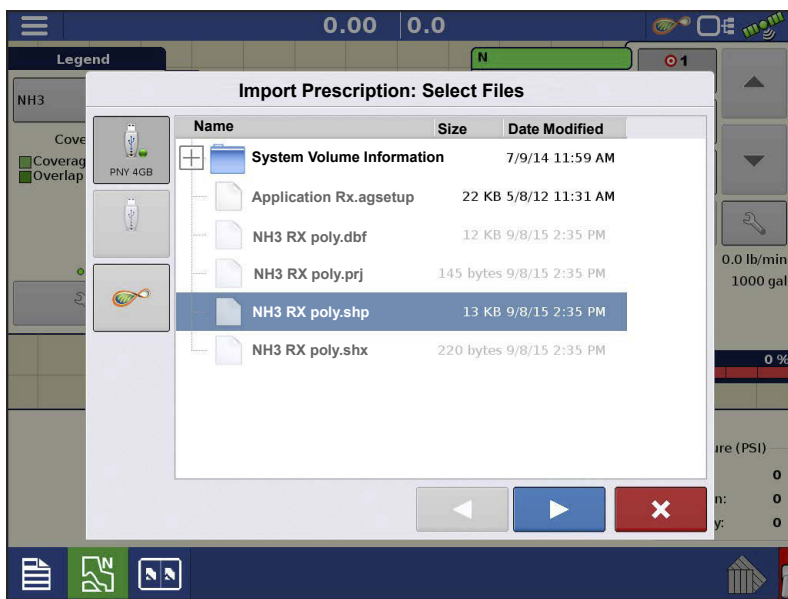

3. The Select File screen appears. Highlight desired .shp file and press



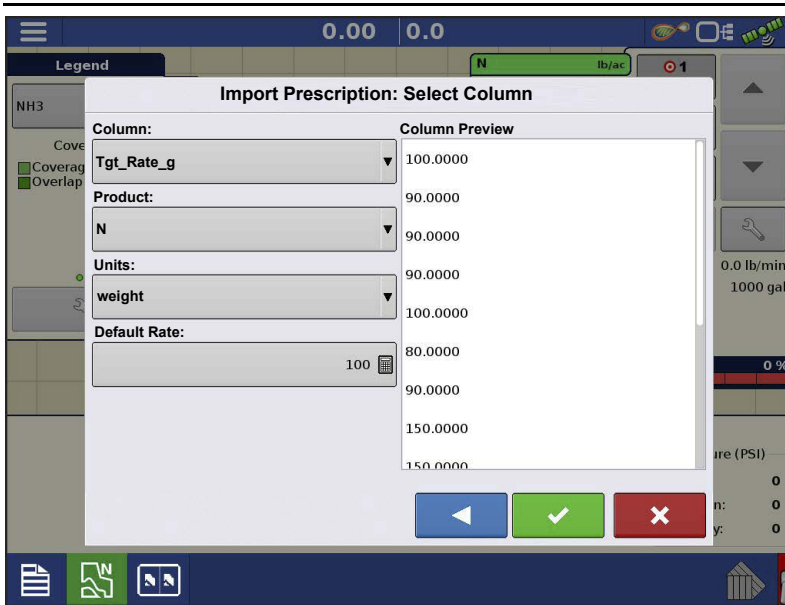

#### 4. Select Column From Shape File—

Select the column that contains the product recommendation rate. The list on the right side of the dialog shows sample data from the selected column.

5. **Select Units**—Select the controlling units for product application.

6. **Default Rate Setting**—The system assigns a default rate. Use the on-screen keypad to edit the value if

desired.



**NOTE!:** Select the product and units that the shape file prescription was made for. Selection of the wrong data column or unit will result in misapplication of product.



**ATTENTION!:** The only time the default rate is used by the system during product application is if the Rate Outside of Field selection is set to "Rx default". This setting is located in the equipment configuration settings portion of configuration setup. If the Rate Outside of Field selection is set to "Rx default", the default target rate will be used when the vehicle exits the area covered in the prescription map.

## Creating Products

Creating application products and product templates can be completed during initial setup or from the Product Selection screen of the Field Operation Wizard when starting a field operation.

### Creating Single Products

To create a single product, to be added to a product template or to be applied by itself, use the on-screen wizard described in the following steps.



---

Select:

1. Product Type
2. Product Units
3. EPA Product Number (Optional)

Check box if product is a Restricted Use Pesticide

4. Manufacturer name if applicable. Manufacturer name can be added to the drop-down menu

by pressing .

5. Press  to enter a unique name for the product.

Created product should appear under the Application heading located on the Product tab of the Configuration Setup screen.



**NOTE!:** Some Fertilizer and Carrier product types are predetermined in the display. These product names cannot be edited. Their Manufacturer and EPA Numbers can be edited after the product is created. Examples are: Fertilizer>DAP or Carrier>30% UAN.

## Creating Product Template

Product Templates are set up by using the on-screen wizard.



**NOTE!:** Prior to making a new product template, it is recommended to add the individual products to the list in the units recommended by the chemical label.

It is recommended to create product templates that contain the products applied for a crop type or time of the season.

Examples are:

- Pre-Emerge Burndown
- Post-Emerge Corn
- Post-Emerge Beans
- Insecticide
- Fungicide

In each template the products can be checked on/off for the mix when loaded at the run screen.



## 1. Select Tank Mix

### Define By

- Total amounts - mix/blend defined by amounts added to the tank (total of each product in tank)
- Rate/acre - mix/blend defined by the amounts applied per acre (rate of each product applied/area)

## 2. Enter a Base Amount or Base Rate and Units.

- Total Amounts - Tank/Bin Size
- Rate/Acre - For Rate Applied per Acre

## 3. Select Carrier



- Press  to create a new carrier.

## 4. Press by the Add Mix/Blend Contents box to start the process of adding components to the mix.

## 5. Select the desired component from the drop-down menu.



**NOTE!:** More than 7 products can be part of a template, but only 7 or fewer can be active at the same time.

- A new product can be set up at this time by pressing (+ icon) and following the Product Setup Wizard.
- Press  to add selected product, or press  to return to Add Mix/Blend screen without adding a product.



## 6. Press to add an additional product.

## 7. When all components have been added press .

## 8. Enter Manufacturer name is applicable.

- 
- Manufacturer name can be added to the drop-down menu by pressing .

9. Press  to enter a unique name for the mix/blend.

- Press  to complete the process of setting up the mix/blend, or press  to return to the Configuration Setup screen without adding a mix.

The product mix/blend appears under the Application heading located on the Product tab of the Configuration Setup screen.



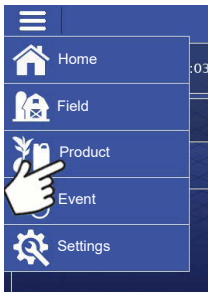

Represents Product Templates

## Configure Product Mix

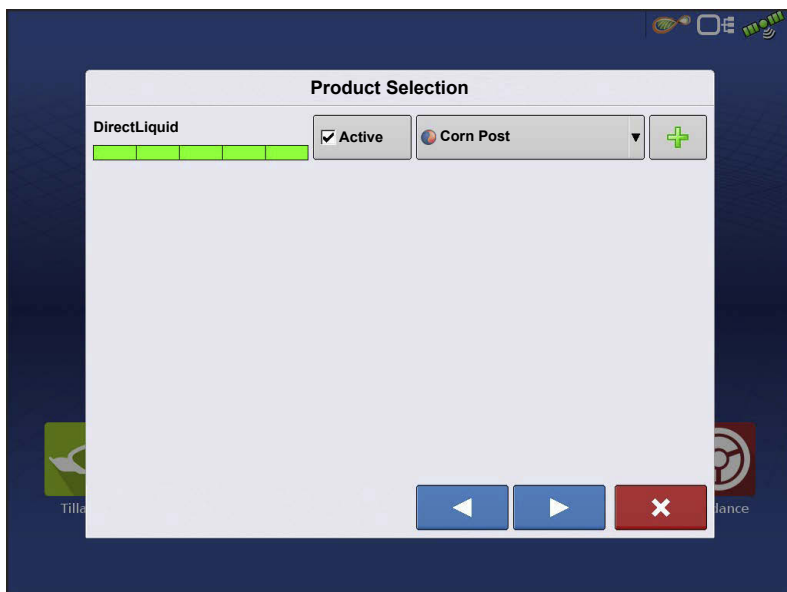

When using a product template, the mix contents and amounts are defined in the Configure Product Mix screen available in the Event Setup Wizard, or Product button in the main menu.



1. Select mix/blend from the drop-down list or press  to create and new mix/blend.



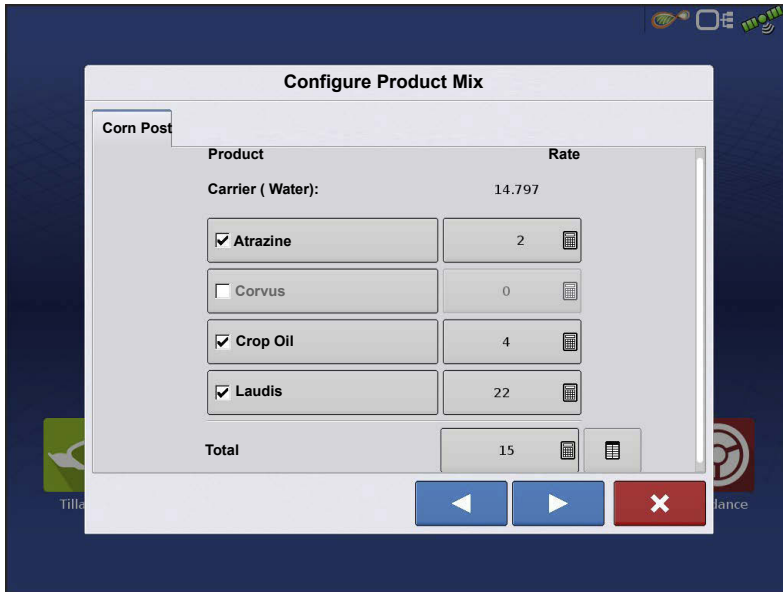

2. The product template mix contents and amounts are defined by:

- a. activating or de-activating products
- b. changing rate or total amount of product
- c. changing total amount of the product or overall rate of product application

A product can not be active with a rate of zero. Press  to access the Mix Calculator.

3. When a product template is setup using rate/area, the Mix Calculator can be used to show how much of each product to put in the tank when the user enters the desired amount to fill.

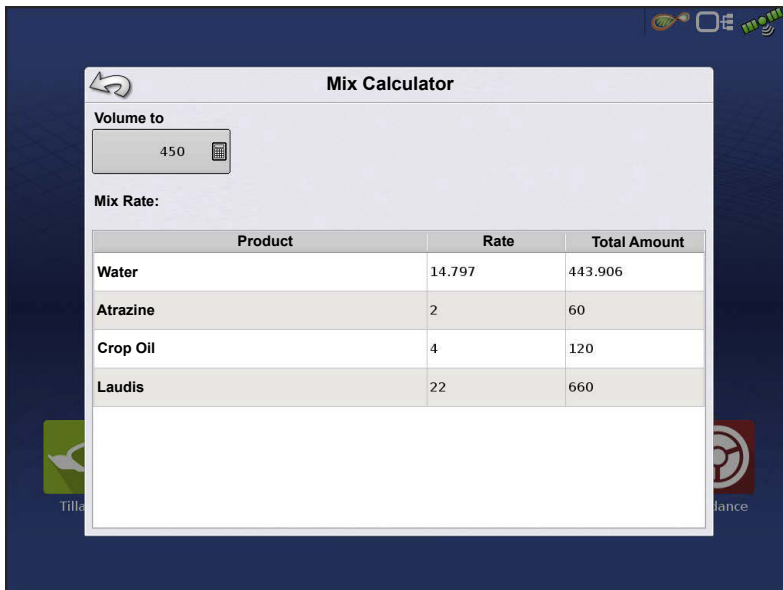

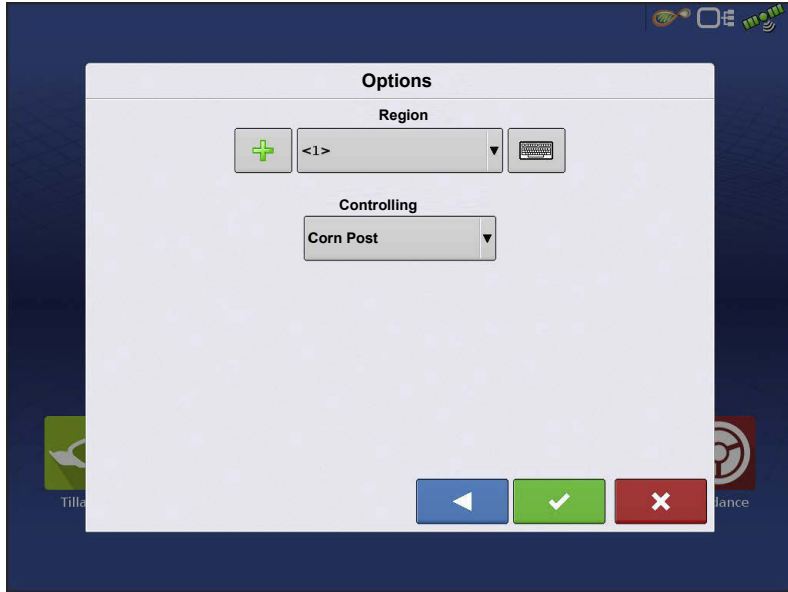

4. Press the Volume to Calculate button and input the total volume. Table will give the user the amount of each product to put in the tank.



5. Select Region from the drop-down menu or press  to name Region

Verify the Controlling Product for the Mix/Blend.

Press  to load the Event to the Map Screen, or press  to return to Home screen without setting up an Event.

## Create Configuration

To create a configuration, make the following button presses to start the Configuration Wizard and then follow the instructions given on the display. The configuration can be started in two places:



OR



OR

Planting

# Implement Offsets

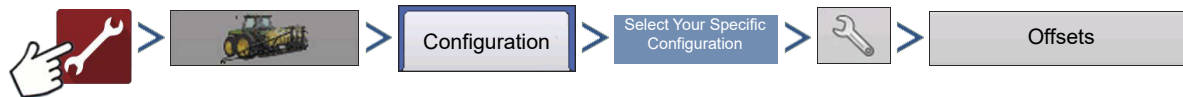

OR

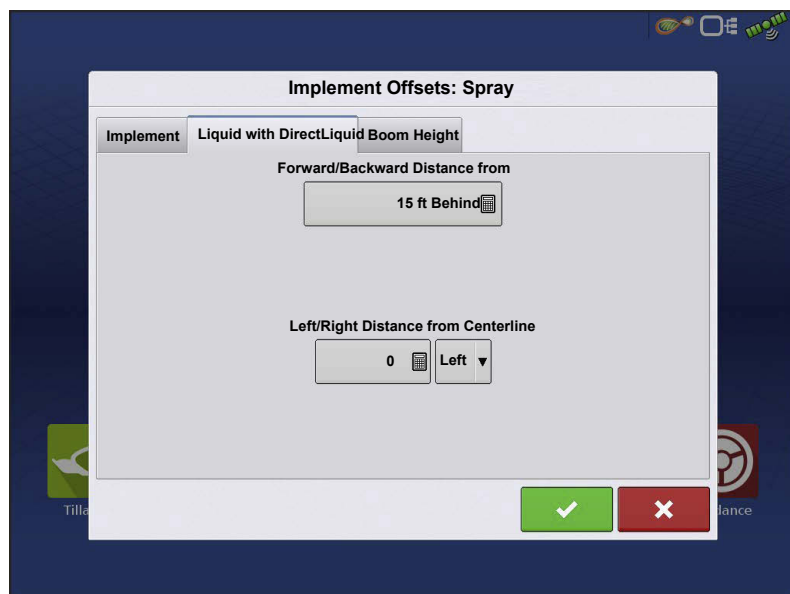
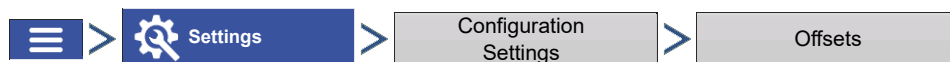

Implement Offsets screen appears, with each channel's settings shown on its own tab.

Defaults to the value entered during Configuration Wizard

Boom sections can independently be offset forward or back (application only)

1. Press  to access Swath Section Offsets screen.

# Serial Communication

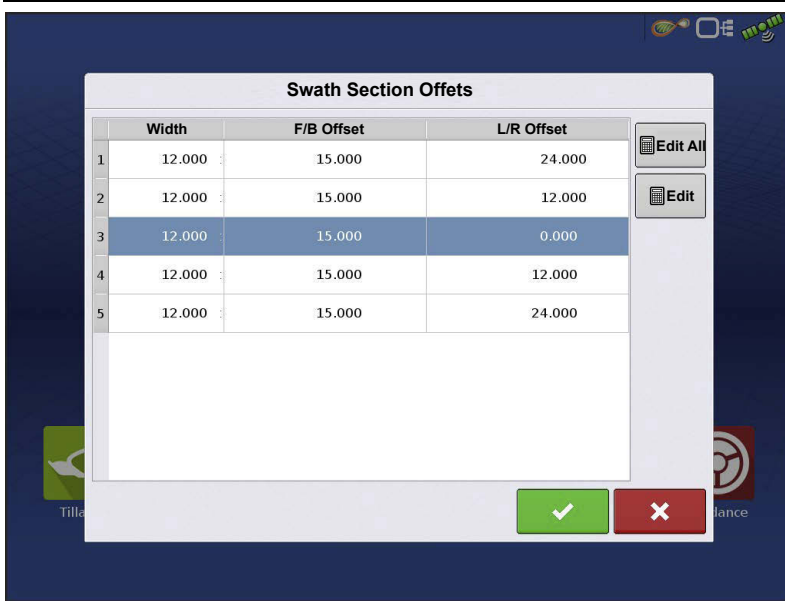

2. Select Swath section to edit and press Edit button.
  3. Enter Offset for that specific section and Forward/Backward from rear axle.
  4. Press  to enter change.
- Setup will indicate which offset is entered

 **Global**—All

sections have the same offset

 **Individual**—At least one section has a different offset

At least one section has a different offset

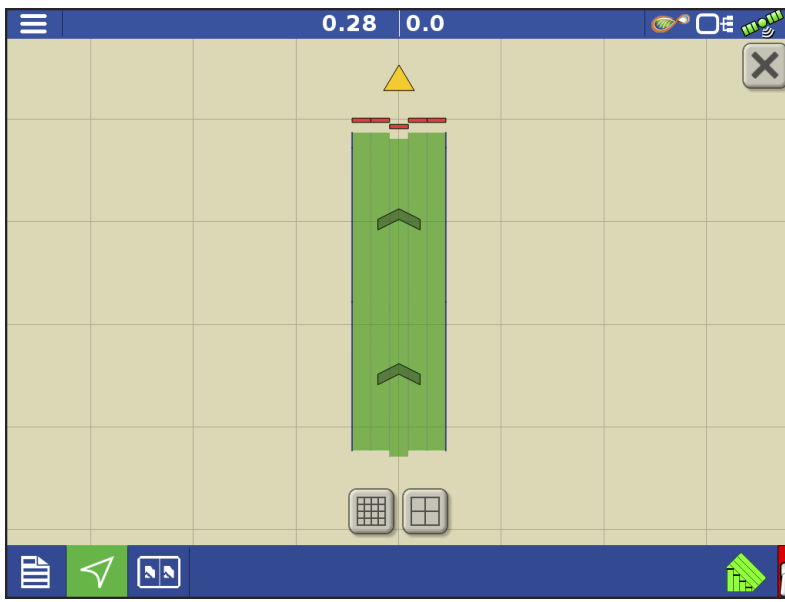

Runscreen reflects section offsets

## Equipment Settings

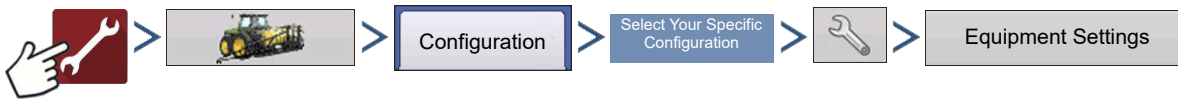

OR

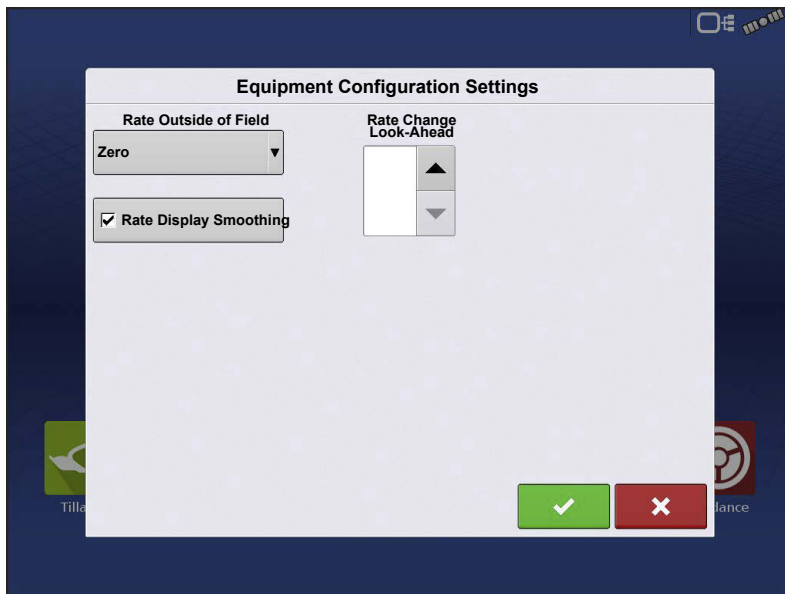
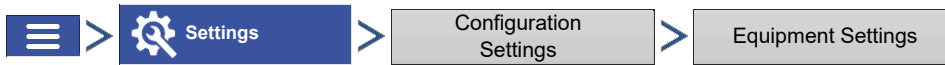

**Rate Outside of Field**—This setting will define how product will be controlled when leaving a field boundary.

**Zero**—This will stop application.

**Last Good**—This will continue application at the last known rate.

**Rx Default**—When using a prescription, this will apply at the Default Rate (or outside of boundary rate) as defined by the prescription file.

**Rate Display Smoothing**—

Determines how the feedback from the control channel rate sensor will be displayed on the map screen. When de-selected, the system will display raw feedback from the rate sensor. When checked, the system will display target rate when the application rate is within 10% of the target rate setting.

**Rate Change Look-Ahead**—This setting compensates for any latency in the control system when changing between different product flow rates during variable rate application. The typical setting range for this is 0-1 seconds. This setting can be thought of as a “look ahead” value when using a variable rate prescription. The display will send the signal to change rates before hitting a transition line so that the applied rate is correct when crossing into the new management zone.

## Module Layouts

Application Rate Module with serial cable connecting to Controller.

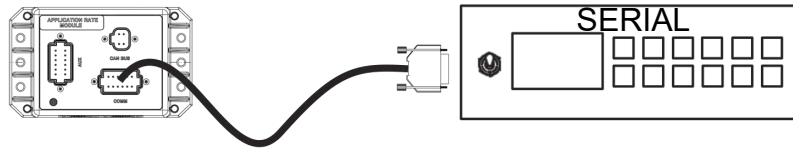

Application Rate Module with serial cable connecting to cable supplied by manufacturer (needed if listed in following tables). Manufacturer supplied cable connects to controller.



To verify the correct harness, the DB9 connector is:

- female for the 4000309-x (null) cable
- male for the 4000315-x (standard) cable

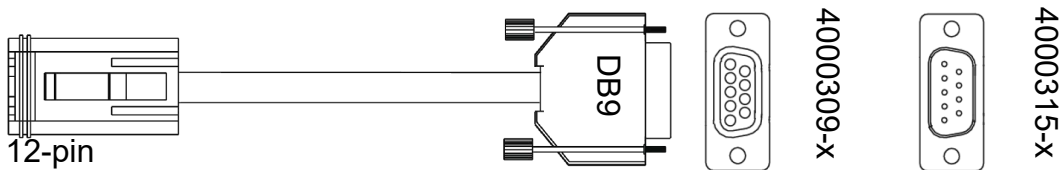

## Serial Control - Supported Controllers

Controller	Row Crop Planter	Seeders and Drills	Spreaders	Sprayer	Required Harness	Other Information
440	X			X	4000309-X	Harness connects directly to Raven Controller. Baud Rate = 9600 Trig = 1 Unit = Sec DLog = On Setting found in the Data Menu Setup
450				X	4000309-X	
460				X	4000309-X	
660			X	X	4000309-X	
700				X	4000309-X	
710				X	4000309-X	
750			X	X	4000309-X	
760			X	X	4000309-X	
Sidekick	X			X	4000309-X	

### Mid-Tech

Controller	Row Crop Planter	Seeders and Drills	Spreaders	Sprayer	Required Harness	Other Information
Ag-Logix			X	X	4000315-X	Harness connects directly to Mid-Tech controller. Requires Additional DataLink Module PN:78-050007
TASC 6000			X	X	4000315-X	
TASC 6100			X	X	4000315-X	
TASC 6200			X	X	4000315-X	
TASC 6300			X	X	4000315-X	
TASC 6500			X	X	4000315-X	
TASC 6600			X	X	4000315-X	

### Rawson

Accu-Plant	X		X		4000315-X	Harness connects directly to Rawson Controller. Requires setting the Rawson controller to GPS mode to enable serial communication.
Accu-Rate	X		X		4000315-X	

### New Leader

Mark III			X		4000315-X	Harness connects directly to New Leader controller
Mark IV			X		4000315-X	
Mark V			X		4000309-X	
SP 6			X		4000309-X	

### Flexicoil

FlexControl		X		X		Requires additional Flexicoil cable PN:14927
-------------	--	---	--	---	--	--

### Bogballe

Calibrator Uniq			X		4000309-X	Harness connects directly to Bogballe controller
Calibrator 2003			X		4000309-X	

### UNIA Group

BRZEG			X		4000309-X	Harness connects directly to BRZEG controller
-------	--	--	---	--	-----------	---

### Amazone

Amatron+		X	X	X	4000309-X	Harness connects directly to Amazone controller. Requires baud rate set to 19200 in the controller.
----------	--	---	---	---	-----------	--

### LH AGRO

LH5000			X	X	4000309-X	Harness connects directly to LH controller.
--------	--	--	---	---	-----------	---

### Kuhn

Quantron			X	X	4000309-X	Requires Kuhn cable ZPN:1409955
----------	--	--	---	---	-----------	---------------------------------

### Kverneland

Focus II		X	X	X		Contact Kverneland dealer for the correct cable
----------	--	---	---	---	--	---

### Vaderstad

Control Station		X	X	X	4000315-X	Requires RDS cable PN:428017
-----------------	--	---	---	---	-----------	------------------------------

### RDS

Pro			X	X	4000309-X	Requires RDS cable PN:CB268-1-032
-----	--	--	---	---	-----------	-----------------------------------

### Reco/Sulky

Vision-X			X	X		Requires Reco/Sulky cable PN:CB268-1-032
----------	--	--	---	---	--	--



---

### Troubleshooting Serial Control Applications—Liquid

**Problem:** Rate changes on the display, but not on the controlled console.

**Solution:**

1. Verify the current firmware is running on the display and Application Rate module.
2. Check the settings specific to controlled console.
3. Check cabling and all connections.
4. Disconnect the serial connection and determine if the controller is functioning properly without the display.

**Problem:** The display rate and serial-controlled rate do not match.

**Solution:**

1. Verify the current firmware is running on the display and the Application Rate Module.
2. Check the percent rate change.

### Troubleshooting Serial Control Applications—Granular

**Problem:** Rate changes on the display, but not on the controlled console.

**Solution:**

1. Verify the current firmware is running on the display and Application Rate module.
2. Check the settings specific to controlled console.
3. Check cabling and all connections.
4. Disconnect the serial connection and determine if the controller is functioning properly without the display.

**Problem:** The display rate and serial-controlled rate do not match.

**Solution:**

1. Verify the current firmware is running on the display and Application Rate Module.
2. Check to make sure the nominal rate in the display matches the nominal rate in the serial-controlled console.



---

## ISO Liquid Initial Setup Checklist

1. Build a System and profile in the Universal Terminal (UT) BEFORE building a display configuration.

Carefully follow steps 1-16 on pages [672- 678](#).

Reminders:

- a. Enable/disable Raven ISO Direct Injection, see step 7 on page [675](#).
- b. When using Flow Based Control (flow meter required), see step 10 on page [676](#).
- c. When using Pressure Based Control (pressure sensor required), see step 10 on page [676](#).
- d. Set Aux Valve(s) and/or Control Valve Behavior in step 12 on page [676](#) and step 13 on page [676](#).
- e. Enter GPS Offsets in step 15 on page [677](#). These offsets directly affect AutoSwath performance.

2. Create Nozzle(s) for pressure based control, pressure fallback, and droplet size monitoring (where applicable).

Carefully enter all Nozzle parameters on pages [680- 681](#).

Reminder:

Always perform catch tests to confirm manufacturer nozzle specifications.

- a. Use tip charts provided by nozzle manufacturer.

3. Follow Controller Setting configuration on page [682](#).

Reminder:

- a. Enter Prime/Standby Pressure settings (PWM only) on page [666](#).

4. Calibrate Flow Sensor and Pressure Sensor (where applicable). Begin on page [693](#).

Reminders:

Always perform catch tests to confirm manufacturer flow meter calibration values.

For Flow Based Control (pressure sensor optional)

- a. Enter Flow Sensor (meter) calibration value. See page [695](#).
- b. When applicable, enter Fallback Threshold for system to switch between flow-based control and pressure-based control on page [667](#) (pressure sensor required).

For Pressure Based Control (pressure sensor required)

- a. Calibrate Main Pressure Sensor on page [702](#).
- b. Select previously created nozzle on Mapping screen. See as shown on page [Liquid Control Options on Liquid Control Options on page 642](#).

---

c. Verify product density is correct via Mapping Screen as shown on page [642](#).

5. Assign Switches via UT. Refer to [Auxiliary Assignments Feature User Guide](#).

Reminder:

When using Ag Leader CAN-A DirectCommand switchbox, “Auxiliary Module Support” must be checked in the display ISOBUS Settings shown in the [Auxiliary Assignments Feature User Guide](#).

6. Verify speed source in the UT. See [At a Glance—Universal Terminal on page 641](#).

Reminder:

For Ag Leader displays

a. Check mark Broadcast Display Speed (ISO GBSD) in the Display ISOBUS Settings as shown in [Auxiliary Assignments Feature User Guide](#).

For 3rd Party Displays

a. Verify display manufacturer’s speed source is set properly for 3rd party ISOBUS ECUs.

7. Build the display operating configuration and load the product, grower, farm, and field for the operation.

Reminder:

For InCommand1200

a. The Load and Go feature will auto-create the ISOBUS controller.

For other Ag Leader and 3rd party displays

a. User must manually create an ISOBUS controller. See display manufacturer’s operator manual for proper display configuration.

8. Select desired Target Rate on the UT or mapping screen. See [At a Glance—Universal Terminal on page 641](#).

9. Verify performance and functionality.

Reminder:

a. Operate applicator to evaluate performance, and then adjust control valve settings as needed on page [682](#).

b. Configure/adjust AutoSwath section Look-Ahead Settings on page [685](#).

10. Applicator is ready for use.

## At a Glance—Universal Terminal

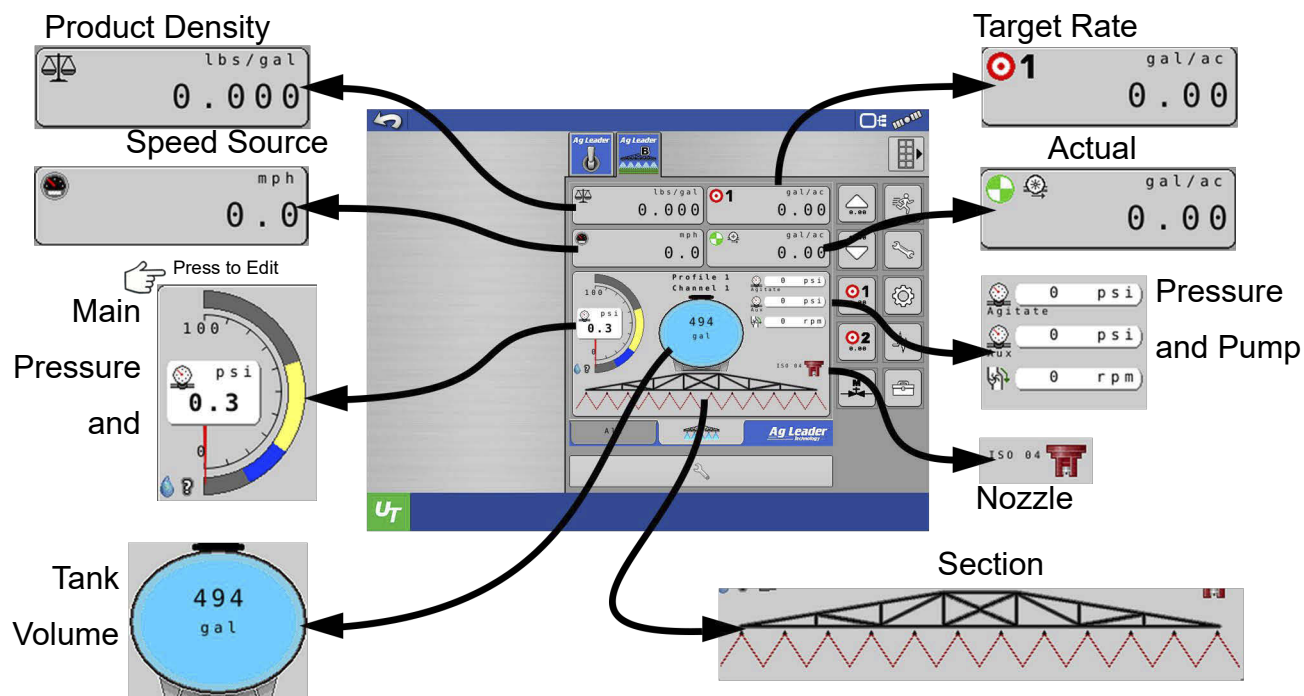

**ATTENTION!:** Pages 643 - 659 are specific to Ag Leader display functions. If the ISO Liquid Rate Control is being operated through another ISO display, refer to pages 660 - 718 for Universal Terminal specific functions.

## At a Glance—With Ag Leader Display

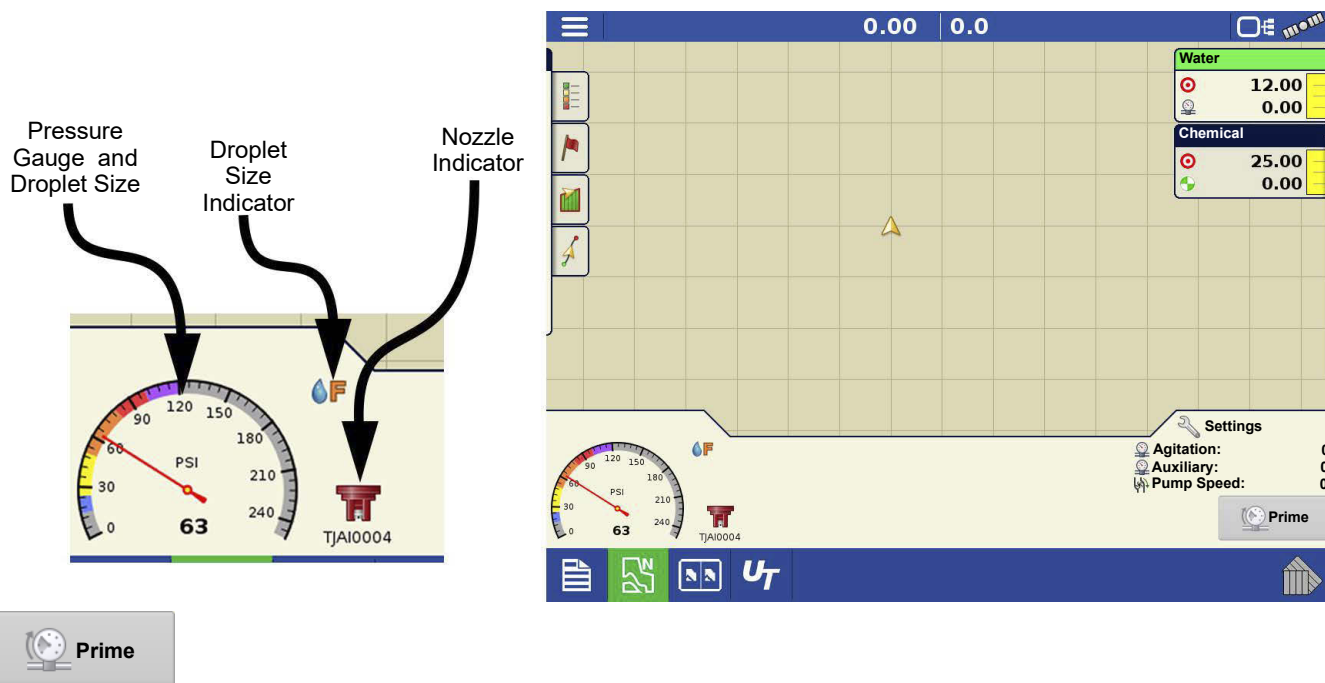

Pressing the **Prime** button will bring the system up to the defined Prime/Standby pressure and hold it. This feature is only available when a PWM control valve and pressure sensor are utilized.

## At a Glance—With Ag Leader Display

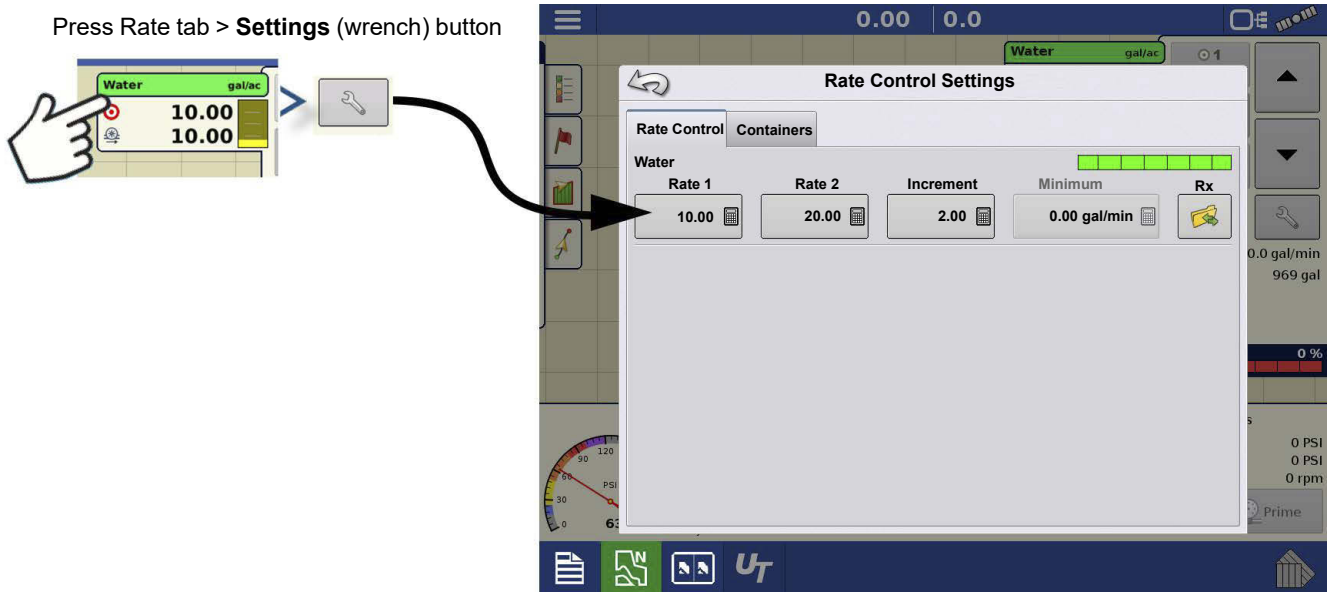

### Liquid Control Options

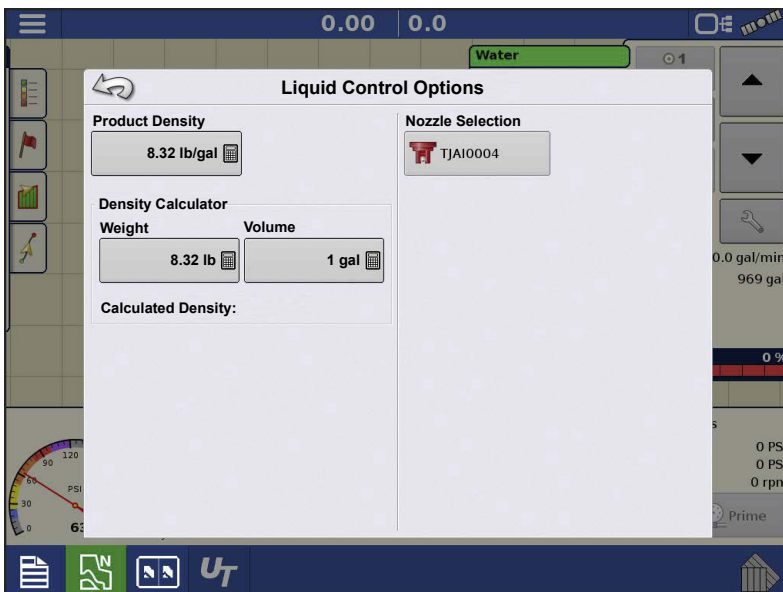
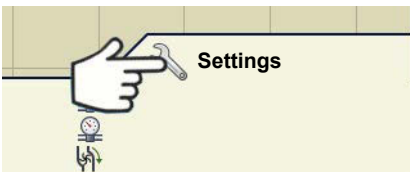

Press **Settings** tab to access Liquid Control Options screen.

Go to Liquid Control Options screen.

**NOTE!** The user can calculate the density by entering the known weight and volume.

Select the nozzle that will be used on the machine.

**i NOTE!:** Product Density and Nozzle Selection are required for pressure based control. If there is not a nozzle present to select, the user must add one in the module.

**👉 ATTENTION!:** Ag Leader display functions start at [At a Glance—With Ag Leader Display on page 641](#). If the ISO Liquid Rate Control is being operated through another ISO display, refer to [on page 660](#).

## Load Configuration

 Press the Application App from the home screen to load a configuration.

**i NOTE!:** If a System or Profile has not been setup yet in the Universal Terminal, please refer to [System Settings on page 686](#) and/or [Profiles on page 672](#) before loading a configuration.

## Map View

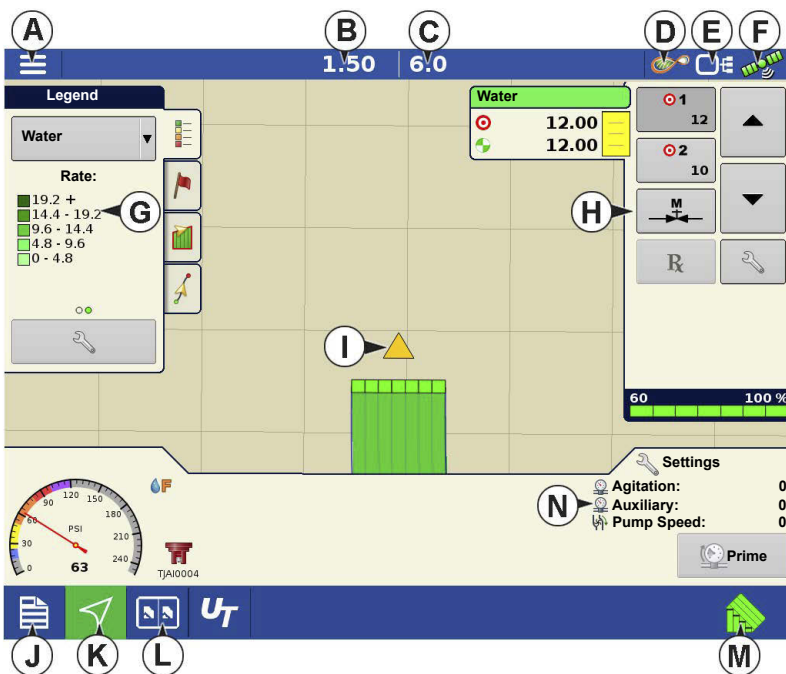

- A.Menu button
- B.Total Logged Field Area
- C.Ground Speed
- D.AgFiniti® Status
- E.Diagnostics
- F.GPS Signal Indicator
- G.Display Legend
- H.Product Control toolbox
- I.Vehicle Icon
- J.Event Summary
- K.Map View

L. Split screen

M. AutoSwath™

 **NOTE!:** Pressing the Map View button will cycle between the available Map screen views, and the appearance of the Map View button changes.

## Product Control Toolbox

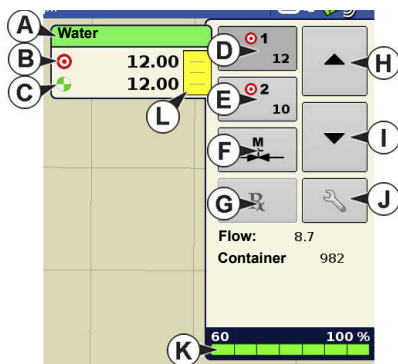

During DirectCommand™ Run Time operations, the Product Tabs are shown in the upper right-hand side of the Map screen. Press the Product Tabs, and an extended view shows the Rate buttons, Manual Valve Control button, Prescription button, Rate Increase and Rate Decrease arrows, and the Rate Setup button, all of which are described below.

- |                         |                             |
|-------------------------|-----------------------------|
| A. Product              | G. Prescription button      |
| B. Target Rate          | H. Rate Increase arrow      |
| C. Actual Rate          | I. Rate Decrease arrow      |
| D. Rate 1 button        | J. Rate Setup button        |
| E. Rate 2 button        | K. Section Status Indicator |
| F. Manual Valve Control | L. Container Level          |

**Target Rate**—The Target Rate is desired application rate.

 **NOTE!:** In some conditions, the Target Rate may increment more quickly than the Actual Rate.

**Actual Rate**—The Flow Sensor returns the actual rate being applied.

 **NOTE!:** In some conditions, the Actual Rate may increment slower than the Target Rate, or its numeric values may vary before matching the Target Rate.

**Container Level**—The Container Level shows the amount of product in the container.

 **Rate 1 and Rate 2 buttons**—The Rate 1 and Rate 2 settings represent preset application rates that allow operators to quickly change between desired target rates for each individual product.





**Manual Valve Control button** — The Manual Valve Control button allows operators to specify the position of the control valve. Operators use this option to prime the system before application or clean out the equipment at the end of the day.

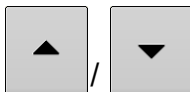

**Rate Increase and Decrease Arrows** — allow Product Application Rate to be changed according to the Target Rate Increment. In using manual valve control, the increase and decrease buttons allow the position of the control valve to be defined by the operator.

**Prescription button**— 

**Rate Setup button**— 

## Rate Control Settings



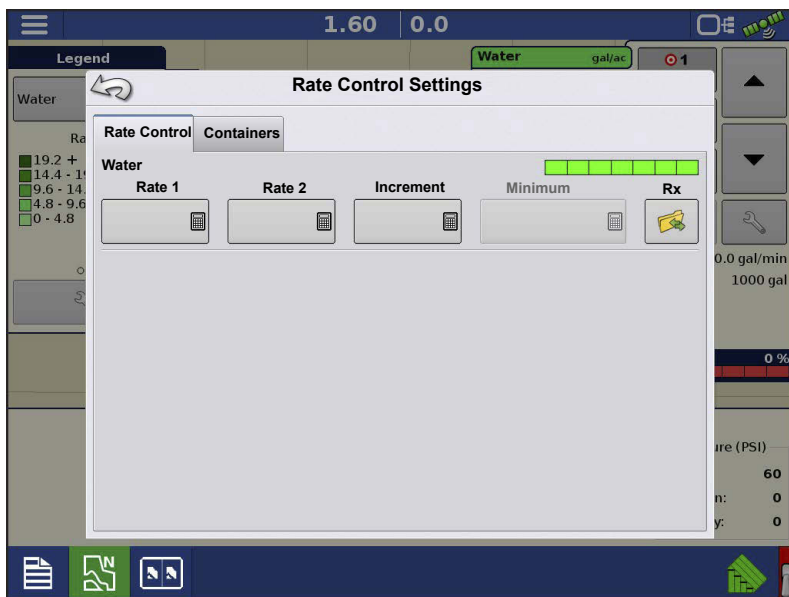

Adjust the Rate 1 and Rate 2 settings shown at the Product Control Toolbox on the Map screen, as well as import application product prescriptions. To access the Rate Control Settings screen, press the Rate Setup button on the Product Control Toolbox. The Rate Control Settings screen appears.



**Rate 1 and Rate 2** — The Rate 1 and Rate 2 settings represent preset application rates that allow operators to quickly change between desired target rates for each individual product. Press  to enter the desired amount.

**Increment** — The Increment button allows operators to specify the increase or decrease amounts for a

specified rate by using  /  on the Product Control Toolbox. Press  to enter the desired increment.

**Prescription** — To load a map-based prescription file, press the Prescription button.

**Minimum Flow** — (Used for DirectCommand Liquid Applications only). This setting is used to maintain a consistent spray pattern. The display will not allow flow to drop below the entered setting. Set to flow at the lowest operating pressure for the selected spray tips with all sections on. When spraying with one or more boom sections off, the system automatically reduces the minimum flow setting according to the reduced spray width. To utilize Minimum Flow, nozzles will need to be setup in the Universal Terminal. Once a nozzle is setup, Minimum Flow is calculated based off of the nozzles specifications. Refer to [Nozzles](#) on [page 680](#) for further detail.

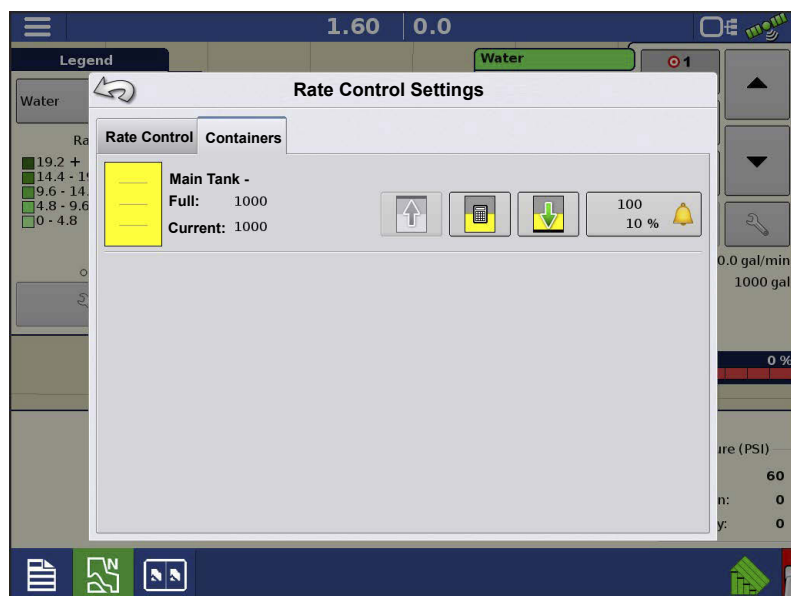

## Container Level Settings



When filling or emptying container, use the Container Level portion of the Rate Control Settings screen to update the amount of product in the containers.

Container Level screen

Container Level may also be adjusted from the Universal Terminal.

-  • **Tank Fill** — The Tank Fill button increases the container level logged in the display to the user-defined maximum volume (specified in the Container Setup Wizard).
-  • **Tank Empty** — The Tank Empty button decreases the container level logged in the display to zero.
- 

- **Tank Partial Fill** — The Tank Partial Fill button increases the container level logged in the display to specific amount specify by pressing calculator icon. Pressing the Partial Fill button summons the Adjust Container Amount screen.

## Adjust Container Amount

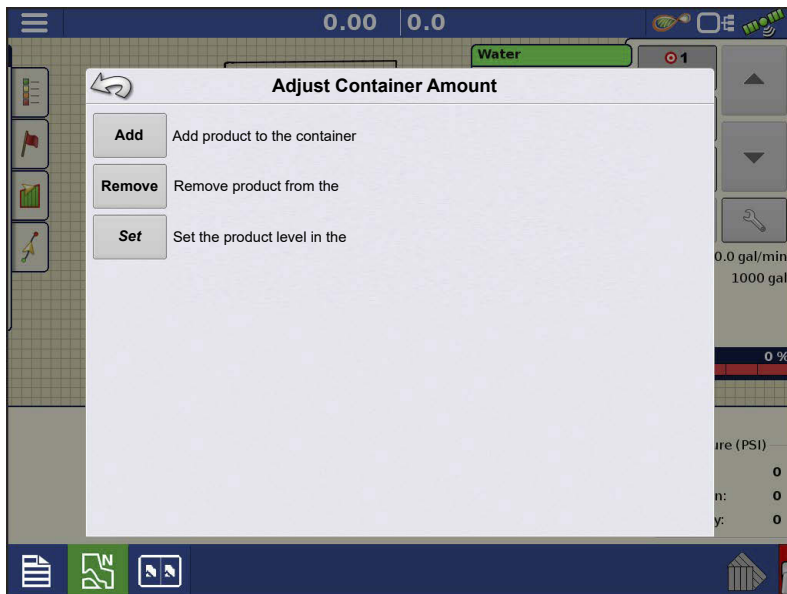

- **Add** — Adds product to the container.
- **Remove** — Removes product from the container.
- **Set** — Sets the product level in the container.

## Tank Alarms

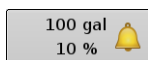

The Container Alarm button, which appears on the right of the Container Level portion of the Rate screen, displays the capacity of tank as well as the percentage at which the Low Container Level warning will sound. To adjust these settings, press the button and the Container Alarm screen appears.

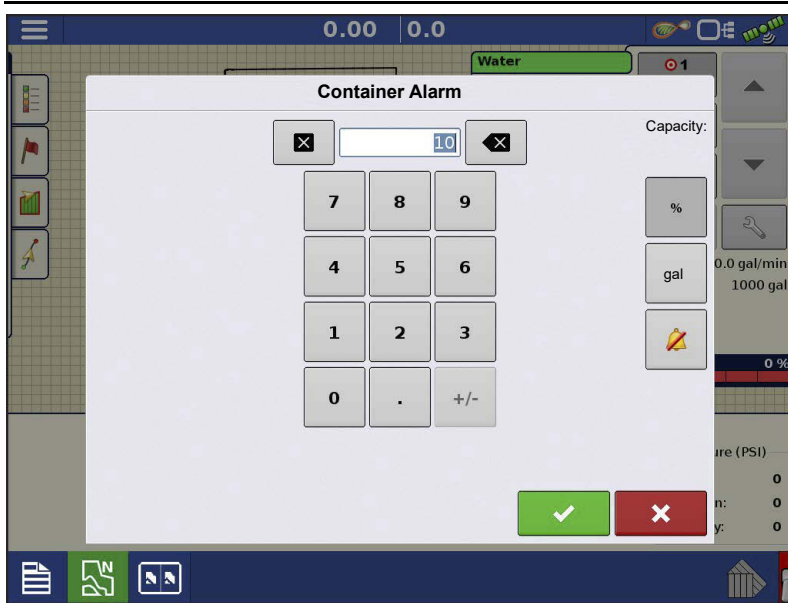

Adjust your container level warnings, use the following buttons on the right-hand side of the Container Alarm screen.

The **percentage (%)** button sets the warning threshold according to the percentage of solution left in the tank. In the example above, the threshold is set at 10 percent.

The **units of measurement** icon sets the warning threshold according to the

amount of solution left in the tank. This icon is named according to the container's units of measurement you specified during the Controller configuration procedure.

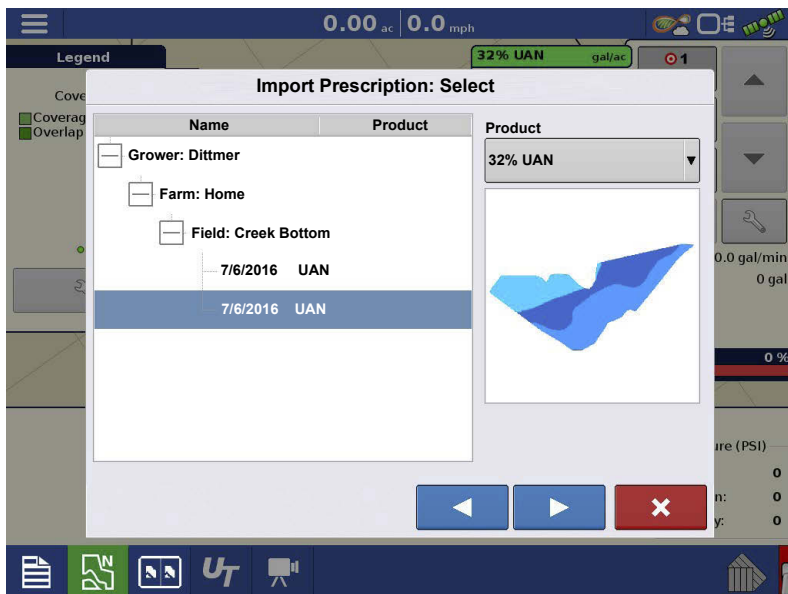

The **Disable Low Container Level** button, which appears as a bell with a red slash across it, disables the Low Container Level warning.

## Loading Prescriptions



1.  Press the Rate Setup button on the Product Control Toolbox.

2. Press the Load Prescription button.

3.  Using an inserted USB or AgFiniti Cloud, search for and highlight the correct .agsetup, .irx, or shape file and press .

4. Select the prescription in the Select Prescription screen, and select the

correct controlling product from the Product dropdown box. A preview prescription map is displayed. Press .

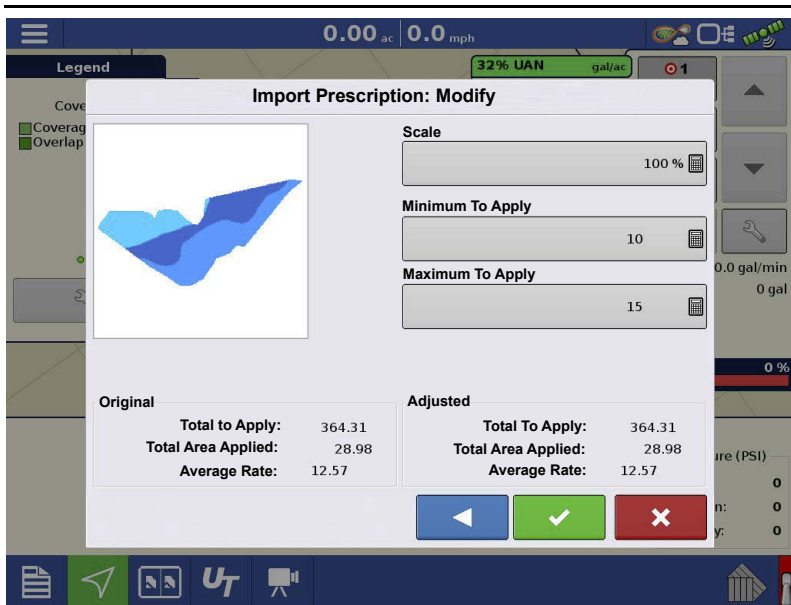

5. In the Modify Prescription Screen the prescription scale, minimum to apply, and maximum to apply can be changed. As the three parameters are changed, the adjusted total to apply and average rate will update accordingly.

6. Press the .

7. After returning to the Mapping Screen, the prescription will appear on

the map while in a North Oriented view.

## Shape File Conversion

What is commonly called a shape file is actually a collection of three different files. All three of the files are required and must be present on the USB drive for the system to use shape file groups for variable rate product application. A single "shape file" can contain recommendation rates for multiple products.

1. To begin, press  on the Product Control Toolbox.

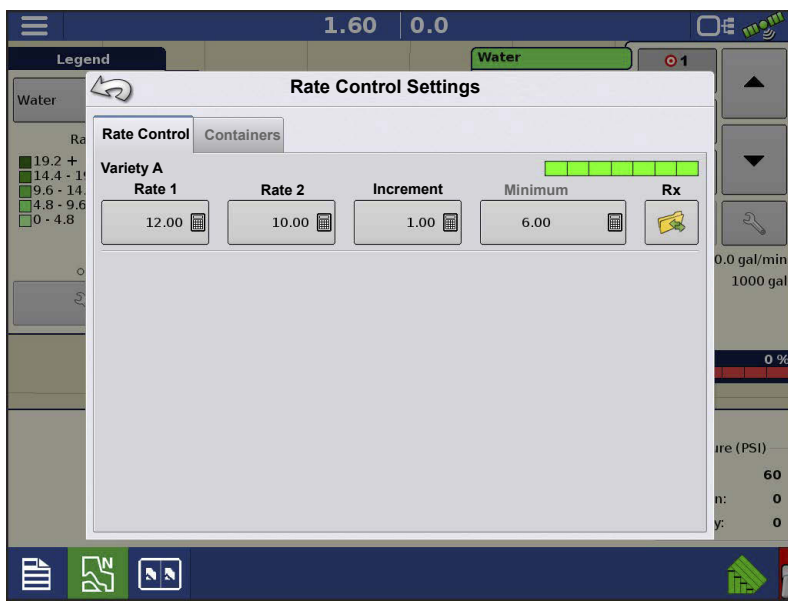

The Rate Control Settings screen appears

2. Press the Load Prescription button.

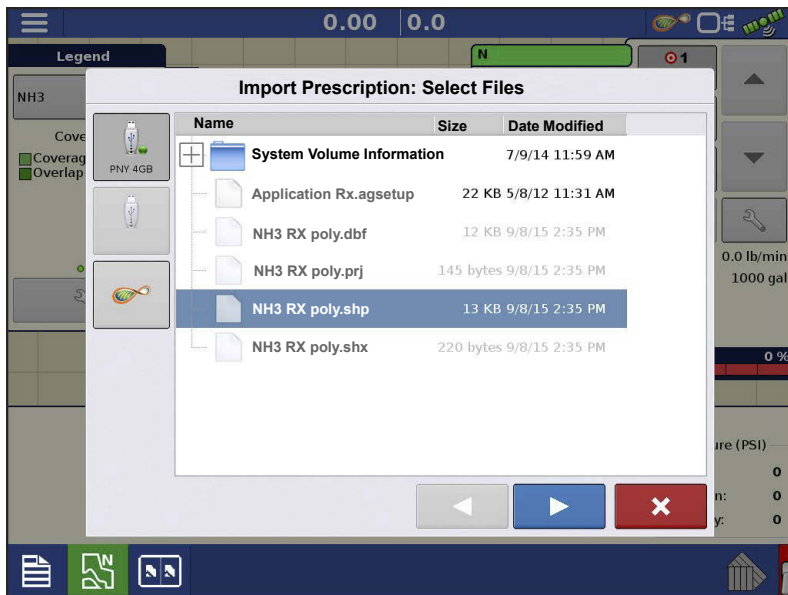

3. The Select File screen appears.

Highlight your desired .shp file and press .

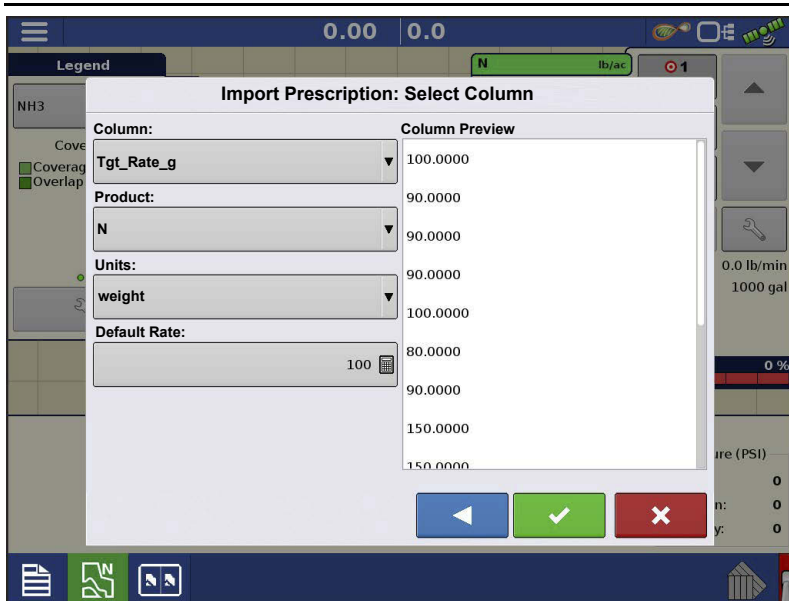

#### 4. Select Column From Shape File

Select the column that contains the product recommendation rate. The list on the right side of the dialog shows sample data from the selected column.

#### 5. Select Units

Select the controlling units for product application.

#### 6. Default Rate Setting

The system assigns a default rate. Use the on-screen keypad to edit the value if desired.



**NOTE!:** Select the product and units that the shape file prescription was made for. Selection of the wrong data column or unit will result in misapplication of product.



**ATTENTION!:** The only time the default rate is used by the system during product application is if the Rate Outside of Field selection is set to "Rx default". This setting is located in the equipment configuration settings portion of configuration setup. If the Rate Outside of Field selection is set to "Rx default", the default target rate will be used when the vehicle exits the area covered in the prescription map.

## Creating Products

Creating application products and product templates can be completed during initial setup or from the Product Selection screen of the Field Operation Wizard when starting a field operation.

### Creating Single Products

To create a single product, to be added to a product template or to be applied by itself, use the on-screen wizard described in the following steps.





Select:

1. Product Type
2. Product Units
3. EPA Product Number (Optional)

Check box if product is a Restricted Use Pesticide

4. Manufacturer name if applicable.

Manufacturer name can be added to the drop-down menu by pressing .

5. Press  to enter a unique name for the product.

Created product should appear under the Application heading located on the Product tab of the Configuration Setup screen.



**NOTE!:** Some Fertilizer and Carrier product types are predetermined in the display. These product names cannot be edited. Their Manufacturer and EPA Numbers can be edited after the product is created. Examples are: Fertilizer>DAP or Carrier>30% UAN.

## Creating Product Template

Product Templates are set up by using the on-screen wizard.



**NOTE!:** Prior to making a new product template, it is recommended to add the individual products to the list in the units recommended by the chemical label.

It is recommended to create product templates that contain the products applied for a crop type or time of the season.

Examples are:

- Pre-Emerge Burndown
- Post-Emerge Corn
- Post-Emerge Beans
- Insecticide



- Fungicide

In each template the products can be checked on/off for the mix when loaded at the run screen.



## 6. Select Tank Mix

Define By

- Total amounts—mix/blend defined by amounts added to the tank (total of each product in tank)
- Rate/acre—mix/blend defined by the amounts applied per acre (rate of each product applied/area)

## 7. Enter a Base Amount or Base Rate and Units.

- Total Amounts—Tank/Bin Size
- Rate/Acre—For Rate Applied per Acre



## 8. Select Carrier

- Press  to create a new carrier.

## 9. Press by the Add Mix/Blend Contents box to start the process of adding components to the mix.

## 10. Select the desired component from the drop-down menu.

 **NOTE!:** More than 7 products can be part of a template, but only 7 or fewer can be active at the same time.

- A new product can be set up at this time by pressing  and following the Product Setup Wizard.
- Press  to add selected product, or press  to return to Add Mix/Blend screen without adding a product.

## 11. Press to add an additional product.



---

12. When all components have been added press .

13. Enter Manufacturer name is applicable.

- Manufacturer name can be added to the drop-down menu by pressing .

14. Press  to enter a unique name for the mix/blend.

- Press  to complete the process of setting up the mix/blend, or press  to return to the Configuration Setup screen without adding a mix.

The product mix/blend appears under the Application heading located on the Product tab of the Configuration Setup screen.



Represents Product Templates

## Configure Product Mix

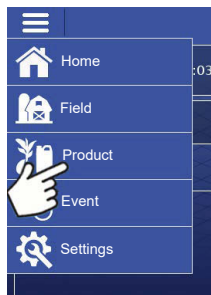

When using a product template, the mix contents and amounts are defined in the Configure Product Mix screen available in the Event Setup Wizard, or Product button in the main menu.

# ISO Liquid Rate Control

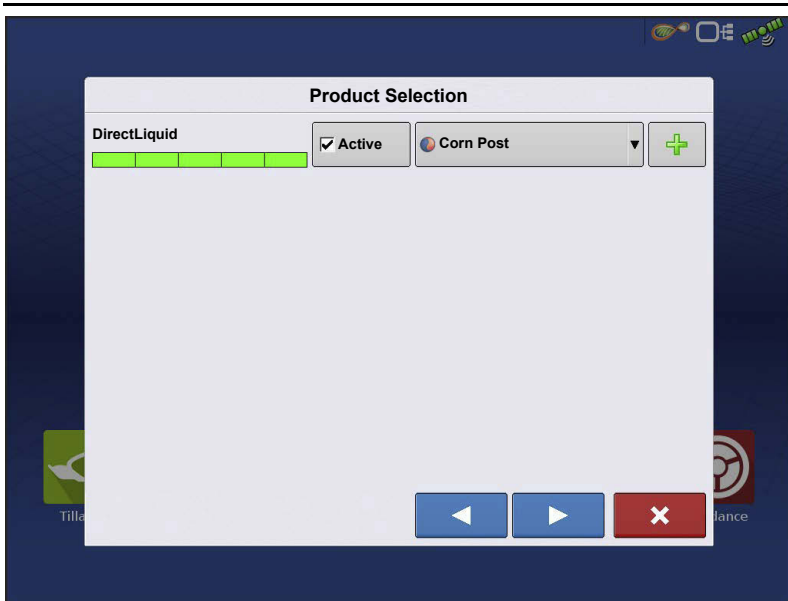

1. Select your mix/blend from the drop-down list or press  to create and new mix/blend.

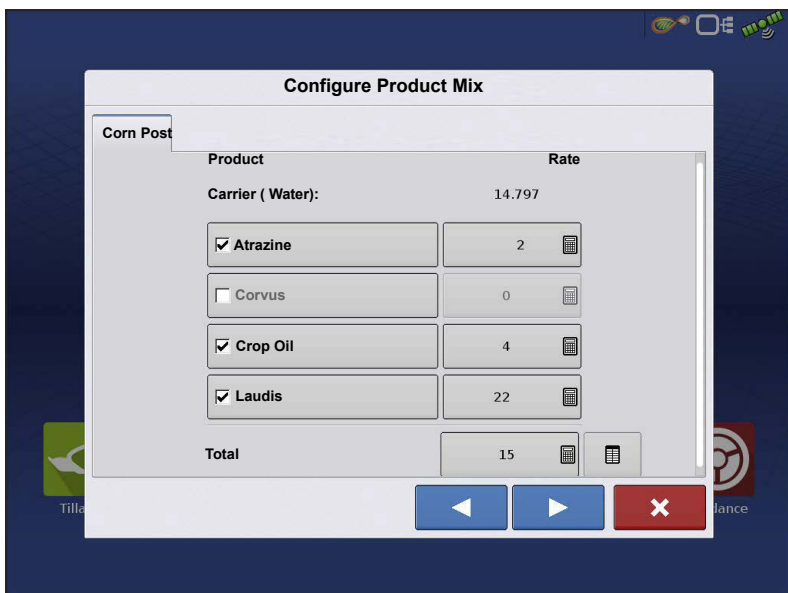

2. The product template mix contents and amounts are defined by:

- a. activating or de-activating products
  - b. changing rate or total amount of product
  - c. changing total amount of the product or overall rate of product application
- A product can not be active with a rate

of zero. Press  to access the Mix Calculator.

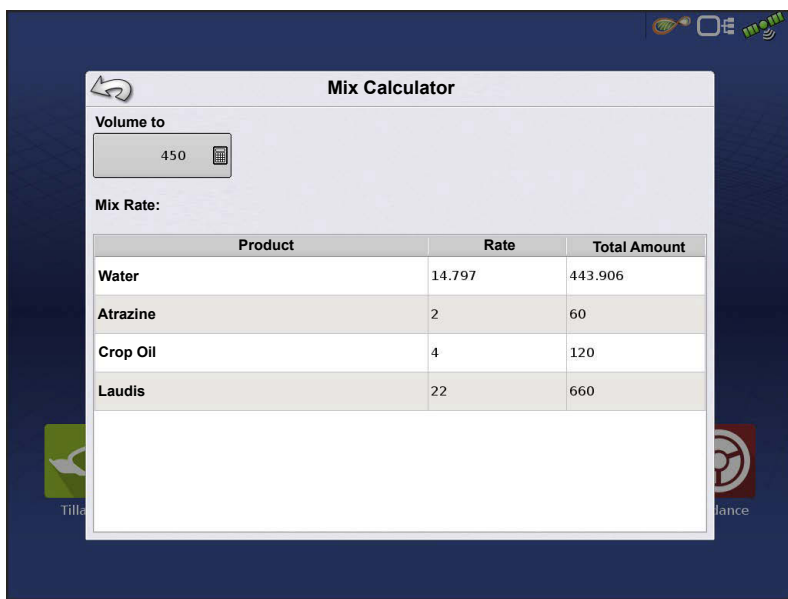

3. When a product template is setup using rate/area, the Mix Calculator can be used to show how much of each product to put in the tank when the user enters the desired amount to fill.

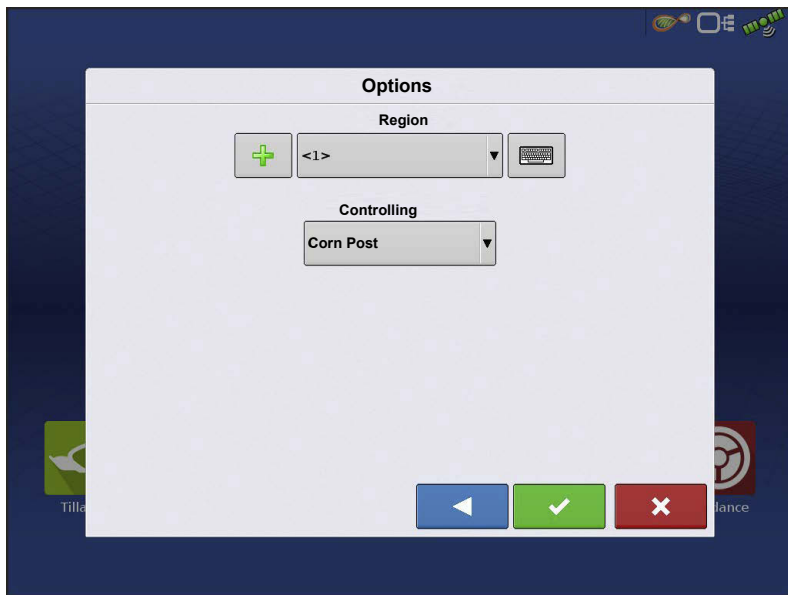

4. Press the Volume to Calculate button and input the total volume. Table will give the user the amount of each product to put in the tank.



5. Select Region from the drop-down menu or press  to name Region. Verify the Controlling Product for the Mix/Blend.

Press  to load the Event to the Map Screen, or press  to return to Home screen without setting up an Event.

## Create Configuration

A wizard will guide you through the process of selecting or creating a configuration with application settings.

The configuration can be started in two places:



OR

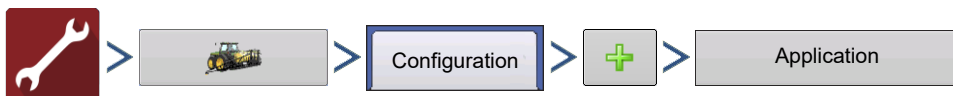

Your Operating Configuration will then be viewable when you start a new Field Operation with the Application Wizard.

You can also use the **Manage Equipment** button to create or edit specific vehicles and implements.

## Implement Offsets

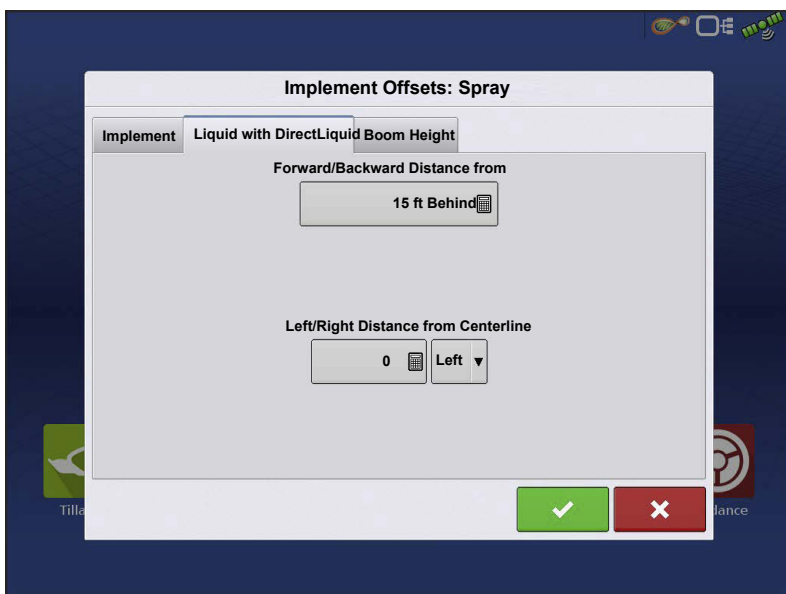
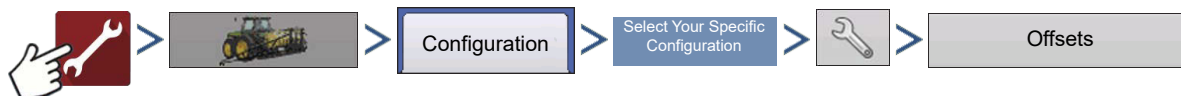

Implement Offsets screen appears, with each channel's settings shown on its own tab.

Defaults to the value entered during Configuration Wizard

Boom sections can independently be offset forward or back (application only)

Press  to access Swath Section Offsets screen.

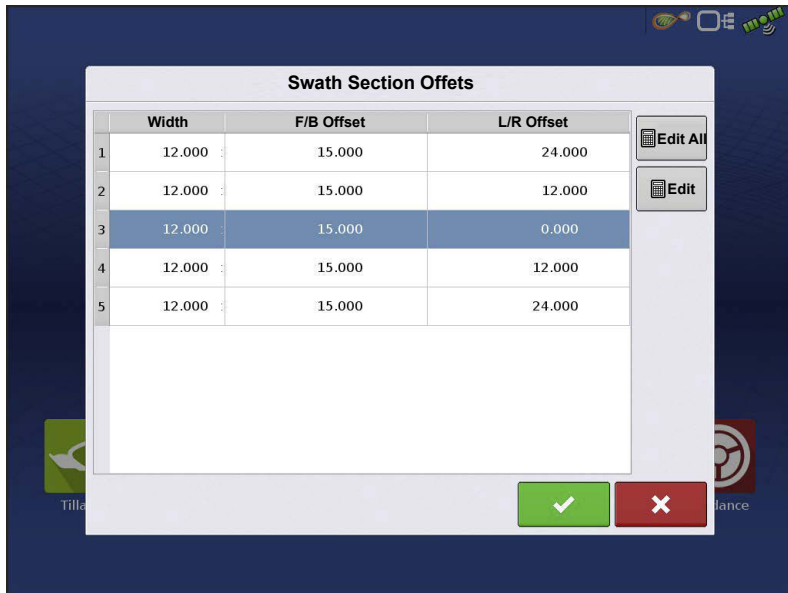

Select Swath section to edit and press Edit button.

Enter Offset for that specific section and Forward/Backward from rear axle.

Press  to enter change.

Setup will indicate which offset is entered

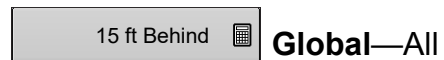

sections have the same offset.

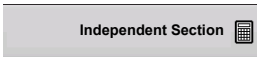

**Individual**—At least one section has a different offset.

Runscreen reflects section offsets

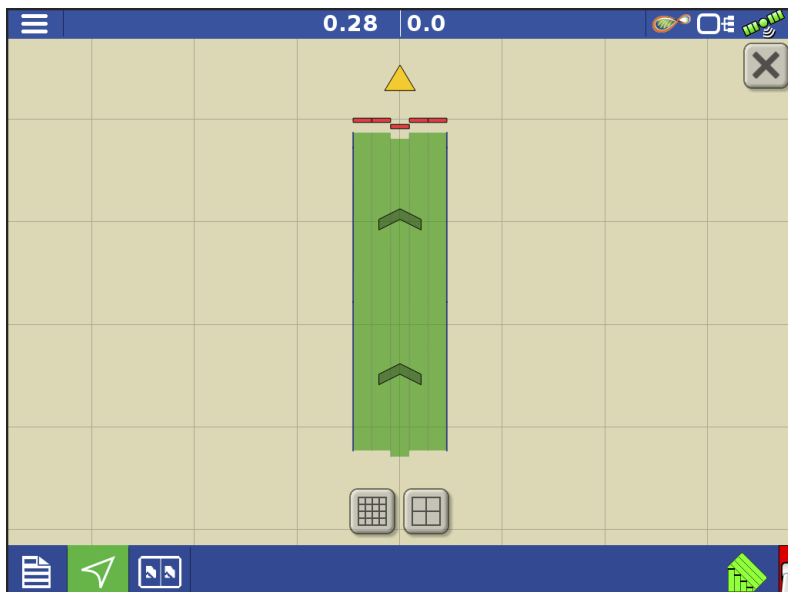

## Hardi Safe Track

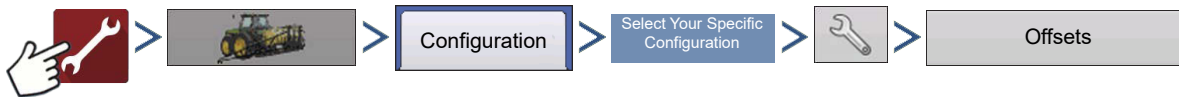

When using Hardi ISOBUS, Implement Modeling can be set to Hardi SafeTrack. This allows display to accurately calculate path of sprayer. Hardi SafeTrack Modeling is utilized by the display when SafeTrack is engaged on the machine.

**NOTE!** When a Hardi ECU is present and SafeTrack is in use, the Heading Aggressiveness will be

grayed out in the Implement Offsets screen. The Heading Aggressiveness will need to be adjusted from the Hardi interface.

If a trailed implement utilizes a steerable axle, the Hardi SafeTrack feature can be used without a Hardi ECU. This will allow manual adjustment of the Heading Aggressiveness from the Implement Offsets screen.

- **Heading Aggressiveness**

The Heading Aggressiveness setting can be used to fine tune mapping of a trailed implement. (Example: Pull type sprayer that has a steerable axle feature) The setting ranges from 0 - 10. The default value is 2.

An aggressiveness setting near 0 or 1 will model similar to an implement that has a rigid axle. With the only pivot point being the implement's attachment at the vehicle's hitch.

As the aggressiveness setting is increased, the modeling will start to resemble an implement that "follows" the path of the vehicle. The modeling will become more exaggerated the closer the setting is to 9 or 10.

# UT Runscreen

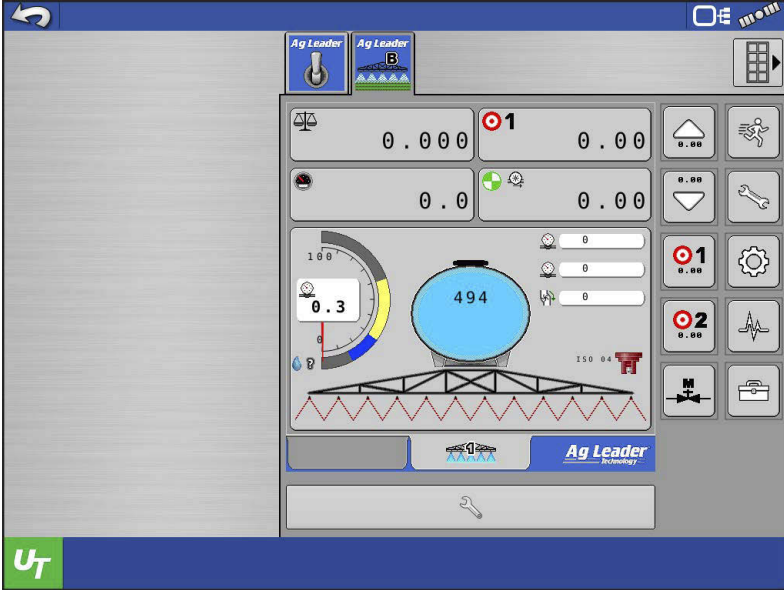

The runscreen has 4 readouts that will be presented regardless of the system type.

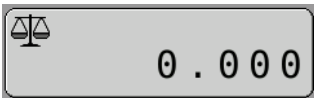

Product Density



Rate Control Settings



Speed Source Settings



Actual Rate Settings



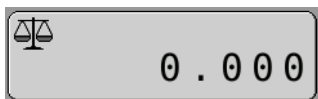
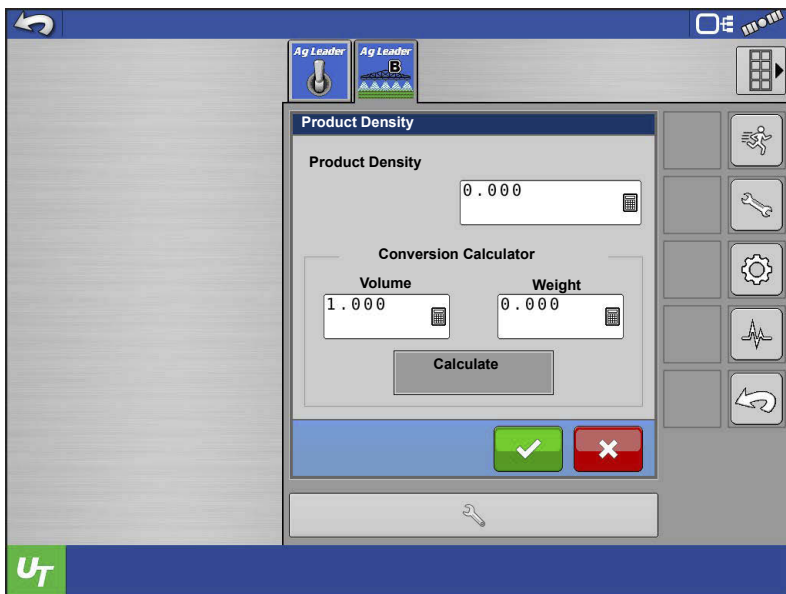

## Product Density

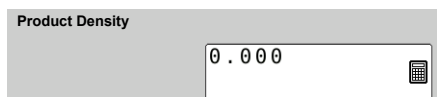

This displays the current product density. If connected to an Ag Leader display with an event loaded, this will need to be set on the map screen under settings.

To enter a product density:

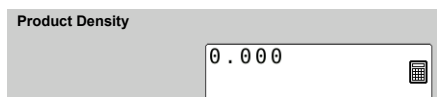

1. Press .
2. Enter value.
3. Press  to save or  to cancel.



**NOTE!:** The density can be calculated if the volume and weight of the product is known.

Enter both values into the Conversion Calculator and press

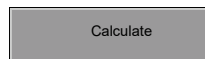

**NOTE!:** Product density is disabled when an NH3 system is active.

## Rate Control Settings



Rate Control Settings is where Target Rate 1 and 2 are set, as well as the increment value.

Enter each value and press  to save or  to cancel.



**NOTE!:** An Anhydrous Ammonia system will also allow the user to define the controlling units as either lbs of N/ac, lbs of NH<sub>3</sub>/ac, or gallons/ac.

## Speed Source Settings

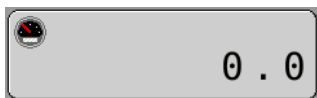
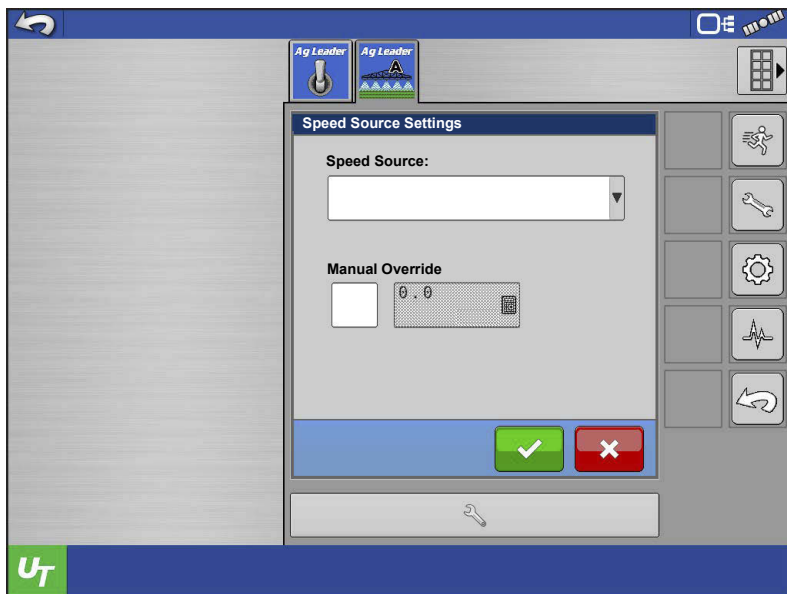

This is where the user defines the speed source. The user can choose from the options below.

**ISO GBSD**—Ground Based Speed and Direction from a GPS source (ISO11783). Message is received on the ISO CAN bus.

**ISO WBSD**—Wheel Based Speed and Direction from a tractor ECU typically, could be radar (ISO11783). Message is received on the ISO CAN bus.

**Module Wheel Speed**—Module wheel speed input source. Wheel speed sensor on the implement.

**CAN GPS**—NMEA 2000 CAN GPS source. Could be direct from a GPS receiver or other ECU. Message is received on the ISO CAN bus.



**Machine Selected Speed**—Speed source supplied from the vehicle ECU. This speed source is determined by the vehicle ECU as the best available speed source and sent on the ISO CAN bus (i.e. GPS, Wheel, Radar). Not all vehicle ECU's will have this type of speed message available.

Select the desired speed source from the combo box.

---

To set a **Manual Override** speed:

- a. Check **Manual Override** checkbox
- b. Enter desired speed in input box

Press  to save or  to cancel.

## Auxiliary Speed Source

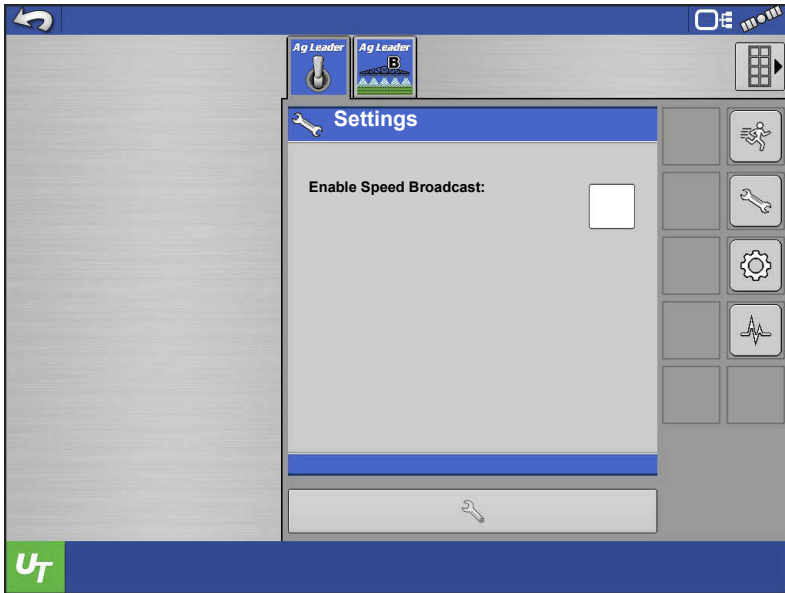

Allows user to input auxiliary speed source such as radar via ISO switchbox.

 **NOTE!:** Improperly selecting this will cause 0 speed on Universal Terminal.

## Actual Rate Settings

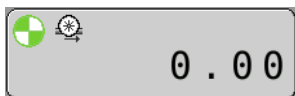
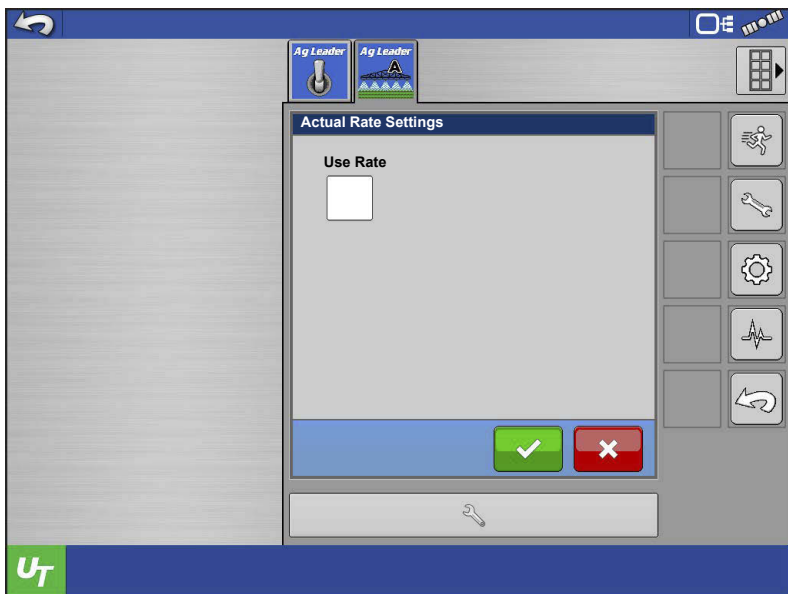

The Actual Rate Settings is where the user turns Rate Smoothing on and off.

- Check this setting to smooth the displayed actual rate by 10%.
- Uncheck this setting to display the actual rate the flow sensor is reporting.

## System Settings screen

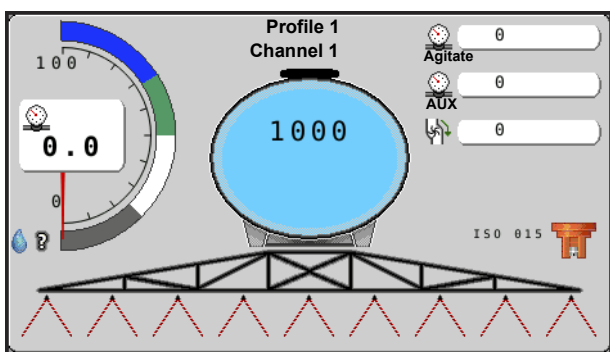

This screen displays information about the implement.

# Universal Pressure Sensor

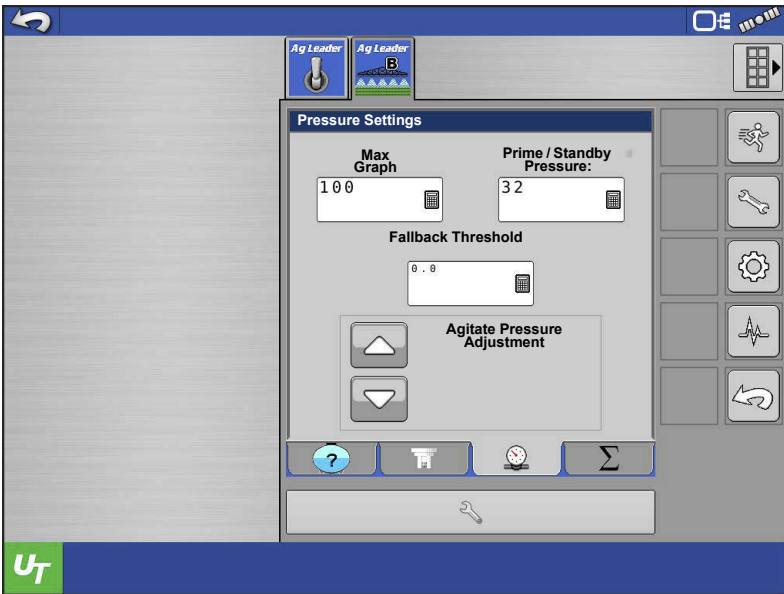
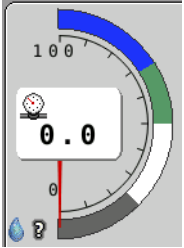

It displays the Universal Pressure sensor and Droplet Size indicator.

This will display the current pressure read out from pressure sensor one. If a pressure sensor is not present the module will calculate the system pressure. A nozzle must be defined and selected for this.

It will also display the droplet size ranges for the selected nozzle. A nozzle must be defined and selected

for this to be present.

Pressing the Universal Pressure gauge will take the user to the Pressure Settings

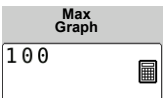

•**Max graph Pressure**—The user can define the range the Universal pressure gauge displays. The max is 250 psi (17 bar).

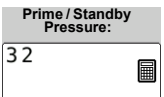

•**Prime/Standby Pressure**—The user can set the desired psi or bar for the system to hold when priming the system or when all sections are off.



**ATTENTION!:** When Prime or Standby Pressure is in use, the module will first control at the PWM Standby setting. After it achieves the PWM Standby duty cycle, the module will then attempt to hold the Prime/Standby Pressure. PWM Standby will need to be set appropriately to closely match the desired Prime/Standby Pressure. If the Prime/Standby Pressure cannot be achieved, the control module will time-out. See [PWM Settings Tool](#) on [page 683](#) to set the PWM Standby appropriately.

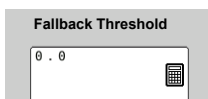

• **Fallback Threshold**—The user can set the range of flow that the system will switch between flow based control or pressure based control. For example, setting the threshold to 10 gal/min will result in the system using the flow meter when flow is >10 gal/min and using the pressure sensor when flow is <10 gal/min.



**NOTE!:** Fallback Threshold is only available if the pressure fallback setting was checked when creating the profile.

## Vapor State Monitoring

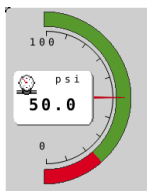

- When an Anhydrous Ammonia system is setup, NH3 state monitoring is capable. In order to use the on screen gauge for NH3 state monitoring, a temperature sensor and main line pressure sensor must both be installed and calibrated. Once both sensors are installed and calibrated, the UT pressure gauge will now display only RED and GREEN portions.
- When the UT pressure gauge needle is in the GREEN area, this indicates that the NH3 is being applied in a liquid state.
- When the UT pressure gauge needle is in the RED area, this indicates that the NH3 is being applied in a vapor state.

## Pressure, Temperature, and RPM readings

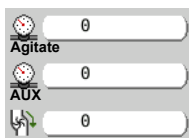

System Settings screen also displays Agitate and Aux pressure, as well as Pump RPM. These will only display a readout if the sensor is present on the system, and is calibrated.

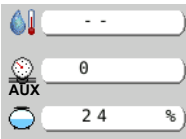

An Anhydrous Ammonia system will display Temperature, Aux Pressure, and the remaining tank percentage. Temperature and Aux Pressure require a sensor in order to provide a read out.

## Tank Capacity

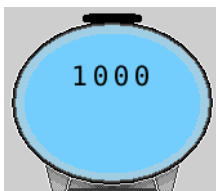

The tank capacity indicator will display the remaining tank volume. Pressing the tank capacity indicator will take the user to Container Settings screen.

## Fill, Set, or Empty Tank



Pressing fill will fill the tank to its full capacity.





Pressing set will allow the user to enter a specific volume that is not completely full or empty.



Pressing empty will remove all volume from the tank.

## Container Alarms

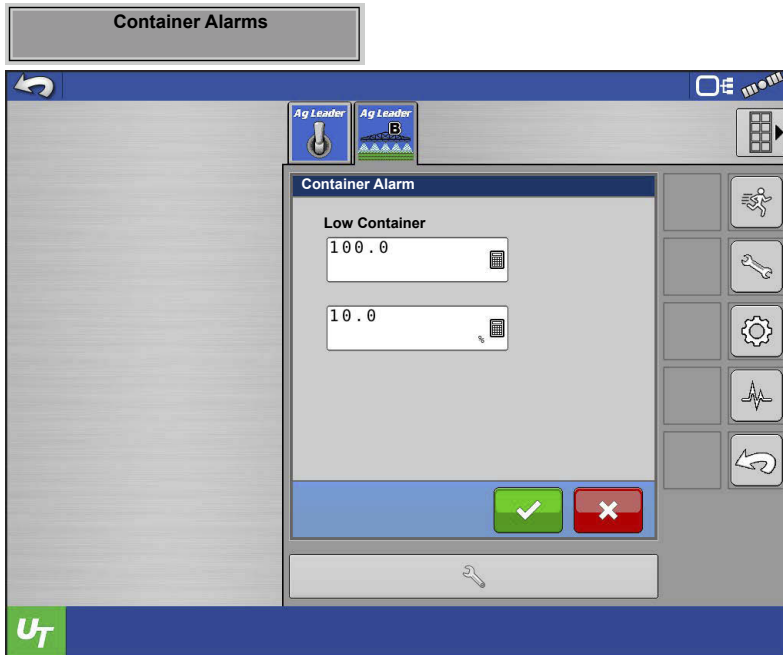

Pressing Container Alarms will allow the user to set the alarm threshold by either an amount of volume or by a percentage of the tank capacity.

## NH3 Tank Capacity

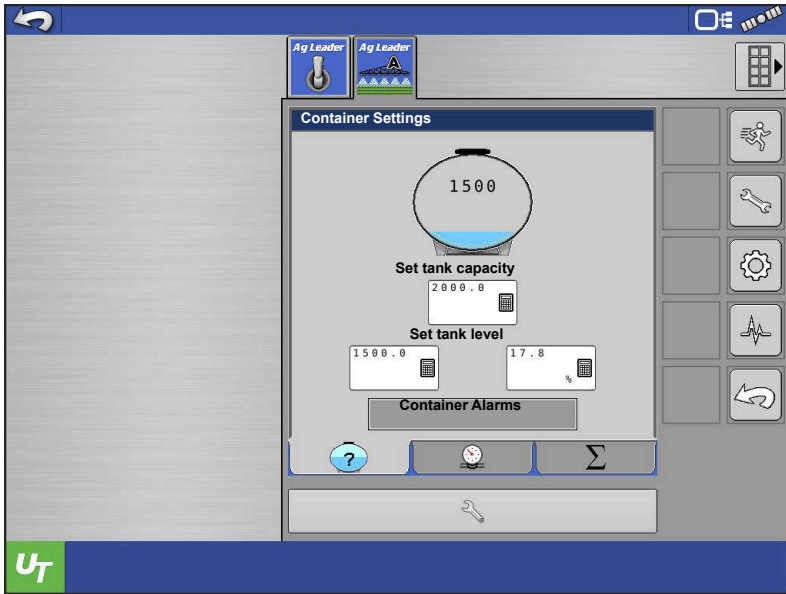

When an Anhydrous Ammonia system is active the user gets a few more options with the tank capacity. NH3 tanks size vary depending on where the user gets them from or what's available. Because of this the user can redefine the tank capacity at any time. The user can also set the remaining capacity based on the controlling units or by a percentage. The user could tell the system there are 1500 lbs of N left

in the tank or 17.8% left in the tank.

## Nozzles

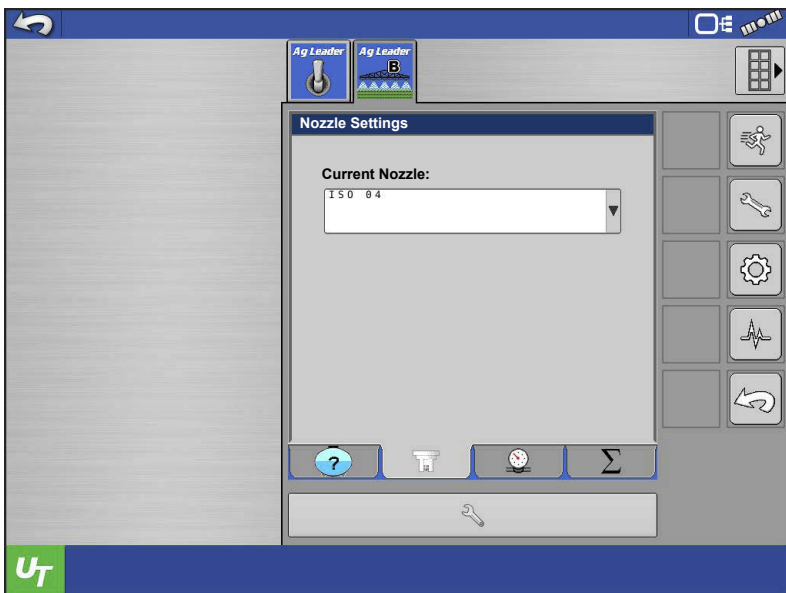

The user can change nozzle by pressing the nozzle indicator. Select the current nozzle, that is present on the machine, from the available options.

## Section Indicators

The section indicators show the application state of each section on the sprayer.

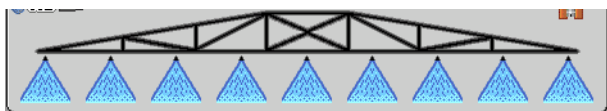

Applying

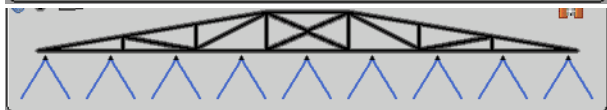

Not applying due to AutoSwath

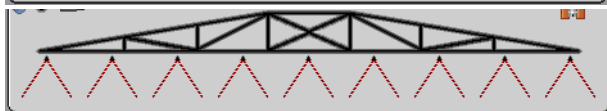

Not applying due to switches off

Toolbar section indicators are shown below:



Applying



Not applying due to AutoSwath



Not applying due to switches off

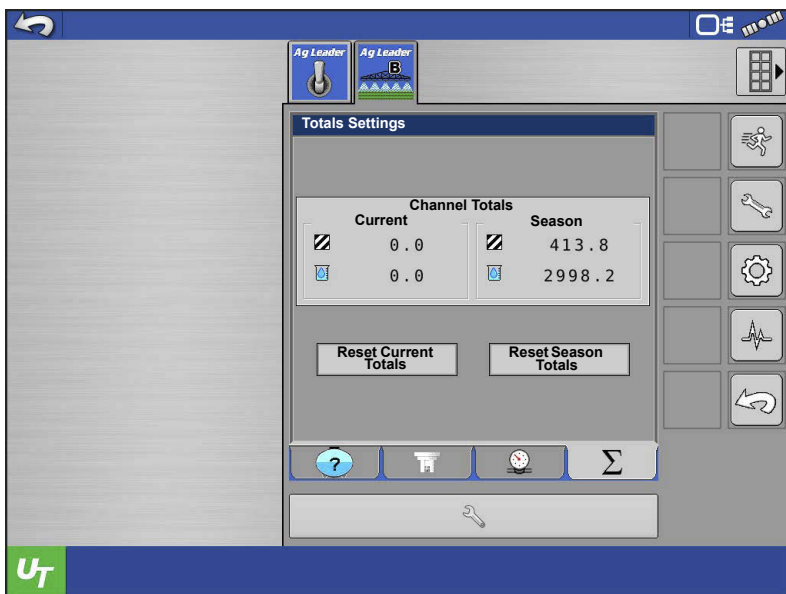

Pressing the section indicators will take the user to the Totals settings

Totals Settings shows the user the total area covered and product applied for the entire season or current event. Each can be reset at any time.



**NOTE!:** If connected to an Ag Leader display, the current totals will reset with each new event created.

---

## Manage Components

Manage Components is used to create machine profiles and nozzles.

### Profiles

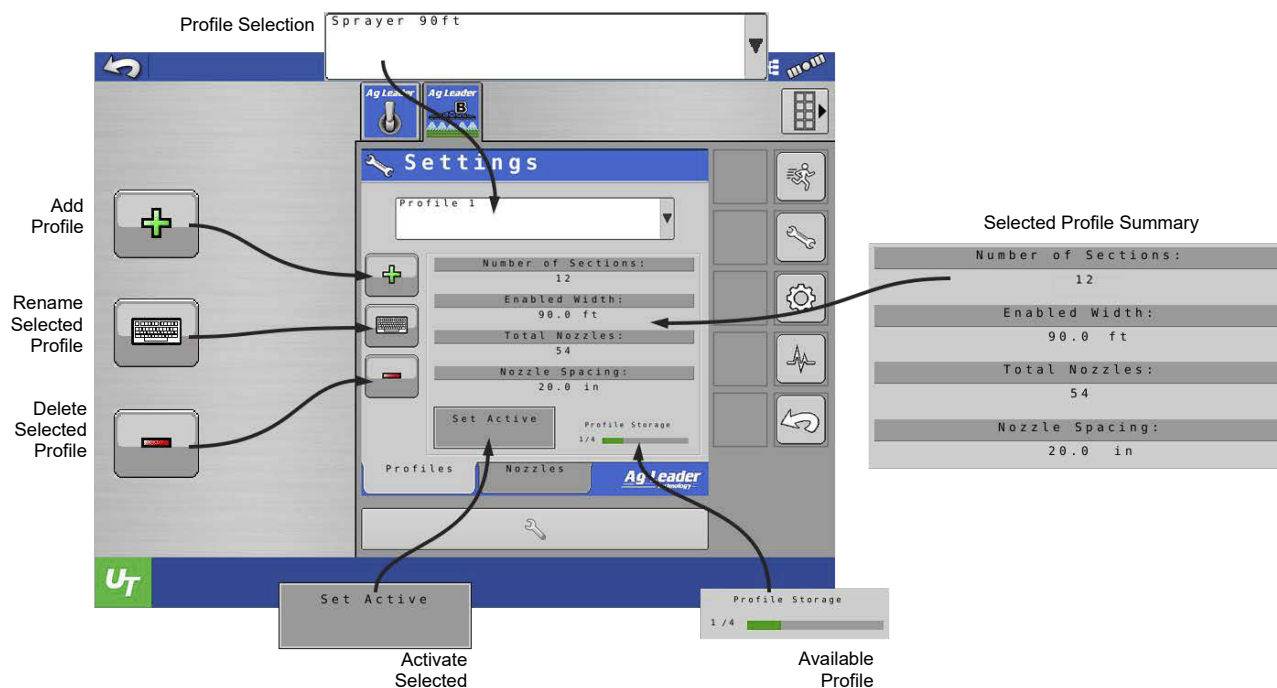



Creating machine profiles is useful when there is more than one possible configuration of the same machine. For example, if a user sprays with the entire 120ft boom of their sprayer on one field. On the next field they fold in their extensions to only spray using 90ft of the swath width. Creating a profile for each scenario will prevent accidental activation of sections that are folded causing over application. Each system can have up to 4 profiles saved.

### Add Profile

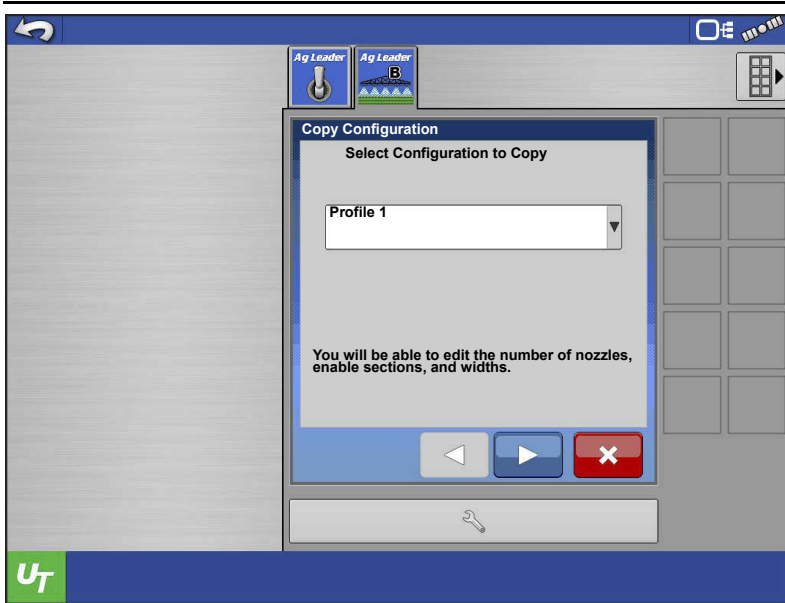

# ISO Liquid Rate Control



1. Select a configuration to copy for the base of your profile. Press  to continue.

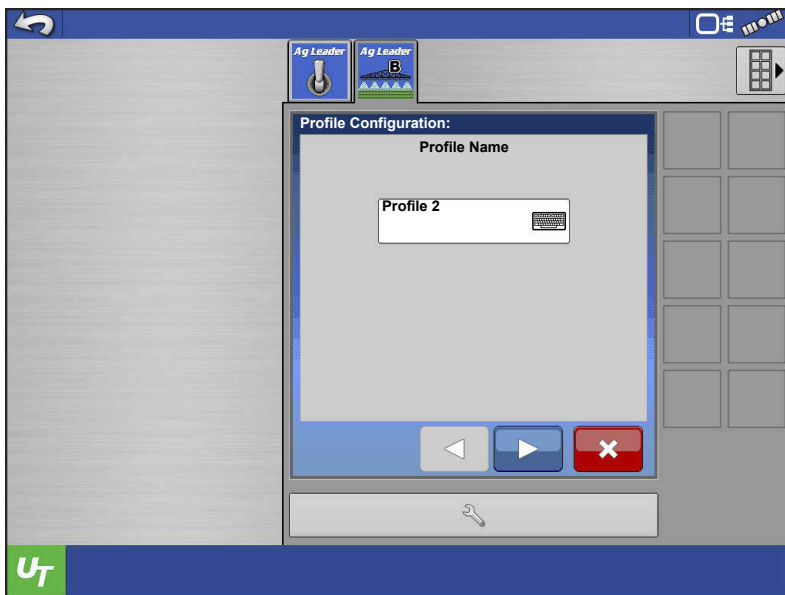

2. Name the Profile. Press  to continue.

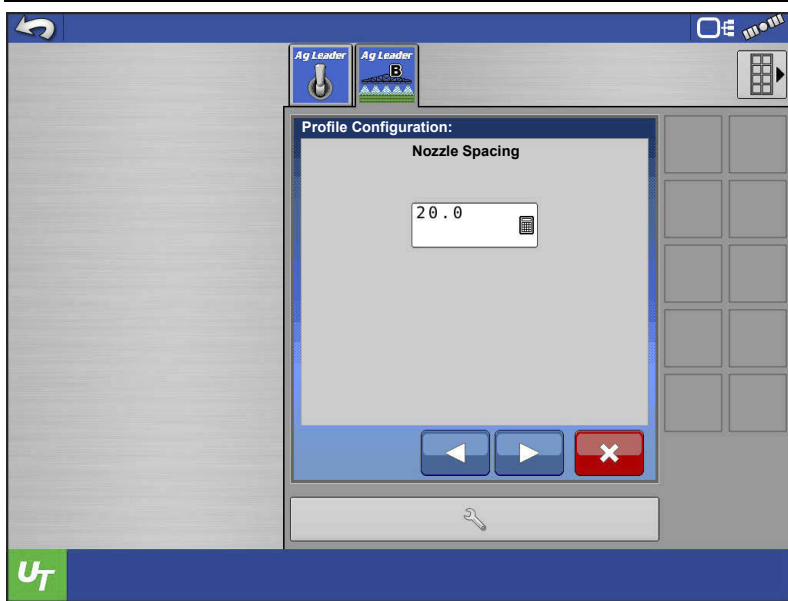

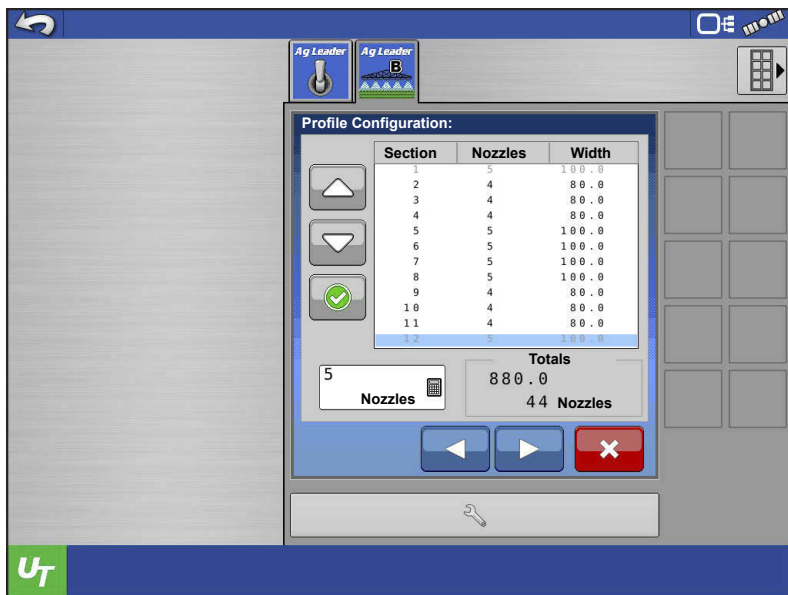

3. Enter the Nozzle Spacing. Press

 to continue.



4. Enter the number of nozzles for each section.

Use  and  to select sections.

Use  to disable sections that won't be used in this profile.

5. Verify that the swath and number of nozzles are correct.

6. Press  to continue.

# ISO Liquid Rate Control

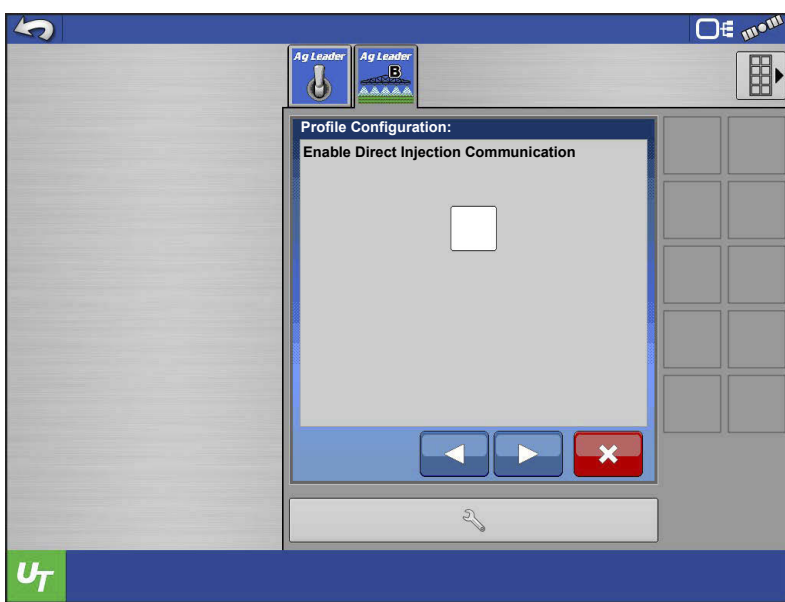

7. Place a checkmark in the box to enable Direct Injection Communication if a Raven ISO Injection Pump will be used. If one will not be used do not place a check mark in the box. Press  to continue.

 **NOTE!:** This is only used for Raven ISO Injection Pump.

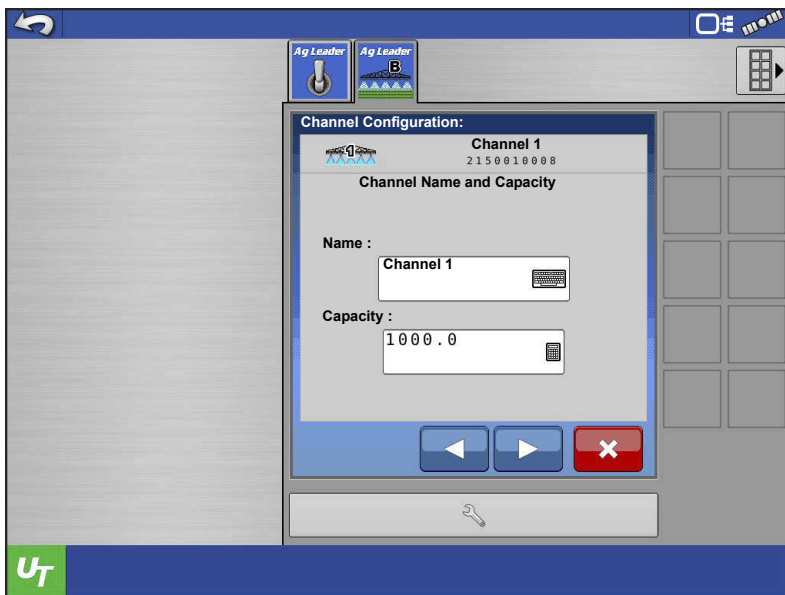

8. Name the channel and enter the tank capacity. Press  to continue.

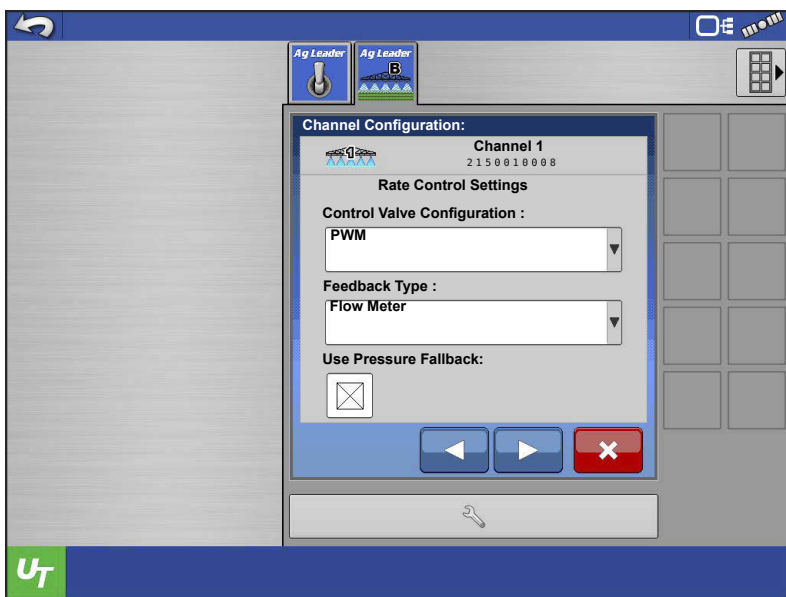

9. Select the Control Valve Configuration based on what is present on the vehicle.

10. Select the Feedback Type. This will determine if the system controls the rate using flow based control or pressure based control.

- Select Flow Meter for flow based control. A flow meter must be present on the machine.

- Select Pressure Sensor for pressure based control. A main pressure sensor must be present on the machine.

11. Place a check mark in the box to use Pressure Fallback, otherwise leave the box unchecked. Pressure Fallback is a setting that allows the system to automatically switch between flow based and pressure based control. It is very useful in low flow situations where a flow meter may not be accurate enough to read low flow rates. In that situation the system will activate Pressure Fallback (based on a user defined threshold) and switch from flow based control to pressure based control. Both a flow meter and a pressure sensor must be present on the machine to use Pressure Fallback.

Press  to continue.



12. Select the behavior for Aux Valve 1, 2, and the Control Valve.

- Selecting Closed or Open for Aux Valve 1 and 2, determines what state each valve enters when all sections are turned off

13. Selecting Hold or Closed for the Control Valve behavior determines what state the control valve enters when all sections turn off.



- **Hold**—The control valve will hold the last known rate when all sections turn off.



**NOTE!** When using a PWM control valve the option will change to Maintain Standby Pressure. With this setting the control valve will maintain the user defined standby pressure when all sections are off.

- **Close**—The control valve will close when all sections turn off. This is useful on implements that don't utilize boom sections or only have a single section, such as NH3 Toolbars or Liquid Manure Tankers.

14. Once all behaviors have been selected, press  to continue.

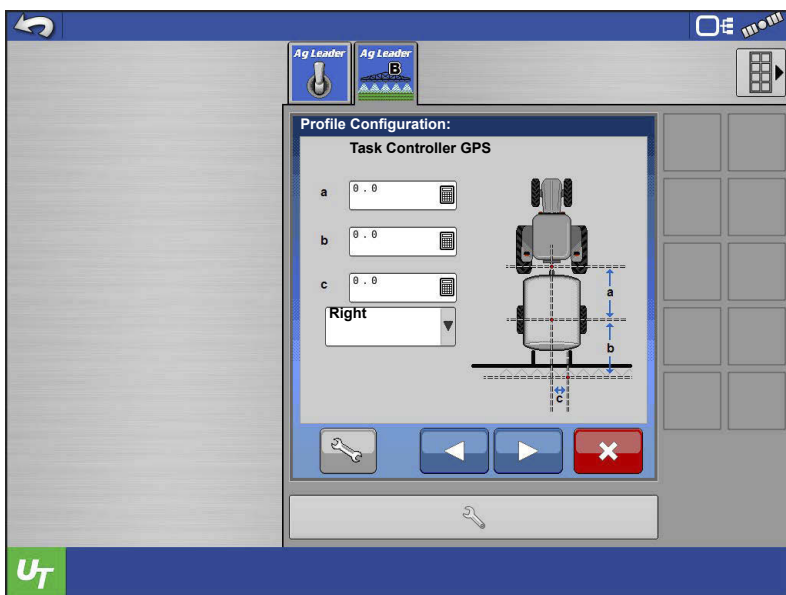

15. Enter the depicted GPS Offsets in inches.

Press .

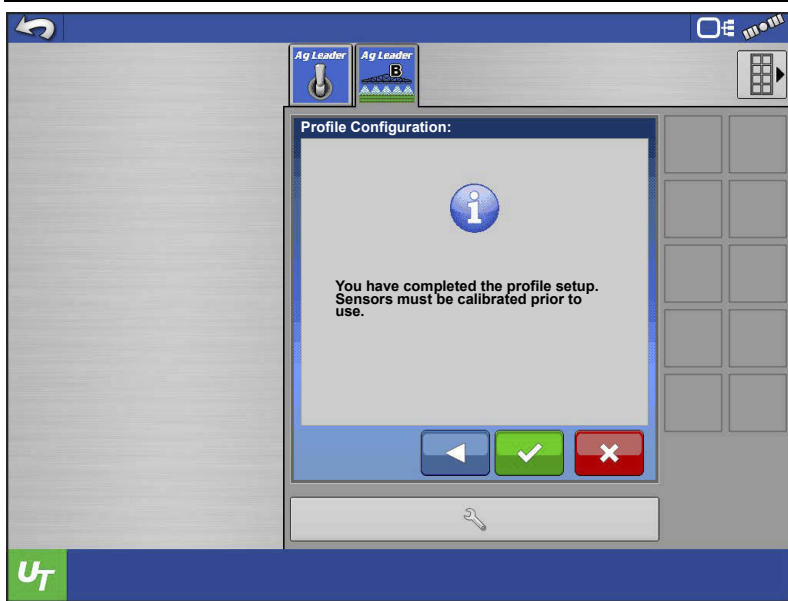

16. Profile Setup is now complete.

Press .

 **NOTE!** The module will have to reboot to save the configuration.

Press .

## Delete Profile





Use the Profile Selection box to select the profile you wish to delete.

Once the profile is displayed in the box, press .

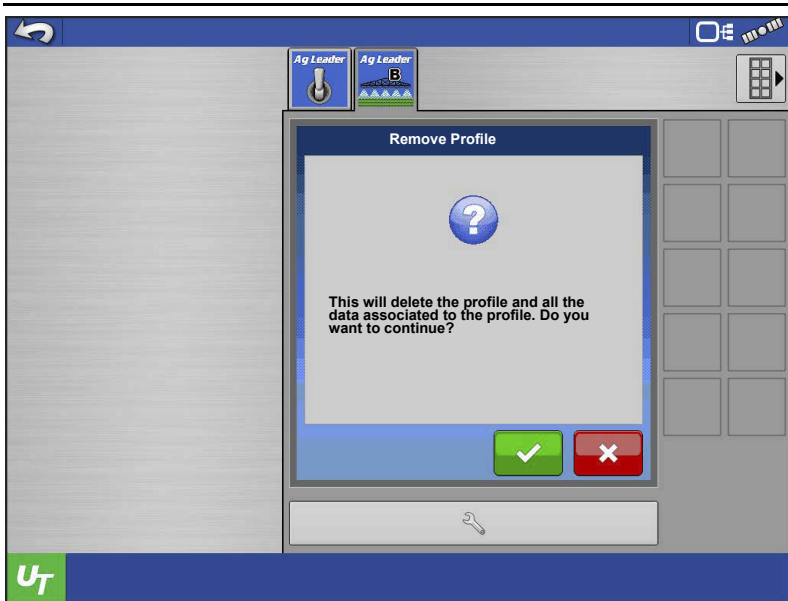

 **NOTE!** The active profile cannot be deleted. In the instance that all profiles are desired to be deleted, use the Reset Function. See System Settings.

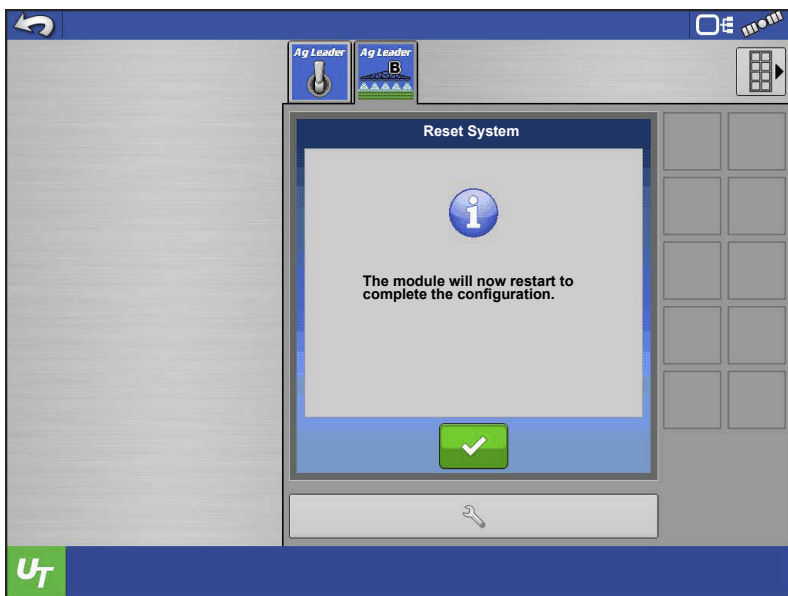

To confirm deleting the profile, press . To cancel deleting the profile, press .

## Set Active Profile



1. Select the profile to be set active from the Profile Selection and then press .
2. The module will have to reboot to activate the profile. Press .
3. When the module reboots, the profile should be active.

# Nozzles

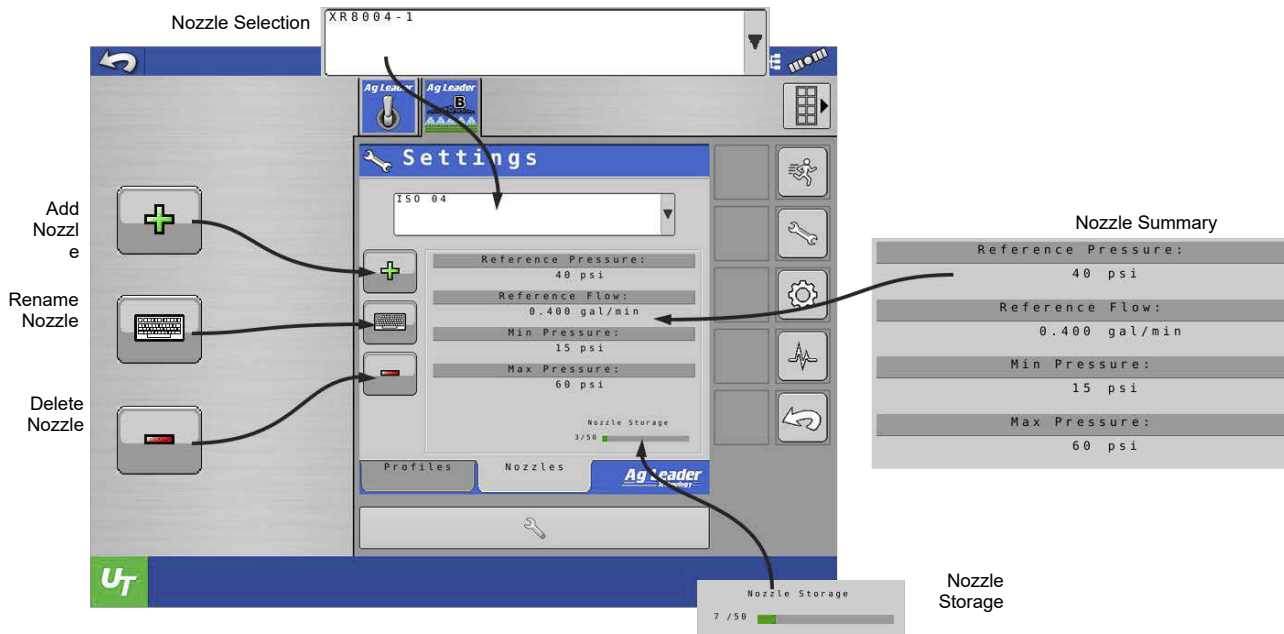

Creating nozzles is required for pressure based control, pressure fall-back, and droplet size monitoring. A nozzle's specifications are needed to achieve each feature.



**NOTE!:** Nozzles within Manage Components is only useful for creating and defining nozzles. A user will not set active nozzles here as they would with profiles. Active nozzles are selected on the runscreen.



## Add Nozzle

Select a Nozzle Creation Method.

- **Select All Parameters manually**—This allows the user to create a new nozzle and enter in all of the nozzle specifications from a tip chart.
- **Select an ISO Nozzle**—There are 11 preloaded ISO nozzles entered with all required specifications already entered.

Press .



**NOTE!:** Pressure thresholds and Droplet size thresholds will still need to be defined.

- **Select a Previously Created Nozzle**—This allows the user to copy a previously created nozzle and modify it. This helps when creating nozzles with similar specifications.

Enter the nozzle Name, Reference Pressure, Reference Flow, Min Pressure, and Max pressure.

Press .

- **Reference Pressure**—One of the pressures listed for the nozzle on the tip chart. Recommend closest pressure to desired target rate and speed.
- **Reference Flow**—Corresponding flow to the selected reference pressure.
- **Min Pressure**—The minimum pressure the system will achieve when this nozzle is selected.
- **Max Pressure**—The maximum pressure the system will achieve when this nozzle is selected.



**NOTE!:** Reference Pressure, Reference Flow, and Min Pressure are required for Minimum Flow and are required even if a pressure sensor is NOT installed.

Enter the base pressure for each droplet size supported by this nozzle. Press .



**NOTE!:** Use a tip chart to find these values. If a droplet size is not achievable with a nozzle leave the psi value blank. Only droplets with psi values entered will be displayed on the digital pressure gauge.

Select the nozzle color. Press  to save and finish.

## Delete Nozzle



Use the Nozzle Selection box to select the nozzle you wish to delete.

Press .

To confirm deleting the nozzle, press . To cancel deleting the nozzle, press .

## Controller Settings

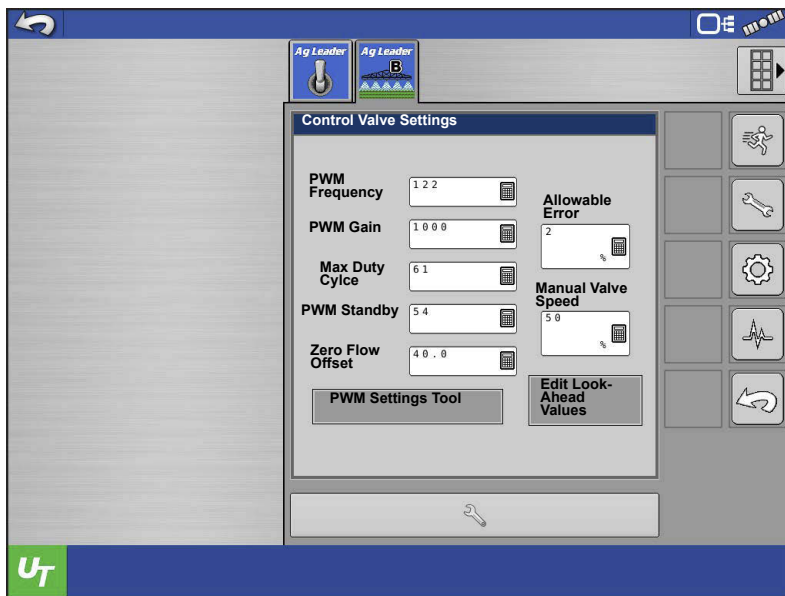

### Control Valve Settings

This Control Valve Settings screen will be provided for profiles setup with the control valve types listed below.

- PWM 12 Volt
- PWM Ground



**NOTE!** If these settings show

up and you do not have one of the listed control valves, verify the correct profile is selected. If the correct profile is active, the profile needs reconfigured.

- **PWM Frequency**—The frequency that the PWM control valve is pulsed at. Settings can be found from the manufacturer of the valve. Typical settings range from 100-125 Hz.
- **PWM Gain**—Determines how aggressively the control valve responds when making rate change adjustments. The higher the value the more aggressive the system response is.
- **Max Duty Cycle**—The maximum percent duty cycle the valve is allowed to achieve. The valve will not be allowed to achieve a higher duty cycle than the valve entered.
- **PWM Standby**—This is a user-defined setting that determines the percent duty cycle the system uses when the booms are all off. The setting must be greater than the Zero Flow Offset.
- **Zero Flow Offset**—The maximum duty cycle that is sent to the control valve without producing any hydraulic flow from the PWM valve. Using too high of a Zero Flow Offset value can cause the product control system to not properly control low rates. See the PWM valve manufacturer information for recommended settings.
- **Allowable Error**—The percent of error that is allowed prior to the product control system making any flow rate changes.

- **Manual Valve Speed**—Amount of change the manual increment / decrement will adjust the valve. This defines the amount of duty cycle change for PWM each time the manual increment or decrement is pressed.

## PWM Settings Tool









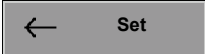

The PWM Settings Tool allows a user to easily set the zero flow offset, PWM standby, and max duty cycle of the valve on implement. It allows the user to manually increase and decrease flow. The tool will display the current duty cycle of the valve and the current pressure on the system.

 **NOTE!:** A digital pressure sensor or analog pressure gauge is

required to use this tool.

Enter the PWM Settings Tool.

1. Each press of  will increase the duty cycle of the valve, and each press of  will decrease the duty cycle of the valve.
2. Press  until the system registers pressure. The minimum amount of pressure from zero pressure is desired.
3. Press  and Zero Flow Offset Value should change to the current duty cycle shown for the valve.
4. Press  until the system achieves the pressure that is desired for the system to hold when all sections are off.
5. Press  and PWM Standby Value should change to the current duty cycle shown for the valve.

6. Press  until the system achieves the maximum pressure desired.
7. Press  and Max Duty Cycle Value should change to the current duty cycle shown for the valve.
8. Press  to save these settings or press  to discard these settings.

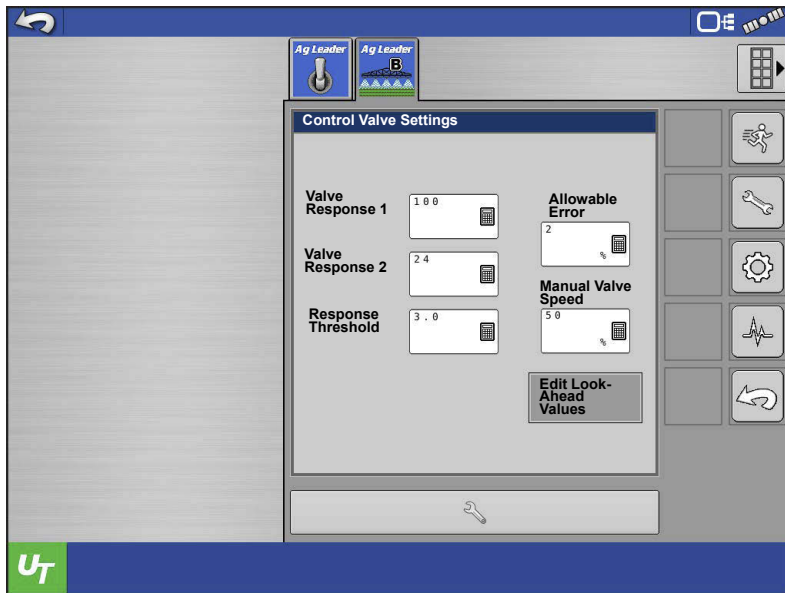

This Control Valve Settings screen will be provided for profiles setup with the control valve types listed below.

- Inline Servo
- Bypass Servo
- Pump Servo
- Ramsey
- Aim Command

 **NOTE!** If these settings show

up and you do not have one of the listed control valves, verify the correct profile is selected. If the correct profile is active, the profile needs reconfigured.

- **Valve Response 1**—The speed of the servo valve when product control error exceeds the Response Threshold setting. Valve Response 1 represents the fast speed of the servo valve.
- **Valve Response 2**—The speed of the servo valve when product control error is less than the Response Threshold setting. Valve Response 2 represents the slow speed of the servo valve.
- **Response Threshold**—Determines where the control channel switches between using Valve Response 1 and Valve Response 2 speed setting.
- **Allowable Error**—The percent of error that is allowed prior to the product control system making any flow rate changes.
- **Manual Valve Speed**—amount of change the manual increment / decrement will adjust the valve. Essentially this changes the amount of time the valve is driven for a servo valve.



## Edit Look-Ahead Settings

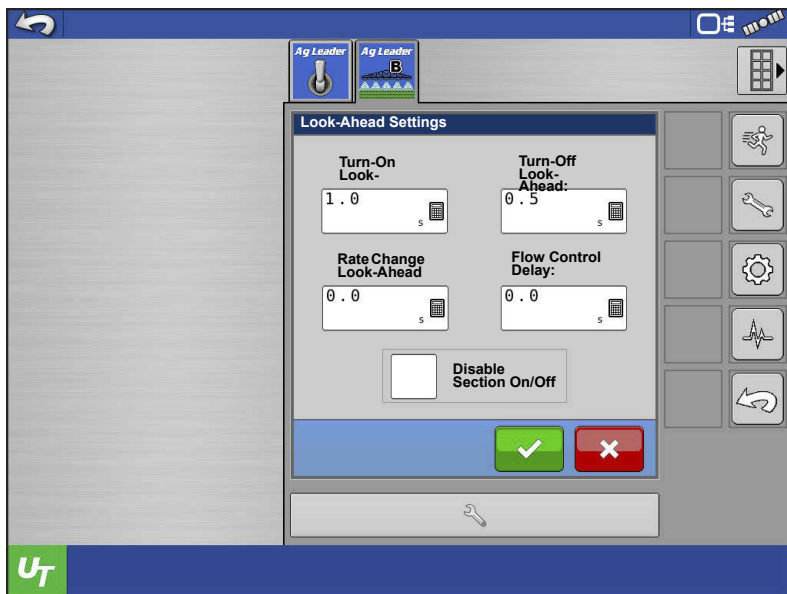

**•Turn – On Look-Ahead—**

Determines how far ahead the system looks to turn the swath sections back on. This setting compensates for any delay in the product control system when the sections are turned on.

**•Turn – Off Look-Ahead—**

Determines how far ahead the system looks to turn the swath sections off.

This setting compensates for delay in the product control system when the

boom sections are turned off.

- **Rate Change Look-Ahead**—Determines the amount of time the system looks ahead to the next target rate zone of a prescription.
- **Flow Control Delay**—Period of time from master switch on and the start of product application to the first flow control correction. This setting can be used to eliminate unwanted correction of flow control at the start of each pass. Typical setting values are zero for granular and 1 –2 seconds for liquid application control.
- **Disable Section On/Off Delays**—Disables the Turn-On and Turn-Off Look Aheads. Disable these when using a non-Ag Leader display that has its own look ahead settings.

Connected display will handle section delays. If this option is disabled, users must uncheck ECU Section Delays in ISOBUS settings.

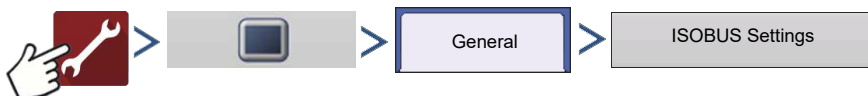

## Alarm Settings

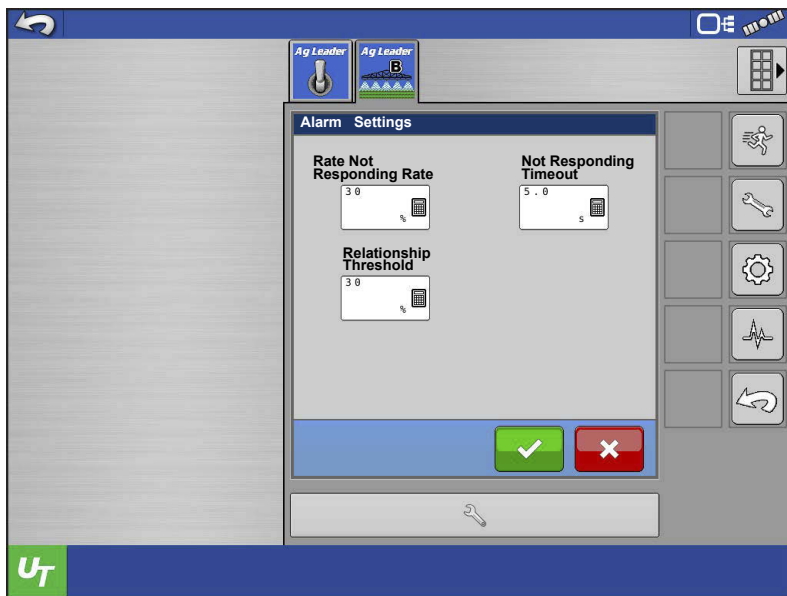

The Rate Not Responding alarm is a user defined alarm that alerts the operator when the actual rate is off of the target rate by a define amount, for a certain amount of time.

**Rate Not Responding Threshold—**  
The percentage of rate error that triggers the alarms.

**Rate Not Responding Timeout—**  
The amount of time that the error occurs before the alarm triggers.

**Relationship Threshold—**The percentage of error allowed between the flow rates.

Flow rate from the flow meter, and the flow rate calculated from the main system pressure, must be within the defined threshold. The alarm associated with this setting is

**“Pressure/Flow out of Relationship.”**

## System Settings

### Switch Systems

Switching systems can be useful with multi-purpose machines. It gives you the ability to switch between one of the below system types.

- Sprayer
- Anhydrous Ammonia
- Liquid Fertilizer
- Liquid Manure



**ATTENTION!:** Upon the first initial start up of the module, the user will be prompted with the message "System has not been configured. Press accept to begin setup." The user can then pick from one of the available system types listed above.



**ATTENTION!:** With all four system types, if only 1 section is the desired number of application sections, a swath module is not required. In order for a system to be utilized in this manner, the ISOBUS Liquid Product Module will need to be updated to version 1.9, or greater.

The system has the ability to set up two systems,



System A and



System B. The active system can be identified by the A or B shown on the object pool tab on the UT screen.

Once a system type is selected, each profile created under that system will be created as that system type.

An example of using multiple systems would be a self-propelled sprayer that uses a spray boom, and can also use an injection toolbar for side dressing. In this case the user would set up a Sprayer system. The user could also have different profiles under that system for different swath widths and number of section, if they want to fold in boom extensions.

The user would set up system B as a Liquid Fertilizer system. This could also have profiles with different swath widths and number of sections. Then when the machine switches between

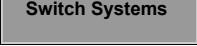

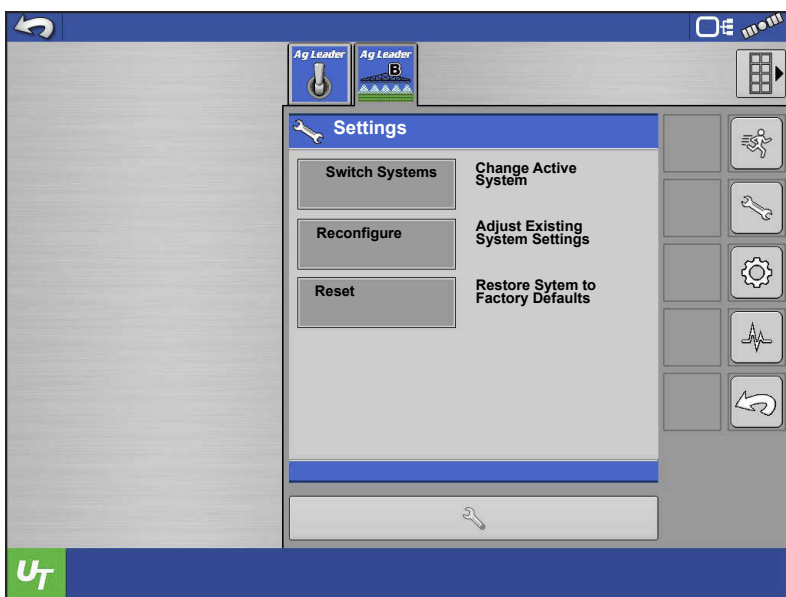
spraying and side dressing the user simply needs to press  and select which profile to activate.



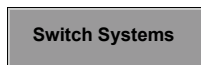

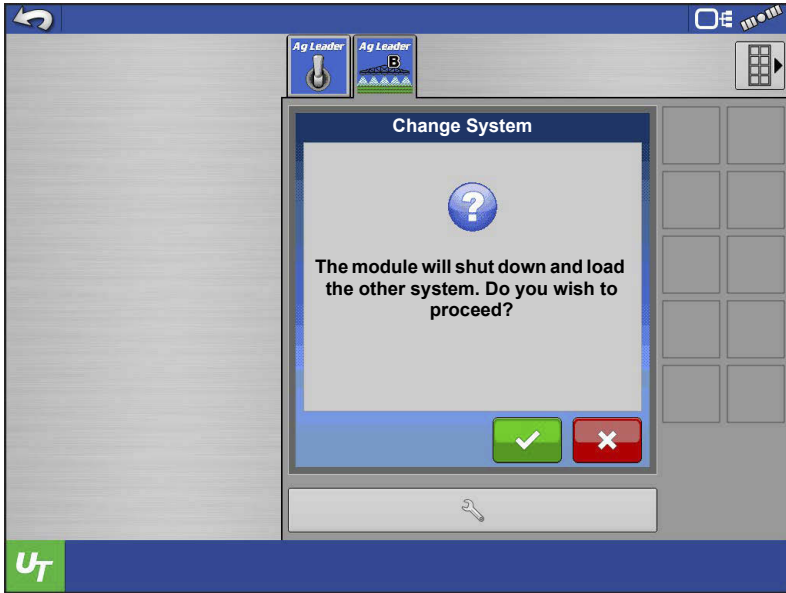
To switch systems, press



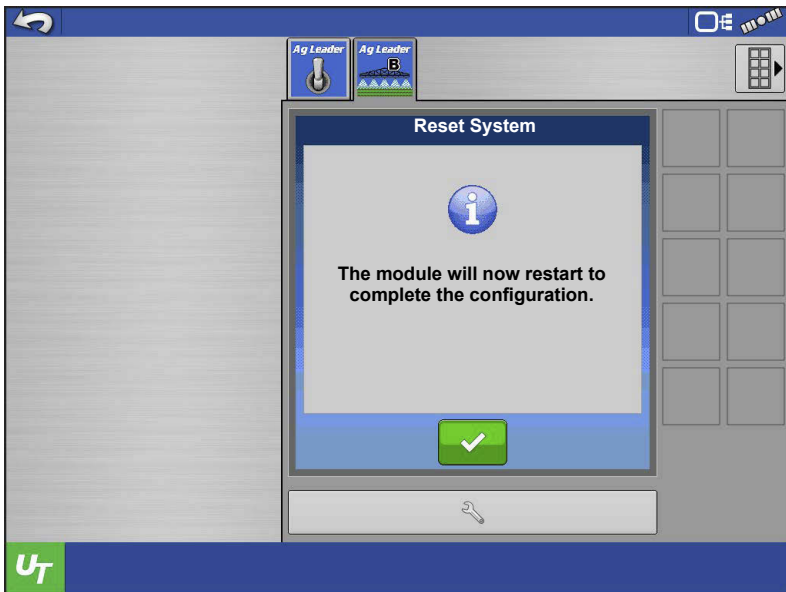

The module must reboot to switch systems. To cancel switching systems, press . Otherwise press  to continue.



Press  to finish switching systems.

## Reconfigure

Reconfigure allows the user to change edit configuration information regarding sections. This is handy if the user didn't know the number of sections when creating the configuration, if extra sections or end row nozzles are added to a machine, or disabling a section.

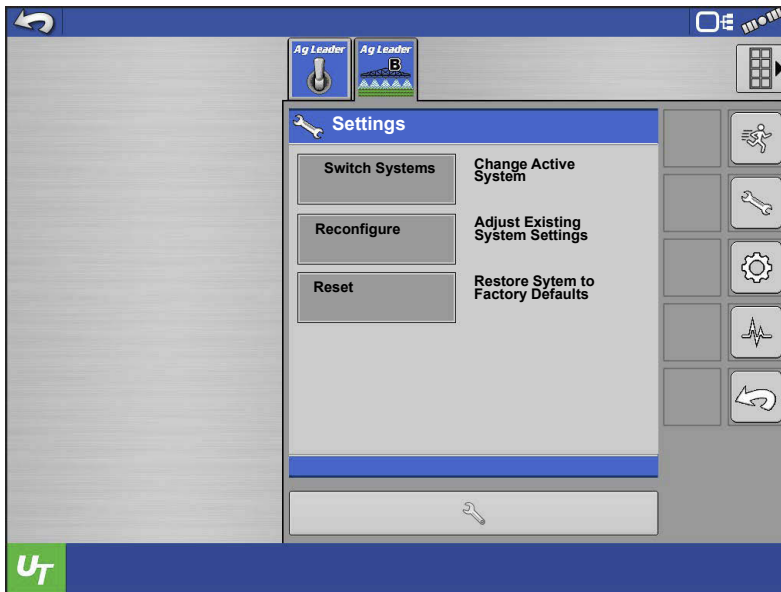

1. To edit the section information of the active profile, press  .

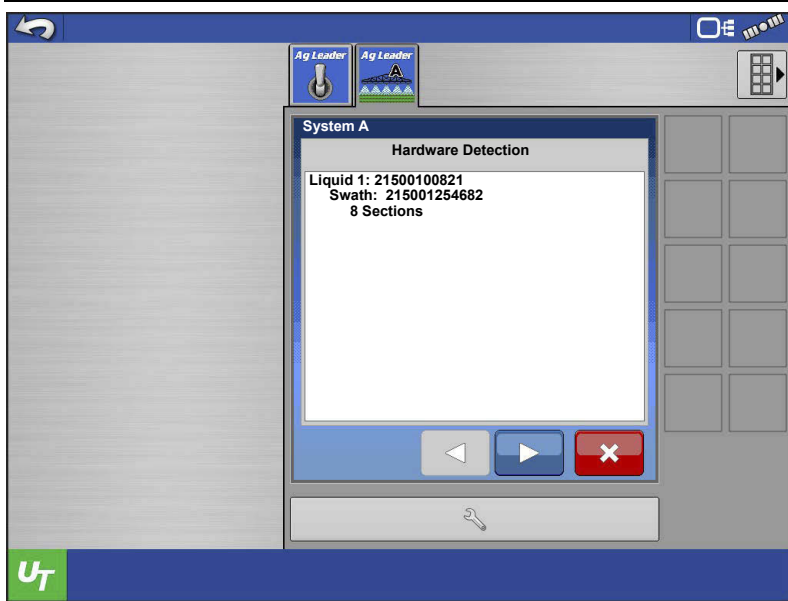

2. The module will do a hardware detection, press .

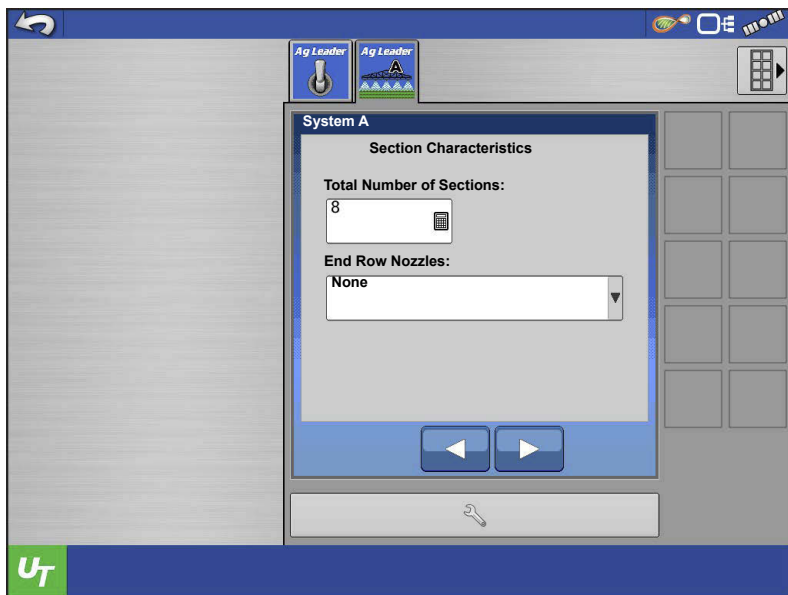

3. Edit the number of sections or end row nozzles if necessary, press



 **ATTENTION!:** Starting in version 1.9 of the ISOBUS Liquid Product Module support of up to 36 boom sections was implemented. The operating display must also support the desired amount of boom sections.

Ag Leader has recommended validation steps that need to be performed on a sprayer to determine if the liquid control system can support more than 24 sections. These validation steps will determine if the liquid control system can accurately control flow on small width boom sections at varying speeds and AutoSwath scenarios. If a boom section has too small of a width, the liquid control system may not have the ability to lock onto rate. This will be more prevalent with high capacity sprayers.

Ag Leader recommends these steps be taken for all sprayer control types, other than calibrated reflow. Through testing, calibrated reflow control systems can accurately control flow up to 36 boom/nozzle sections. Validation steps can be found on the Ag Leader Knowledgebase.

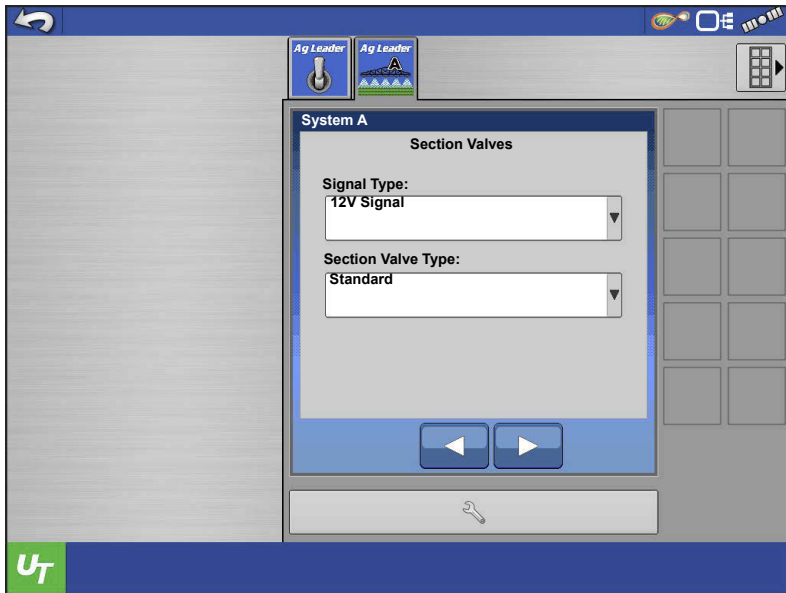

4. Edit the signal type or section valve type if necessary, press .

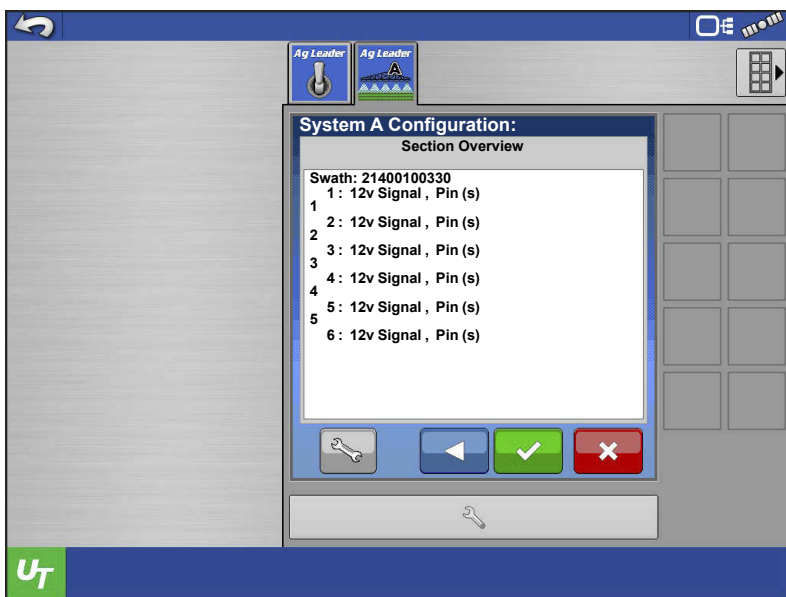

5. Verify the section overview is correct.

•If it is correct, press  to finish and save.

•If it is not correct, press  to edit.

•Press  to cancel.

## Reset

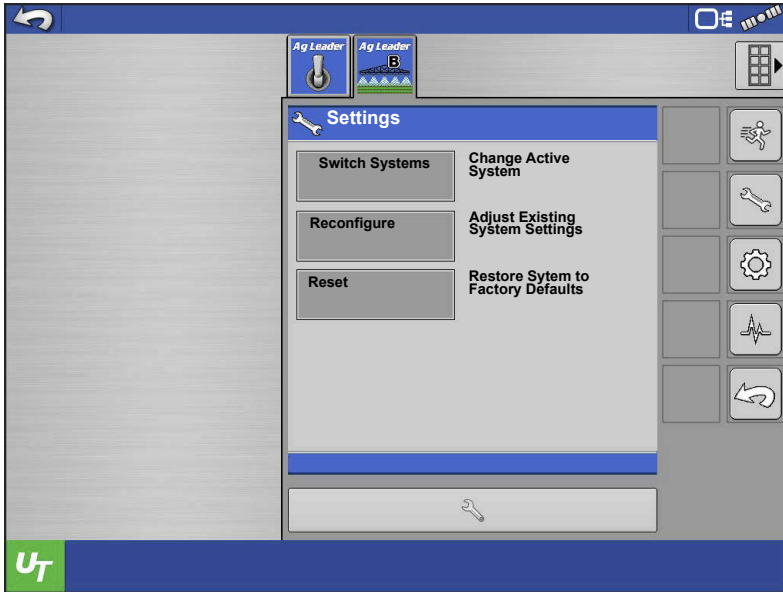

Pressing Reset will delete all profiles and data stored in the module for active system. For example, resetting while system A is active will delete all profiles and data stored in the module for system A. Profiles and data for System B will still be intact.

1. To reset the active system press

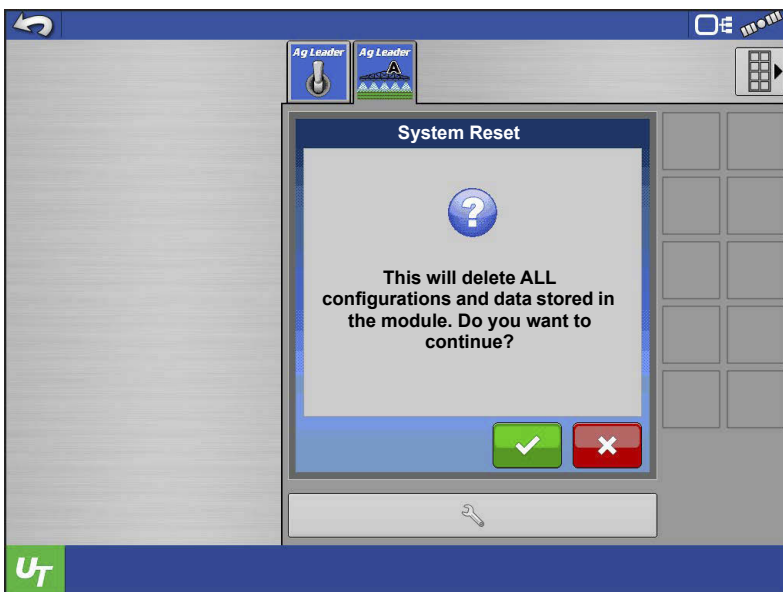
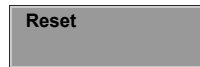

2. A warning will appear on the screen.

• To finish the reset, press .

• To cancel the reset, press .

The module will reboot and require a profile to be setup.



## UT Settings—Switch Setup

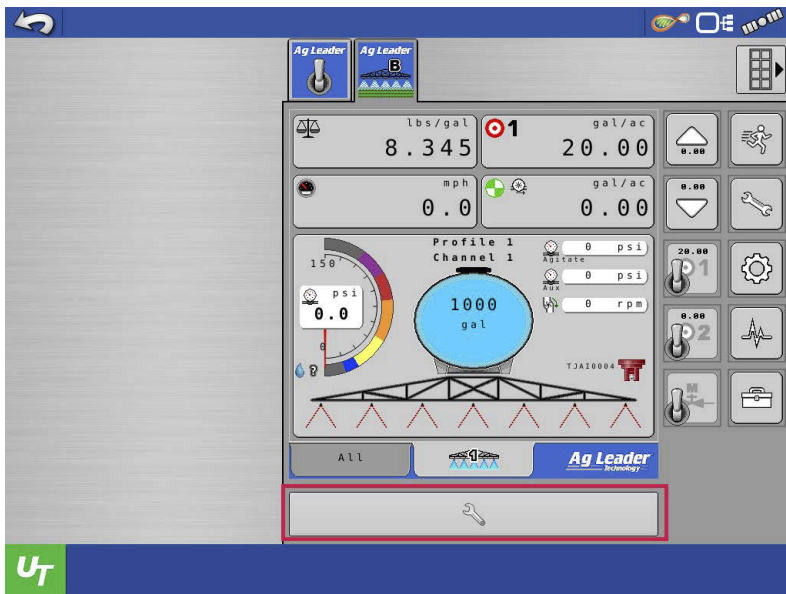

To configure auxiliary switches for control module functions (i.e. master switch, boom sections, rate selection), press the Wrench to open the Universal Terminal Settings screen. Then select Auxiliary Assignment.



## Calibration

### Flow Sensor Calibration

The system offers four types of calibration methods. The methods available will depend on which profile type is currently active system. The table below illustrates which methods are available for each system.

---

	Manual Calibration	Nozzle Catch Test	Field Dispense Volume	Static Dispense Volume
Sprayer	X	X	X	X
Anhydrous Ammonia Toolbar	X		X	
Liquid Fertilizer	X	X	X	X
Liquid Manure	X		X	

One of the methods will need to be performed in order to operate the system. Manual calibration is recommended to be performed before any others. Below provides an explanation of each method.

**Manual Calibration**—Entering the flow sensor calibration number. This value can typically be found on the flow sensor.

**Nozzle Catch Test**—Catching and measuring the amount of produce dispensed from a single nozzle for the duration of one minute. The user will enter actual amount dispensed and the flow sensor calibration number will be adjusted.

**Field Dispense Volume**—A load will be applied and recorded in the field, typically an entire tank or bin. The user will enter the actual amount of product applied (obtained from a scale ticket or weight system) and the flow sensor calibration number will be adjusted.

**Static Dispense Volume**—The user will apply product in a stationary position, catch and measure the amount of product, and input the amount of product that was dispensed. The flow sensor calibration will then be adjusted.

## Manual Calibration

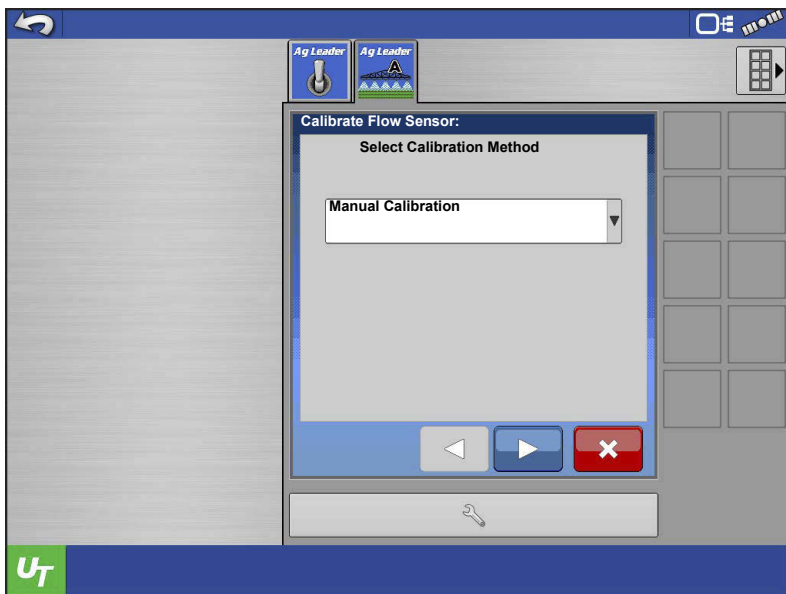

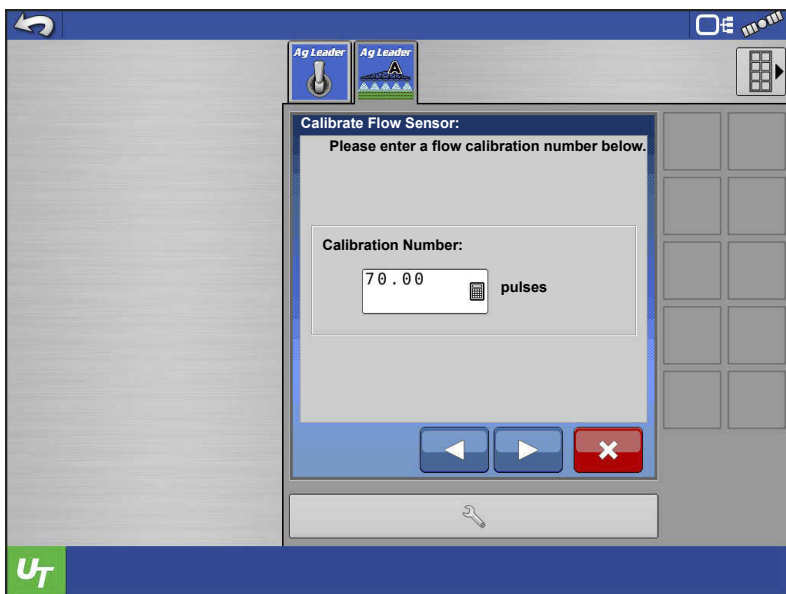

1. Select Manual Calibration from the combo box and press .

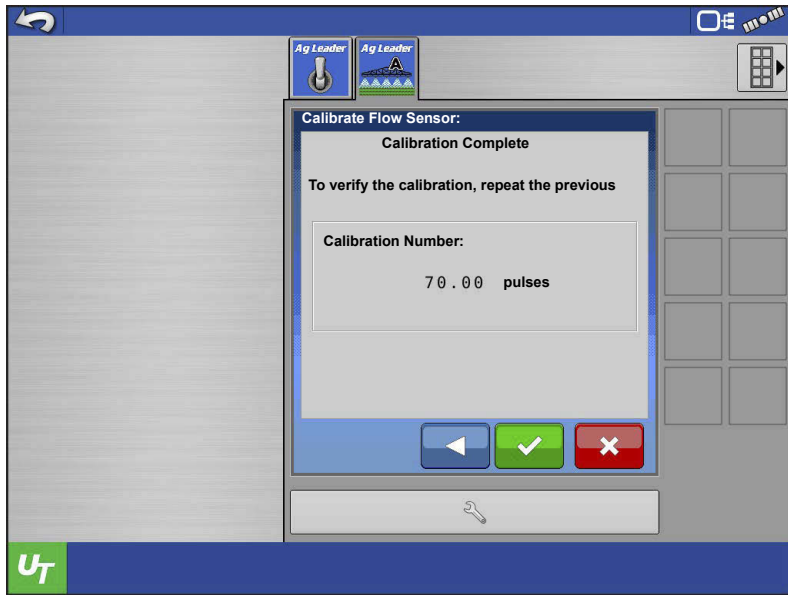

2. Enter the flow sensor calibration number.

 **NOTE!:** The system measures impulses/gallon (liter). Some sensors measure in 10 or 2 pulses/gallon (liter). These calibration numbers will need to be altered. Example: A raven flow sensor reads 10 pulses/gallon. A calibration number of 720 would be entered as 72 into the system.



3. The calibration is complete and new calibration number sound be displayed. Press  to finish.

## Field Dispense Volume

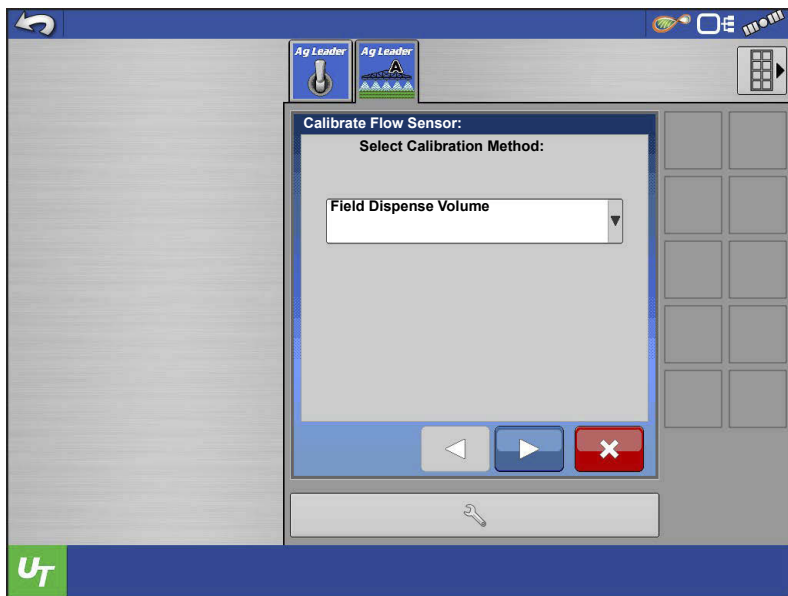

For this calibration method to work, product needs to be applied in the field before calibrating, preferably an entire tank or bin.

1. Select Field Dispense Volume form the combo box and press .

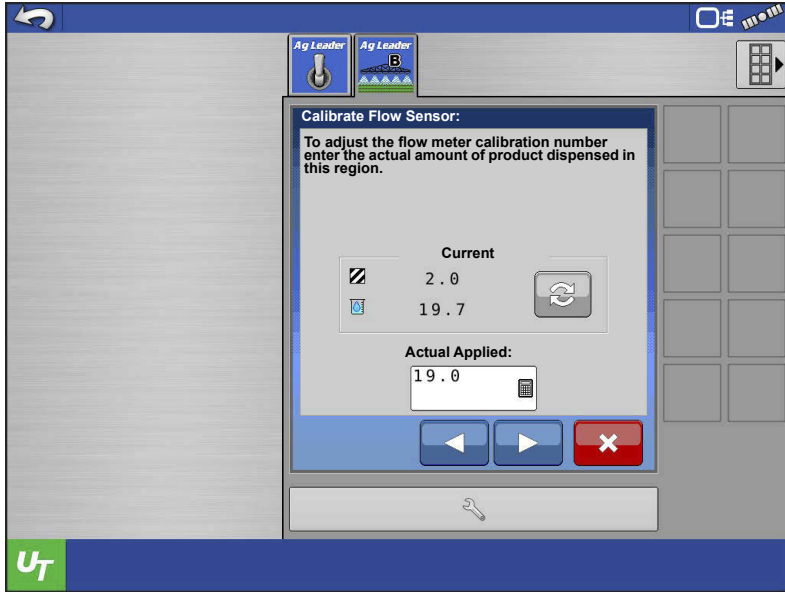

2.The recorded acres and total product will be displayed.

3.Enter the actual amount of product applied and press .

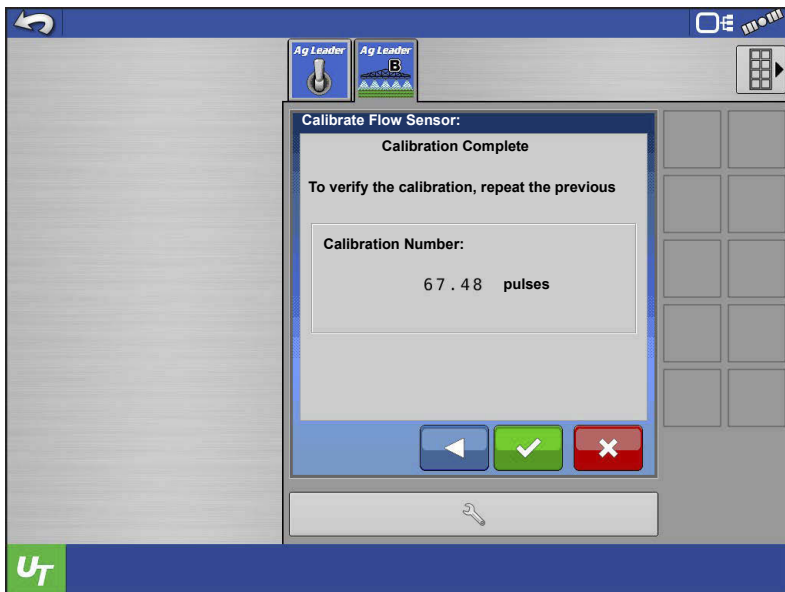

4.The calibration is complete and new calibration number sound be displayed. Press  to finish.

# Nozzle Catch Test

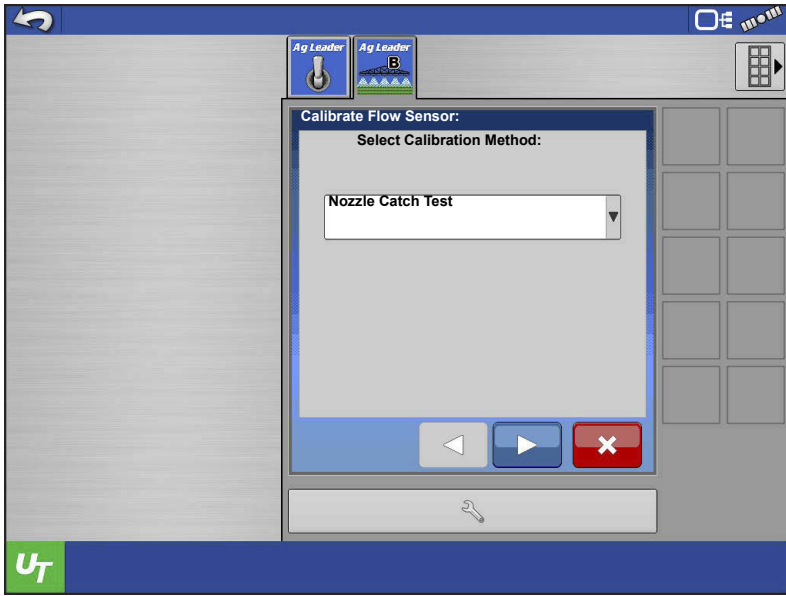

1. Select Nozzle Catch test from the combo box and press .

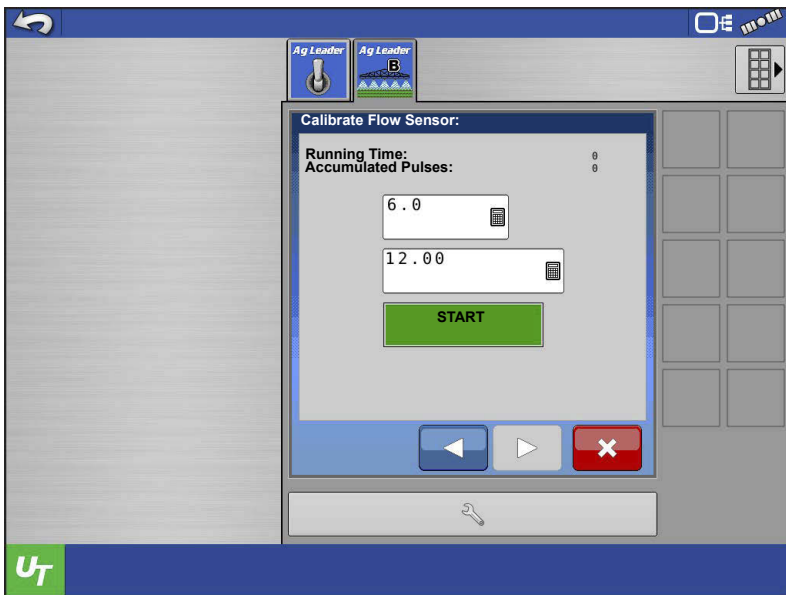

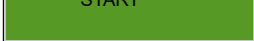

2. Enter a simulated speed and target rate.

3. Press  when product is ready to be dispensed and someone is in position to catch the product from a single nozzle.

 **NOTE!:** It is recommended to enter a speed and rate similar to what the system will be operating at in the

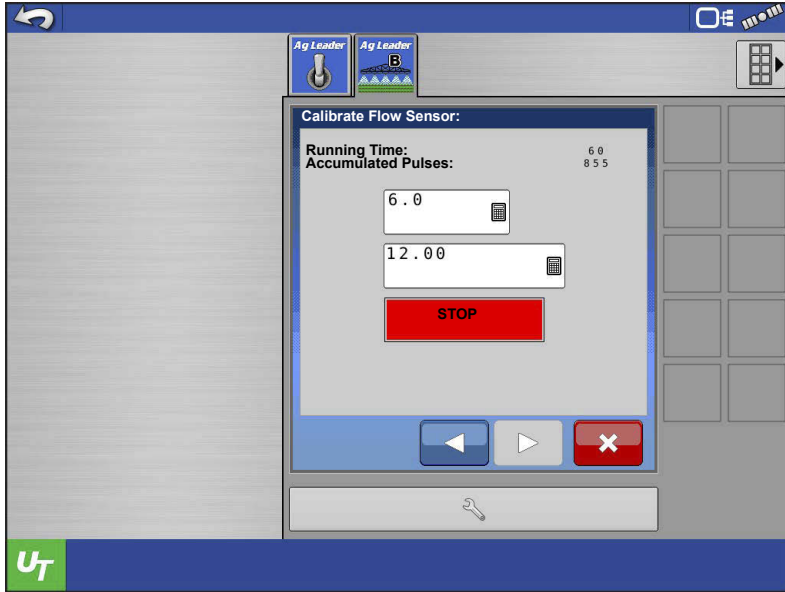
field.



4. Press  when the Running Time has reached 60 seconds. A box to enter the Observed Flow will appear.

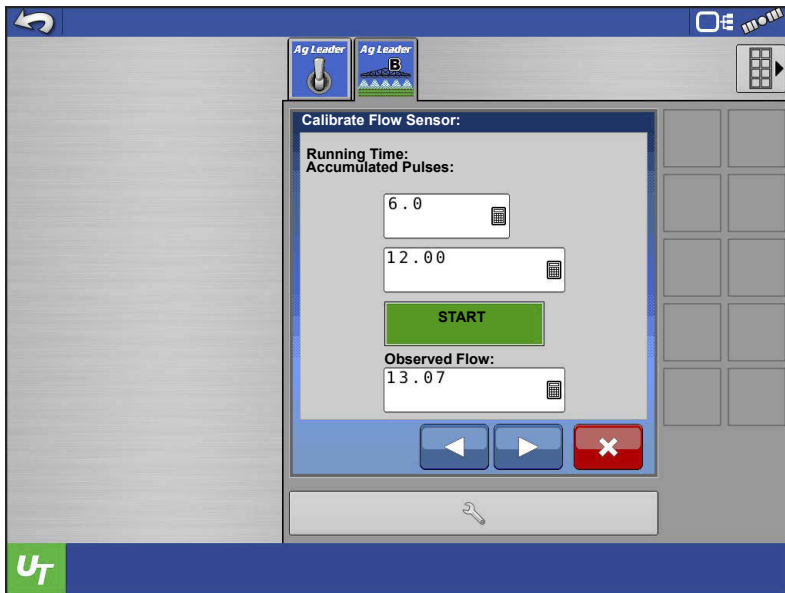

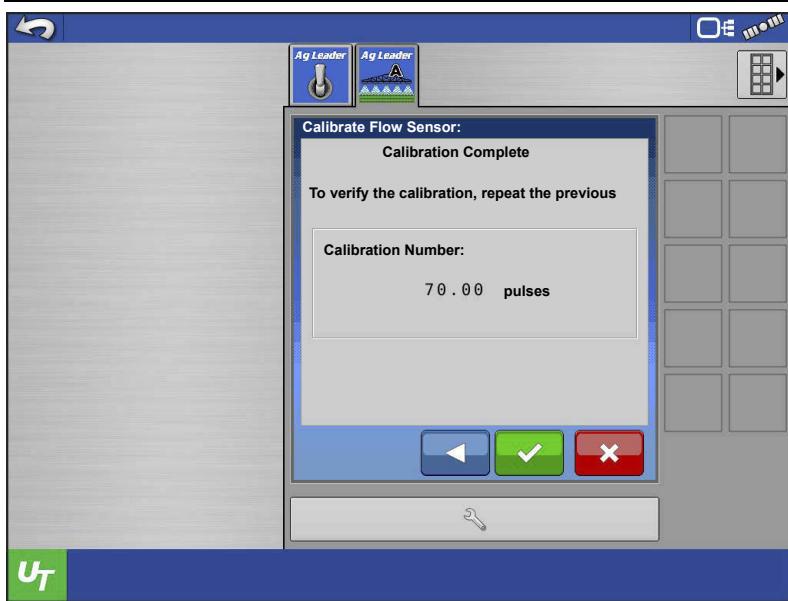

5. Enter the amount of product that was collected in units of gal/min. Press .

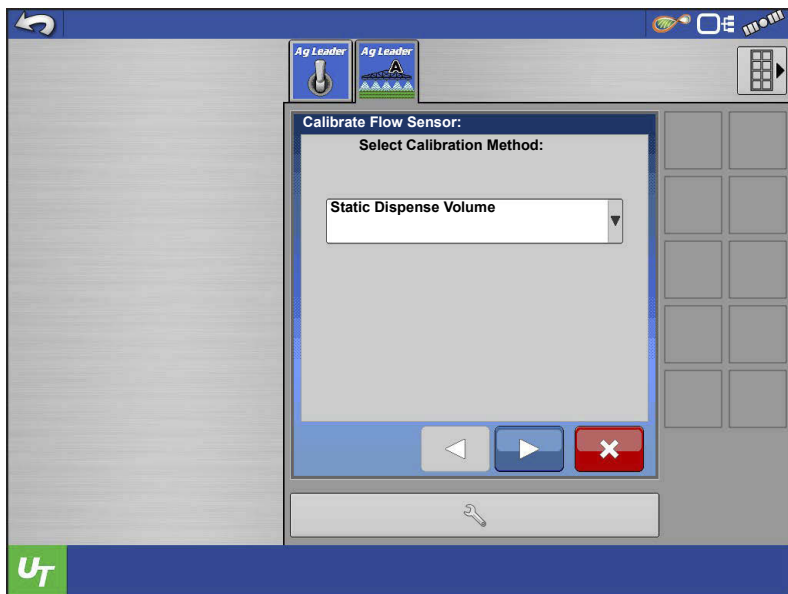

6. The calibration is complete and new calibration number should be displayed. Press  to finish.

## Static Dispense Volume



1. Select Static Dispense Volume from the combo box and press .



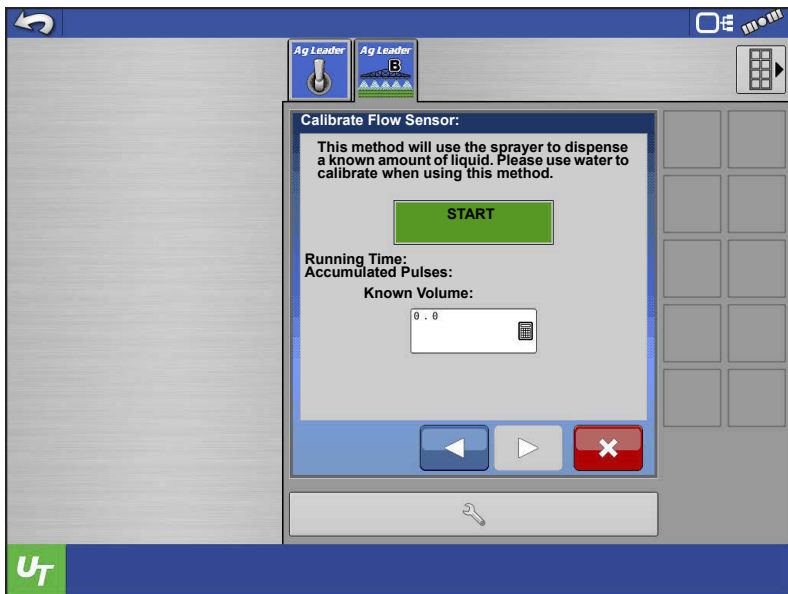

2. When the machine is ready to dispense product, press

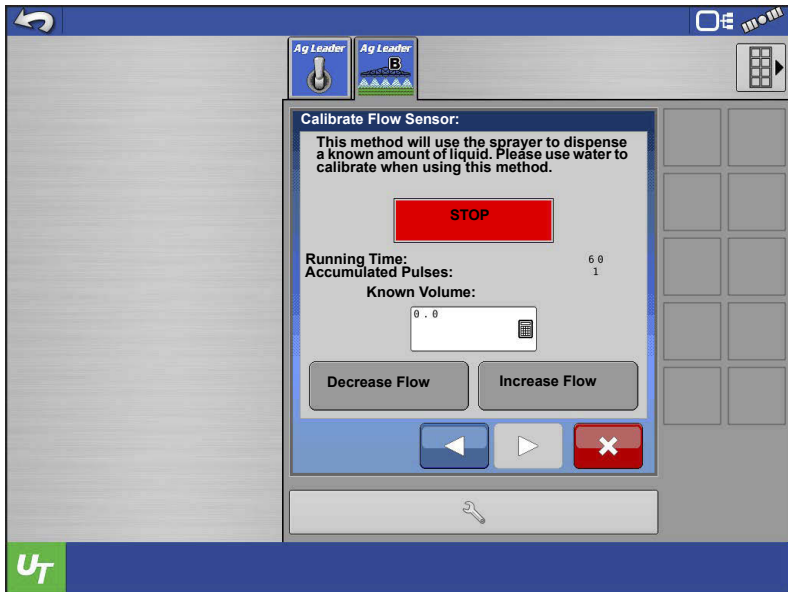

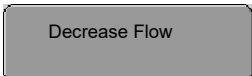
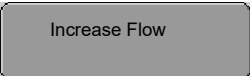
3.  and  should appear and all section valves should open.

CAUTION: Make sure all personal are at a safe distance before dispensing product.

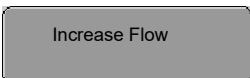
4. Press  until product begins to dispense and a

desired pressure is achieved.

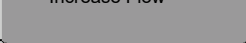
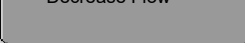

**NOTE!:** Pressing and holding  or  will not continue to open or close the valve. The user must press the button each time they want the valve to open or close.

5. Allow the system to dispense a desired amount of product.

6. Press  once the desired amount has been dispensed.

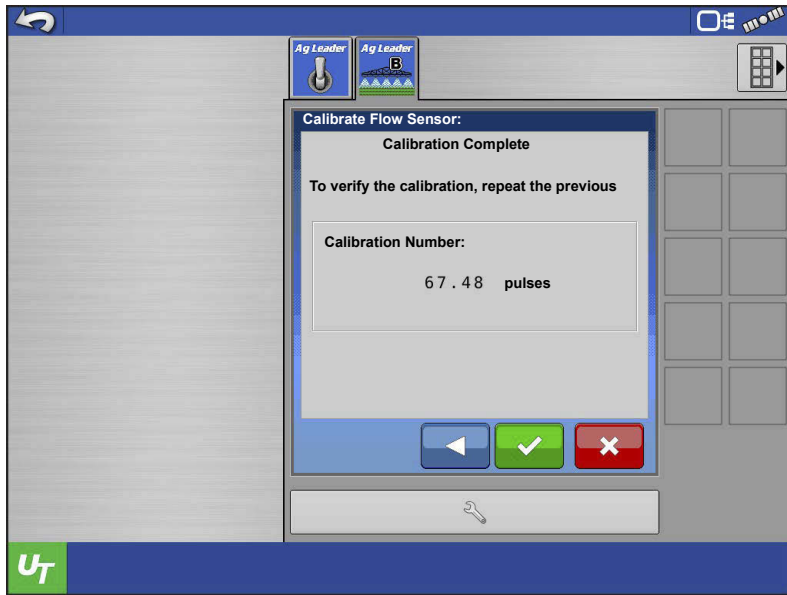

7. Enter the amount of product that was actually dispensed into the

Known Volume box and press .

8. The calibration is complete and new calibration number should be displayed.

9. Press  to finish.

## Pressure Sensor Calibration

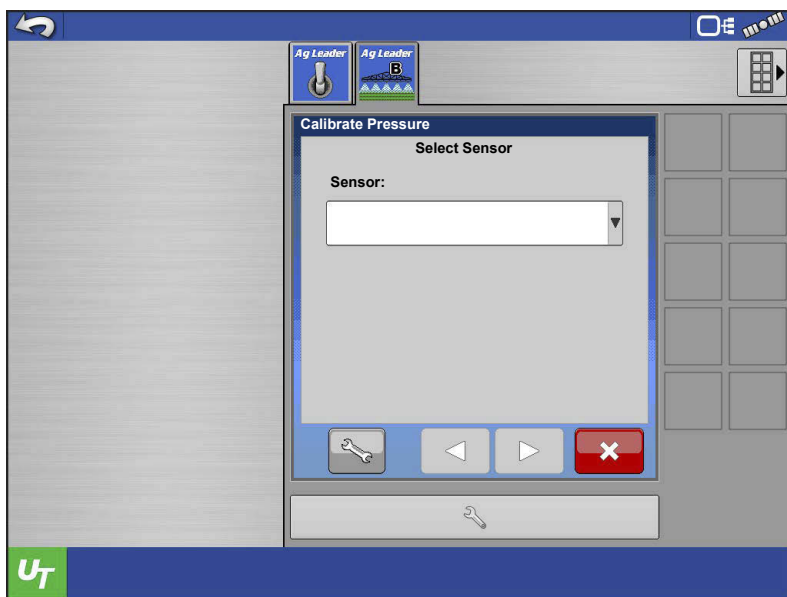

1. Select which pressure sensor to calibrate from the combo box.

If none appear in the combo box,

press  in the lower left corner to activate pressure sensors.

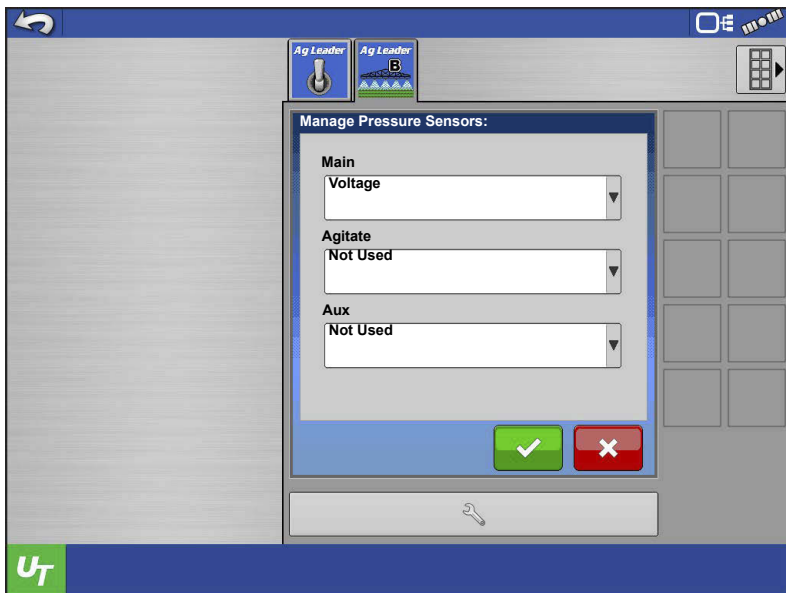

2. Define whether the sensor is a voltage or current loop sensor. Ag Leader sensors should be selected as Voltage.

3. Once all sensors are defined press

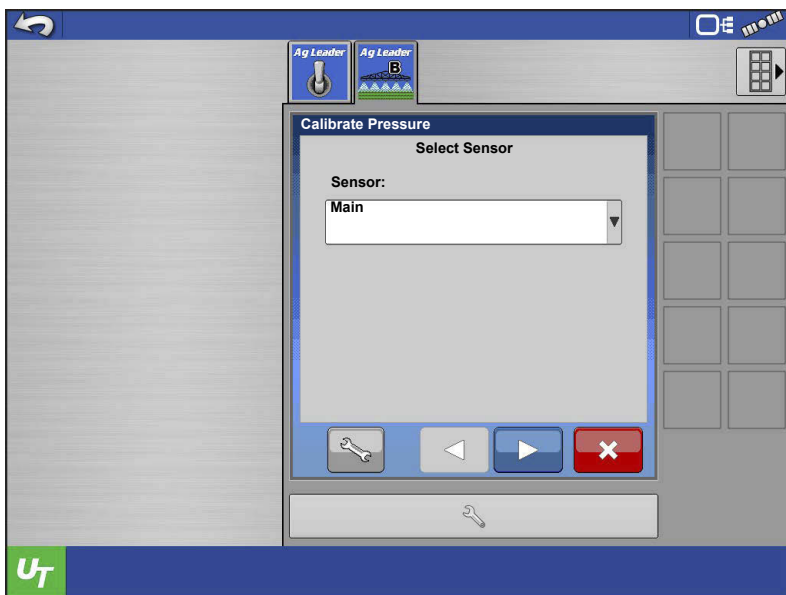

4. Select a sensor to calibrate and press .

5. Each sensor can be calibrated using a Single Set Point or Multiple Set Points.

**Single Set Point Method**—Will record the mV the sensor is seeing at a single pressure reading. (Recommended to record mV value when the sensor is seeing 0 psi).

**Multiple Set Point Method**—Will record the mV the sensor is seeing at zero pressure and at a non-zero pressure. The system will require an analog gauge to be present in the system for this method.

## Single Set Point Calibration

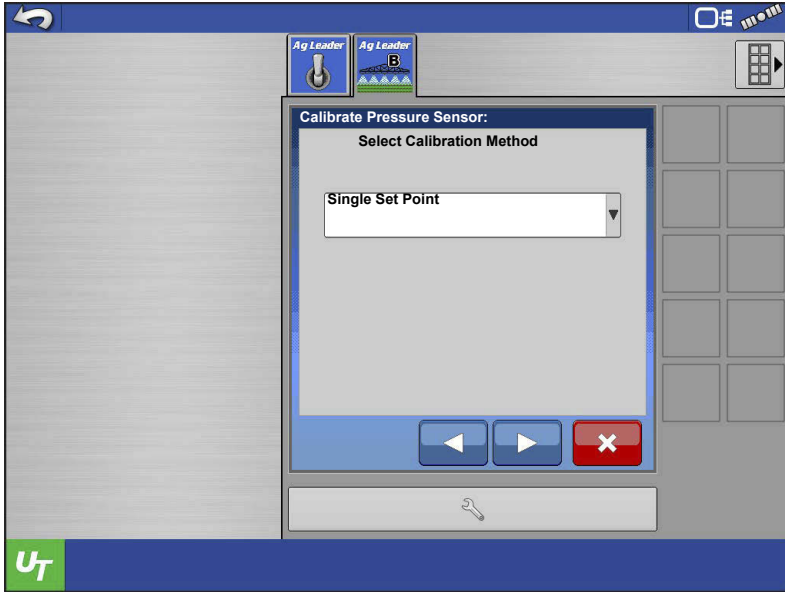

1. Select Single Set Point Calibration from the combo box and press .

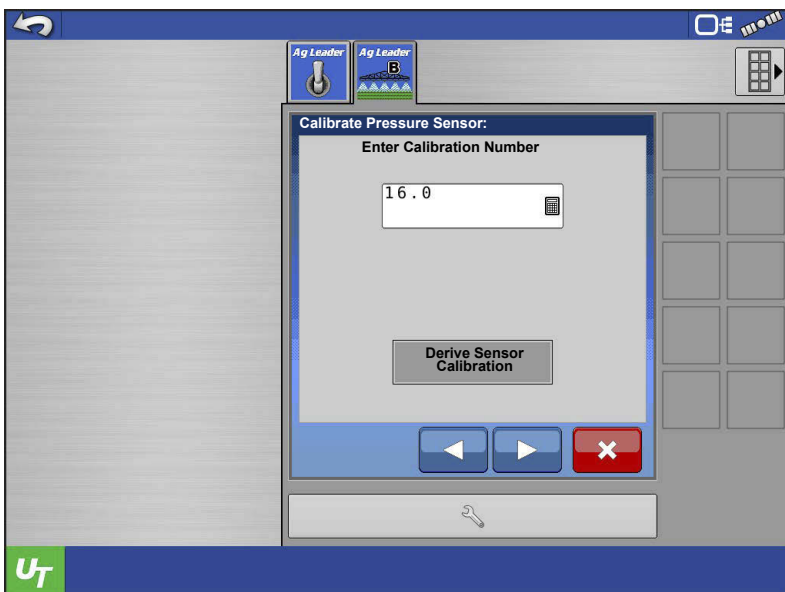

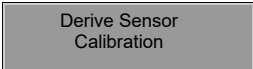
2. Enter the mV/psi calibration value of the sensor. A sensor provided by Ag Leader is 16 mV/psi. If the calibration number of the sensor is unknown, press .

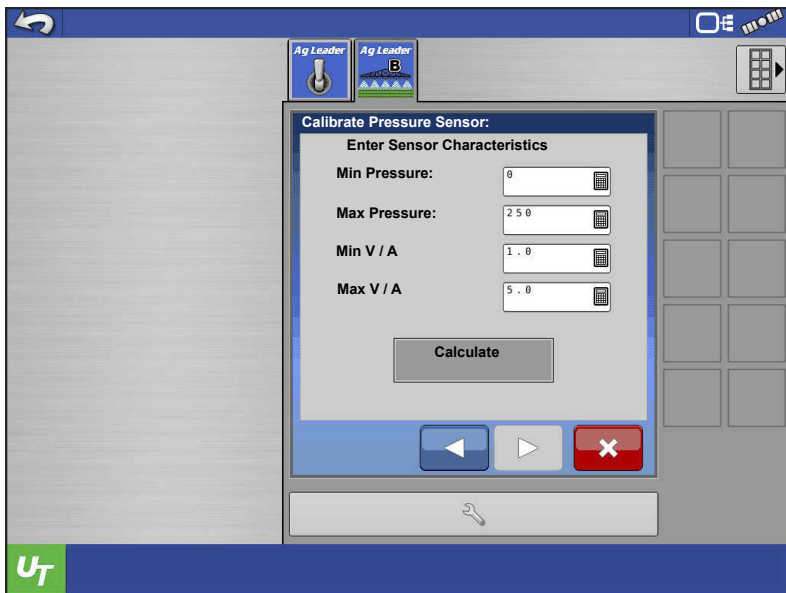

3. Enter the Min and Max Pressure, as well as the Min and Max voltage or milliamp values of the sensor. (Ag Leader's sensor is a Voltage Loop style sensor.) Sometimes these can be found on the sensor itself, otherwise contact the sensor's manufacturer.

4. Once the values are entered, press

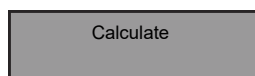

5. The derived Calibration Number should be present in the box. Press .

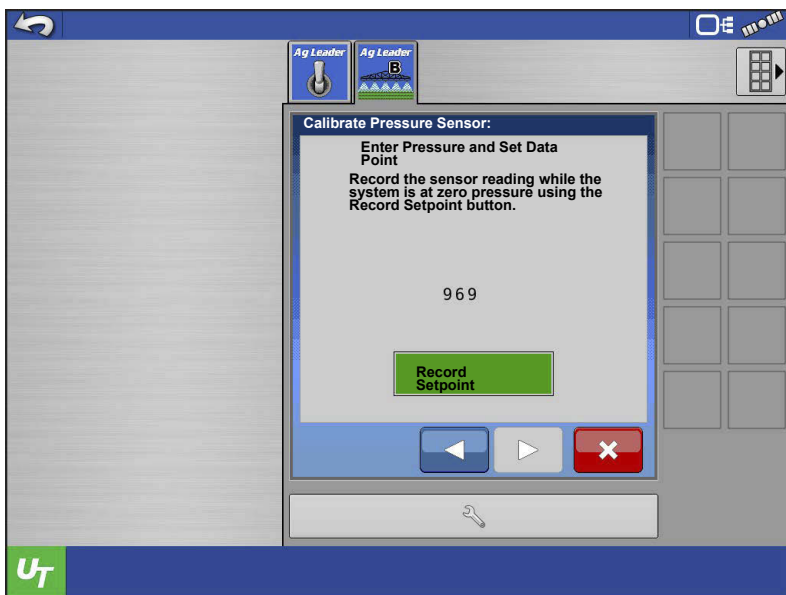



6. Press  to record the current sensor reading once the system is at zero pressure.

7. Press .



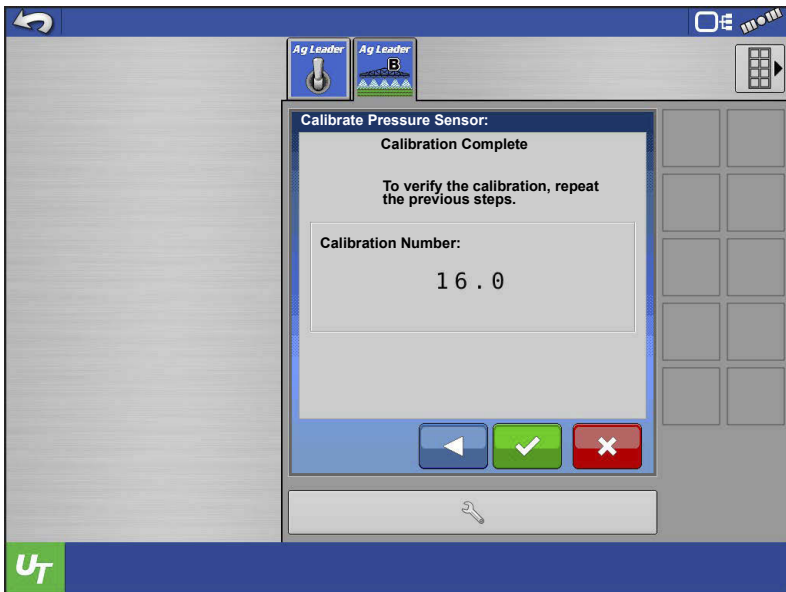

8. Press  to redo the calibration.

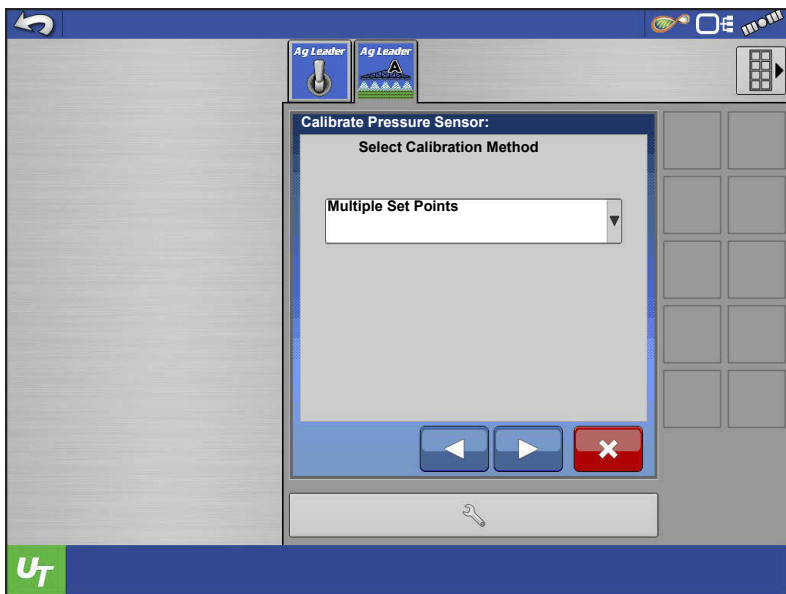

9. The calibration is complete and new calibration number should be displayed. Press  to finish.

## Multiple Set Point Calibration



1. Select Multiple Set Point Calibration from the combo box and press .

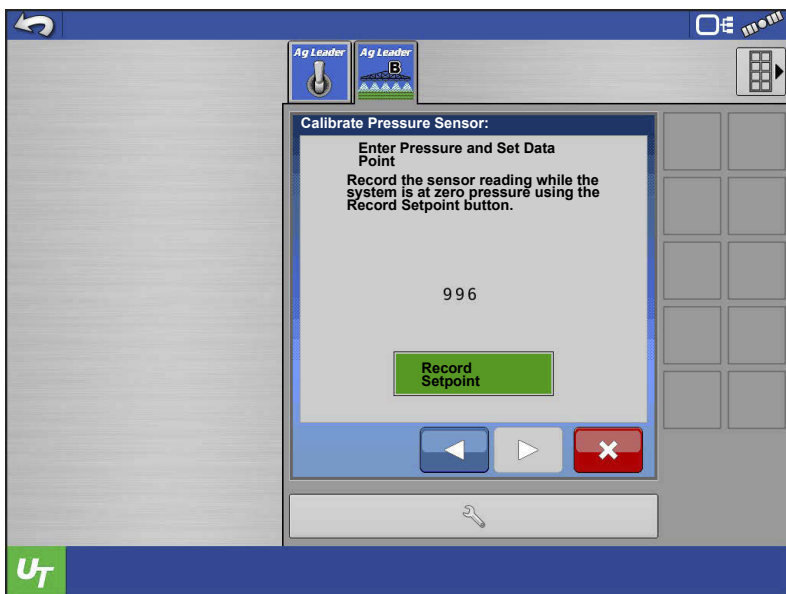





2. Press  to record the current sensor reading once the system is at zero pressure.

3. Press .

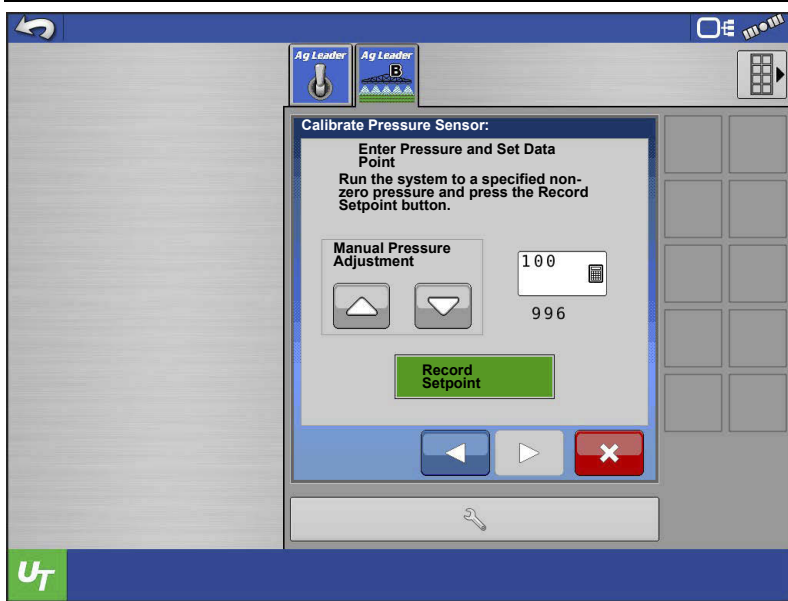
 **NOTE!:** Press

 to redo the calibration.



4. Use  and  to apply pressure to the system. Enter the pressure that is displayed on the analog gauge into the psi box and press .

5. Press .

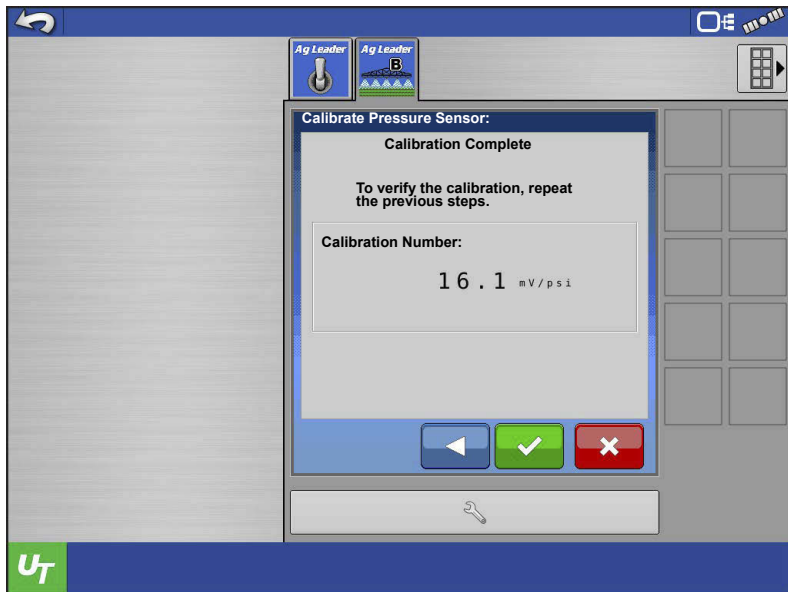



6. The calibration is complete and new calibration number should be displayed.

7. Press the  to finish.

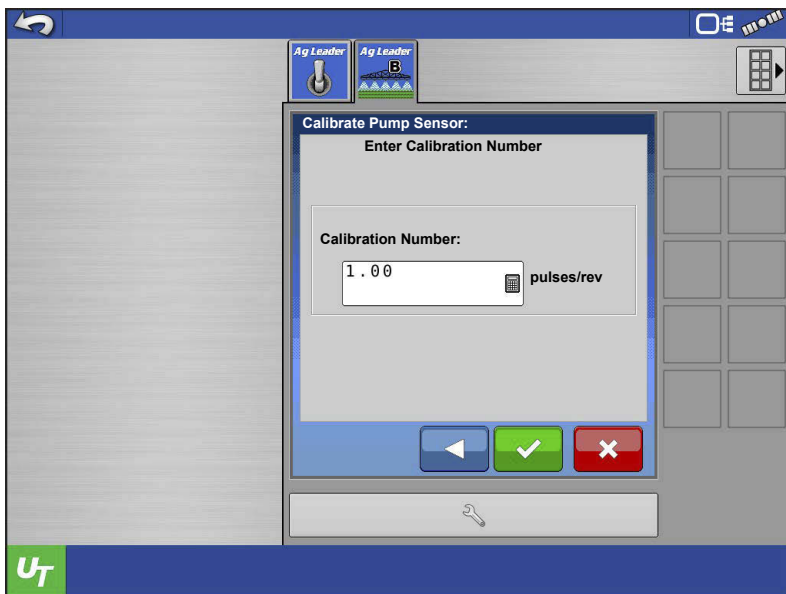

## Pump Speed Sensor Calibration



1. Enter the pulse/rev calibration value of the sensor.
2. The calibration is complete.
3. Press .

## Speed Sensor Calibration

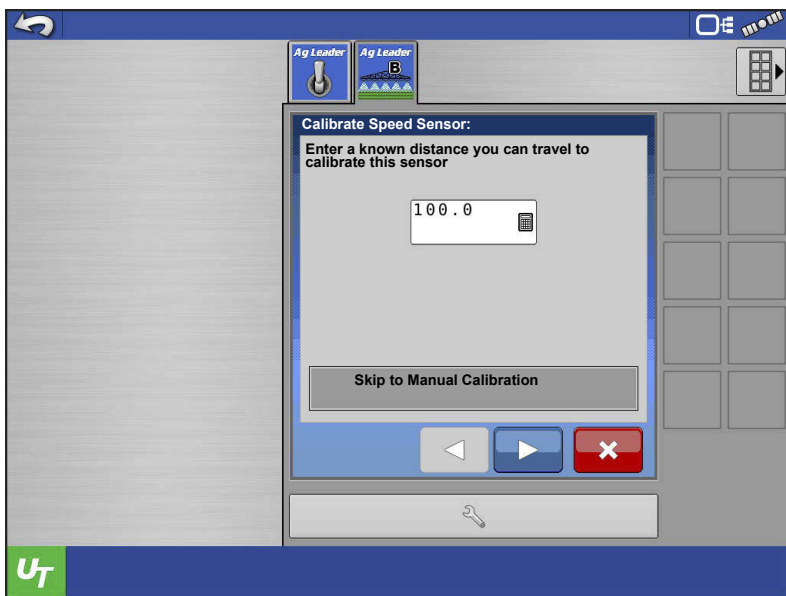

1. Enter the distance that will be traveled during the speed calibration.

If the pulses/100ft calibration value of the sensor is already known, press

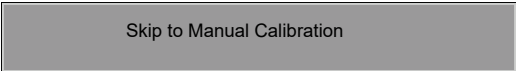

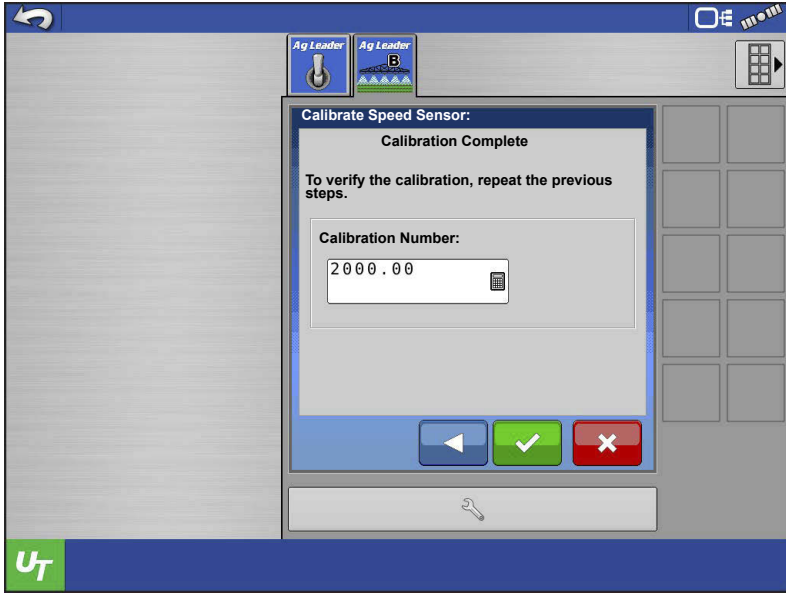

2. Enter the pulses/100ft calibration value of the sensor and press .

3. Press .

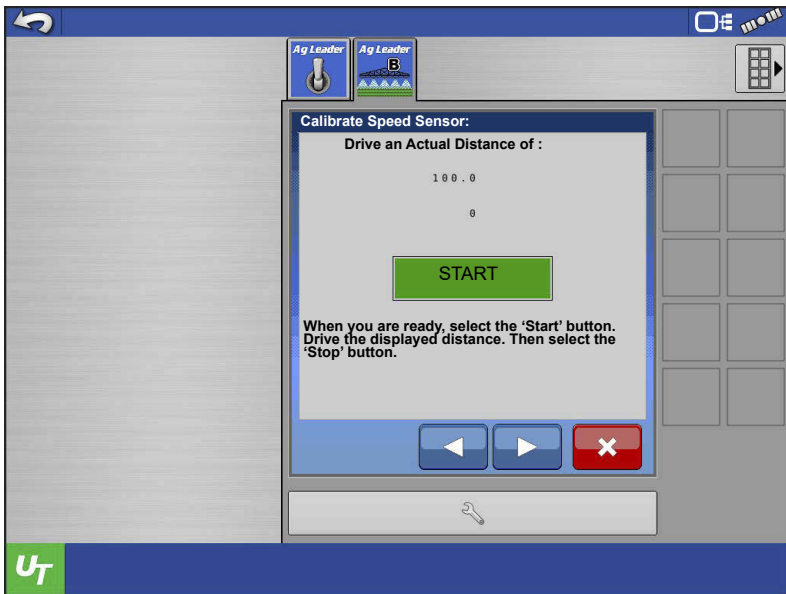

4. Once the vehicle is in position to drive the marked out distance, press  and begin driving the vehicle.

5. Press  once the vehicle has reached the end of the marked out distance.

6. Press .



7. The calibration is complete and new

calibration number sound be displayed.

8. Press  to finish.

## Temperature Calibration

A temperature sensor can be used on an Anhydrous Ammonia system type. The system can use a Voltage or Current Loop style sensor. The calibration routine will use a Single-Point calibration method.

1. Define whether the sensor is Voltage or Current Loop sensor.
2. Enter the mV/F calibration value of the sensor. If the calibration number of the sensor is unknown, press the Derive Sensor Calibration button.
3. Enter the Min and Max Temperature, as well as the Min and Max voltage or milliamp values of the sensor. (Ag Leader's sensor is a Current Loop style sensor.) Sometimes these can be found on the sensor itself, otherwise contact the sensor's manufacturer.
4. Once the values are entered, press the Calculate button.
5. The derived Calibration Number should be present in the box.
6. Press .
7. Enter the current temperature in degrees F, then press Record Set Point. Press .



**NOTE!:** Press the Reset button to redo the calibration.

8. The calibration is complete and new calibration number should be displayed.
9. Press  to finish.



## Diagnostics

## Module Diagnostics

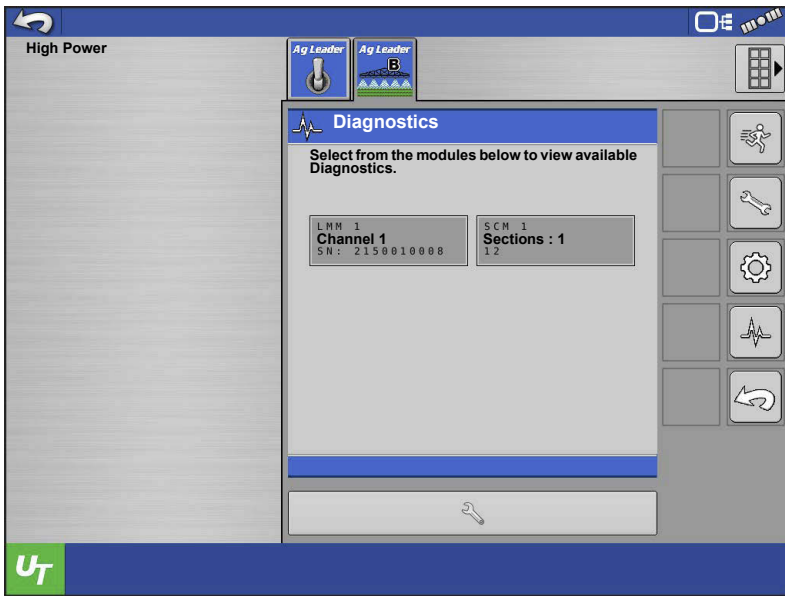

The modules on the ISOBUS will be displayed here. The user will select the module they wish to view diagnostics of. There should be an ISO Liquid Control module and may be one ISO Swath module present. Each ISO Liquid Control module will display a channel and serial number. Each ISO Swath module will display the sections it controls and a serial number.

## ISO Liquid Control Module Diagnostics (Status)

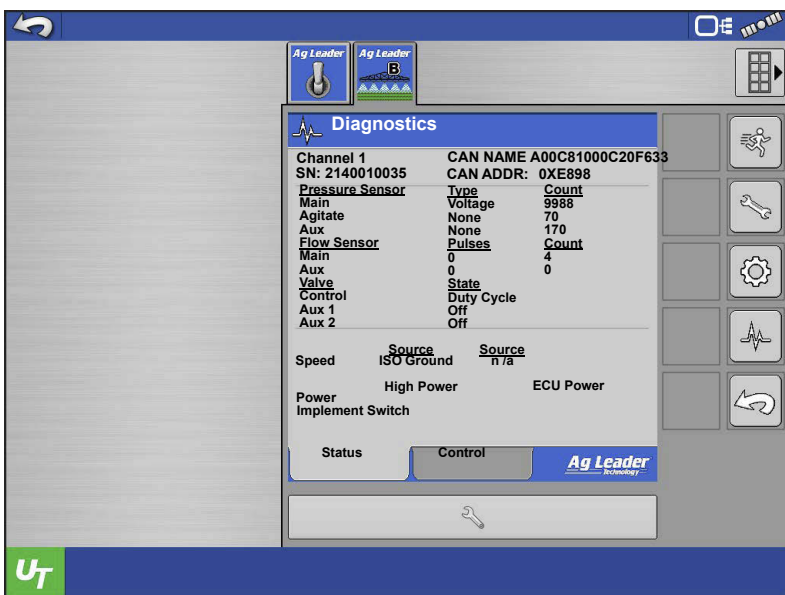

**Pressure Sensors**—The ISO Liquid Control Module Diagnostics shows a lot of useful information. It will show the pressure sensor defined type and number or counts the module sees from the sensor. If there was no pressure present, or the sensor was disconnected the count would show 0. The sensor type will show Current, Voltage, or None depending on what the user selected. If no sensors have

been defined yet it will show none.

**Flow Sensor**—The flow sensor will show the current number of pulses they sensor is sending and the total count of pulses.

**Valve**—Valve will show the current state of the control valve as well as the auxiliary valves. The control valve will show Increasing, Decreasing, or Idle depending on its state. The auxiliary valves will show on or off.

**Speed**—Speed will display the sources defined for the ISO Switchbox as well as the module. It will also display the current MPH.

**Power**—Power will display the current High Current power coming into the module as well as the ECU power.

**Implement Switch**—Implement switch will indicate if there is an implement switch module on the bus. If there is it will read Present, if not it will read Absent.

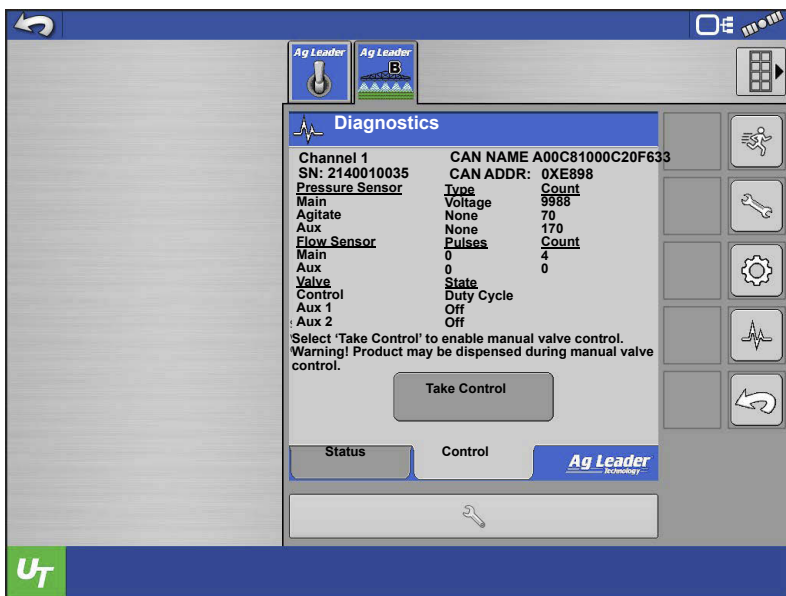

## ISO Liquid Control Module Diagnostics (Control)

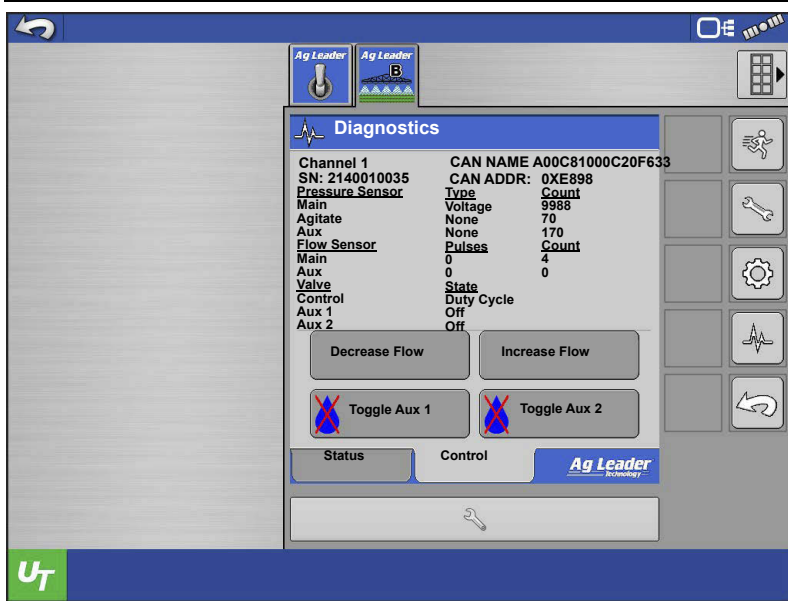

The Control tab will let the user take manual control of the control valve and auxiliary valve to diagnose any problems.

1. Press **Take Control**.
2. Press **Increase Flow** or **Decrease Flow** to run the control valve.



3. Press  or  to cycle the auxiliary valve. Press it again to return it to its original state.

## ISO Swath Control Module Diagnostics (Status tab)



The ISO Swath Module Diagnostics shows a lot of useful information about the sections. It shows what each section type is defined as. It shows the current state, on or off. Finally, it shows what pin each section is set to.

## ISO Swath Control Module Diagnostics (Control tab)

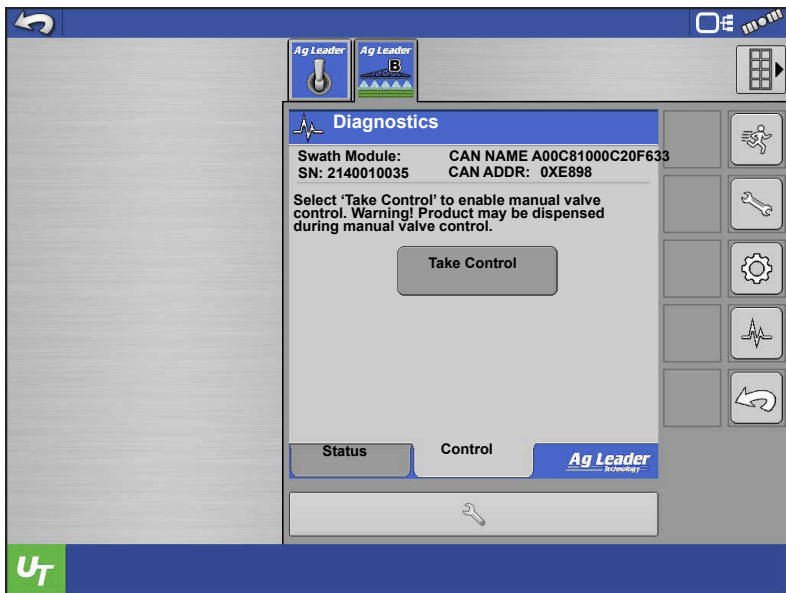

The Control tab will let the user take manual control of section valves.

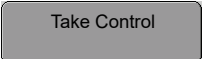
1. Press .

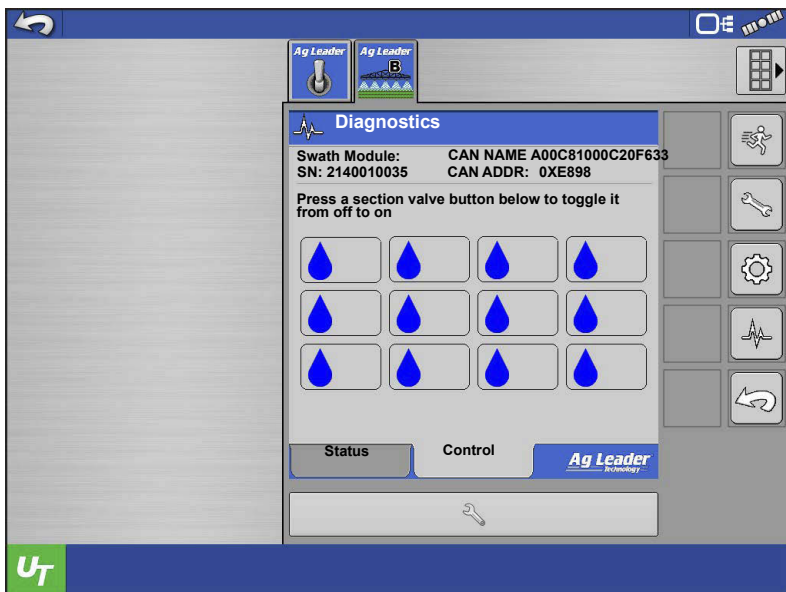

2. Press any of the section buttons to toggle them from off to on. Each section pressed should open and close as you do so.

## Alarms

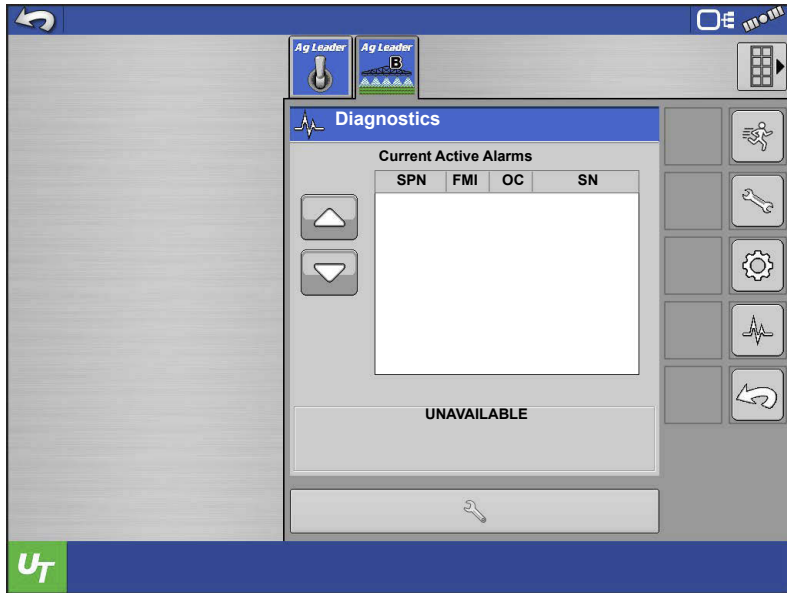

Any trouble codes or module errors will be displayed here. If present select one and provide the diagnostic information below to Ag Leader Technology Technical Support.

## Unlocks

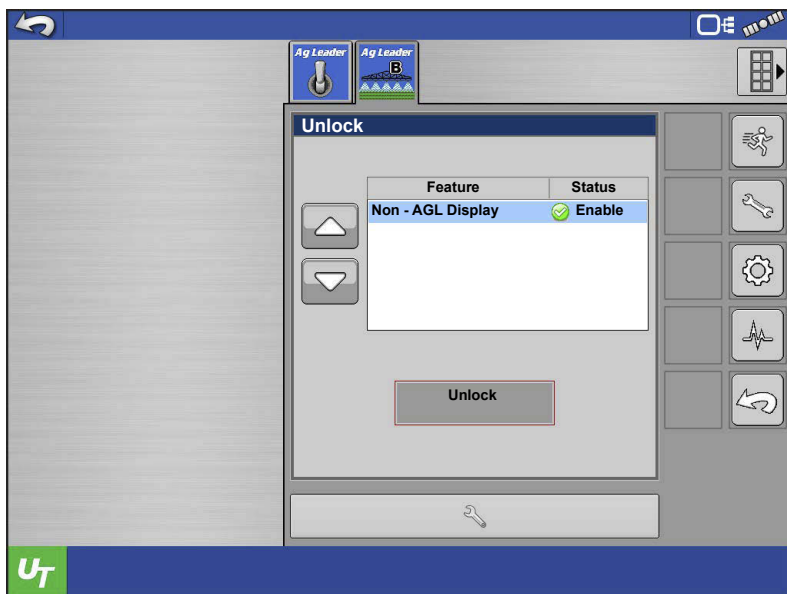



1. Select the unlock desired to be enabled.

2. Press  .

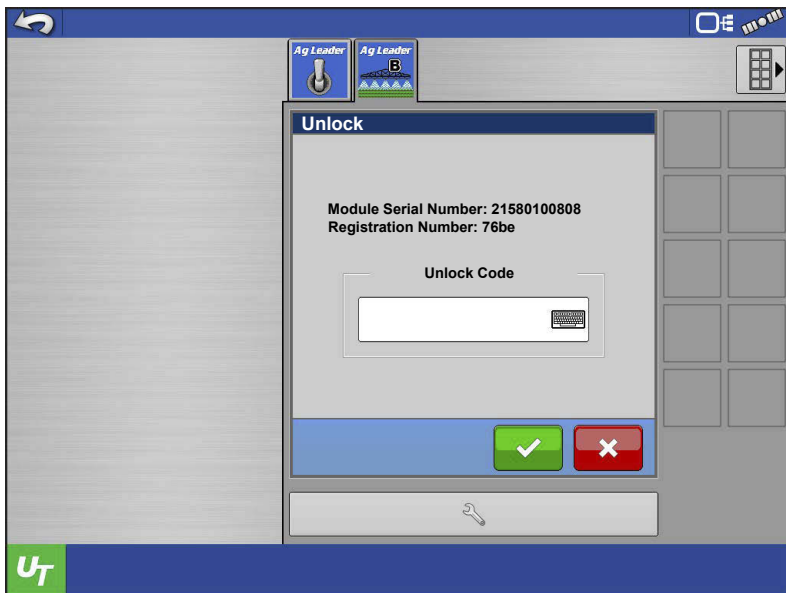



3. Provide the Module Serial Number and Registration Number to Ag Leader Technology Technical Support.
4. Enter the unlock code provided by technical support.
5. Press  to cancel, otherwise press  to save.
6. The unlock should now be displayed as Enabled.



## Tools

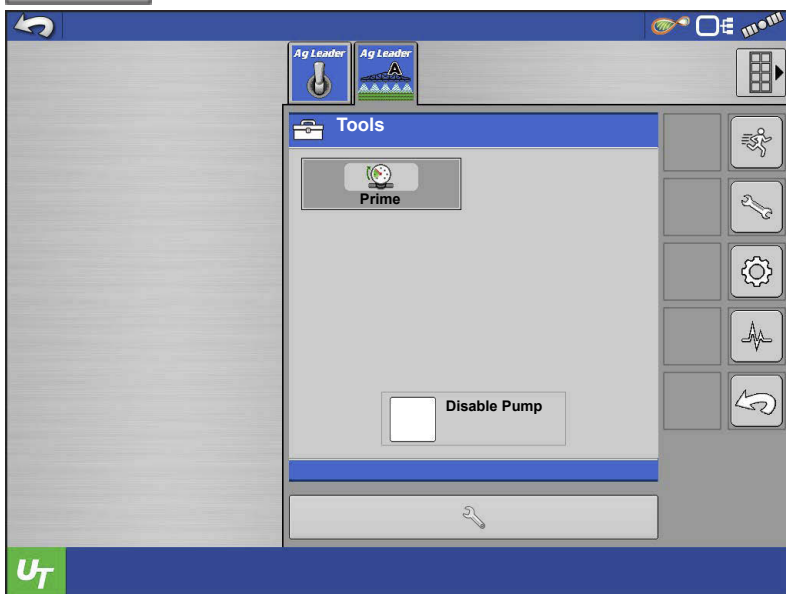

Tools contains the Prime feature for sprayer systems, and the Tube Check feature for Anhydrous Ammonia systems. It also contains the Direct Injection Diagnostics when an ISO Injection Pump is connected, and the Disable Pump feature for PWM control valve types.



**Prime**—This feature is only available with a PWM Control Valve type. It can also only be used with a pressure sensor on the system. Pressing the prime button will bring the system up to the defined Prime/Standby Pressure and hold it.



**NOTE!** The user will need to define a Prime/Standby Pressure under Pressure Settings for this to work.

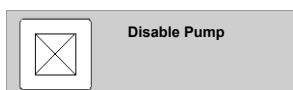

**Disable Pump**—When check marked the pump will remain off at all times. Unchecking will allow the system to control it normally.



**Tube Check**—This feature allows the operator to check for plugged knives or over-all obstructions with the toolbar raised. After pressing the Tube Check button, follow the on-screen instructions.



**NOTE!** The Tube Check button will only be available for Anhydrous Ammonia systems.



**Direct Injection**—Button will navigate you to the Direct Injection Settings (see below) accessible from the module.



**NOTE!** The Direct Injection button will only be available if a Raven ISO Injection pump is connected and setup in the active Profile.

**The Pump Enable /Disable**—Runs the Universal master switch for the pump. If it is checked the pump is enabled, unchecked the pump is disabled. This defaults to disabled at each power cycle.



**NOTE!** The ISO Liquid Switchbox master switch will turn the pump on and off while going through the field.

**Pump Flow**—Displays the current pump flow.

**Pump Mode**—Displays the mode the pump is set to (RX, Cal/Prime, Auto, Manual).

**Pump Target & Actual Rate**—Displays the pump's current Target and Actual Rate.

## ISO Liquid Module



Φ **High Power** – Indicates 12V high current power to the module

Status	Definition
Green	High Current Power OK
Red	No High Current Power
Off	No CAN Power
Blinking Yellow/Amber	Upgrading Module Firmware

LED 1 - Local CAN – Indicates if the ISO Liquid Module is communicating with the Swath Module

Status	Definition
Blinking Green	Local CAN BUS communicating with Swath module
Yellow/Amber	Local CAN BUS Error

LED 2 - Indicates if the ISO Liquid module is communicating with the connected display.

Status	Definition
OFF	No CAN Communication
Solid Red	CAN BUS Off
Solid/Blinking Yellow	CAN BUS Error
Blinking Green	CAN BUS Communicating

## Swath Module

Φ **High Power** – Indicates 12V high current power to the module

Status	Definition
Green	High Current Power OK
Red	No High Current Power
Off	No CAN Power
Blinking Yellow/Amber	Upgrading Module Firmware

---

LED 1 - Local CAN – Indicates if the Liquid Swath Module is communicating with the ISO Liquid Module

<b>Status</b>	<b>Definition</b>
Green	Local CAN BUS Communicating
Yellow/Amber	Local CAN BUS Error

LED 2 - Not used (always off)

### **ISOBUS Liquid Control–Pull Type/Toolbar**

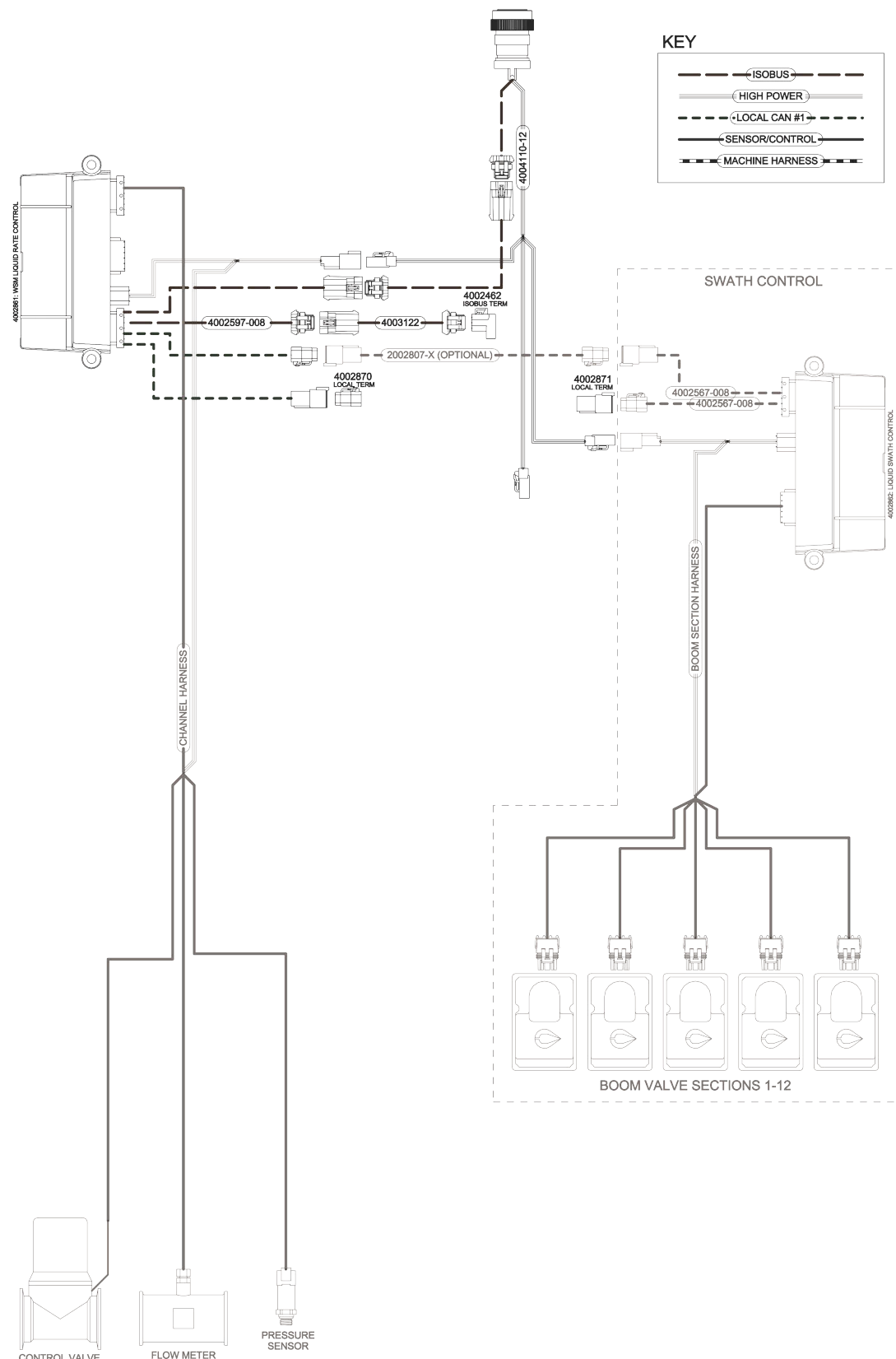

## ISOBUS Liquid Control-In-Cab

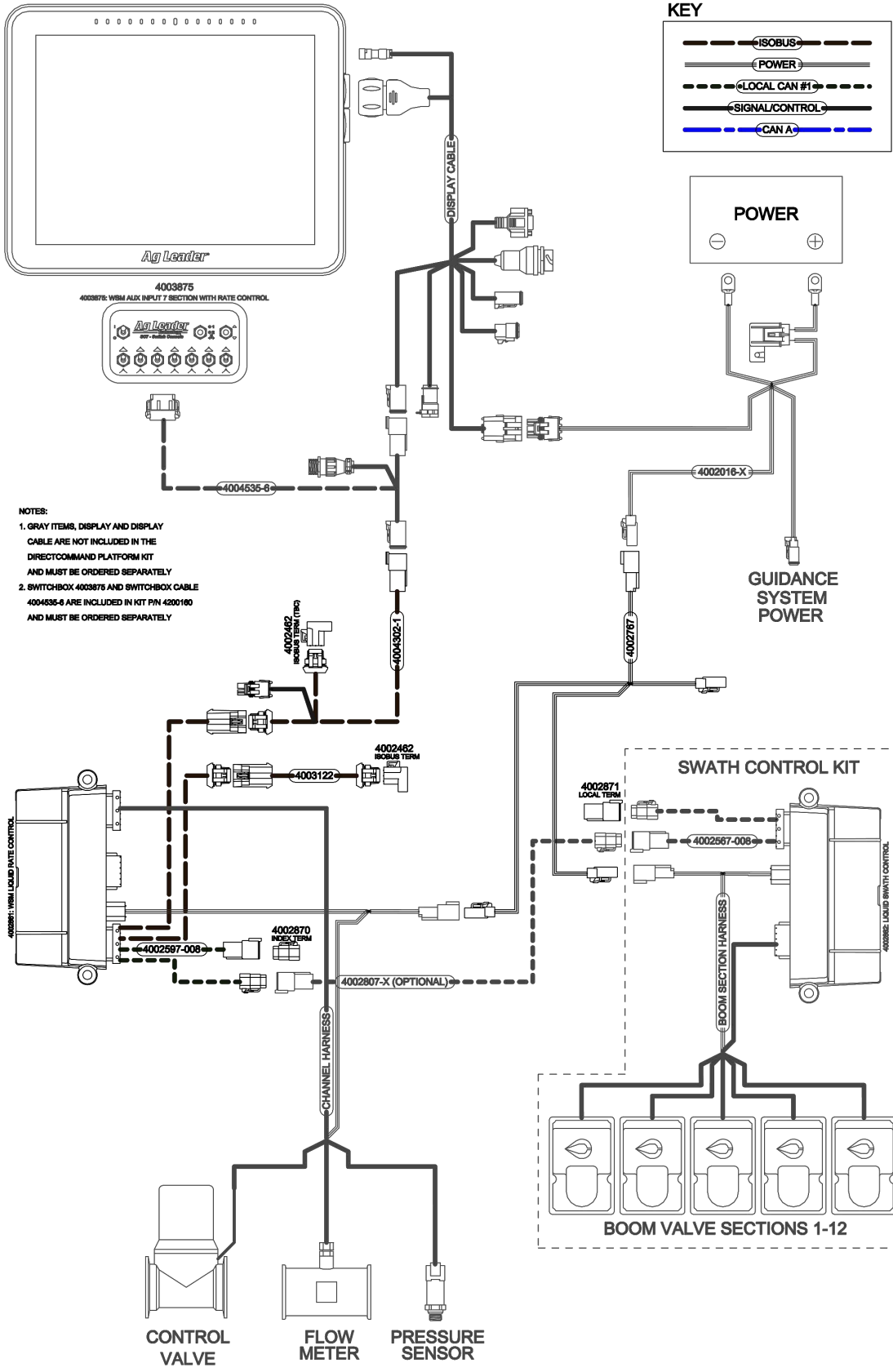

- NOTES:**
1. GRAY ITEMS, DISPLAY AND DISPLAY CABLE ARE NOT INCLUDED IN THE DIRECTCOMMAND PLATFORM KIT AND MUST BE ORDERED SEPARATELY
  2. SWITCHBOX 4003875 AND SWITCHBOX CABLE 4004535-8 ARE INCLUDED IN KIT P/N 4200180 AND MUST BE ORDERED SEPARATELY

## Load Configuration



Press the Application App from the home screen. This will take you through the steps needed to load a configuration.



**NOTE!:** For ISO Serial Application Rate module setup and settings, refer to pages [Enable Universal Terminal and Task Controller](#) on page 739 - page 748.

## Map View

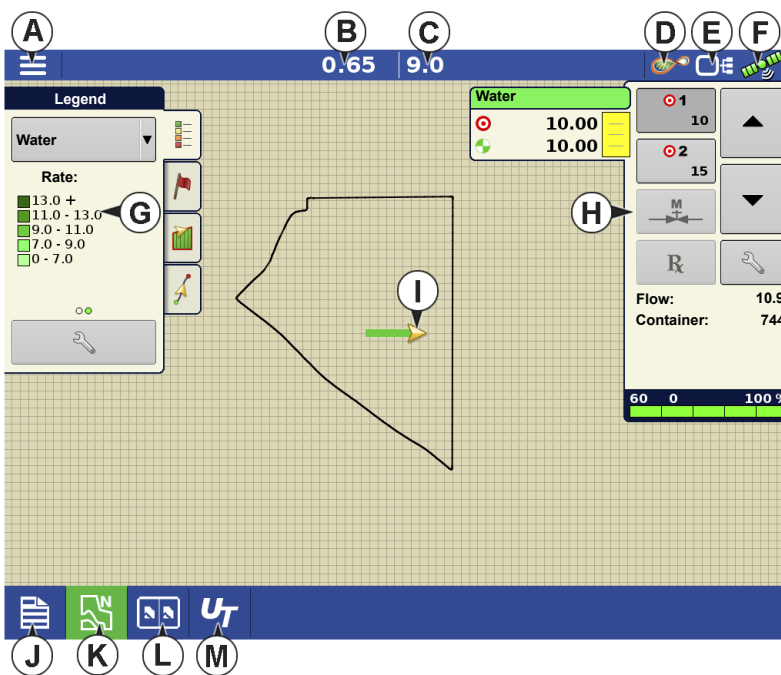

Once a configuration has been completed, the Map View screen appears.

- A. Menu button
- B. Total Logged Field Area
- C. Ground Speed
- D. AgFiniti® Status
- E. Diagnostics
- F. GPS Signal Indicator
- G. Display Legend
- H. Product Control toolbox

- I. Vehicle Icon
- J. Event Summary
- K. Map View
- L. Split screen
- M. Universal Terminal



**NOTE!:** Pressing the Map View button will cycle between the available Map screen views, and the appearance of the Map View button changes.

---

## Product Control Toolbox

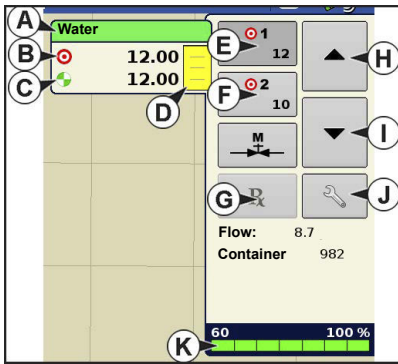

During DirectCommand™ Run Time operations, the Product Tabs are shown in the upper right-hand side of the Map screen. Press the Product Tabs, and an extended view shows the Rate buttons, Manual Valve Control button, Prescription button, Rate Increase and Rate Decrease arrows, and the Rate Setup button, all of which are described below.

- |                    |                             |
|--------------------|-----------------------------|
| A. Product         | G. Prescription button      |
| B. Target Rate     | H. Rate Increase arrow      |
| C. Actual Rate     | I. Rate Decrease arrow      |
| D. Container Level | J. Rate Setup button        |
| E. Rate 1 button   | K. Section Status Indicator |
| F. Rate 2 button   |                             |

**Target Rate**—The Target Rate is desired application rate.



**NOTE!** In some conditions, the Target Rate may increment more quickly than the Actual Rate.

**Actual Rate**—The Flow Sensor returns the actual rate being applied.



**NOTE!** In some conditions, the Actual Rate may increment slower than the Target Rate, or its numeric values may vary before matching the Target Rate.

**Container Level**—The Container Level shows the amount of product in the container.

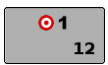



**Rate 1 and Rate 2 buttons**—The Rate 1 and Rate 2 settings represent preset application rates that allow operators to quickly change between desired target rates for each individual product.



**Manual Valve Control button** — (Not Available for this Operation) The Manual Valve Control button allows operators to specify the position of the control valve. Operators use this option to prime the system before application or clean out the equipment at the end of the day.



**Rate Increase and Decrease Arrows** —  /  allow Product Application Rate to be changed according to the Target Rate Increment. In using manual valve control, the increase and decrease buttons allow the position of the control valve to be defined by the operator.

**Prescription button**— 

**Rate Setup button**— 

## Rate Control Settings

 Adjust the Rate 1 and Rate 2 settings shown at the Product Control Toolbox on the Map screen, as well as import application product prescriptions. To access the Rate Control Settings screen, press the Rate Setup button on the Product Control Toolbox. The Rate Control Settings screen appears.

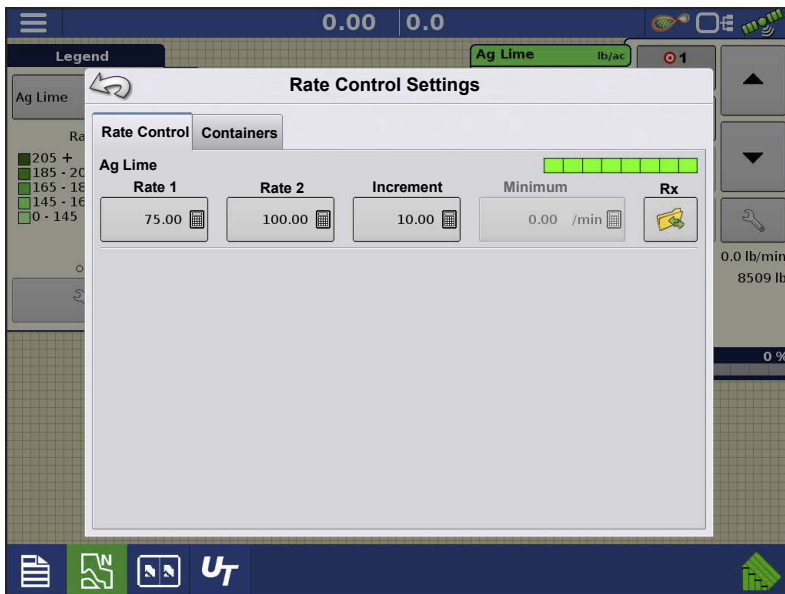

**Rate 1 and Rate 2** — The Rate 1 and Rate 2 settings represent preset application rates that allow operators to quickly change between desired target rates for each individual product. Press  to enter the desired amount.

**Increment** — The Increment button allows operators to specify the increase or decrease amounts for a

specified rate by using  /  on the Product Control Toolbox. Press  to enter the desired increment.

**Prescription** — To load a map-based prescription file, press the Prescription button.

**Minimum Flow** — (Used for DirectCommand Liquid Applications only). This setting is used to maintain a consistent spray pattern. The display will not allow flow to drop below the entered setting. Set to flow at the lowest operating pressure for the selected spray tips with all sections on. When spraying with one or more boom sections off, the system automatically reduces the

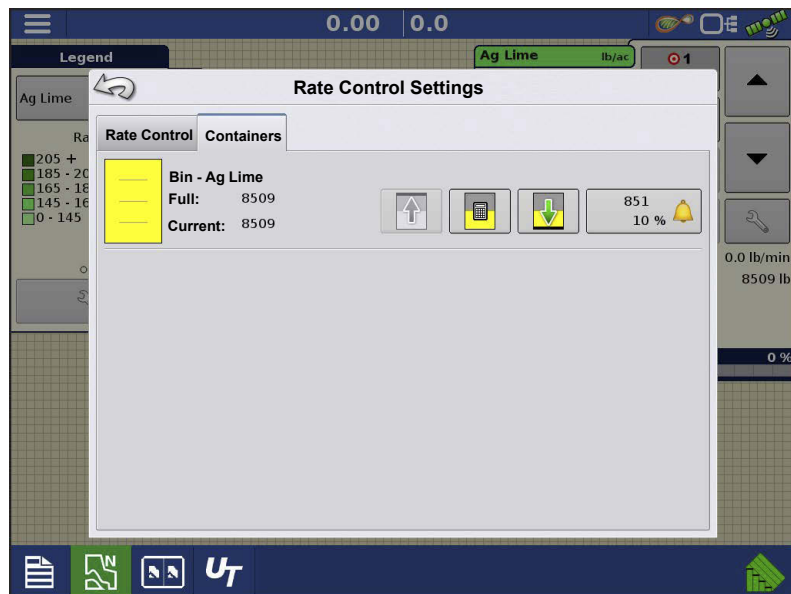

minimum flow setting according to the reduced spray width. To adjust this setting, press  and enter the desired numeric value.

## Container Level Settings



When filling or emptying container, use the Container Level portion of the Rate Control Settings screen to update the amount of product in the containers.

Container Level screen

-  •**Tank Fill** — The Tank Fill button increases the container level logged in the display to the user-defined maximum volume (specified in the Container Setup Wizard).
-  •**Tank Empty** — The Tank Empty button decreases the container level logged in the display to zero.
-  •**Tank Partial Fill** — The Tank Partial Fill button increases the container level logged in the display to specific amount that you specify by pressing calculator icon. Pressing the Partial Fill button summons the Adjust Container Amount screen.

## Adjust Container Amount

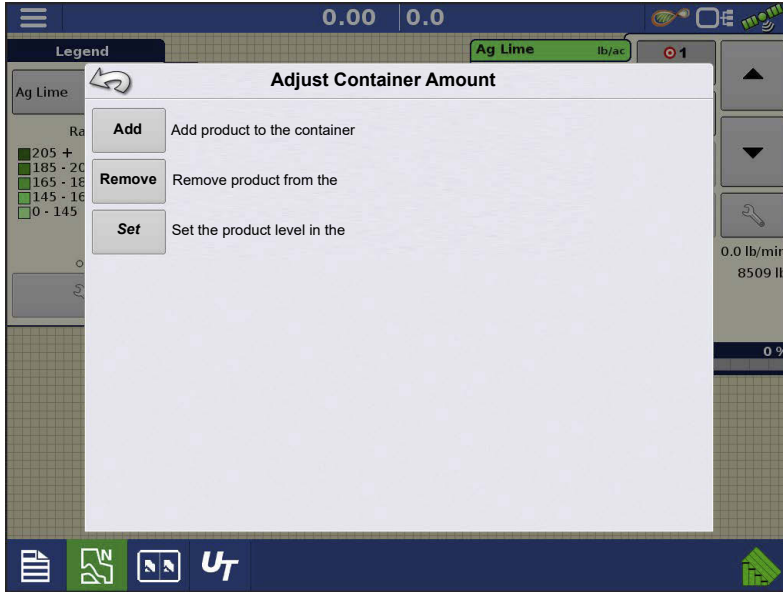

- **Add** — Adds product to the container.
- **Remove** — Removes product from the container.
- **Set** — Sets the product level in the container.

## Tank Alarms

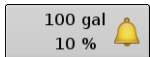

The Container Alarm button, which appears on the right of the Container Level portion of the Rate screen, displays the capacity of your tank as well as the percentage at which the Low Container Level warning will sound. To adjust these settings, press the button and the Container Alarm screen appears.

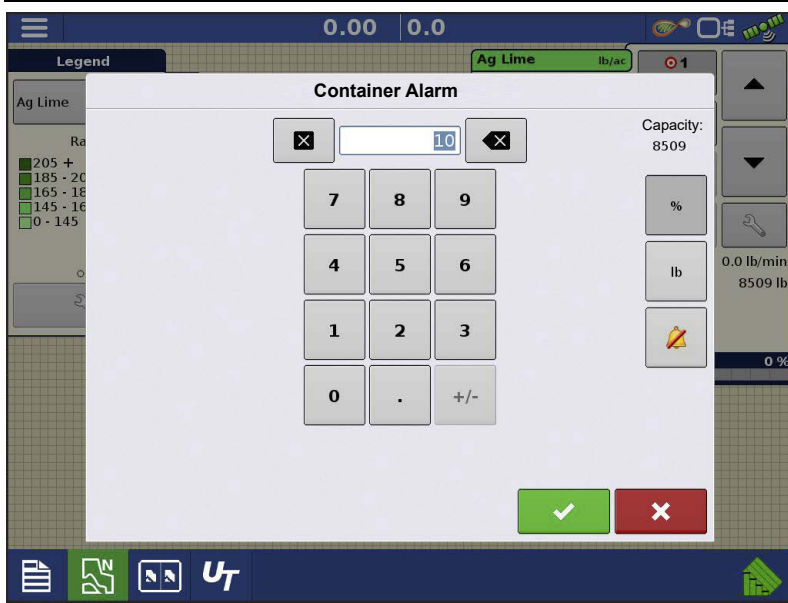

If you wish to adjust your container level warnings, use the following buttons on the right-hand side of the Container Alarm screen to make these adjustments.

The **percentage (%)** button sets the warning threshold according to the percentage of solution left in the tank. In the example above, the threshold is set at 10 percent.

The **units of measurement** icon sets the warning threshold according to the amount of solution left in the tank. This icon is named according to the container's units of measurement you specified during the Controller configuration procedure.

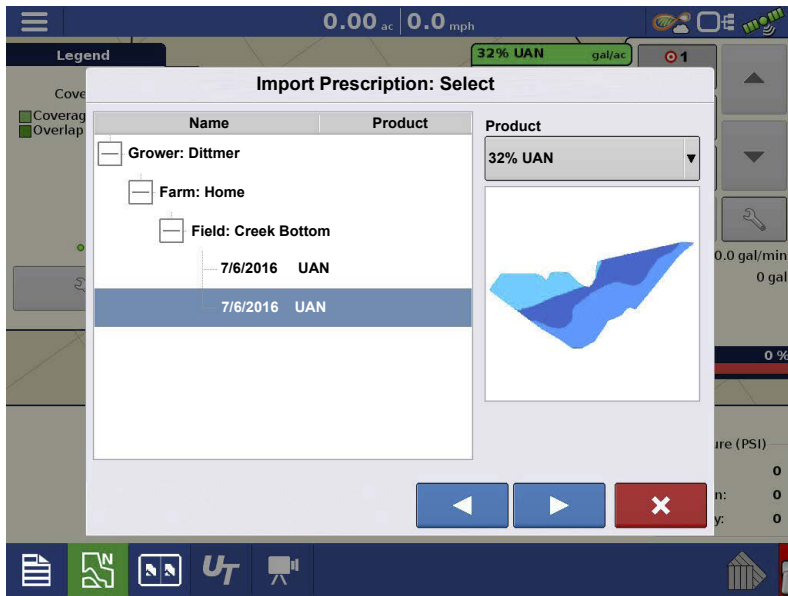

The **Disable Low Container Level** button, which appears as a bell with a red slash across it, disables the Low Container Level warning.

## Loading Prescriptions



1.  Press the Rate Setup button on the Product Control Toolbox.

2. Press the Load Prescription button.

3.  Using an inserted USB or AgFiniti Cloud, search for and highlight the correct .agsetup, .irx, or shape file and press .

4. Select the prescription in the Select Prescription screen, and select the correct controlling product from the Product dropdown box. A preview prescription map is displayed. Press .

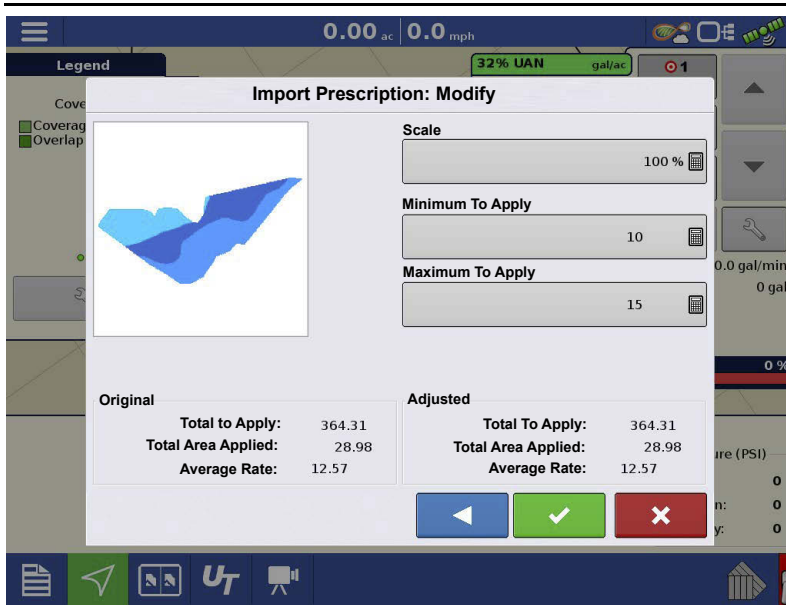

5. In the Modify Prescription Screen the prescription scale, minimum to apply, and maximum to apply can be changed. As the three parameters are changed, the adjusted total to apply and average rate will update accordingly.

6. Press the .

7. After returning to the Mapping Screen, the prescription will appear on

the map while in a North Oriented view.

## Shape File Conversion

What is commonly called a shape file is actually a collection of three different files. All three of the files are required and must be present on the USB drive for the system to use shape file groups for variable rate product application. A single "shape file" can contain recommendation rates for multiple products.





1. To begin, press the Rate Setup button on the Product Control Toolbox.

The Rate Control Settings screen appears

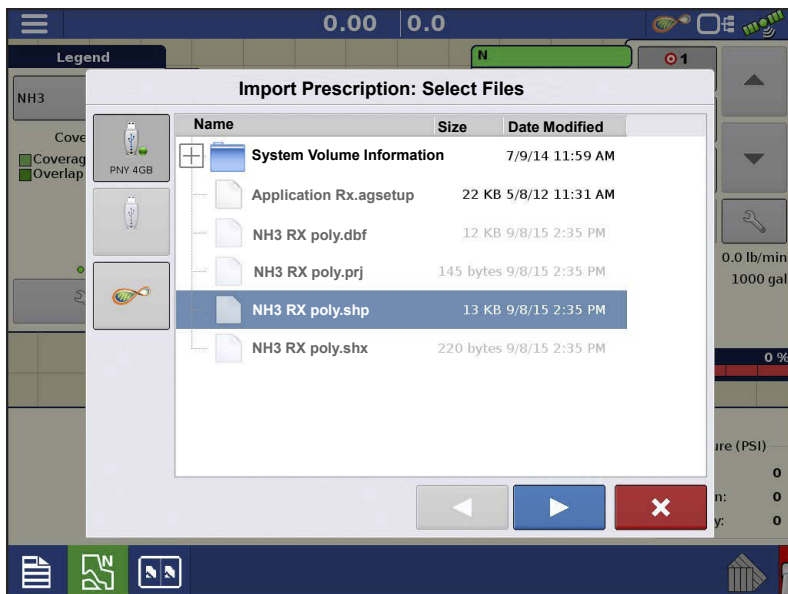

2. Press the Load Prescription button.



3. The Select File screen appears. Highlight your desired .shp file and press .

4. Select Column From Shape File

Select the column that contains the product recommendation rate. The list on the right side of the dialog shows sample data from the selected column.

## 5. Select Units

Select the controlling units for product application.

## 6. Default Rate Setting

The system assigns a default rate. Use the on-screen keypad to edit the value if desired.



**NOTE!:** Select the product and units that the shape file prescription was made for. Selection of the wrong data column or unit will result in misapplication of product.



**ATTENTION!:** The only time the default rate is used by the system during product application is if the Rate Outside of Field selection is set to "Rx default". This setting is located in the equipment configuration settings portion of configuration setup. If the Rate Outside of Field selection is set to "Rx default", the default target rate will be used when the vehicle exits the area covered in the prescription map.

## Creating Products

Creating application products and product templates can be completed during initial setup or from the Product Selection screen of the Field Operation Wizard when starting a field operation.



**NOTE!:** Creating products for your operation may differ than was it documented in this section. It will depend if you serial controlled application is liquid or granular.

## Creating Single Products

To create a single product, to be added to a product template or to be applied by itself, use the on-screen wizard described in the following steps.



Select:

1. Product Type
2. Product Units

---

### 3. EPA Product Number (Optional)

Check box if product is a Restricted Use Pesticide

### 4. Manufacturer name if applicable.

Manufacturer name can be added to the drop-down menu by pressing .

### 5. Press to enter a unique name for the product.

Created product should appear under the Application heading located on the Product tab of the Configuration Setup screen.

 **NOTE!:** Some Fertilizer and Carrier product types are predetermined in the display. These product names cannot be edited. Their Manufacturer and EPA Numbers can be edited after the product is created. Examples are: Fertilizer>DAP or Carrier>30% UAN.

## Creating Product Templates

Product Templates are set up by using the on-screen wizard.

 **NOTE!:** Prior to making a new product template, it is recommended to add the individual products to the list in the units recommended by the chemical label.

It is recommended to create product templates that contain the products applied for a crop type or time of the season.

Examples are:

- Pre-Emerge Burndown
- Post-Emerge Corn
- Post-Emerge Beans
- Insecticide
- Fungicide

In each template the products can be checked on/off for the mix when loaded at the run screen.



### 6. Select Tank Mix

---



---

## Define By

- Total amounts - mix/blend defined by amounts added to the tank (total of each product in tank)
- Rate/acre - mix/blend defined by the amounts applied per acre (rate of each product applied/area)

### 7. Enter a Base Amount or Base Rate and Units.

- Total Amounts - Tank/Bin Size
- Rate/Acre - For Rate Applied per Acre

### 8. Select Carrier



- Press  to create a new carrier.

### 9. Press by the Add Mix/Blend Contents box to start the process of adding components to the mix.

### 10. Select the desired component from the drop-down menu.



**NOTE!:** More than 7 products can be part of a template, but only 7 or fewer can be active at the same time.

- A new product can be set up at this time by pressing (+ icon) and following the Product Setup Wizard.
- Press  to add selected product, or press  to return to Add Mix/Blend screen without adding a product.



### 11. Press to add an additional product.

### 12. When all components have been added press .

### 13. Enter Manufacturer name is applicable.

- Manufacturer name can be added to the drop-down menu by pressing .

### 14. Press to enter a unique name for the mix/blend.

- 
- Press  to complete the process of setting up the mix/blend, or press  to return to the Configuration Setup screen without adding a mix.

The product mix/blend appears under the Application heading located on the Product tab of the Configuration Setup screen.



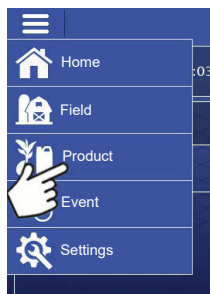

Represents Product Templates

## Configure Product Mix

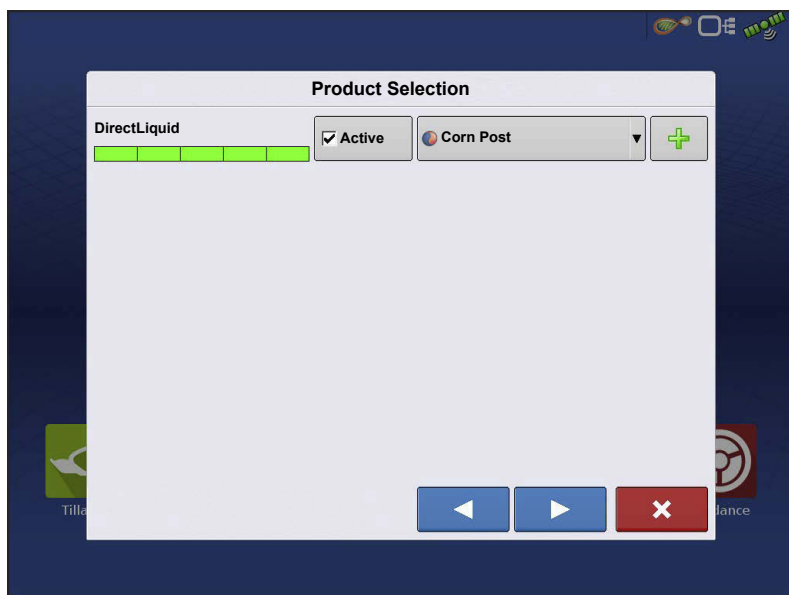

When using a product template, the mix contents and amounts are defined in the Configure Product Mix screen available in the Event Setup Wizard, or Product button in the main menu.



1. Select your mix/blend from the drop-down list or press  to create and new mix/blend.

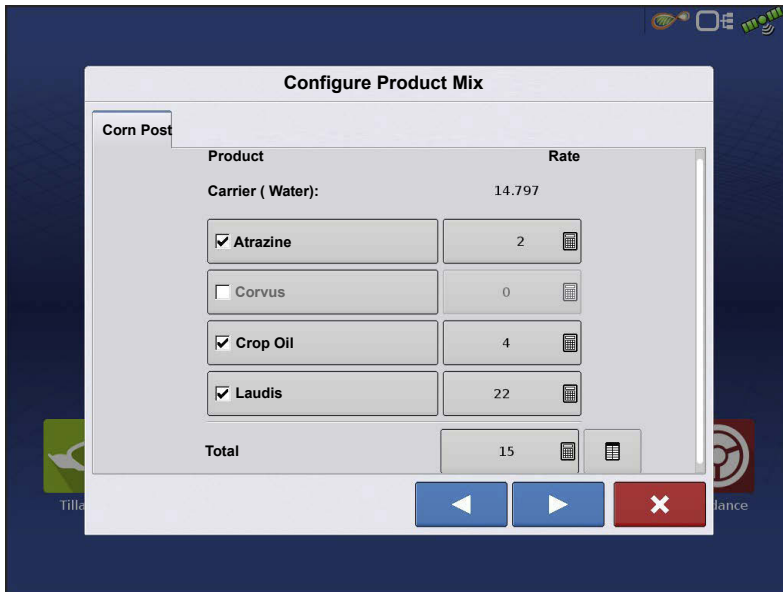

2. The product template mix contents and amounts are defined by:

- a. activating or de-activating products
  - b. changing rate or total amount of product
  - c. changing total amount of the product or overall rate of product application
- A product can not be active with a rate

of zero. Press  to access the Mix Calculator.

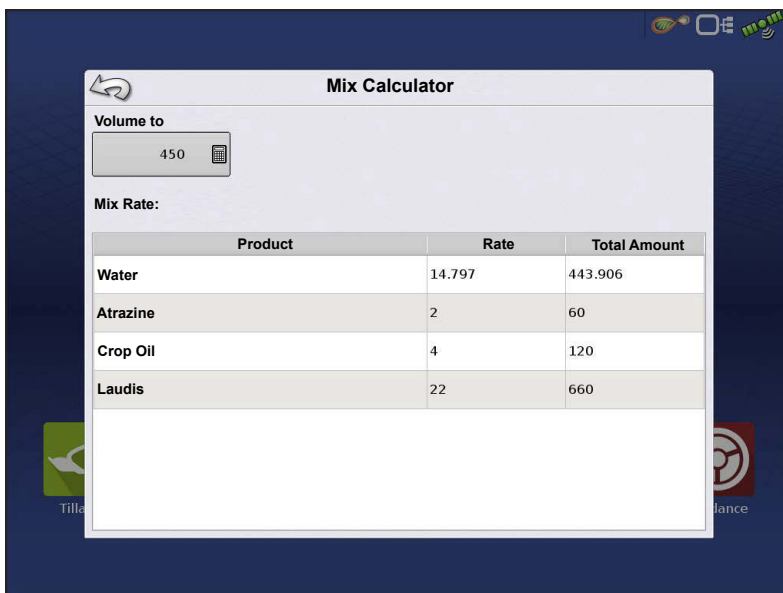

2. When a product template is setup using rate/area, the Mix Calculator can be used to show how much of each product to put in the tank when the user enters the desired amount to fill.

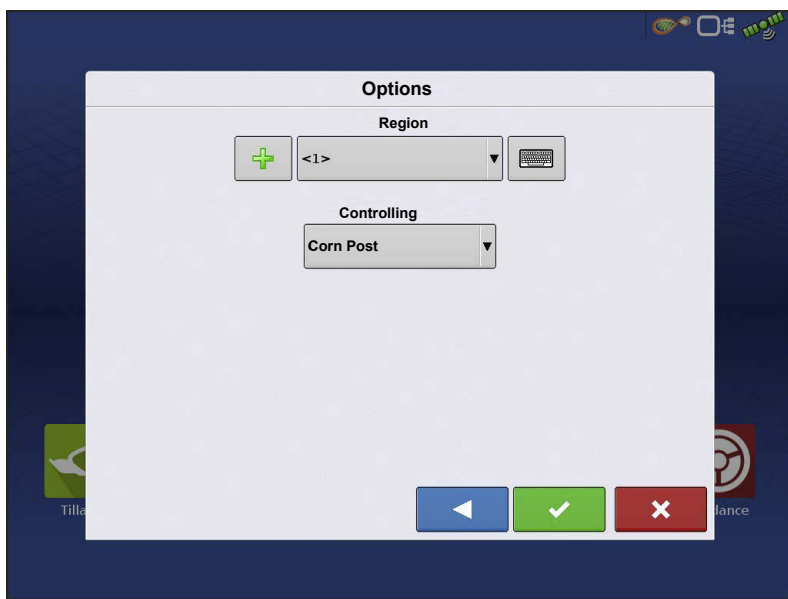

3. Press the Volume to Calculate button and input the total volume. Table will give the user the amount of each product to put in the tank.



4. Select Region from the drop-down menu or press  to name Region. Verify the Controlling Product for the Mix/Blend.

Press  to load the Event to the Map Screen, or press  to return to Home screen without setting up an Event.

## Create Configuration

To create a configuration, make the following button presses to start the Configuration Wizard and then follow the instructions given on the display. The configuration can be started in two places:



OR



OR



## Load Configuration



Press the Application operations button from the home screen. This will take you through the steps needed to load a configuration.

## Implement Offsets

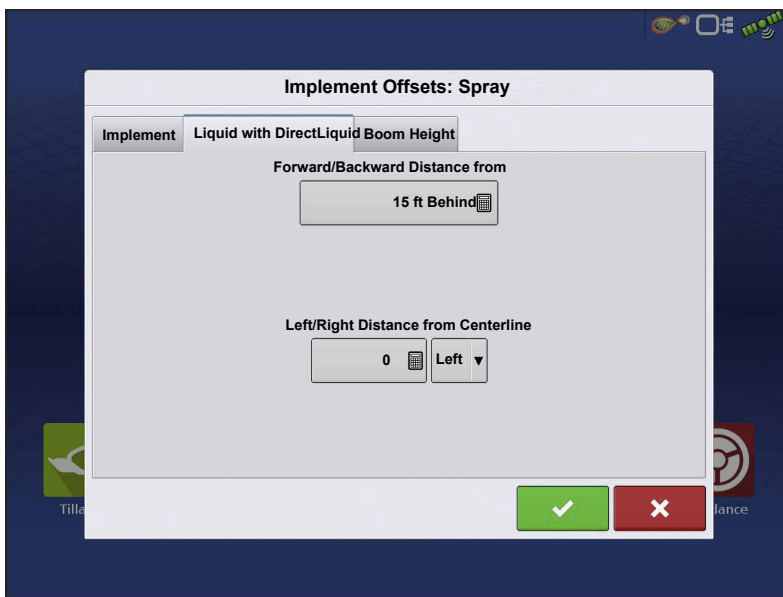
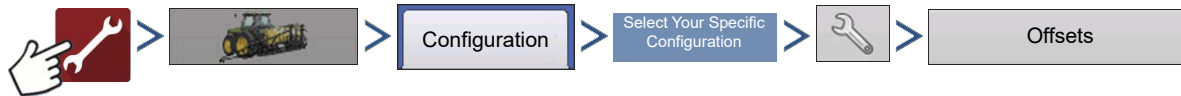

Implement Offsets screen appears, with each channel's settings shown on its own tab.

Defaults to the value entered during Configuration Wizard

Boom sections can independently be offset forward or back (Application Operation only)

1. Press  to access Swath Section Offsets screen.

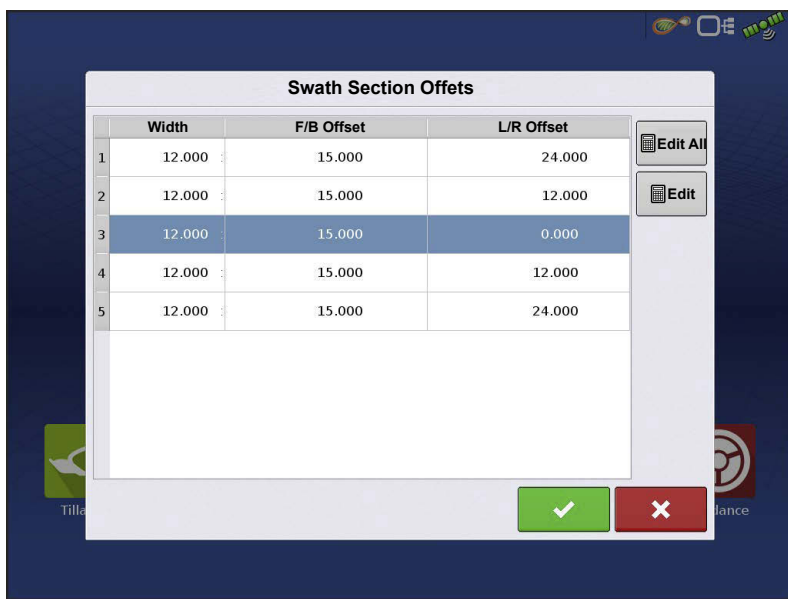

2. Select Swath section to edit and press Edit button.

3. Enter Offset for that specific section and Forward/Backward from rear axle.

4. Press  to enter change.

Setup will indicate which offset is entered

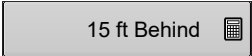
 **Global**—All

sections have the same offset.

 **Individual**—At least one section has a different offset.

Individual—At least one section has a different offset.

Runscreen reflects section offsets

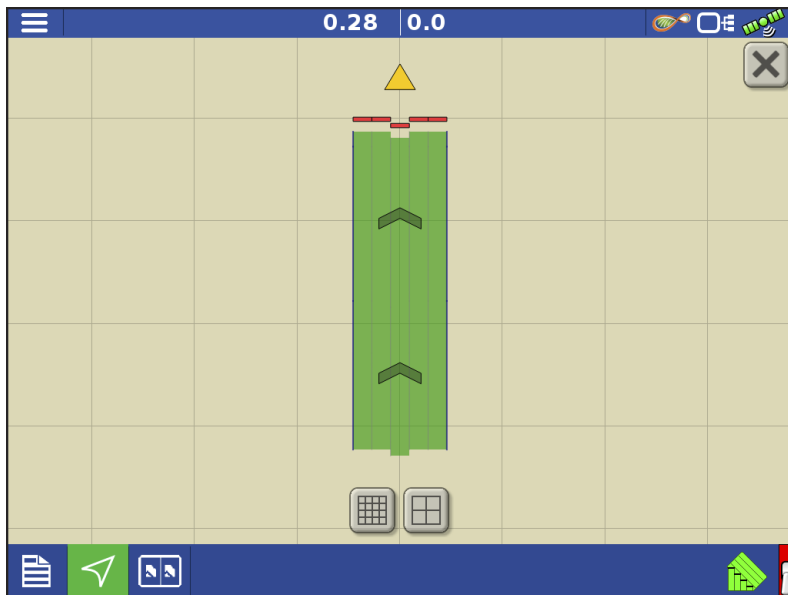

## Equipment Settings

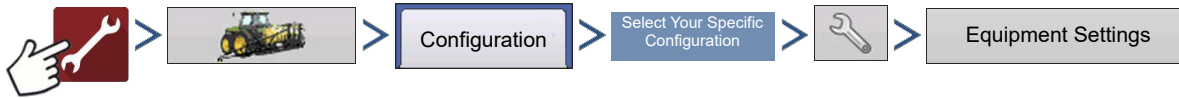

OR

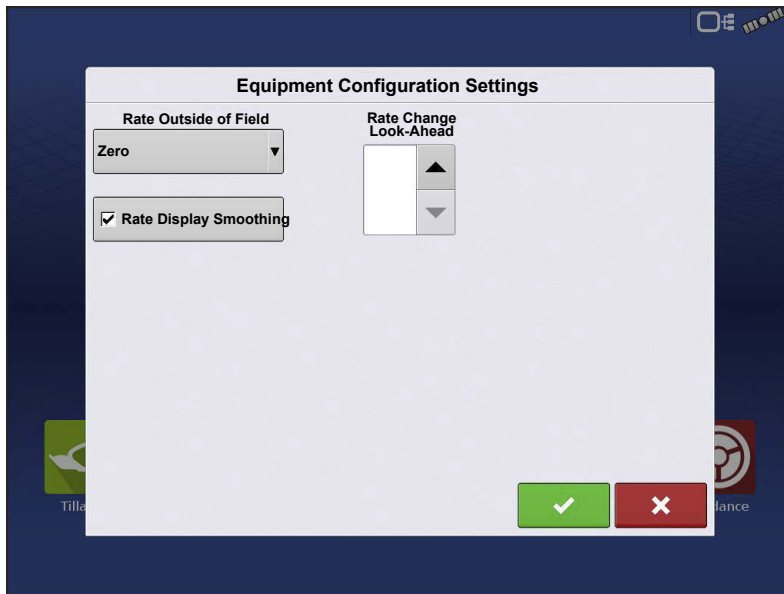

**Rate Outside of Field**—This setting will define how product will be controlled when leaving a field boundary.

**Zero**—This will stop application.

**Last Good**—This will continue application at the last known rate.

**Rx Default**—When using a prescription, this will apply at the Default Rate (or outside of boundary rate) as defined by the prescription file.

**Rate Display Smoothing**—

Determines how the feedback from the control channel rate sensor will be displayed on the map screen. When de-selected, the system will display raw feedback from the rate sensor. When checked, the system will display target rate when the application rate is within 10% of the target rate setting.

**Rate Change Look-Ahead**—This setting compensates for any latency in the control system when changing between different product flow rates during variable rate application. The typical setting range for this is 0-1 seconds. This setting can be thought of as a “look ahead” value when using a variable rate prescription. The display will send the signal to change rates before hitting a transition line so that the applied rate is correct when crossing into the new management zone.

## Enable Universal Terminal and Task Controller

To enable the Universal Terminal:

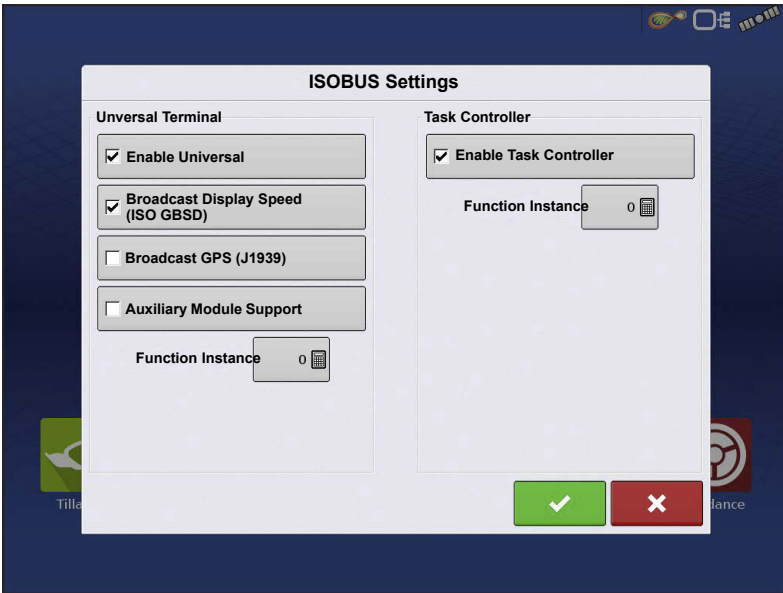
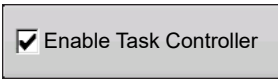
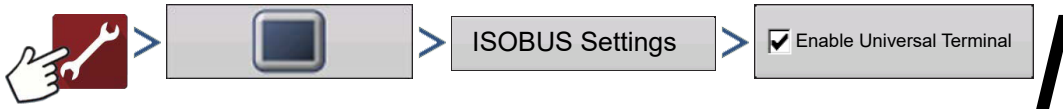

Once a Universal Terminal has been enabled

 will appear in the task bar.

Toggle between the Universal Terminal run screen and other display functions by pressing the UT button.

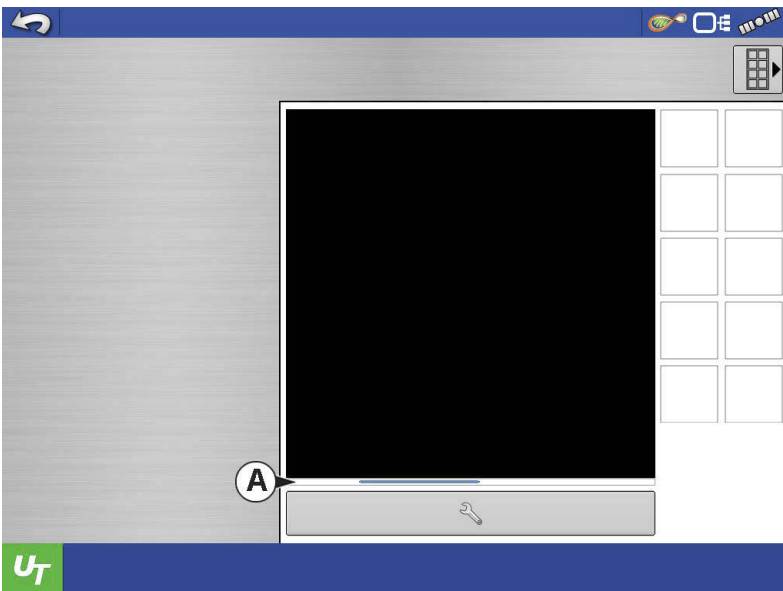

Status Bar (A) appears while Object Pool is in the process of loading.



## Configuration Setup

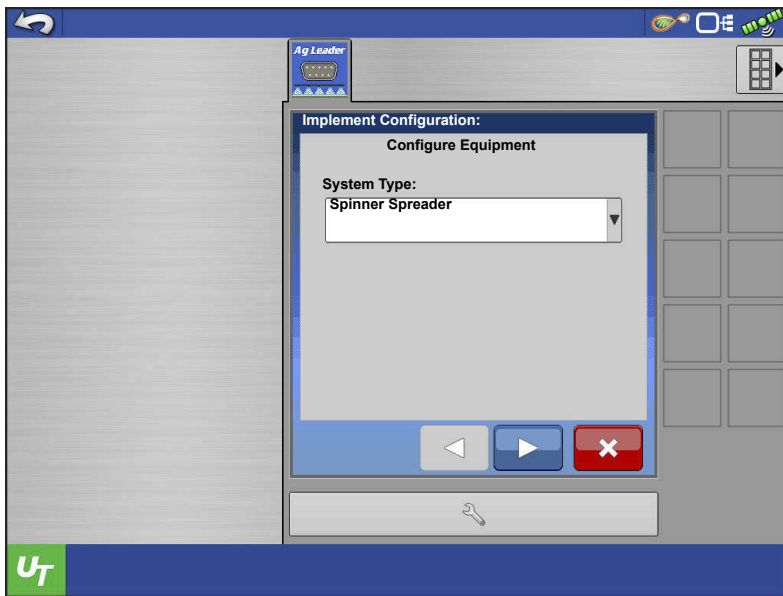

**i NOTE!** The user will have to setup a configuration for the Task Controller also.

1. Use drop-down menu to select the System Type

- Sprayer

- Spinner Spreader

- Seeder

- Row Crop Planter

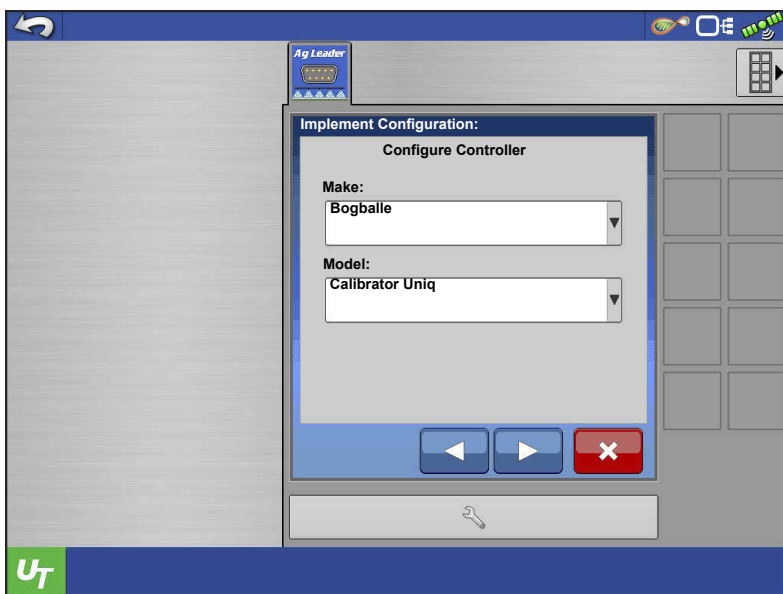

2. Use drop-down menu to select Controller Make and Model.

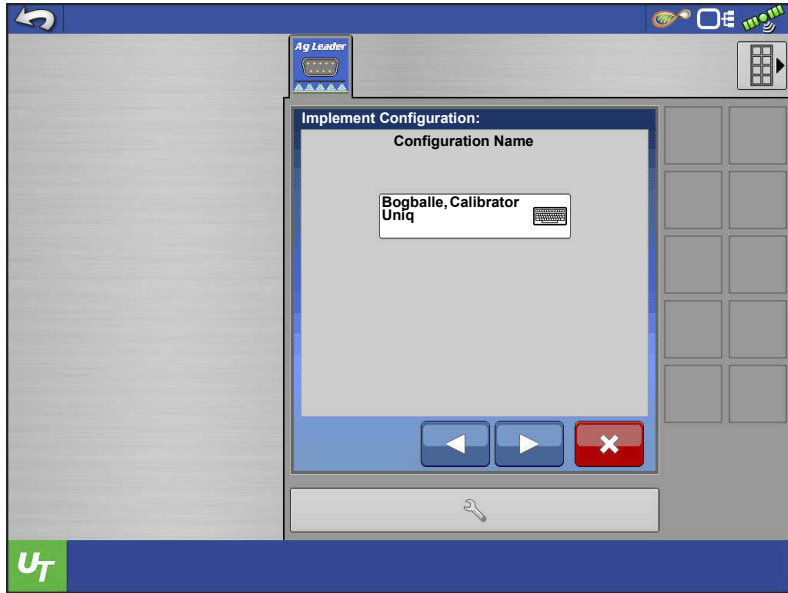

3. Use keyboard to enter the Configuration Name

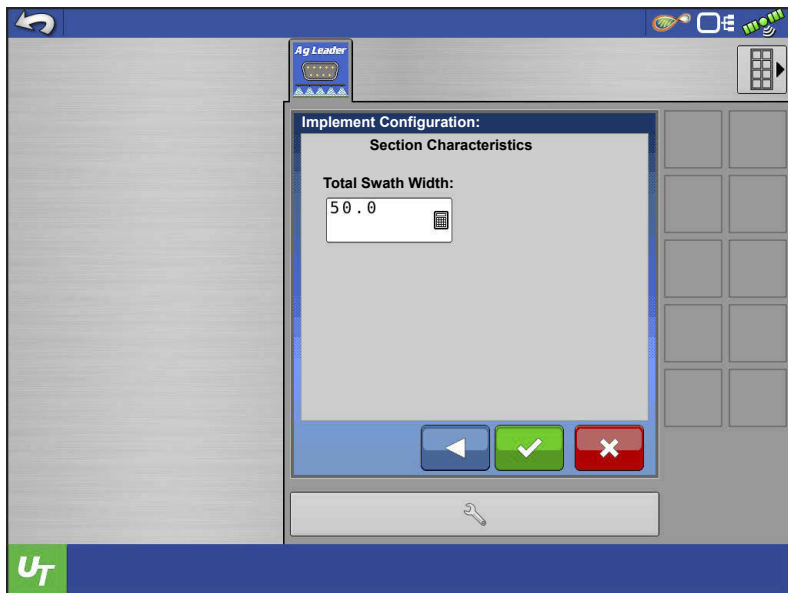

4. Use keypad to input the total swath width.

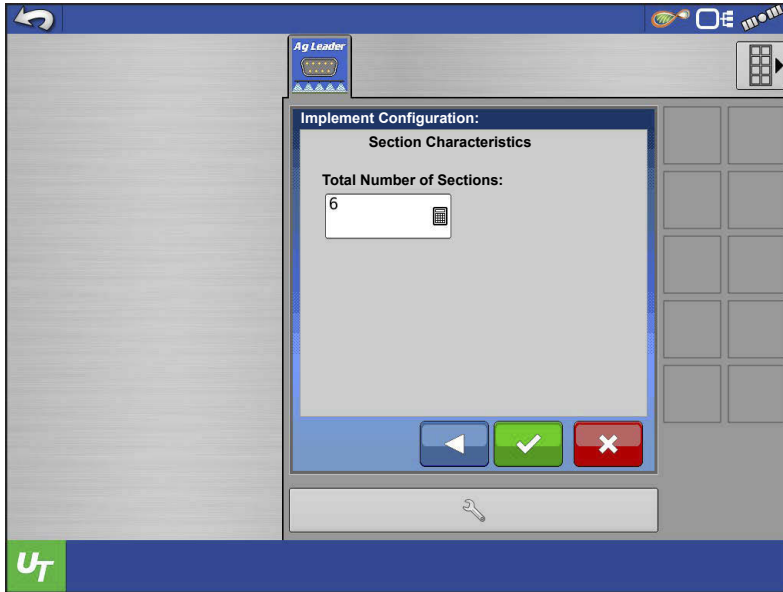

 **NOTE!:** Depending on the controller selected, user may be prompted to enter **Number of Sections** or **Nominal Rate** and **Percentage Rate Change**.

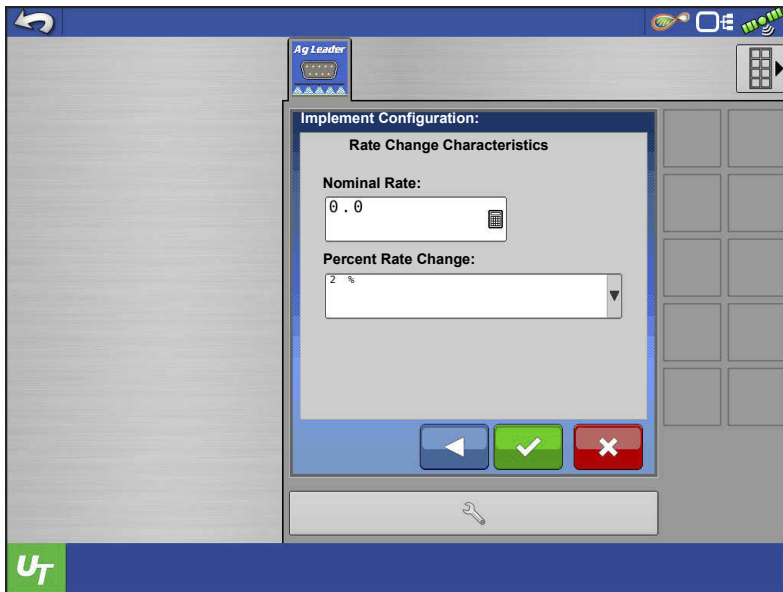

 **ATTENTION!:** Nominal Rate and Percent Rate Change must equal the corresponding values in the controlling display.

# Status Screen



The status screen provides the user with readout of the connected controller's target rate, actual rate, section status, and connection status.

**NOTE!** The target rate is not available for edit from the UT screen. Target rate can only be adjusted from the Run Screen.

**NOTE!** Some controllers allow users to increase the target rate by an

increment amount of their own. The ISO Serial Bridge module will not know that the Target Rate has changed and may trigger a Rate Not Responding Alarm. To avoid this, use the increment increase/decrease function within the Ag Leader display.

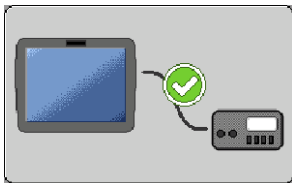

**Serial Connection Status** – Indicates if the ISOBUS Serial Application Rate module is communicating with the connected controller.



**Target Rate Status** – Indicates the target rate sent to the connected controller.



**Actual Rate Status** – Indicates the actual rate received from the connected controller.

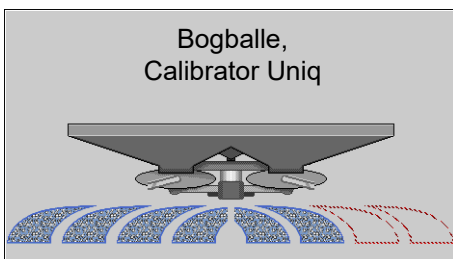

**Boom Section Status** – Indicates the on/off status of the sections sent to the connected controller.

Red = section off

Blue = section on



**ATTENTION!:** Speed is not being communicated to the controlling display. An external speed source must be supplied to the controller.

# Settings Screen



Press the Settings button.

## Manage Configurations

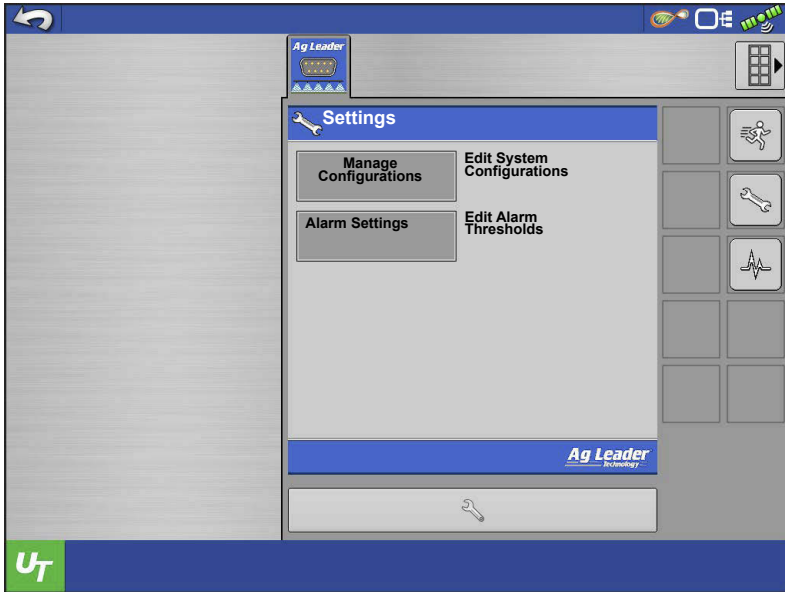

Press **Manage Configurations** button to edit system configurations.

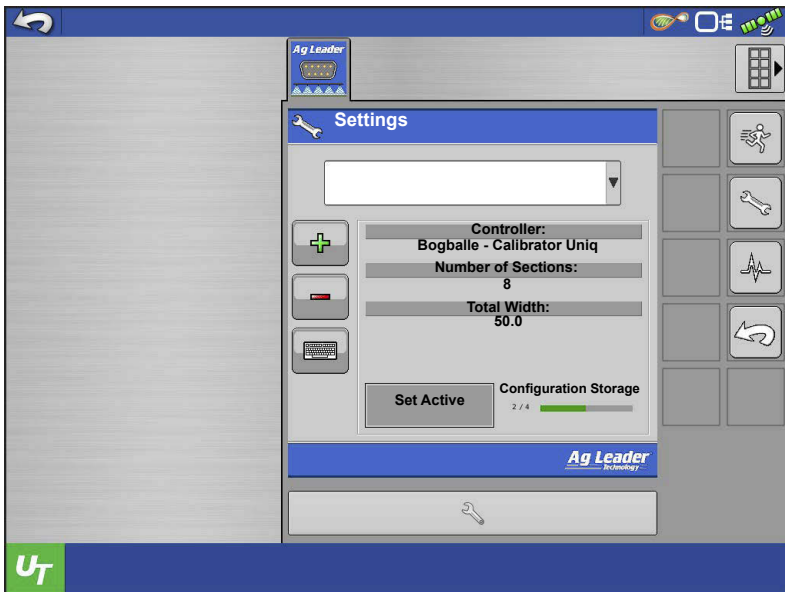

A user can add, remove, edit, or select an active configuration. The module will save up to 4 configurations.



**ATTENTION!** Always verify that the Active controller in the Universal Terminal matches the configuration being utilized on the displays run screen.

## Alarm Settings

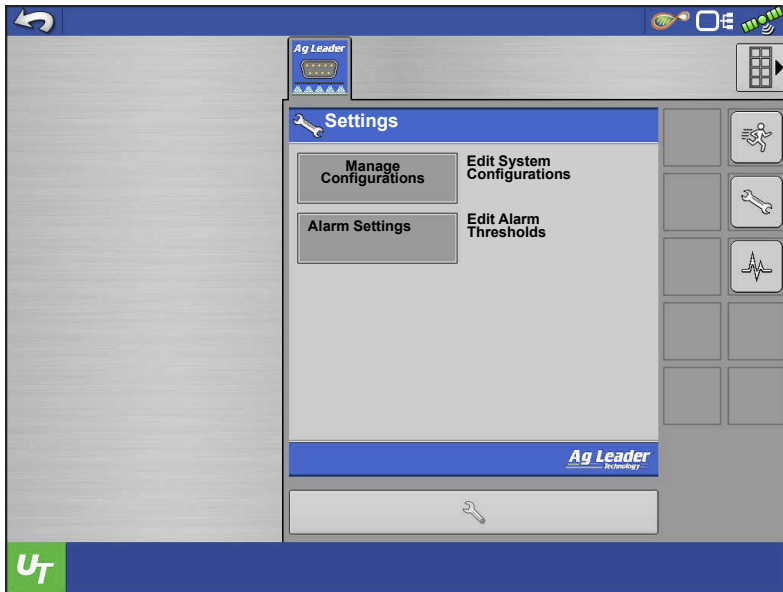

Press **Alarm Settings** button to edit alarm thresholds.

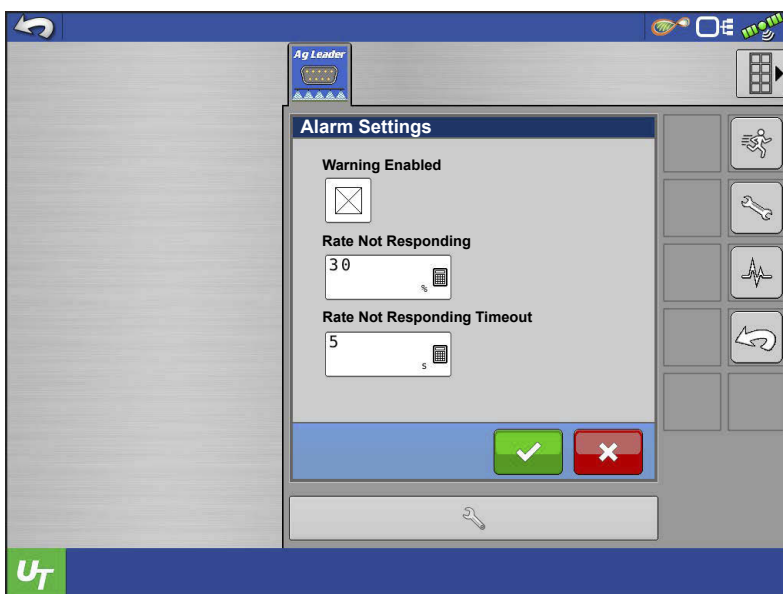

**Warning Enabled** – With this setting enabled, the user will get a “Rate Not Responding” alarm when the actual rate does not fall within the threshold and timeout settings. The user will not receive an alarm if this setting is disabled.

**Rate Not Responding Threshold** – This setting defines the percent value the actual rate can be off from the

target rate and not trigger the “Rate Not Responding Alarm” alarm.

**Rate Not Responding Timeout** – This setting defines the amount of time the actual rate can fall outside the Rate Not Responding Threshold without triggering the “Rate Not Responding Alarm” alarm.

## Diagnostics

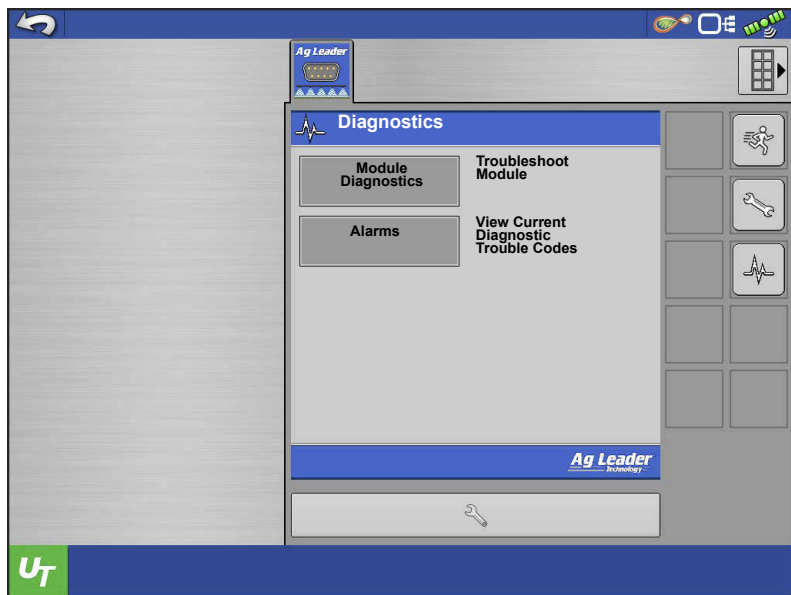

Press Diagnostics button.

**Module Diagnostics** – Contains module diagnostic information to assist in troubleshooting.

**Alarms** – Contains any active alarms from the module.

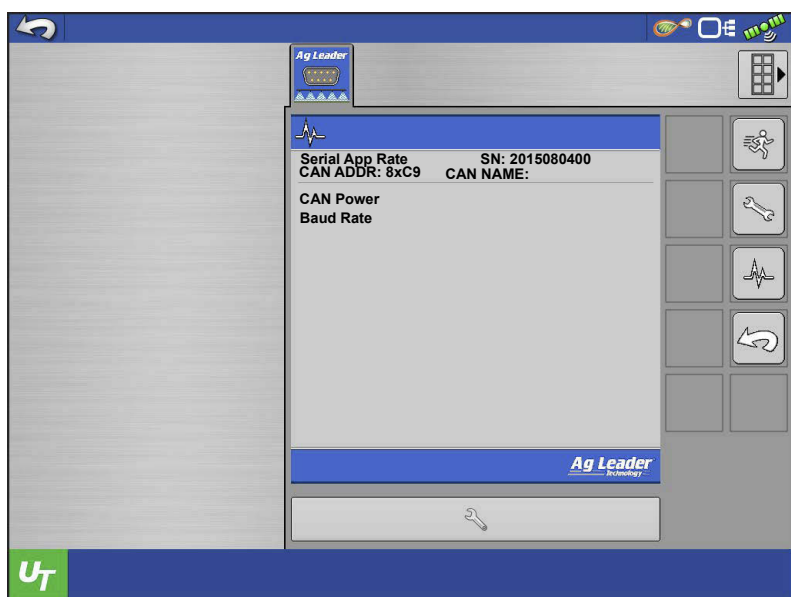





---

## Troubleshooting Serial Control Applications—Liquid

**Problem:** Rate changes on the display, but not on the controlled console.

**Solution:**

1. Verify the current firmware is running on the display and Serial Application Rate module.
2. Check the settings specific to your controlled console.
3. Check cabling and all connections.
4. Disconnect the serial connection and determine if the controller is functioning properly without the display.

**Problem:** The display rate and serial-controlled rate do not match.

**Solution:**

1. Verify the current firmware is running on the display and the Serial Application Rate Module.
2. Check the percent rate change.

## Troubleshooting Serial Control Applications—Granular

**Problem:** Rate changes on the display, but not on the controlled console.

**Solution:**

1. Verify the current firmware is running on the display and Serial Application Rate module.
2. Check the settings specific to your controlled console.
3. Check cabling and all connections.
4. Disconnect the serial connection and determine if the controller is functioning properly without the display.

**Problem:** The display rate and serial-controlled rate do not match.

**Solution:**

1. Verify the current firmware is running on the display and Serial Application Rate Module.

2. Check to make sure the nominal rate in the display matches the nominal rate in the serial-controlled console.

## ISO Serial Application–Support Controllers



**ATTENTION!:** ISO SAR Module is **NOT COMPATIBLE** with Kuhn QUANTRON-E

Brand	Model	Additional Information	Controller Channel	Multiple Product Control	Automatic Swath Control**
Hardi	HC 5500 (with JobCom)	Multiple Section <sup>1</sup>	NA		X
Bogballe	Zurf	Multiple Section <sup>1</sup>	NA		X
	Calibrator ICON	Multiple Section <sup>2</sup>	NA		X
	Calibrator UNIQ	Multiple Section <sup>2</sup>	NA		X
	Calibrator 2003	Multiple Section <sup>2</sup>	NA		X
UNIA Group	BRZEG	Single Section	NA		X
Reco/Sulky	Vision-X	Single section	NA		X
Kuhn	Quantron	Single section	NA		X
LH Agro	LH5000	Single section	NA		X
RDS	Pro	Single section	NA		X
Amazone	Amatron+	Single section	NA		X
Rawson	AccuRate	Single Section or Split Planter <sup>3</sup>	NA		X
	AccuPlant	Single section	NA		X
Veris	Precision Controller	Single section	NA		X

### Version 1.7 or newer.

1 Performs section control by decreasing the overall swath width based on machine and controller setup.

2 Performs section control by reducing the applied rate to match the new “section” width; overall swath width is not physically changed.

3 Dependent on number of motors operated by the controller.

# ISOBUS Serial Communication

\*\*Automatic Swath Control is dependent on the vehicle/implement and controllers capability.

Ensure the vehicle or implement is physically capable of Automatic Swath Control.



**ATTENTION!:** ISO SAR Module is **NOT COMPATIBLE** with Kuhn **QUANTRON-E** Version 1.7 or newer.

Brand	Model	Sprayer	Row Crop Planter	Seed Drill	Spinner Spreader
Hardi	HC 5500	X			
Bogballe	Zurf				X
	Calibrator ICON				X
	Calibrator UNIQ				X
	Calibrator 2003				X
UNIA Group	BRZEG				X
Reco/Sulky	Vision-X	X			X
Kuhn	Quantron	X			X
LH Agro	LH5000	X		X	X
RDS	Pro	X			X
Amazone	Amatron+	X		X	X
Rawson	AccuRate		X		X
	AccuPlant		X		
Veris	Precision Controller		X		

# Table 1 Pin Out

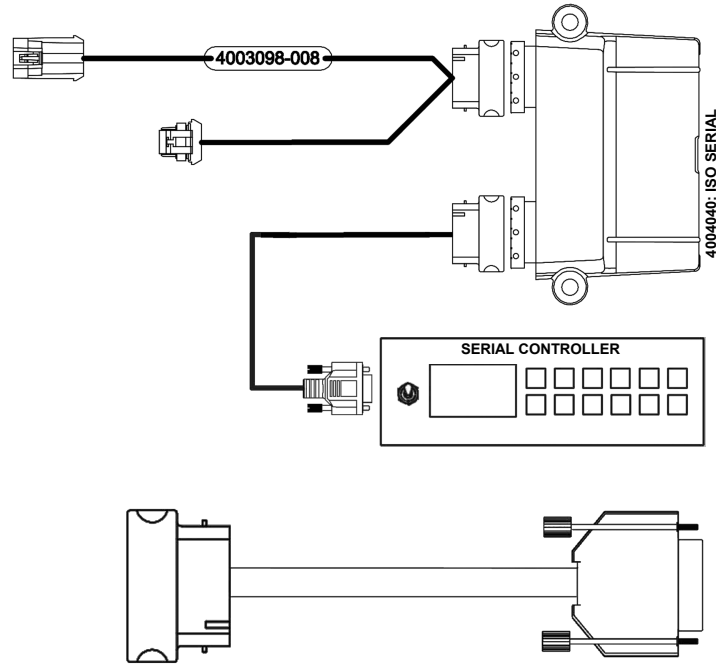

**SERIAL CABLE**

1	6	<b>4004044-6 SERIAL NULL FEMALE</b>
		<b>PIN 2 GREEN MODULE RS232 TX</b>
5	9	<b>PIN 3 WHITE MODULE RS232 RX</b>
		<b>PIN 5 BLACK RS232 GROUND</b>

		<b>4004046-6 ISO NORMAL MALE</b>
		<b>4004044-6 SERIAL NULL FEMALE</b>
5	9	<b>PIN 2 WHITE MODULE RS232 RX</b>
		<b>PIN 3 GREEN MODULE RS232 TX</b>
1	6	<b>PIN 5 BLACK RS232 GROUND</b>
		<b>PIN 7 BLUE MODULE RS232 RTS</b>
		<b>PIN 8 BROWN MODULE RS 232 CTX</b>

## InCommand™-Serial Bridge Module-Amp Vehicle

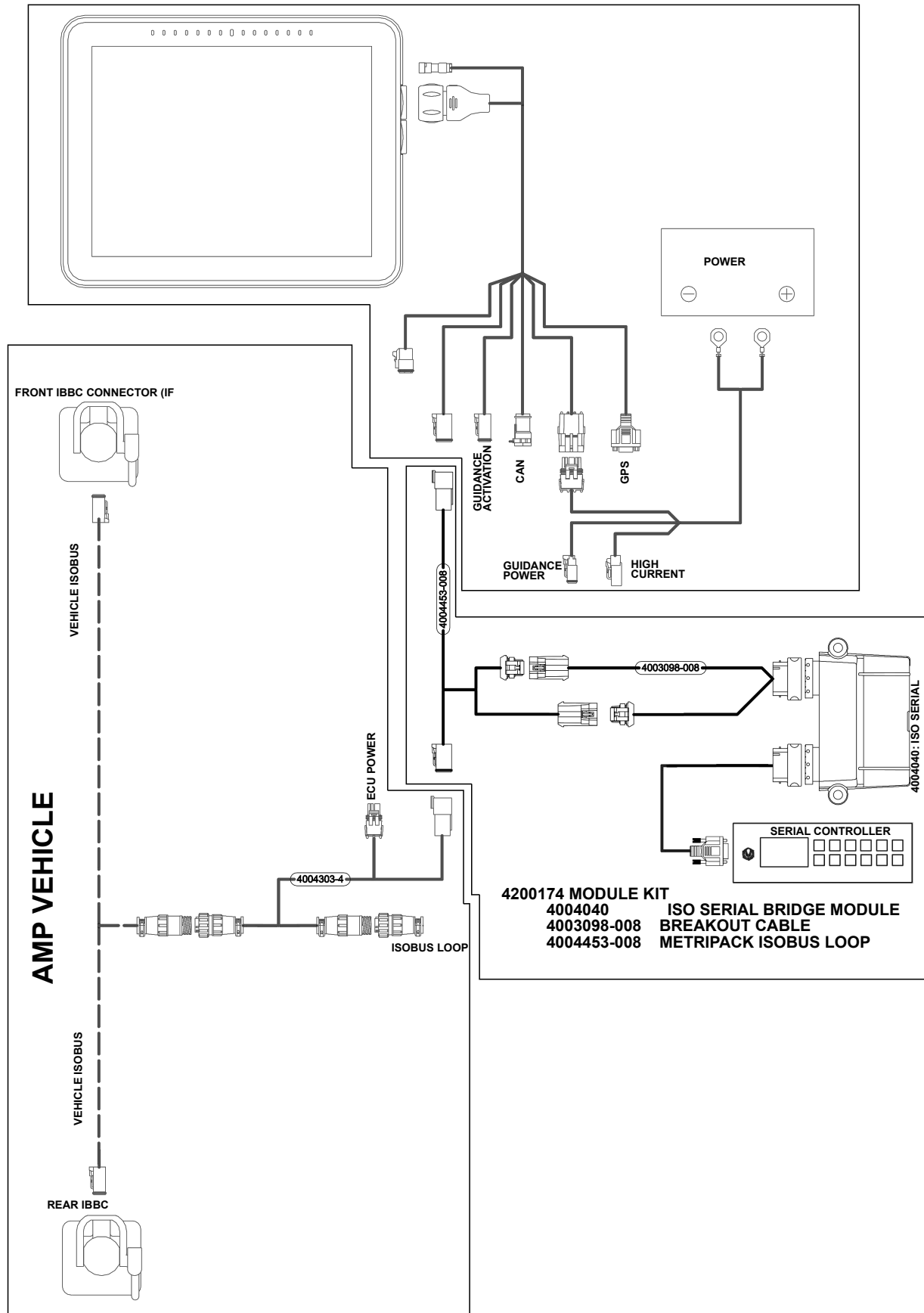

# InCommand-Serial Bridge Module-Deutsch Vehicle

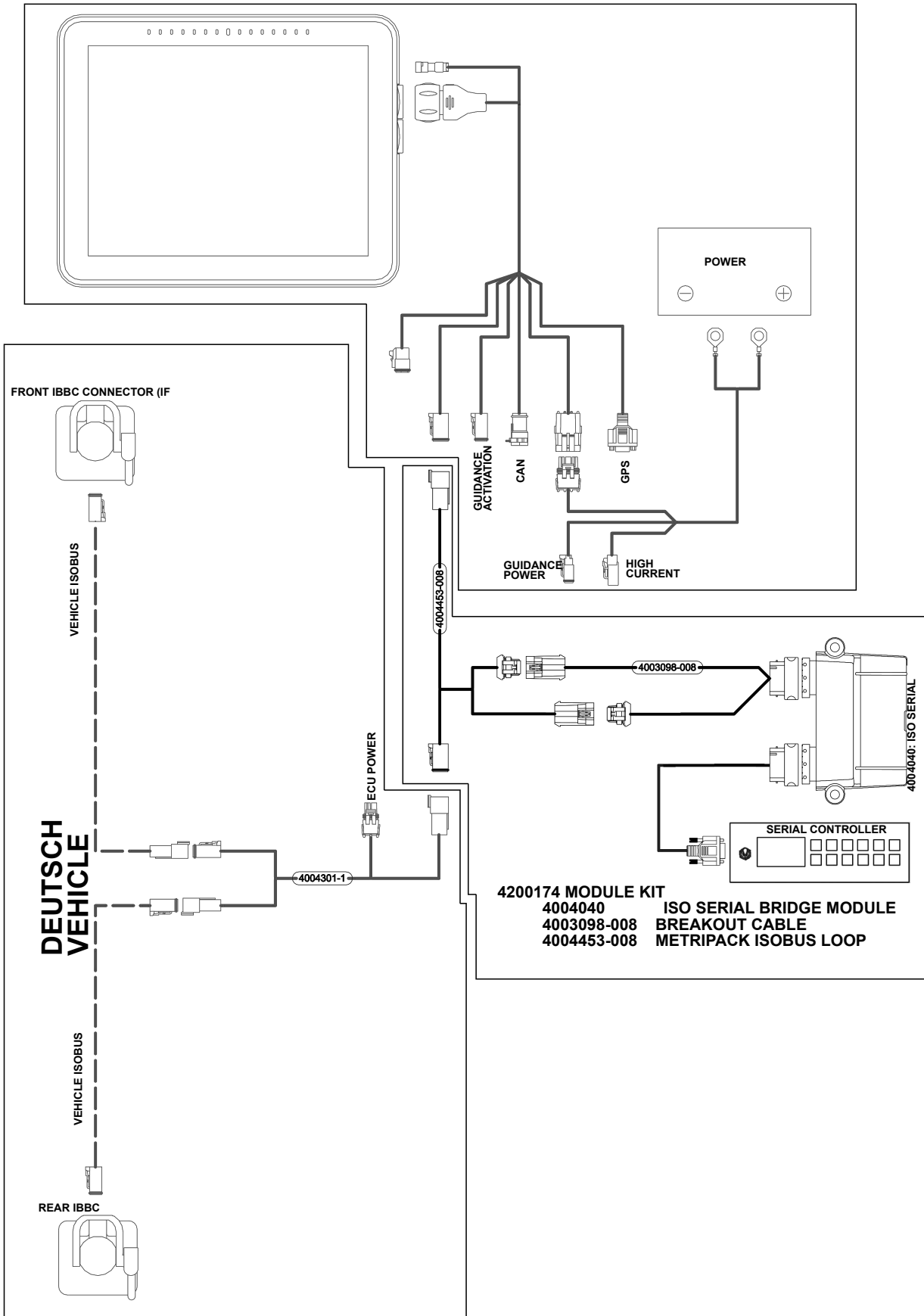



## InCommand-Serial Bridge Module-ISO Retrofit Vehicle

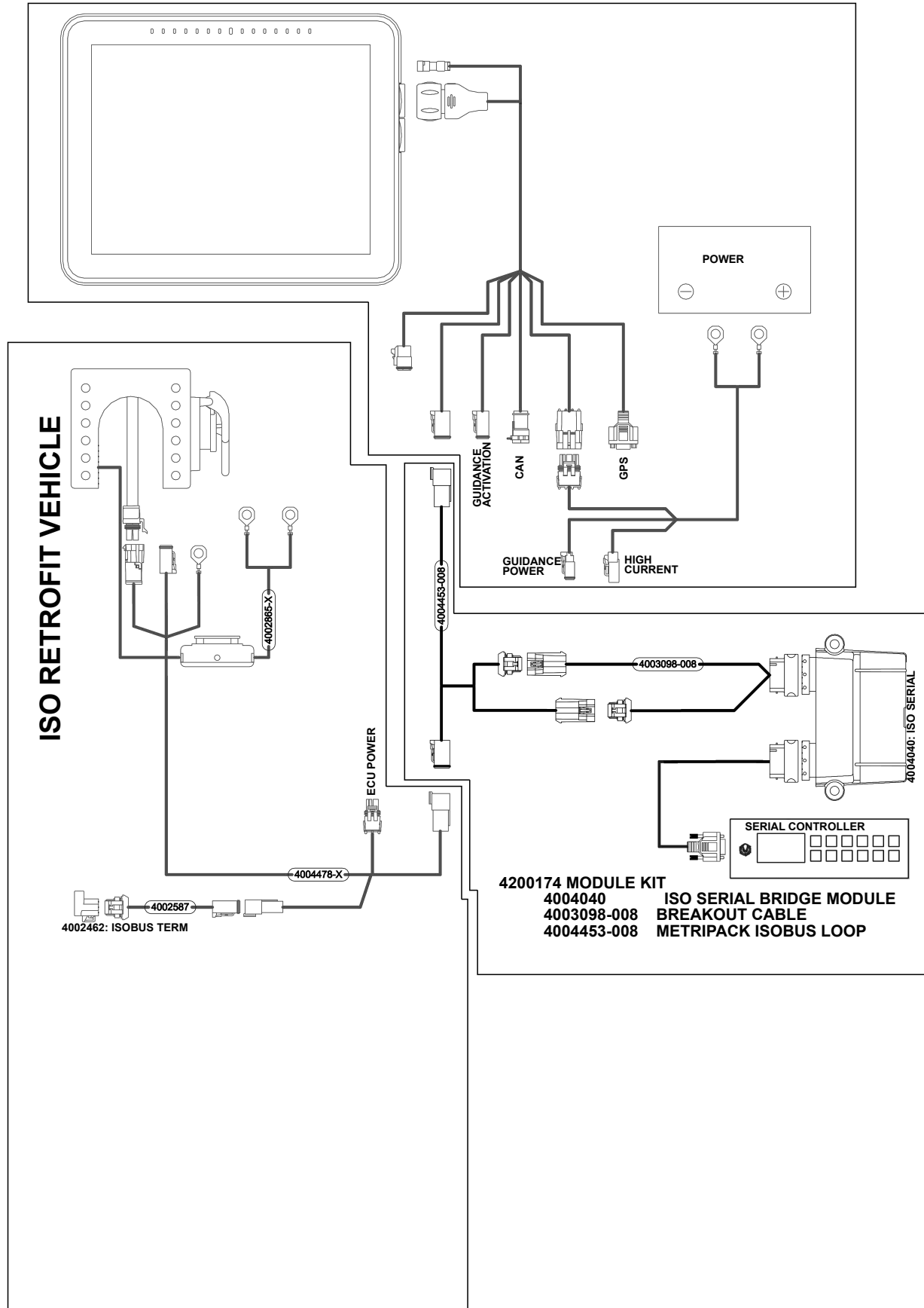

# InCommand-Serial Bridge Module-Non ISOBUS Vehicle

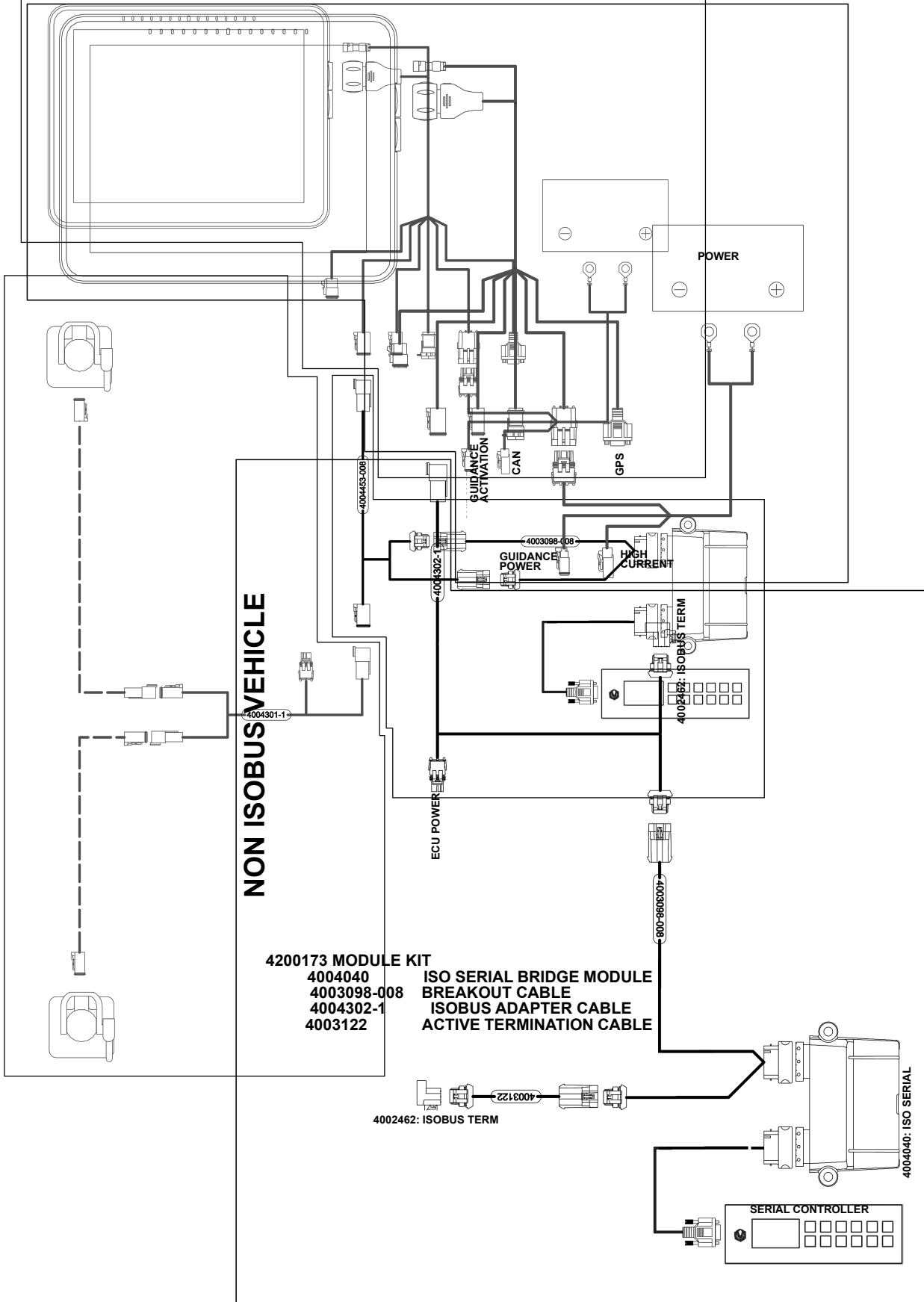





DirectCommand™ interfaces with the Raven SCS Sidekick™ for complete control over chemical injection applications. The display can support up to four Raven SCS Sidekick™ injection pumps plus a liquid carrier.

## Map View

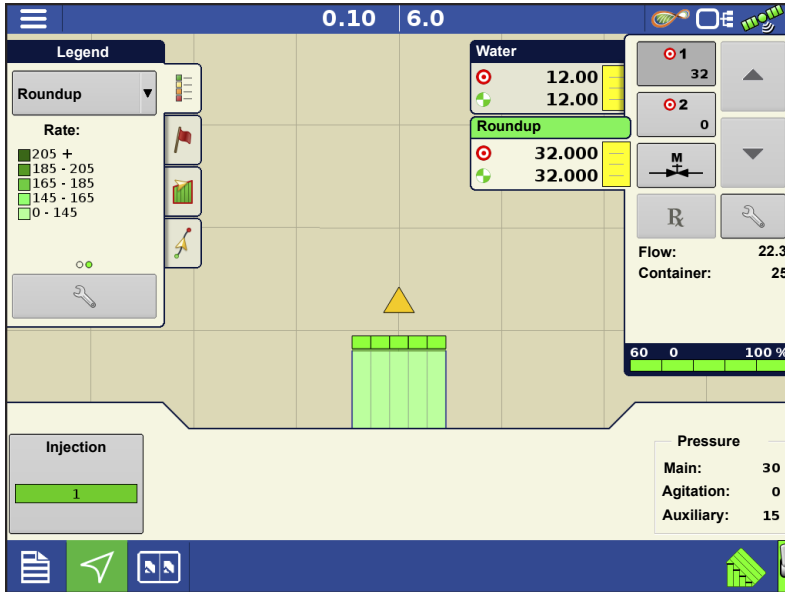

Once a configuration has been completed, the Map View screen appears.

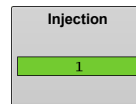

Number of injection controllers in the configuration. Bar turns green when product is being dispensed.

## Create Configuration

A wizard will guide you through the process of selecting or creating a configuration with application settings.

The configuration can be started in two places:



OR

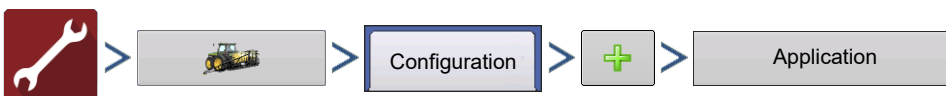

Your Operating Configuration will then be viewable when you start a new Field Operation with the Application Wizard.

You can also use the **Manage Equipment** button to create or edit specific vehicles and implements.

## Load Configuration



Press the Application App from the home screen. This will take you through the steps needed to load a configuration.

## Setup Configuration



OR

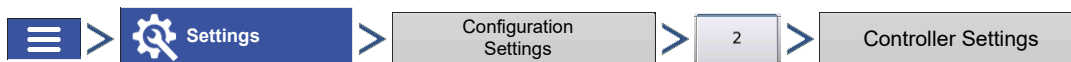

## Pump Calibration

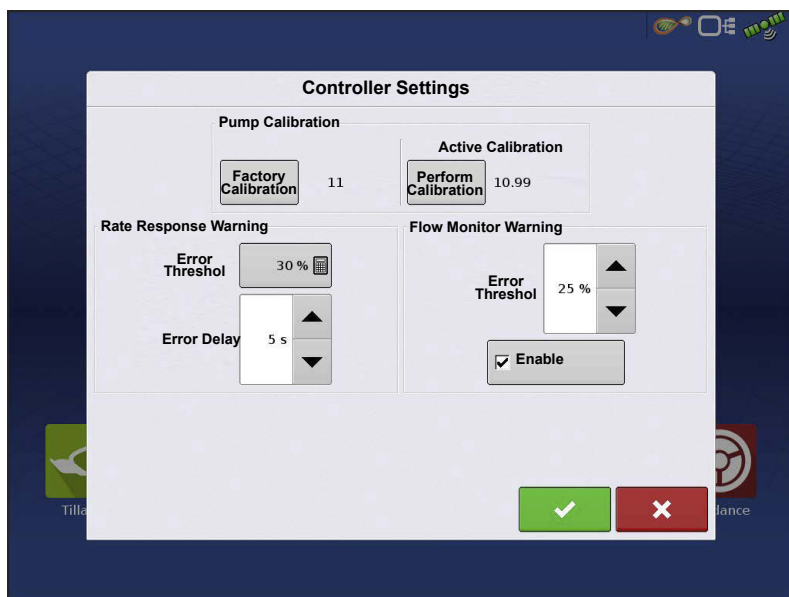

•**Factory Calibration**—This number is found on the tag of the Digital Pump Speed Sensor. This tag number represents pulses per 10 fluid ounces. Divide the tag number by 10 and enter this number. Once entered, this number should not be changed.

•**Perform Calibration**—Press the Perform Calibration button to begin the calibration procedure for the Direct Injection pump. The pump will not run

until this calibration has been performed.

## Rate Response Warning

- **Error Threshold**—The user-defined percentage of actual rate error allowed before an alarm sounds.
- **Error Delay**—The number of seconds that the actual rate falls out of the error threshold before an alarm sounds.

## Flow Monitor Warning

- **Error Threshold**—The percentage of perceived application error, based on the discharge flow sensor.
- **Enable Warning**—The Enable Warning check box allows you the option of displaying the Flow Monitor Warning.

## Calibrating an Injection Pump

Calibrate each injection pump at the beginning of each season and any time repairs are made.



1. **Enter Factory Calibration**—Before entering a Direct Injection Calibration, a Factory Calibration must be entered. If you have not already done so, enter the Factory Calibration Number by pressing the Factory Calibration button. This number is found on the tag of the Digital Pump Speed Sensor. This tag number represents pulses per 10 fluid ounces. Divide the tag number by 10 and enter this number. Once entered, this number should not be changed.
2. **Press Perform Calibration**—Underneath Pump Calibration, press the Perform Calibration button.
3. **Prime the Direct Injection Pump**—The Pump Calibration Wizard appears. Before beginning this calibration procedure, it is recommended that you first prime the Direct Injection pump. Press the Prime button and continue along with the priming procedure as described in [Priming an Injection Pump on page 765](#). After the priming procedure is finished, you will return to this Pump Calibration Wizard window. Press  to continue.

4. **Enter the Dispense Amount**—Enter the amount of product that you want dispensed. Press

 to continue.

5. **Acknowledge the Warning**—Prepare to catch any product dispensed in an appropriate container. Press  to continue.

6. **Start Calibration**—Press the green-colored START button to begin the calibration procedure. The Pump Calibration Wizard automatically counts up to the amount that you specified in Step 4. The button will turn red and displays STOP while the product is being dispensed. When the procedure is finished, the button will display START and turn gray.

Press  to continue.

 **NOTE!:** You may press the Reset button if you wish to start the calibration procedure over.

7. **Enter Actual Dispense Amount**—Enter in the actual amount of the product that was dispensed. Press  to continue.

8. **Calibration Complete**—The Pump Calibration number appears. The New Injection Pump Calibration Number now appears in the Pump Calibration screen. From this point, you may either:

- Repeat the calibration by pressing the **Repeat Calibration** button.
- Press  to complete the calibration and exit the Pump Calibration Wizard.

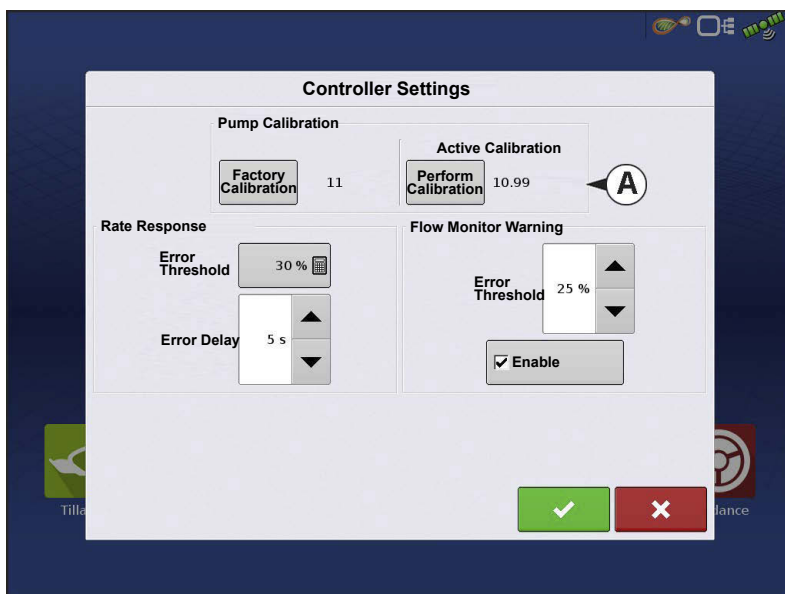

9. **Calibration Displayed on Controller Settings screen**—The new Injection **Pump Calibration Number (A)** now appears in the Pump Calibration screen.



## Priming an Injection Pump



If you are using a Direct Injection configuration, you must prime the Injection Pump each time you flush or refill a tank, or change products. This ensures that air is not in the product lines.



**ATTENTION!:** Failure to perform this priming procedure before beginning a Direct Injection application could result in skips at the

start of field operations.

1. **Press Injection Control button (A)**—To prime the Injection Pump, first go to the Map screen. Press the Injection button. The Injection button is located at the left-hand side of the Equipment Tab. The Injection Controls screen appears.

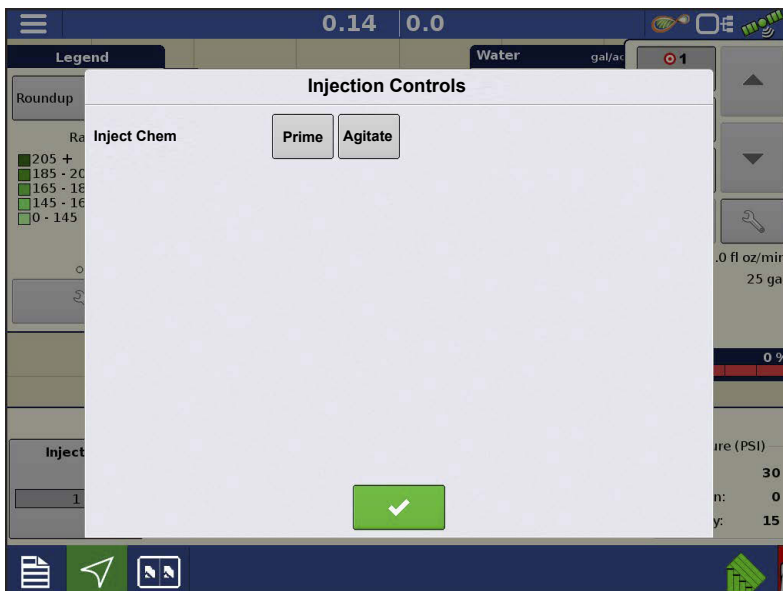

2. **Press the Prime button**—At the Injection Controls screen, press the Prime button.

- You may agitate the Direct Injection tank by pressing the **Agitate** button. Once pressed, this Agitate setting will continue even after the Priming process is finished, until you press



a second time. To determine if a product should be agitated, check the product specifications.



**NOTE!:** In order for a Direct Injection tank to agitate the product, you must set the agitator motor switch on **Run** (which agitates the product continuously) or **Pulse** (which agitates the product intermittently).

3. **Acknowledge the Warning**—A warning appears, stating that you must circulate the product back to the Direct Injection tank. Acknowledge the warning by pressing .

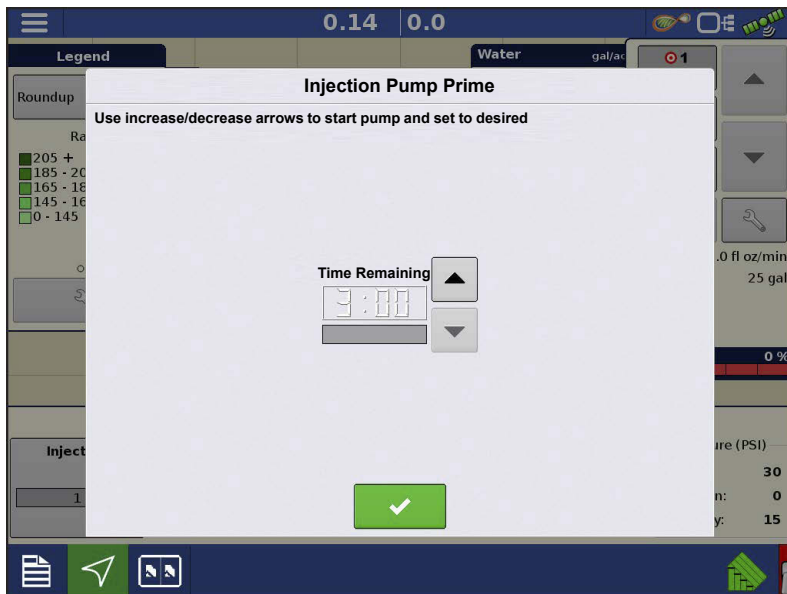

#### 4. **Start Pump and Set Desired Speed**

**Speed**—The Injection Pump Prime screen appears. The countdown time remaining is shown in the black box. The bar underneath turns green when the pump is operating. Use



to manually increase or decrease the pump speed.



**NOTE!:** The recommended priming time is three minutes (3:00),

but the routine can be ended at any time by pressing .

5. **Acknowledge the Warning**—A warning appears, stating that you must return chemical injection plumbing to a field-ready state. Acknowledge the warning by pressing .

## Injection Diagnostics



The Injection Diagnostics screen provides raw values from sensors verifying that the pump's output is working. To go to the Injection Diagnostics screen, press



. At the Devices screen, highlight the item marked **Direct Injection Module** then press the **Diagnostics** button. The Injection Diagnostics screen appears. In addition to the Controller's Name and

Serial Number, it provides the following information:

- **Digital Pump Speed**—Displays volume information, shown in Hz.
- **Analog Pump Speed**—Displays varying voltage as pump speed is increased or decreased.
- **Discharge Flow Monitor**—Displays information showing that flow is being discharged for every piston stroke.
- **Flow/Speed Sensor Ratio**—The ratio that the system derived for calibration.

## Troubleshooting

When controlling a chemical injection pump using the Injection Module PN: 4000896, the configuration requires the use of a Liquid Module PN: 4000394. The injection control is based off of the vehicle that has been configured for the liquid DirectCommand control channel. Once configured, the Injection pump uses the same switch inputs and ground speed input that has been configured for the liquid system.

## Direct Injection: Pump Doesn't Run

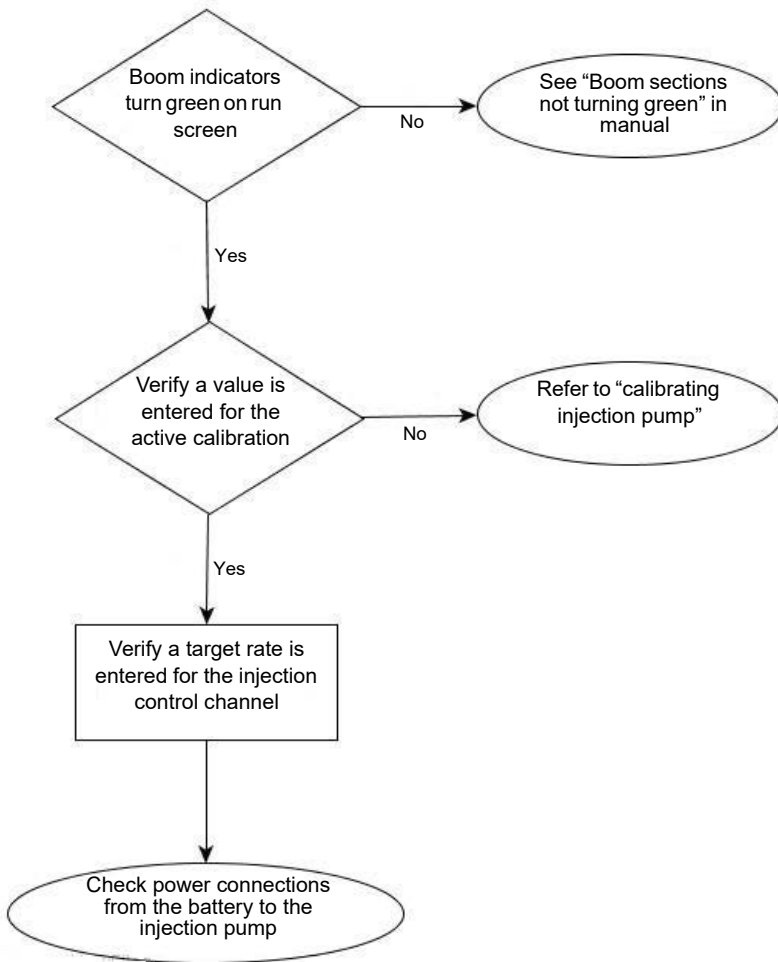

Power can be checked at multiple locations. First is the connection at the Injection module where the battery power cable plugs in. The second location is the output connection found on the injection module. The third is found at the 2 pin weather-pack tower found on the injection cable PN: 4000851-3. See table below.

## BATTERY POWER PIN OUTS

	2 Pin Deutsch Plug	2 Pin Deutsch Receptacle	2 Pin WP Tower
Power 12V	1	1	A
Ground	2	2	B

## Direct Injection: Pump Runs Full Speed

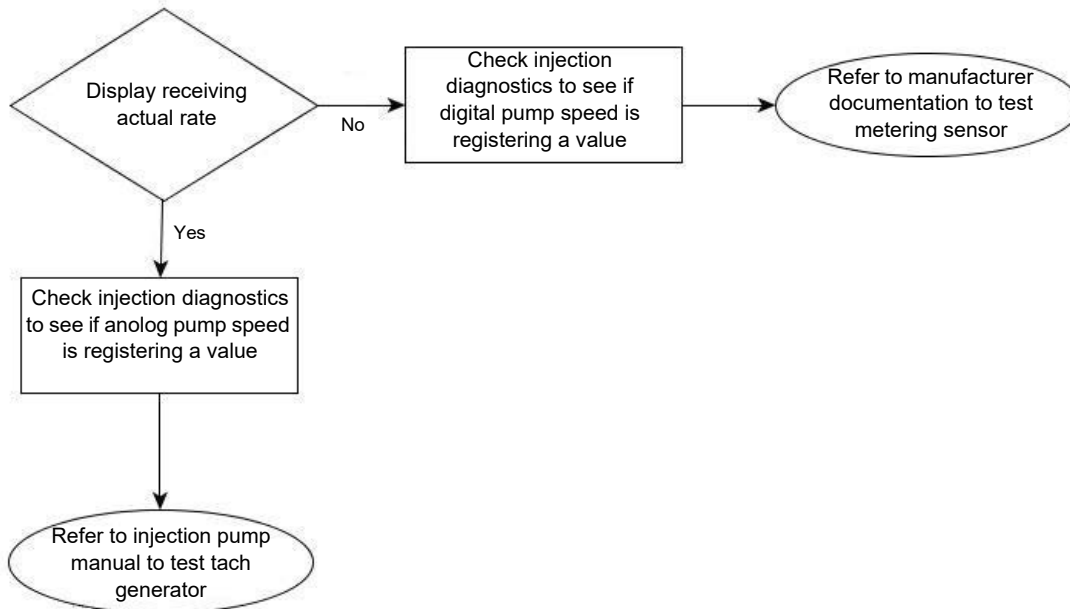

**Digital Pump Speed Sensor** - The injection pump's digital pump speed sensor is used to provide actual rate feedback to the display. If the display is not receiving an actual rate the pump will run full speed and provide a "Rate Not Responding" warning message. See Digital Pump Speed Pin out table below for pin locations. With the section valves On, the cabling can be tested by pulsing the signal and ground pins to verify the total applied increases. It is always best to pulse the pins at least 10 times to make sure the total applied will increase by a noticeable amount.

---

## Digital Pump Speed Pin Outs

	Module Auxiliary Connection 12-Pin Socket	3-Pin Conxall
Power (5V)	12	2
Signal (5V)	3	3
Ground	6	1

## Analog Pump Speed Sensor

The injection pump's analog speed sensor is used in conjunction with the digital pump speed sensor to provide accurate rate feedback. The sensor is a generator that produces a varying voltage dependent on the speed of the pump (9V at max pump speed). The injection module will only get feedback from this sensor when the pump is rotating. If the analog sensor is not providing a feedback to the module, the pump will run full speed and will not change speeds manually.

## Analog Speed Pin Outs

	Module Auxiliary Connection 12-Pin Socket	2-Pin WP Shroud
Signal	4	A
Ground	5	B

## Direct Injection: Application Error

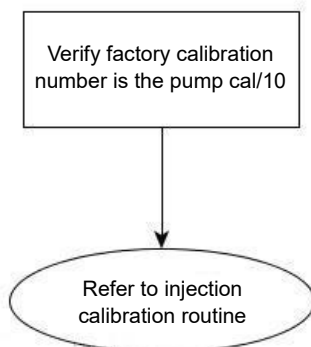

The injection module requires that a pump calibration be performed before actual application can occur. The calibration number found on the tag of the injection pump's digital speed sensor needs to be divided by a factor of 10 before entering it as the factory calibration number. If the factory cal number is entered wrong, the pump calibration routine will not finish due to a high application error.

 **NOTE!:**

- The pump calibration will fail if error is >10% from the factory calibration number.
- If the calibration fails, check pump and plumbing for physical damage or excess wear.

## Direct Injection: Discharge Flow Sensor Error

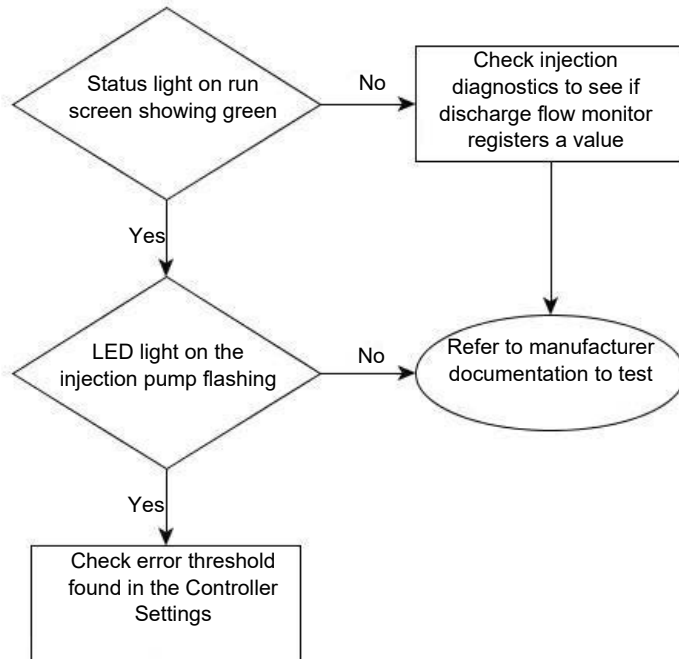

The discharge flow sensor is used as a system check to see if product is actually exiting the output of the pump. The sensor is a shuttle valve that allows feedback for every stroke of the pump. If Flow Monitor Warning is enabled, the display will provide a message if the discharge flow sensor falls out of its calibrated value. See table below for pin locations.

## Discharge Flow Sensor Pin Outs

	<b>Module Auxiliary Connection 12-Pin Socket</b>	<b>3-Pin WP Shroud</b>
Power (12V)	11	A
Signal	9	B
Ground	8	C

---

## Direct Injection: Inlet Restriction

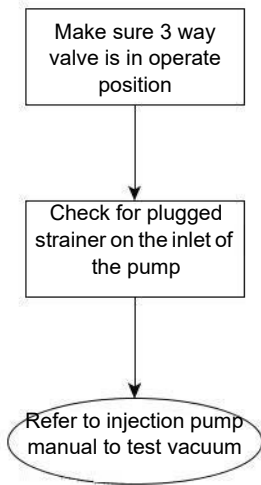

The injection pump has a vacuum switch that is used to warn operators of any restriction at the inlet of the pump. The sensor is a normally closed switch that opens if a restriction is encountered in the injection system. A warning will be displayed for the operator if the vacuum switch opens due to restriction. See table below for pin locations. The operator can test the system by unplugging the sensor, which will trigger the warning. If the operator jumps pins A and C, the warning will end.

### Vacuum Switch Pin Outs

	<b>Module Auxiliary Connection 12-Pin Socket</b>	<b>3-Pin WP Shroud</b>
Power (12V)	2	C
Signal	10	A



## OptRx®

OptRx uses sensors, usually mounted on the sprayer's booms, to assess reflected light to determine plant vigor. It assigns numeric values to the varying levels of vigor to create a Vegetative Index (VI). Using the VI, OptRx calculates nitrogen application rates, to apply a variable rate on the go. OptRx creates nitrogen rates either by using the N Algorithm or by using the user defined Application Rate Table. OptRx can also be used for scanning purposes.



**ATTENTION!:** Proper care of sensor will ensure accuracy and dependability.

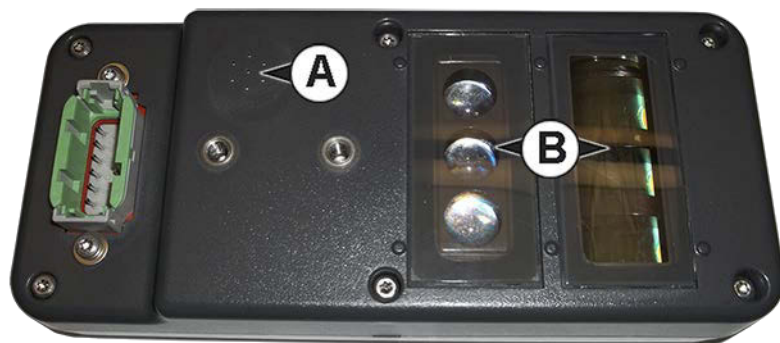

Sensor is designed with a vent (A) to prevent moisture from accumulating and damaging the electronics. Use care when attaching/using/storing sensor, so that nothing blocks the vent.

Ensure that the optics (B) are not exposed to direct water and sunlight for extended periods of time. Because direct sun (UV light) can be destructive, sensor should be oriented so that optics face the ground (even when not in use). To maximize the life and performance of sensors, they should be removed from equipment and housed in a protective environment when not in use.

## Load Configuration



Press the Application App from the home screen. This will take you through the steps needed to load a configuration.

Once a configuration has been completed, the Map View screen appears.

## Map View

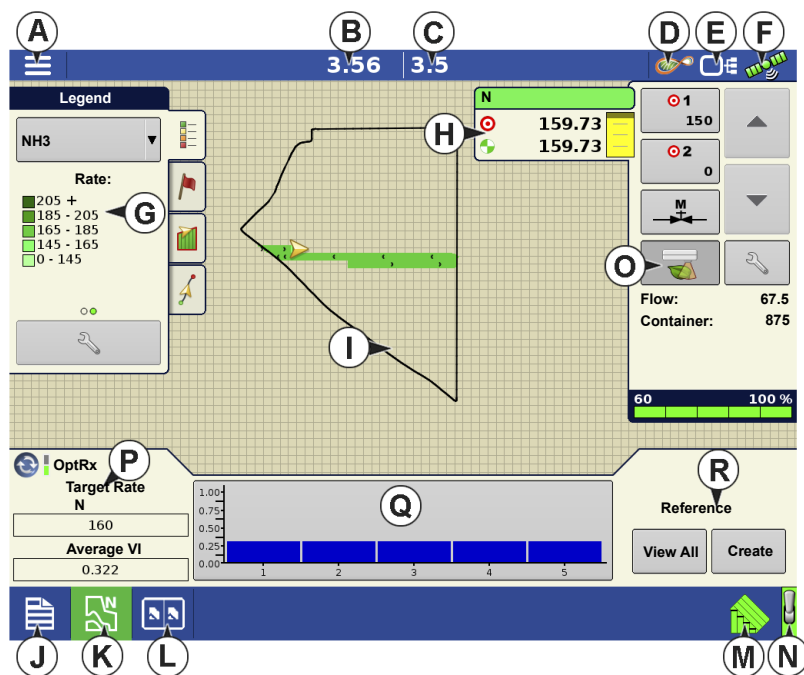

- A. Menu button
- B. Total Logged Field Area
- C. Ground Speed
- D. AgFiniti® Status
- E. Diagnostics
- F. GPS Signal Indicator
- G. Display Legend
- H. Product Control toolbox
- I. Vehicle Icon
- J. Event Summary
- K. Map View

L. Split screen

M. AutoSwath™

N. Master Switch Status

O. OptRx button

P. Target Rate/Average VI

Q. Bar Graph

R. Reference Strip buttons

**i** **NOTE!:** Pressing the Map View button will cycle between the available Map Screen views, and the appearance of the Map View button changes.

## Product Control Toolbox

During DirectCommand™ Run Time operations, the Product Tabs are shown in the upper right-hand side of the Map screen. Press the Product Tabs, and an extended view shows the Rate buttons, Manual Valve Control button, Prescription button, Rate Increase and Rate Decrease arrows, and the Rate Setup button, all of which are described below.

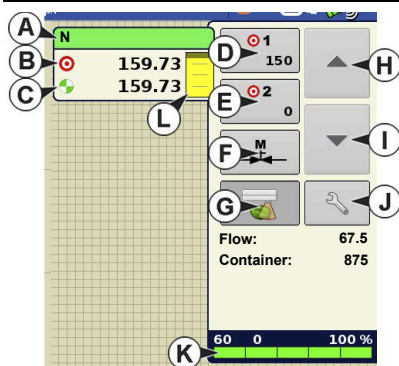

- A. Product
- B. Target Rate
- C. Actual Rate
- D. Rate 1 button
- E. Rate 2 button
- F. Manual Valve Control

G. OptRx button

H. Rate Increase arrow

I. Rate Decrease arrow

J. Rate Setup button

K. Section Status Indicator

L. Container Level

## Product Control Toolbox

**Target Rate**—The Target Rate is desired application rate.



**NOTE!** In some conditions, the Target Rate may increment more quickly than the Actual Rate.

**Actual Rate**—The Flow Sensor returns the actual rate being applied.



**NOTE!** In some conditions, the Actual Rate may increment slower than the Target Rate, or its numeric values may vary before matching the Target Rate.

**Container Level**—The Container Level shows the amount of product in the container.

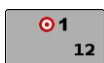



**Rate 1 and Rate 2 buttons**—The Rate 1 and Rate 2 settings represent preset application rates that allow operators to quickly change between desired target rates for each individual product.



**Manual Valve Control button** — The Manual Valve Control button allows operators to specify the position of the control valve. Operators use this option to prime the system before application or clean out the equipment at the end of the day.

---

**Rate Increase and Decrease Arrows** —  /  allow Product Application Rate to be changed according to the Target Rate Increment. In using manual valve control, the increase and decrease buttons allow the position of the control valve to be defined by the operator.

**Prescription button**— 

**Rate Setup button**— 

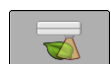

Press the OptRx prescription button to engage the OptRx system to apply variable rate N, based on data received from the sensors. The OptRx button will not be selectable until a Reference Strip is made or Application Rate Table is in use.

### Create Configuration

A wizard will guide you through the process of selecting or creating a configuration with application settings.

The configuration can be started in two places:



OR

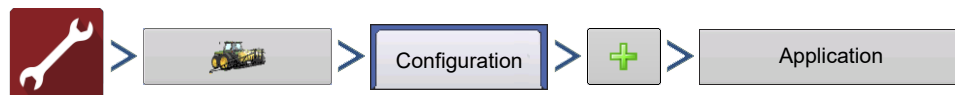

Your Operating Configuration will then be viewable when you start a new Field Operation with the Application Wizard.

You can also use the **Manage Equipment** button to create or edit specific vehicles and implements.

### Application Rate Table

To use the Application Rate Table, you need to activate it by check marking the "Use Application Rate Table" box in the Crop Sensor setup. It can be accessed one of two ways:



OR



## Crop Sensor Rate Table

Lower Bound	Upper Bound	Rate
0.000	0.125	32.0
0.126	0.250	28.0
0.251	0.375	24.0
0.376	0.500	20.0
0.501	0.625	16.0
0.626	0.750	12.0
0.751	0.875	8.0
0.876	1.000	4.0

The Application Rate Table allows a user to define their desired rates to apply any product to any crop type, based on the vegetative index. You can create up to 16 ranges and assign a desired rate to these ranges. You also have the ability to select your VI type to NDRE or NDVI. (For more information about NDRE and NDVI, refer to the Glossary.) If you select to use the Application Rate Table you will

not make a reference strip. You will set up the rate table and start applying. If you don't select to use the Application Rate Table you will have to make a reference strip before you apply. The exact values for these settings are up to the grower, ideally after consulting with an agronomist. Ag Leader Technology does not provide agronomic advice.



**NOTE!:** When utilizing the Application Rate Table, a minimum of two sensors are required in order to actively apply product.

## N Algorithm Setup

OptRx has a very powerful N Algorithm to calculate the optimal rate of nitrogen to apply to the crop. A product containing nitrogen must be selected for the N Algorithm to become active. In

order for the OptRx Crop Sensor Module to use the N Algorithm to recommend an N rate, you must scan a portion of the field to create a V.I. Reference Value.

## Create an OptRx V.I. Reference Value

In order for the OptRx Crop Sensor Module to use the N Algorithm to recommend an N rate, you must scan a portion of the field to create a V.I. Reference Value.

This V.I. Reference Value is a baseline that the system uses to evaluate the rest of the field.

When creating a reference strip you need to select one of the four Sensor Rx's:

**Corn**—Scan the most vigorous portion of your field for 300 seconds (5 minutes).

**Wheat North America(Post-Tillering)**—Scan the most vigorous portion of your field for 300 seconds (5 minutes).

**Wheat North America(Tillering)**—Scan the most vigorous portion of your field for 300 seconds (5 minutes).

**Europe**—Scan the portion of your field where the plants show an average amount of vigor and growth. Scan this area for 150 seconds (2.5 minutes).



**NOTE!** In order to create a reference strip, a minimum of two sensors is required.

### Scan a Reference Strip

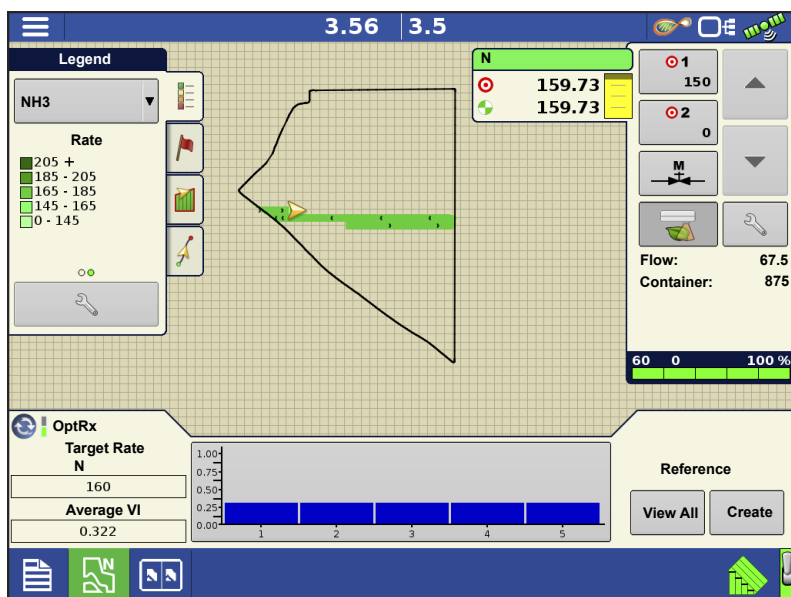

This section describes how to scan a reference strip into the display. This reference strip determines the V.I. Reference Value. It assumes that you have already performed the following tasks:

- Chosen the appropriate part of your field to create a reference strip.
- Created an OptRx module configuration.

- Created a Field Operation Configuration.

1. **Press Create Button**—Press the  , located on the bottom right-hand side of the Map screen's Equipment Tab.

If a reference strip has already been created, a warning appears, notifying you that this will unload the current reference strip. Press  to continue.

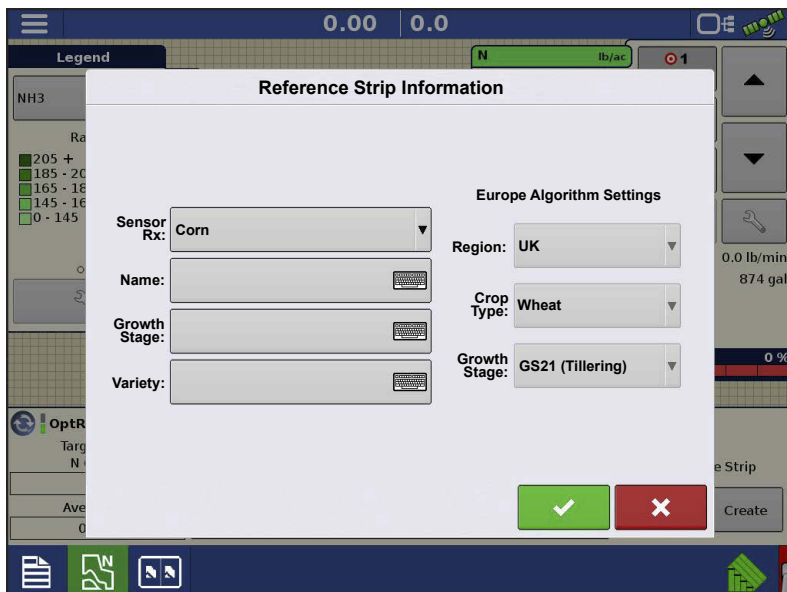

## 2. Enter Reference Strip

**Information**—The Reference Strip Information screen appears.

Select the correct **Sensor Rx**. Press



to enter the Name, Growth Stage, and Variety. For Europe Algorithm Settings view below.



**NOTE!** For Corn, a growth stage of V5 or later is needed for accurate application.

When selecting Europe as Sensor Rx, the **Europe Algorithm Settings** become active. A region, a crop type and a Growth Stage need to be selected.

If your region is not noted in the drop-down menu, select the **Region** that reflects your current position best when comparing geographic location, climate, general soil types and farming practices. The region setting is used for fine-tuning and optimizing the N Algorithm.

Select the **Crop Type** on which you are applying fertilizer. For the crops Wheat, Barley and Rapeseed the N Algorithm is verified by independent field experiments.

Select the **Growth Stage** that reflects your current crop status. For Wheat and Barley the Growth Stage is used to select the most appropriate VI index, NDVI or NDRE, further it will be used for fine-tuning and optimizing the N-Algorithm.

Press  when finished.

3. **Drive Reference Strip**—A screen appears, stating that you should drive the applicator to the start of the reference strip. When ready, press  and drive the reference strip.

4. **Recording Reference Strip**—When you are driving the Reference Strip,  appears in the Equipment Tab. This bar counts the number of seconds that you record the reference strip.

For best results when driving the Reference Strip, it may be beneficial to Pause the Reference Strip when driving over parts of the field that are in a lower than average condition, such as the headlands.

After the minimum required time elapses to create a Reference Strip, the “Cancel” button will change into .

5. **File Name**—Press the Stop button when you wish to finish creating the Reference Strip. A dialog appears indicating the Reference Strip is saved. Press  to accept.

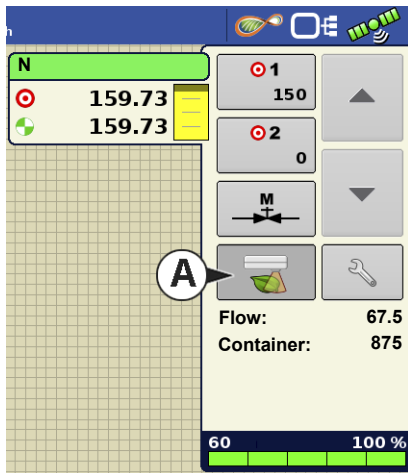

6. **OptRx Sensors Apply Variable Rate**—The OptRx sensors will apply variable rate N, based on data received from the sensors and the current N Algorithm settings. N Algorithm settings must be reviewed for each application to verify correct inputs are used.

 appears in the Product Control Toolbox. (A)

7. (OPTIONAL) **View Reference Strip**





If desired, you may review this reference strip by pressing the **View All** button, located on the bottom right-hand side of the Map screen's Equipment Tab. The file name of the new reference strip appears in the Reference Strip Selection screen. To delete a reference strip, highlight the file name and press .

## Crop Sensor Settings

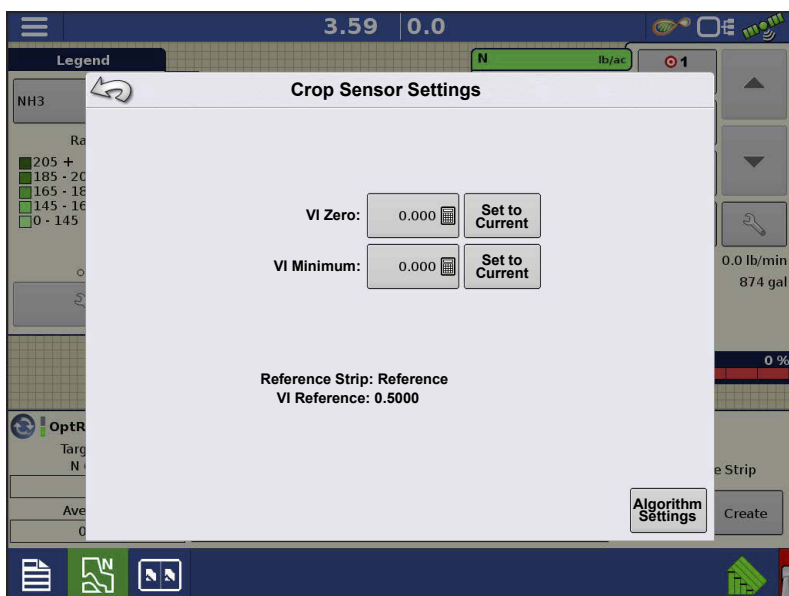



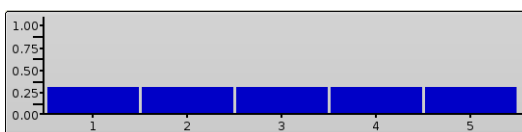

The Crop Sensor Settings screen is where you can adjust application rate settings specified by the OptRx Crop Sensor module. The VI Zero and VI Minimum settings are used as a buffer to prevent applying the wrong amount of N or applying it in areas where doing so would be ineffective. To access the Settings screen, press the OptRx Crop Sensor button,



located in the box containing the Map screen's VI Bar Graph.

---

**VI Zero** — The threshold below which the Crop Sensor applies a zero rate. This setting is used to prevent applying N over bare ground or permanently damaged crops. You may enter in a value either by pressing , or you may enter in the current VI value by pressing .

**VI Minimum** — The threshold below which the Crop Sensor applies the minimum rate. This setting is used to apply a minimum amount of N on ground with damaged crops. You may enter in a value either by pressing , or you may enter in the current VI value by pressing .

The minimum rate may be adjusted at the Crop Sensor screen, which is accessed by pressing the **Algorithm Settings** button.

**Reference Strip** — The name of the Reference Strip that you entered during the scanning procedure.

**VI Reference** — Value of a healthy crop biomass used in reference for calculating the proper N application rate

**Algorithm Settings** — Press this button to access the Sensor Setup screen, where you can adjust the inputs used by the N Algorithm to calculate to optimal Nitrogen rate. Without a valid Reference Strip this button will not be active. Please refer to the Crop Sensor Setup section below for information on how to decide on what inputs to use for the N Algorithm.

## Crop Sensor Setup

The Crop Sensor Setup screen is where you can adjust how OptRx calculates the nitrogen rate to apply. Here you can also select the usage of the Application Rate Table. You can access the Sensor Setup screen by:

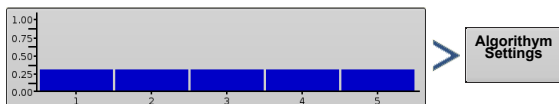

OR

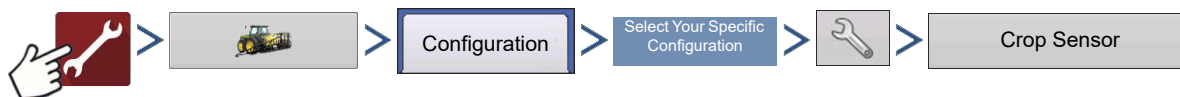

OR



**NOTE!:** You must have a Reference Strip loaded for the Algorithm Settings button to be active.

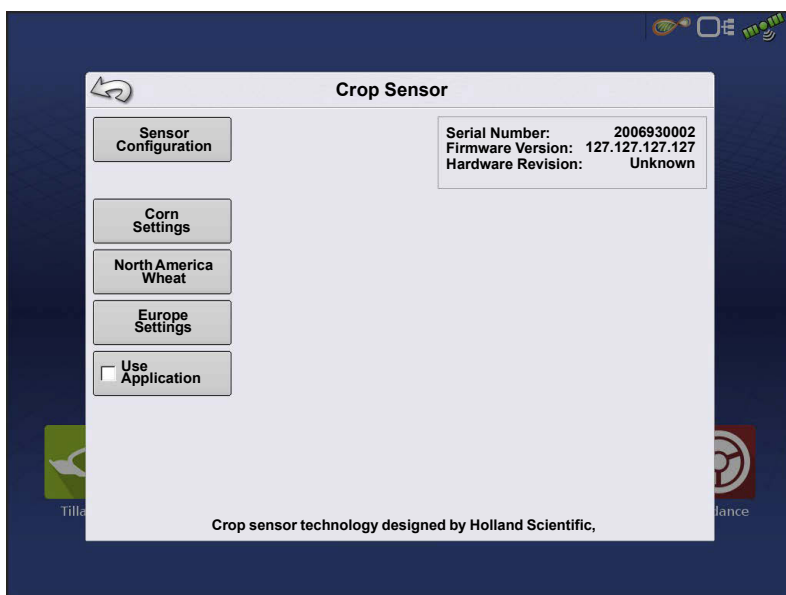

---

## Algorithm Setup

Depending on the Sensor Rx that was selected when making the Reference Strip you will use one of the three Algorithm Setup menus:

- Corn Settings
- North American Wheat Settings
- Europe Settings

All units represent pounds (kilograms) of nitrogen.

### Corn Settings

Corn Settings

**Minimum Rate**—This input should be reviewed and set for each application.

Algorithm implication: The Minimum Rate is the amount of nitrogen the operator wants applied to the healthiest areas of a field. Keep in mind, OptRx may apply very low amounts or zero N if crop appears healthy at the time of application, however the N reserves in the soil may not be adequate to achieve target yield. This ensures some amount of N is applied in these healthy areas.

**Maximum Rate**—This input should be reviewed and set for each application.

Algorithm implication: This is the maximum amount of nitrogen the operator wants applied to the poor areas of a field. Keep in mind, OptRx may recommend a high rate if crop appears very unhealthy at the time of application, however the crop may not benefit from extremely high rates of nitrogen.

**Rate Increment**—This input is dependent on your controller and N-product; it can vary per application.

Algorithm implication: The Rate Increment will define the step size for the variable rate prescribed by the N Algorithm. The system will not change the application rate unless OptRx prescribes a new target that is greater than the Rate Increment. If your system is frequently changing target rates and the flow controller has a hard time responding appropriately, increase this setting.

**Economic Optimal Rate**—This input is dependent on the crop per field.

Algorithm implication: The Economic Optimal Rate reflects the estimated total amount of nitrogen uptake by the plant over the growing season. To calculate this, the operator should use a reasonable estimated yield after evaluating current crop conditions and the growing season leading up to application. Once that target yield is determined,

multiply it by the nitrogen use efficiency (NUE) for your particular region and management practice. For this system, NUE is defined as the pounds of nitrogen needed to produce one bushel of corn. NUE can typically range from 0.85 to 1.2\*.

**N Credits**—This input should be reviewed and set for each application.

Algorithm implication: The N Credits is the estimated amount of nitrogen that is available to the plant in the soil from previous year's crop.

**Pre-Sidedress Rate**—This input should be reviewed and set for each application.

Algorithm implication: The Pre-Sidedress Rate is the amount of nitrogen that has been applied for the current year's crop before side-dressing. Keep in mind, not all pre-sidedress nitrogen may be available to the crop due to environmental factors. You may need to adjust this input accordingly\*\*.

\* NUE can vary based on climate, soil organic matter range, form of N applied, timing of N applied, number of N applications, previous crop residue, etc. It is recommended to consult an agronomist if you are uncertain what the NUE should be for the current year's crop.

\*\* Consider the weather and the form of N that was applied prior to your side-dress application. Out of the "X" lbs/acre of N that was applied earlier in the season, enter how much is believed to be available for that crop at the time of application. Talk to an agronomist or an adviser if there are questions about how to estimate this value for your fields.



**NOTE!** The exact values for these inputs are up to the grower, ideally after consulting with an agronomist. Ag Leader Technology does not provide agronomic advice.

## North American Wheat Settings

North American  
Wheat Settings

**Minimum Rate**—This input should be reviewed and set for each application.

Algorithm implication: The Minimum Rate is the amount of nitrogen the operator wants applied to the healthiest areas of a field. Keep in mind, OptRx may apply very low amounts or zero N if crop appears healthy at the time of application, however the N reserves in the soil may not be adequate to achieve target yield. This ensures some amount of N is applied in these healthy areas.

**Maximum Rate**—This input should be reviewed and set for each application.

Algorithm implication: This is the maximum amount of nitrogen the operator wants applied to the poor areas of a field. Keep in mind, OptRx may recommend a high rate if crop appears very unhealthy at the time of application, however the crop may not benefit from extremely high rates of nitrogen.

**Rate Increment**—This input is dependent on your controller and N-product; it can vary per application.

---

Algorithm implication: The Rate Increment will define the step size for the variable rate prescribed by the N Algorithm. The system will not change the application rate unless OptRx prescribes a new target that is greater than the Rate Increment. If your system is frequently changing target rates and the flow controller has a hard time responding appropriately, increase this setting.

**Economic Optimal Rate**—This input is dependent on the crop per field.

Algorithm implication: Economic Optimum N Rate (ENOR) as prescribed by regional agronomists or universities. This value will equal the total amount of nitrogen that is recommended for the crop over its entire life cycle. This will be a user defined value.

**N Credits**—This input should be reviewed and set for each application.

Algorithm implication: The amount of N credits from previous year's crops or manure applications. This will be a user defined value.

**Pre-Topdress Fertilizer**—This input should be reviewed and set for each application.

Algorithm implication: The amount of fertilizer that has already been applied. This includes pre-plant fertilizer, planting fertilizer and post-planting fertilizer that has been applied before topdressing. This will be a user defined value.



**NOTE!** The exact values for these inputs are up to the grower, ideally after consulting with an agronomist. Ag Leader Technology does not provide agronomic advice.

## Europe Settings

Europe Settings

**Planned Rate**—This input should be reviewed and set for each application.

Algorithm implication: The planned rate will be the average rate that the OptRx N-algorithm will prescribe, considering that the reference strip reflects the field average and that the Minimum and Maximum Rate have an equal offset from the Planned Rate. The Planned Rate should be set to the intended flat rate to apply if the OptRx N-Algorithm was not used.

**Minimum Rate**—This input should be reviewed and set for each application.

Algorithm implication: For the Planned Rate to reflect the average OptRx rate prescription, the difference between the Minimum Rate and Planned Rate should be the same as the difference between the Maximum Rate and Planned Rate. The Minimum Rate is the lowest amount of nitrogen operator wants applied. If OptRx prescribes a lower rate system will default to the Minimum Rate.

**Maximum Rate**—This input should be reviewed and set for each application.

---

Algorithm implication: For the Planned Rate to reflect the average OptRx rate prescription, the difference between the Maximum Rate and Planned Rate should be the same as the difference between the Minimum Rate and Planned Rate. The Maximum Rate should be set to the highest amount of nitrogen operator wants applied. If OptRx prescribes a higher rate system will default to the Maximum Rate.

**Rate Increment**—This input is dependent on your controller and N-product; it can vary per application.

Algorithm implication: The Rate Increment will define the step size for the variable rate prescribed by the N Algorithm. The system will not change the application rate unless OptRx prescribes a new target that is greater than the Rate Increment. If your system is frequently changing target rates and the flow controller has a hard time responding appropriately, increase this setting.

**Managed Rate**—This input is dependent on the crop; it should not be changed during the season.

Algorithm implication: The Managed Rate reflects the total amount of nitrogen the crop will uptake throughout a single season. A higher Managed Rate will increase the algorithms aggressiveness, the target rate will show more variation.

**Number of Applications**—This input is dependent on your season planning; it should not be changed during the season.

Algorithm implication: The Number of Applications reflects the total amount on N-applications throughout a season, including pre-seeding applications. A higher Number of Applications will decrease the algorithms aggressiveness, and the target rate will show less variation.

**Application Trend**—This input should be reviewed and set for each application.

Algorithm implication: The Application Trend setting decides whether good crops get a higher N rate, or if poor crops get a higher N rate. The Increase setting trends the N application rate towards the healthier crops. This could result in witnessing greater plant variance within a field. The Decrease setting trends the N application rate towards the unhealthy crops. This could result in witnessing little plant variance within a field.



**NOTE!:** The exact values for these inputs are up to the grower, ideally after consulting with an agronomist. Ag Leader Technology does not provide agronomic advice.

### Override Serial Logging

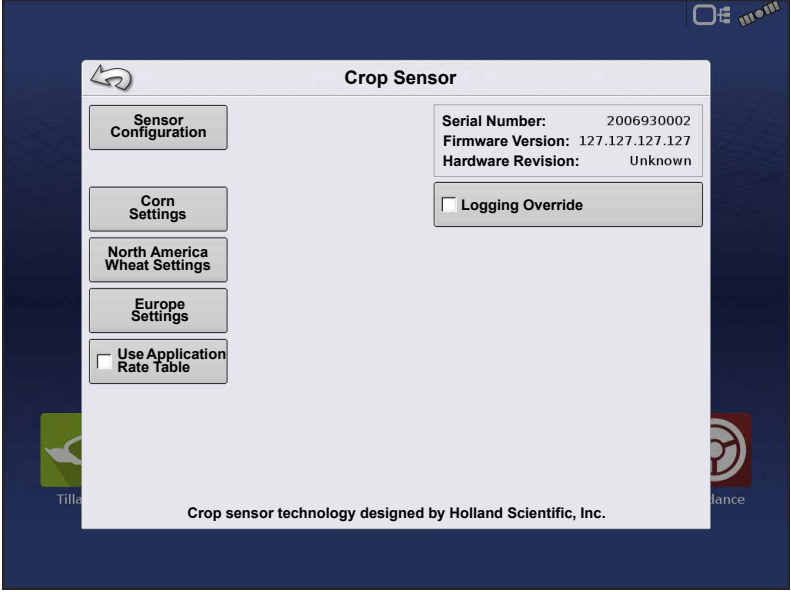

Checking Logging Override will allow OptRx to disable logging based on speed if a reference strip is loaded or an application rate table is being used. This checkbox will only be available when OptRx is configured with a non-Ag Leader product controller (Generic ISOBUS or Serial controller).



**NOTE!:** If left unchecked in these types of configurations, the Event may not be able to be Suspended or Closed due to OptRx being in a logging state.

### Sensor Setup

The crop Sensor Setup screen is where you can review and adjust sensor settings. You can access the Sensor Setup screen one of two ways:



OR





## Sensor Setup

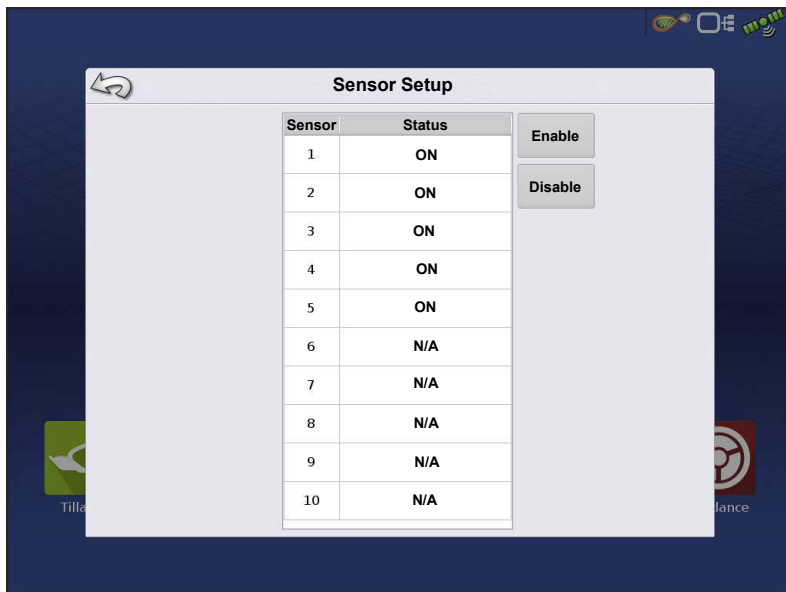

Sensor Setup screen appears. Each sensor is shown, with the status of “ON” or “OFF”.

**Enable**—Turns On the individual OptRx sensor.

**Disable**—Turns Off the individual OptRx sensor.

## Installation

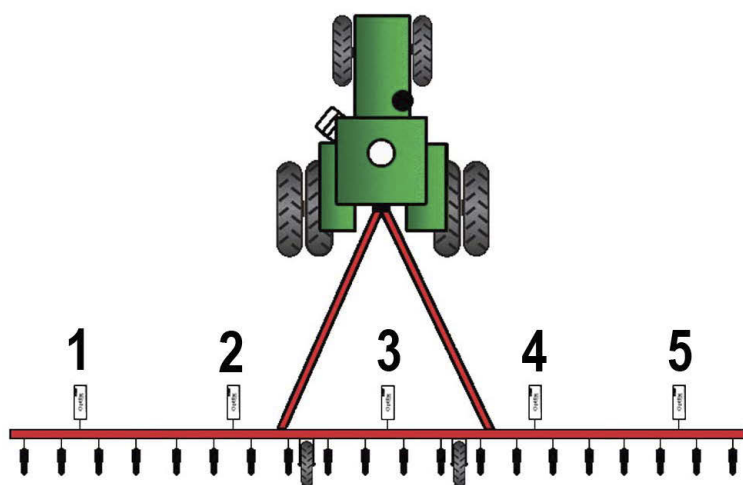

The display supports up to 10 OptRx sensors. For swaths that are 80 ft (24 m) or larger, five sensors or more should be used. For swaths less than 80 ft (24 m), a minimum of three sensors is recommended.

When installing sensor cables, you must install them in the correct order from left to right.

**NOTE!** If you do not install the sensors in their proper places, then the map created by the display will not accurately reflect actual field conditions according to row sensor placement.

---

## Checklist

- Sensors should be equally spaced apart. Sensors should not be mounted on the ends of the booms.
- Each sensor should be mounted so that it is centered over the top of a crop row.
- Sensor can operate 20 - 50 in. (51 -127 cm) above the crop canopy. Sensors perform best at 30 - 36 in. (76-91 cm).



**ATTENTION!:** A minimum of two sensors is required to actively apply product. With one sensor installed, you can only scan and record VI.

## Glossary of OptRx Terminology

**Active VI** — The Vegetation Index (VI) that the OptRx sensors read instantaneously during field operations.

**Max Rate** (shown at Crop Sensor Setup) — The highest amount of N that should be applied.

**Min Rate** (shown at Crop Sensor Setup) — The lowest amount of N that should be applied.

**N** — Refers to Nitrogen being applied.

**N Algorithm** — The OptRx Crop Sensor Module uses an N algorithm to calculate an N rate through a Sufficiency Index reading.

NDVI Normalized Difference Vegetation Near Infrared Reflective - Red Reflective  
Index =  $\frac{\text{Near Infrared Reflective} - \text{Red Reflective}}{\text{Near Infrared Reflective} + \text{Red Reflective}}$

NDRE Normalized Difference Red  
Edge =  $\frac{\text{Near Infrared Reflective} - \text{Red Edge Reflective}}{\text{Near Infrared Reflective} + \text{Red Edge Reflective}}$

**NDRE vs. NDVI**—Both are vegetation indices that compare scanned crop vigor and biomass (and algorithms) against the reference strip to assess plant health.

–NDVI is used in early growth stage crops as it picks up variances in small plant vigor better than NDRE

–NDRE does a better job at picking up variances in biomass at later growth stages

- 
- NDRE is more effective in later growth stages or in larger plants such as corn because the algorithm provides more response at higher vegetation index (VI) rates.
  - NDVI is more effective in earlier growth stages or in smaller plants where the algorithm is used to gain a more accurate reading at lower VI values. However, in later stages, NDVI's scanning tends to saturate at higher VI values which results in less response to changing VI values and recommended rates.

**Rate Increment** (shown in Crop Sensor Setup) — An optional increment that the display can use to round the N rate applied, if the operator desires. For example, if the operator enters the number 5 and the display is applying a rate of 27, the number will be rounded to 25.

**Reference Strip** — The healthiest portion of your field where you are satisfied that N is sufficient. This allows a baseline of optimum crop performance that the system can compare against other cropland.

**Reflectance** — The light reading of the plant measured by individual light spectral wavelength. The comparison of different reflectance values can be used to determine the health of the plant.

**VI** — Vegetation Index. The recorded value from remote sensing that displays a comparison of crop vigor and biomass of the scanned plant. This value, which is taken from a reference scan of a Reference Strip, uses a ratio that indicates the health of the plant. NDVI and NDRE are examples of different vegetation indexes.

**VI Minimum** (shown at Settings screen) — The threshold below which the Crop Sensor applies the minimum rate. This setting is used to apply a minimum amount of N on ground with damaged or diseased crops.

**VI Reference** (shown at Settings screen) — The value of a healthy crop biomass used in reference for calculating the proper N application rate. The VI Reference value is determined by the creation of a Reference Strip.

**VI Zero** (shown at Settings screen) — The threshold below which the Crop Sensor applies a zero rate. This setting is used to prevent applying N over bare ground or permanently damaged crops.

## Troubleshooting OptRx Error Messages

The OptRx Crop Sensors have error messages to inform the user of complications in communication and performance. The following error messages are the most common ones. Follow the recommended troubleshooting steps to correct these errors.

---

**Error Message:** “Sensor Lost Communication”

**Possible Cause:** The cabling between the OptRx sensor and the ACS Master Module is disconnected.

**Solution:** Check all connections and cables for disconnections, cuts, breaks, or crimps in the line.

**Error Message:** “Bad Data”

**NOTE!:** The “Bad Data” error messages are disabled when user does not intend to log data or while the reference strip is being created.

**Possible Cause:** The sensors are either too far from the crop or too close to the crop.

**Solution:** Adjust the height of the sensor to approximately 30 inches (76 cm.) above the crop canopy by adjusting the boom height or the height on the crop sensor bracket

**Error Message:** “Sensor Failure”

**Possible Cause:** The sensors are either too far from the crop or too close to the crop.

**Solution:** Adjust the height of the sensor to approximately 30 inches (76 cm.) above the crop canopy by adjusting the boom height or the height on the crop sensor bracket.

**Error Message:** “Sensor Failure”

**Possible Cause:** There has been a drop in voltage to the OptRx Crop Sensors.

**Solution:** Check voltage on the high current power cable to ensure voltage provided to the sensors is approximately 12 V.

**Error Message:** “Too Few Sensors for Application”

**Possible Cause:** The OptRx configuration must have at least two working sensors to make an N rate recommendation.

1. There has been a drop in voltage to the OptRx Crop Sensors, or
2. The OptRx Crop Sensor is not detecting communication from the OptRx Crop Sensor Module

**Solution:** Perform the following actions, depending upon the possible cause of the error:

If 1), check cabling.



---

If 2), check the OptRx Diagnostic screen to determine if the OptRx Crop Sensors are still communicating.

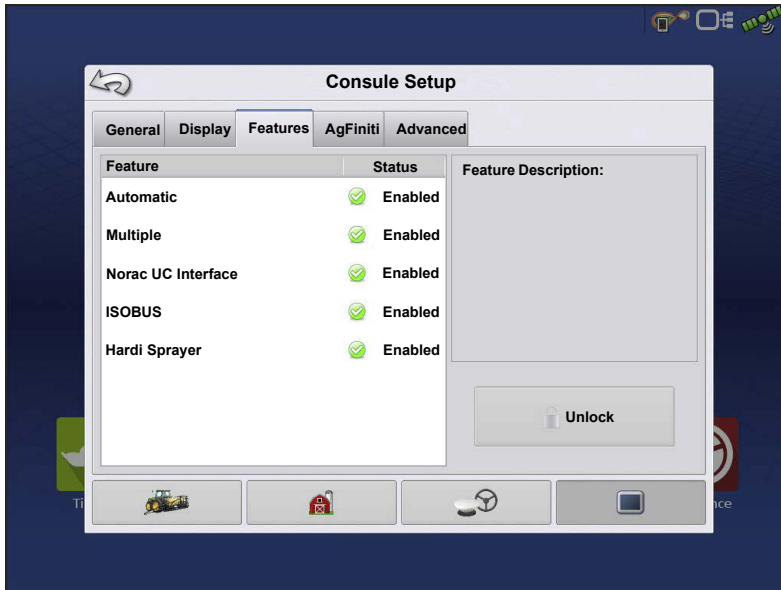

## Norac Unlock



The Features Tab is where you can enter unlock codes. Unlock codes are unique to the serial number of each display and the feature registration number. You must supply these numbers to your dealer when purchasing any unlock codes. Press  to enter the unlock code and press  to enable the feature.

## Locked or Unlocked

Norac UC5 can be used with or without an unlock but how you setup and run the system differs depending on whether the system is locked or unlocked and using CAN A or CAN B.

	Locked	Unlocked
<b>CAN A</b>	No Functionality	Setup using Ag Leader Screens Operate using Ag Leader Screens
<b>CAN B</b>	Setup using Universal Terminal Screens Operate using Universal Terminal Screens	Setup using Universal Terminal Screens Operate using Ag Leader Screens

## Create Configuration

To create a configuration, make the following button presses to start the Configuration Wizard and then follow the instructions given on the display. The configuration can be started in two places:

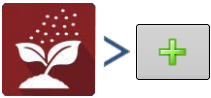

OR



OR



The wizard will guide you through the process of selecting or creating a vehicle, implement and controllers.

Your Operating Configuration will then be viewable when you start a new Field Operation with the Field Operation Wizard.

## Setup Configuration





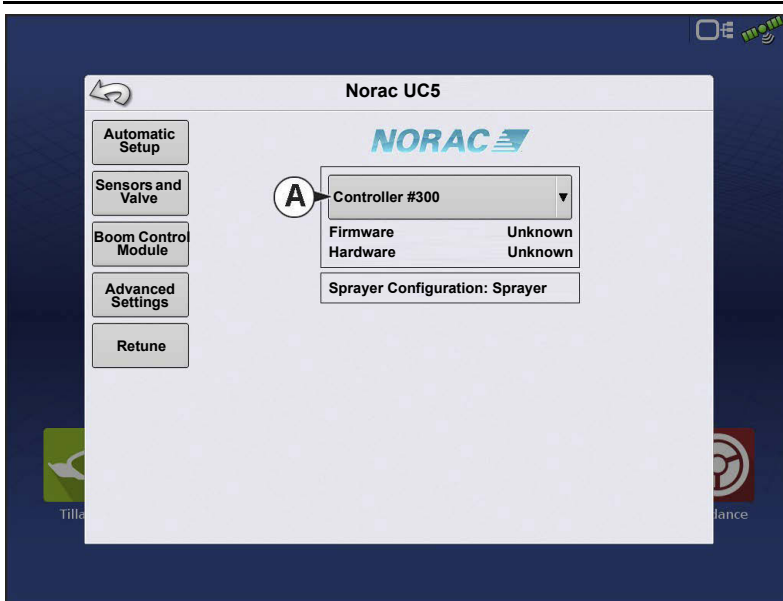

## A. Norac Devices drop-down

**menu**—The drop down menu shows the devices communicating on the NORAC UC5 CAN Bus along with the serial number of each device. The Firmware Version and Hardware Revisions of your NORAC UC5 devices are shown underneath.

• **Automatic Setup**—Automatic Setup walks through a series of steps that configures the NORAC UC5

electronics to the sprayer hydraulic functions. You must perform an Automatic Setup routine after the NORAC UC5 system is installed. The following items are configured during an Automatic Setup routine:

- Sprayer Make and Model
- Input module wiring and configuration
- Number of sensors and location
- Sensor zero point
- Valve deadzone and gain values.



**NOTE!:** For detailed Automatic Setup information, see the NORAC UC5 manual.

- **Sensors and Valve Drivers**—Opens the Sensor and Valve Driver Settings screen (for more detail see the next page).
- **Boom Control Module**—Turn motion detection on/off, choose source as GPS or AUX.
- **Advanced Settings**—For use by a technician.
- **Retune**—From time to time it may be necessary to recalibrate (Retune) the UC5 electronics to your sprayer's hydraulics. Examples of such times are:
  - When a hydraulic solenoid valve is changed.
  - When the hydraulic pump is changed or adjusted.

- 
- When the normal working temperature of the hydraulic oil has shifted significantly from when the system was previously calibrated.

If you are running a pull type sprayer and use different tractors to operate the sprayer, you should run the Retune procedure each time the tractor is changed. If you have a flow control for the boom hydraulics, set it prior to tuning. If you change the flow setting by more than 20 percent, you should Retune.

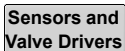
Press  to open the Norac UC5 Setup.

## General Tab

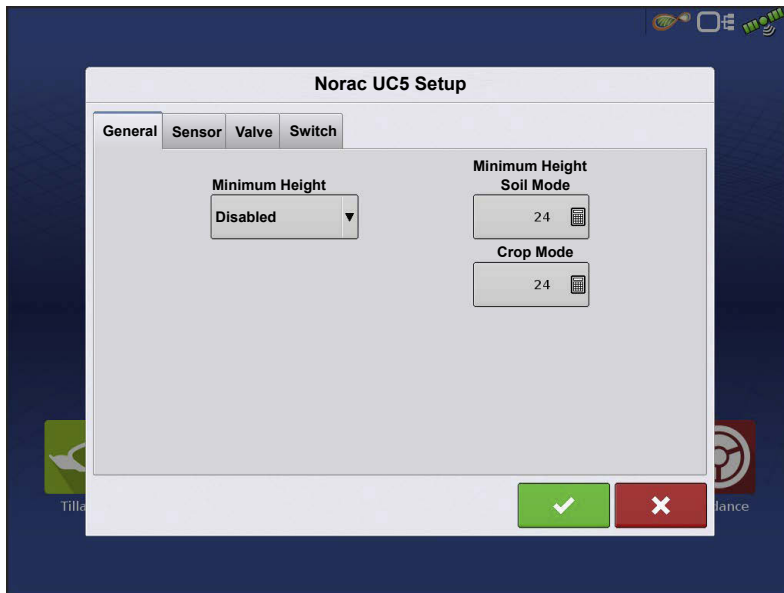

Minimum Height Mode includes three selections:

- **Absolute**—no sensors are allowed to move closer to the target than the minimum height setting.
- **Relative**—no sensors are allowed to move closer to the target than the distance of the target height minus the minimum height setting.
- **Disabled**—Disables the minimum

height mode.



**NOTE!** “Target” refers to the ground in Soil Mode, and the crop canopy in Crop Mode.

- **Minimum Height**—If desired, press  to adjust the following settings.
  - **Soil Mode** - The minimum height setting when operating in Soil Mode.
  - **Crop Mode** - The minimum height setting when operating in Crop Mode. Also, consult the NORAC UC5 manual for more information.

## Sensor Tab



List of each sensor type and serial number, add or remove a sensor, input nozzle height.

## Valve Tab

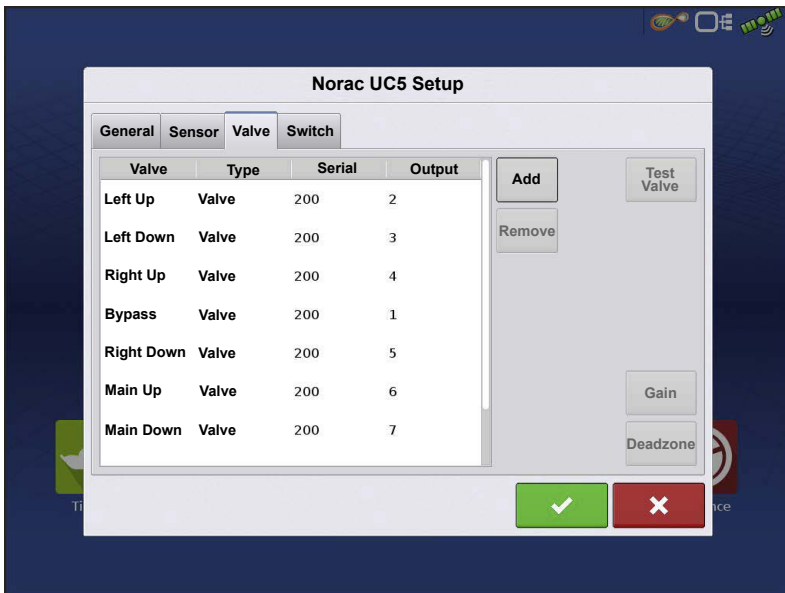

List of each valve, type, serial number, and output. Add or Remove a valve, test valve, adjust gain and deadzone.

## Switch Tab

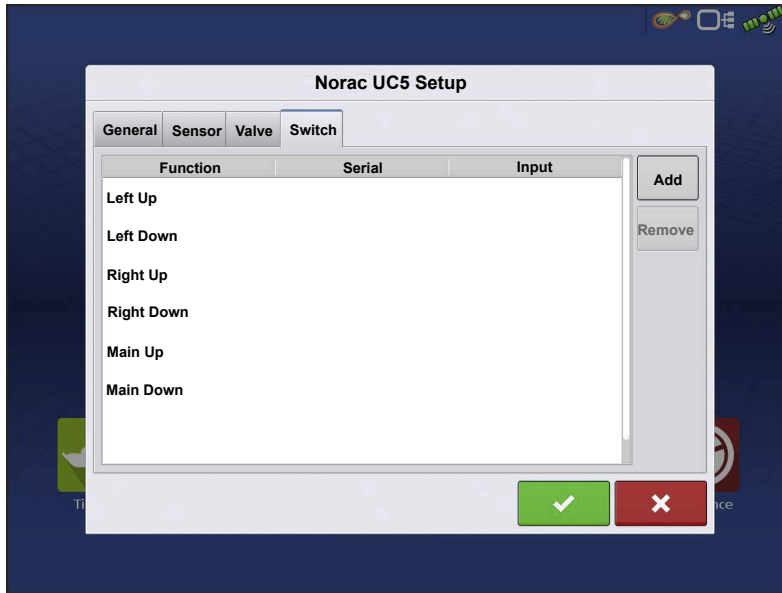

List of switches, functions, serial numbers, and input. Add or Remove a switch.

## Load Configuration



Press the Application button from the home screen. This will take you through the steps needed to load a configuration.

## Engage button



If the NORAC UC5 Boom Height Control is included in your Operating Configuration, then the NORAC Engage button appears on the display's Task Bar. The Engage button enables boom height control. This button is green when the NORAC UC5 system is engaged; and grey when disengaged. Press on this button to engage and disengage the NORAC UC5 Boom Height Control.

This button can be used to toggle back and forth between Automatic Mode and Manual Mode.

- When you enable **Automatic Mode**, this button turns green and the display beeps three times.
- When you disable **Automatic Mode** on any part of the boom and the display switches to **Manual Mode**, this button turns white and the display beeps twice. If less than the full boom remains in **Manual Mode**, the display will continue beeping twice every three seconds.

## Boom Height Control Options Button

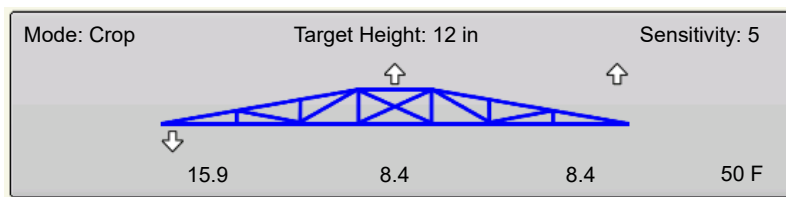

At the center of the Map screen's Equipment Tab, the Boom Height Control Options button displays data on NORAC UC5 Run Time

performance.

- The Boom Icon appears as blue when in Automatic Mode; and black when in Manual Mode. The right, left and center sections appear independently on this icon. Press the Boom Height Control Options button to open the Boom Height Control Options screen.
- The white arrows indicate the direction that the boom section is being commanded to move. The arrows shown around the boom appear either 1) In Automatic Mode, or 2) When the boom is in Manual Mode and the boom is moved by the operator.
- **Mode**—Indicates whether the Boom is in Crop Mode, Soil Mode, or Hybrid Mode.
- **Target Height**—The desired boom height above the ground (for Soil Mode), or the crop canopy (for Crop Mode).
- **Sensitivity**—Adjusts the boom response. Higher values make the height control more responsive.
- **Distance Between Boom and Target**—The numbers that appear below the Boom Icon show the distance between the boom section and the target.
- **Temperature**—Shows the measurement of the outside ambient air temperature.

## Boom Height Control Options Screen

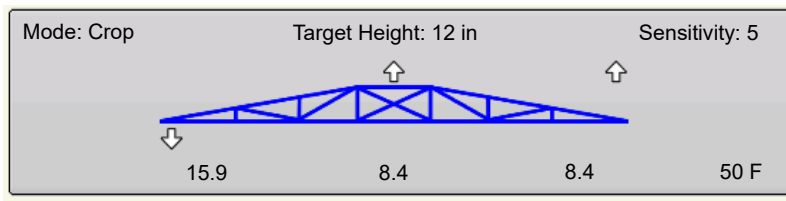

Pressing the **Boom Height Control Options** button opens the **Boom Height Control Options** screen.

## Boom Height Control Options

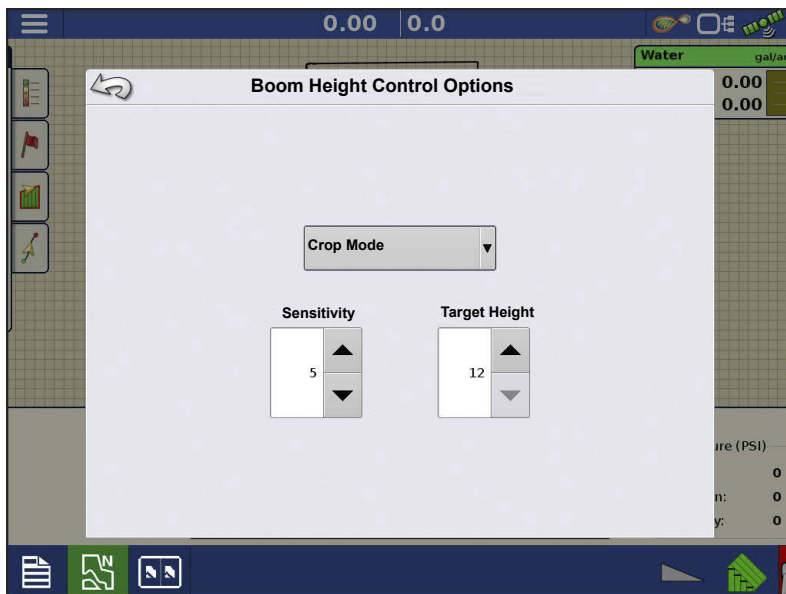

At this screen, you can adjust the boom's Mode, Sensitivity and Target Height.

• **Mode**—The drop-down menu is where you can choose one of three modes:

a. **Soil Mode**—the UC5 controls boom height relative to the distance from the soil.

b. **Crop Mode**—the UC5 controls boom height relative to distance from the crop canopy.

- c. **Hybrid Mode**—The UC5 controls boom height using a combination of soil and crop readings. For detailed Hybrid Mode information, see the Norac UC5 manual.
- **Sensitivity**—Adjusts the boom response. Higher values make the height control more responsive; settings range from 0-10.
  - **Target Height**—User-defined boom height in relation to the selected control mode.

## Boom Height Diagnostics

The Boom Height Diagnostics screen shows all data for individual sensors, including Height, Roll and Temperature.



To go to the Boom Height Diagnostics screen, press on the **Device Information** button. At the **Devices** screen, highlight the item marked **NORAC UC5** then press the **Diagnostics** button.

**Boom Height Diagnostics**

Water 0.00 gal/ac  
0.00

**General**  
Control Mode: Manual  
Target Height: 30.5  
Remote Switch: Manual

**Crop**  
30.5

**Boom Control State**  
Left: Manual  
Center: Manual  
Right: Manual  
Roll: Manual

**Sprayer Configuration: Sprayer**

Location	Serial	Height / Roll	Temperature
1	100	0 cm	21.0 °C
2	103	0 cm	21.0 °C
3	101	0 cm	21.0 °C
4	104	0 cm	21.0 °C
5	102	0 cm	21.0 °C
6	105	0.0 °	N/A
7	106	0.0 °	N/A

Pressure (PSI): 0  
n: 0  
y: 0

The NORAC UC5 Diagnostics screen appears.



UC5 Stand-Alone System

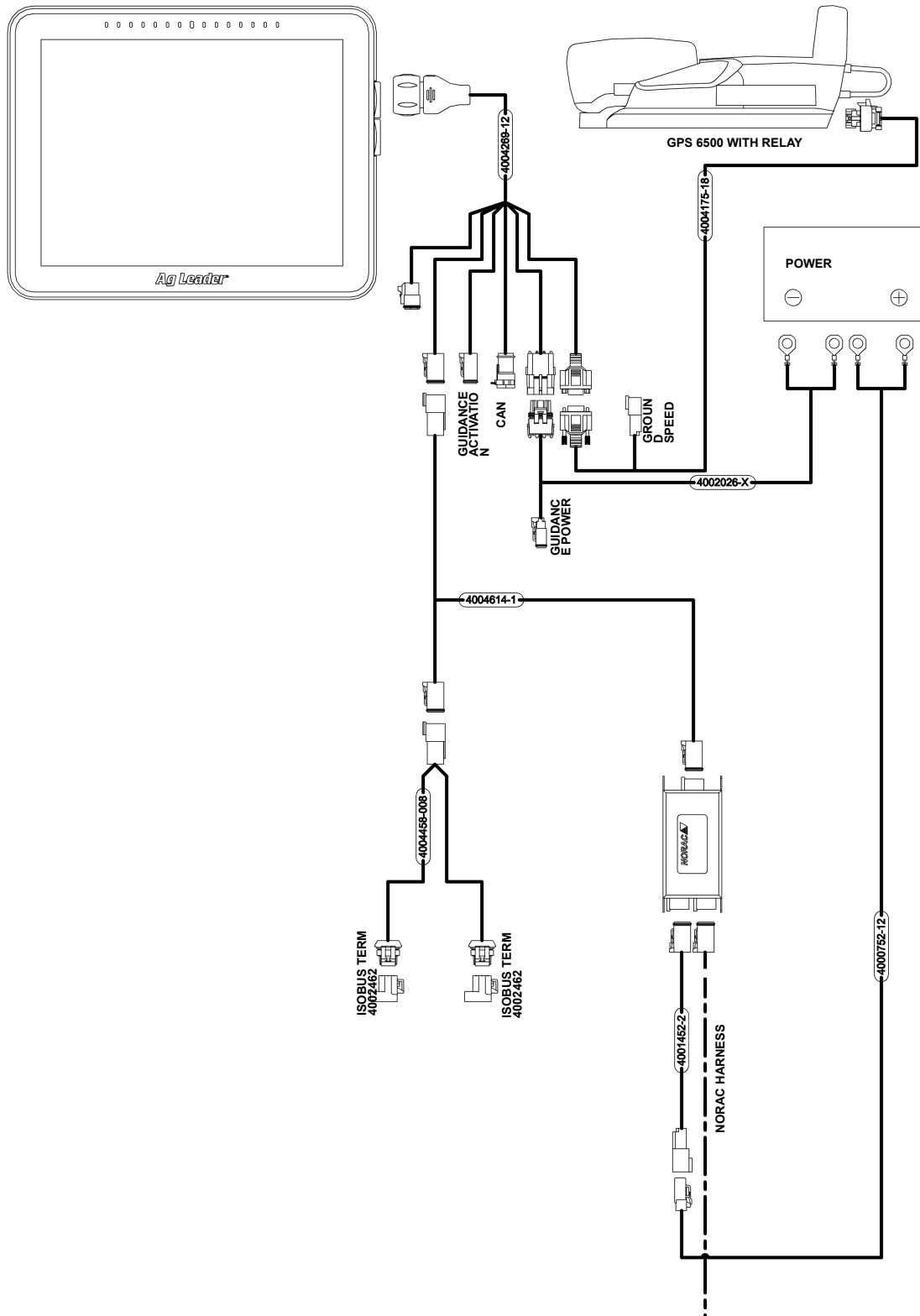

# UC5 Self-Propelled with Modules

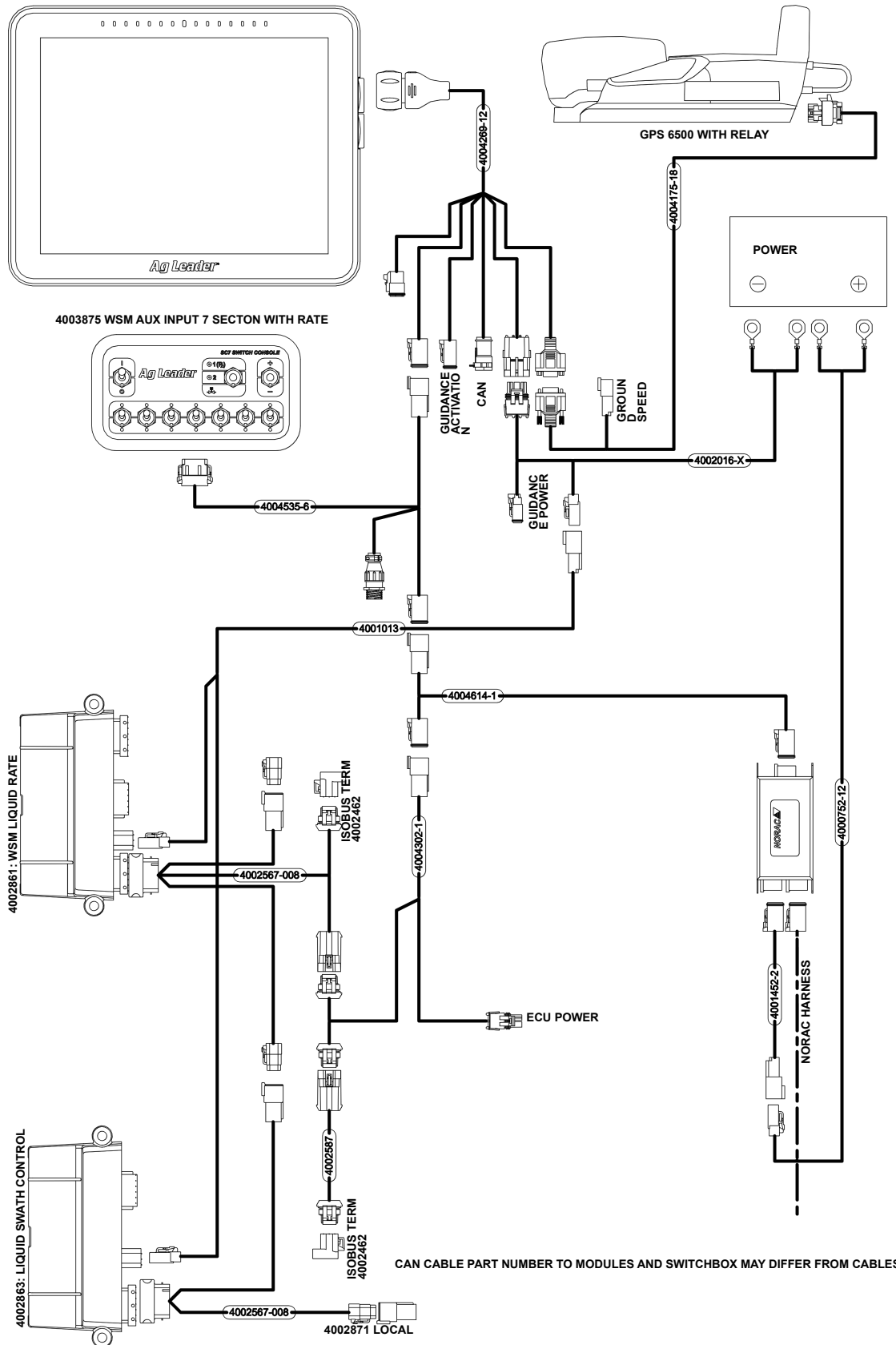

UC5 ISOBUS Vehicle

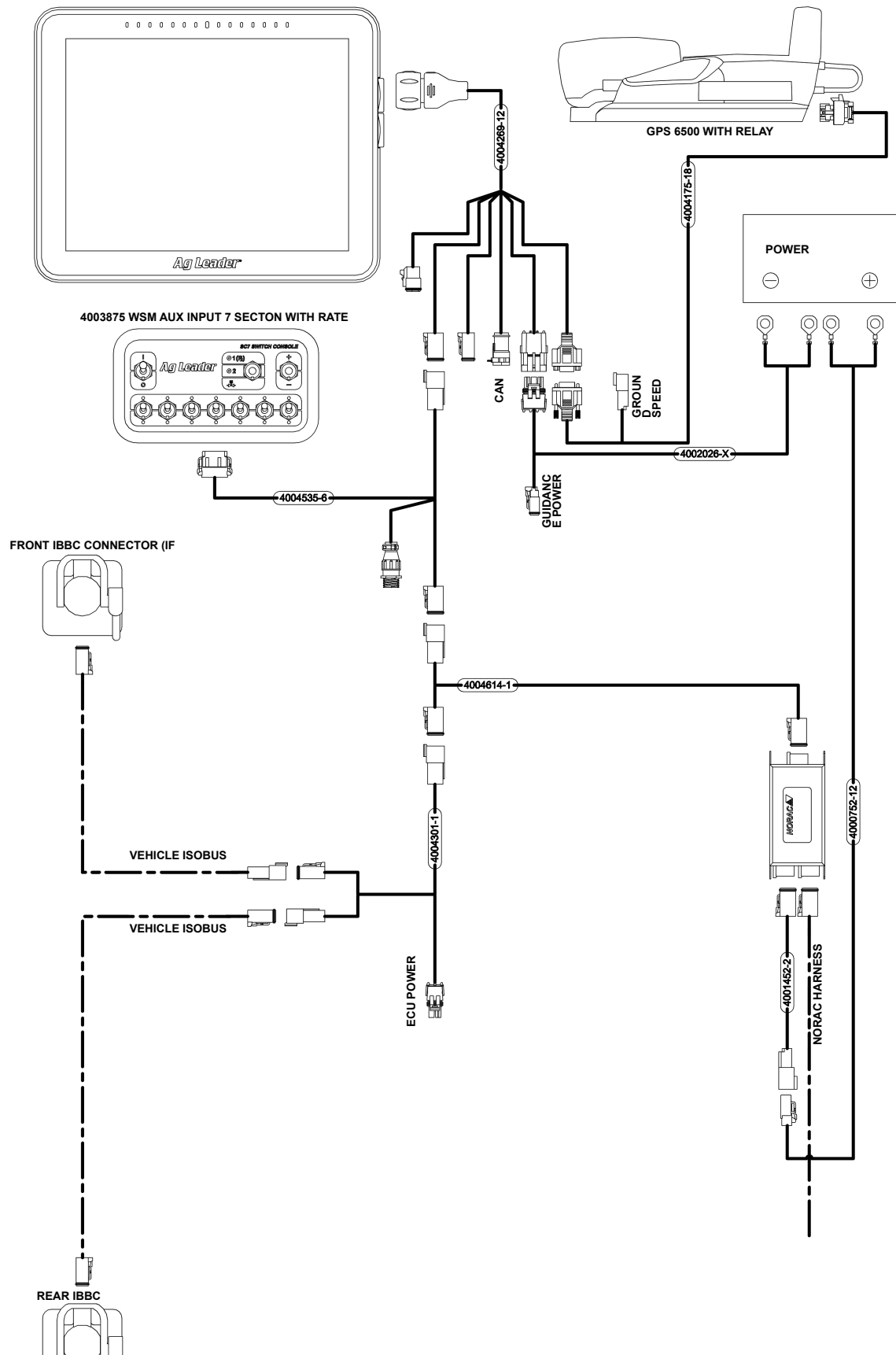



## Spinner Spreaders

DirectCommand™ for spinner spreaders is capable of controlling the product conveyor, spinner speed, monitoring bin level, and providing multiple prescription rate control for up to five granular products. The control modules support PWM, motorized servo, Mark IV.2, Mark IV.4, and Mark V hydraulic control valves. DirectCommand granular application system also supports application control of multiple bin spreaders.

## Load Configuration



Press the Application App from the home screen. This will take you through the steps needed to load a configuration.

## Map View

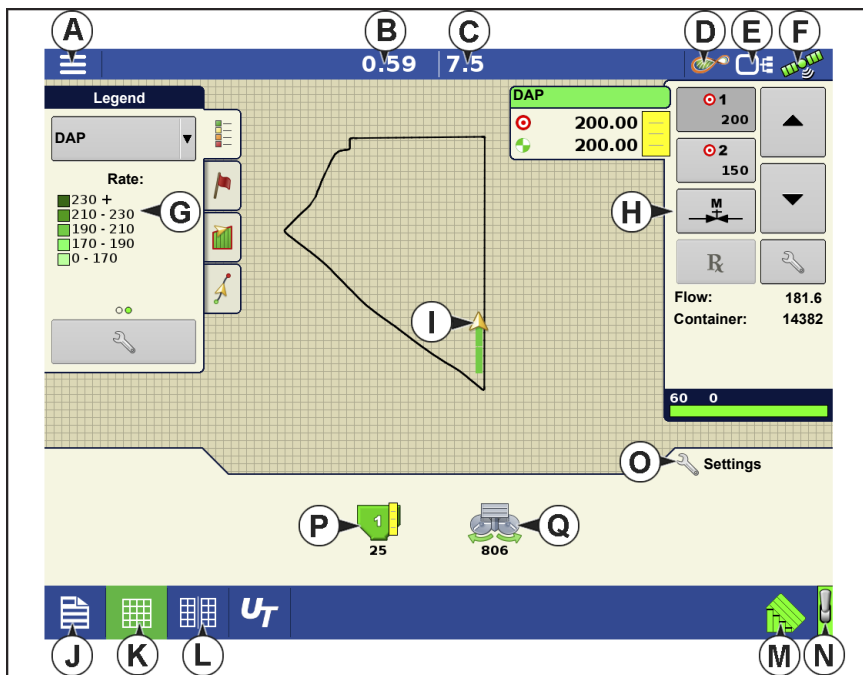

Once a configuration has been completed, the Map View screen appears

- A.Menu button
- B.Total Logged Field Area
- C.Ground Speed
- D.AgFiniti® Status
- E.Diagnostics
- F.GPS Signal Indicator
- G.Display Legend
- H.Product Control toolbox
- I.Vehicle Icon
- J.Event Summary
- K.Map View
- L.Split screen

M. AutoSwath™

N. Master Switch Status

---

O. Settings

P. Bin Level

Q. Spinner Speed



**NOTE!:** Pressing the Map View button will cycle between the available Map Screen views, and the appearance of the Map View button changes.

## Product Control Toolbox

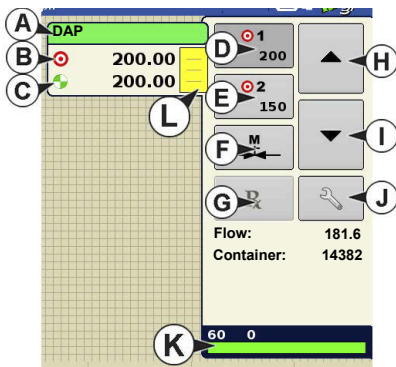

During DirectCommand Run Time operations, the Product Tab(s) are shown in the upper right-hand side of the Map screen. Press the Product Tab(s), and an extended view shows the Rate buttons, Manual Valve Control button, Prescription button, Rate Increase and Decrease arrows, and the Rate Setup button.

A. Product

B. Target Rate

C. Actual Rate

D. Rate 1 button

E. Rate 2 button

F. Manual Valve Control

G. Prescription button

H. Rate Increase arrow

I. Rate Decrease arrow

J. Rate Setup button

K. Section Status Indicator

L. Container Level

**Target Rate**—The Target Rate is desired application rate.



**NOTE!:** In some conditions, the Target Rate may increment more quickly than the Actual Rate.

**Actual Rate**—The Flow Sensor returns the actual rate being applied.



**NOTE!:** In some conditions, the Actual Rate may increment slower than the Target Rate, or its numeric values may vary before matching the Target Rate.

**Container Level**—The Container Level shows the amount of product in the container.

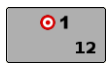

**Rate 1 and Rate 2 buttons**—The Rate 1 and Rate 2 settings represent preset application rates that allow operators to quickly change between desired target rates for each individual product.

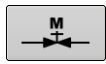

**Manual Valve Control button** — The Manual Valve Control button allows operators to specify the position of the control valve. Operators use this option to prime the system before application or clean out the equipment at the end of the day.



**Rate Increase and Decrease Arrows** — allow Product Application Rate to be

changed according to the Target Rate Increment. In using manual valve control, the increase and decrease buttons allow the position of the control valve to be defined by the operator.



**Prescription button**





**Rate Setup button**

## Rate Control Settings

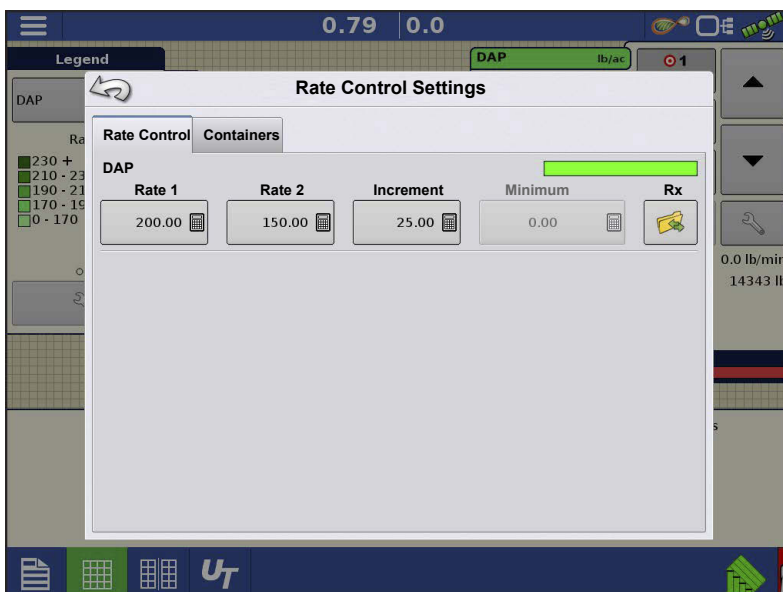

Adjust the Rate 1 and Rate 2 settings shown at the Product Control Toolbox on the Map screen, as well as import application product prescriptions. To access the Rate Control Settings screen, press the Rate Setup button on the Product Control Toolbox. The Rate Control Settings screen appears.



**Rate 1 and Rate 2** — The Rate 1 and Rate 2 settings represent preset application rates that allow operators to quickly change between desired target rates for each individual product. Press  to enter the desired amount.

**Increment** — The Increment button allows operators to specify the increase or decrease amounts for a

specified rate by using  /  on the Product Control Toolbox. Press  to enter the desired increment.

**Prescription** — To load a map-based prescription file, press the Prescription button.

Refer to [Loading Prescriptions](#) on [page 814](#) for further details.

**Minimum Flow** — (Used for DirectCommand Liquid Applications only). This setting is used to maintain a consistent spray pattern. The display will not allow flow to drop below the entered setting. Set to flow at the lowest operating pressure for the selected spray tips with all sections on. When spraying with one or more boom sections off, the system automatically reduces the minimum flow setting according to the reduced spray width. To adjust this setting, press  and enter the desired numeric value.

## Container Level Settings

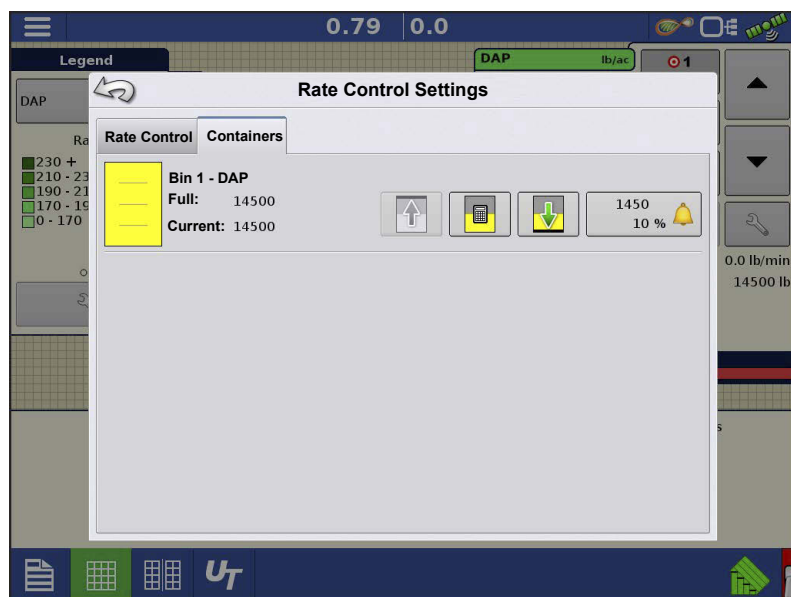

When filling or emptying container, use the Container Level portion of the Rate Control Settings screen to update the amount of product in the containers.





**Tank Fill** — The Tank Fill button increases the container level logged in the display to the user-defined maximum volume (specified in the Container Setup Wizard).



**Tank Empty** — The Tank Empty button decreases the container level logged in the display to zero.

**Tank Partial Fill** — The Tank Partial Fill button increases the container level



logged in the display to specific amount that you specify by pressing calculator icon. Pressing the Partial Fill button summons the Adjust Container Amount screen.

## Adjust Container Amount

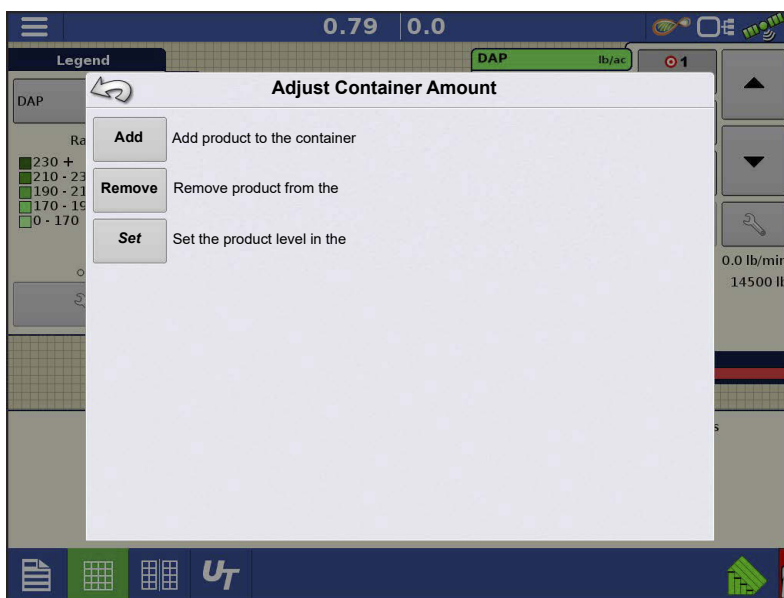

•**Add** — Adds product to the container.

•**Remove** — Removes product from the container.

•**Set** — Sets the product level in the container.

## Tank Alarms

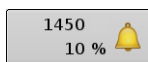

The Container Alarm button, which appears on the right of the Container Level portion of the Rate screen, displays the capacity of your tank as well as the percentage at which the Low Container Level warning will sound. To adjust these settings, press the button and the Container Alarm screen appears.

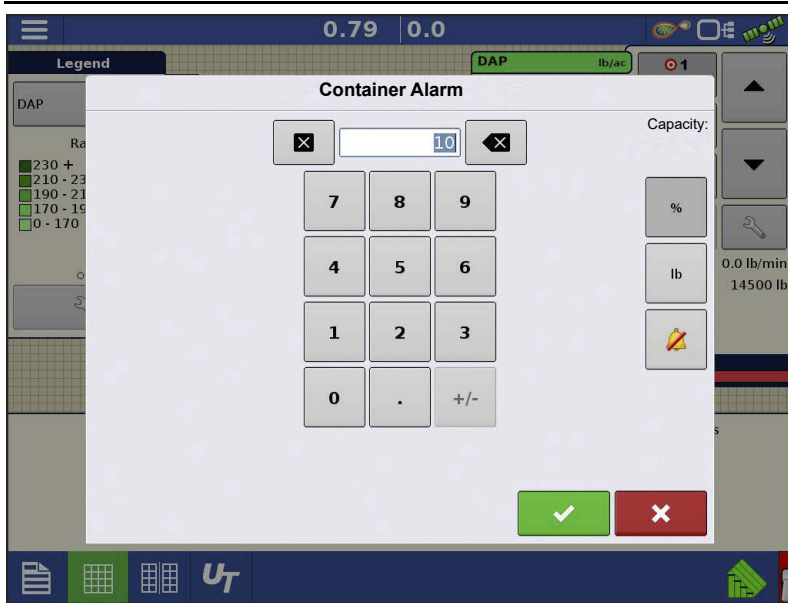

If you wish to adjust your container level warnings, use the following buttons on the right-hand side of the Container Alarm screen to make these adjustments.

The **Percentage (%)** button sets the warning threshold according to the percentage of product left in the tank. In the example above, the threshold is set at 10 percent.

The **Units of Measurement** icon sets

the warning threshold according to the amount of product left in the tank. This icon is named according to the container's units of measurement you specified during the Controller configuration procedure.

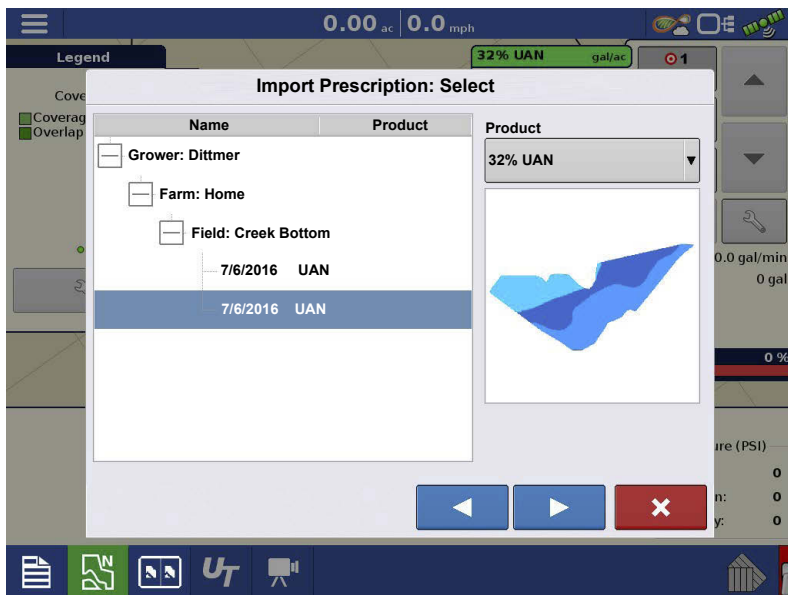

The **Disable Low Container Level** button, which appears as a bell with a red slash across it, disables the Low Container Level warning.

## Loading Prescriptions



1.  Press the Rate Setup button on the Product Control Toolbox.

2. Press the Load Prescription button.

3.  Using an inserted USB or AgFiniti Cloud, search for and highlight the correct .agsetup, .irx, or shape file and press .

4. Select the prescription in the Select

Prescription screen, and select the correct controlling product from the Product dropdown box. A preview prescription map is displayed. Press .

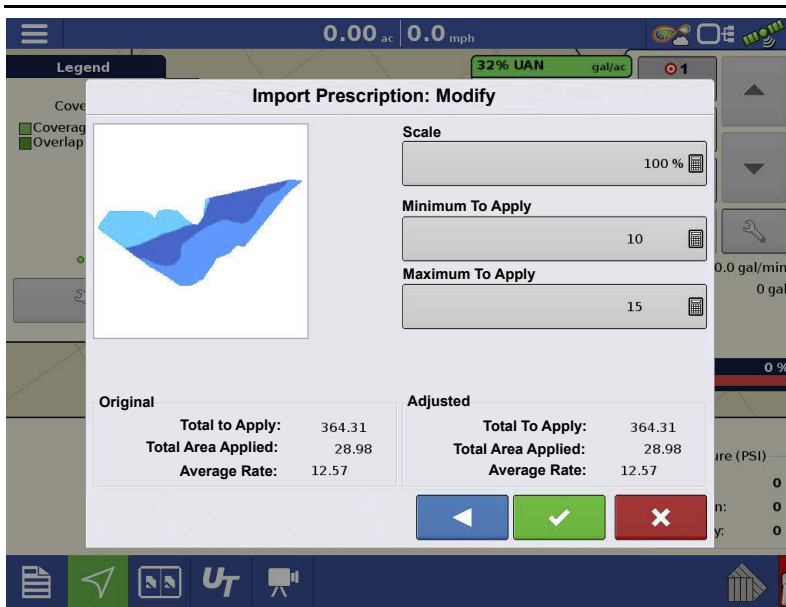

5. In the Modify Prescription Screen the prescription scale, minimum to apply, and maximum to apply can be changed. As the three parameters are changed, the adjusted total to apply and average rate will update accordingly.

6. Press the .

7. After returning to the Mapping Screen, the prescription will appear on

the map while in a North Oriented view.

## Shape File Conversion

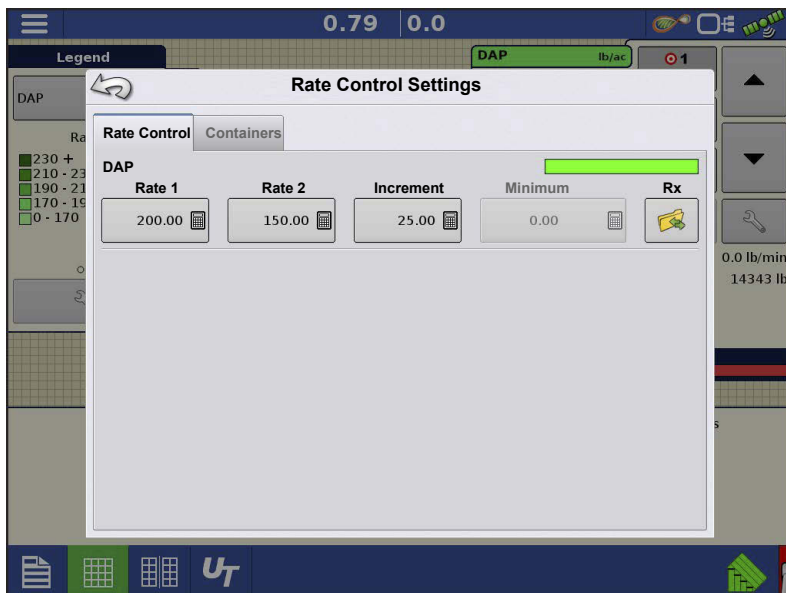

What is commonly called a shape file is actually a collection of three different files. All three of the files are required and must be present on the USB drive for the system to use shape file groups for variable rate product application. A single "shape file" can contain recommendation rates for multiple products.

1. Press  on the Product Control

Toolbox.

The Rate Control Settings screen appears

2. Press the Load Prescription button .

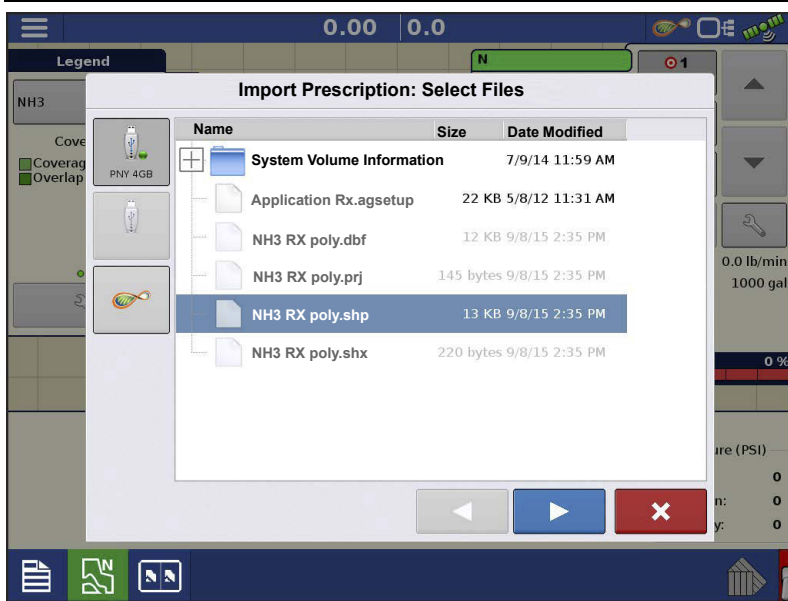

3. The Select File screen appears. Highlight your desired .shp file and press .

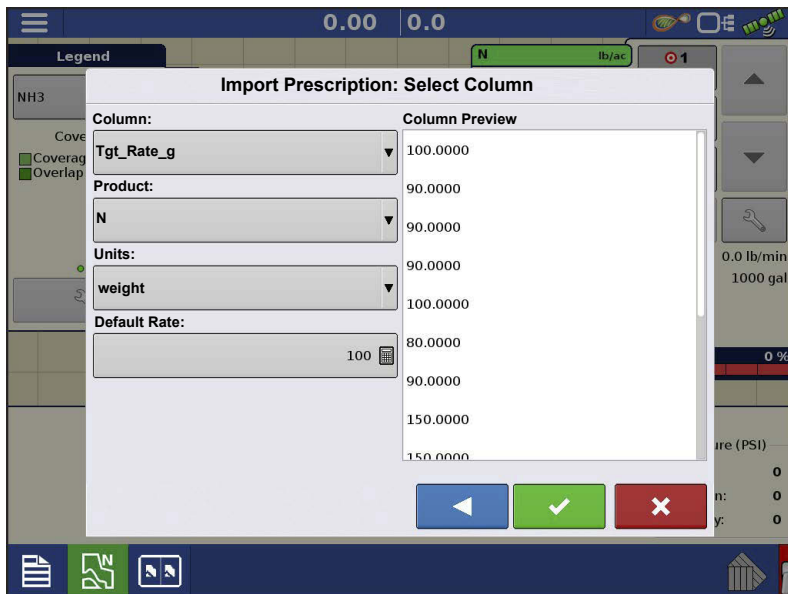

4. **Select Column From Shape File**—Select the column that contains the product recommendation rate. The list on the right side of the dialog shows sample data from the selected column.

5. **Select Units**—Select the controlling units for product application.

6. **Default Rate Setting**—The system assigns a default rate. Use the on-screen keypad to edit the value if

desired.



**NOTE!:** Select the product and units that the shape file prescription was made for. Selection of the wrong data column or unit will result in misapplication of product.



**ATTENTION!:** The only time the default rate is used by the system during product application is if the Rate Outside of Field selection is set to " Rx default". This setting is located in the equipment configuration settings portion of configuration setup. If the Rate Outside of Field selection is set to "Rx default", the default target rate will be used when the vehicle exits the area covered in the prescription map.

## Creating Products

Creating application products including dry fertilizer blends can be completed upon initial setup or from the Product Selection screen of the Field Operation Wizard when starting a field operation.

### Creating Single Products

To create a single product, to be added to a blend or to be applied by itself, use the on-screen wizard described in the following steps.



1. **Select Product Type**—Use drop-down menu to select Product and press  to continue.

2. **Select Product Units**

When selecting the following fertilizers, use drop-down menu to select the product units:

- Ag Lime
- Pell Lime
- User Defined Lime
- User Defined N-P-K
- User Defined Micronutrient
- Other

Press  to continue.

3. EPA Product Number (Optional)

---

Check box if product is a Restricted Use Pesticide

4. Manufacturer name if applicable

Manufacturer name can be added to the drop-down menu by pressing .

### 5. Enter Product Name

Default product name appears. Press  to enter a new name.

Press  to complete product setup or press  to return to Configuration Setup screen without making a change.

Created product should appear under the Application heading located on the Product tab of the Configuration Setup screen.



**NOTE!:** Some Fertilizer and Carrier product types are predetermined in the display. These product names cannot be edited. Their Manufacturer and EPA Numbers can be edited after the product is created. Examples are: Fertilizer>DAP or Carrier>30% UAN.

### Creating Dry Fertilizer Blends

Dry fertilizer blends are set up using the on-screen wizard described in the following steps.



6. From the Type drop-down menu select Dry Blend

From the Define By drop-down menu select:

- Total amounts - to define blend by amounts going into the bin
- Rate/acre - to define blend by the amounts going on an acre

Press  to continue.

7. From drop-down menu select base units.

Press  to continue.

8. Press  to start the process of adding components to the blend.







**NOTE!:** Any liquid herbicides set up within the system can be added to create an impregnated blend product.

9. Select the desired component from the drop-down menu.



**NOTE!:** More than 7 products can be put part of a Mix/Blend but only 7 or fewer can be active at the same time.

- A new product can be set up at this time by pressing  and following the Product Setup Wizard.
- Press  to add selected product or press  to return to Add Mix/Blend screen without adding a product.



10. Press  to add an additional component.

11. When all components have been added press .

12. Enter Manufacturer name if applicable.

- Manufacturer name can be added to the drop-down menu by pressing 

13. Press  to enter a unique name for the blend.

14. Press  to complete the process of setting up the dry blend or press  to return to Configuration Setup screen without adding a mix.

Created blend should appear under the Application heading located on the Product tab of the Configuration Setup screen.



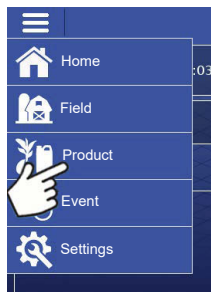

Dry Blend/Product Template indicator.

# Configure Product Mix

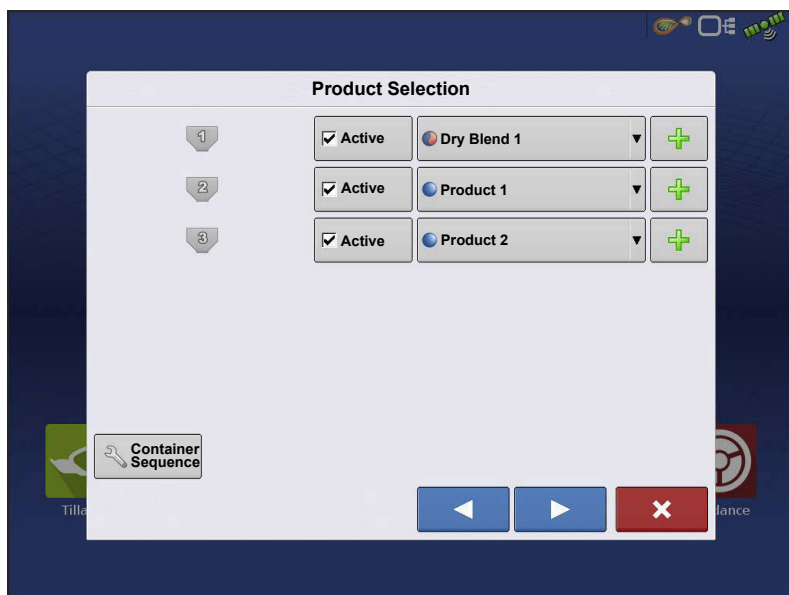

1. When using a Dry Fertilizer Blend, the mix contents and amounts are defined in the Configure Product Mix screen available in the Event Setup Wizard, or Product button in the main menu.



2. Select product from the drop-down list or press  to create a new one.

More than 7 products can be part of a Mix/Blend but 7 or fewer can be active at the same time.

Press  to continue.



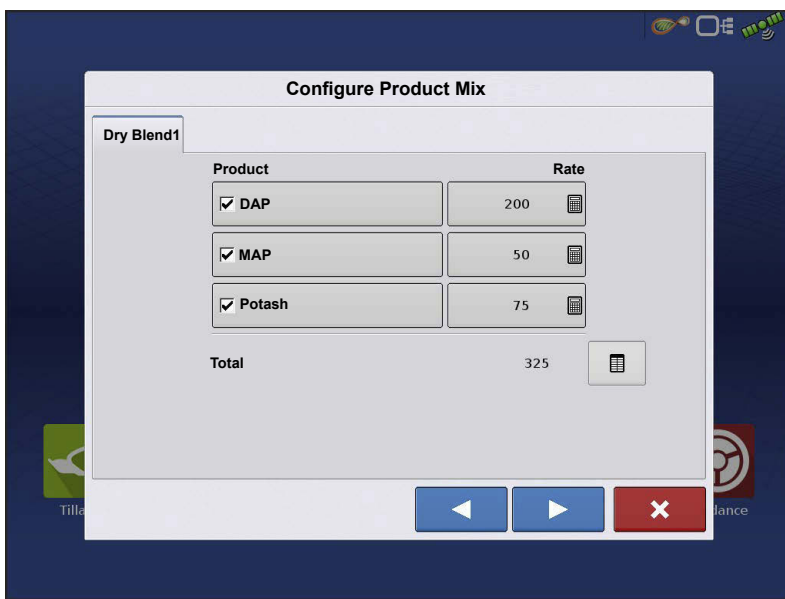

### 3. Configure Product Mix

Product Blends can be adjusted after they are created by:

- a. Activating or de-activating products
- b. Changing rate or total amount of a product
- c. Changing total amount of the product or overall rate of product application

4. When a Product Blend is setup using rate/area, the Mix Calculator

 can be used to show how much

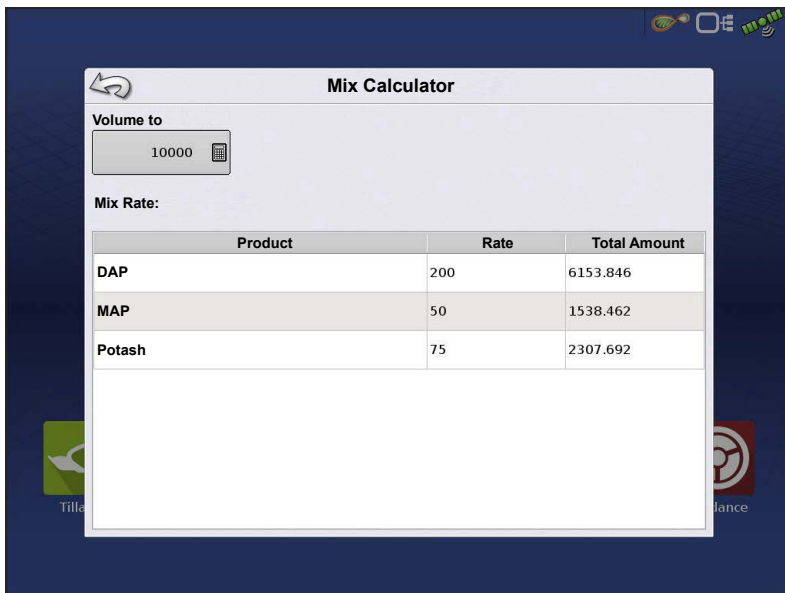

of each product to put in the tank when the user enters the desired amount to fill.

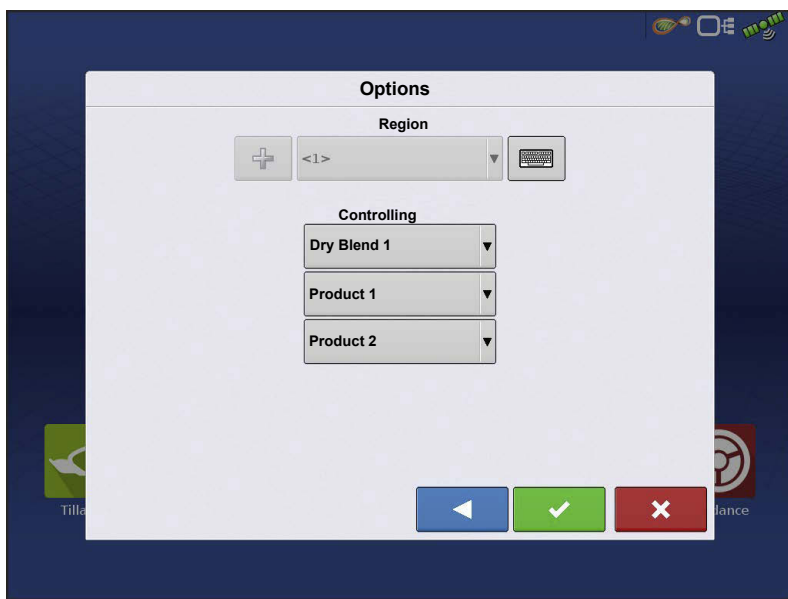

5. Press the Volume to Calculate button and input the total volume.

Table will give the user the amount of each product to put in the tank.



6. Select Region from the drop-down menu or press  to name the Region. Verify the Controlling Product for the Product Blend. Press  to load the Event to the Map Screen, or press  return to Home screen without setting up an Event.

## Create Configuration

A wizard will guide you through the process of selecting or creating a configuration with application settings.

The configuration can be started in two places:



OR

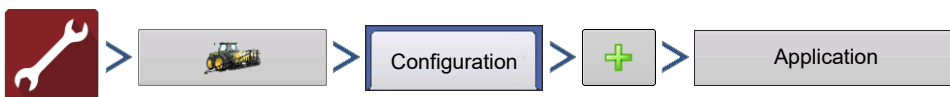

Your Operating Configuration will then be viewable when you start a new Field Operation with the Application Wizard.

You can also use the **Manage Equipment** button to create or edit specific vehicles and implements.

## Container Sequencing

Container Sequencing functionality allows application of the same product (discrete products or blends) sequentially from multiple containers. When product container is low or empty, system automatically advances product application to the next designated container in the sequence.



**NOTE!:** Container Sequencing functionality is only supported in the InCommand™ 1200 display. The InCommand 800 display does not support sequencing functionality.

### Container Sequencing Configuration

Complete the following steps to set up container sequencing.

1. Select  from Home screen.
2. Select Season, Grower, Farm, Field

Press  to accept and continue.

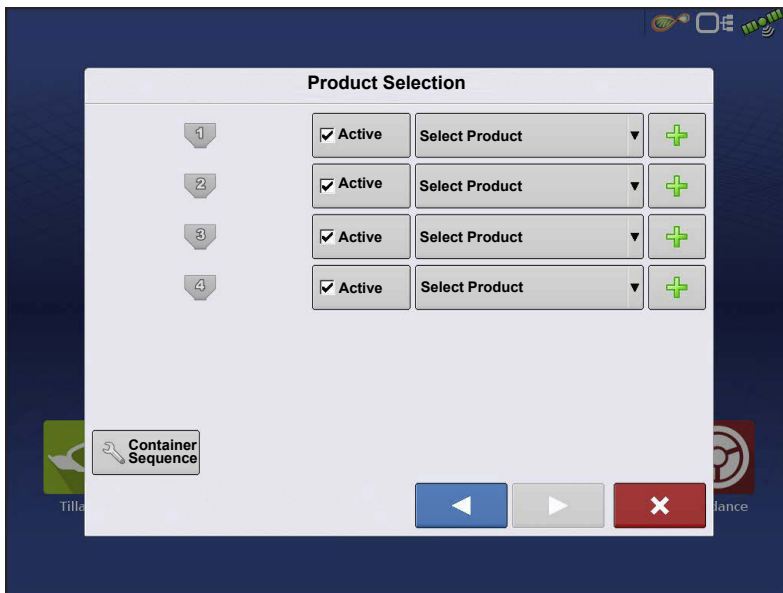

3. Press the **Container Sequence** button to add container sequencing to current configuration.

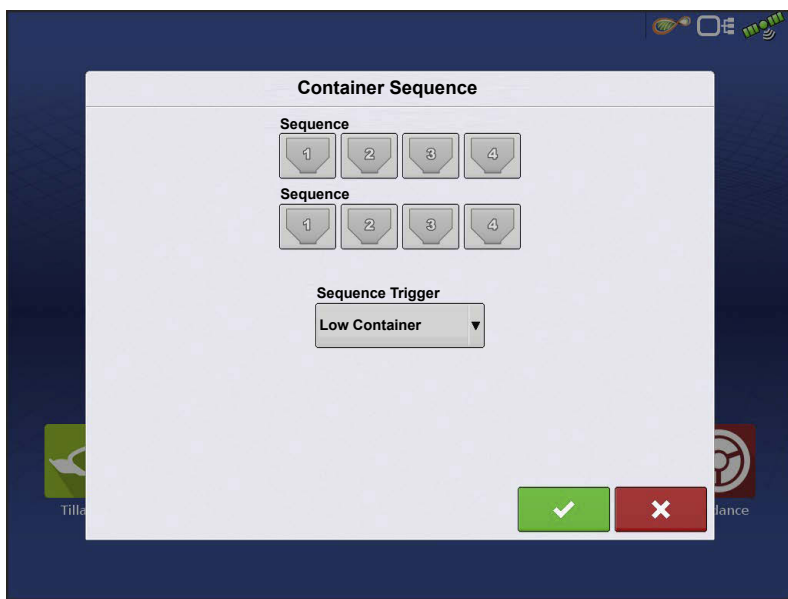

4. Press Container icon to select containers to be sequenced.

**NOTE!** System defaults container sequence to ascending order during initial setup. User can select starting container when configuration loads to the Map Screen.

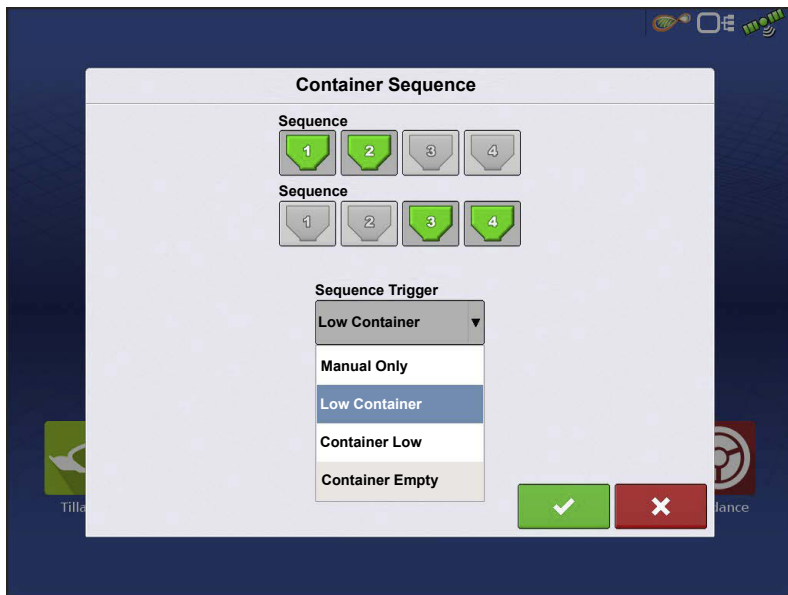

5. Use Sequence Trigger drop-down menu to select container advanced trigger method.

**Manual Advance Only**—Sequence is manually triggered by user pressing container icon on Map screen.

**Low Container Sensor**—Sequence automatically advances to next container in the sequence when low container level sensor is uncovered.

**Container Low**—Sequence automatically advances to next container in the sequence when system reaches low container level alarm countdown set point.

**Container Empty**—Sequence automatically advances to next container in the sequence when container level countdown reaches zero.

Press  to accept and continue and return to the product selection screen.

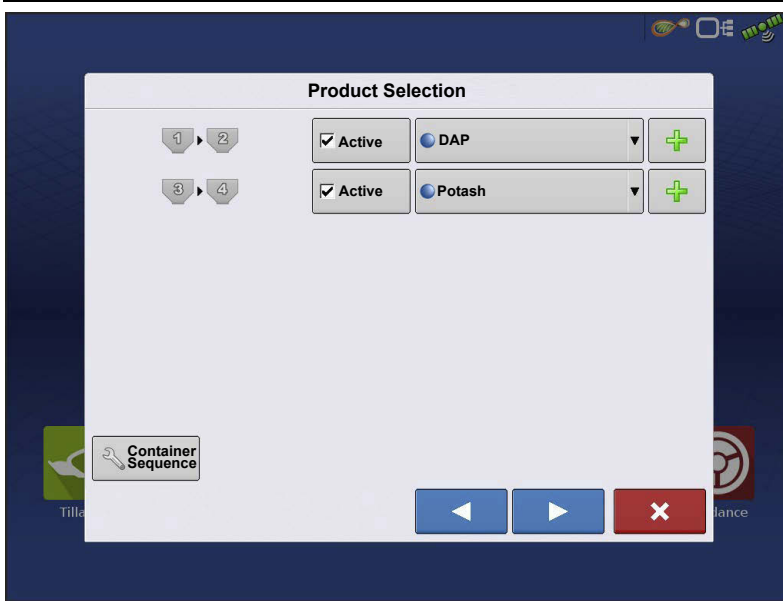

System displays sequenced containers and defaults sequence direction in ascending order.

6. Use drop-down menu to select existing products or press  to add products to active channels. To create new products see [Creating Products on page 817](#).

7. Press  to continue to the Event Selection screen.

8. From the Event Selection screen, Start a new event or select a previous event.

9. Press  to continue to the Options screen. (Event Selection screen will be skipped if a Configuration is being loaded to a field for the first time.)

10. Use the drop-down menu to select controlling units for products to be applied.

11. Press  to accept and continue to Map screen.

## Map Screen

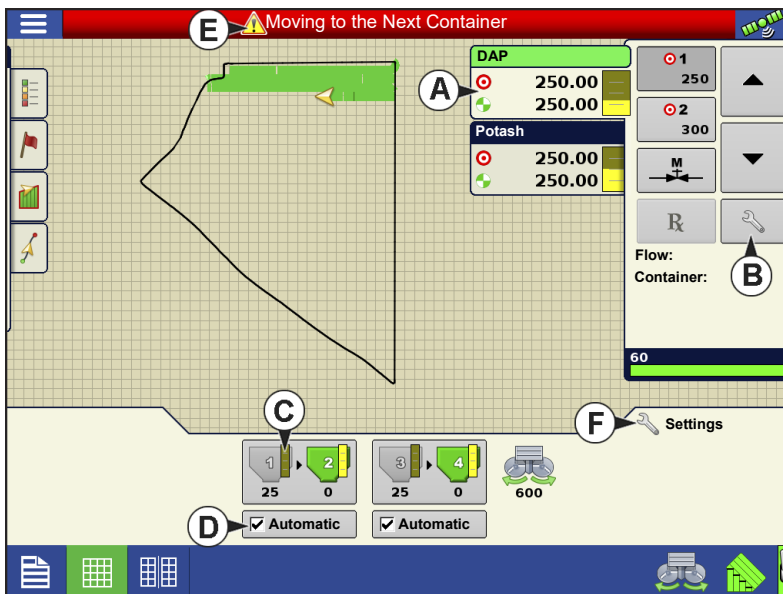

A. Single Rate control display for all containers in a sequence. Container level indicator displays the combined total for all containers in the sequence.

B. Manage individual container level edits for all containers when using container sequencing. (See below)

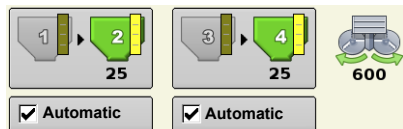

C.Container level indicator displays the independent container level for each application channel in the sequence.

D. Automatic Sequence Enable/Disable button must be checked for Automatic container sequencing to function. If Sequence Trigger is set to Manual Advance Only, Automatic checkbox will not be displayed.

E. Moving to the Next Container Warning alerts user when the user defined Automatic Sequencing Trigger condition has been met and system is advancing to next container in the sequence. This warning is not displayed when manually advancing sequence, system will automatically activate the next designated container in the sequence.

F. Press **Settings** to access standard Spreader Control settings including Static and In-Field calibration routines.

## End of Automatic Container Sequence Warning

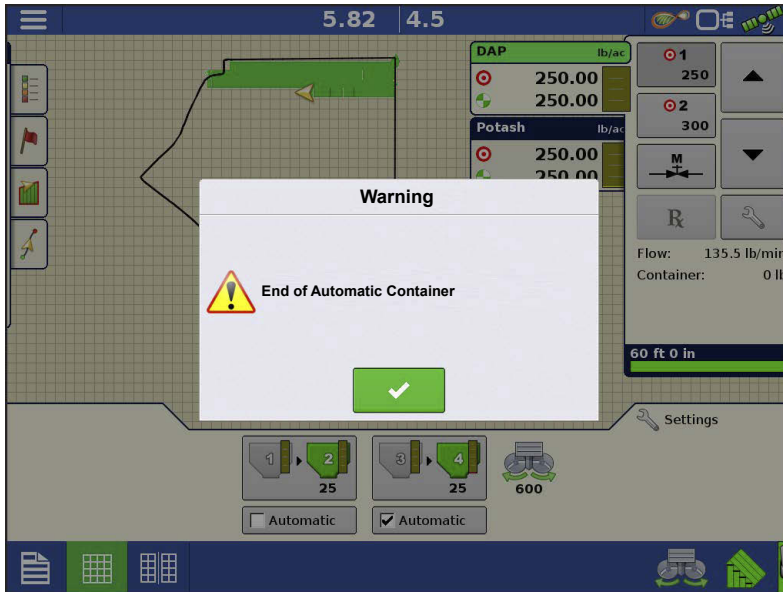

Alerts user the last container in the sequence has met the user defined automatic sequence trigger conditions.

Press  to clear warning dialog.

 **NOTE!:** Control Channel will remain active and continue applying.

- User must manually reset system to the beginning of the sequence.

- The system disables Automatic sequencing. User is required to re-enable Automatic Sequencing for the appropriate container.

## Equipment Settings



OR



## Rate Outside of Field

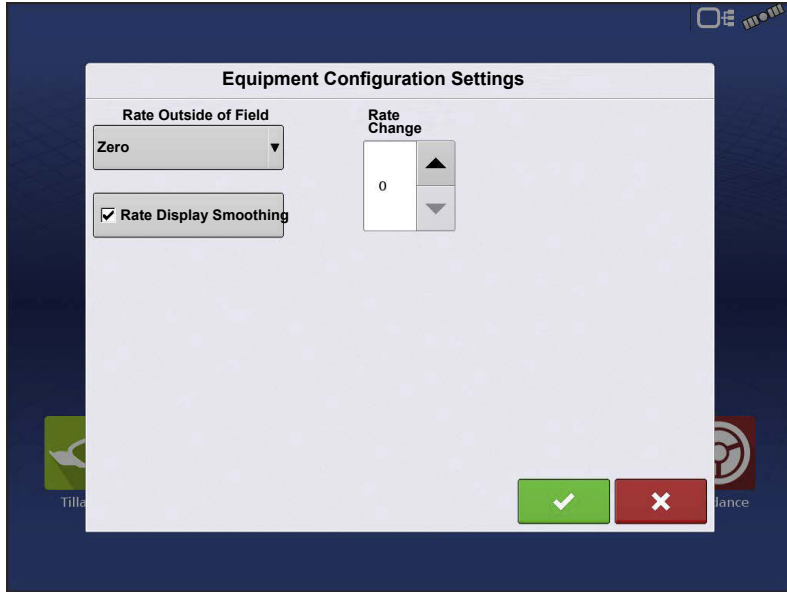

This setting will define how product will be controlled when leaving a field boundary.

- Zero**—This will stop application.
- Last Good**—This will continue application at the last known rate.
- Rx Default**—When using a prescription, this will apply at the Default Rate (or outside of boundary rate) as defined by the prescription

file.

**Rate Display Smoothing**—Determines how the feedback from the control channel rate sensor will be displayed on the map screen. When de-selected, the system will display raw feedback from the rate sensor. When checked, the system will display target rate when the application rate is within 10% of the target rate setting.

**Rate Change Look-Ahead**—This setting compensates for any latency in the control system when changing between different product flow rates during variable rate application. The typical setting range for this is 0-1 seconds. This setting can be thought of as a “look ahead” value when using a variable rate prescription. The display will send the signal to change rates before hitting a transition line so that the applied rate is correct when crossing into the new management zone.

## Auxiliary Input



OR



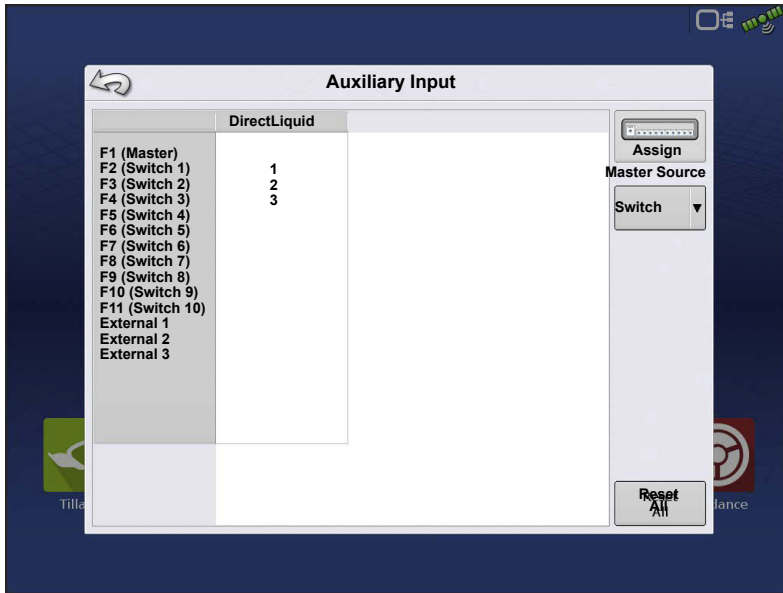

DirectCommand applications default boom sections to the switchbox in order, starting with switch 1. From the Auxiliary Input screen, the operator can customize the switches to the boom sections, if desired.

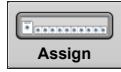
1. Press  .
2. Highlight the desired switch to assign a function to it.

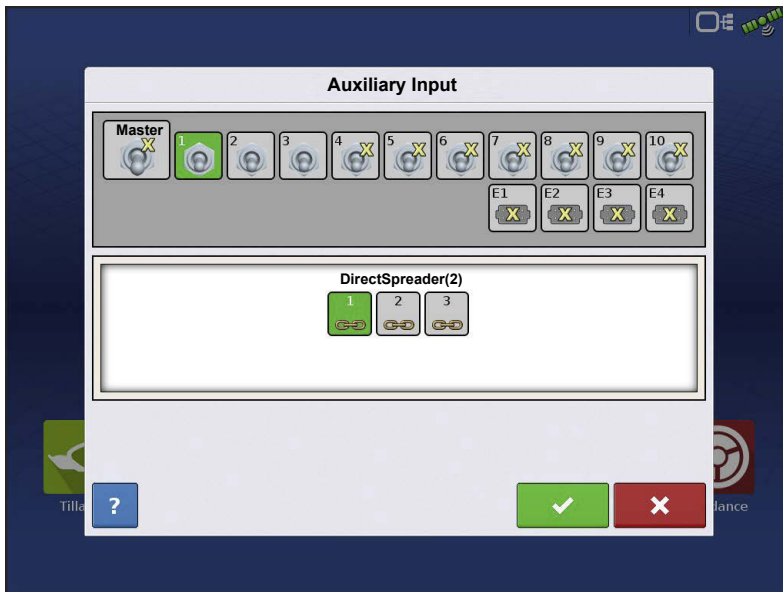

3. Select appropriate function(s) (bin channels for this operation) to assign to the desired switch. Chain icons within each function will "link" once pressed to indicate they are assigned. If a function has a "broken link" then it is not assigned. If a switch has a "X" then it is not assigned to a function.

Press the  to save the setup.

 **NOTE!:** Even if no specific

functions are assigned to the Master switch, the Master switch will still serve as the total system on/off switch.



## Controller Settings

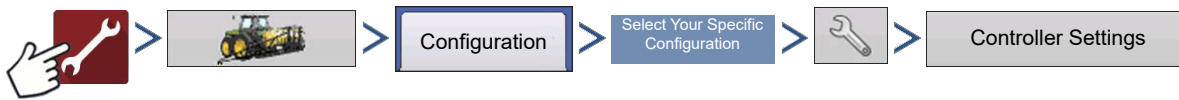

OR



Controller Settings screen appears, with each channel’s settings shown on its own tab.

The settings shown at this screen vary, depending upon whether your spreader uses a PWM Control Valve or a Servo Control Valve. Use the Control Valve Configuration drop-down menu to choose the appropriate configuration for your machine.

Spinner settings are accessed and adjusted in a dedicated tab. The Spinner Tab appears behind the channel tabs. The Spinner Tab is where Fan Speed settings are shown.

## Spreader Control: PWM Control Valve

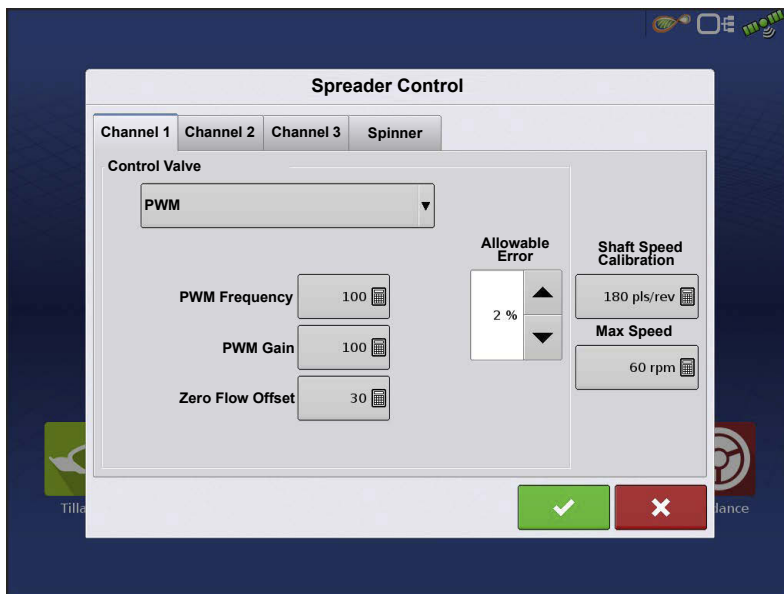

• **PWM Frequency**—The frequency that the PWM control valve is pulsed at. Settings can be found from the manufacturer of the valve. Typical settings range from 100-125 Hz. The default setting is 100.

• **PWM Gain**—Determines how aggressively the control valve responds when making rate adjustments. The higher the value the more aggressive the system response

is. The default setting is 100.

- **Zero Flow Offset**—Represents the maximum duty cycle that is sent to the control valve without producing any hydraulic flow from the PWM valve. Using too high of a Zero RPM

---

Offset value can cause the conveyor to not properly shut off. See the PWM valve manufacturer information for recommended settings. The default setting is 30.

- **Allowable Error**—Determines the percent of error that is allowed prior to the product control system making any flow rate changes. 2% - 3% is the normal dead band setting range.
  - Too low of a setting value can cause the product control system to continually hunt for the target application rate.
  - Too high of a setting will cause excessive product application error.
- **Shaft Speed Calibration**—Calibration number representing the pulses that equal one revolution of the rate control metering system.
- **Max Speed**—The Maximum Conveyor Speed Setting determines the maximum RPM of the conveyor that controls product distribution to the application point.

## Spreader Control: Servo Control Valve

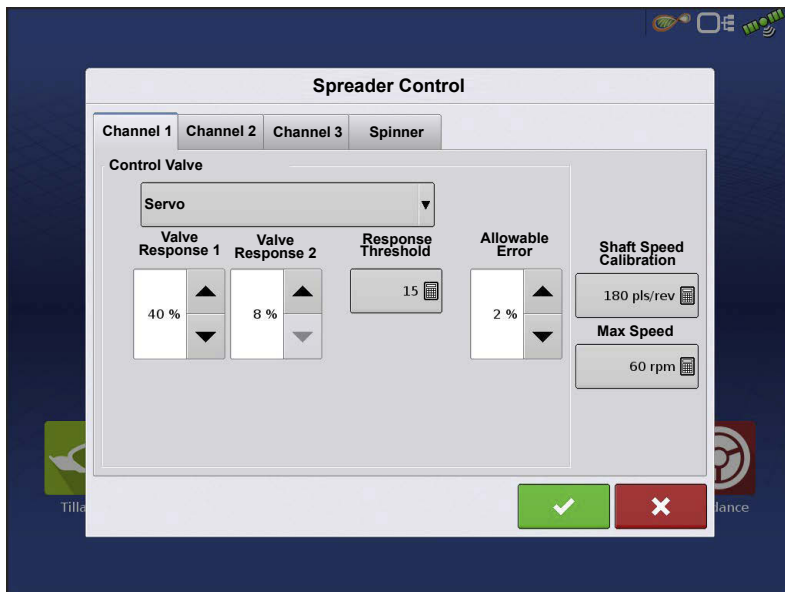

• **Valve Response 1**—Determines the speed of the servo valve when product control error exceeds the Response Threshold setting. Represents the fast speed of the servo valve. Decreasing the value will cause the servo valve to run slower. The default setting is 40%.

• **Valve Response 2**—Determines the speed of the servo valve when product control error is less than the Response Threshold setting. Represents the

slow speed of the servo valve. Decreasing the value will cause the servo valve to run slower. The default setting is 8%.

- **Response Threshold**—Determines where the control channel switches between using Valve Response 1 and Valve Response 2 speed setting. Leaving all other valve control settings at the default value and making a small adjustment to this setting is usually all that is required to fine-tune system performance. The default setting is 15.

- Decreasing this value will have the overall effect of speeding up servo valve response.
- Increasing this value will have the overall effect of slowing servo valve response.
- **Allowable Error**—Determines the percent of error that is allowed prior to the product control system making any flow rate changes. 2% - 3% is the normal dead band setting range.
  - Too low of a setting value can cause the product control system to continually hunt for the target application rate.
  - Too high of a setting will cause excessive product application error.
- **Shaft Speed Calibration**—Calibration number representing the pulses that equal one revolution of the rate control metering system.
- **Max Speed**—The Maximum Conveyor Speed setting determines the maximum RPM of the conveyor that controls product distribution to the application point.

## Spreader Control: Spinner Tab

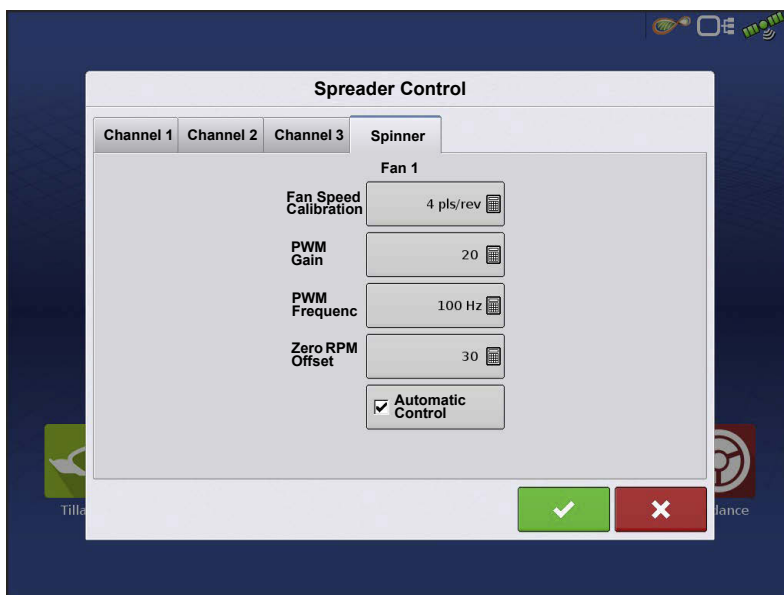

To view Fan Speed Calibration settings, press the Spinner Tab.

Operators with Spinner Spreaders that use PWM valves will see additional active settings.

•**Fan Speed Calibration**—The number of pulses that are generated by the sensor during one revolution of the spinner dish. The default setting is 4.

•**PWM Gain**—Determines how aggressively the control valve responds when making spinner speed adjustments. The higher the value the more aggressive the system response is. The default setting is 20.

- **PWM Frequency**—The frequency that the PWM control valve is pulsed at. Settings can be found from the manufacturer of the valve. Typical settings range from 100-125 Hz. The default setting is 100.

- **Zero RPM Offset**—Represents the maximum duty cycle that is sent to the control valve without producing any hydraulic flow from the PWM valve. Using too high of a Zero RPM Offset value can cause the spinner system to not properly shut off. The default setting is 30.



**NOTE!:** See the PWM valve manufacturer information for recommended settings.

- **Automatic Control**—Checking this box enables closed loop spinner control.

## Stepper Spreader Control

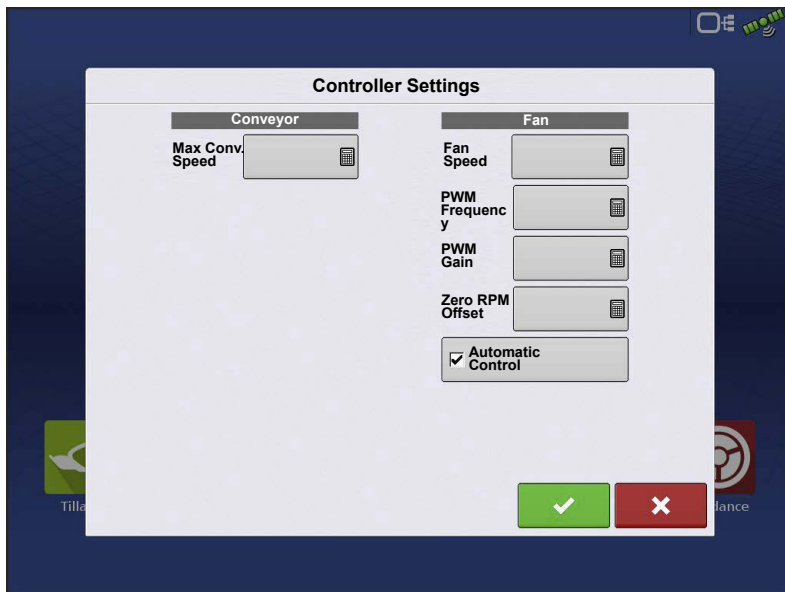

• **Max Conv. Speed**—The Maximum Conveyor Speed setting determines the maximum RPM of the conveyor that controls product distribution to the application point.

• **Fan Speed Calibration**—The number of pulses that are generated by the sensor during one revolution of the spinner dish. The default setting is 4.

• **PWM Frequency**—The frequency

that the PWM control valve is pulsed at. Settings can be found from the manufacturer of the valve. Typical settings range from 100-125 Hz. The default setting is 100.

- **PWM Gain**—Determines how aggressively the control valve responds when making spinner speed adjustments. The higher the value the more aggressive the system response is. The default setting is 20.
- **Zero RPM Offset**—Represents the maximum duty cycle that is sent to the control valve without producing any hydraulic flow from the PWM valve. Using too high of a Zero RPM Offset value can cause the spinner system to not properly shut off. The default setting is 30.



**NOTE!:** See the PWM valve manufacturer information for recommended settings.

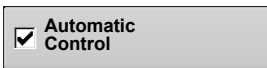

- **Automatic Control**—Checking this box enables closed loop spinner control.

## Automatic Spinner Control



Turn Spinners on/off by pressing the Spinner Icon located in the Task Bar. After pressing the Spinner Icon, a warning will appear alerting user the spinners will turn on and to remain clear of equipment.



Press  to turn spinners on and clear warning dialogue. Press  to keep spinners from running and clear warning dialog.

## Run Time Operations—Spreader Control

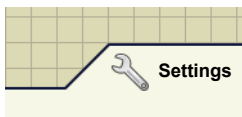

During Run Time Operations, Spinner Spreader operators can press the **Settings** button to open the Spreader Control screen. At this screen, you can adjust Spread Width, Spinner Speed, Product Density and other settings.

- Each of these settings described below must be set for each individual Product Channel (bin).
- Changed settings do not take effect until verified.
- The **Spread Width**, **Spinner Speed**, **Product Density**, **Feed Gate 1 Opening** and the **Conveyor 1 Rate** are all stored with each combination of product and control channel.

## Spreader Control screen

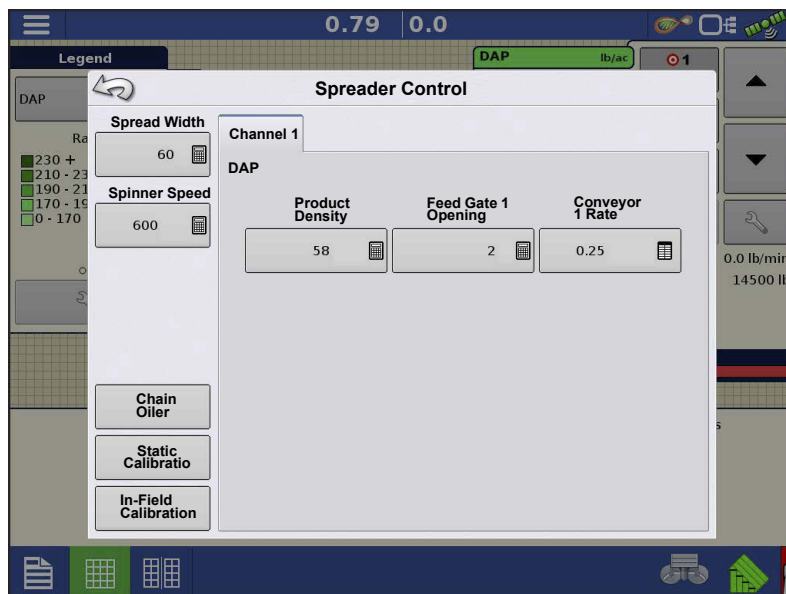

•**Spread Width**—Press to edit the value.

 **NOTE!** Note: If Spread Width is grayed out and unable to edit, this indicates a guidance pattern is loaded. In order to Edit Spread Width, user must Reset the guidance pattern first.

•**Spinner Speed**—The spinner speed required for accurate product placement in relation to the spread

width setting.

- 
- The spinner speed is controlled automatically based upon this setting when the system uses an optional PWM spinner speed control valve.
  - To accurately determine Spinner Speed settings you should perform a spread pattern catch test.
  - **Product Density**—This density value (shown in pounds per cubic foot, or lb./ft.3), is stored with each product. Press  to edit if needed.



**NOTE!** For proper machine performance and accuracy. Product Density should be measured for every application load.

- **Feed Gate 1 Opening**—Represents the Feed Gate opening for Conveyor 1. Measure the depth of product on the conveyor to ensure accurate feed gate setting value.
- **Conveyor 1 Rate**—This setting represents the volume of product dispensed by one revolution of the conveyor drive shaft (cubic foot per revolution, or ft<sup>3</sup>/rev.) This number is shown with the assumption that the conveyor shaft has a 1-inch gate opening. (When the display is in Metric units, this number is shown with the assumption that the conveyor shaft has a 2.54 cm gate opening.) This conveyor rate remains constant, regardless of the height of the feed gate opening.



**ATTENTION!** You must either manually enter conveyor rate value or perform a CFR calibration routine for each product and channel combination, otherwise misapplication will occur.

## Conveyor Rate Look-Up

A pop-up screen will display a warning when a product is assigned to a container or bin for the first time and has not been calibrated. The warning prompts the operator to review product density and conveyor rate settings.

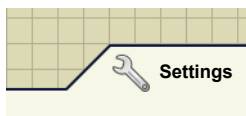

Conveyor rates for previously applied products can be found by first pressing the **Settings** button which opens the Spreader Control screen.



## Spreader Control

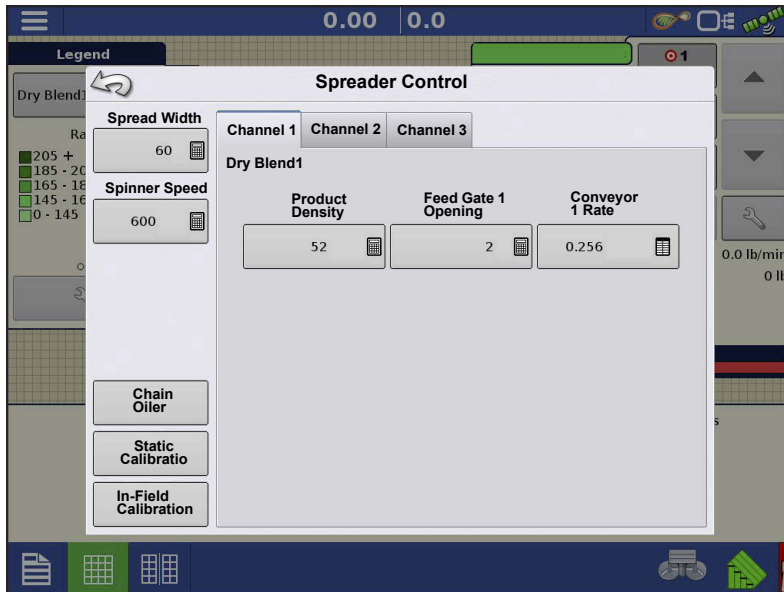

The Spreader Control screen has a tab for each control channel/product being applied. Select the desired channel and press the **Conveyor Rate** button.

**WARNING!:** For proper machine performance and accuracy, Product Density should be measured for every application load.

## Conveyor Rate

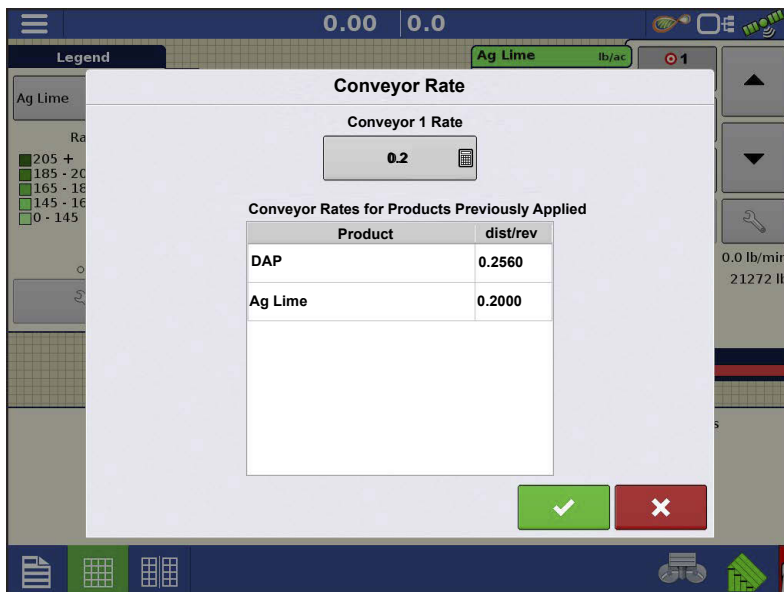

The **Conveyor Rate** button opens a setup screen where the conveyor rate can be input, and a table of previously applied products and conveyor rates is shown.

Highlight desired product by pressing it and press  to input desired conveyor rate.

Press  to accept the new conveyor rate and return to the

Spreader Control window.

---

## Spreader Control: Routine Operations

The Spreader Control screen has three buttons, Chain Oiler, Static Calibration and In-Field Calibration, which are described below and on the following pages.

### Spreader Control: Chain Oiler

If you are using a Chain Oiler, you can automatically perform a chain oiling routine by pressing the Chain Oiler button on the Spreader Control screen and following the steps below.

 **NOTE!** Perform a chain oiling routine daily.

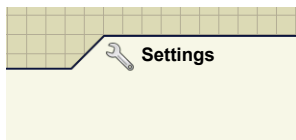

1. **Press Settings button**—To begin, press the Settings button to open the Spreader Control screen. At the Spreader Control screen, press the Chain Oiler button.

2. **Acknowledge the first warning**—Manually disable or shut off the spinner hydraulic circuit.
3. **Enter a Routine Duration**—Enter the routine time that it takes to turn the conveyor one revolution.
4. **Press Start**—Press the Start button, and when the routine is finished press .
5. **Acknowledge the second warning**—Return the spinner hydraulic control to a field-ready condition.

### Spreader Control: Static Calibration

You must perform a conveyor discharge calibration for each granular product control channel (bin) for the equipment configuration. This process is outlined below and on the following page. The static calibration procedure is performed before applying in field conditions.

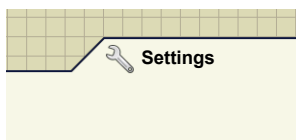





1. To begin, press the **Settings** button on the Map screen. The Spreader Control screen opens.

2. Press the **Static Calibration** button to start the Static Conveyor Rate calibration routine.

3. **Disable Spinner Hydraulic Circuit**—The system will present a warning to disable the spinner hydraulic circuit. Press  after the hydraulic circuit is disabled.



**DANGER!** Manually disable or shut off the spinner hydraulic circuit. If the spinner runs unexpectedly, injury could occur.

4. Select **Conveyor** to Calibrate
5. **Enter Dispense Amount**—Enter the desired target amount of product to dispense (the recommended amount is 500 pounds or 250 kilograms). Press  to continue.
6. **Start Dispensing Product**—Press the **Start** button to begin dispensing the product. Dispensed product will need to be caught during calibration routine and weighed afterwards.
7. **Product Dispensing**—The conveyor will stop when the system perceives the target amount of product has been dispensed. The **Stop** button can be pressed at any time to manually shut off the conveyor.
8. **Product Dispensing Stops**—On the screen shown after dispensing the display's target amount, value can be reset and the process started again for a larger sample size, if desired. Press  to continue.
9. **Enter Actual Dispense Amount**—Enter the actual weight of the product dispensed. Press  to continue.
10. **Finish Calibration**—A screen displays, stating Calibration Complete and underneath is shown the newly-calibrated conveyor rate.
  - Press  to exit the calibration without saving the value.
  - Press **Repeat Calibration** to begin the process again.
  - Press  to save the value and exit the calibration routine.



**DANGER!** Make sure the spinner is free of material before restarting the spinner hydraulic circuit.



11. A warning will appear when exiting the calibration wizard, instructing you to return the spinner control hydraulic circuit to a field-ready condition.

## Spreader Control: In-Field Calibration

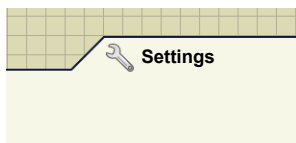
The In-Field Conveyor Calibration procedure performs an automated routine to adjust the calibration number for the selected spinner bin. This calibration is performed if there is a difference between the amount of product logged as compared to what was actually applied.



1. To begin, press the **Settings** button on the Map screen. The Spreader Control screen opens. Press the **In-Field Calibration** button on the Spreader Control screen. The In-Field Conveyor Rate Calibration Wizard appears.

2. **Select Conveyor to Calibrate**—Select the channel to calibrate, and press  to continue.
3. **Enter Actual Weight**—The Accumulated Weight is shown in the top portion of the window. Press  to enter the Actual Weight, and press  to continue.



**NOTE!** Start a new Region to reset the Accumulated Weight to 0 lbs.

4. **Calibration Complete**—A message appears, stating that your calibration is complete, and showing the CFR amount in cubic feet per revolution. Press  to finish.

## Troubleshooting DirectCommand Granular Applications

**Problem:** Run screen Granular channel(s) green light spreader indicator will not turn on.

**Solution:**

1. Make sure ground speed is registered a value greater than zero on the display.
2. Verify a target rate greater than zero is entered into the display.
3. Check the switch status found on the Run screen under CAN and Auxiliary Input Diagnostics. As the master switch is turned on and off, the Auxiliary Input Diagnostics window should change from black to green (if they do not, then refer to the installation instructions to verify switch connections).
4. Check high current connection into the Granular Control Module.

**Problem:** Master switch will not turn on when the foot pedal is on.

**Solution:** Make sure the Master Source Input is set to “External 2” under the Auxiliary Input settings.

**Problem:** AutoSwath turns on the conveyor or drive too fast or too slow.

**Solution:**

1. Check GPS offsets in the vehicle setup to verify all of the measurements are correct.

- 
2. For pulled implements - Verify implement offsets are appropriate for the spreader.
  3. Adjust the turn on look-ahead and turn off look-ahead to fine-tune Automatic Swath Control performance.

**Problem:** AutoSwath feature is not shown.

**Solution:** The display must have the AutoSwath feature password-unlocked before the feature is available to the operator.

**Problem:** Conveyor drive turns on when outside of the boundary.

**Solution:**

1. Make sure the Rate Outside of Field option is set to zero under the active configuration settings.
2. Make sure the Outside Boundary Option is set to Turn Section Off under the Automatic Swath Control options.
3. Make sure there is not a gap between the boundary and the first pass of the headlands.

**Problem:** AutoSwath is checked on, but the spreader will not turn on.

**Solution:**

1. Make sure the ground speed is registering a value greater than zero on the display and not in covered area.
2. Make sure the applicator is inside of the field boundary.
3. Make sure there is a target rate greater than 0.
4. Verify the Master Switch icon is indicating On (green) and Off (red) appropriately.

**Problem:** Conveyor turns off in the middle of the pass.

**Solution:**

1. Check the display firmware and module firmware to see if they are running the latest version.
2. Make sure the ground speed does not go to 0.
3. Make sure the GPS is not losing the differential source.

**Problem:** Total Applied does not match Actual Weight Applied.

**Solution:**

- 
1. Make sure the shaft speed pls/rev are set correctly in the Controller Settings.
  2. Make sure the controlling product is set to the correct units.
  3. Review Static or In-Field calibration procedures to ensure process was done appropriately.

**Problem:** Rate not responding.

**Solution:**

1. Make sure there is a ground speed registering on the display.
2. Make sure the shaft speed pls/rev are set correctly in the Controller Settings.



**NOTE!:** You must make sure to account for sprocket ratios if chain driven..

---

$$\frac{\text{Driven Teeth}}{\text{Drive Teeth}} \times \text{Rate Sensor Pulses} = \text{True Pulses}$$

3. The CFR number may need to be adjusted.
4. Use Manual Valve control to see if the control valve will open or close.

## Troubleshooting Serial Control Applications

**Problem:** Rate changes on the display, but not on the controlled console.

**Solution:**

1. Verify the current firmware is running on the display and Application Rate module.
2. Check the settings specific to your controlled console.
3. Check cabling and all connections.
4. Disconnect the serial connection and determine if the controller is functioning properly without the display.

**Problem:** The display rate and serial-controlled rate do not match.

**Solution:**

1. Verify the current firmware is running on the display and Application Rate Module.
2. Check to make sure the nominal rate in the display matches the nominal rate in the serial-controlled console.

DirectCommand™ for Strip-Till applicators monitors bin level and fan speed sensors, maintains an accurate application rate and supports multiple product prescription rate control for up to three granular products. The Strip Till module supports PWM and Motorized Servo valves, as well as Electric Linear Actuators/Meter Clutches. System can be configured for Strip Till fertilizer application or Air Seeder (Planting) control. To create an Air Seeder (Planting) configuration continue to [Create Configuration](#) on [page 856](#).

## Load Configuration



Press the Application App from the home screen. This will take you through the steps needed to load a configuration.

## Map View

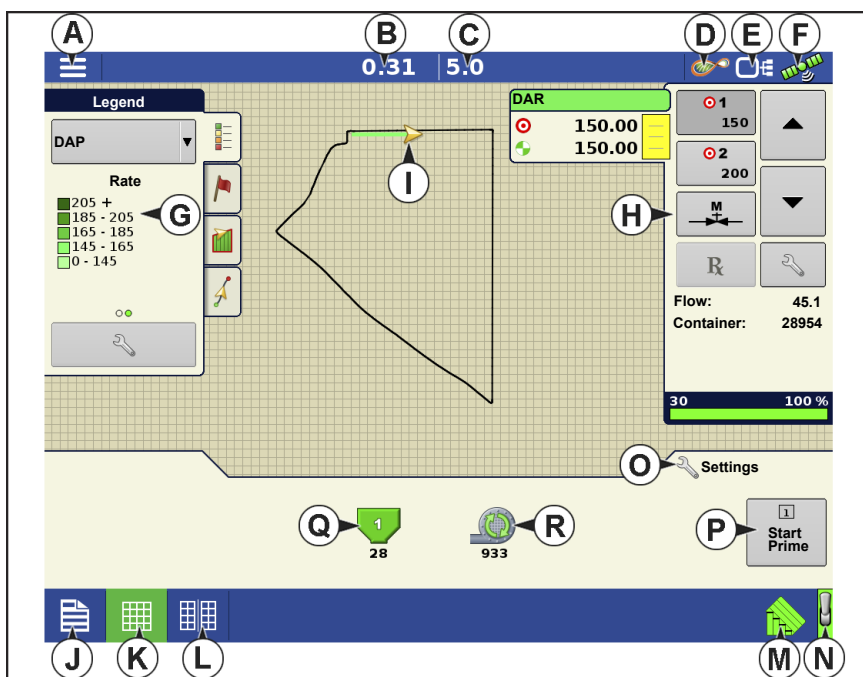

Once a configuration has been completed. The Map view screen appears.

A.Menu button

B.Total Logged Field Area

C.Ground Speed

D.AgFiniti® Status

E.Diagnostics

F.GPS Signal Indicator

G.Display Legend

H.Product Control toolbox

I.Vehicle Icon

J.Event Summary

K.Map View

L.Split screen

M.AutoSwath™

N. Master Switch Status

- O. Settings
- P. Start Prime button
- Q. Bin Level
- R. Fan Speed



**NOTE!:** Pressing the Map View button will cycle between the available Map Screen views, and the appearance of the Map View button changes.

## Product Control Toolbox

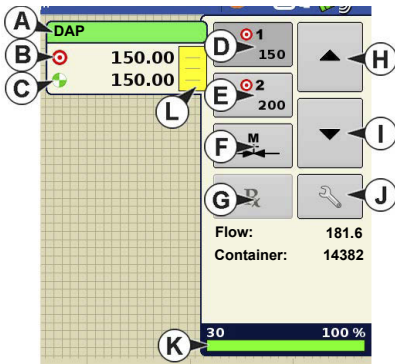

During DirectCommand Run Time operations, the Product Tab(s) are shown in the upper right-hand side of the Map screen. Press the Product Tab(s), and an extended view shows the Rate buttons, Manual Valve Control button, Prescription button, Rate Increase and Decrease arrows, and the Rate Setup button.

- |                         |                             |
|-------------------------|-----------------------------|
| A. Product              | G. Prescription button      |
| B. Target Rate          | H. Rate Increase arrow      |
| C. Actual Rate          | I. Rate Decrease arrow      |
| D. Rate 1 button        | J. Rate Setup button        |
| E. Rate 2 button        | K. Section Status Indicator |
| F. Manual Valve Control | L. Container Level          |

**Target Rate**—The Target Rate is desired application rate.



**NOTE!:** In some conditions, the Target Rate may increment more quickly than the Actual Rate.

**Actual Rate**—The Flow Sensor returns the actual rate being applied.



**NOTE!:** In some conditions, the Actual Rate may increment slower than the Target Rate, or its numeric values may vary before matching the Target Rate.

**Container Level**—The Container Level shows the amount of product in the container.



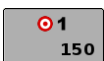

**Rate 1 and Rate 2 buttons**—The Rate 1 and Rate 2 settings represent preset application rates that allow operators to quickly change between desired target rates for each individual product.



**Manual Valve Control button** — The Manual Valve Control button allows operators to specify the position of the control valve. Operators use this option to prime the system before application or clean out the equipment at the end of the day.

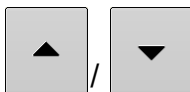

**Rate Increase and Decrease Arrows** — allow Product Application Rate to be changed according to the Target Rate Increment. In using manual valve control, the increase and decrease buttons allow the position of the control valve to be defined by the operator.

**Prescription button**— 

**Rate Setup button**— 

## Rate Control Settings

Adjust the Rate 1 and Rate 2 settings shown at the Product Control Toolbox on the Map screen, as well as import application product prescriptions. To access the Rate Control Settings screen,

press  on the Product Control Toolbox. The Rate Control Settings screen appears.

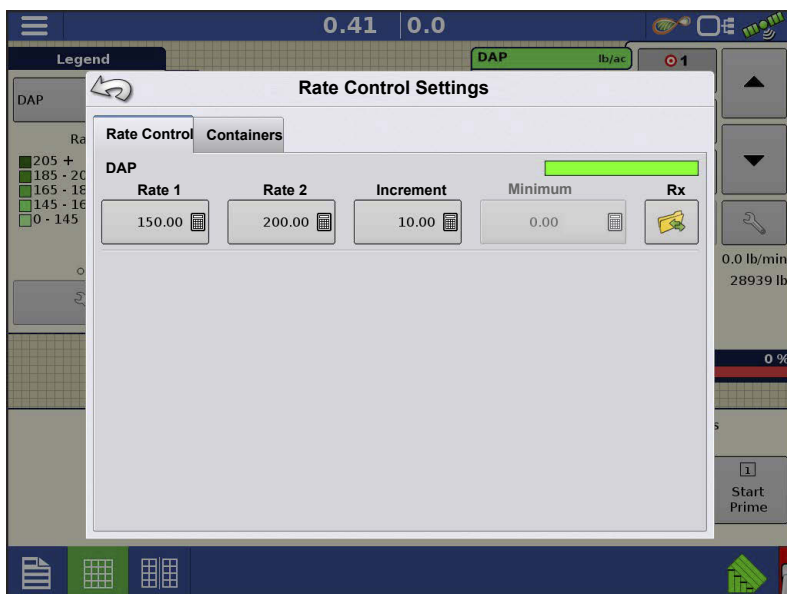

**Rate 1 and Rate 2** — The Rate 1 and Rate 2 settings represent preset application rates that allow operators to quickly change between desired target rates for each individual product. Press  to enter the desired amount.

**Increment** — The Increment button allows operators to specify the increase or decrease amounts for a

specified rate by using  /  on the Product Control Toolbox. Press  to enter the desired increment.

**Prescription** — To load a map-based prescription file, press the Prescription button. Refer to [Loading Prescriptions on page 848](#) for further detail.

**Minimum Flow** — (Used for DirectCommand Liquid Applications only). This setting is used to maintain a consistent spray pattern. The display will not allow flow to drop below the entered setting. Set to flow at the lowest operating pressure for the selected spray tips with all sections on. When spraying with one or more boom sections off, the system automatically reduces the minimum flow setting according to the reduced spray width. To adjust this setting, press  and enter the desired numeric value.

## Container Level Settings

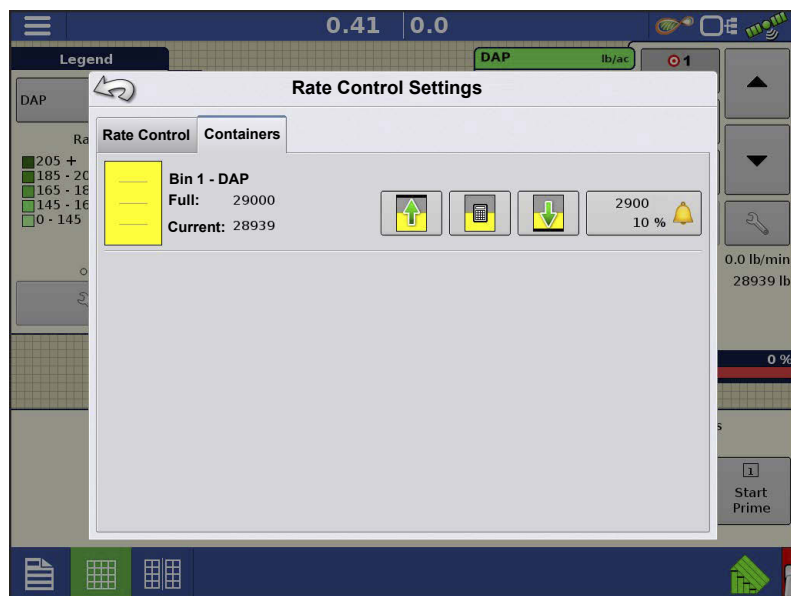

When filling or emptying container, use the Container Level portion of the Rate Control Settings screen to update the amount of product in the containers.

 **Tank Fill** — The Tank Fill button increases the container level logged in the display to the user-defined maximum volume (specified in the Container Setup Wizard).



**Tank Empty** — The Tank Empty button decreases the container level logged in the display to zero.



**Tank Partial Fill** — The Tank Partial Fill button increases the container level logged in the display to specific amount that you specify by pressing calculator icon. Pressing the Partial Fill button summons the Adjust Container Amount screen.

## Adjust Container Amount

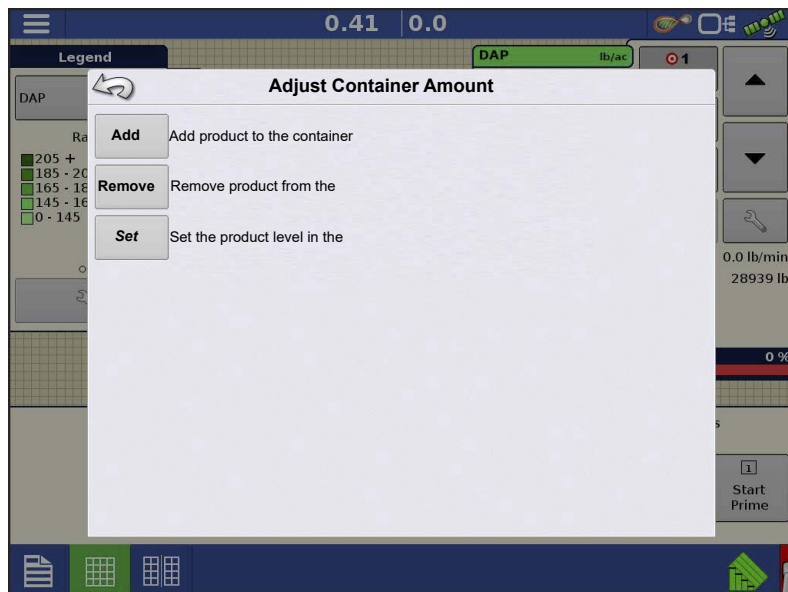

**Add** —Adds product to the container.

**Remove** —Removes product from the container.

**Set** —Sets the product level in the container.

## Tank Alarms

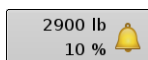

The Container Alarm button, which appears on the right of the Container Level portion of the Rate screen, displays the capacity of your tank as well as the percentage at which the Low Container Level warning will sound. To adjust these settings, press the button and the Container Alarm screen appears.



If you wish to adjust your container level warnings, use the following buttons on the right-hand side of the Container Alarm screen to make these adjustments.

The **Percentage (%)** button sets the warning threshold according to the percentage of product left in the tank. In the example above, the threshold is set at 10 percent.

The **Units of Measurement** icon sets the warning threshold according to the amount of product left in the tank. This icon is named according to the container's units of measurement you specified during the Controller configuration procedure.

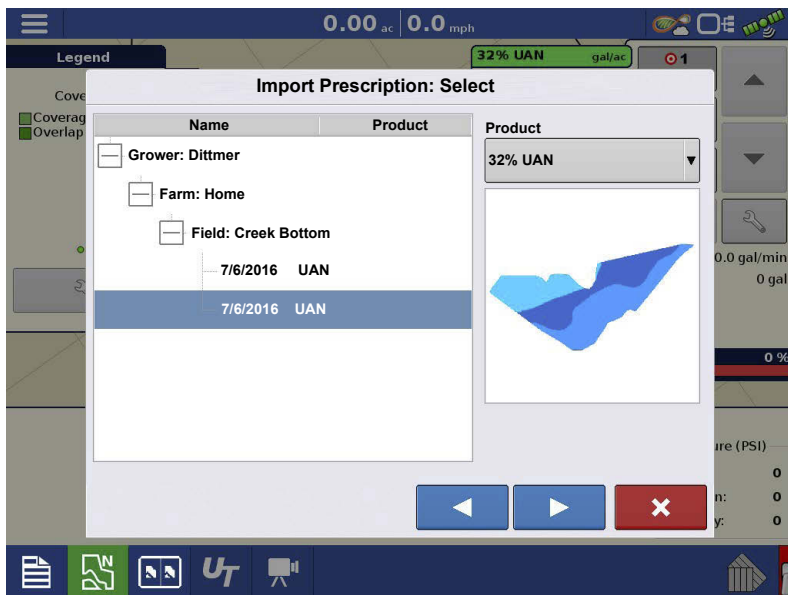

The **Disable Low Container Level** button, which appears as a bell with a red slash across it, disables the Low Container Level warning.

## Loading Prescriptions



1.  Press the Rate Setup button on the Product Control Toolbox.

2. Press the Load Prescription button.

3.  Using an inserted USB or AgFiniti Cloud, search for and highlight the correct .agsetup, .irx, or shape file and press .

4. Select the prescription in the Select Prescription screen, and select the correct controlling product from the Product dropdown box. A preview prescription map is displayed. Press .

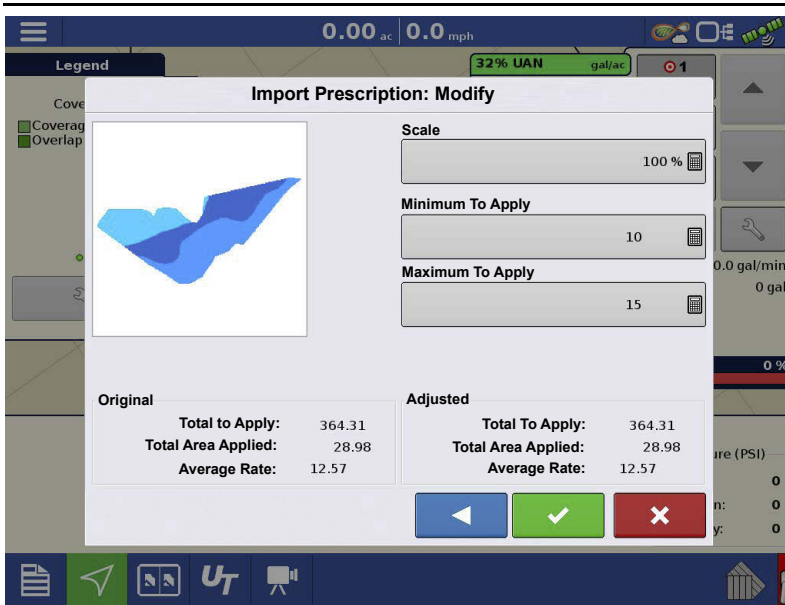

5. In the Modify Prescription Screen the prescription scale, minimum to apply, and maximum to apply can be changed. As the three parameters are changed, the adjusted total to apply and average rate will update accordingly.

6. Press the .

7. After returning to the Mapping Screen, the prescription will appear on

the map while in a North Oriented view.

## Shape File Conversion

What is commonly called a shape file is actually a collection of three different files. All three of the files are required and must be present on the USB drive for the system to use shape file groups for variable rate product application. A single "shape file" can contain recommendation rates for multiple products.

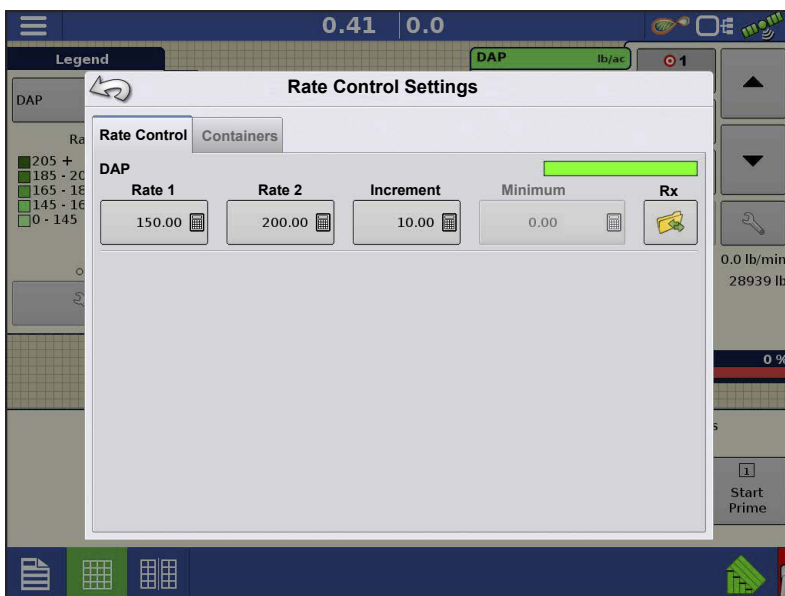



1. To begin, press  on the Product Control Toolbox.

The Rate Control Settings screen appears

2. Press the Load Prescription button.

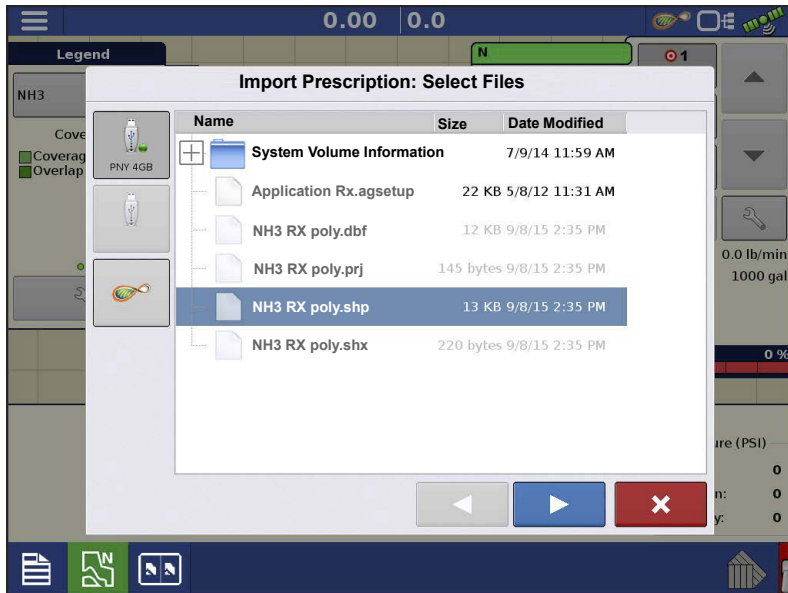



3. The Select File screen appears. Highlight your desired .shp file and press .

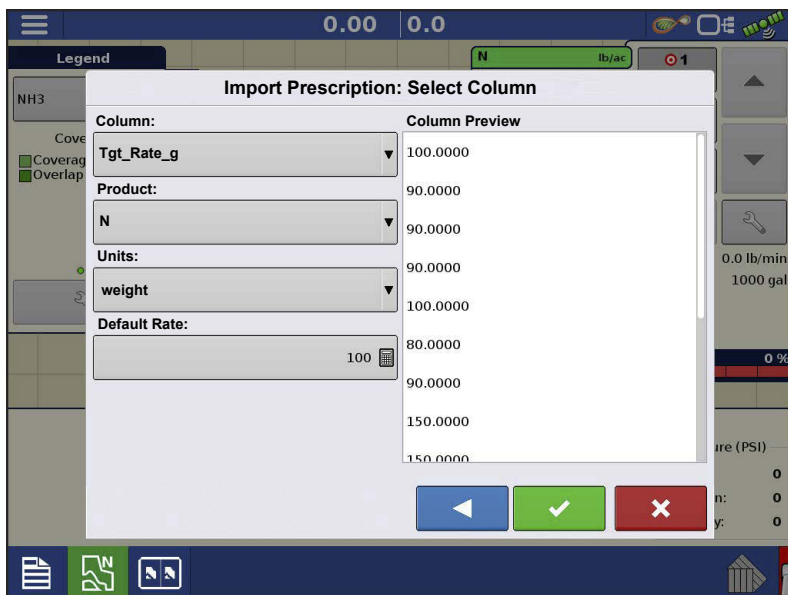

4. **Select Column From Shape File**—

Select the column that contains the product recommendation rate. The list on the right side of the dialog shows sample data from the selected column.

5. **Select Units**—Select the controlling units for product application.

6. **Default Rate Setting**—The system assigns a default rate. Use the on-screen keypad to edit the value if

desired.



**NOTE!:** Select the product and units that the shape file prescription was made for. Selection of the wrong data column or unit will result in misapplication of product.



**ATTENTION!:** The only time the default rate is used by the system during product application is if the Rate Outside of Field selection is set to " Rx default". This setting is located in the Equipment Settings portion of configuration setup. If the Rate Outside of Field selection is set to "Rx default", the default target rate will be used when the vehicle exits the area covered in the prescription map.

## Creating Products

Creating application products and product templates can be completed during initial setup or from the Product Selection screen of the Field Operation Wizard when starting a field operation.

### Creating Single Products

To create a single product, to be added to a product template or to be applied by itself, use the on-screen wizard described in the following steps.



Select:

1. **Product Type**
2. **Product Units**

When selecting the following fertilizers, use the drop-down menu to select the product units:

- Ag Lime
- Pell Lime
- User Defined Lime
- User Defined N-P-K
- User Defined Micronutrient
- Other

3. **EPA Product Number (Optional)**—Check box if product is a Restricted Use Pesticide



---

4. **Manufacturer name if applicable**—Manufacturer name can be added to the drop-down

menu by pressing .

5. **Enter Product Name**

Press  to enter a unique name for the product.

6. Press  to complete product setup or press  to return to Configuration Setup screen without making a change.

Created product should appear under the Application heading located on the Product tab of the Configuration Setup screen.

 **NOTE!:** Some Fertilizer and Carrier product types are predetermined in the display. These product names cannot be edited. Their Manufacturer and EPA Numbers can be edited after the product is created. Examples are: Fertilizer>DAP or Carrier>30% UAN.

## Creating Dry Fertilizer Blends

Dry fertilizer blends are set up using the on-screen wizard described in the following steps.



7. From the Type drop-down menu select Dry Blend

From the Define By drop-down menu select:

- Total amounts - to define blend by amounts going into the bin
- Rate/acre - to define blend by the amounts going on an acre

Press  to continue.

8. From drop-down menu select base units.

Press  to continue.

9. Press  to start the process of adding components to the blend.









**NOTE!:** Any liquid herbicides set up within the system can be added to create an impregnated blend product.

10. Select the desired component from the drop-down menu.



**NOTE!:** More than 7 products can be put part of a Mix/Blend but only 7 or fewer can be active at the same time.

- A new product can be set up at this time by pressing  and following the Product Setup Wizard.
- Press  to add selected product or press  to return to Add Mix/Blend screen without adding a product.

11. Press  to add an additional component.

12. When all components have been added press .



13. Enter Manufacturer name if applicable.

- Manufacturer name can be added to the drop-down menu by pressing 



Represents Product

14. Press  to enter a unique name for the blend.

15. Press  to complete the process of setting up the dry blend or press  to return to Configuration Setup screen without adding a mix.

Created blend should appear under the Application heading located on the Product tab of the Configuration Setup screen.

## Configure Product Mix



1. When using a Dry Fertilizer Blend, the mix contents and amounts are defined in the Configure Product Mix screen available in the Event Setup Wizard, or Product button in the main menu.

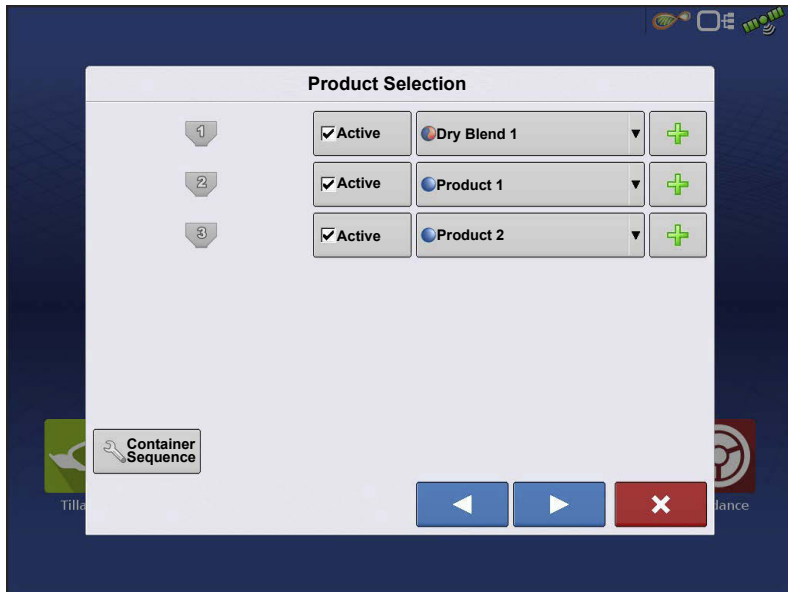

2. Select product from the drop-down list or press  to create a new one.

More than 7 products can be part of a Mix/Blend but 7 or fewer can be active at the same time.

Press  to continue.



3. Configure Product Mix

Product Blends can be adjusted after they are created by:

- a. Activating or de-activating products
- b. Changing rate or total amount of a product
- c. Changing total amount of the product or overall rate of product application

When a Product Blend is setup using

rate/area, the Mix Calculator 

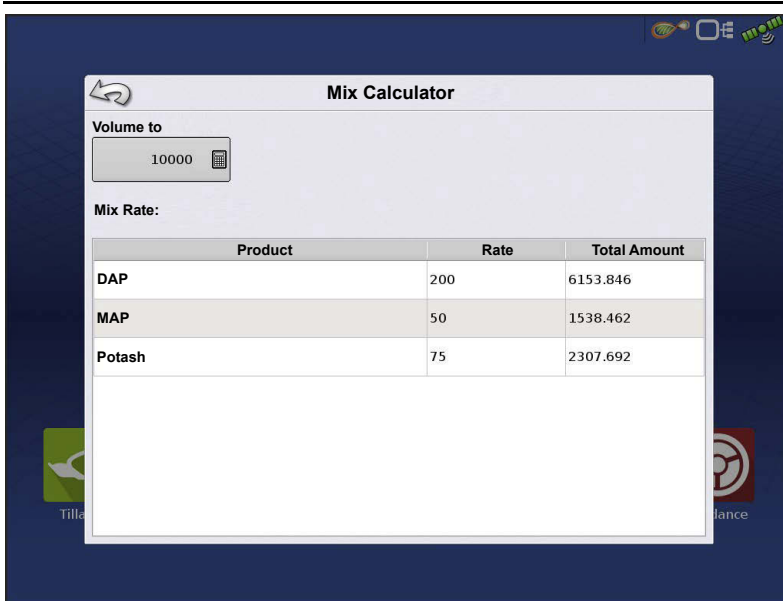

can be used to show how much of

each product to put in the tank when the user enters the desired amount to fill.

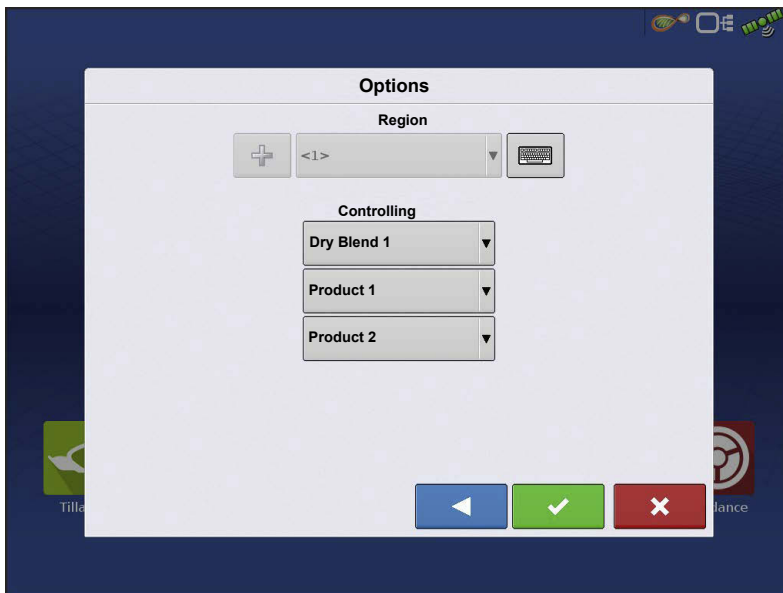

4. Press the Volume to Calculate button and input the total volume. Table will give the user the amount of each product to put in the tank.



5. Select Region from the drop-down menu or press  to name the Region. Verify the Controlling Product for the Product Blend. Press  to load the Event to the Map Screen, or press  return to Home screen without setting up an Event.

---

## Create Configuration

A wizard will guide you through the process of selecting or creating a configuration with application settings.

The configuration can be started in two places:



OR



Your Operating Configuration will then be viewable when you start a new Field Operation with the Application Wizard.

You can also use the **Manage Equipment** button to create or edit specific vehicles and implements.

## Create Air Seeder Configuration

To create a new planting operation configuration, which may also include application equipment:

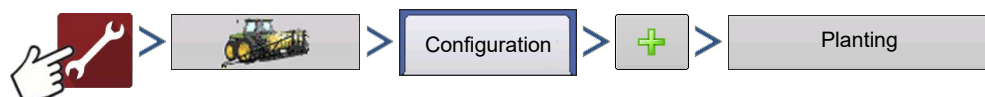

A wizard will guide you through the process of selecting or creating a vehicle, implement and controller. See additional notes below for creating this configuration.

1. Selecting **Planting** as the Operating Configuration
2. Select **Air Seeder** as the Implement Type
3. Select **Granular Strip-Till Control** as the Seed Rate Controller type (name appropriately)
4. In the Application Channel screen, select **Granular Application**
5. Select the **SAME** Rate Controller from the drop-down list that was created in Step 3.

Setup Bins 2 and 3 appropriately as the Application channels. Bin 1 (Channel 1) is automatically assigned as a Seeding Channel and is intentionally unavailable. Channel 1 will only accept crop

types that have units in mass (pounds or kilograms), and is the only channel that is supported for Air Seeding.

## Equipment Settings

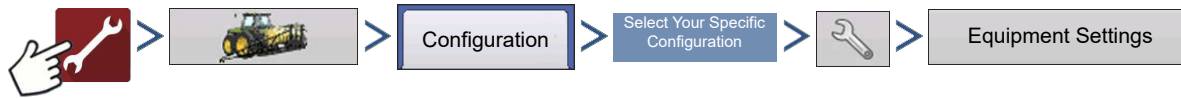

OR

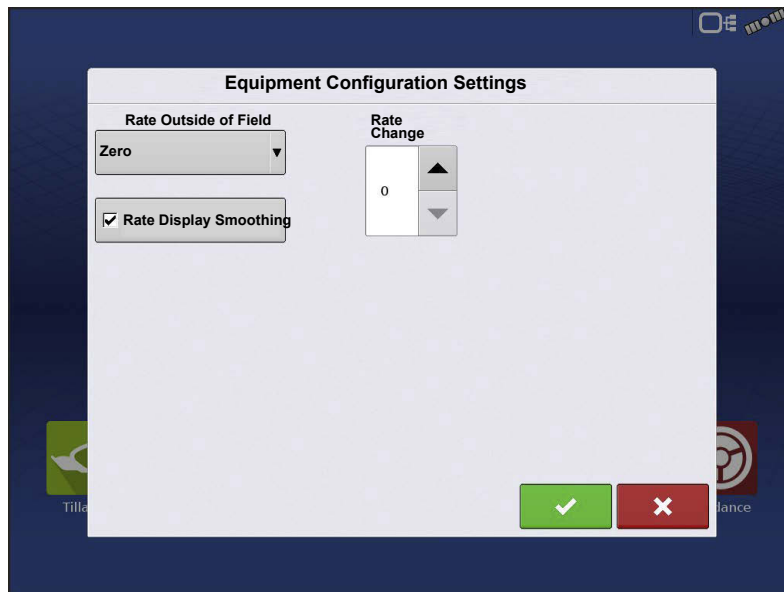

**Rate Outside of Field**—This setting will define how product will be controlled when leaving a field boundary.

- **Zero**—This will stop application.
- **Last Good**—This will continue application at the last known rate.
- **Rx Default**—When using a prescription, this will apply at the Default Rate (or outside of boundary

rate) as defined by the prescription file.

**Rate Display Smoothing**—Determines how the feedback from the control channel rate sensor will be displayed on the map screen. When de-selected, the system will display raw feedback from the rate sensor. When checked, the system will display target rate when the application rate is within 10% of the target rate setting.

**Rate Change Look-Ahead**—This setting compensates for any latency in the control system when changing between different product rates during variable rate application. The typical setting range for this is 0-1 seconds. This setting can be thought of as a “look ahead” value when using a variable rate prescription. The display will send the signal to change rates before hitting a transition line so that the applied rate is correct when crossing into the new management zone.

# Auxiliary Input



OR

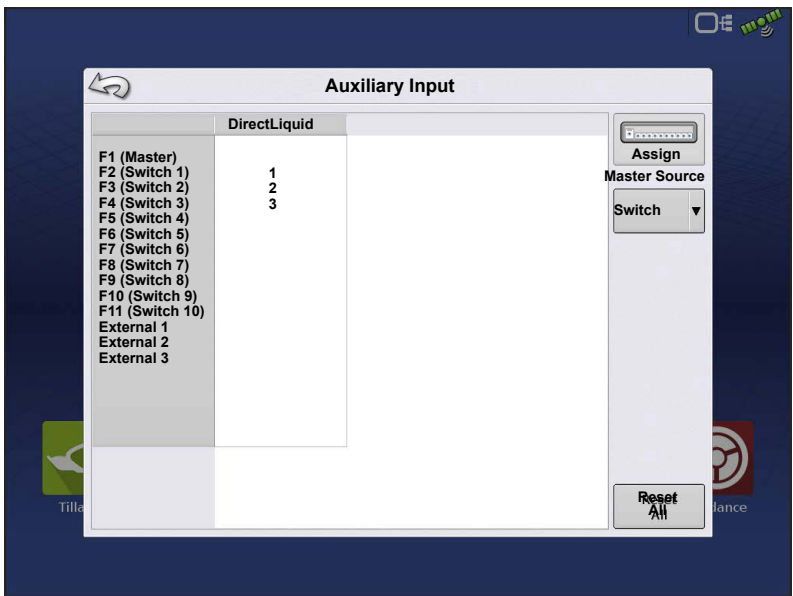

DirectCommand applications default Channels to the switchbox in order, starting with switch 1. From the Auxiliary Input screen, the operator can customize the switches to certain channels, if desired.

1. Press  .

2. Highlight the desired switch to assign a function to it.

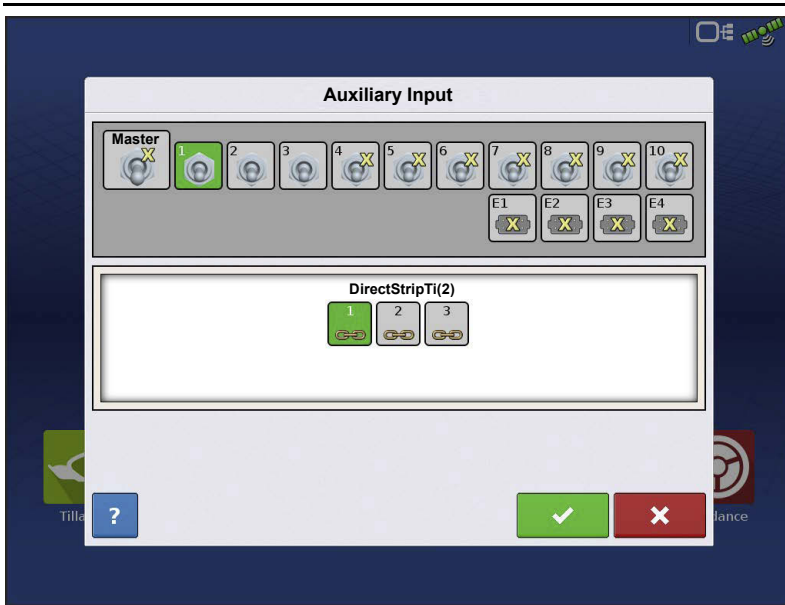

3. Select appropriate function(s) (bins for this operation) to be assign to the desired switch. Chain icons within each function will "link" once pressed to indicate they are assigned. If a function has a "broken link" then it is not assigned. If a switch has a "X" then it is not assigned to a function. Press the  to save the setup.

 **NOTE!:** Even if no specific

functions are assigned to the Master switch, the Master switch will still serve as the total system on/off switch.

## Controller Settings

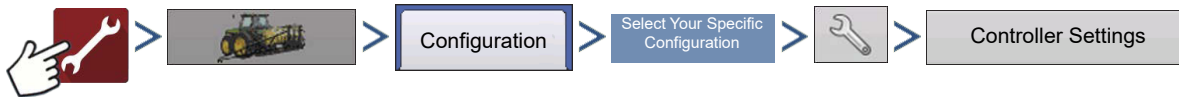

OR

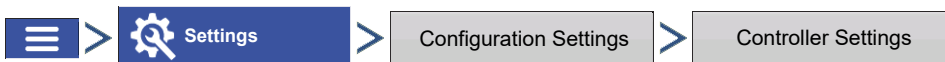

Controller Settings screen appears, with each channel's settings shown on its own tab.

Controller settings viewed at the Strip Till Control window vary depending on Control Valve Configuration type selected including PWM Control Valve, a Servo Control Valve, or a Linear Actuator configuration. Use the Control Valve Configuration drop-down menu to choose the appropriate configuration for your machine. Control valve configuration settings are described in the following section. The Auxiliary Tab allows for adjusting fan settings.

## Strip Till Control: Servo Control Valve

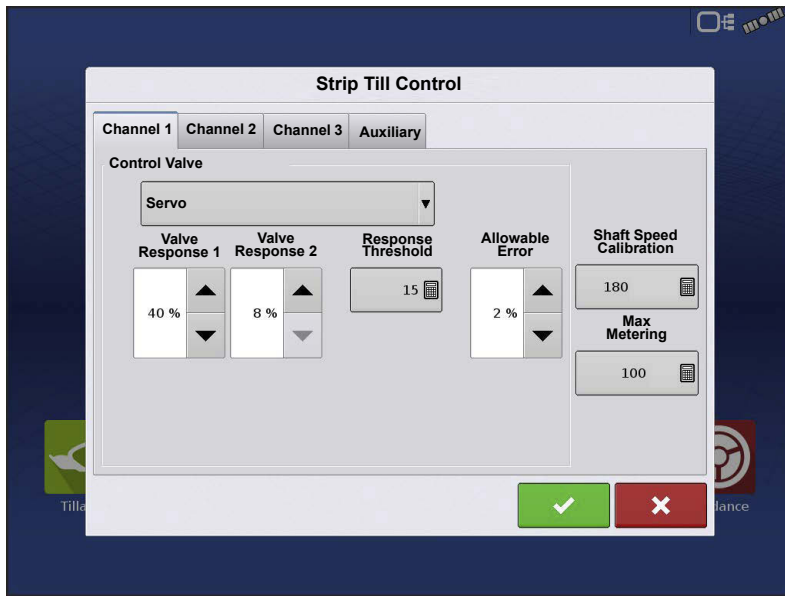

**Valve Response 1**—Determines the speed of the servo valve when product control error exceeds the Response Threshold setting. Represents the fast speed of the servo valve. Decreasing the value will cause the servo valve to run slower. The default setting is 40%.

**Valve Response 2**—Determines the speed of the servo valve when product control error is less than the Response Threshold setting. Represents the

slow speed of the servo valve. Decreasing the value will cause the servo valve to run slower. The default setting is 8%.

**Response Threshold**—Determines where the control channel switches between using Valve Response 1 and Valve Response 2 speed setting. Leaving all other valve control settings at the default value and making a small adjustment to this setting is usually all that is required to fine tune system performance. The default setting is 15.

- Decreasing this value will have the overall effect of speeding up servo valve response.
- Increasing this value will have the overall effect of slowing servo valve response.

**Allowable Error** —Determines the percent of error that is allowed prior to the product control system making any flow rate changes. 2% - 3% is the normal dead band setting range.

- Too low of a setting value can cause the product control system to continually hunt for the target application rate.
- Too high of a setting will cause excessive product application error.

**Shaft Speed Calibration**—Calibration number representing the pulses that equal one revolution of the rate control metering system.

**Max Metering Speed**—Setting determines the maximum RPM of the metering shaft that controls product distribution to the application point. This setting is used when controlling a granular strip-till toolbar.



## Strip Till Control: PWM Control Valve

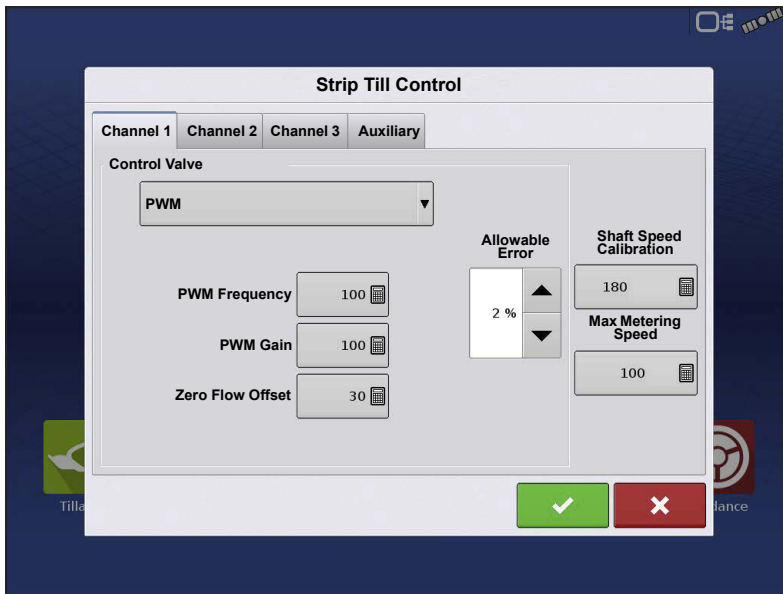

**PWM Frequency**—The frequency that the PWM control valve is pulsed at. Settings can be found from the manufacturer of the valve. Typical settings range from 100-125 Hz. The default setting is 100.

**PWM Gain**—Determines how aggressively the control valve responds when making rate changes. The higher the value the more aggressive the system response is.

The default setting is 100.

**Zero Flow Offset**—Represents the maximum duty cycle that is sent to the control valve without producing any hydraulic flow from the PWM valve. Using too high of a Zero RPM Offset value can cause the conveyor to not properly shut off. See the PWM valve manufacturer information for recommended settings. The default setting is 30.

**Allowable Error**—Determines the percent of error that is allowed prior to the product control system making any flow rate changes. 2% - 3% is the normal dead band setting range.

- Too low of a setting value can cause the product control system to continually hunt for the target application rate.
- Too high of a setting will cause excessive product application error.

**Shaft Speed Calibration**—Calibration number representing the pulses that equal one revolution of the rate control metering system.

**Max Metering Speed**—Setting determines the maximum RPM of the metering shaft that controls product distribution to the application point. This setting is used when controlling a granular strip-till toolbar.

---

## Linear Actuator/Clutch Settings



**NOTE!:** When using Linear Actuator Control, the system requires the Control Valve Configuration on all three channels to be set the same.

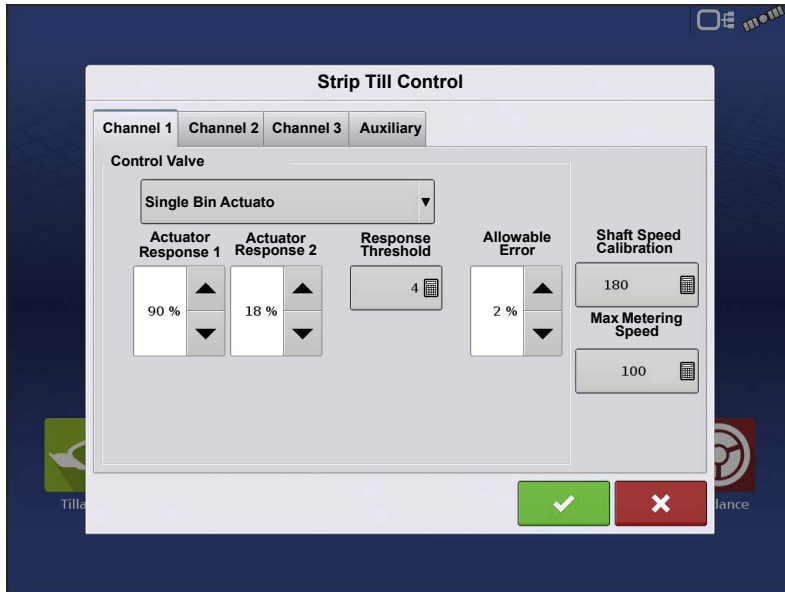

**Actuator Response 1**—Determines the speed of the actuator when product control error exceeds the Response Threshold setting.

Represents the fast speed of the actuator. Decreasing the value will cause the actuator to run slower. The default setting is 90%.

**Actuator Response 2**—Determines the speed of the actuator when product control error is less than the

Response Threshold setting. Represents the slow speed of the actuator. Decreasing the value will cause the actuator to run slower. The default setting is 18%.

**Response Threshold**—Determines where the control channel switches between using Actuator Response 1 and Actuator Response 2 speed settings. Leaving all other actuator control settings at the default value and making a small adjustment to this setting is usually all that is required to fine-tune system performance. The default setting is 4.

- Decreasing this value will have the overall effect of speeding up actuator response.
- Increasing this value will have the overall effect of slowing actuator response.

**Allowable Error**—Determines the percent of error that is allowed prior to the product control system making any flow rate changes. 2% - 3% is the normal dead band setting range.

- Too low of a setting value can cause the product control system to continually hunt for the target application rate.
- Too high of a setting will cause excessive product application error.

**Shaft Speed Cal**—Calibration number representing the pulses that equal one revolution of the rate control metering system.

**Max Conveyor Speed**—Setting determines the maximum RPM of the conveyor that controls product distribution to the application point.

**Actuator/Clutch Configuration**—Selecting one of the three available actuator/clutch settings: [Single Bin Actuator], [Multiple Bin Actuator, Main Only], [Multiple Bin Actuator, Main + Channel] from the Control Valve Configuration drop-down menu (above) determines specific behavior of the actuators/clutches on zero rate.

## Actuator/Clutch Logic

Determines Actuator/Clutch Behavior on Zero Rate

Control Valve Configuration	Control Component State	
	Control Channel RPM Commanded to Zero Other than by Master Switch Off	Master Switch Off
Single Bin Actuator	Main Clutch Output = Off Channel Clutch Output = Off Linear Actuator = Hold	Main Clutch Output = Off Channel Clutch Output = Off Linear Actuator = Hold
Multiple Bin Actuator, Main Only	Main Clutch Output = On Channel Clutch Output = Off Linear Actuator = Close	Main Clutch Output = Off Channel Clutch Output = Off Linear Actuator = Hold
Multiple Bin Actuator, Main + Channel	Main Clutch Output = On Channel Clutch Output = Off Linear Actuator = Hold	Main Clutch Output = Off Channel Clutch Output = Off Linear Actuator = Hold

## Strip Till Control: Auxiliary Tab

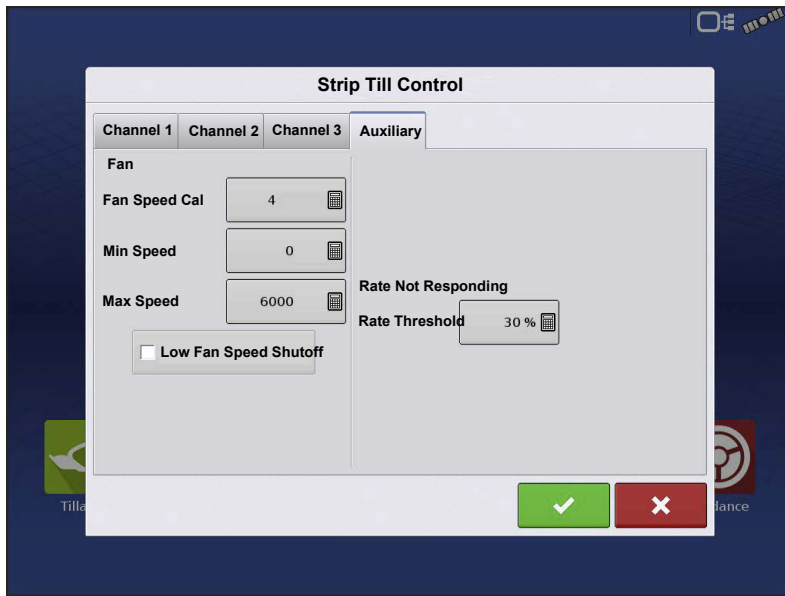

**Fan Speed Cal**—Number of pulses that are generated by the sensor during one revolution of the blower fan shaft.

**Min Speed**—Setting represents the desired minimum speed of the blower fan. An alarm will sound if the blower fan speed falls below this value.

**Max Speed**—Setting represents the desired maximum speed of the blower fan. An alarm will sound if the blower

fan speed exceeds this value.

**Rate Threshold**—Percentage difference between the Actual Rate and the Target Rate when the Rate Not Responding Message is displayed on the Run screen.

**Low Fan Speed Shutoff**—When selected, granular product application of a strip-till toolbar will be shut off if fan speed drops below the Min Speed setting.

## Run Time Operations

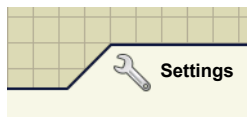

During Run Time Operations, Strip Till operators can press the Settings button to open the Strip Till Control screen. At this screen, you can adjust Product

Density, Conveyor Rate and other settings.

- Each of these settings described below must be set for each individual Product Channel (bin).
- The **Product Density**, and the **Conveyor Rate** are all stored with each combination of product and control channel.

## Strip Till Control Screen

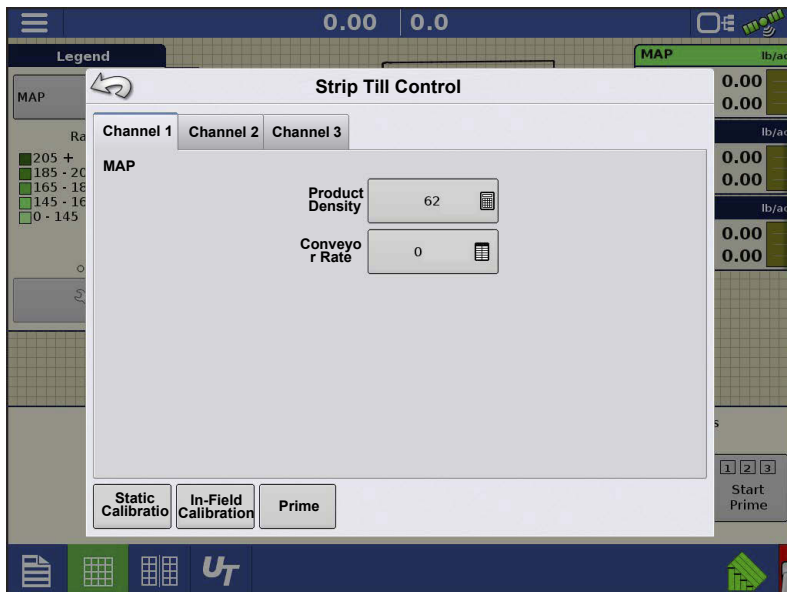

**Product Density**—This density value (shown in pounds per cubic foot, or lb./ft.<sup>3</sup>), is stored with each product.

Press  to edit value.

 **NOTE!** For proper machine performance and accuracy. Product Density should be measured for every application load.

**Conveyor Rate**—This setting represents the volume of product dispensed by one revolution of the conveyor drive shaft (cubic foot per revolution, or ft.<sup>3</sup>/rev.) This number is shown with the assumption that the conveyor shaft has a 1-inch gate opening.



**ATTENTION!** You must either manually enter conveyor rate value or perform a CFR calibration routine for each product and channel combination, otherwise misapplication will occur.

**Static Calibration**—Press the Static Calibration button to perform an automated routine to calibrate each metering circuit. This calibration is performed before applying in field conditions.

- For hydraulic drive systems, see [Static CFR Calibration Procedure for Hydraulic Drive systems on page 866](#).
- For ground drive systems see [Static CFR Calibration Procedure for Ground Drive Systems on page 867](#).







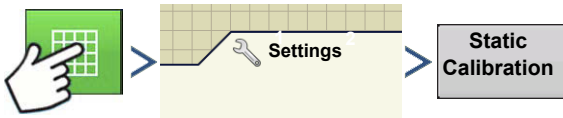

**In-Field Calibration**—Press the In-Field Calibration button to perform an automated routine to adjust the calibration number for the selected metering circuit. This calibration is performed if there is a difference between the amount of product logged as compared to what was actually applied. For more information, see [In-Field Calibration Procedure on page 868](#).

---

## Static CFR Calibration Procedure for Hydraulic Drive systems

You must perform a calibration for each granular product control channel (bin) for the equipment configuration before applying in field conditions. This process is outlined below and on the following page. The Static CFR Calibration Procedure performs an automated routine to calibrate each metering circuit.



1. **Read Static Calibration warning**—A warning appears, advising to disable the blower fan circuit and prepare to catch any product dispensed in an appropriate container. Press  to continue.
2. **Select Metering Circuit to Calibrate**—The CFR Calibration Wizard appears. Use the drop-down menu to choose the desired channel to calibrate. Press  to continue.
3. **Enter Dispense Amount**—Press  to enter the amount of product to be dispensed into the container. Press  to accept value. Press  to continue.
4. **Enter Simulated Target Rate**—Press  to enter a simulated target rate, shown in pounds per acres. Press  to accept value. Press  to continue.



5. **Start Target Rate Countdown**— Press the start button to begin metering product. The metering circuit will stop automatically when the system perceives the simulated target rate has been dispersed. As the countdown is started, the button will turn red and state Stop. When the countdown is complete, press  to continue.

6. **Enter Actual Dispense Amount**—Enter the actual dispense amount, in pounds. Press



 to continue.



**NOTE!:** The CFR will be calculated from the actual product amount dispensed.

### 7. Calibration Complete



A message appears, stating that your calibration is complete, and showing the CFR amount, in cubic feet per revolution. Either:

- Press  to exit the calibration without saving the value.
- Press **Repeat Calibration** to begin the process again.
- Press  to save the value and exit the calibration routine.

## Static CFR Calibration Procedure for Ground Drive Systems

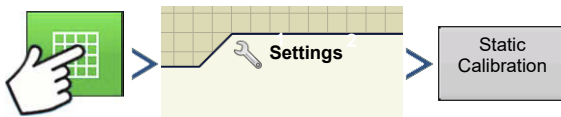
The Static CFR Calibration Procedure performs an automated routine to calibrate each metering circuit. This calibration is performed before applying in field conditions. This process is outlined below and on following page.



1. **Read Static Calibration warning**—A warning appears, advising to disable the blower fan circuit and prepare to catch any product dispensed in an appropriate container. Press  to continue.
2. **Select Metering Circuit to Calibrate**—The CFR Calibration Wizard appears. Use the drop-down menu to choose the desired channel to calibrate. Press  to continue.

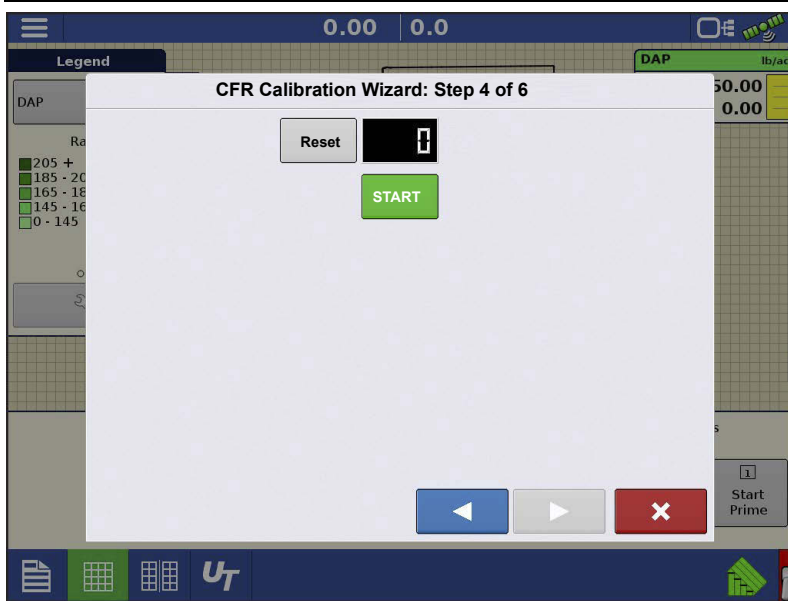

### 3. Start Target Rate Countdown—

Press the Start button and turn drive shaft a desired amount of revolutions.

The system counts revolutions of the shaft encoder.

Press the Stop button once finished.



Press  to continue.

### 4. Enter Actual Dispense Amount—

Enter the actual dispense amount, in pounds. Press  to continue.

 **NOTE!:** The CFR will be calculated from the actual product amount dispensed.

5. **Calibration Complete**—A message appears, stating that your calibration is complete, and showing the CFR amount, in cubic feet per revolution. Either:

- Press  to exit the calibration without saving the value.
- Press **Repeat Calibration** to begin the process again.
- Press  to save the value and exit the calibration routine.

## In-Field Calibration Procedure

The In-Field CFR Calibration procedure performs an automated routine to adjust the calibration number for the selected metering circuit. This calibration is performed if there is a difference between the amount of product logged as compared to what was actually applied.

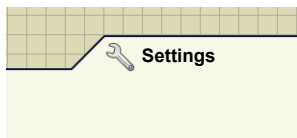



To begin, press the **Settings** button on the Map screen. The **Strip-Till Control** screen opens. Press the **In-Field Calibration** button. The **In-Field CFR Calibration Wizard** appears.

1. **Select Metering Circuit to Calibrate**—Use the drop-down menu to select the channel to calibrate, and press  to continue.



2. **Enter Actual Weight**—The Accumulated Weight is shown in the top portion of the screen.

Press  to enter the Actual Weight applied, and press  to continue.



**NOTE!:** Start a new Region to reset the Accumulated Weight to 0 lbs.

3. **Calibration Complete**—A message appears, stating that your calibration is complete, and showing the CFR amount, in cubic feet per revolution. Press  to finish the calibration.

## Meter Prime

Meter Prime is for Hydraulic Drives ONLY.

1. Press the **Settings** button.

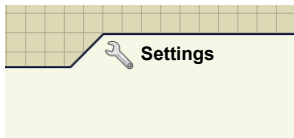

The Strip Till Control screen appears.

2. Press the **Prime** button to access the Air Cart Prime screen.

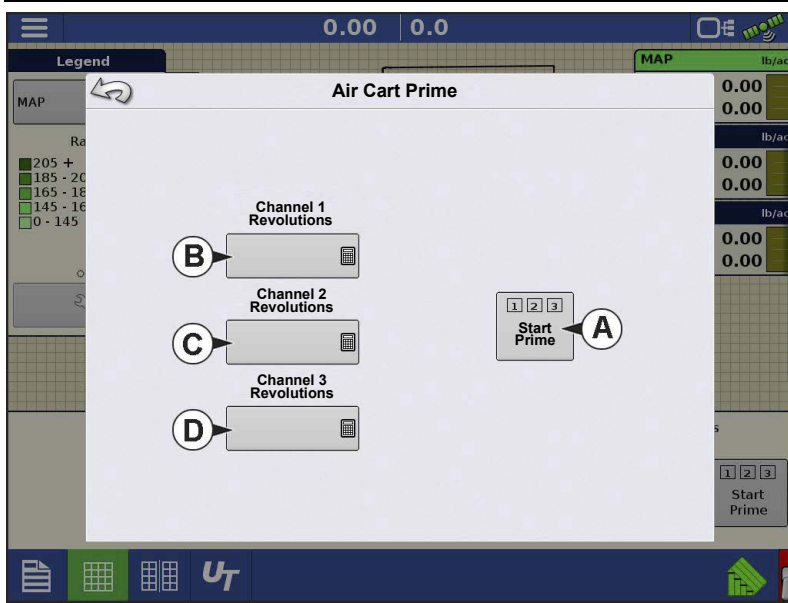

3. The Air Cart Prime screen appears with input buttons for each channel used. The setting determines the revolutions necessary to prime the meter shaft. Settings are independent by channel, and can be entered using



- a. Start Prime
- b. Channel 1 Revolutions
- c. Channel 2 Revolutions
- d. Channel 3 Revolutions



**NOTE!:** Meter Prime routine is not available and remains hidden for ground driven metering configurations.

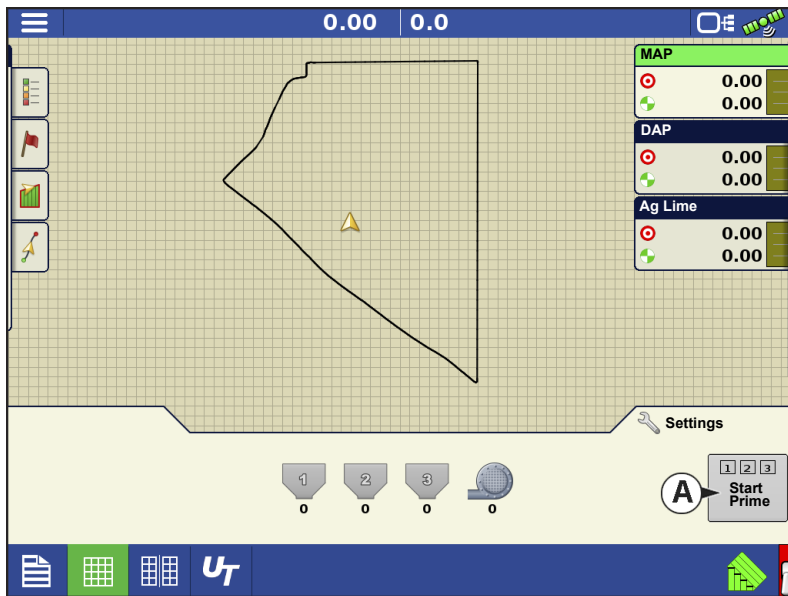

The **Start Prime** button (A) begins the meter prime routine and each meter shaft will rotate the number of revolutions as defined on the Air Cart Prime Screen.

## Fertilizer Default Product Settings

Material	Type	Abbreviated name for display and predefined name for SMS™	Percentage (in terms of lbs.100 lbs.)			Density
			N	P (P2O5)	K (K2O)	
Ammonium nitrate	Dry	Ammonium nitrate	34	0	0	N/A
Ammonium phosphate	Dry	Ammonium phosphate	10	34	0	N/A
DAP	Dry	DAP	18	46	0	N/A
MAP	Dry	MAP	11	52	0	N/A
Ammonium sulfate	Dry	Ammonium sulfate	21	0	0	N/A
Urea	Dry	Urea	46	0	0	N/A
Potash	Dry	Potash	0	0	60	N/A
Triple superphosphate	Dry	Triple superphosphate	0	46	0	N/A
Ordinary superphosphate	Dry	Superphosphate	0	20	0	N/A
Potassium nitrate	Dry	Potassium nitrate	13	0	44	N/A



## Raven ISOBUS PWM Nozzle Control with the InCommand 1200 Display

Properly configure the Raven UT/ECU settings before manually create a Generic ISOBUS controller in the display configuration.

**i** **NOTE!:** Ag Leader is not responsible for proper Raven configuration/setup/button presses. Dealers/customer should work with a Raven dealer for proper Raven settings.

**i** **NOTE!:** The "HD" in Raven ISOBUS PWM Nozzle Control is an Unlock that must be entered into the Raven ECU for nozzle by nozzle control.

- Raven ECU has to be on version 2.2 or newer
- InCommand must be on version 2.5 or newer (must use Generic ISOBUS Controller Configuration, NOT Load-and-go).

Configure it in the InCommand as a Generic ISOBUS controller rather than using Load-and-go. Using Load-and-go will cause the configuration to not match when settings are changed in the Raven UT.

### Setting up Configuration for the First Time

#### Enable Universal Terminal and Task Controller

To enable the Universal Terminal:

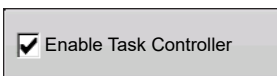
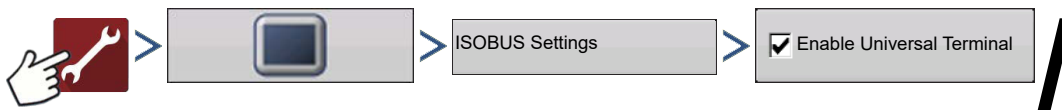

Once a Universal Terminal has been enabled

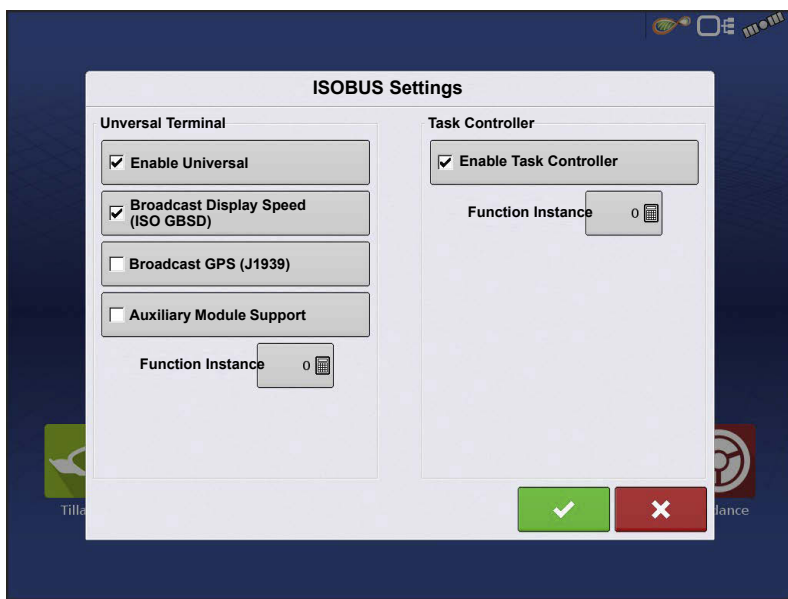

The button will appear in the task bar:



Toggle between the Universal Terminal run screen and other display functions by pressing the UT button.

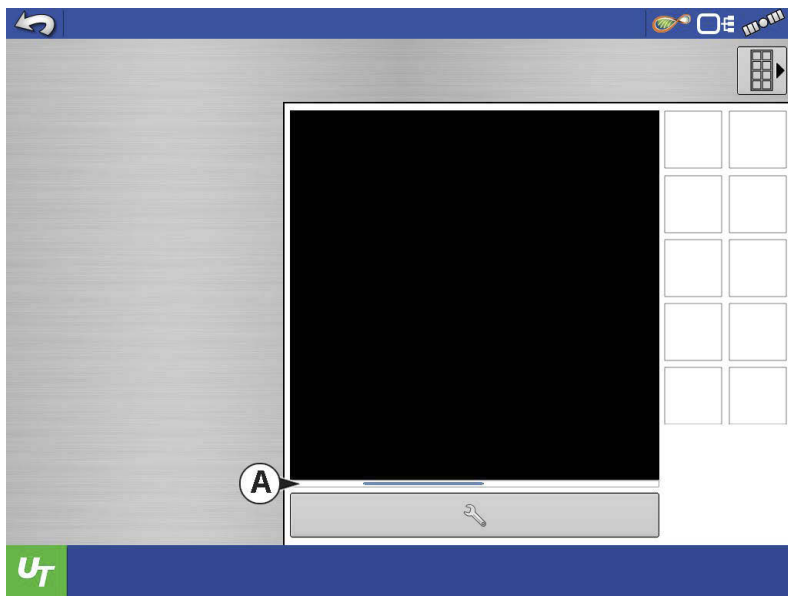

Status Bar (A) appears while Object Pool is in the process of loading.

## Create Configuration

1. Press . A wizard will step you through the process of creating a configuration.

### 2. Operation Configuration Selection

Press  to create a configuration

### 3. Operation Configuration: Vehicle

Press  to add a vehicle.

### 4. Vehicle Wizard: Vehicle Type

Select Vehicle Type. Press  to continue.

### 5. Vehicle Wizard: Make and Model

Enter Make and Model. Press  to continue.

### 6. Vehicle Wizard: Application Channels

**IMPORTANT!: REMOVE the Application Channel that exists from the Load-and-go. The following steps will instruct you on how to make a Generic ISOBUS configuration to use in place of the Load-and-go configuration that was deleted.**

### 7. Vehicle Wizard: Application Channels

Select "+Liquid Application".

### 8. Equipment Setup Wizard: Rate Controller

Press  to create a controller.

### 9. Controller Setup Wizard: Device

Select "ISOBUS" for device. Press  to continue.

### 10. Controller Setup Wizard: Make and Model

Select "Generic" for Make. Press  to continue.

### 11. Controller Setup Wizard: Controller Name

Input a name for the Controller. Press  to accept.

### 12. Equipment Setup Wizard: Rate Controller

Select the controller you just created. Press  to continue.

---

### 13. Equipment Setup Wizard: Application Channels

Enter the number of Application Channels. This can be found in the CAN B list. Press  to continue.

### 14. Equipment Setup Wizard: Container

Enter a container name, capacity, and units. Press  to continue.

### 15. Equipment Setup Wizard: Section Count

Enter the number of Boom Sections. This can be found in the CAN B list. Press  to continue.

### 16. Equipment Setup Wizard: Swath Width

Enter Swath Width. Press  to continue.

### 17. Equipment Setup Wizard: Application Point Offset

Enter distance from Rear Axle to Application Point. Press  to accept.

### 18. Vehicle Wizard: Application Channels

Press  to continue.

### 19. Vehicle Wizard: Additional Devices

Select if applicable. Press  to continue.

### 20. Vehicle Wizard: Vehicle Name

Enter Name. Press  to accept.

### 21. Operation Configuration: Vehicle

Select vehicle you just created. Press  to continue.

### 22. Operation Configuration: Speed Source

Select. Press  to continue.

### 23. Operation Configuration: Configuration Name

Enter Name. Press  to accept.

### 24. Configuration Setup Screen

View. Press  to accept.

### 25. Operation Configuration Selection

Select. Press  to accept.





**NOTE!:** Not following this procedure may cause the HD (nozzle by nozzle) unlock in the ECU to become unavailable when changing nozzle configurations. If this happens, reset the controller ECU and perform the setup again ensuring Load-and-go is not used.”



## DirectCommand® L2 Rate Controller

DirectCommand L2 monitors and controls variable rate application of up to 8 liquid products.

### Load Configuration



Press the Application App from the home screen to load a configuration.

### Map View

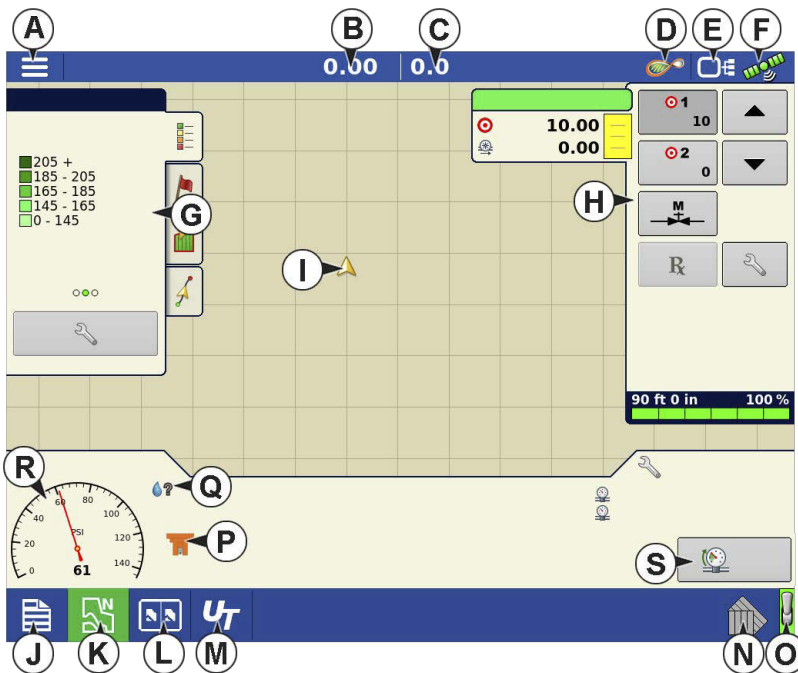

- A. Menu button
- B.Total Logged Field Area
- C.Ground Speed
- D.AgFiniti® Status
- E.Diagnostics
- F.GPS Signal Indicator
- G.Display Legend
- H.Product Control Toolbox
- I.Vehicle Icon
- J.Event Summary
- K.Map View
- L.Split Screen
- M.Universal Terminal
- N.AutoSwath Toggle Switch
- O.Master Switch Indicator
- P.Nozzle Indicator
- Q.Droplet Size Indicator
- R.Pressure Gauge
- S.Boom Prime



**NOTE!:** Pressing the Map View button will cycle between the available Map screen views, and the appearance of the Map View button changes.

# Product Control Toolbox

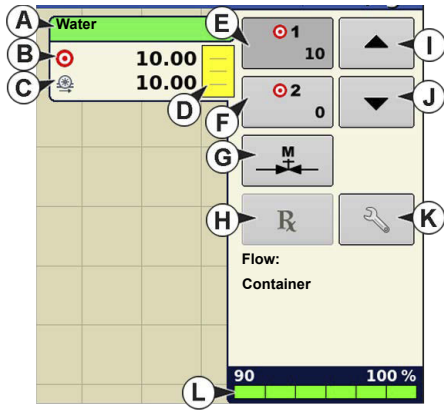

During DirectCommand™ Run Time operations, the Product Tabs are shown in the upper right-hand side of the Map screen. Press the Product Tabs, and an extended view shows the Rate buttons, Manual Valve Control button, Prescription button, Rate Increase and Rate Decrease arrows, and the Rate Setup button, all of which are described below.

- |                    |                             |
|--------------------|-----------------------------|
| A. Product         | G. Manual Valve Control     |
| B. Target Rate     | H. Prescription button      |
| C. Actual Rate     | I. Rate Increase button     |
| D. Container Level | J. Rate Decrease button     |
| E. Rate 1 button   | K. Rate Control Settings    |
| F. Rate 2 button   | L. Section Status Indicator |



**Target Rate** — The Target Rate is desired application rate.



**NOTE!** In some conditions, the Target Rate may increment more quickly than the Actual Rate.



**Actual Rate** — The Flow Sensor returns the actual rate being applied.



**Container Level** — The Container Level shows the amount of product in the container.



**Rate 1 and Rate 2** — The Rate 1 and Rate 2 settings represent preset application rates that allow operators to quickly change between desired target rates for each individual product.



**Manual Nozzle Valve Control** — Allows operators to adjust the duty cycle of the nozzle valves. Operators can use this to prime the system before application, clean out equipment at the end of the day, or check the functionality of the valves.



**Increase and Decrease** — Increase/Decrease target rate and when in manual control they increase/decrease duty cycle of Nozzle Valve Assemblies.



**Prescription**



**Rate Control Settings** — Select the wrench to enter Rate 1 and 2, Increment, Minimum Flow, Prescription, and access to container settings.

## Boom Prime



Boom Prime allows the boom to be pressurized with the master switch off prior to applying.

To engage, select the Prime button in the bottom right corner of the run screen.

To disengage select the boom prime button again or flip the master and begin applying.

The master switch must be off for Prime to be accessible. When prime is selected it will prime to the boom valves.



**NOTE!** When using a Servo Valve, Rate Off setting must be set to Maintain Standby Pressure for Prime to be available.

## Rate Control Settings



Adjust the Rate 1 and Rate 2 settings shown at the Product Control Toolbox on the Map screen, as well as import application product prescriptions. To access the Rate Control Settings screen, press the Rate Setup button on the Product Control Toolbox. The Rate Control Settings screen appears.

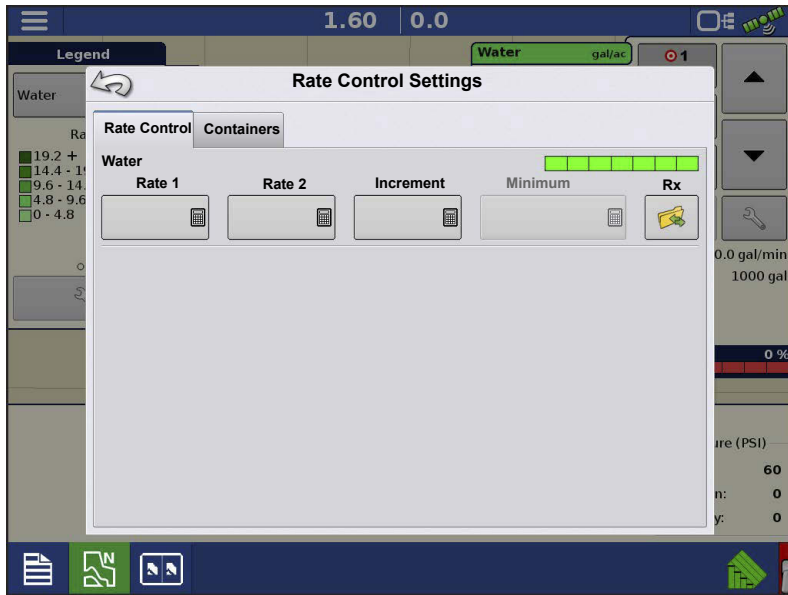

**Rate 1 and Rate 2** — The Rate 1 and Rate 2 settings represent preset application rates that allow operators to quickly change between desired target rates for each individual product.

Press  to enter the desired amount.

**Increment** — The Increment button allows operators to specify the

increase or decrease amounts for a specified rate by using ▲ / ▼ on the Product Control to enter the desired.

**Prescription** — To load a map-based prescription file, press the Prescription button.

Refer to “Loading Prescriptions” on page 4 for further detail.

**Minimum Flow** — This setting is used to maintain a consistent spray pattern. The display will not allow flow to drop below the entered setting. Set to flow at the lowest operating pressure for the selected spray tips with all sections on. When spraying with one or more boom sections off, the system automatically reduces the Minimum Flow setting according to the reduced spray width. To adjust this setting, press  and enter the desired numeric value.



**NOTE!:** Value will be greyed out when nozzle is selected. Minimum flow will be calculated based upon nozzle selection.

## Containers

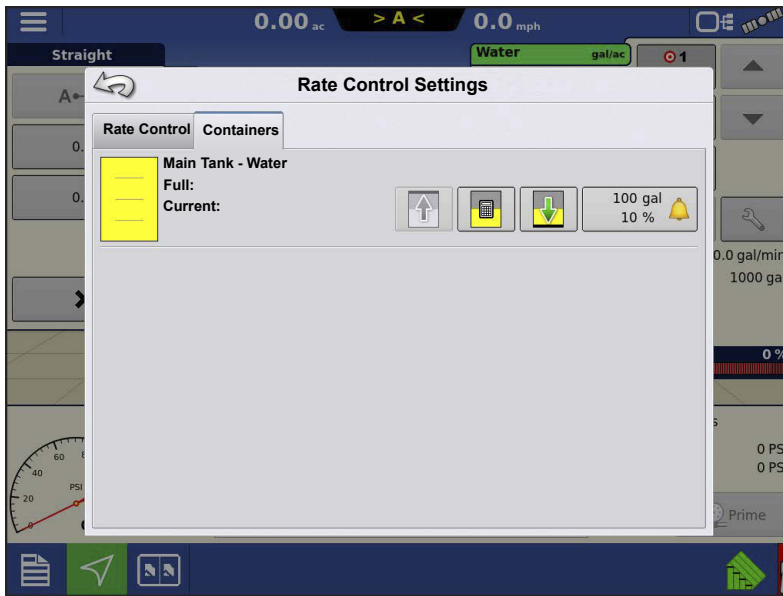

### Main Tank



Select to fill tank



Select to empty tank



Select to enter a specific amount

## Fill Flow Meters

DirectCommand L2 and RightSpot, when paired with Ag Leaders Vehicle Interface Module (VIM), offers automatic tank fill. This feature eliminates the need to manually adjust the container level.

## Raven Fill Stations

Raven Fill Stations are compatible with DirectCommand L2 and RightSpot when paired with the VIM. Machines must be equipped with Raven Fill Stations from factory.

## Liquid Control Options



- A.Nozzle Selection
- B.Product Density
- C.Tune Valve
- D.Pressure Calibration
- E.Flow Meter Calibration
- F.Agitation Pressure

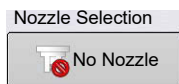

**Nozzle Selection** – Click the icon to open the selection options. Select an existing nozzle that matches the nozzle you are using or create a custom nozzle. A nozzle selection is required for pressure-based control.

**Product Density** – Enter the products Density.

**PWM Valve Tuning Utility** — Easily tune PWM valve settings from the run screen.

**Pressure Calibration** — Calibrate pressure sensor from the run screen.

**Flow Meter Calibration** — Calibrate flow meter from the run screen.

**Agitation Pressure** – Enter the pressure needed for agitation.



**NOTE!**: Agitation pressure control requires L2 to be connected to the sprayer agitation valve and an agitation pressure sensor.



## Nozzle Selection

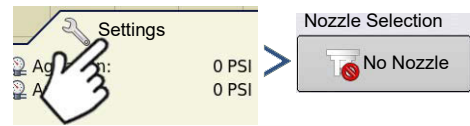
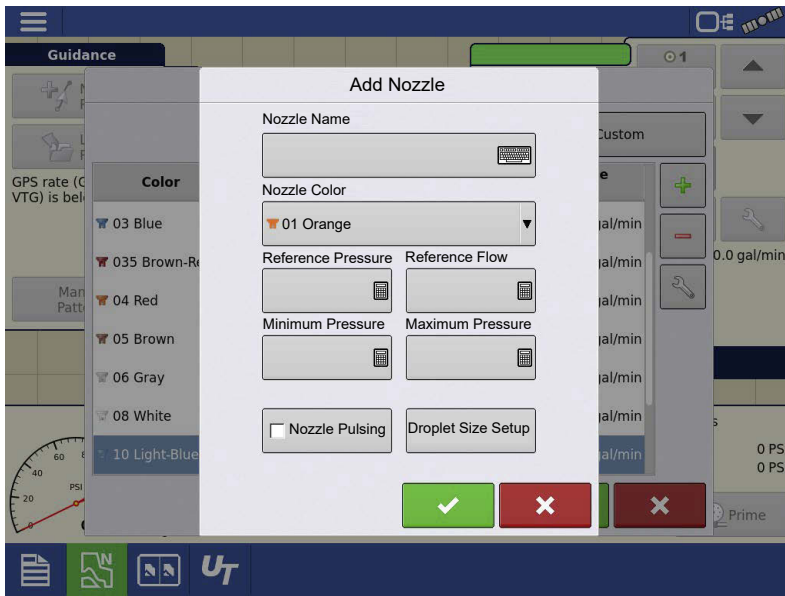

OR

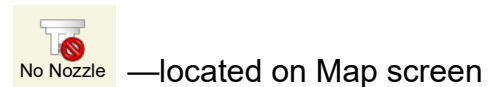

Nozzle selection is required. Generic nozzles are available to use for basic functionality.

### Functionality Requiring a Custom Nozzle

The user must create a custom nozzle, and input the appropriate settings, to perform advanced functionality such as:

- Droplet size monitoring
- Minimum flow capabilities
- Custom values for flow capacity,
- Alerts when operating outside the effective pressure range of the nozzle

### Creating a Custom Nozzle

1. Select 

2. Enter:

- Nozzle Name
- Nozzle Color
- Reference Pressure
- Reference Flow
- Minimum Pressure
- Maximum Pressure

Nozzle Pulsing

Nozzle Pulsing will never be checked with DirectCommand L2 only. This feature requires RightSpot to be installed.

Droplet Size Setup

Enables the droplet size reference to the pressure gauge on the map screen.



Enter the Minimum Pressure for each droplet size.

## Product Density

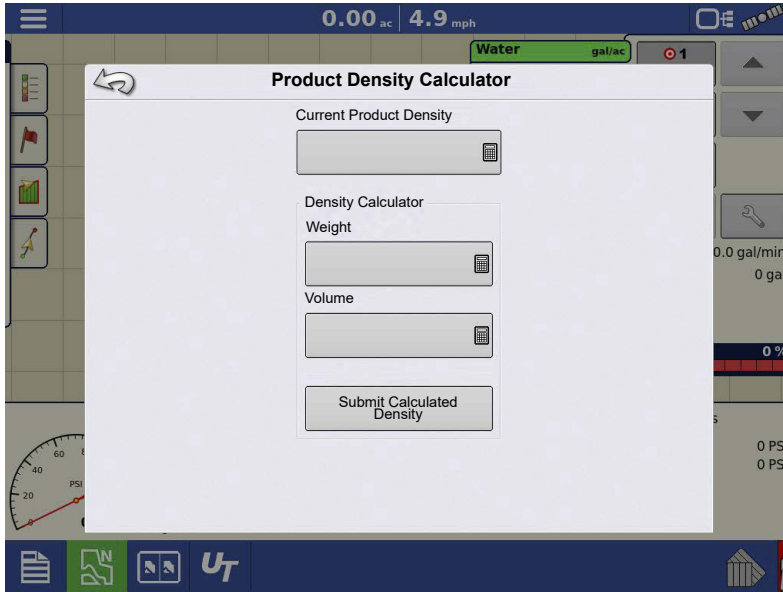
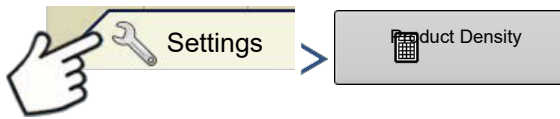

Enter product density for a generic product or mix created. Products made that are already in the display will already contain the density.

If density is not known for a generic product, use the calculator for an accurate density.

## PWM Valve Tuning Utility

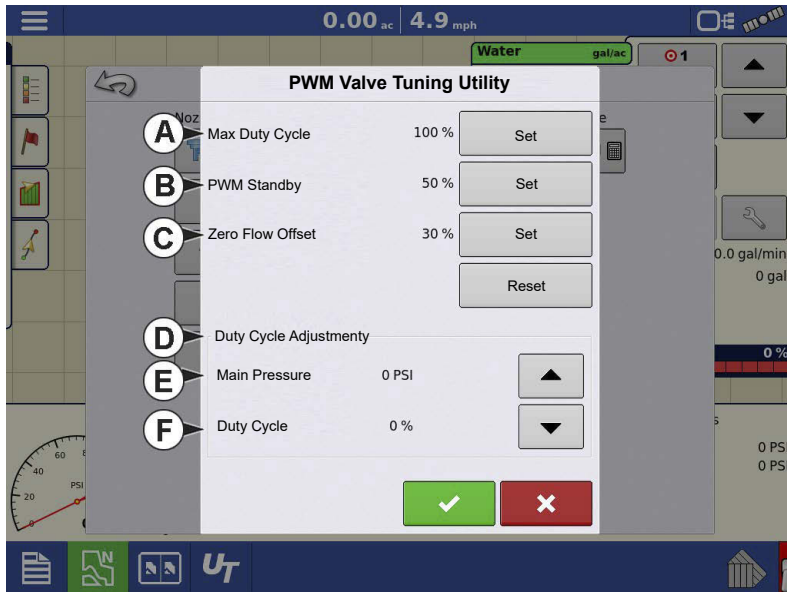
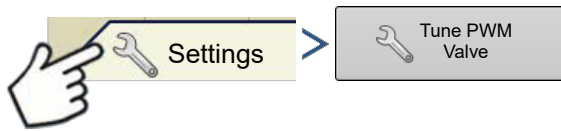

Easily adjust the PWM Flow Control Valve settings from the run screen.

**A. Maximum Duty Cycle** — Sets an upper limit for duty cycle. The valve will not operate at a higher duty cycle than the percent entered.

**B. PWM Standby** — User defined setting that determines the percent duty cycle the system uses when boom sections are all off. This setting must be greater than the Zero Flow Offset.

**C. Zero Flow Offset** — Maximum duty cycle that is sent to the control valve without producing flow from the product pump. Default value is 30. Use the Duty Cycle Adjustment tool achieve the correct setting.

**D. Duty Cycle Adjustment** — ▲ / ▼ allow the user to command a duty cycle to the product control valve without dispensing product. This allows the user to increase or decrease the pump output and observe the resulting response to help set the desired duty cycle for the above settings.

**E. Main Pressure** — The current reading from the systems calibrated pressure sensor

**F. Duty Cycle** — Percentage the L2 rate controller is sending to the valve.



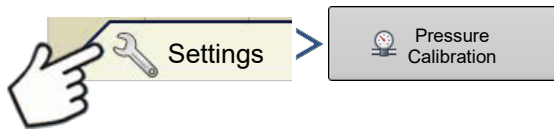

**NOTE!:** To fully adjust the Flow Control Valve access the Control Valve Settings. See [Control Valve Settings on page 921](#).

## Pressure Calibration



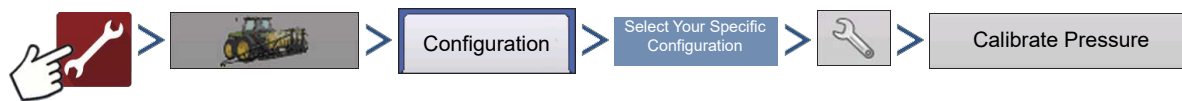



OR







1. Choose Main, Agitation or Aux from Drop-down box. Press .

2. Select Set Point Type and Sensor type. Press .

**Single Set Point:** Enter Voltage / Pressure Ratio  Record Calibration Point (PSI must be zero before recording) .

**Single Set Point with Current Loop:** Enter Voltage / Pressure Ratio  With PSI of Zero, Record Calibration Point. Press .

**Multiple Set Point with Voltage:** Set pressure to 0 Psi and select Record Calibration Point  Enter the known boom pressure and Record Calibration Point. Press .

**Multiple Set Point with Current Loop:** Set pressure to 0 Psi and select Record Calibration Point  Enter the known boom pressure and Record Calibration Point. Press .

---

## Flow Meter Calibration

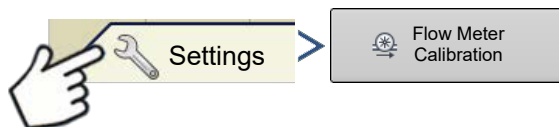

### 1. Select Calibration Type:

- Manual
- Field Dispense Volume
- Nozzle Catch Test.

Press .

#### **Manual**

Enter the pls/gal for the product control flow meter 1.

- This value can typically be found on the flow meter tag.
- Raven Flow meter pls/gal must be divided by 10 prior to enter value in display.
- Flow meter 2 is ONLY used if there are two product control flow meters on your system. If there is not, leave it to zero.

#### **Field Dispensed Volume**

Apply product for a desired amount of time. Once complete, verify the volume applied. Enter the Actual Volume Dispensed in the flow meter calibration window.

- The Volume measured is based on Current Region. It is suggested to create a new region prior to beginning Field Dispense Volume Calibration.

#### **Nozzle Catch Test**

Equipment needed: Pitcher or device to catch water and stop watch.

Enter the target rate and manual speed. Select Start. Select stop once desired time has passed. Enter the volume of solution collected and the time measured.

Flow meter calibration will calculate.

Complete calibration by selecting the .

## Anhydrous Ammonia (NH3)

### Load Configuration



Press the Application App from the home screen to load a configuration.

### Map View

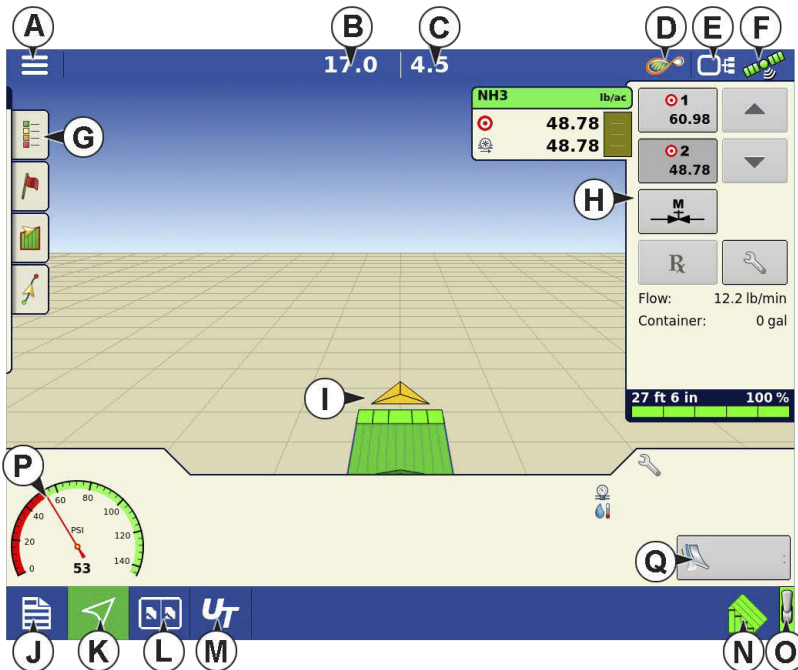

- A. Menu button
- B.Total Logged Field Area
- C.Ground Speed
- D.AgFiniti® Status
- E.Diagnostics
- F.GPS Signal Indicator
- G.Display Legend
- H.Product Control Toolbox
- I.Vehicle Icon
- J.Event Summary
- K.Map View
- L.Split Screen
- M.Universal Terminal
- N.AutoSwath Toggle Switch
- O.Master Switch Indicator
- P.Pressure Gauge
- Q.Tube Check



**NOTE!:** Pressing the Map View button will cycle between the available Map screen views, and the appearance of the Map View button changes.

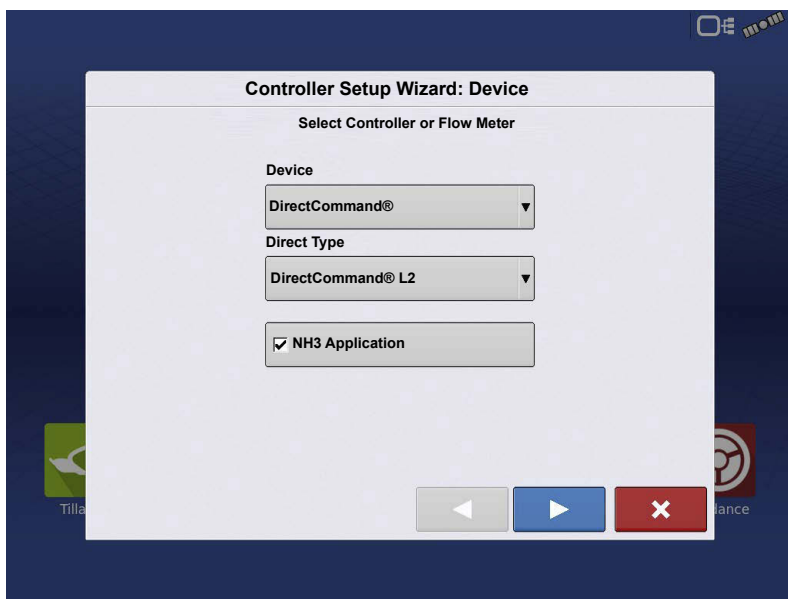

When building a controller in the configuration, check the NH3 Application box. This will allow the ability for vapor state monitoring and temperature monitoring when in the operating screen. Tube check will also become available.

## Calibrate Temperature Sensor

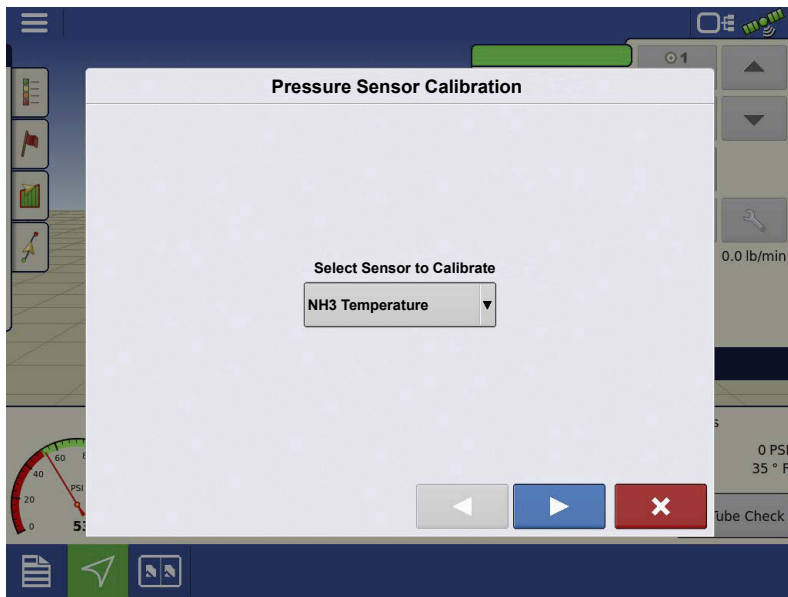

Calibrating the temperature sensor is done in the configuration by pressing the calibrate sensors button. In the drop down list, NH3 Temperature can be selected.



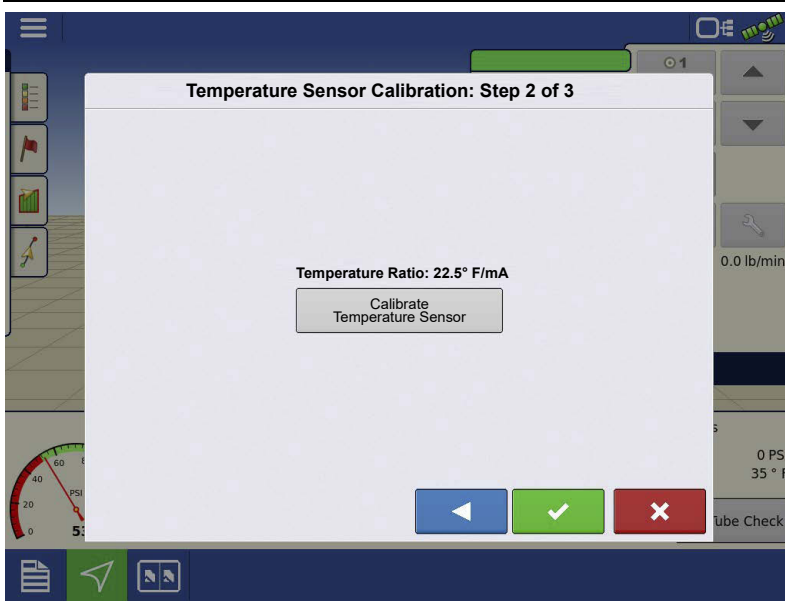

On step 2, press the calibrate temperature sensor button.

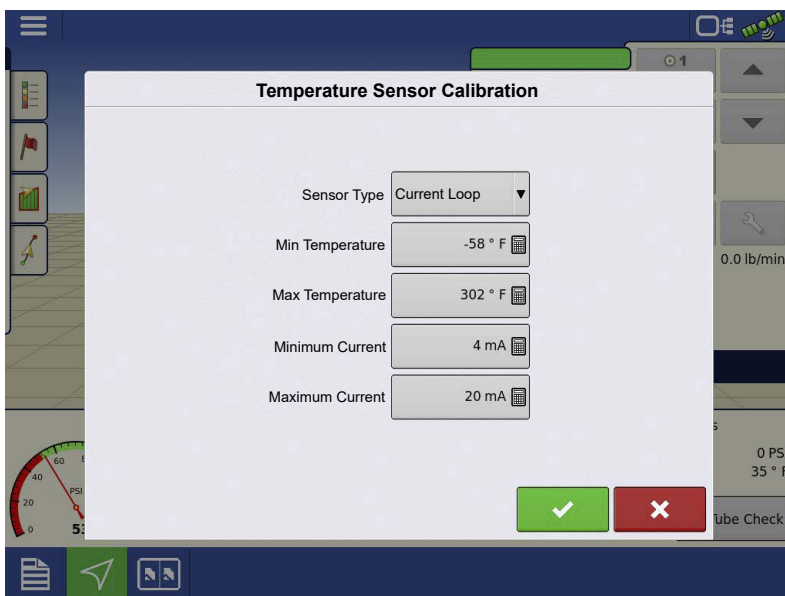

Enter in the appropriate values for the temperature sensor purchased. Default values are for an Ag Leader temperature sensor.

When values are entered, press  to successfully calibrate the sensor.

## Vapor State Monitoring

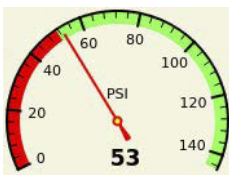

When NH3 Application is selected, vapor state monitoring is capable. In order to use the on screen gauge for vapor stator monitoring, a temperature sensor and main pressure sensor must both be installed and calibrated. Once both are installed and calibrated, the gauge will no display only red and green portions.

- When the gauge needle is in the Green area, NH3 is being applied in a liquid state.
- When the gauge need is in the Red, NH3 is being applied in a vapor state.

## Tube Check



This feature allows the operator to check for plugged knives or over-all obstructions with the toolbar raised. After pressing the Tube Check button, follow the on-screen instructions.



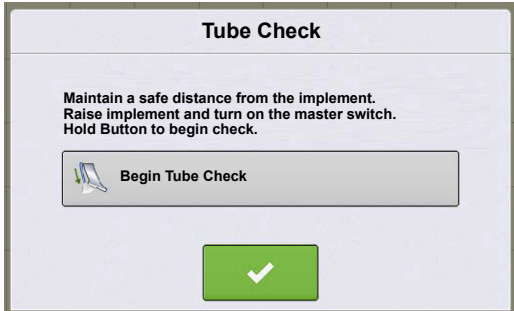

**NOTE!:** The Tube Check button will only be available for anhydrous ammonia configurations.



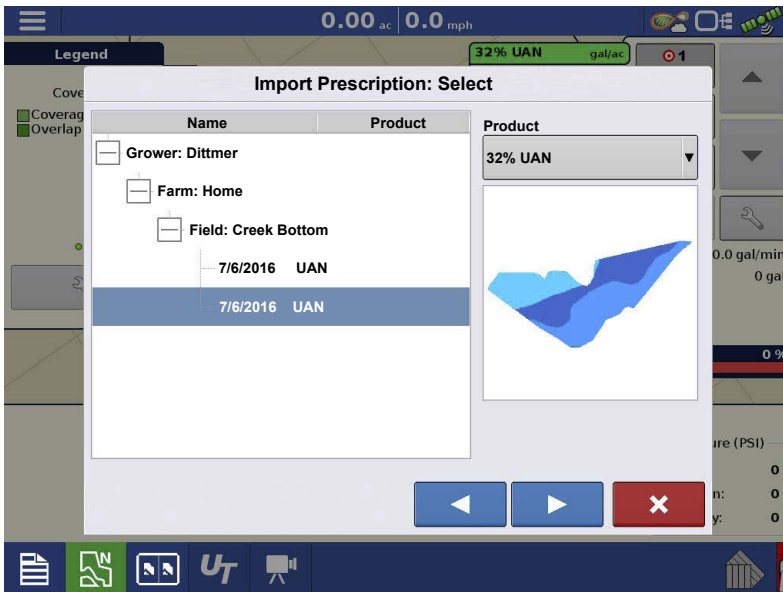

Press and hold the Begin Tube Check button to start the system. Section valve will open to allow product to be dispensed while implement is raised. Press the green check when finished.

## Loading Prescriptions



1.  Press the Rate Setup button on the Product Control Toolbox.

2. Press the Load Prescription button.

3.  Using an inserted USB or AgFiniti Cloud, search for and highlight the correct .agsetup, .irx, or shape file and press .

4. Select the prescription in the Select Prescription screen, and select the correct controlling product from the Product drop-down box. A preview prescription map is displayed.

5. Press .

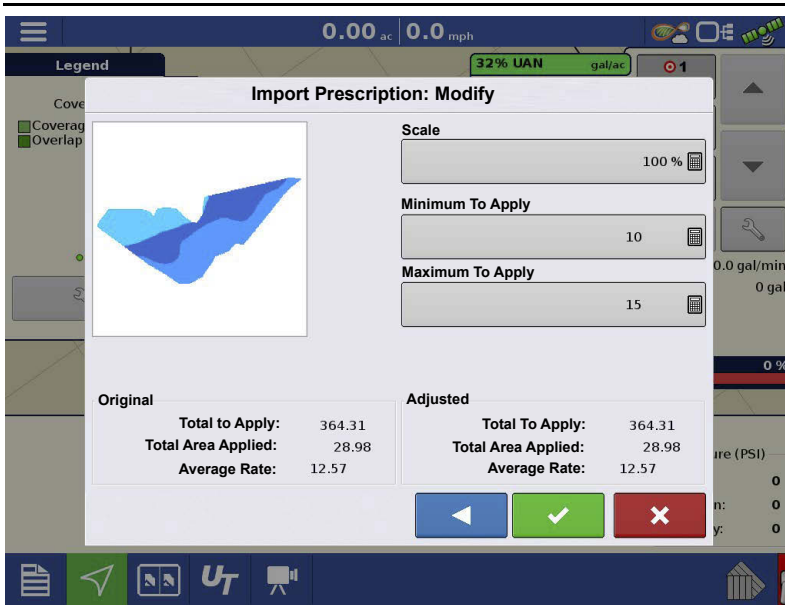

6. In the Modify Prescription Screen the prescription scale, minimum to apply, and maximum to apply can be changed. As the three parameters are changed, the adjusted total to apply and average rate will update accordingly.

7. Press the .

8. After returning to the Mapping Screen, the prescription will appear on the map while in a North Oriented view.

## Shape File Conversion

What is commonly called a shape file is actually a collection of different files. All three of the files are required and must be present on the USB drive for the system to use shape files for variable rate product application. A single shape file can contain recommendation rates for multiple products.



1. To begin, press the Rate Setup button on the Product Control Toolbox.

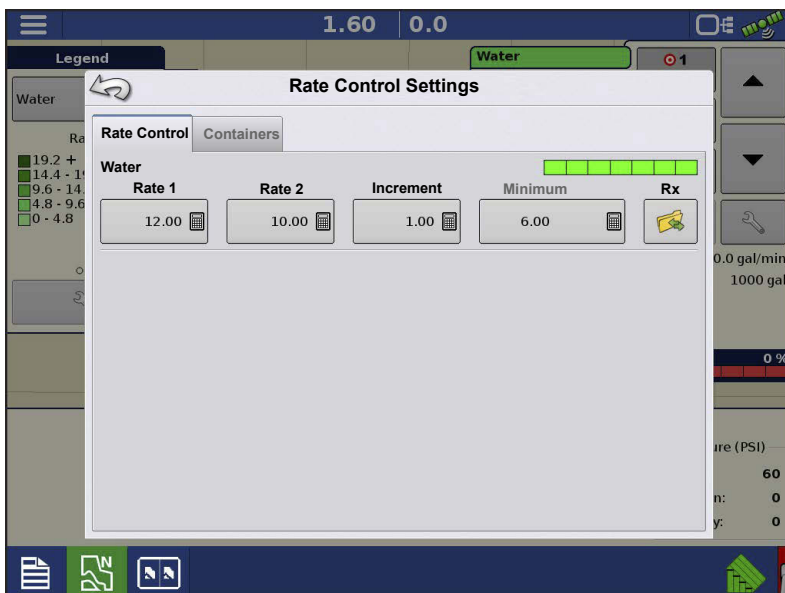

The Rate Control Settings screen appears

2. Press the Load Prescription button.



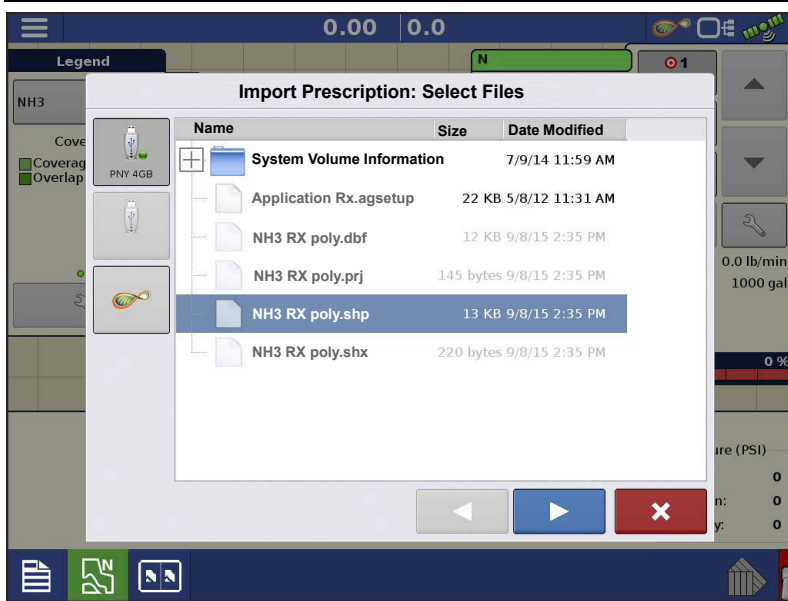

3. The Select File screen appears. Highlight desired .shp file and press

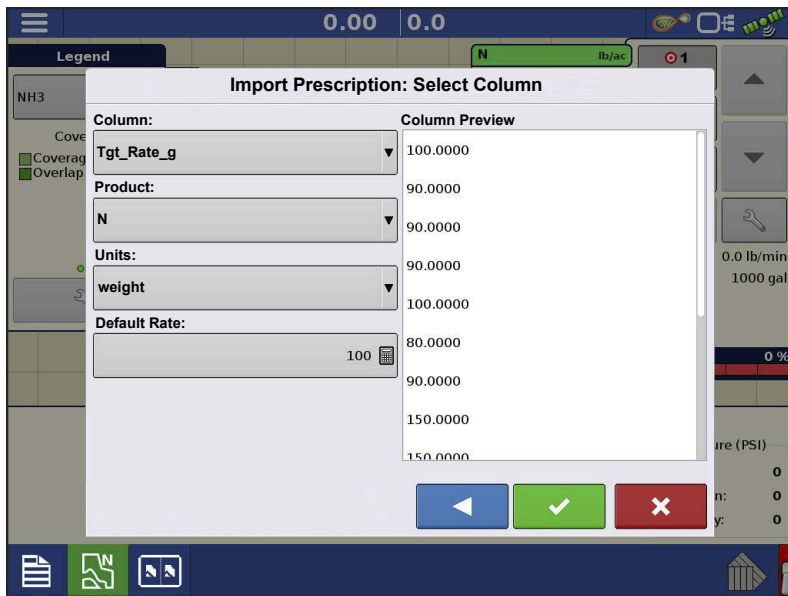

4. **Select Column From Shape File**—

Select the column that contains the product target rate. The list on the right side of the dialog shows sample data from the selected column.

5. **Select Units**—Select the controlling units for product application.

6. **Default Rate Setting**—The system assigns a default rate. Use the on-screen keypad to edit the value if desired.



**NOTE!** Select the product and units that the shape file prescription was made for. Selection of the wrong data column or unit will result in misapplication of product.



**ATTENTION!** The only time the default rate is used by the system during product application is if the Rate Outside of Field selection is set to "Rx default". This setting is located in the Equipment Settings portion of configuration setup. If the Rate Outside of Field selection is

set to "Rx default", the default target rate will be used when the vehicle exits the area covered in the prescription map.

## Creating Products

Creating application products and product templates can be completed during initial setup, or from the Product Selection screen of the Field Operation Wizard when starting a field operation.

### Creating Single Products

To create a single product, to be added to a product template or to be applied by itself, use the on-screen wizard described in the following steps.



Select:

1. Product Type
2. Product Units
3. EPA Product Number (Optional)

Check box if product is a Restricted Use Pesticide.

4. Manufacturer name if applicable.

Manufacturer name can be added to the drop-down menu by pressing .

5. Press  to enter a unique name for the product.

Created product will appear under the Application heading located on the Product tab of the Configuration Setup screen.



**NOTE!:** Some Fertilizer and Carrier product types are predetermined in the display. These product names cannot be edited. Their Manufacturer and EPA Numbers can be edited after the product is created.

Examples are: Fertilizer  DAP or Carrier  30% UAN.

---

## Creating Product Template

Product Templates are set up by using the on-screen wizard.



**NOTE!** Prior to making a new product template, it is recommended to add the individual products to the list in the units recommended by the chemical label.

It is recommended to create product templates that contain the products applied for a crop type or time of the season.

Examples are:

- Pre-Emerge Burndown
- Post-Emerge Corn
- Post-Emerge Beans
- Insecticide
- Fungicide

In each template the products can be checked on/off for the mix when loaded at the run screen.



### 1. Select Tank Mix

Define By

- Total amounts - mix/blend defined by amounts added to the tank (total of each product in tank)
- Rate/acre - mix/blend defined by the amounts applied per acre (rate of each product applied/area)

### 2. Enter a Base Amount or Base Rate and Units.

- Total Amounts - Tank/Bin Size
- Rate/Acre - For Rate Applied per Acre



### 3. Select Carrier



- Press  to create a new carrier.

4. Press  by the Add Mix/Blend Contents box to start the process of adding components to the mix.
5. Select the desired component from the drop-down menu.





**NOTE!:** More than 7 products can be part of a template, but only 7 or fewer can be active at the same time.

- A new product can be set up at this time by pressing  and following the Product Setup Wizard.
- Press  to add selected product, or press  to return to Add Mix/Blend screen without adding a product.

6. Press  to add an additional product.
7. When all components have been added press .
8. Enter Manufacturer name if applicable.

•Manufacturer name can be added to the drop-down menu by pressing .

9. Press  to enter a unique name for the mix/blend.

- Press  to complete the process of setting up the mix/blend, or press  to return to the Configuration Setup screen without adding a mix.

The product mix/blend appears under the Application heading located on the Product tab of the Configuration Setup screen.



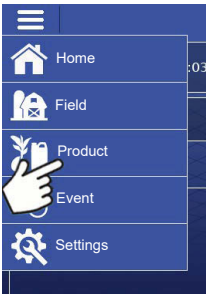

Represents Product Templates

# Configure Product Mix

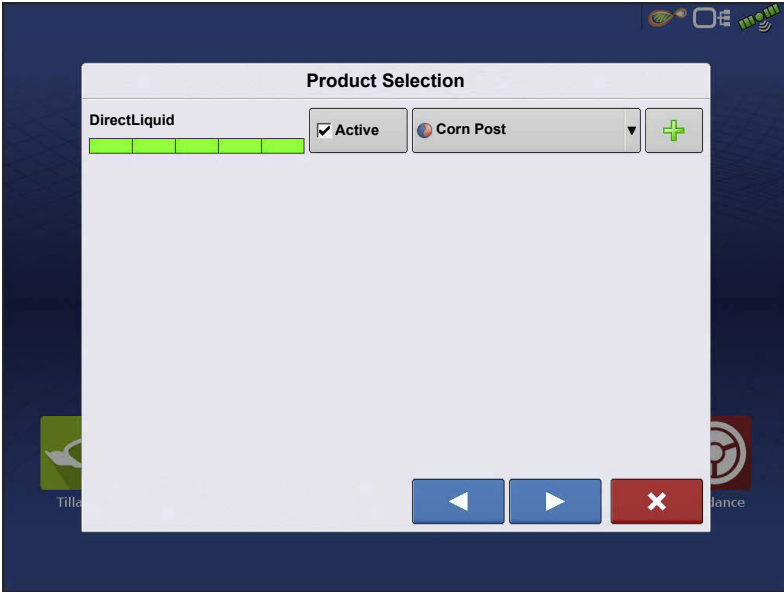

When using a product template, the mix contents and amounts are defined in the Configure Product Mix screen available in the Event Setup Wizard, or Product button in the main menu.



1. Select mix/blend from the dropdown list or press  to create a new mix/blend.

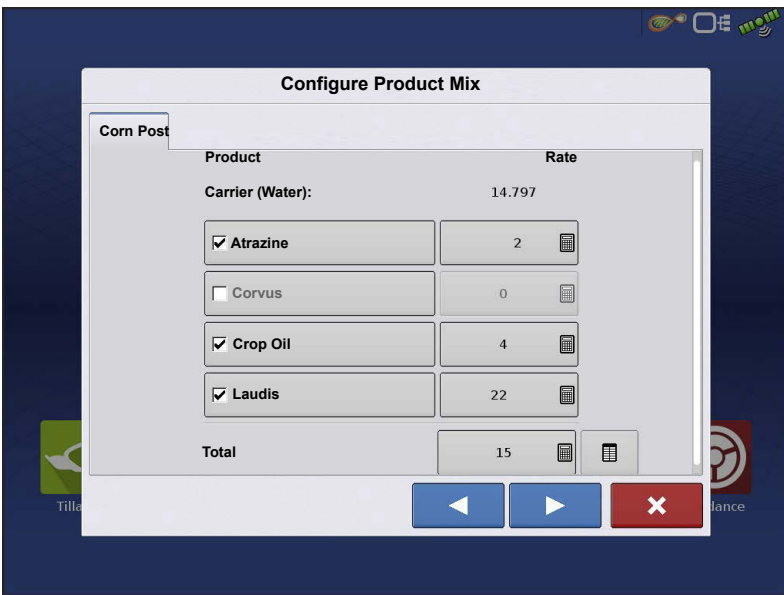

2. The product template mix contents and amounts are defined by:

- a. activating or deactivating products
- b. changing rate or total amount of product
- c. changing total amount of the product or overall rate of product application

A product cannot be active with a rate of zero. Press  to access the Mix Calculator.

3. When a product template is setup using rate/area, the Mix Calculator can be used to show how much of each product to put in the tank when the user enters the desired amount to fill.



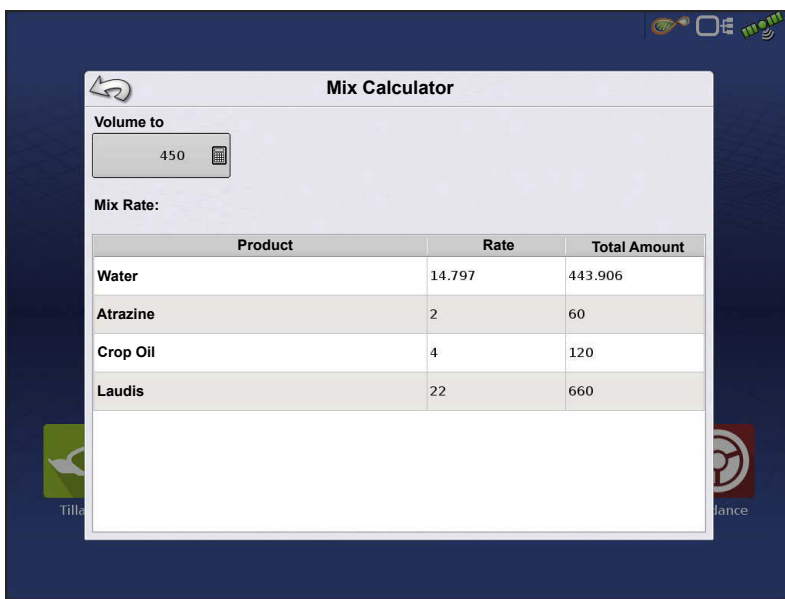

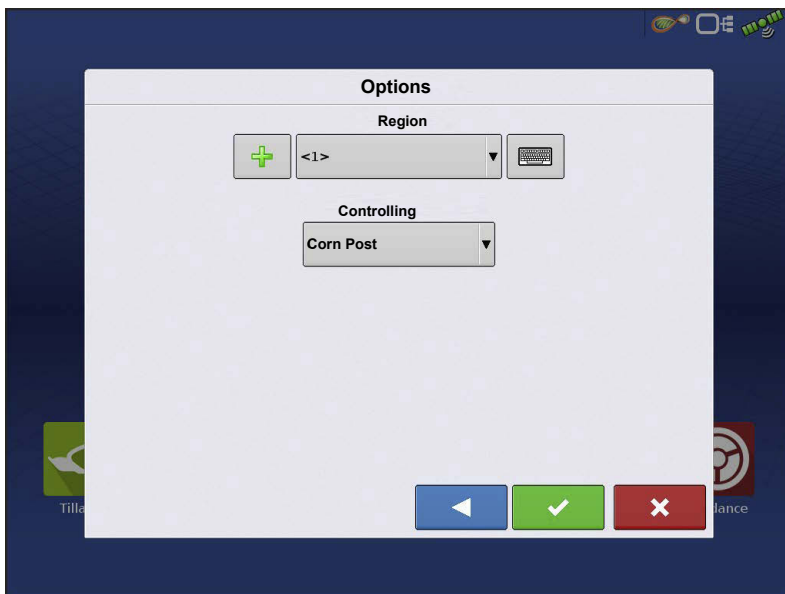

4. Press the Volume to Calculate button and input the total volume. Table will give the user the amount of each product to put in the tank.



5. Select Region from the drop-down menu or press  to name region.

Verify the Controlling Product for the Mix/Blend.

Press  to load the Event to the Map Screen, or press  to return to Home screen without setting up an Event.

## Create Configuration

A wizard will step through the process of selecting or creating a configuration with application settings.

Press:

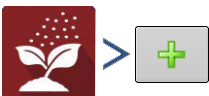

OR

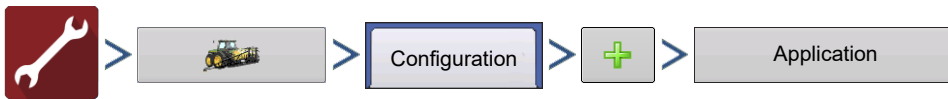

Operating Configuration will be viewable when starting a new Field Operation with the Application Wizard.

**Manage Equipment** button can also be used to create or edit specific vehicles and implements.

## Implement Offsets

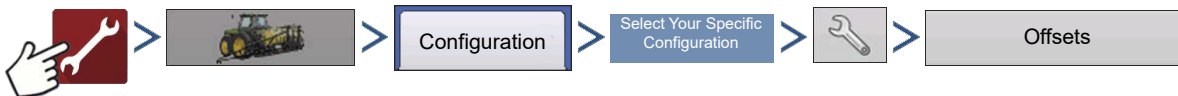

OR

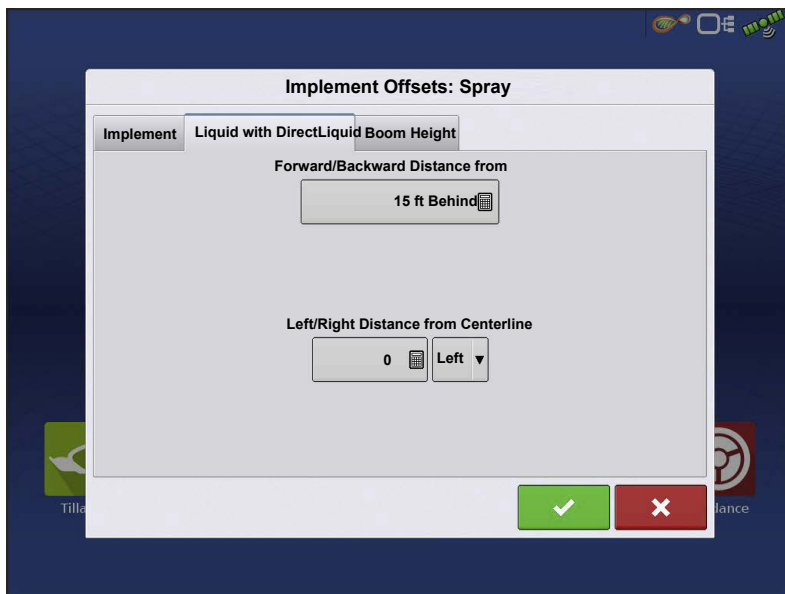

Implement Offsets screen appears, with each channel's settings shown on its own tab.

Defaults to the value entered during Configuration Wizard.

Boom sections can independently be offset forward or back (Application Operation Only).



Swath Section Offsets screen.

# DirectCommand® L2 Rate Controller

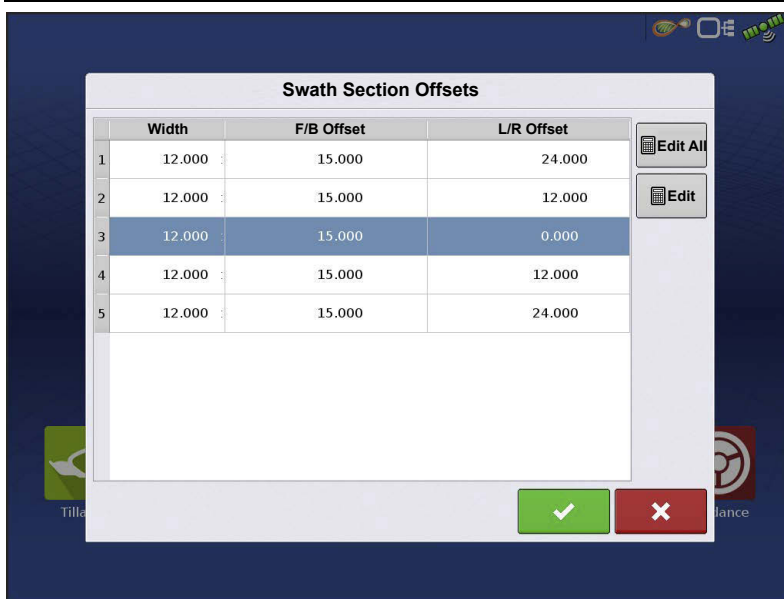

1. Select Swath section to edit and press Edit button.
2. Enter Offset for that specific section and Forward/Backward from rear axle.

3. Press  to enter change.

Setup will indicate which offset is entered

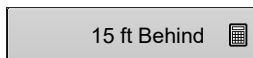

**Global**—All sections have the same offset.



**Individual**—At least one section has a different offset.

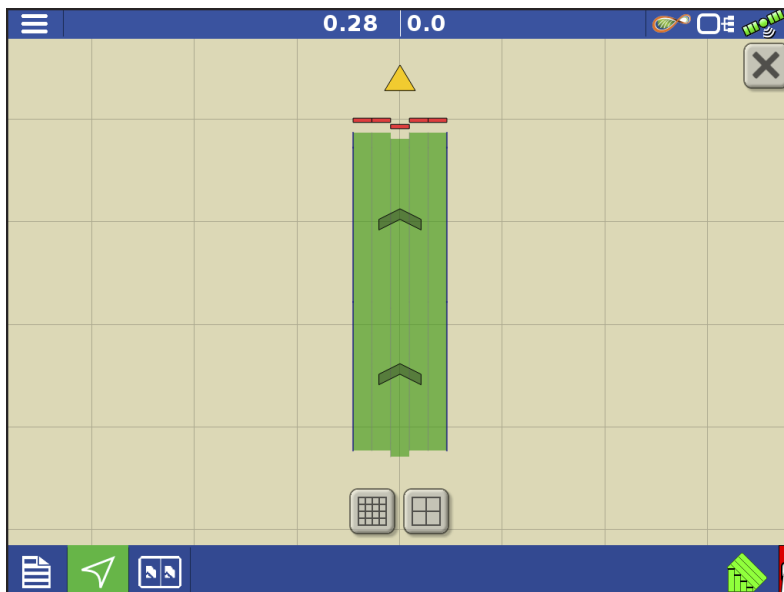

Runscreen reflects section offsets

# Equipment Settings

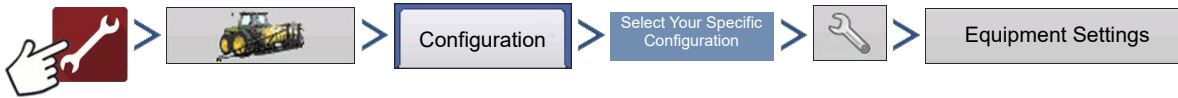

OR

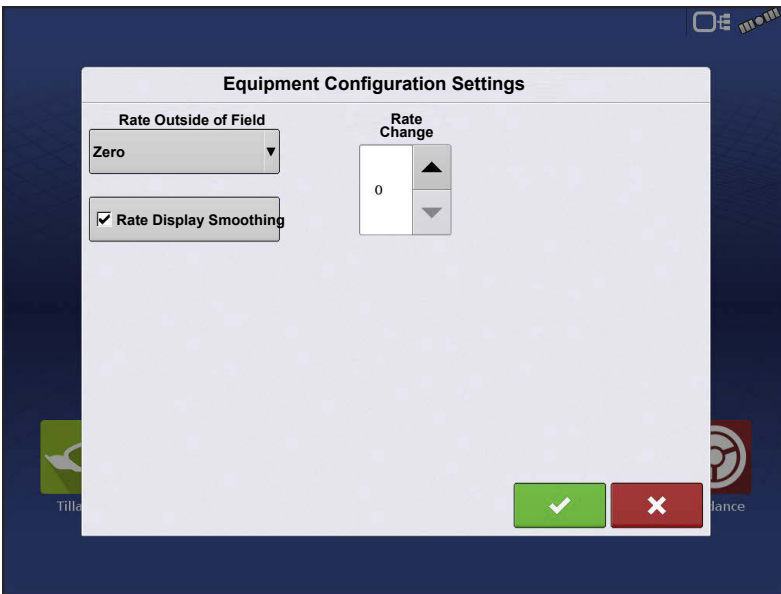
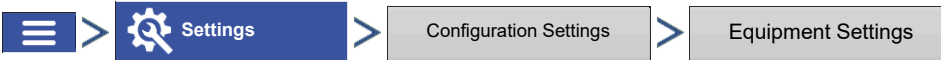

**Rate Outside of Field**—This setting will define how product will be controlled when leaving a field boundary.

- Zero**—This will stop application.
- Last Good**—This will continue application at the last known rate.
- Rx Default**—When using a prescription, this will apply at the Default Rate (or outside of boundary rate) as defined by the prescription file.

**Rate Display Smoothing**—Determines how the feedback from the control channel rate sensor will be displayed on the map screen. When not selected, the system will display raw feedback from the rate sensor. When checked, the system will display target rate when the application rate is within 10% of the target rate setting.

**Rate Change Look-Ahead**—This setting compensates for any latency in the control system when changing between different product flow rates during variable rate application. The typical setting range for this is 0-1 seconds. This setting can be thought of as a “look ahead” value when using a variable rate prescription. The display will send the signal to change rates before hitting a transition line so that the applied rate is correct when crossing into the new management zone.

## Auxiliary Input

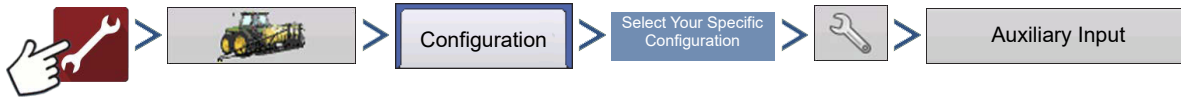

OR

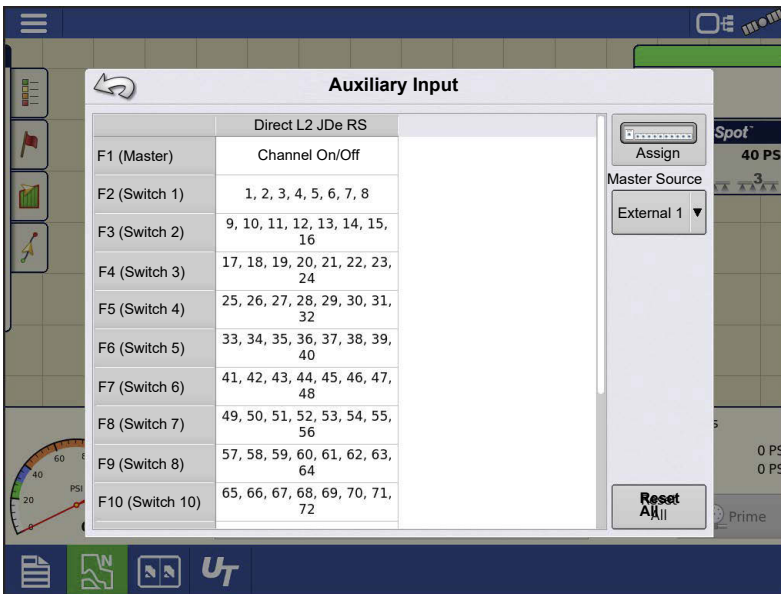

DirectCommand applications default boom sections to the switchbox in order, starting with switch 1. From the Auxiliary Input screen, the operator can customize the switches to the boom sections, if desired; or assign left/right fence row nozzles.

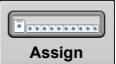
1. Press 
2. Highlight the desired switch to assign a function to it.



3. Select appropriate function(s) (boom sections for this operation) to assign to the desired switch. Chain icons within each function will "link" once pressed to indicate they are assigned. If a function has a "broken link" then it is not assigned. If a switch has an "X" then it is not assigned to a function. Press  to save the setup.

 **NOTE!:** Even if no specific functions are assigned to the Master Switch, the Master Switch will still serve as the total system on/off switch.

### Fence Row Nozzle Indicators

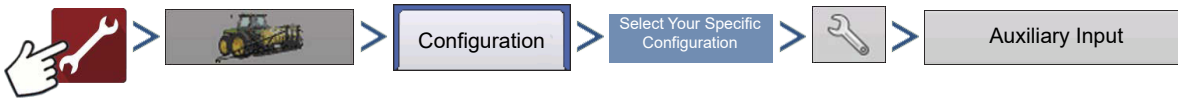

Control fence row nozzles through the DirectCommand system by mapping the switches in Auxiliary Input Settings. Fence row nozzles can be mapped to any switch. After specifying Fence Row Nozzle settings at the Auxiliary Input Assignment screen, the **Fence Row Nozzle Indicators (A)**, which are shaped like triangles, appear on either side of the sections behind the vehicle

icon.



**NOTE!:** If a switch is selected as a left or right fence row nozzle, the system sends power from the last swath module out of pin 11 for the left fence row nozzle, or pin 12 for the right fence row nozzle, for a 12V signal valve. When using polarity reversing valves, the left fence row nozzle is controlled by pins 9 and 10 and the right fence row nozzle is controlled by pins 11 and 12. When using polarity reversing valves, the left fence row nozzle is controlled by pins 9 and 10 and the right fence row nozzle is controlled by pins 11 and 12.



**NOTE!:** The boom sections next to the fence row nozzles must be turned on before the fence row nozzle can be turned on.



**NOTE!:** If multiple swath modules are needed for operation, left and right fence row nozzles are assigned to the last swath module with the same pin assignment stated above.

# Implement Modeling

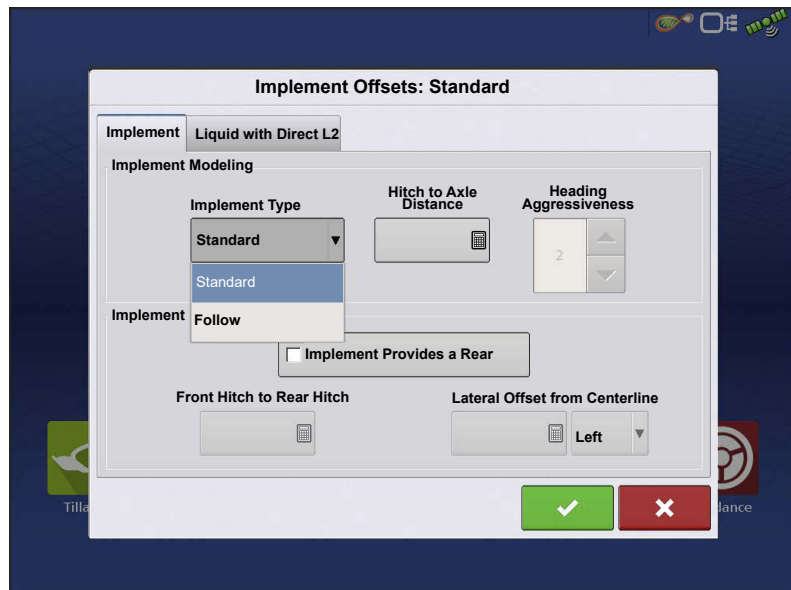
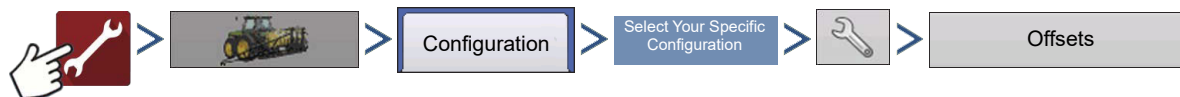

When using implement modeling, implement type can be set to Standard or Follow. This selection adjusts how the display models the path of the trailed implement.

If a trailed implement utilizes a steerable axle, the Follow feature can be used.

## • Heading Aggressiveness

The Heading Aggressiveness setting can be used to fine tune mapping of a trailed implement that has a steerable axle or wheels. The setting ranges from 0 - 10. The default value is 2.

An aggressiveness setting near 0 or 1 will model an implement that follows the path of the vehicle.

As the aggressiveness setting is increased, the modeling resembles an implement that steers outside the path of the vehicle. The modeling becomes more exaggerated the closer the setting is to 9 or 10.



## Liquid Application Controller Settings

### Controller Settings

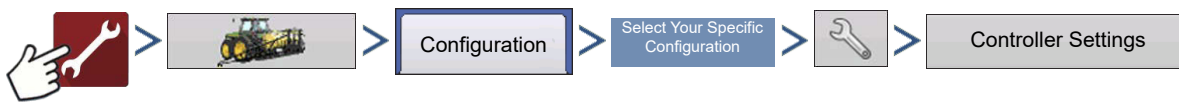

OR



### Control Feedback

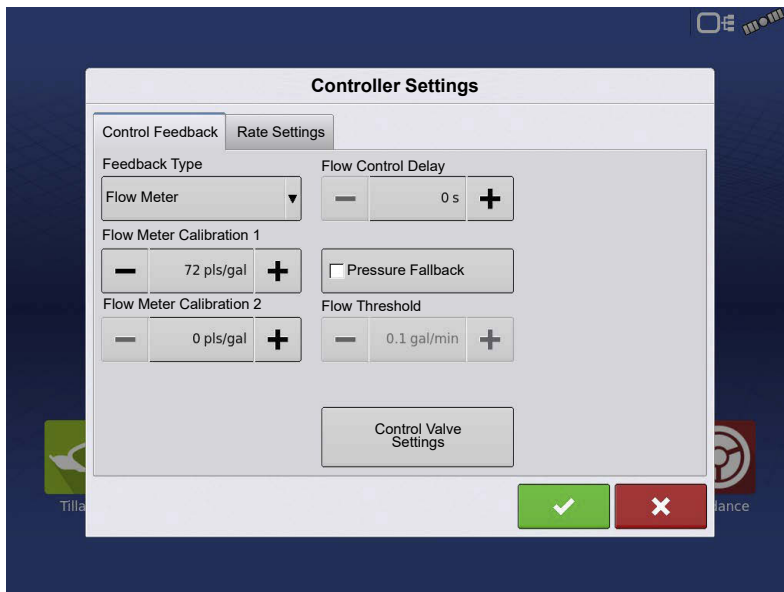

**Feedback Type** – Select the sensor type being used. Flow meter or Pressure Sensor.

**Flow Meter Calibration 1** — Calibration value representing the number of pulses that equal one gallon of product flow through the controlling system. This value can typically be found on the flow meter tag. For Raven flow meters, divide this value by 10 before entering it in the

display.

**Flow Meter Calibration 2** — This only needs entered if your system has two flow meters. Calibration value representing the number of pulses that equal one-gallon of product flow through the controlling system. This value can typically be found on the flow meter tag. (For Raven flow meters, divide this value by 10 before entering it in the display.)

**Flow Control Delay** — Specifies the time delay from a commanded rate on to when the system actively begins flow control based on flow sensor feedback. This setting can be used to eliminate unwanted correction of flow control at the start of each pass. For RightSpot, typical values for flow control delay are 0-1 second.

**Pressure Fallback** – Pressure Fallback is a setting that allows the system to automatically switch between flow based and pressure based control. Pressure Fallback is beneficial in low flow situations where a flow meter may be less accurate or not provide the necessary resolutions to provide reliable flow control. In flow rates below the user defined Flow Threshold, the system will transition to Pressure Fallback and utilize pressure sensor feedback for flow control. Both a flow meter and a pressure sensor must be present on the machine to use Pressure Fallback.

**Flow Threshold** — Set the range of flow that will tell the system to switch between flow based or pressure based control. For example, setting the threshold to 10 gallons/minute will result in the system using the flow meter when flow is greater than 10 gallons/minute and using the pressure sensor when flow is less than 10 gallons/minute.

**Control Valve Settings** — Opens the Control Valve Settings screen, which displays control valve settings for PWM, Servo, Calibrated Reflow and Ramsey Valve Controls.

## Rate Settings

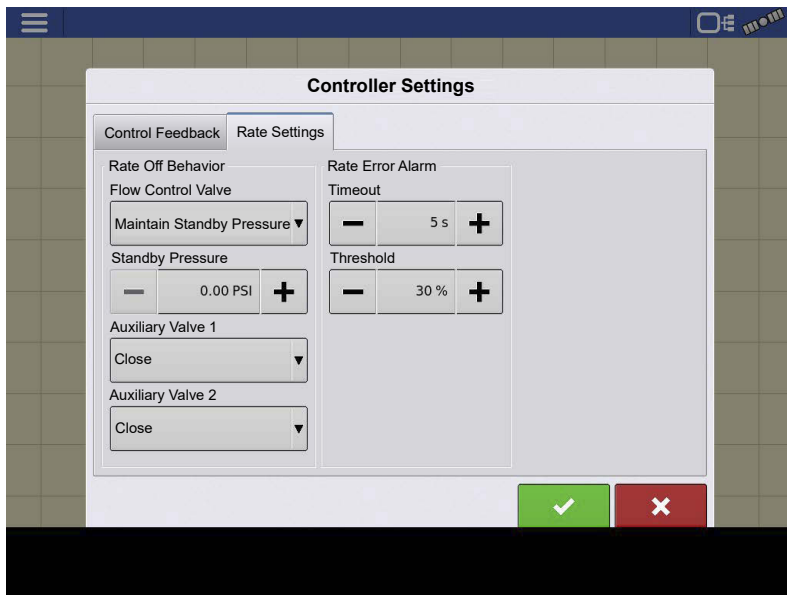

### Flow Control Valve

A. Hold: The product control valve remains in the last known state when all sections are shut off.

B. Close: The flow control valve shuts down when there is either a zero rate in the field or when entering an already-applied area.

C. Maintain Standby Duty Cycle: The controlling system remains in the Standby Duty Cycle set in the control valve settings for PWM Standby.

D. Maintain Standby Pressure: The flow control valve achieves the Standby Pressure defined by the user.

**Auxiliary Valve 1 & 2** —When all boom sections are off, this setting closes or opens an auxiliary valve. Choose settings for up to two auxiliary valves.

**Threshold** —The user-defined percentage of actual rate error allowed before an alarm sounds.

**Timeout** —The number of seconds that an actual rate falls out of the error threshold before an alarm sounds.

## Control Valve Settings - PWM

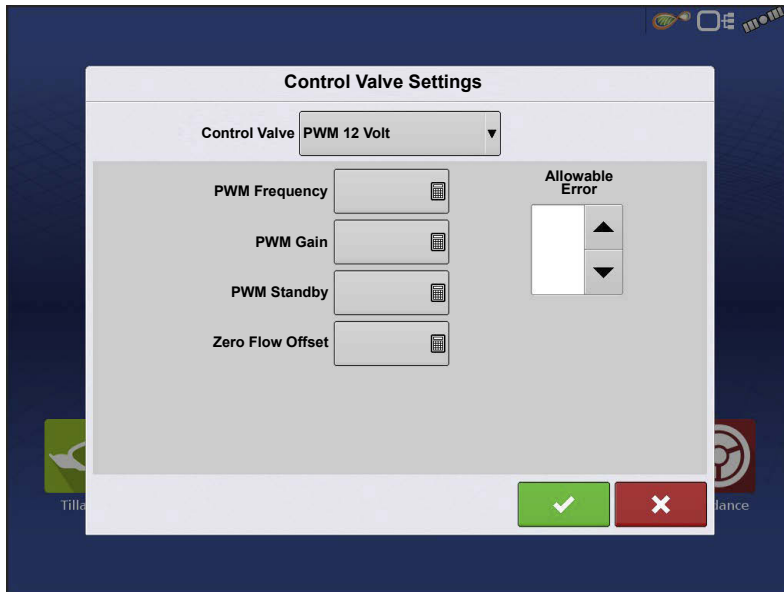

**PWM Frequency** — Settings determined by the manufacturer of the valve. Default Value is 100. Typical settings range from 100-125 Hz.

 **NOTE!**: See PWM valve manufacturer information for recommended settings.

**PWM Gain** — Determines how aggressively the control valve responds when making rate or pressure change adjustments. The higher the value the more aggressive the system response is. Default Value is 800.

**Zero Flow Offset** — Represents the maximum duty cycle that is sent to the control valve without producing any hydraulic flow from the PWM valve. Using too high of a Zero Flow Offset value can cause the product control system to not properly control low rates or shut off. Default Value is 30. See the PWM valve manufacturer information for recommended settings or use the PWM tuning tool to determine the correct zero flow offset.

**PWM Standby** — This is a user-defined setting that determines the percent duty cycle the system uses when the boom sections are all off. The setting must be greater than the Zero Flow Offset.

**Allowable Error** — This maximum allowable error before the control valve commands a change in flow.



**NOTE!** The current PWM Duty Cycle can be viewed at the Liquid Diagnostics screen.

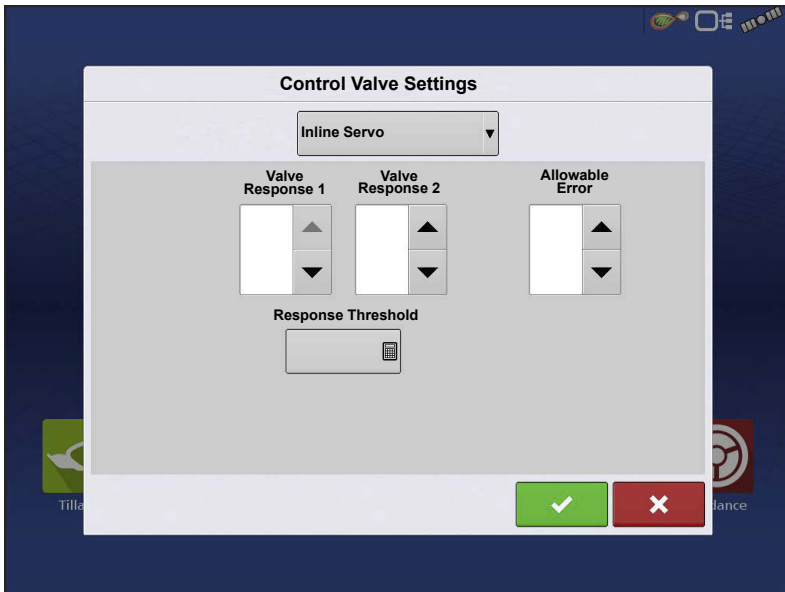

**Valve Response 1** — Determines the speed of the servo valve when product control error exceeds the Response Threshold setting. The default for this setting is 100%. Decreasing the value will cause the servo valve to run slower. Valve Response 1 represents the fast speed of the servo valve.

**Valve Response 2** — Determines the speed of the servo valve when product control error is less than the Response Threshold setting. The default for this setting is 24%. Decreasing the value will cause the servo valve to run slower. Valve Response 2 represents the slow speed of the servo valve.

**Response Threshold** — Determines where the control channel switches between using Valve Response 1 and Valve Response 2 speed settings. The default setting is 3. Leaving all other valve control settings at the default value and making a small adjustment to this setting is usually all that is required to fine-tune system performance.

- Decreasing this value will have the overall effect of speeding up servo valve response.
- Increasing this value will have the overall effect of slowing servo valve response.

## Container Level Settings

When filling or emptying container, use the Container Level portion of the Rate Control Settings screen to update the amount of product in the containers.

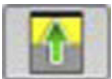

**Tank Fill** — The Tank Fill button increases the container level logged in the display to the user-defined maximum volume (specified in the Container Setup Wizard).



**Tank Empty** — The Tank Empty button decreases the container level logged in the display to zero.



**Tank Partial Fill** — The Tank Partial Fill button changes the container level logged in the display to specific amount specify by pressing calculator icon. Pressing the Partial Fill button summons the Adjust Container Amount screen.

## Adjust Container Amount

- **Add** — Adds product to the container.
- **Remove** — Removes product from the container.
- **Set** — Sets the product level in the container.

## Adjust Container Amount

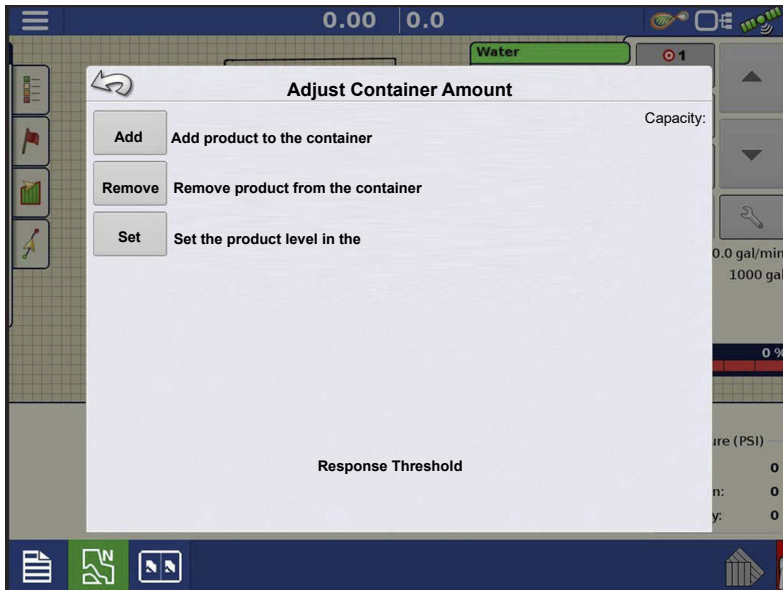

- **Add** — Adds product to the container.
- **Remove** — Removes product from the container.
- **Set** — Sets the product level in the container.

## Tank Alarms

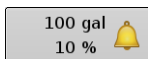

The Container Alarm button, which appears on the right of the Container Level portion of the Rate screen, displays the capacity of the tank as well as the percentage at which the Low Container Level warning will sound. To adjust these settings, press the button and the Container Alarm screen appears.

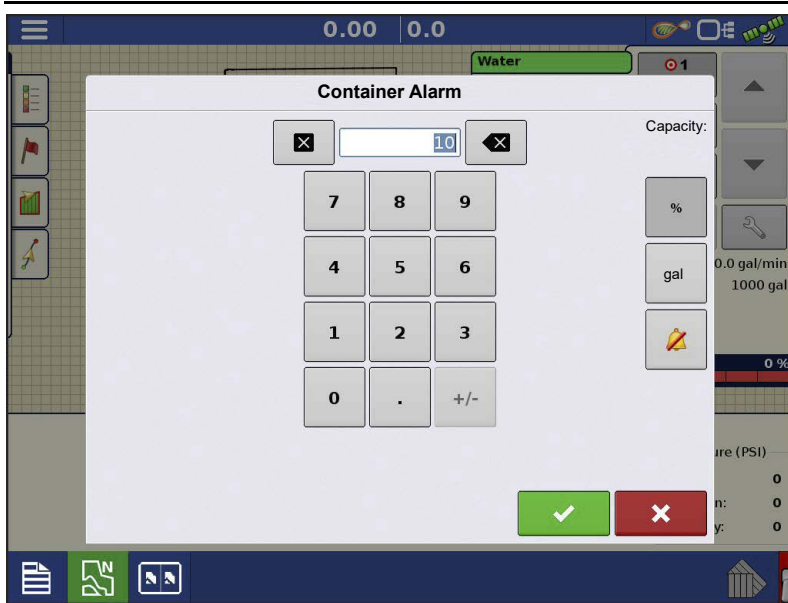

Adjust container level warnings using the following buttons on the right-hand side of the Container Alarm screen.

The **percentage (%)** button sets the warning threshold according to the percentage of solution left in the tank. In the example, to the left, the threshold is set at 10 percent.

The **units of measurement** icon sets the warning threshold according to the amount of solution left in the tank. This icon is named according to the container's units of measurement specified during the Controller configuration procedure.

The **Disable Low Container Level** button, which appears as a bell with a red slash across it, disables the Low Container Level warning.

## Liquid Application Diagnostics



To go to the Liquid Diagnostics screen, press



At the Devices screen, highlight the item marked **DirectCommand L2 module** then press the **Diagnostics** button.

The L2 Diagnostics screen includes the Module Power, Sensors, Control Valve State, Auxiliary Valve State, Implement Switch, and Agitation Valve.

## Control Valve:

### PWM Valve

- **Open** – The Open graphic will indicate the active commanded duty cycle
- **Closed** – The Closed will remain zero

### Servo Valve

- **Open** – The Open graphic indicates what the system is commanding the product control valve to open.
- **Closed** – The Closed graphic indicates what the system is commanding the product control valve to close.

### Auxiliary Valves

- **Aux 1** – Displays the state of the valve
- **Aux 2** – Displays the state of the valve
- **Implement Switch** – When Dot is green it is not available.

## Module Power:

- **ECU** – Displays voltage at the ECU
- **High Power** – Displays voltage of the main power source
- **Sensors:**
  - **Main Pressure** – Displays voltage of the Main pressure sensor.
  - **Aux Pressure** – Displays voltage of the Auxiliary pressure sensor.
  - **Agitation Pressure or Temperature** – Displays voltage of the pressure or temp sensor
  - **Flow meter 1 and 2** – Displays the current frequency generated by the flow meter during application. Provides a running pulse count of the flow meter during application. Helpful to monitor feedback to the system from the flow meter.

# Vehicle Interface Diagnostics

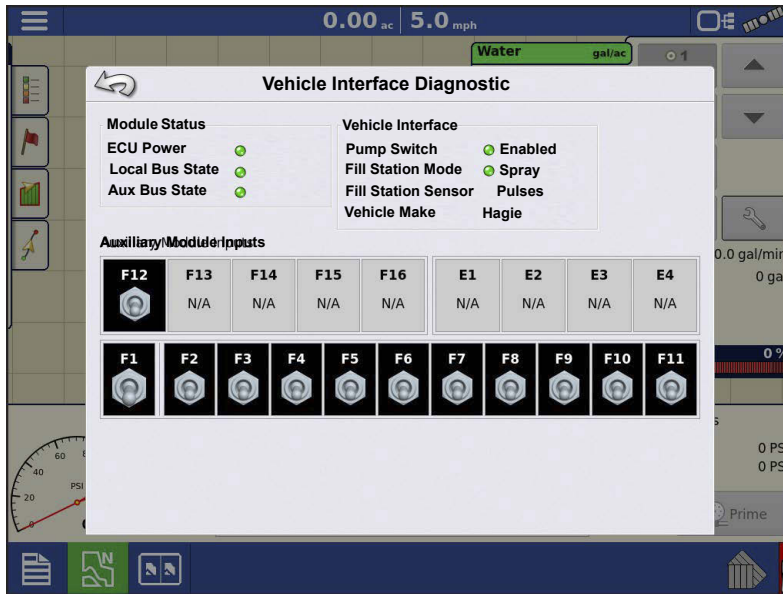

To go to the Vehicle Interface Diagnostics screen, press



 **NOTE!:** Vehicle Interface Module (VIM) is not required for every machine.

**ECU Power:** Indicates the voltage from the VIM module.

- Green – 10V and higher
- Yellow – 9.9 and lower

**Local Bus State:** Indicates Local Bus communication

- Green – Communication present
- Red – No Communication
  - Check Cabling
- Yellow - Passive – No communication from the VIM to auxiliary module if present
  - Check Cabling

**Aux Bus State:** Indicates Auxiliary communication

- Green – Communication present
- Red – No Communication
  - Check Cabling
- Yellow - Passive – No communication with the VIM
  - Check Cabling

**Pump Switch:**

- Green – Pump Switch Enabled
- Yellow – Pump Switch Disabled



## Fill Station Mode

- Green – Spray
- Yellow – Fill

When in Fill mode an alarm will also sound, indicating Fill Station is in fill mode.

## Mode:

- Red – Indicates switch box is unknown
- Green – Indicates switch box is known. It will also display the brand. (Ex, Hagie – indicating the Hagie Hydro Handle is the controlling switch box)

## L2 Liquid Rate Controller

### High Current LED

Status	Definition
Off	No Power
Solid Red	Low Voltage
Solid Green	Power OK

### LED 1– Local CAN Communication

Status	Definition
Off	CAN Bus Idle
Solid Red	CAN Bus Off
Solid Yellow	Passive BUS Error when no other devices are acknowledging.
Blinking Yellow	Active BUS Error when other devices are transmitting/receiving.
Blinking Green	Local CAN Bus Communicating with swath module

### LED 2– CAN Communication

Status	Definition
Off	CAN Bus Idle
Solid Red	CAN Bus Off
Solid Yellow	Passive BUS Error when no other devices are acknowledging.
Blinking Yellow	Active BUS Error when other devices are transmitting/receiving.
Blinking Green	CAN Bus Communicating

---

## Liquid Swath Module

### High Current LED

Status	Definition
Off	No Power
Solid Red	Low Voltage
Solid Green	Power OK

### LED 1 – Local CAN Communication

Status	Definition
Off	CAN Bus Idle
Solid Red	CAN Bus Off
Solid Yellow	Passive BUS Error when no other devices are acknowledging
Blinking Yellow	Active BUS Error when other devices are transmitting/receiving
Blinking Green	Local CAN Bus Communicating with L2 Rate Controller

### LED 2 – Local CAN Communication

Status	Definition
Off	Standard Working State

## Troubleshooting DirectCommand L2 Applications

**Problem:** Boom indicators on the run screen of the display do not turn green.

**Solution:**

1. Make sure ground speed is registering a value greater than zero on the display.
2. Verify a target rate greater than zero is entered into the display.
3. Check the switch status found on the run screen under CAN and Input Diagnostics. As the boom switches are turned on and off, the Input Diagnostics window should change from black to green (if they do not, then refer to the installation instructions to verify boom switch connections).
4. Check high current connection into the L2 Rate Control Module.
5. Turn AutoSwath off.

**Problem:** Boom indicators on the run screen of the display turn green, but the booms do not open.

**Solution:**

1. Check wiring connections for all of the boom valves.
2. Verify that the cabling is providing 12 volts to the boom valve on the signal pin.

**Problem:** AutoSwath turns on the boom too fast or too slow.

**Solution:**

1. Check GPS offsets in the vehicle setup to verify all the measurements are correct.
2. Verify implement offsets are appropriate for the sprayer.
3. Adjust the turn on look-ahead and turn off look-ahead to fine-tune Automatic Swath Control performance.
4. Verify Forward/Backward Section Offsets. If applicable - verify Section Offsets are correct if boom section(s) are independently offset.

**Problem:** No “As Applied” rate Solution:

**Solution:**

1. Check cabling from the channel connection of the L2 Rate Control Module to the flow meter.
2. Check flow meter for product buildup and proper operation.

**Problem:** Rate is erratic Solution:

**Solution:**

1. Verify that the rate display smoothing option is check marked in the Equipment Settings of the Configuration Setup.
2. Check the controller settings of the active configuration. Verify that the valve settings are appropriate for the particular type of control valve being used.
3. Use manual valve control to see if the rate stays constant.

**Problem:** Erratic behavior from the flow meter and boom valves.

**Solution:**

1. Verify that the display firmware and module firmware are both current.
2. Verify that cabling has been installed correctly and that none of it has been pinched or damaged.

**Problem:** No boom pressure at the start of the field.

---

**Solution:**

1. Before product application begins, select Boom Prime and flip master switch on when ready to apply, or use manual valve control to build boom pressure. Select either Rate 1 or Rate 2 once pressure is set to desired level. Enter the pass and allow automatic control to take over once the sections are turned on.

**Problem:** AutoSwath checked on, but booms will not turn on.

**Solution:**

1. Make sure the ground speed is registering a value greater than zero on the display and not in previously covered area.
2. Make sure there is a target rate greater than 0.
3. Make sure the applicator is inside of the field boundary.
4. Verify the Master Switch icon is indicating On (green) and Off (red) appropriately.

**Problem:** Booms turn off in the middle of the pass.

**Solution:**

1. Check the display firmware and module firmware to see if they are the latest version released.
2. Make sure the ground speed does not go to 0.
3. Make sure the GPS is not losing the differential source.
4. Verify that cabling has been installed correctly and that none of it has been pinched or damaged.

**Problem:** Rate not responding (error flashing)

**Solution:**

1. Make sure the flow meter calibration number matches the tag on the flow meter. For Raven flow meters, divide the calibration number by 10.
2. Make sure that the flow being applied is not greater than the pump can produce.
3. Use manual valve control to see if the control valve will open or close.
4. Check the tip manufacturer's charts to make sure they are in the operating range of the application.

5. Check for any product buildup in the flow meter.
6. Check product filter for debris.

**Problem:** Booms turn on when outside of the boundary.

**Solution:**

1. Make sure the Rate Outside of Field option is set to zero under the active configuration settings.
2. Make sure the Outside Boundary Option is set to Turn Section Off under the Automatic Swath Control options.
3. Make sure there is not a gap between the boundary and the first pass of the headlands.

**Problem:** Booms turn on briefly (less than a second) in the headlands (previously covered area)

**Solution:**

1. Make sure that the turn on look-ahead is greater than the turn off look-ahead.
2. Make sure GPS offsets are correct.
3. Make sure look-aheads are less than three seconds each.
4. Verify that the display and liquid control module are both updated to the latest available firmware.

## Control Valve Settings

### Liquid Product Control Valve Configuration Options

**Inline Servo** — Rate control is achieved through actuating a butterfly or ball valve found in the solution hose that goes to the booms. When the valve opens, the flow increases and when the valve closes, the flow decreases.

**Bypass Servo** — Rate control is achieved through actuating a butterfly or ball valve found in the return line to the solution tank. When the valve opens, the flow decreases and when the valve closes the flow increases.

**PWM 12 volt** — Rate control is achieved through speed changes to the solution pump. The PWM 12 Volt setting is programmed to pulse the power to an electric solenoid valve used to adjust the hydraulic flow to the solution pump.

---

**Pump Servo** — Rate control is achieved through speed changes to the solution pump. The pump servo setting is programmed to control an electric motor used to actuate a hydraulic valve to adjust the hydraulic flow to the solution pump.

**PWM Ground** — Rate control is achieved through speed changes to the solution pump. The PWM Ground setting is programmed to pulse the ground to an electric solenoid valve used to adjust the hydraulic flow to the solution pump.

**Calibrated Reflow** — Three-way boom valves are used to return product back to the tank in the off state. The returned flow is calibrated with adjustment at each valve. Calibration is required any time the nozzles are changed.

**Ramsey Valve** — A pneumatically-operated bypass valve. When air is supplied to the valve the rate increases; when air is released from the valve the rate decreases.

## Dickey-John NH3 Conversions

### Conversion Formulas

The following formulas can be used to convert the Dickey John flow sensor constant to a value that represents pulses/gallon of anhydrous ammonia for use by the display.

Formula for flow meter calibration for Dickey John reading pounds of anhydrous.

$$\frac{\text{Flow sensor constant (pulses/in}^3) \times 1728 \text{ (in}^3\text{/ft}^3) \times 5.11 \text{ (lbs of anhydrous/gal)}}{\text{Density (lbs. of anhydrous/ft}^3)}$$

Formula for flow meter calibration for Dickey John reading pounds of Nitrogen.

$$\frac{\text{Flow sensor constant (pulses/in}^3) \times 1728 \text{ (in}^3\text{/ft}^3) \times 4.22 \text{ (lbs of N/gal)}}{\text{Density (lbs. of N/ft}^3)}$$



**NOTE!:** The flow sensor constant is tagged on the Dickey John flow meter. The density setting comes from a chart in the Dickey-John documentation and is not provided in this user guide.

## Fertilizer default Product Settings

Material	Type	Abbreviated name for display and predefined name for SMS™	Percentage (in terms of lbs. 100 lbs.)			Density
			N	P(P <sub>2</sub> O <sub>5</sub> )	K (K <sub>2</sub> O)	
Anhydrous Ammonia	Liquid under pressure	NH <sub>3</sub>	82	0	0	5.14 lbs./gal. (at 60°F)
28% UAN	Liquid	28% UAN	28	0	0	10.67
30% UAN	Liquid	30% UAN	30	0	0	10.86 lbs./gal.
32% UAN	Liquid	32% UAN	32	0	0	11.06 lbs./gal.
Ammonium polyphosphate (starter)	Liquid	Ammonium polyphosphate	10	34	0	11.73 lbs./gal.

## Glossary of Application Settings

### Configuration Settings

**Rate Outside of Field**—Rate that will be used outside of the field boundary. **Zero** stops product application. **Last Good** uses the previous rate before exiting the boundary. **Rx Default** uses the default rate written in the prescription file loaded.

**Rate Display Smoothing**—Determines how the feedback from the control channel’s rate sensor will be displayed on the run screen. When checked, the system will display the target rate when the application rate is within 10% of the target rate setting. When unchecked the system will display the raw feedback from the rate sensor.

**Minimum Flow**—This setting is used to maintain a consistent spray pattern. The display will not allow flow to drop below the entered setting. Set to flow at the lowest operating pressure for the selected spray tips with all sections on. When spraying with one or more boom sections off, the system automatically reduces the minimum flow setting according to the reduced spray width.

**Rate Change Look-Ahead**—Compensates for any delay in the control system when changing between different product flow rates during variable rate application. This setting can be thought of as a “look ahead” value when using a variable rate prescription. The display will send the signal to change rates before hitting a transition line so that the applied rate is correct when crossing into the new management zone. The typical setting range for this is 0-1 seconds.

---

## Speed Input Settings

**Primary Speed Source**—Main speed input source used by the display.

**Backup Speed Source**—If the primary speed source fails, the display will use the backup if one is available.

**Manual Speed**—If both of the speed input sources are unavailable, manual speed can be used in order for the control channel to provide application. Manual speed setting is for use during static machine testing or by the control system in the absence of primary and backup speed signals.

## Automatic Swath Control Settings

**Turn-On Look-Ahead**—Determines how far ahead the system looks to turn the swath sections back on. This setting compensates for any delay in the product control system when the sections are turned on.

**Turn-Off Look-Ahead**—Determines how far ahead the system looks to turn the swath sections off. This setting compensates for delay in the product control system when the boom sections are turned off.

**Outside Boundary Option**—Determines the behavior of the sections when exiting the field boundary or prescription-mapped area.

**Coverage Option**—Based on the coverage option selected, this setting determines the behavior of the swath section when entering/exiting an already applied area or field boundary. Options available include: Minimize Skip, Minimize Overlap, and User Defined Percentage.

## Auxiliary Input Settings

**Master Source** — Switch that performs global master control of all rate control channels.

**F1-F11** — Settings determine the switch(es) that will operate the controlling channel specified from the configuration setup.

**Assign**—Screen where switch(es) can be assigned to specific controlling channels. Single switches can be used to control multiple channels and swath sections.



## Controller Settings

**Flow Meter Cal** — Calibration value representing the number of pulses that equal one-gallon of product flow through the controlling system.

**Control Valve Settings** — Setting specifies the type of control valve being used for the rate control functions of the controlling system.

**Response Threshold** — Determines where the control channel switches between using Valve Response 1 and Valve Response 2 speed setting.

**Valve Response 1** — Determines the speed of the servo valve when product control error exceeds the Response Threshold setting. Valve Response 1 represents the fast speed of the servo valve.

**Valve Response 2** — Determines the speed of the servo valve when product control error is less than the Response Threshold setting. Valve Response 2 represents the slow speed of the servo valve.

**Allowable Error** — Determines the percent of error that is allowed prior to the product control system making any flow rate changes.

**Flow Control Delay** — Setting for period of time from master switch on and the start of product application to the first flow control correction. This setting can be used to eliminate unwanted correction of flow control at the start of each pass. Typical setting values are zero for granular and 1 –2 seconds for liquid application control.

**Flow Control Valve**—When set to "Close" the controlling system shuts down when there is either a zero rate in the field or when entering an already-applied area. When set to "Hold" the controlling system remains in the last known state when all sections are shut off. If a PWM is the controlling system and the Flow Control Valve setting is set to "Hold" the valve will adjust to PWM Standby when all sections are shut off.

**Auxiliary Valve 1 & 2**—When all boom sections are off, this setting closes or opens an auxiliary valve. Choose settings for up to two auxiliary valves.

**PWM Frequency** — The frequency that the PWM control valve is pulsed at. Settings can be found from the manufacturer of the valve. Typical settings range from 100-125 Hz.

---

**PWM Gain** — Determines how aggressively the control valve responds when making rate change adjustments. The higher the value the more aggressive the system response is.

**Zero Flow Offset** — Represents the maximum duty cycle that is sent to the control valve without producing any hydraulic flow from the PWM valve. Using too high of a Zero Flow Offset value can cause the product control system to not properly control low rates or to shut off. See the PWM valve manufacturer information for recommended settings.

## Alarms

**Alarm:** Rate Not Responding

**Trigger Condition:** As-applied rate is outside user specified range for longer than user specified time

**Clear Condition:** As-applied rate is within “good” range

**Alarm:** Pressure Not Responding

**Trigger Condition:** Pressure is not within 10 psi for 5 seconds

**Clear Condition:** Pressure returns to within 10 psi

**Alarm:** Swath Module: High-Power Voltage Low

**Trigger Condition:** High Current power on swath module is below 10 volts

**Clear Condition:** High-Power returns to normal

**Alarm:** Liquid Control Disabled: Cycle Master Switch

**Trigger Condition:**

- Event is loaded and master switch is “ON” state

or

- System is controlling pump but pressure is not responding.

**Clear Condition:** Cleared when master switch is turned off.

## RightSpot™

RightSpot enables automatic nozzle-by-nozzle swath control while maintaining consistent rate, pressure, and droplet size at every nozzle. RightSpot can increase productivity, reduce overlap, and achieve consistent results throughout a broad range of speed, all while navigating challenging terrain such as contours and odd-shaped fields. Once a configuration has been completed, the Map View screen appears.

### Load Configuration



Press the Application App from the home screen to load a configuration.

### Map View

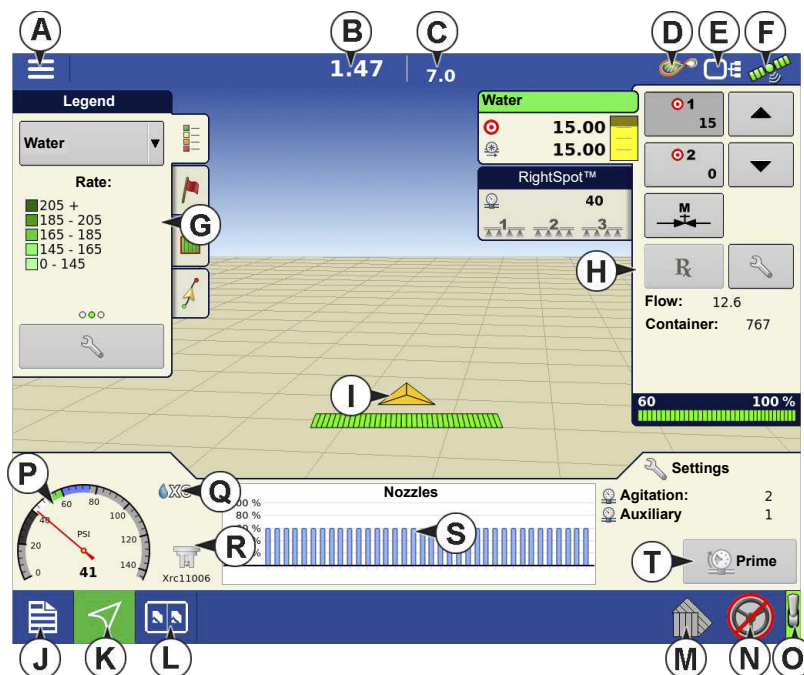

- A. Menu button
- B. Total Logged Field Area
- C. Ground Speed
- D. AgFiniti® Status
- E. Diagnostics
- F. GPS Signal Indicator
- G. Display Legend
- H. Product Control Toolbox
- I. Vehicle Icon
- J. Event Summary
- K. Map View
- L. Split Screen
- M. AutoSwath™ Indicator
- N. Guidance Indicator
- O. Master Switch Indicator
- P. Pressure Gauge
- Q. Droplet Size Indicator
- R. Nozzle Indicator
- S. Nozzle Bar Graph
- T. Boom Prime



**NOTE!:** Pressing the Map View button will cycle between the available Map screen views, and the appearance of the Map View button changes.

# Product Control Toolbox

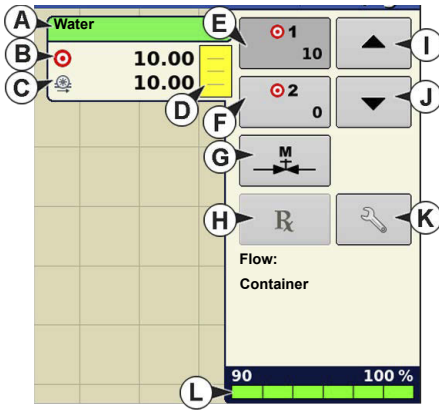

During DirectCommand™ Run Time operations, the Product Tabs are shown in the upper right-hand side of the Map screen. Press the Product Tabs, and an extended view shows the Rate buttons, Manual Valve Control button, Prescription button, Rate Increase and Rate Decrease arrows, and the Rate Setup button, all of which are described below.

- A. Product
- B. Target Rate
- C. Actual Rate
- D. Container Level
- E. Rate 1 button
- F. Rate 2 button
- G. Manual Valve Control
- H. Prescription button
- I. Rate Increase button
- J. Rate Decrease button
- K. Rate Control Settings
- L. Section Status Indicator



**Target Rate** — The Target Rate is desired application rate.



**NOTE!** In some conditions, the Target Rate may increment more quickly than the Actual Rate.



**Actual Rate** — The Flow Sensor returns the actual rate being applied.



**Container Level** — The Container Level shows the amount of product in the container.



**Rate 1 and Rate 2** — The Rate 1 and Rate 2 settings represent preset application rates that allow operators to quickly change between desired target rates for each individual product.



**Manual Valve Control** — When using RightSpot the manual valve control button allows operators to adjust the duty cycle of the nozzle valves. Operators can use this to prime the system before application, clean out equipment at the end of the day, or check the functionality of the valves.



**Increase and Decrease** — Increase/Decrease target rate and when in manual control they increase/decrease duty cycle of Nozzle Valve Assemblies.



**Prescription**



**Rate Control Settings** — Select the wrench to enter Rate 1 and 2, Increment, Minimum Flow, Prescription, and access to container settings.

## Boom Prime

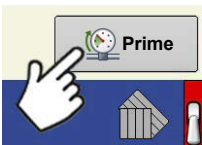

Boom Prime allows the boom to be pressurized with the master switch off prior to applying. To engage, select the Prime button in the bottom left corner of the run screen. To disengage select the boom prime button again or flip the master and begin applying.

The master switch must be off for Prime to be accessible. When Prime is selected with RightSpot, the boom valves will open providing pressure to the Nozzle Valve Assemblies.



**NOTE!** When using a Servo Valve, Rate Off setting must be set to Maintain Standby Pressure for Prime to be available.

# RightSpot Toolbox

During Runtime Operations with RightSpot, the RightSpot Toolbox is shown in the upper right hand side of the Map Screen. Press the RightSpot Tab and an extended view shows Pressure 1 and 2, Rate Shift, Pressure Relief, and wrench to access RightSpot Settings.

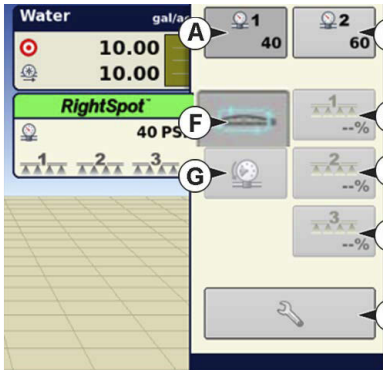

- A. Target Pressure 1
- B. Target Pressure 2
- C. Rate Shift Configuration 1
- D. Rate Shift Configuration 2
- E. Rate Shift Configuration 3
- F. Boom Recirculation enable/disable
- G. Pressure Relief
- H. RightSpot™ Settings

## RightSpot™ Settings

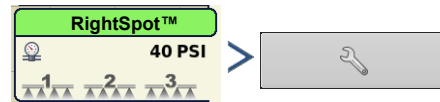

**Pressure Preset 1 and 2** — Press the +/- or press the center and enter the desired operating pressures.

## Rate Shift Configuration 1, 2, and 3

Rate Shift Configuration allows an operator to group the nozzles in up to three sections and scale the rate up or down. While running, the operator selects Rate Shift 1, 2, or 3 to engage, and selects Rate Shift 1, 2, or 3 to disengage.

To set up Rate Shift, navigate to the Rate Group Selection



1. Select Rate Shift 1, 2 or 3 at the bottom of the screen (A)
2. Select the nozzles that belong in the group (B)
3. Enter a Rate Scale (C)
4. Repeat steps 1-3 for each Rate Shift Group
5. Press  when finished

---

## Boom Recirculation

Boom recirculation offers many advantages over a standard plumbed boom. It saves time when priming the boom, simplifies sprayer cleanout, and greatly reduces boom contamination – a common source of crop damage.

**Boom Recirculation Checkbox** — To enable Boom Recirculation on RightSpot Toolbox check the box.



**NOTE!:** Sprayer must be equipped with boom recirculation plumbing.

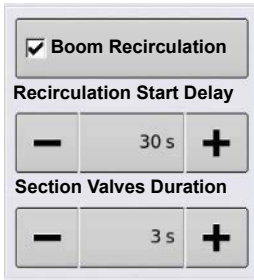

**Recirculation Start Delay** — Set the amount of time to delay recirculation after system has entered standby mode. When system enters standby mode, the Start Delay Criteria begins. Once that time has been reached boom recirculation will begin.

**Section Valves Duration** — Enter the amount of time each valve is open during the boom recirculation process.



**NOTE!:** To avoid application delays and erratic rates, the user should disable boom recirculation before starting to apply.

## Boom Pressure Relief



When Boom Pressure Relief is active the following message will appear on the screen. Once complete message will go away.



**WARNING!:** While Pressure Relief is active, product will be dispensing from the nozzles.



## Rate Control Settings



Press the Rate Setup button on the Product Control Toolbox to access the Rate Control Settings screen.

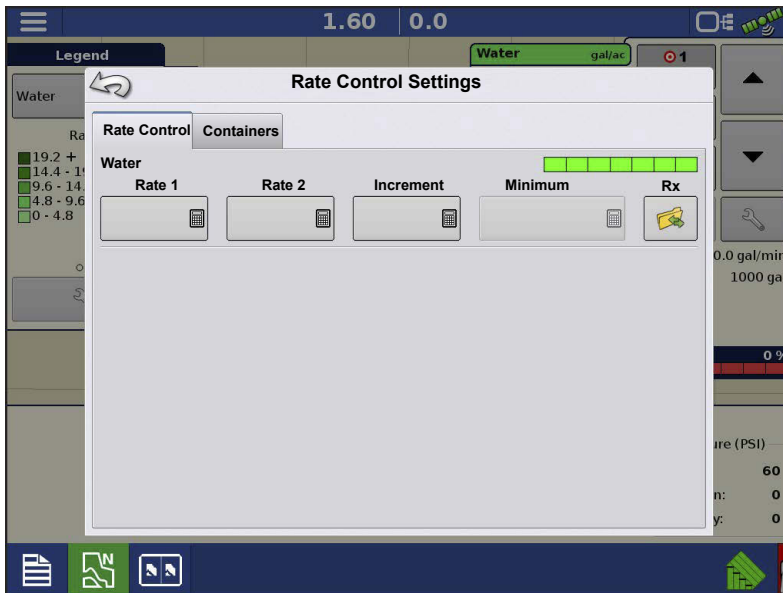

**Rate 1 and Rate 2** — The Rate 1 and Rate 2 settings represent preset application rates that allow operators to quickly change between desired target rates for each individual product.

Press  to enter the desired amount.

**Increment** — The Increment button allows operators to specify the increase or decrease amounts for a specified rate by using ▲ / ▼ on the Product Control Toolbox to enter the desired.

**Minimum Flow** — (Used for DirectCommand Liquid Applications only). This setting is used to maintain a consistent spray pattern. The display will not allow flow to drop below the entered setting. Set flow at the lowest operating pressure, with all sections on, for selected spray tips. When spraying with one or more boom sections off, the system automatically reduces the

Minimum Flow setting according to the reduced spray width. To adjust this setting, press  and enter the desired numeric value.

**Prescription (Rx)** — To load a map-based prescription file, press the Prescription button.

Refer to [Loading Prescriptions on page 945](#) for further details.

# Containers

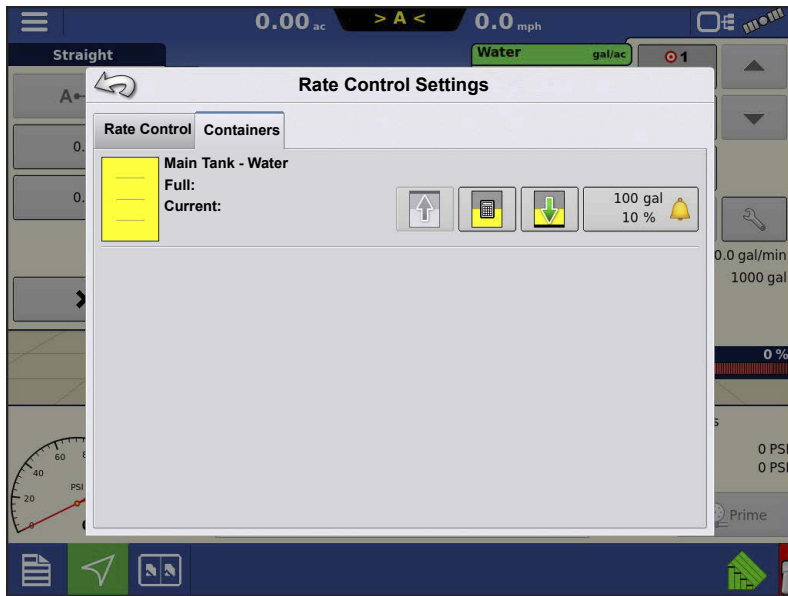

## Main Tank



Select to fill tank



Select to empty tank



Select to enter a specific amount

## Fill Flow Meters

DirectCommand L2 and RightSpot, when paired with Ag Leaders Vehicle Interface Module (VIM), offers automatic tank fill. This feature eliminates the need to manually adjust the container level.

## Raven Fill Stations

Raven Fill Stations are compatible with DirectCommand L2 and RightSpot when paired with the VIM. Machines must be equipped with Raven Fill Stations from factory.

## Liquid Control Options

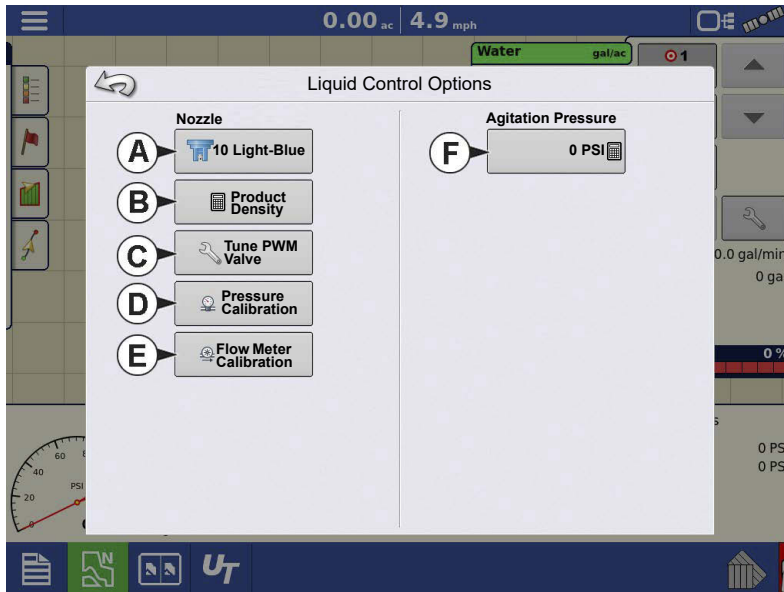
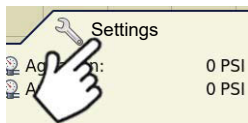

- A. Nozzle Selection
- B. Product Density
- C. Tune Valve
- D. Pressure Calibration
- E. Flow Meter Calibration
- F. Agitation Pressure

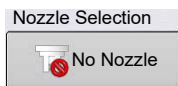

**Nozzle Selection** – Click the icon to open the selection options. Select an existing nozzle that matches the nozzle you are using or create a custom nozzle. A nozzle selection is required for RightSpot operation.

**Product Density** – Enter the product density.

**PWM Valve Tuning Utility** — Easily tune PWM valve settings from the run screen.

**Pressure Calibration:** Calibrate pressure sensor from the run screen.

**Flow Meter Calibration:** Calibrate flow meter from the run screen.

**Agitation Pressure** – Enter the pressure needed for agitation.



**NOTE!:** Agitation pressure control requires L2 to be connected to the sprayer agitation valve and an agitation pressure sensor.

## Nozzle Selection

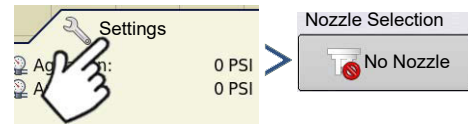
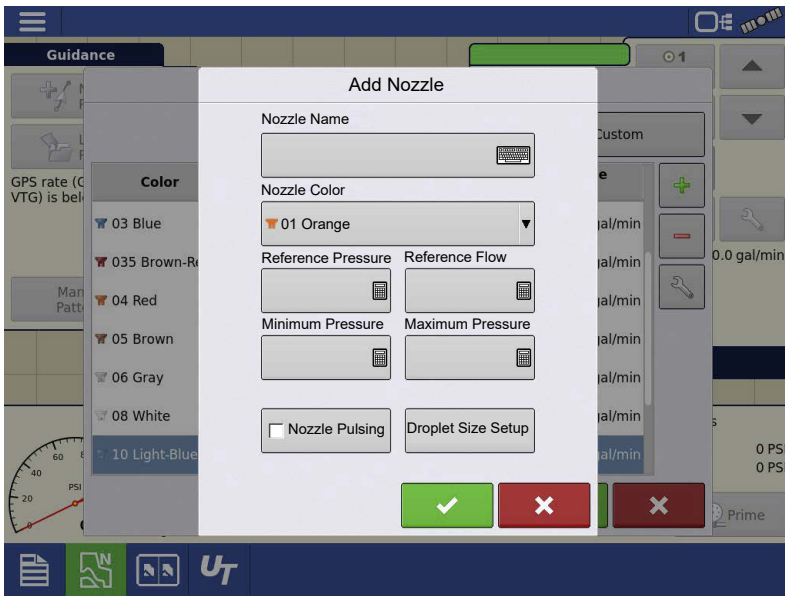

OR

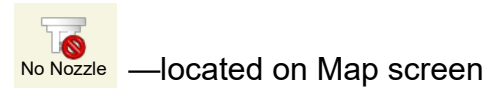

Nozzle selection is required. Generic nozzles are available to use for basic functionality.

### Functionality Requiring a Custom Nozzle

The user must create a custom nozzle, and input the appropriate settings, to perform advanced functionality such as:

- Disabling nozzle pulsing
- Droplet size monitoring
- Minimum flow capabilities
- Custom values for flow capacity,
- Alerts when operating outside the effective pressure range of the nozzle

### Creating a Custom Nozzle

1. Select 

2. Enter:

- Nozzle Name
- Nozzle Color
- Reference Pressure
- Reference Flow
- Minimum Pressure

- Maximum Pressure



**NOTE!** If an AI nozzle is desired, work with your nozzle manufacturer to ensure it is approved to work with PWM systems or uncheck Nozzle Pulsing and operate like a standard sprayer with individual nozzle section control.



Nozzle Pulsing

When unchecked your sprayer will function like a standard sprayer with nozzle-by-nozzle autoswath. Nozzle Valve Assemblies remain open during operation.

Droplet Size Setup

Enables the droplet size reference to the pressure gauge on the map screen.

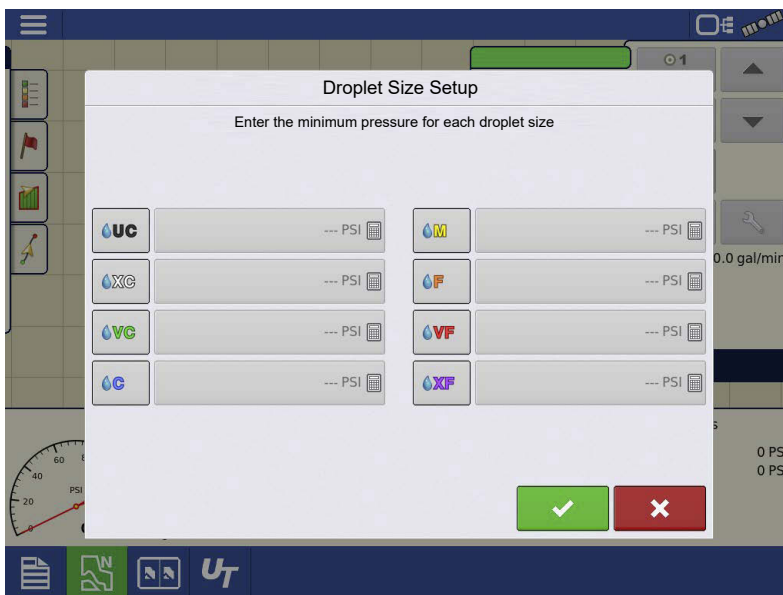

Enter the minimum pressure for each droplet size.

# Product Density

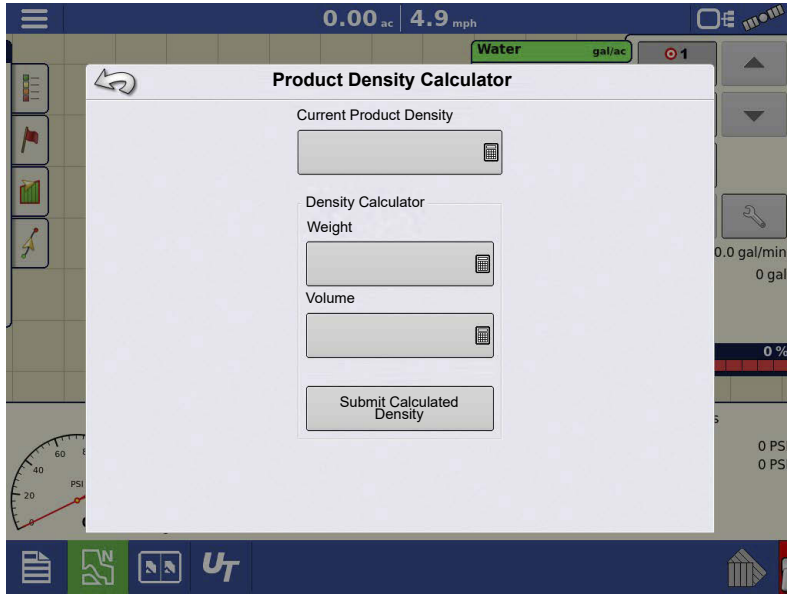
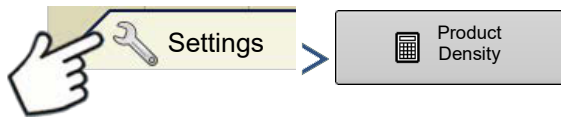

Enter product density for a generic product or mix created. Products made that are already in the display will already contain the density.

If density is not known for a generic product, use the calculator for an accurate density.

## PWM Valve Tuning Utility

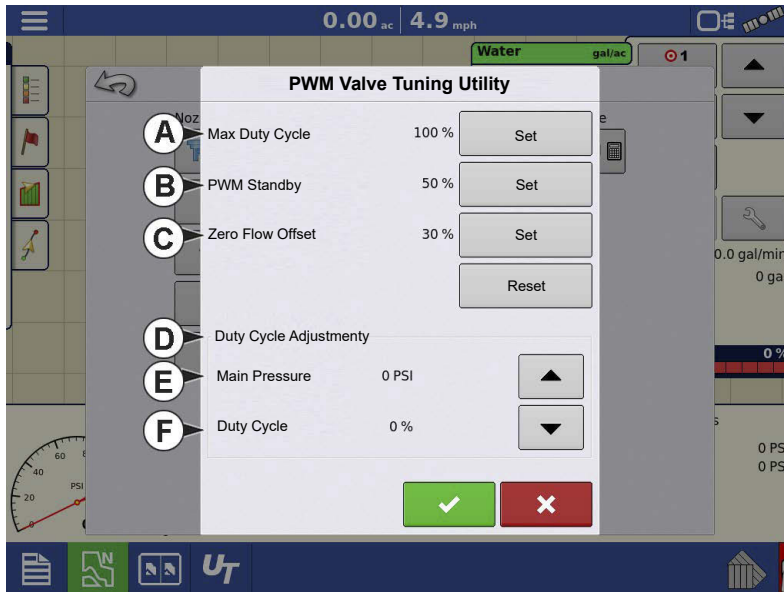

Easily adjust the PWM Flow Control Valve settings from the run screen.

**A. Maximum Duty Cycle** — Sets an upper limit for duty cycle. The valve will not operate at a higher duty cycle than the percent entered.

- B. PWM Standby** — User defined setting that determines the percent duty cycle the system uses when boom sections are all off. This setting must be greater than the Zero Flow Offset.
- C. Zero Flow Offset** — Maximum duty cycle that is sent to the control valve without producing flow from the product pump. Default value is 30. Use the Duty Cycle Adjustment tool achieve the correct setting.
- D. Duty Cycle Adjustment** — ▲ / ▼ allow the user to command a duty cycle to the product control valve without dispensing product. This allows the user to increase or decrease the pump output and observe the resulting response to help set the desired duty cycle for the above settings.
- E. Main Pressure** — The current reading from the systems calibrated pressure sensor
- F. Duty Cycle** — Percentage the L2 rate controller is sending to the valve.



**NOTE!:** To fully adjust the flow control valve access the control valve settings. See

[Control Valve Settings - PWM on page 961.](#)

## Valve Control Setup

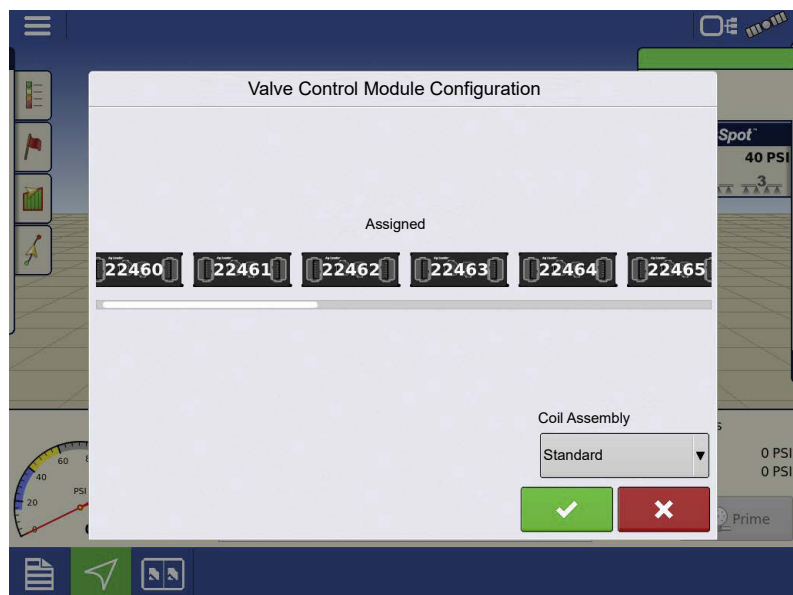

Valve control setup offers an easy way to reorder the valve control modules to allow them to index properly. Valve control setup is also where the operator selects the series of nozzle valve assembly that is installed.

**i NOTE!:** It is highly recommended to install the valve control modules in numerical order by the last three digits of the serial number, left to right, on the sprayer boom. The VCM setup is only recommended when replacement VCMs are installed.

**i NOTE!:** Turn off Ag Leader display when making physical changes to the VCMs and their cabling. This ensures proper indexing and configuration setup.

Within the valve control module configuration, hold down the valve that needs moved. It will highlight in blue. Select left or right arrow to move it to the correct location.

Select the coil assembly installed on your machine from the drop-down menu —choose Standard (15 series) or High-Rate Fertilizer (24 series).



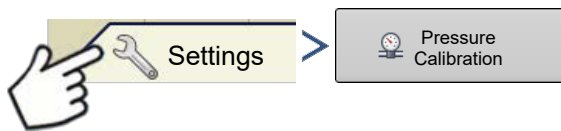

## Pressure Calibration



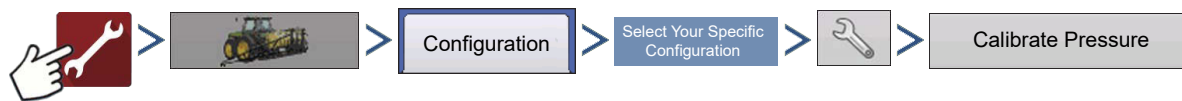



OR







1. Choose Main, Agitation or Aux from Drop-down box. Press .

2. Select Set Point Type and Sensor type. Press .

**Single Set Point:** Enter Voltage / Pressure Ratio  Record Calibration Point (PSI must be zero before recording) .

**Single Set Point with Current Loop:** Enter Voltage / Pressure Ratio  With PSI of Zero, Record Calibration Point. Press .

**Multiple Set Point with Voltage:** Set pressure to 0 Psi and select Record Calibration Point  Enter the known boom pressure and Record Calibration Point. Press .

**Multiple Set Point with Current Loop:** Set pressure to 0 Psi and select Record Calibration Point  Enter the known boom pressure and Record Calibration Point. Press .

---

## Flow Meter Calibration

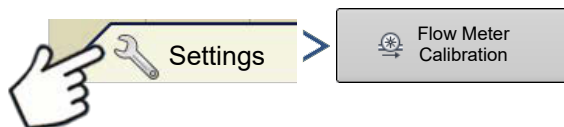

### 1. Select Calibration Type:

- Manual
- Field Dispense Volume
- Nozzle Catch Test.

Press .

#### **Manual**

Enter the pls/gal for the product control flow meter 1.

- This value can typically be found on the flow meter tag.
- Raven flow meter pls/gal must be divided by 10 prior to entering value in display.
- Flow meter 2 is used ONLY if there are two product control flow meters on your system. If there is not, leave it to zero.

#### **Field Dispensed Volume**

Start applying product for a desired amount of time. Once complete, verify the volume applied. Enter the Actual Volume Dispensed in the flow meter calibration window.

- The volume measured is based on current region. It is suggested to create a new region prior to beginning Field Dispense Volume Calibration.

#### **Nozzle Catch Test**

Make sure you have a pitcher to gather solution and a watch to verify time. Enter target rate and a manual speed. Select Start. Select Stop once the desired amount of time has passed. Enter the volume of the solution collected and the time measured. Flow meter calibration will adjust.

Complete calibration by selecting the .

## Loading Prescriptions

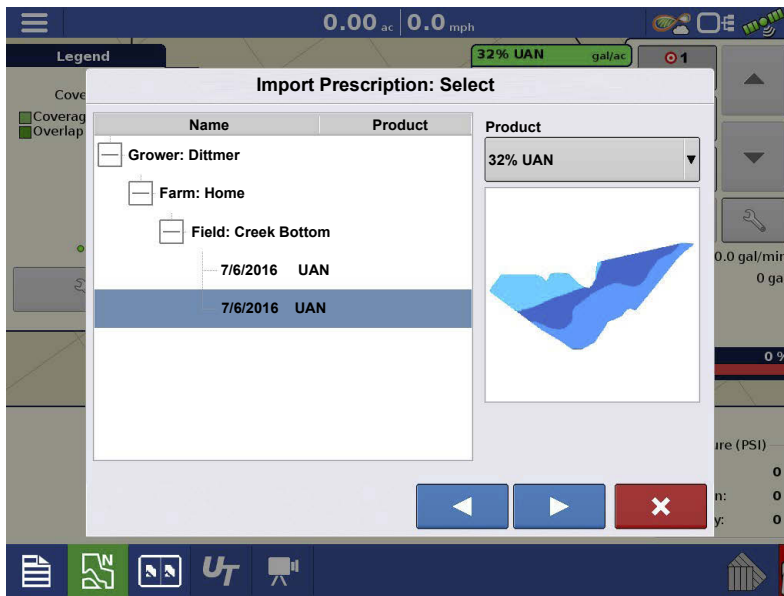

1. Press the Rate Setup button on the Product Control Toolbox.

2. Press the Load Prescription button.

3. Using an inserted USB or AgFiniti Cloud, search for and highlight the correct .agsetup, .irx, or shape file and press .

4. Select the prescription in the Select Prescription screen, and select the correct controlling product from the Product drop-down box. A preview prescription map is displayed. Press .

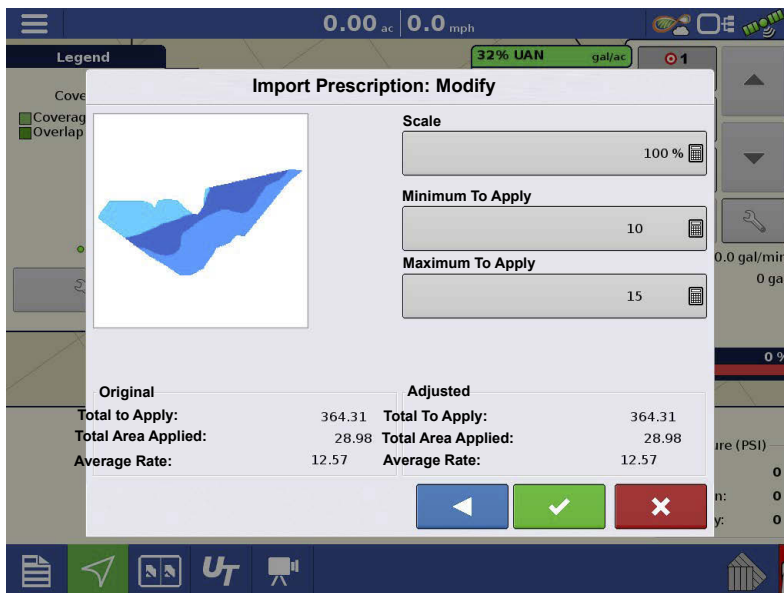

5. In the Modify Prescription Screen the prescription scale, minimum to apply, and maximum to apply can be changed. As the three parameters are changed, the adjusted total to apply and average rate will update accordingly.

6. Press the .

7. After returning to the Mapping Screen, the prescription will appear on the map while in a North Oriented view.

## Shape File Conversion

What is commonly called a shape file is actually a collection of different files. All three of the files are required and must be present on the USB drive for the system to use shape files for variable

rate product application. A single shape file can contain recommendation rates for multiple products.



1. To begin, press the Rate Setup button on the Product Control Toolbox.

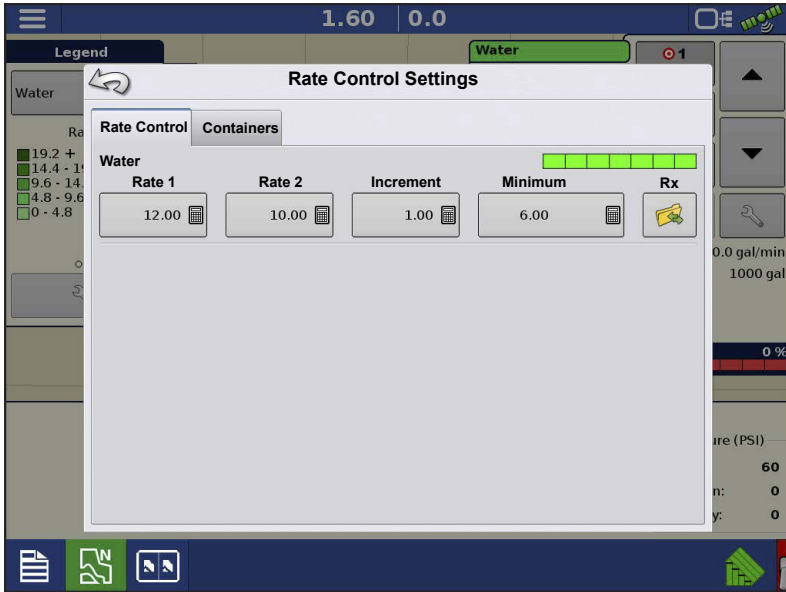

The Rate Control Settings screen appears.

2. Press the Load Prescription button.

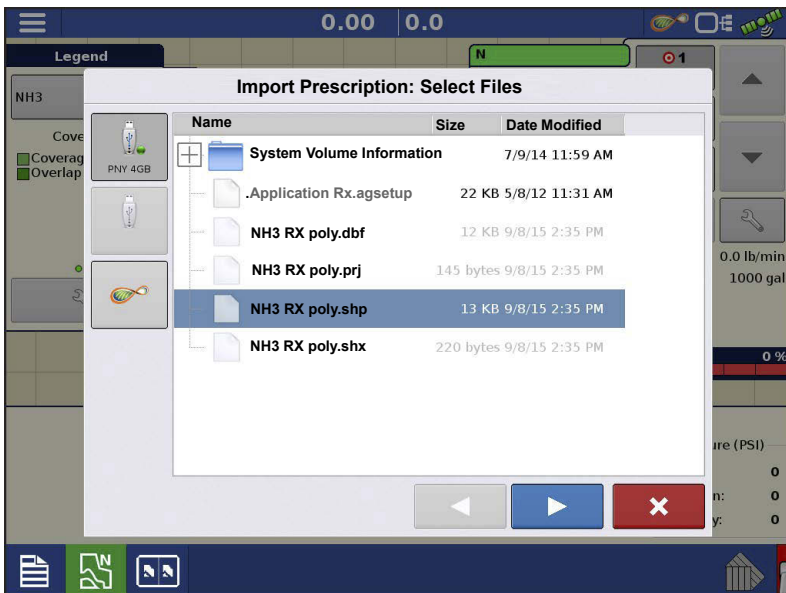

3. The Select File screen appears.

Highlight desired .shp file and press



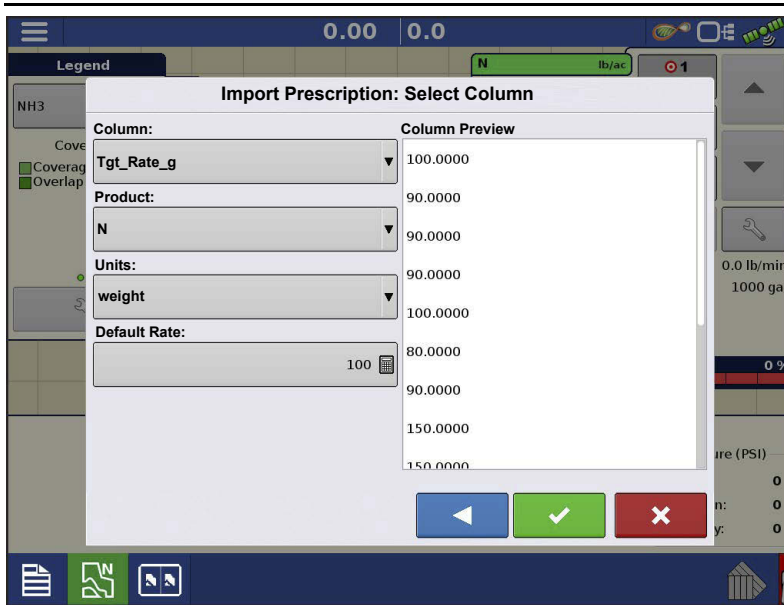

#### 4. Select Column From Shape File—

Select the column that contains the product recommendation target rate. The list on the right side of the dialog shows sample data from the selected column.

5. **Select Units**—Select the controlling units for product application.

6. **Default Rate Setting**—The system assigns a default rate. Use the on-screen keypad to edit the value if desired.



**NOTE!:** Select the product and units that the shape file prescription was made for. Selection of the wrong data column or unit will result in misapplication of product.



**ATTENTION!:** The only time the default rate is used by the system during product application is if the Rate Outside of Field selection is set to "Rx default". This setting is located in the Equipment Settings portion of configuration setup. If the Rate Outside of Field selection is set to "Rx default", the default target rate will be used when the vehicle exits the area covered in the prescription map.

## Creating Products

Creating application products and product templates can be completed during initial setup, or from the Product Selection screen of the Field Operation Wizard when starting a field operation.

### Creating Single Products

To create a single product, to be added to a product template or to be applied by itself, use the on-screen wizard described in the following steps.



---

Select:

1. Product Type
2. Product Units
3. EPA Product Number (Optional)

Check box if product is a Restricted Use Pesticide.

4. Manufacturer name if applicable.

Manufacturer name can be added to the drop-down menu by pressing .

5. Press  to enter a unique name for the product.

Created product will appear under the Application heading located on the Product tab of the Configuration Setup screen.

 **NOTE!:** Some Fertilizer and Carrier product types are predetermined in the display. These product names cannot be edited. Their Manufacturer and EPA Numbers can be edited after the product is created.

Examples are: Fertilizer  DAP or Carrier  30% UAN.

## Creating Product Template

Product Templates are set up by using the on-screen wizard.

 **NOTE!:** Prior to making a new product template, it is recommended to add the individual products to the list in the units recommended by the chemical label.

It is recommended to create product templates that contain the products applied for a crop type or time of the season.

Examples are:

- Pre-Emerge Burndown
- Post-Emerge Corn
- Post-Emerge Beans
- Insecticide
- Fungicide

In each template the products can be checked on/off for the mix when loaded at the run screen.



### 1. Select Tank Mix.

#### Define By

- Total amounts - mix/blend defined by amounts added to the tank (total of each product in tank)
- Rate/acre - mix/blend defined by the amounts applied per acre (rate of each product applied/area)

### 2. Enter a Base Amount or Base Rate and Units.

- Total Amounts - Tank/Bin Size
- Rate/Acre - For Rate Applied per Acre



### 3. Select Carrier.

- Press  to create a new carrier.

### 4. Press by the Add Mix/Blend Contents box to start the process of adding components to the mix.

### 5. Select the desired component from the drop-down menu.

 **NOTE!:** More than 7 products can be part of a template, but only 7 or fewer can be active at the same time.

- A new product can be set up at this time by pressing  and following the Product Setup Wizard.
- Press  to add selected product, or press  to return to Add Mix/Blend screen without adding a product.

### 6. Press to add an additional product.

### 7. When all components have been added press .

---

8. Enter Manufacturer name if applicable.

•Manufacturer name can be added to the drop-down menu by pressing .

9. Press  to enter a unique name for the mix/blend.

• Press  to complete the process of setting up the mix/blend, or press  to return to the Configuration Setup screen without adding a mix.

The product mix/blend appears under the Application heading located on the Product tab of the Configuration Setup screen.



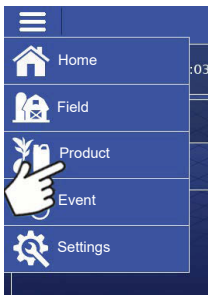

Represents Product Templates

## Configure Product Mix

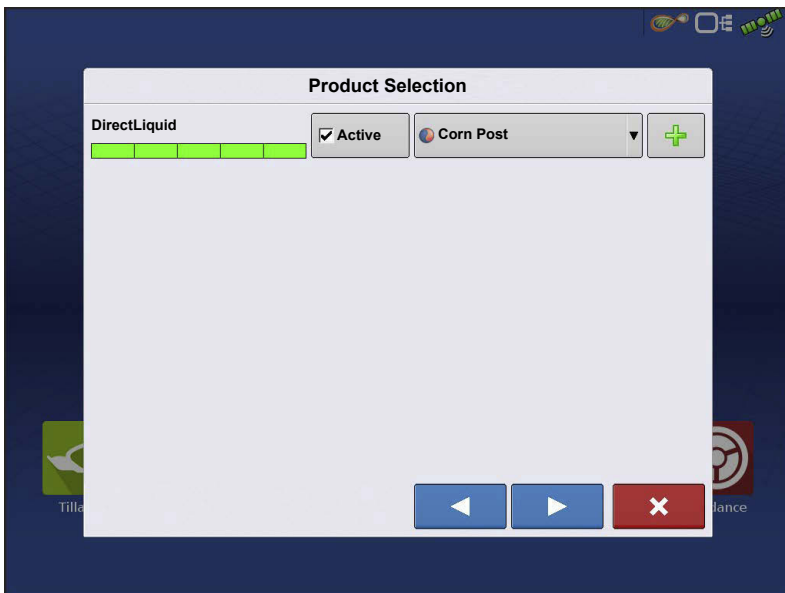

When using a product template, the mix contents and amounts are defined in the Configure Product Mix screen available in the Event Setup Wizard, or Product button in the main menu.



1. Select mix/blend from the drop-down list or press  to create a new mix/blend.





2. The product template mix contents and amounts are defined by:

- A. activating or deactivating products
- B. changing rate or total amount of product

C. changing total amount of the product or overall rate of product application

A product cannot be active with a rate of zero. Press  to access the Mix Calculator.

3. When a product template is setup using rate/area, the Mix Calculator can be used to show how much of each product to put in the tank when the user enters the desired amount to fill.

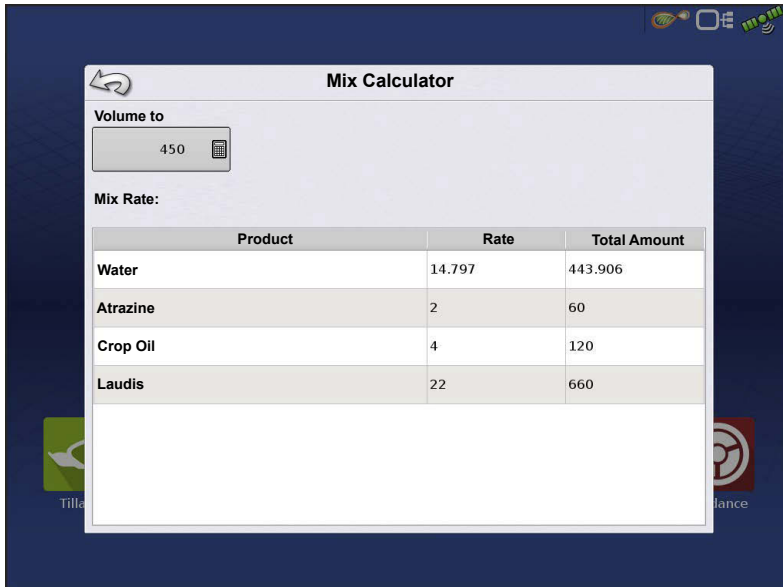

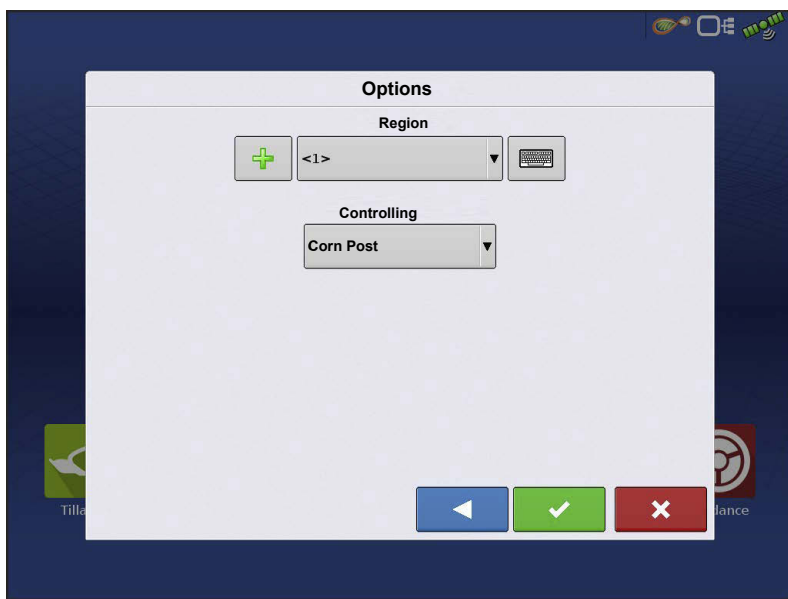

4. Press the Volume to Calculate button and input the total volume.

Table will give the user the amount of each product to put in the tank.



5. Select Region from the drop-down menu or press  to name Region.

Verify the Controlling Product for the Mix/Blend.

Press  to load the Event to the Map Screen, or press  to return to Home screen without setting up an Event.

## Create Configuration

A wizard will step through the process of selecting or creating a configuration with application settings.

Press:



OR

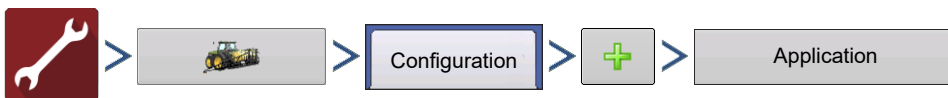

Operating Configuration will be viewable when starting a new Field Operation with the Application Wizard.

**Manage Equipment** button can also be used to create or edit specific vehicles and implements.

## Active Nozzles

When creating a RightSpot Configuration an operator must set Active Nozzles. In most cases the number nozzles on the boom and Active Nozzles will be the same. At times, operators may have an additional configuration with less Active Nozzles than total nozzles for fertilizer application, Y-drop application, or other applications.

**Equipment Setup Wizard: Nozzle Count**

RightSpot™

Total Number of Nozzles  
- 1 +

Nozzle Spacing  
- 30 in +

Full Swath: 2.5000 ft

Navigation buttons: Back, Forward, Cancel

1. Begin by creating a new RightSpot Configuration.

2. Continue through the configuration process until you reach this screen.

**Equipment Setup Wizard: Nozzle Count**

RightSpot™

Total Number of Nozzles  
- 72 +

Number of Active Nozzles  
- 36 +

Nozzle Spacing  
- 30 in +

Full Swath: 180.0000 ft

Navigation buttons: Back, Forward, Cancel

3. Check mark RightSpot.

**Equipment Setup Wizard: Nozzle Count**

RightSpot™

Total Number of Nozzles  
- 72 +

Number of Active Nozzles  
- 36 +

Nozzle Spacing  
- 30 in +

Full Swath: 180.0000 ft

Navigation buttons: Back, Forward, Cancel

4. Enter the Total number of nozzles on the system and their spacing.

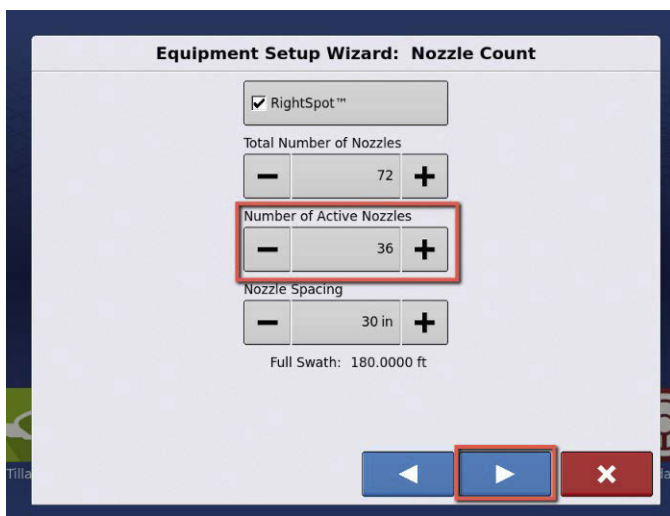

5. Enter the number of active nozzles for this setup.

6. Press .



7. Select all the nozzles that will be active. The number of selected nozzles must match the number of active you entered above.

8. Press  to continue the configuration.

## Implement Offsets

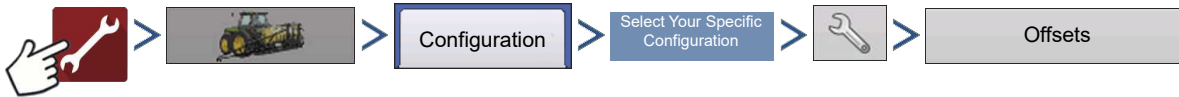

OR

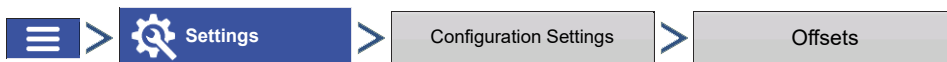

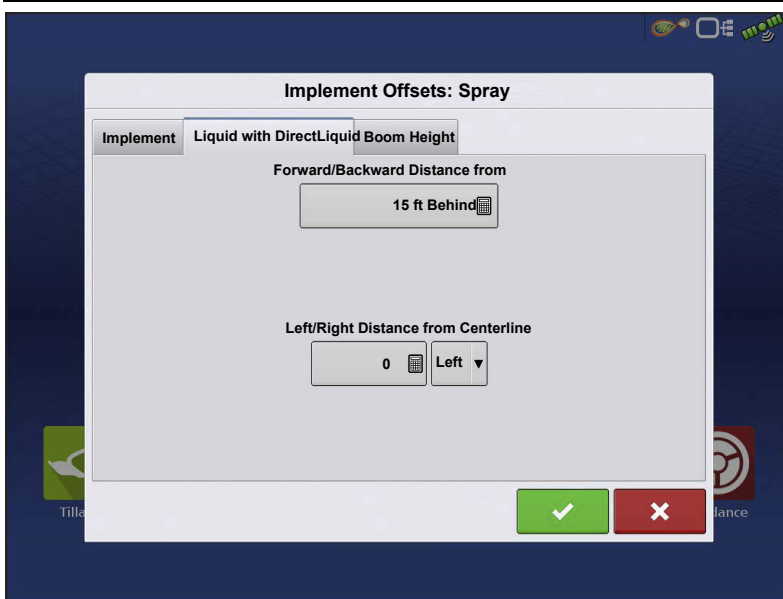

Implement Offsets screen appears, with each channel's settings shown on its own tab.

Defaults to the value entered during Configuration Wizard.

Boom sections can independently be offset forward or back (Application Operation Only).

1. Press  to access Swath Section Offsets screen.

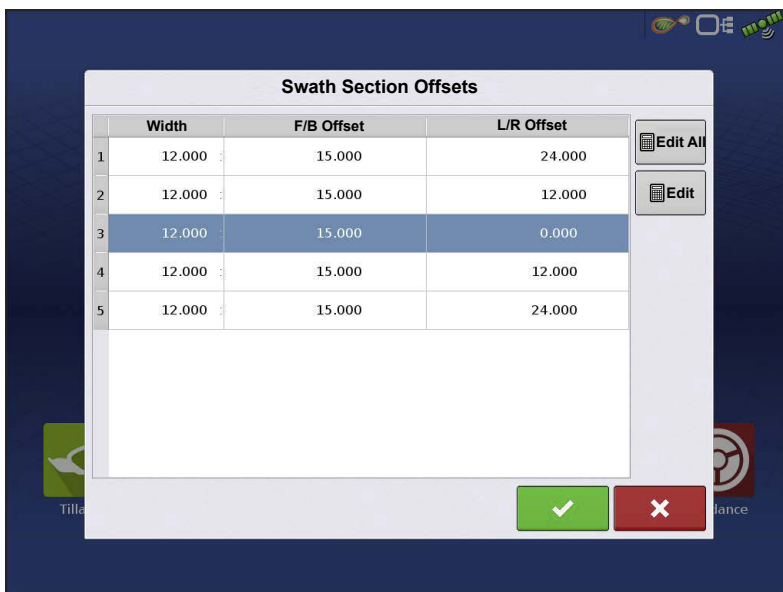

2. Select Swath section to edit and press Edit button.

3. Enter offset for that specific section and Forward/Backward from rear axle.

Press  to enter change. Setup will indicate which offset is entered

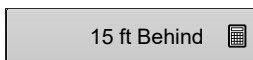

**Global**—All sections have the same offset.



**Individual**—At least one section has a different offset.

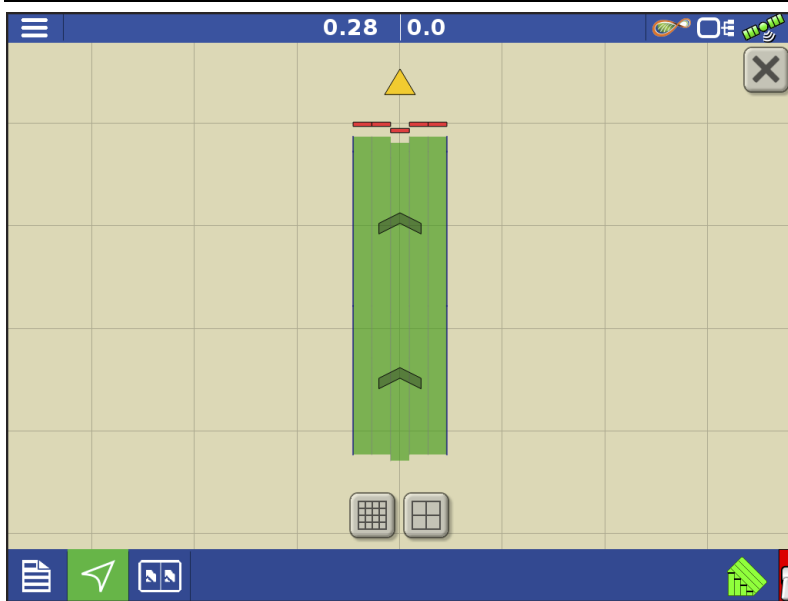

Runscreens reflect section offsets

## Equipment Settings

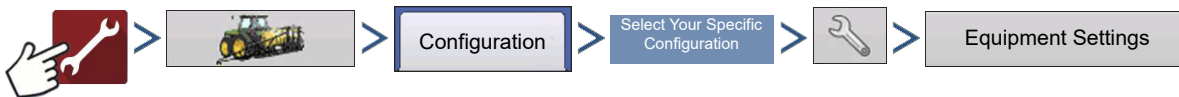

OR

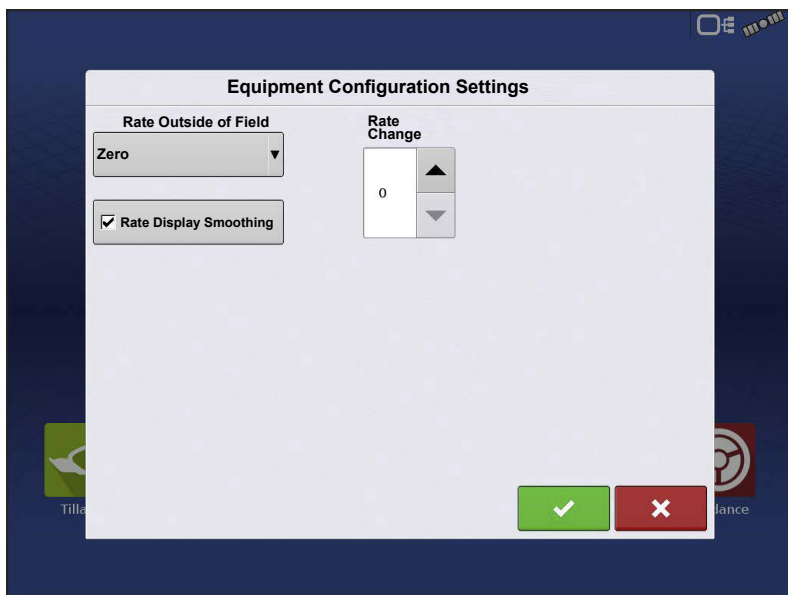

**Rate Outside of Field**—This setting will define how product will be controlled when leaving a field boundary.

- **Zero**—This will stop application.
- **Last Good**—This will continue application at the last known rate.

• **Rx Default**—When using a prescription, this will apply at the Default Rate (or outside of boundary rate) as defined by the prescription file.

**Rate Display Smoothing**—Determines how the feedback from the control channel rate sensor will be displayed on the map screen. When not selected, the system will display raw feedback from the rate sensor. When checked, the system will display target rate when the application rate is within 10% of the target rate setting.

**Rate Change Look-Ahead**—This setting compensates for any latency in the control system when changing between different product flow rates during variable rate application. The typical setting range for this is 0-1 seconds. This setting can be thought of as a “look ahead” value when using a variable rate prescription. The display will send the signal to change rates before hitting a transition line so that the applied rate is correct when crossing into the new management zone.

## Auxiliary Input

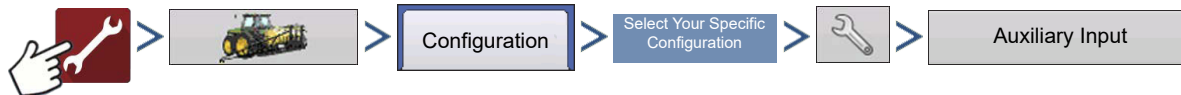

OR

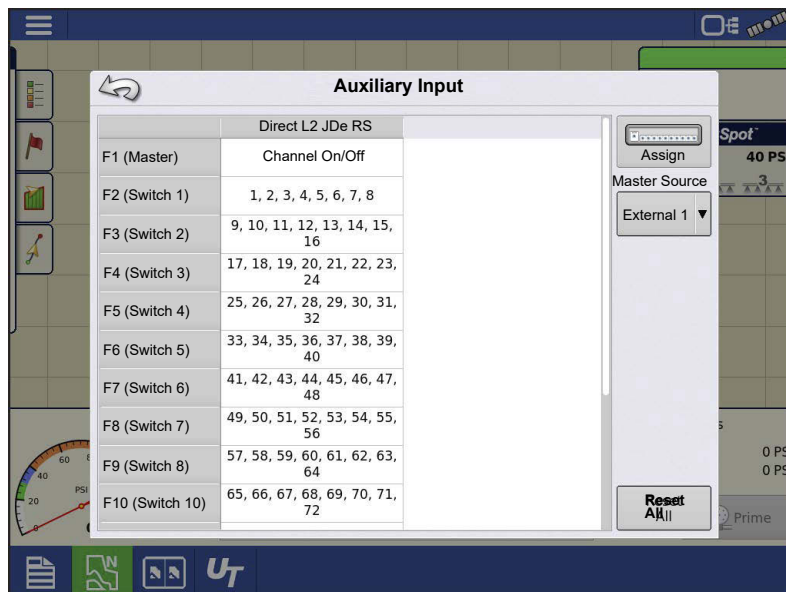

DirectCommand applications default boom sections to the switchbox in order, starting with switch 1. From the Auxiliary Input screen, the operator can customize the switches to the boom sections, if desired; or assign left/right fence row nozzles.

1. Press  .
2. Highlight the desired switch to assign a function to it.



3. Select appropriate function(s) (boom sections for this operation) to assign to the desired switch. Chain icons within each function will "link" once pressed to indicate they are assigned. If a function has a "broken link" then it is not assigned. If a switch has an "X" then it is not assigned to a function. Press  to save the setup.

 **NOTE!:** Even if no specific functions are assigned to the Master Switch, the Master Switch will still serve as the total system on/off switch.



## Fence Row Nozzle Indicators

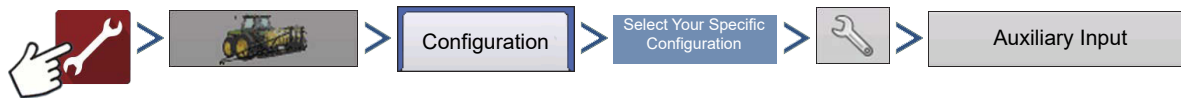

Control fence row nozzles through the DirectCommand system by mapping the switches in Auxiliary Input Settings. Fence row nozzles can be mapped to any switch.

After specifying Fence Row Nozzle settings at the Auxiliary Input Assignment screen, the **Fence Row Nozzle Indicators (A)**, which are shaped like triangles, appear on either side of the sections behind the vehicle icon.

**i NOTE!:** If a switch is selected as a left or right fence row nozzle, the system sends power from the last swath module out of pin11 for the left fence row nozzle, or pin 12 for the right fence row nozzle, for a 12V signal valve. When using polarity reversing valves, the left fence row nozzle is controlled by pins 9 and 10 and the right fence row nozzle is controlled by pins 11 and 12. When using polarity reversing valves, the left fence row nozzle is controlled by pins 9 and 10 and the right fence row nozzle is controlled by pins 11 and 12.

**i NOTE!:** The boom sections next to the fence row nozzles must be turned on before the fence row nozzle can be turned on.

**i NOTE!:** If multiple swath modules are needed for operation, left and right fence row nozzles are assigned to the last swath module with the same pin assignment stated above.

# Implement Modeling

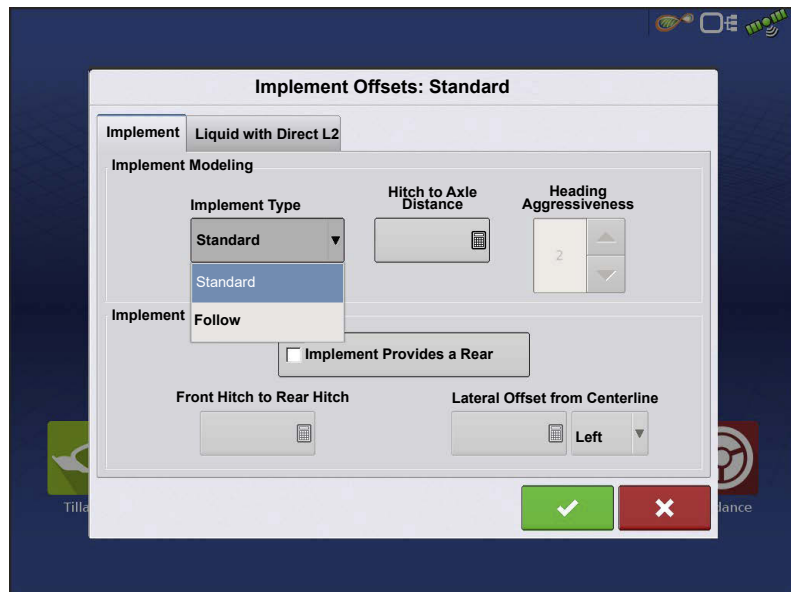
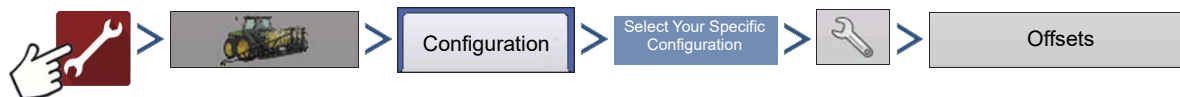

When using implement modeling, the implement type can be set to Standard or Follow. This selection adjusts how the display models the path of the trailed implement.

If a trailed implement utilizes a steerable axle, the Follow feature can be used.

## • Heading Aggressiveness

The Heading Aggressiveness setting can be used to fine tune mapping of a trailed implement that has a steerable axle or wheels. The setting ranges from 0 - 10. The default value is 2.

An aggressiveness setting near 0 or 1 will model an implement that follows the path of the vehicle.

As the aggressiveness setting is increased, the modeling resembles an implement that steers outside the path of the vehicle. The modeling becomes more exaggerated the closer the setting is to 9 or 10.

## Liquid Application Controller Settings

### Controller Settings

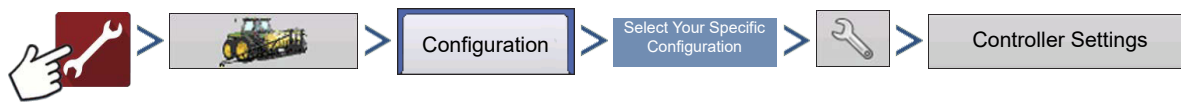

OR

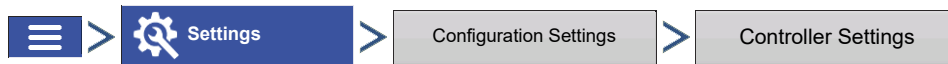

### Control Feedback

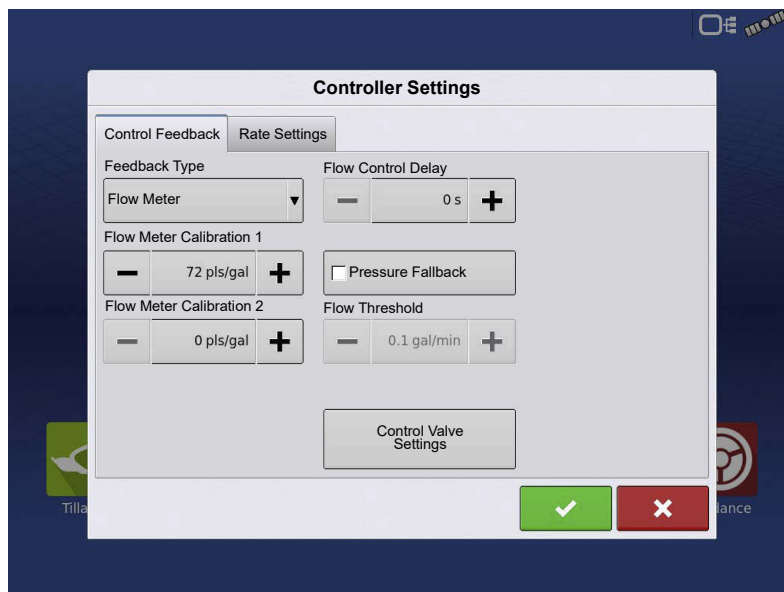

**Feedback Type** – Select the sensor type being used. Flow meter or Pressure Sensor.

**NOTE!** When operating RightSpot the Feedback Type must be Flowmeter.



**WARNING!** If Feedback Type is set to Pressure while operating RightSpot there is high risk for improper application.

**Flow Meter Calibration 1** — Calibration value representing the number of pulses that equal one gallon of product flow through the controlling system. This value can typically be found on the flow meter tag. For Raven flow meters, divide this value by 10 before entering it in the display.

**Flow Meter Calibration 2** — This only needs entered if your system has two flow meters. Calibration value representing the number of pulses that equal one-gallon of product flow

---

through the controlling system. This value can typically be found on the flow meter tag. (For Raven flow meters, divide this value by 10 before entering it in the display.)

**Flow Control Delay** — Specifies the time delay from a commanded rate on to when the system actively begins flow control based on flow sensor feedback. This setting can be used to eliminate unwanted correction of flow control at the start of each pass. For RightSpot, typical values for flow control delay are 0-1 second.

**Pressure Fallback** – Pressure Fallback is a setting that allows the system to automatically switch between flow based and pressure based control. Pressure Fallback is beneficial in low flow situations where a flow meter may be less accurate or not provide the necessary resolutions to provide reliable flow control. In flow rates below the user defined Flow Threshold, the system will transition to Pressure Fallback and utilize pressure sensor feedback for flow control. Both a flow meter and a pressure sensor must be present on the machine to use Pressure Fallback.

**Flow Threshold** — Set the range of flow that will tell the system to switch between flow based or pressure based control. For example, setting the threshold to 10 gallons/minute will result in the system using the flow meter when flow is greater than 10 gallons/minute and using the pressure sensor when flow is less than 10 gallons/minute.

**Control Valve Settings** — Opens the Control Valve Settings screen, which displays control valve settings for PWM, Servo, Calibrated Reflow and Ramsey Valve Controls.

## Rate Settings

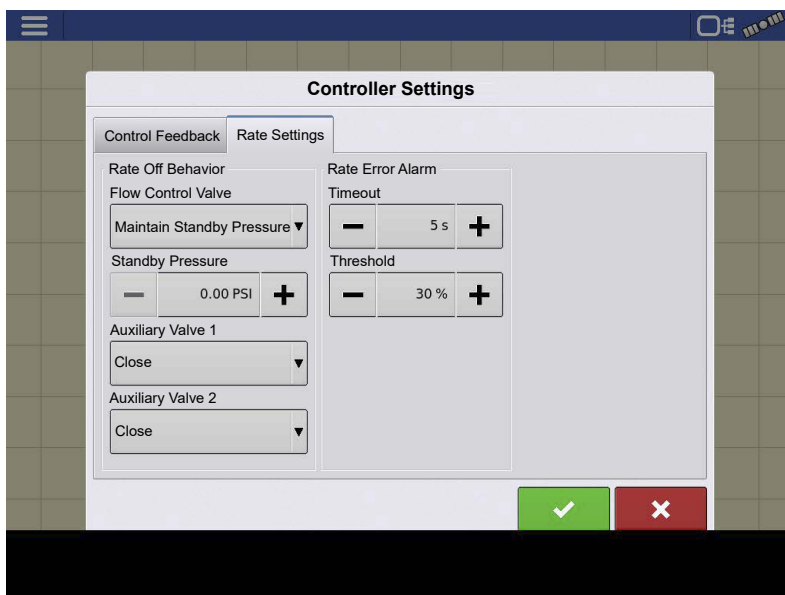

### Flow Control Valve

A.Hold: The product control valve remains in the last known state when all sections are shut off.

B.Close: The flow control valve shuts down when there is either a zero rate in the field or when entering an already-applied area.

C. Maintain Standby Duty Cycle: The controlling system remains in the Standby Duty Cycle set in the control valve settings for PWM Standby.

D. Maintain Standby Pressure: The flow control valve achieves the Standby Pressure defined by the user.

**Auxiliary Valve 1 & 2** —When all boom sections are off, this setting closes or opens an auxiliary valve. Choose settings for up to two auxiliary valves.

**Threshold** —The user-defined percentage of actual rate error allowed before an alarm sounds.

**Timeout** —The number of seconds that an actual rate falls out of the error threshold before an alarm sounds.

## Control Valve Settings - PWM

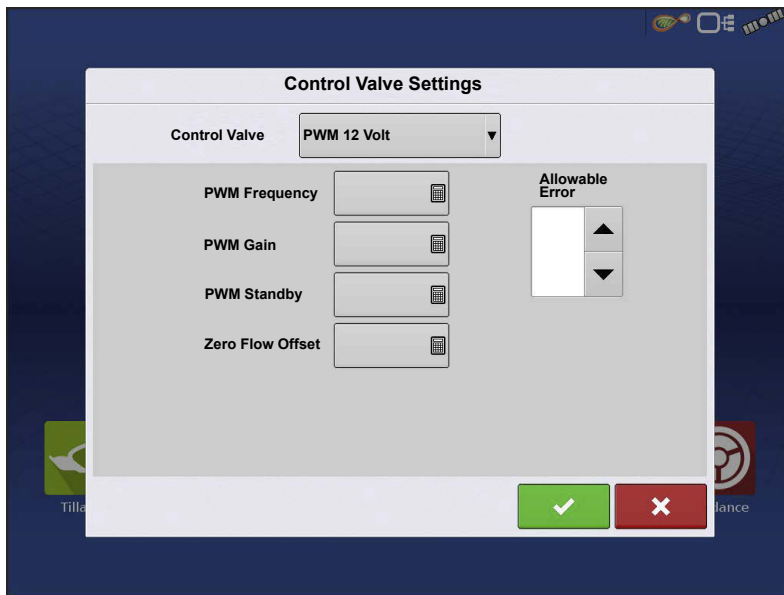

**PWM Frequency** — Settings determined by the manufacturer of the valve. Default Value is 100. Typical settings range from 100-125 Hz.

**NOTE!**: See PWM valve manufacturer information for recommended settings.

**PWM Gain** — Determines how aggressive the control valve responds when making rate or pressure change adjustments. The higher the value the more aggressive the system response is. Default Value is 800.

**Zero Flow Offset** — Represents the maximum duty cycle that is sent to the control valve without producing any hydraulic flow from the PWM valve. Using too high of a Zero Flow Offset value can cause the product control system to not properly control low rates or shut off. Default Value is 30. See the PWM valve manufacturer information for recommended settings or use the PWM tuning tool to determine the correct zero flow offset.

---

**PWM Standby** — This is a user-defined setting that determines the percent duty cycle the system uses when the boom sections are all off. The setting must be greater than the Zero Flow Offset.

**Allowable Error** — This maximum allowable error before the control valve commands a change in flow.



**NOTE!** The current PWM Duty Cycle can be viewed at the Liquid Diagnostics screen.

## Control Valve Settings - Servo

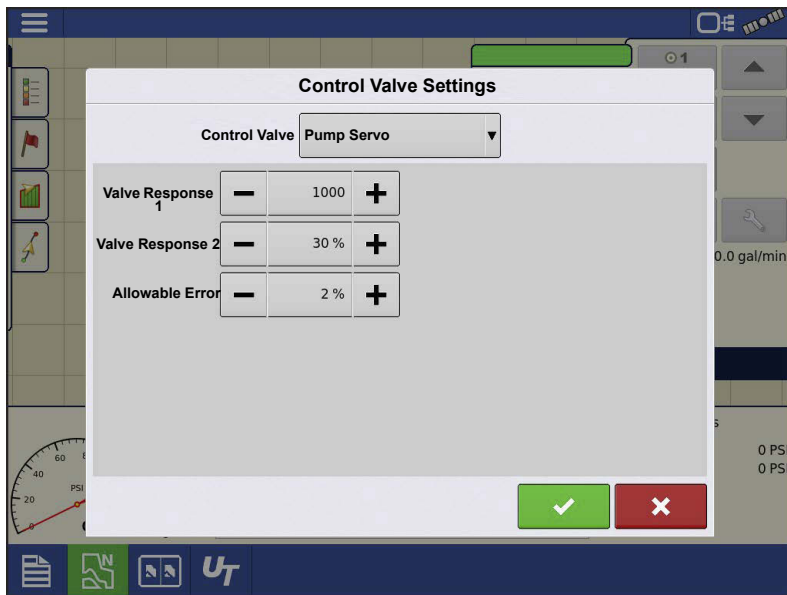

**NOTE!** Inline Servo is NOT supported with RightSpot. Converting plumbing to ByPass is required.

**Valve Response 1** — Determines how aggressively the servo valve will respond when there are large deviations from the target pressure. Decreasing the valve will cause the servo valve to respond slower.

**Valve Response 2** — Determines how aggressively the servo valve will respond when there are small deviations from the target pressure. Decreasing the valve will cause the servo valve to respond slower.

**Allowable Error** — Determines the acceptable error in pressure before the system commands the valve to adjust.

## Container Level Settings

When filling or emptying container, use the Container Level portion of the Rate Control Settings screen to update the amount of product in the containers.

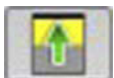

**Tank Fill** — The Tank Fill button increases the container level logged in the display to the user-defined maximum volume (specified in the Container Setup Wizard).

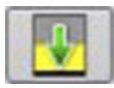

**Tank Empty** — The Tank Empty button decreases the container level logged in the display to zero.

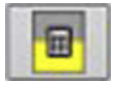

**Tank Partial Fill** — The Tank Partial Fill button changes the container level logged in the display to specific amount specify by pressing calculator icon. Pressing the Partial Fill button summons the Adjust Container Amount screen.

## Adjust Container Amount

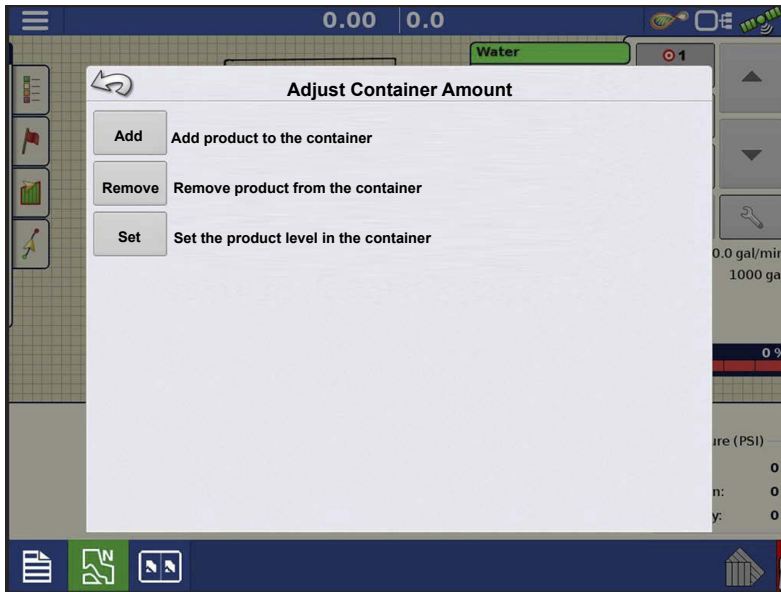

•**Add** — Adds product to the container.

•**Remove** — Removes product from the container.

•**Set** — Sets the product level in the container.

## Fill Flow Meter

- Machines equipped with a Fill Flow Meter will see the container level increase on its own when refilling the tank.



NOTE!: This requires a VIM and the machine must have an OEM fill flow meter

## Tank Alarms

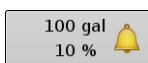

The Container Alarm button, which appears on the right of the Container Level portion of the Rate screen, displays the capacity of the tank as well as the percentage at which the Low Container Level warning will sound. To adjust these settings, press the button and the Container Alarm screen appears.

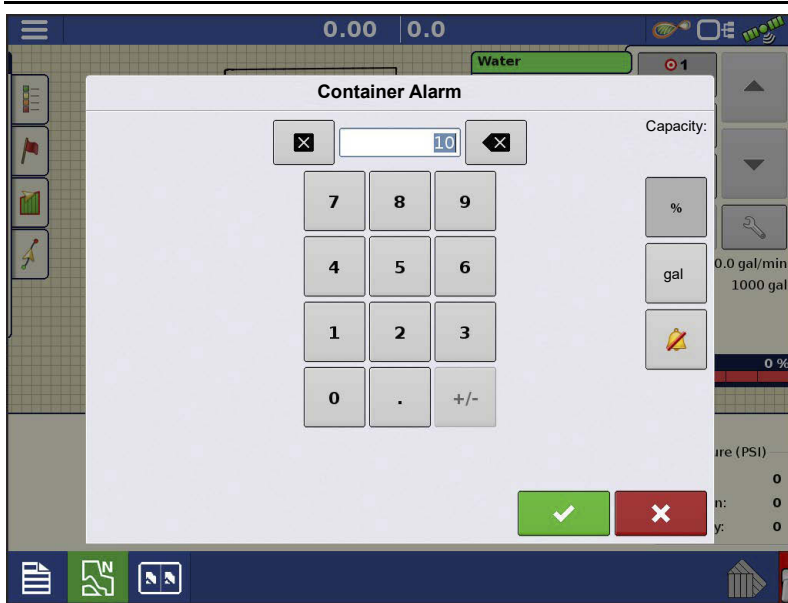

Adjust container level warnings using the following buttons on the right-hand side of the Container Alarm screen.

The **percentage (%)** button sets the warning threshold according to the percentage of solution left in the tank. In the example, to the left, the threshold is set at 10 percent.

The **units of measurement** icon sets the warning threshold according to the amount of solution left in the tank. This icon is named according to the container’s units of measurement specified during the Controller configuration procedure.

The **Disable Low Container Level** button, which appears as a bell with a red slash across it, disables the Low Container Level warning.

## Liquid Application Diagnostics

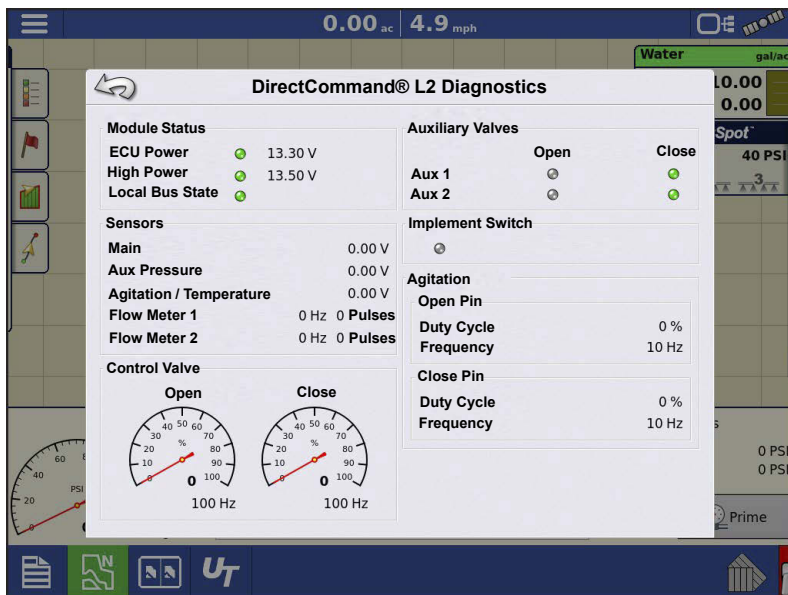

To go to the Liquid Diagnostics screen, press



At the Devices screen, highlight the item marked **DirectCommand L2 module** then press the **Diagnostics** button.

The L2 Diagnostics screen includes the Module Power, Sensors, Control Valve State, Auxiliary Valve State, Implement Switch, and Agitation Valve.



---

**Control Valve:****PWM Valve**

**Open** – Open graphic will indicate the active commanded duty cycle

**Closed** – Closed graphic will remain zero

**Servo Valve**

**Open** – Open graphic indicates what the system is commanding the product control valve to open.

**Closed** – Closed graphic indicates what the system is commanding the product control valve to close.

**Auxiliary Valves**

**Aux 1** – Displays the state of the valve

**Aux 2** – Displays the state of the valve

**Implement Switch** – When dot is green it is not available.

**Module Power:**

**ECU** – Displays voltage at the ECU

**High Power** – Displays voltage of the main power source

**Sensors:**

**Main Pressure** – Displays voltage of the Main pressure sensor.

**Aux Pressure** – Displays voltage of the Auxiliary pressure sensor.

**Agitation Pressure or Temperature** – Displays voltage of the pressure or temp sensor

Flow meter 1 and 2 – Displays the current frequency generated by the flow meter during application. Provides a running pulse count of the flow meter during application. Helpful to monitor feedback to the system from the flow meter.

# RightSpot Diagnostics

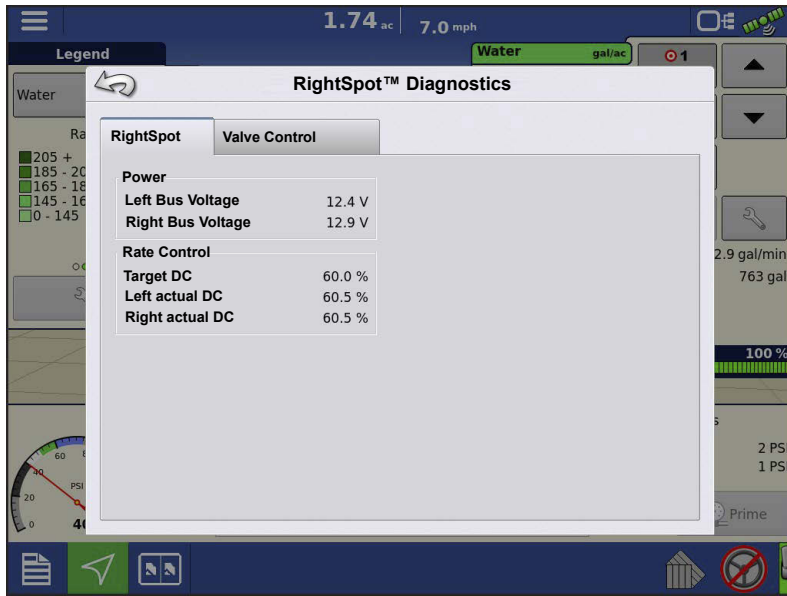

To go to the RightSpot Diagnostics screen, press



At the Devices screen, highlight the item marked **RightSpot Module** then press the **Diagnostics** button.

## Valve Control Modules

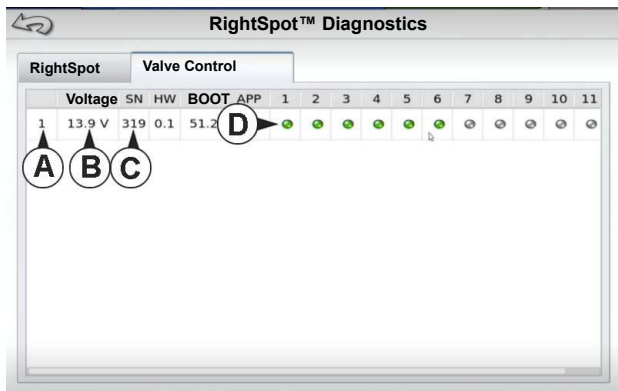

VCM diagnostics indicates

- A. Number of VCMs that are present
- B. Voltage from that VCM
- C. Serial Number
- D. Number of nozzles present on that VCM. Each VCM can only have 12 nozzles. (6 to the left and 6 to the right)

Green – valve coil is connected

Gray – valve coil is not connected

Red – valve coil has an active alarm

## Vehicle Interface Diagnostics

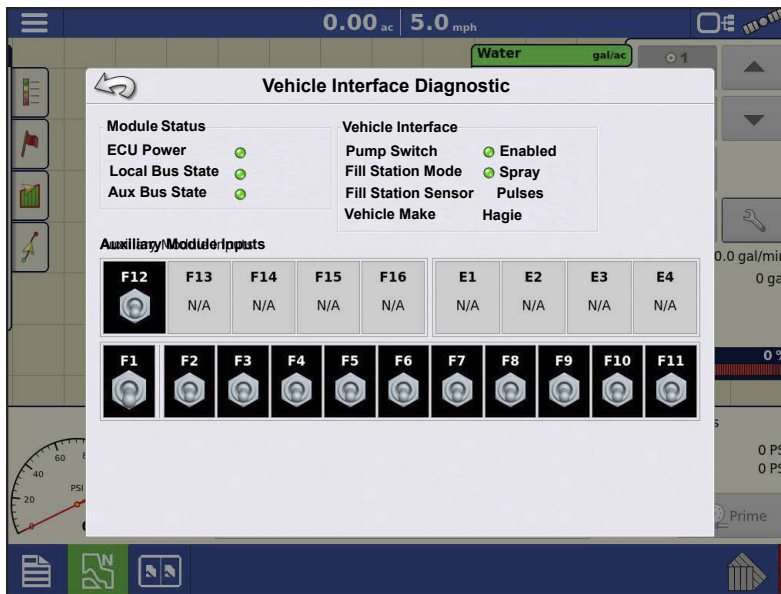

To go to the Vehicle Interface Diagnostics screen, press



**NOTE!** Vehicle Interface Module (VIM) is not required for every machine.

**ECU Power:** Indicates the voltage from the VIM module.

- Green – 10V and higher
- Yellow – 9.9 and lower

**Local Bus State:** Indicates Local Bus communication

- Green – Communication present
- Red – No Communication
- Yellow - Passive – No communication from the VIM

Check Cabling

Check Cabling

**Aux Bus State:** Indicates Auxiliary communication

- Green – Communication present
- Red – No Communication
- Yellow - Passive – No communication with the VIM to Auxiliary module if present

Check Cabling

Check Cabling

**Pump Switch:**

- Green – Pump Switch Enabled
- Yellow – Pump Switch Disabled

---

**Fill Station Mode**

- Green – Spray
- Yellow – Fill

When in Fill mode an alarm will also sound, indicating Fill Station is in fill mode.

**Mode:**

- Red – Indicates switch box is unknown
- Green – Indicates switch box is known. It will also display the brand. (Ex, Hagie – indicating the Hagie Hydro Handle is the controlling switch box)

**L2 Liquid Rate Controller LEDs****High Current LED**

Status	Definition
Off	No Power
Solid Red	Low Voltage
Solid Green	Power OK

**LED 1– Local CAN Communication**

Status	Definition
Off	CAN Bus Idle
Solid Red	CAN Bus Off
Solid Yellow	Passive BUS Error when no other devices are acknowledging.
Blinking Yellow	Active BUS Error when other devices are transmitting/receiving.
Blinking Green	Local CAN Bus Communicating with swath module

**LED 2– CAN Communication**

Status	Definition
Off	CAN Bus Idle
Solid Red	CAN Bus Off
Solid Yellow	Passive BUS Error when no other devices are acknowledging.
Blinking Yellow	Active BUS Error when other devices are transmitting/receiving.
Blinking Green	CAN Bus Communicating

## Liquid Swath Module

### High Current LED

Status	Definition
Off	No Power
Solid Red	Low Voltage
Solid Green	Power OK

### LED 1 – Local CAN Communication

Status	Definition
Off	CAN Bus Idle
Solid Red	CAN Bus Off
Solid Yellow	Passive BUS Error when no other devices are acknowledging
Blinking Yellow	Active BUS Error when other devices are transmitting/receiving
Blinking Green	Local CAN Bus Communicating with L2 Rate Controller

### LED 2 – Local CAN Communication

Status	Definition
Off	Standard Working State

## RightSpot Hub

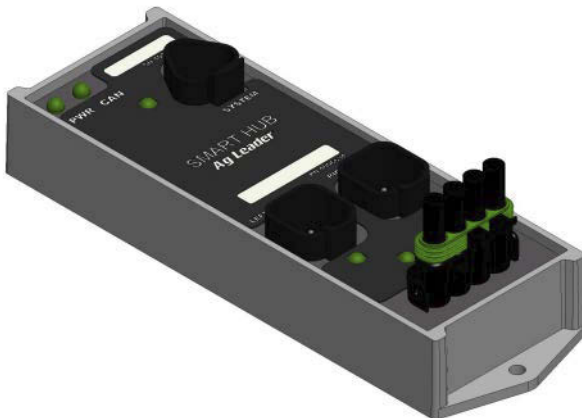

### LED 1 – PWR

Status	Definition
Green	High Current power present
Off	No power

## LED 2 – CAN Communication

Status	Definition
Off	No CAN Communication
Blinking Amber	Boot Loader or Upgrading
Green	CAN Communication Present

## LED 3, 4, and 5 – CAN Bus Communication

Status	Definition
Off	CAN Bus Idle
Solid Red	CAN Bus Off
Solid Amber	CAN Bus Error Passive
Blinking Amber	CAN Bus Error Active
Blinking Green	CAN Bus Communicating

## LED 6 and 7 – High Current Power

Status	Definition
Solid Green	High Current Power Present
Off	No Power

## Valve Control Modules



## LED 1 – High Current Power

Status	Definition
Solid Green	Power ON
Off	No power

**LED 2 – CAN Bus Status**

Status	Definition
Off	CAN Bus Idle
Solid Red	CAN Bus Off
Solid Amber	CAN Bus Error Passive when no other devices are acknowledging
Blinking Amber	CAN Bus Error Active when other devices are transmitting/receiving
Blinking Green	CAN Bus Communicating

**LED 3 – Valve Status**

Status	Definition
Off	Valves Off
Blinking Green	Valves Operating

**Troubleshooting RightSpot Application****Leaking or dripping when the valves should be shut off****Problem:**

Leaks at the nozzle/tip

**Cause:** Usually caused by contamination in the valve

**Solution:**

1. Ensure 80 mesh final filtration and clean filters
2. Inspect o-ring on the stem of the valve
  - If rolled, cracked, missing, or otherwise compromised, replace it
3. Disassembly the valve and clean it/rinse it out
4. Inspect the plunger sealing surface
  - If plunger seat is worn/compromised, replace plunger
  - If valve seat is worn/compromised, replace valve seat (orifice disk or flybody)

**Problem:** Leaks from around the flynut – not the nozzle/tip

**Cause:** Generally caused by a failure to seal of the larger, outer o ring in the valve body

**Solution:**

1. Confirm correct flybody or flynut type for nozzle body type

- 
- If correct, confirm that it is threading onto the nozzle body correctly and not cross-threaded
2. Confirm tight enough to not wiggle
  3. Ensure proper seating of outer o ring
    - Sometimes the o ring must be seated into the groove on the nozzle body rather than just held loose in the flybody
    - If not seated correctly, it may be pinched or otherwise compromised.

**Problem:** Leaks from between the flynut and coil

**Cause:** Generally caused by a missing O-ring or valve that is not sufficiently tightened onto the flybody

**Solution:**

1. Confirm the coil is tightened to a full stop onto the flybody.
2. If leaking still occurs, disassemble, and inspect o ring. Replace as needed.

**Problem:** Stuck/lodged plungers

**Cause:** Nearly always caused by contamination

**Solution:**

1. Disassemble and clean
2. Boom strainers and confirm 80 mesh final filtration
3. Consider chemical mix and mixing order
4. Avoid wettable powders and suspensions when possible
5. Increase water/carrier volume
6. Thoroughly rinse boom when switching chemicals to avoid chemical reactions that may result in precipitates or other unwanted by-products

**Problem:** Coil issues (short circuits, won't open, etc.)

**Solution:**

1. Measure resistance on the coil to confirm good.
  - 7W coils: 20-23.5 ohms
  - 12W coils: 10-13 ohms



---

If none of these lead to the root cause of the issue:

**Solution:**

1. Swap valves or valve parts from one valve to another (good to questionable) to see if the issue follows or not
2. Swap whole nozzle bodies with valves from one place to another (good to questionable) to see if the issue follows or not

**Problem:** Section indicators on the run screen of the display do not turn green.

**Solution:**

1. Make sure ground speed is registering a value greater than zero on the display.
2. Verify a target rate greater than zero is entered into the display.
3. Check the switch status found on the run screen under CAN and Input Diagnostics. As the boom switches are turned on and off, the Input Diagnostics window should change from black to green (if they do not, then refer to the installation instructions to verify boom switch connections).
4. Check high current connection into the L2 Rate Control Module.
5. Turn AutoSwath off.

**Problem:** AutoSwath turns on the boom too fast or too slow.

**Solution:**

1. Check GPS offsets in the vehicle setup to verify all the measurements are correct.
2. Verify implement offsets are appropriate for the sprayer.
3. Adjust the turn on look-ahead and turn off look-ahead to fine-tune Automatic Swath Control performance.
4. Verify Forward/Backward Section Offsets. If applicable - verify Section Offsets are correct if boom section(s) are independently offset.

**Problem:** No "As Applied" rate

**Solution:**

1. Check cabling from the channel connection of the L2 Rate Control Module to the flow meter.
2. Check flow meter for product buildup and proper operation.

---

**Problem:** Rate is erratic **Solution:**

1. Verify that the rate display smoothing option is check marked in the Equipment Settings of the Configuration Setup.
2. Check the controller settings of the active configuration. Verify that the valve settings are appropriate for the particular type of control valve being used.
3. Use manual valve control to see if the rate stays constant.

**Problem:** Erratic behavior from the flow meter and boom valves.

**Solution:**

1. Verify that the display firmware and module firmware are both current.
2. Verify that cabling has been installed correctly and that none of it has been pinched or damaged.

**Problem:** No boom pressure at the start of the field.

**Solution:**

1. Before product application begins, select Boom Prime and flip master switch on when ready to apply, or use manual valve control to build boom pressure. Select either Rate 1 or Rate 2 once pressure is set to desired level. Enter the pass and allow automatic control to take over once the sections are turned on.

**Problem:** AutoSwath checked on, but booms will not turn on.

**Solution:**

1. Make sure the ground speed is registering a value greater than zero on the display and not in previously covered area.
2. Make sure there is a target rate greater than 0.
3. Make sure the applicator is inside of the field boundary.
4. Verify the Master Switch icon is indicating On (green) and Off (red) appropriately.

**Problem:** Booms turn off in the middle of the pass.

**Solution:**

1. Check the display firmware and module firmware to see if they are the latest version released.

- 
2. Make sure the ground speed does not go to 0.
  3. Make sure the GPS is not losing the differential source.
  4. Verify that cabling has been installed correctly and that none of it has been pinched or damaged.

**Problem:** Rate not responding (error flashing)

**Solution:**

1. Make sure the flow meter calibration number matches the tag on the flow meter. For Raven flow meters, divide the calibration number by 10.
2. Make sure that the flow being applied is not greater than the pump can produce.
3. Use manual valve control to see if the control valve will open or close.
4. Check the tip manufacturer's charts to make sure they are in the operating range of the application.
5. Check for any product buildup in the flow meter.
6. Check product filter for debris.

**Problem:** Booms turn on when outside of the boundary.

**Solution:**

1. Make sure the Rate Outside of Field option is set to zero under the active configuration settings.
2. Make sure the Outside Boundary Option is set to Turn Section Off under the Automatic Swath Control options.
3. Make sure there is not a gap between the boundary and the first pass of the headlands.

**Problem:** Booms turn on briefly (less than a second) in the headlands (previously covered area)

**Solution:**

1. Make sure that the turn on look-ahead is greater than the turn off look-ahead.
2. Make sure GPS offsets are correct.
3. Make sure look-aheads are less than three seconds each.
4. Verify that the display and L2 Rate module are both updated to the latest available firmware.

---

## Control Valve Settings

### Liquid Product Control Valve Configuration Options

**Inline Servo** — Rate control is achieved through actuating a butterfly or ball valve found in the solution hose that goes to the booms. When the valve opens, the flow increases and when the valve closes, the flow decreases.

**Bypass Servo** — Rate control is achieved through actuating a butterfly or ball valve found in the return line to the solution tank. When the valve opens, the flow decreases and when the valve closes the flow increases.

**PWM 12 volt** — Rate control is achieved through speed changes to the solution pump. The PWM 12 Volt setting is programmed to pulse the power to an electric solenoid valve used to adjust the hydraulic flow to the solution pump.

**Pump Servo** — Rate control is achieved through speed changes to the solution pump. The pump servo setting is programmed to control an electric motor used to actuate a hydraulic valve to adjust the hydraulic flow to the solution pump.

**PWM Ground** — Rate control is achieved through speed changes to the solution pump. The PWM Ground setting is programmed to pulse the ground to an electric solenoid valve used to adjust the hydraulic flow to the solution pump.

**Calibrated Reflow** — Three-way boom valves are used to return product back to the tank in the off state. The returned flow is calibrated with adjustment at each valve. Calibration is required any time the nozzles are changed.

**Ramsey Valve** — A pneumatically-operated bypass valve. When air is supplied to the valve the rate increases; when air is released from the valve the rate decreases.

## Fertilizer default Product Settings

Material	Type	Abbreviated name for display and predefined name for SMS™	Percentage (in terms of lbs. 100 lbs.)			Density
			N	P(P <sub>2</sub> O <sub>5</sub> )	K (K <sub>2</sub> O)	
Anhydrous Ammonia	Liquid under pressure	NH <sub>3</sub>	82	0	0	5.14 lbs./gal. (at 60°F)
28% UAN	Liquid	28% UAN	28	0	0	10.67
30% UAN	Liquid	30% UAN	30	0	0	10.86 lbs./gal.
32% UAN	Liquid	32% UAN	32	0	0	11.06 lbs./gal.
Ammonium polyphosphate (starter)	Liquid	Ammonium polyphosphate	10	34	0	11.73 lbs./gal.

## Glossary of Application Settings

### Configuration Settings

**Rate Outside of Field**—Rate that will be used outside of the field boundary. **Zero** stops product application. **Last Good** uses the previous rate before exiting the boundary. **Rx Default** uses the default rate written in the prescription file loaded.

**Rate Display Smoothing**—Determines how the feedback from the control channel's rate sensor will be displayed on the run screen. When checked, the system will display the target rate when the application rate is within 10% of the target rate setting. When unchecked the system will display the raw feedback from the rate sensor.

**Minimum Flow**—This setting is used to maintain a consistent spray pattern. The display will not allow flow to drop below the entered setting. Set to flow at the lowest operating pressure for the selected spray tips with all sections on. When spraying with one or more boom sections off, the system automatically reduces the minimum flow setting according to the reduced spray width.

**Rate Change Look-Ahead**—Compensates for any delay in the control system when changing between different product flow rates during variable rate application. This setting can be thought of as a “look ahead” value when using a variable rate prescription. The display will send the signal to change rates before hitting a transition line so that the applied rate is correct when crossing into the new management zone. The typical setting range for this is 0-1 seconds.

---

## Speed Input Settings

**Primary Speed Source**—Main speed input source used by the display.

**Backup Speed Source**—If the primary speed source fails, the display will use the backup if one is available.

**Manual Speed**—If both of the speed input sources are unavailable, manual speed can be used in order for the control channel to provide application. Manual speed setting is for use during static machine testing or by the control system in the absence of primary and backup speed signals.

## Automatic Swath Control Settings

**Turn-On Look-Ahead**—Determines how far ahead the system looks to turn the swath sections back on. This setting compensates for any delay in the product control system when the sections are turned on.

**Turn-Off Look-Ahead**—Determines how far ahead the system looks to turn the swath sections off. This setting compensates for delay in the product control system when the boom sections are turned off.

**Outside Boundary Option**—Determines the behavior of the sections when exiting the field boundary or prescription-mapped area.

**Coverage Option**—Based on the coverage option selected, this setting determines the behavior of the swath section when entering/exiting an already applied area or field boundary. Options available include: Minimize Skip, Minimize Overlap, and User Defined Percentage.

## Auxiliary Input Settings

**Master Source** — Switch that performs global master control of all rate control channels.

**F1-F11** — Settings determine the switch(es) that will operate the controlling channel specified from the configuration setup.

**Assign**—Screen where switch(es) can be assigned to specific controlling channels. Single switches can be used to control multiple channels and swath sections.

---

## Controller Settings

**Flow Meter Cal** — Calibration value representing the number of pulses that equal one-gallon of product flow through the controlling system.

**Control Valve Settings** — Setting specifies the type of control valve being used for the rate control functions of the controlling system.

**Response Threshold** — Determines where the control channel switches between using Valve Response 1 and Valve Response 2 speed setting.

**Valve Response 1** — Determines the speed of the servo valve when product control error exceeds the Response Threshold setting. Valve Response 1 represents the fast speed of the servo valve.

**Valve Response 2** — Determines the speed of the servo valve when product control error is less than the Response Threshold setting. Valve Response 2 represents the slow speed of the servo valve.

**Flow Control Delay** — Setting for period of time from master switch on and the start of product application to the first flow control correction. This setting can be used to eliminate unwanted correction of flow control at the start of each pass. Typical setting values are zero for granular and 1 –2 seconds for liquid application control.

**Flow Control Valve**—When set to "Close" the controlling system shuts down when there is either a zero rate in the field or when entering an already-applied area. When set to "Hold" the controlling system remains in the last known state when all sections are shut off. If a PWM is the controlling system and the Flow Control Valve setting is set to "Hold" the valve will adjust to PWM Standby when all sections are shut off.

**Auxiliary Valve 1 & 2**—When all boom sections are off, this setting closes or opens an auxiliary valve. Choose settings for up to two auxiliary valves.

**PWM Frequency** — The frequency that the PWM control valve is pulsed at. Settings can be found from the manufacturer of the valve. Typical settings range from 100-125 Hz.

**PWM Gain** — Determines how aggressive the control valve responds when making rate change adjustments. The higher the value the more aggressive the system response is.

---

**Zero Flow Offset** — Represents the maximum duty cycle that is sent to the control valve without producing any hydraulic flow from the PWM valve. Using too high of a Zero Flow Offset value can cause the product control system to not properly control low rates or to shut off. See the PWM valve manufacturer information for recommended settings.

## Alarms

**Alarm:** Rate Not Responding

**Trigger Condition:** As-applied rate is outside user specified range for longer than user specified time.

**Clear Condition:** As-applied rate is within “good” range.

**Alarm:** Pressure Not Responding

**Trigger Condition:** Pressure is not within 10 psi for 5 seconds.

**Clear Condition:** Pressure returns to within 10 psi.

**Alarm:** SpitFire: High-Power Voltage Low

**Trigger Condition:** High Current power on LCM is below 10 volts.

**Clear Condition:** High-Power returns to normal.

**Alarm:** Swath Module: High-Power Voltage Low

**Trigger Condition:** High Current power on swath module is below 10 volts.

**Clear Condition:** High-Power returns to normal.

**Alarm:** Liquid Control Disabled: Cycle Master Switch

**Trigger Condition:**

- Event is loaded and master switch is “ON” state.

or

- System is controlling pump but pressure is not responding.

**Clear Condition:** Cleared when master switch is turned off.

**Alarm:** VCM: Low Voltage



---

**Trigger Condition:** VCM voltage is below 8.5 volts.

**Clear Condition:** Voltage is above 8.5 volts.

**Alarm:** Smart Hub Not Communicating

**Trigger Condition:** No CAN communication from Smart Hub.

**Clear Condition:** Smart Hub start communicating.

**Alarm:** VCM: Solenoid Open Circuit

**Trigger Condition:** Solenoid is not plugged in.

**Clear Condition:** Solenoid is plugged in and running for x seconds.

**Alarm:** VCM: Solenoid Short Circuit

**Trigger Condition:** Solenoid is shorted or power and ground to solenoid are shorted together

**Clear Condition:** Required power cycle to clear.

**Alarm:** VCM: Solenoid Lodged Closed

**Trigger Condition:** Plunger is stuck in closed position

**Alarm:** VCM: Solenoid Lodged Open

**Trigger Condition:** Plunger is stuck in open position



RightSpot enables automatic nozzle by nozzle swath control while maintaining consistent rate, pressure, and droplet size at every nozzle. RightSpot can increase productivity, reduce overlap, and achieve consistent results throughout a broad range of speed all while navigating challenging terrain such as contours and odd-shaped fields.

## General Guidelines

Some products tend to come out of suspension over time causing thick, slimy material to settle in the boom and inhibit proper nozzle valve functionality. When using these types of products it is a good practice to flush the boom with clean water when the sprayer won't operate for 6 or more hours.

Use the recommended chemical mixing order when filling the sprayer to avoid plugging screens and affecting nozzle valve functionality.

Avoid using wettable powder products in tank mixes and use liquid formulations when possible. Dry ingredients have a higher tendency of plugging screens and settling out in the boom which can affect nozzle valve functionality.

Use a minimum of 80 mesh screens to prevent debris from entering the boom that is large enough to obstruct nozzle valves. Inspect filters prior to starting the season and periodically throughout the season to ensure they are clean and undamaged.

Avoid cleaning VCMs and RightSpot Hub with high pressure water to prevent water from entering the connectors and damaging the modules.



**NOTE!:** Operating RightSpot above 60 psi will increase wear and reduce life expectancy of the plungers.

# RightSpot Universal Boom Layout

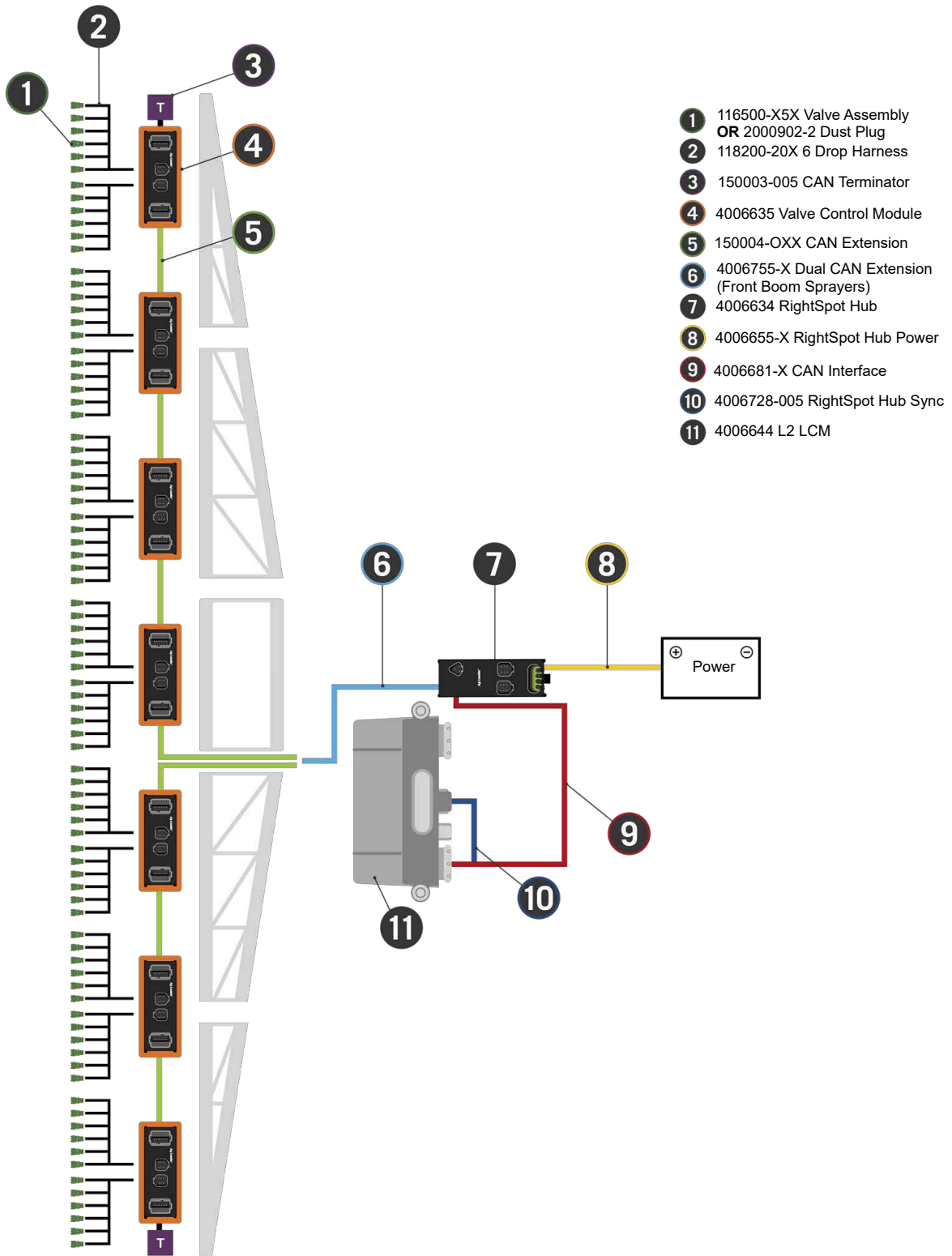

## Safety and Notices



**WARNING!** Read Feature User Guide completely before operating RightSpot.

Understand and follow all operating and safety instructions for proper use. Failure to use system properly could result in an impairment of the safety features of this product.

## Service and Support

Contact a local Ag Leader Dealer for assistance with RightSpot components. For Technical Support contact local dealer or Ag Leader Support at the number below.

ph: (515) 735-7000

e-mail: [support@agleader.com](mailto:support@agleader.com)

## System and Upgrades

Required software updates will be available free of charge for download automatically or can be manually downloaded at [www.agleader.com](http://www.agleader.com). It is recommended that the user check for available updates frequently to ensure display is updated.

## Automated Module Firmware Upgrade

In the display, all display and module firmware upgrades are packaged in a single .fw3 file. The module firmware files are stored internally in the display. A warning is shown when a module upgrade is required. All files can be upgraded in a single batch by using an upgrade screen.

## Product Registration

Ag Leader Technology products can be registered by one of the following methods. Registering allows the option of receiving notice of any new product updates or features.

Register at the Ag Leader Web site:

<http://www.agleader.com>

---

# Operator Safety

## Symbols

These symbols are used throughout the manual to designate where extra attention is necessary for the reader. The four symbols have following meaning.



**DANGER!:** This symbol means DANGER. Be very alert as safety is involved.



**WARNING!:** This symbol means WARNING. Be alert as safety can be involved.



**ATTENTION!:** This symbol means ATTENTION. This guides to better, easier and more safe operation.



**NOTE!:** This symbol means specific information applies.

## Precautions

Following these recommended precautions and safe operating practices before using the sprayer.

### General info



**DANGER!:** Read and understand this user guide before using the equipment. It is equally important that other operators of this equipment read and understand this user guide also.

If any portion of this user guide remains unclear after reading it, contact dealer for further explanation before using the equipment.



**DANGER!:** Keep children away from the equipment.

### Service



**DANGER!:** Never service or repair the equipment while it is operating. Always replace all safety devices or shields immediately after servicing.



**DANGER!:** Turn electrical power off before connecting and disconnecting the display and transducers, servicing or using a battery charger.



**DANGER!:** If an arc welder is used on the equipment or anything connected to the equipment, disconnect power leads before welding.



**DANGER!:** Do not use a high pressure cleaner to clean the electronic components.

## Nozzle Selection

New nozzles will be required to utilize RightSpot with Blended Pulse™. To identify the nozzle size appropriate for your sprayer and application rates, use the QR code or internet address, shown below, and reference the chart that matches your nozzle valve size and nozzle spacing. See [Nozzle Charts on page 1004](#) in this document for charts (Imperial and Metric) as an example.



A full list of nozzle charts can be found using the QR code shown.

[https://portal.agleader.com/community/s/article/6558?language=en\\_US](https://portal.agleader.com/community/s/article/6558?language=en_US)

1. Determine whether you have the Standard Valves or High Rate Valves.
2. Determine nozzle spacing.
3. Find the column with the desired target rate.
4. Locate the average operating speed.
5. Ensure the operating speed is within recommended pressure.
6. The nozzle size that falls into all 5 of the parameters above represents a good starting point for nozzle size selection. Be sure to reference the manufacturer's tip guide and the chemical label to ensure the specific tip with the intended rate & pressure used are appropriate for your application



**NOTE!** Air Induction (AI) Nozzles are typically not supported with PWM Nozzle Valve Systems like RightSpot. If an AI nozzle is desired, work with your nozzle manufacturer to ensure it is approved to work with PWM systems or uncheck Nozzle Pulsing and operate like a standard sprayer with individual nozzle section control



**NOTE!** Ag Leader is not responsible for selecting the nozzle tip used in an application. Use these charts as a tool prior to selecting the specific nozzle tip that meets the needs for proper application.

## Pre-Season Checklist

Before the season begins, review the checklist to ensure the system is ready for application.

- 
- Verify firmware is up to date for the display and modules.
  - Unfold the boom and inspect VCMs and cabling for wear or damage.
  - Remove a sample (5-10%) of the nozzle valve assemblies and inspect plunger seals for wear.
  - Inspect and clean all product filters, on the main product and boom lines. Verify all filters are minimum of 80 mesh and in good working condition.
  - Load configuration to the run screen to review RightSpot Hub Nozzle Controller Diagnostics
    - Check Voltage to the Left and Right Bus
    - Check status of connected VCMs and nozzle valves.
  - Perform a Boom Flush Routine. See [Boom Flush on page 993](#).
  - Verify Pressure Sensor
    - Check pressure reading on display compared to analog gauge on the boom (when applicable)
    - Look for erratic pressure readings (A sign of residue build-up on the sensor, a failing sensor, or a problem with cabling)
  - Verify flow meter calibration
    - Perform a nozzle catch test (Refer to RightSpot FUG)
    - Perform a large volume test using the Field Dispense Volume method
  - While spraying, toggle section switches on/off to verify proper nozzle assignment
  - Look for plugged nozzles, poor spray pattern, and leaks.

## Post-Season Checklist

After seasonal use, review the checklist to ensure RightSpot is adequately prepared for storage.

- Load clean water into the sprayer.
- Set target pressure to 50 psi
- Use manual valve control to increase nozzle duty cycle to 100% and flush entire boom with clean water.
- Cycle the valves between ~20% and 100% duty cycle until debris & residue are cleared.
- Winterizing: After the boom has been flushed with clean water, prime the boom with 100% RV antifreeze. The nozzle valves must be pulsed when priming to ensure antifreeze fills the coil and plunger cavity.





NOTE!: It is imperative that proper winterization is performed to prevent damaged parts during storage.



NOTE! Do not use fluid that will dry out o-rings and plunger seals. Typically alcohol based products.

---

## Maintenance

### Disassembling and Reassembling a Nozzle Valve Assembly

When inspecting and troubleshooting RightSpot, it will be necessary to remove and disassemble nozzle valve assemblies. The following instructions will guide the process.

#### Disassembling Nozzle Valves

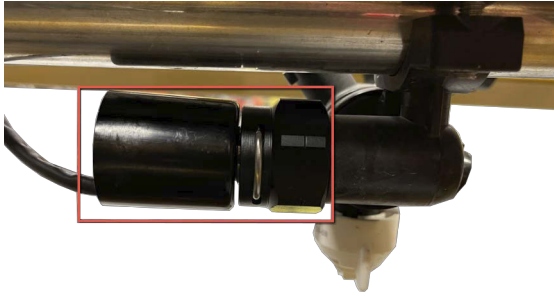

1. Remove the nozzle valve assembly from nozzle body by unscrewing the fly nut from the nozzle body. Hold the valve coil in place to prevent it from spinning.

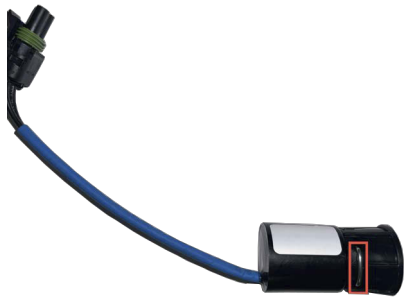

2. Remove the U-clip from the fly nut.



3. Remove the orifice insert.



4. Remove the plunger from the coil.

#### Items to Review

- a. Inspect plunger seal for excessive wear.
- b. Identify and remove debris located on the plunger seal and the mating orifice.
- c. Look for debris and built up product residual around the plunger and inside the valve coil.
- d. Inspect the spoke o-ring for damage

## Reassembling Nozzle Valves



1. Place plunger in the coil assembly.



2. Install the orifice insert. This will compress the plunger and slightly click into place. Ensure the spoke o-ring and orifice disk o-ring are installed and in good condition.



3. Slide the fly nut on the coil assembly and insert the U-clip to hold the fly nut in place.

4. Install nozzle valve assembly. Refer to the following section for proper installation.

## Nozzle Valve Assembly Installation

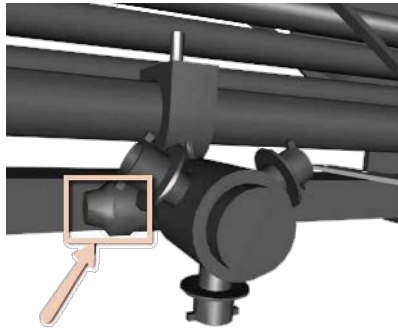

1. Remove the Drip Check from the existing Nozzle body.

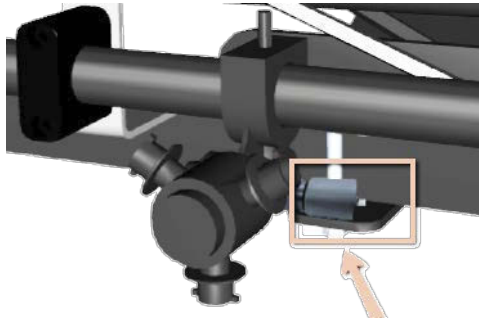

2. Thread the fly nut onto the nozzle body. Take care to avoid cross-threading. Hand tighten until there is a secure fit. When secure, the coil should not wobble. To prevent spoke o-ring damage avoid rotating the valve while threading on the fly nut.



**NOTE!** If leaking occurs through the nozzle tip or where the fly nut mates to the nozzle body, tighten the fly nut by  $\frac{1}{4}$  turn. Take care to prevent the coil from turning while tightening the fly nut. If leaking through the nozzle persists, remove and inspect the nozzle valve assembly. See [Troubleshooting on page 1001](#).

## Achieving Proper Coverage with Blended Pulse™

RightSpot is equipped with Ag Leader's DirectCommand L2 Rate Control Module and L2 Liquid Swath Control Module. The RightSpot Hub, Valve Control Modules (VCMs) and Nozzle Valve Assemblies are added to complete the RightSpot system.

RightSpot incorporates Blended Pulse™ technology. Blended Pulse™ is a feature that pulses adjacent nozzles in alternate timing to ensure proper spray coverage.

Below is a visual of the nozzle pulsing.

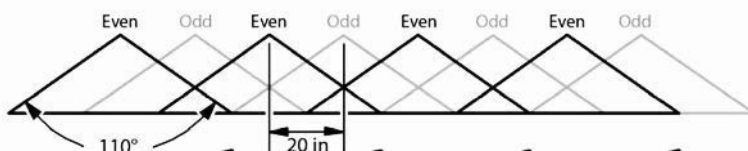

- Use wide-angle spray tips and appropriate boom heights to provide 100% nozzle overlap.

- For 80° tips, use 36 in or greater boom height. For 110° tips, use 24 in or greater boom height.
- Operate with a target pressure that allows the fan angle to be complete.
- Choose appropriately sized nozzles that achieve roughly 60% duty cycle at typical travel speed, boom pressure and target rate. See [Nozzle Selection on page 987](#).

## Boom Flush

Flushing the boom between applications and seasons helps prevent settled boom contents from affecting proper nozzle valve functionality. Boom flush routines are advised during the following:

- Changing products or modes of action
- Using thick syrup-like products
- Using products or mixes that tend to separate out of solution.

## Performing a static boom flush

- Fill the sprayer or rinse tank with water.
- Enter a manual ground speed that matches a typical operating speed.
- Enter a target rate
- Set target pressure to 50 psi
- Turn autoswath off.
- Turn all section switches and master switch on
- Put sprayer in manual control and increase the nozzle duty cycle to 100%
- Decrease duty cycle to ~20%
- Slowly transition between 100% to ~20% duty cycle until rinse is complete.

Initially flushing the boom using high pressure/flow with nozzle valves 100% open helps dislodge and purge settled residue in the boom and nozzle valves. Following up with pulsing nozzle valves helps flush residue and debris from the back and sides of the plunger.

## Cleaning Nozzle Valves

RightSpot was designed to monitor valve plunger status and will generate lodged open/closed alarms when the valve plungers aren't moving as expected. Lodged alarms indicate debris,

---

sediments, or syrup-like residue in the valve is preventing proper operation. To inspect and clean the valve perform the following steps:

1. Turn master switch off and disable sprayer pump.
2. Enable the section switch(es) associated with the nozzles needing attention. Turn off all other section switches.
3. Enter a manual speed, turn autoswath off, and turn on master switch to de-pressurize the boom sections. Turn off master switch when complete.
4. Remove the nozzle valve assembly.
5. With valve wire facing down, remove U-clip and fly nut.
6. Remove the orifice disk and inspect the plunger and coil for residue and debris.
7. Rinse the valve coil and plunger with clean water.
8. Reassemble the nozzle valve assembly and install on the nozzle body.

## Parts List

Ag Leader offers two versions of Nozzle Valve Assemblies. The Standard Valve accommodates most typical application rates and speeds while the High Rate Valve can be utilized when higher application rates are required.

### Standard Valve U-clip

**i NOTE!** If your largest nozzle size for maximum rate application is a 10 or less, a Standard Valve is the best choice.

Cover all surfaces of o-rings (D) and (F) with silicone lubricant.

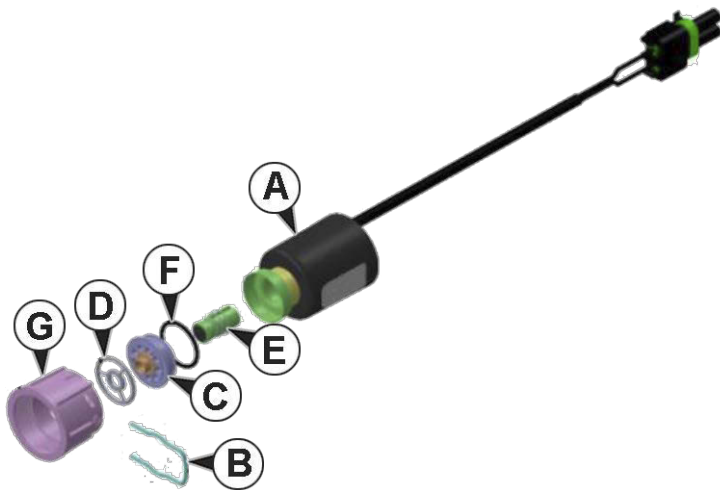

Coil Assembly Standard				
Item	Description	Tee Jet Part Number	Arag Part Number	Wilger Part Number
A	Coil Assembly 7W	116500-200	116500-200	116500-200
B	U-clip, Fly Nut	116500-222	116500-222	116500-222
C	Orifice Insert	116500-244	116500-243	3116500-244
D	O-ring, Spoke Common	116500-225	116500-225	116500-225
D	Plunger Assembly	116500-199	116500-199	16500-199
F	O-ring, orifice insert	116500-221	116500-221	116500-221
	Silicone Lubricant	116500-226	116500-226	116500-226
G	Flynut	116500-272	116500-271	116500-273

### High Rate Valve U-clip

Cover all surfaces of o-rings (D) and (F) with silicone lubricant.

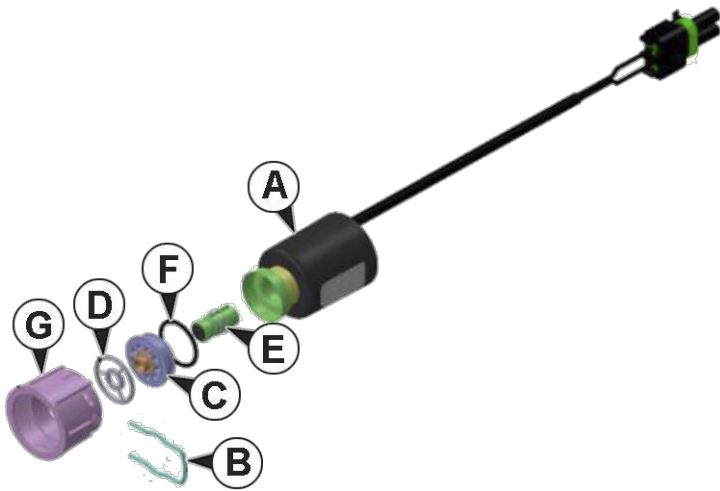

Coil Assembly High Rate				
Item	Description	Tee Jet Part Number	Arag Part Number	Wilger Part Number
A	Coil Assembly 12W	116500-300	116500-300	116500-300
B	U-clip, Fly Nut	116500-222	116500-222	116500-222
C	Orifice Insert	116500-246	116500-245	3116500-246
D	O-ring, Spoke Common	116500-225	116500-225	116500-225
E	Plunger Assembly	116500-199	116500-199	16500-199
F	O-ring, orifice insert	116500-221	116500-221	116500-221
	Silicone Lubricant	116500-226	116500-226	116500-226
G	Flynut	116500-272	116500-271	116500-273

### Service Parts and Kits for Valve Assembly.

Part Number	Description	Contents
116500-005	Service Kit - U-clip and Fly-Nut (TeeJet)	5pcs - 116500-222, 5pcs - 116500-272
116500-006	Service Kit - U-clip and Fly-Nut (Arag)	5pcs - 116500-222, 5pcs - 116500-271
116500-007	Service Kit - U-clip and Fly-Nut (Wilger)	5pcs - 116500-222, 5pcs - 116500-273
116500-008	Service Kit - 2 Slot Plunger	10pcs - 116500-199
116500-009	Service Kit - TJW15 Orifice Insert	10pcs - 116500-244
116500-010	Service Kit - A15 Orifice Insert	10pcs - 116500-243
116500-011	Service Kit - TJW24 Orifice Insert	10pcs - 116500-246
116500-012	Service Kit - A24 Orifice Insert	10pcs - 116500-245
116500-013	Service Kit - Spoke O-ring	10pcs - 116500-225
116500-014	Service Kit - Orifice Insert O-ring	10pcs - 116500-221
116500-200	Coil (7W)	1pc
116500-300	Coil (12W)	1pc



## RightSpot Hub

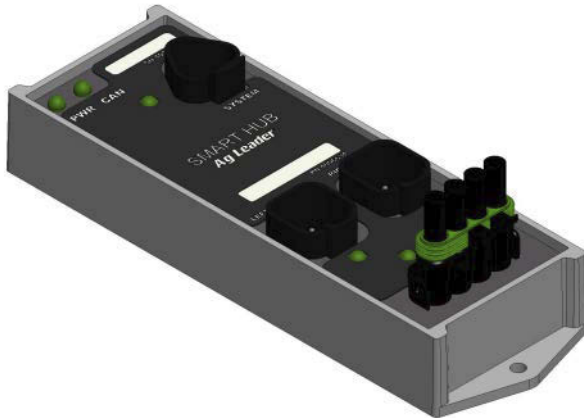

Item	Description	Part Number
1	RightSpot Hub Module	4006634

## Valve Control Module (VCM)



Item	Description	Part Number
1	Valve Control Module (VCM)	4006635

---

# Diagnostics

## L2 Liquid Rate Controller

### High Current LED

Status	Definition
Off	No Power
Solid Red	Low Voltage
Solid Green	Power OK

### LED 1– Local CAN Communication

Status	Definition
Off	CAN Bus Idle
Solid Red	CAN Bus Off
Solid Yellow	Passive BUS Error when no other devices are acknowledging.
Blinking Yellow	Active BUS Error when other devices are transmitting/receiving.
Blinking Green	Local CAN Bus Communicating with Swath Module

### LED 2– CAN Communication

Status	Definition
Off	CAN Bus Idle
Solid Red	CAN Bus Off
Solid Yellow	Passive BUS Error when no other devices are acknowledging.
Blinking Yellow	Active BUS Error when other devices are transmitting/receiving.
Blinking Green	CAN Bus Communicating

## Liquid Swath Module

### High Current LED

Status	Definition
Off	No Power
Solid Red	Low Voltage
Solid Green	Power OK

## LED 1 – Local CAN Status

Status	Definition
Off	CAN Bus Idle
Solid Red	CAN Bus Off
Solid Yellow	Passive BUS Error when no other devices are acknowledging
Blinking Yellow	Active BUS Error when other devices are transmitting/receiving
Blinking Green	Local CAN Bus Communicating with L2 Rate Controller

## LED 2– Local CAN Communication

Status	Definition
Off	Standard Working State

## RightSpot Hub

### LED 1 – PWR

Status	Definition
Green	High Current power present
Off	No power

### LED 2 – CAN Communication

Status	Definition
Off	No CAN Communication
Blinking Amber	Boot Loader or Upgrading
Solid Green	CAN Communication Present

### LED 3, 4, and 5– CAN Bus Status

Status	Definition
OFF	CAN Bus Idle
Solid Red	CAN Bus Off
Solid Amber	CAN Bus Error Passive
Blinking Amber	CAN Bus Error Active

### LED 6 and 7 – High Current Power

Status	Definition
Solid Green	Power On
OFF	No power

## Valve Control Modules

### LED 1 – Power

Status	Definition
Solid Green	Power ON
Off	No power

---

## LED 2 – CAN Bus Status

Status	Definition
Off	CAN Bus Idle
Solid Red	CAN Bus Off
Solid Amber	CAN Bus Error Passive when no other devices are acknowledging
Blinking Amber	CAN Bus Error Active when other devices are transmitting/receiving
Blinking Green	CAN Bus Communicating

## LED 3 – Valve Status

Status	Definition
Off	Valves Off
Blinking Green	Valves Operating

---

## Troubleshooting

### Problem: Leaking Valves

Valve leaks can occur either through the nozzle itself or where the valve assembly mates to the nozzle body.

**Problem:** Nozzle Leak – Typically due to debris lodged between the plunger seal and the orifice disk, excessive wear to the plunger seal, or damage to the orifice insert in the orifice disk.

1. Remove nozzle valve assembly and orifice disk. Inspect for contaminants, plunger wear, and damage to the spoke o-ring and orifice insert. Replace any worn or damaged parts, rinse with clean water and re-install.

**Problem:** Nozzle body/Coil Leak – Typically a result of the fly nut not being threaded on appropriately or a poor spoke o-ring seal.

1. Ensure fly nut is not cross-threaded on the nozzle body.
2. Tighten the fly nut ¼ turn and re-check for leaks.
3. If leaking continues, remove nozzle valve assembly and inspect spoke o-ring for damage and the orifice disk outer o-ring for damage or debris/residue. After inspection, cleaning, and replacing worn/damaged o-rings reinstall the nozzle valve and retest.

**Problem:** Lodged Plungers – A result of boom contamination.

1. Remove and disassemble nozzle valve assembly and clean.
2. Inspect strainers
3. Review [General Guidelines on page 983](#) and recommendations for [Boom Flush on page 993](#).

**Problem:** Coil Issues (Open/Short Circuit)

1. Measure resistance on the coil. Must be within the range specified below.
  - a. Standard Valve: 20-23.5 ohms
  - b. High Rate Valve: 10-13 ohms
2. If resistance is what should be expected, replace with a new nozzle valve assembly or coil assembly

- 
3. If the system still indicates an open/short circuit with that nozzle valve, check cabling from the VCM to the valve for damage and replace harness if needed.
  4. If after replacing harness there is still a coil open/short circuit, replace the VCM.

**Problem:** In ambient temperatures below 40F, the valves may generate lodged open alarms.

1. Check with area agronomist and add a non-ionic surfactant to tank mix.
2. Increase nozzle size if rate and chemical label allow.
3. Increase carrier volume to lower concentration of the tank mix.
4. Disable nozzle pulsing and switch to nozzles used for traditional flow control.

## Alarms

**Alarm:** Rate Not Responding

**Trigger Condition:** As-applied rate is outside user specified range for longer than user specified time

**Clear Condition:** As-applied rate is within "good" range

**Alarm:** Pressure Not Responding

**Trigger Condition:** The system pressure is at least 10 psi above or below the target or standby pressure for 5 seconds.

**Clear Condition:** Pressure returns to within 10 psi

**Alarm:** DirectCommand L2: High-Power Voltage Low

**Trigger Condition:** High Current power on LCM is below 10 volts

**Clear Condition:** High-Power returns to normal

**Alarm:** Swath Module x: High-Power Voltage Low

**Trigger Condition:** High Current power on swath module is below 10 volts.

**Clear Condition:** High-Power returns to normal

**Alarm:** Liquid Control Disabled: Cycle Master Switch

**Trigger Condition:** Event is loaded and system is unable to achieve the intended boom pressure.

**Clear Condition:** Pump is enabled and system can achieve intended pressure.

**Alarm:** VCM x: Low Voltage

**Trigger Condition:** VCM voltage is below 8.5 volts

**Clear Condition:** Voltage is above 8.5 volts

**Alarm:** RightSpot Hub Not Communicating

**Trigger Condition:** No CAN communication from RightSpot Hub to L2 Local Bus

**Clear Condition:** RightSpot Hub start communicating

**Alarm:** VCM: Solenoid Open Circuit

**Trigger Condition:** Solenoid is unplugged or there is a malfunction in cabling or connector between the coil and VCM.

**Clear Condition:** Nozzle Valve Coil is plugged in and detected.

**Alarm:** VCM: Solenoid Short Circuit

**Trigger Condition:** Nozzle Valve Coil is shorted or the two wire cable to nozzle valve is shorted.

**Clear Condition:** Short in nozzle valve coil or cabling is addressed.

**Alarm:** VCM: Solenoid Lodged Closed

**Trigger Condition:** Plunger is not moving as expected/commanded resulting in flow less than the intended amount for that nozzle valve.

**Clear Condition:** Plunger movement in alignment with what is expected/commanded.

**Alarm:** VCM: Solenoid Lodged Open

**Trigger Condition:** Plunger is not moving as expected/commanded resulting in flow higher than the intended amount for that nozzle valve.

**Clear Condition:** Plunger movement in alignment with what is expected/commanded.

# Nozzle Charts

## Standard (15 series), 20 Inch Nozzle Spacing

### Tip Sizes #6 — #15 Rate 15 GPA — 25 GPA

Tip Size	Gauge PSI	15 GPA			17.5 GPA			20 GPA			25 GPA		
		Min. MPH	MPH @ 60%	MPH @ 100%	Min. MPH	MPH @ 60%	MPH @ 100%	Min. MPH	MPH @ 60%	MPH @ 100%	Min. MPH	MPH @ 60%	MPH @ 100%
0.6 GPM #6	20	2	5	8	2	4	7	1	4	6	1	3	5
	30	2	6	10	2	5	8	2	4	7	1	3	6
	40	3	7	11	2	6	9	2	5	8	2	4	7
	50	3	7	12	3	6	11	2	6	9	2	4	7
	60	3	8	14	3	7	12	3	6	10	2	5	8
	70	4	9	15	3	8	13	3	7	11	2	5	9
0.8 GPM #8	20	2	6	10	2	5	9	2	4	7	1	4	6
	30	3	7	12	3	6	10	2	5	9	2	4	7
	40	4	8	14	3	7	12	3	6	11	2	5	8
	50	4	9	16	3	8	13	3	7	12	2	6	9
	60	4	10	17	4	9	15	3	8	13	3	6	10
	70	5	11	19	4	10	16	3	8	14	3	7	11
1.0 GPM #10	20	3	7	12	3	6	10	2	5	9	2	4	7
	30	4	9	14	3	7	12	3	6	11	2	5	9
	40	4	10	17	4	9	14	3	7	12	2	6	10
	50	5	11	19	4	10	16	3	8	14	3	7	11
	60	5	12	20	4	10	17	4	9	15	3	7	12
	70	6	13	22	5	11	19	4	10	17	3	8	13
1.2 GPM #12	20	3	8	13	3	7	11	2	6	10	2	5	8
	30	4	10	16	3	8	14	3	7	12	2	6	10
	40	5	11	19	4	10	16	4	8	14	3	7	11
	50	5	13	21	5	11	18	4	9	16	3	8	13
	60	6	14	23	5	12	20	4	10	17	3	8	14
	70	6	15	25	5	13	21	5	11	19	4	9	15
1.25 GPM #12.5	20	3	8	14	3	7	12	3	6	10	2	5	8
	30	4	10	17	4	9	14	3	8	13	3	6	10
	40	5	12	19	4	10	17	4	9	14	3	7	12
	50	5	13	22	5	11	18	4	10	16	3	8	13
	60	6	14	24	5	12	20	4	11	18	4	8	14
	70	6	15	25	5	13	22	5	11	19	4	9	15
1.5 GPM #15	20	4	9	15	3	8	13	3	7	11	2	5	9
	30	5	11	18	4	10	16	3	8	14	3	7	11
	40	5	13	21	5	11	18	4	10	16	3	8	13
	50	6	14	24	5	12	20	4	11	18	4	9	14
	60	7	16	26	6	13	22	5	12	20	4	9	16
	70	7	17	28	6	15	24	5	13	21	4	10	17



## Standard (15 series), 50 cm Nozzle Spacing

### Tip Sizes 01 #1 — 08 #8 Rate 50 L/Ha — 200 L/Ha

Tip Size	Gauge Bar	50 L/Ha			100 L/Ha			150 L/Ha			200 L/Ha		
		Min. KPH	KPH @ 60%	KPH @ 100%	Min. KPH	KPH @ 60%	KPH @ 100%	Min. KPH	KPH @ 60%	KPH @ 100%	Min. KPH	KPH @ 60%	KPH @ 100%
01 #1	1.0	1	3	6	0	2	3	0	1	2	0	1	1
	2.0	1	5	8	1	2	4	0	2	3	0	1	2
	3.0	1	6	9	1	3	5	0	2	3	0	1	2
	4.0	2	6	11	1	3	5	1	2	4	0	2	3
	5.0	2	7	12	1	4	6	1	2	4	0	2	3
	6.0	2	8	13	1	4	7	1	3	4	0	2	3
02 #2	1.0	2	7	11	1	3	6	1	2	4	0	2	3
	2.0	2	9	15	1	5	8	1	3	5	1	2	4
	3.0	3	11	19	1	6	9	1	4	6	1	3	5
	4.0	3	13	22	2	6	11	1	4	7	1	3	5
	5.0	4	15	24	2	7	12	1	5	8	1	4	6
	6.0	4	16	27	2	8	13	1	5	9	1	4	7
03 #3	1.0	2	10	16	1	5	8	1	3	5	1	2	4
	2.0	3	14	23	2	7	11	1	5	8	1	3	6
	3.0	4	17	28	2	8	14	1	6	9	1	4	7
	4.0	5	19	32	2	10	16	2	6	11	1	5	8
	5.0	5	21	36	3	11	18	2	7	12	1	5	9
	6.0	6	24	39	3	12	20	2	8	13	1	6	10
04 #4	1.0	3	13	22	2	7	11	1	4	7	1	3	5
	2.0	4	18	30	2	9	15	1	6	10	1	4	7
	3.0	5	22	37	3	11	18	2	7	12	1	5	9
	4.0	6	25	42	3	13	21	2	8	14	2	6	11
	5.0	7	28	47	4	14	24	2	9	16	2	7	12
	6.0	8	31	50+	4	15	26	3	10	17	2	8	13
05 #5	1.0	4	16	27	2	8	14	1	5	9	1	4	7
	2.0	5	22	37	3	11	18	2	7	12	1	5	9
	3.0	7	27	45	3	13	22	2	9	15	2	7	11
	4.0	8	31	50+	4	15	26	3	10	17	2	8	13
	5.0	9	35	50+	4	17	29	3	12	19	2	9	14
	6.0	9	38	50+	5	19	32	3	13	21	2	9	16
06 #6	1.0	5	20	33	2	10	16	2	7	11	1	5	8
	2.0	6	26	43	3	13	22	2	9	14	2	6	11
	3.0	8	32	50+	4	16	26	3	11	18	2	8	13
	4.0	9	36	50+	5	18	30	3	12	20	2	9	15
	5.0	10	41	50+	5	20	34	3	14	23	3	10	17
	6.0	11	45	50+	6	22	37	4	15	25	3	11	19
	7.0	12	48	50+	6	24	40	4	16	27	3	12	20
08 #8	1.0	7	26	44	3	13	22	2	9	15	2	7	11
	2.0	8	33	50+	4	16	27	3	11	18	2	8	14
	3.0	10	40	50+	5	20	33	3	13	22	2	10	17
	4.0	12	46	50+	6	23	38	4	15	26	3	12	19
	5.0	13	50+	50+	6	26	43	4	17	29	3	13	21
	6.0	14	50+	50+	7	28	47	5	19	31	4	14	24
	7.0	15	50+	50+	8	30	50+	5	20	34	4	15	25

## High Rate (24 series), 20 Inch Nozzle Spacing

### Tip Sizes #1 — #5 Rate 5 GPA — 12 GPA

Tip Size	Gauge PSI	5 GPA			7.5 GPA			10 GPA			12 GPA		
		Min. MPH	MPH @ 60%	MPH @ 100%	Min. MPH	MPH @ 60%	MPH @ 100%	Min. MPH	MPH @ 60%	MPH @ 100%	Min. MPH	MPH @ 60%	MPH @ 100%
0.1 GPM #1	20	1	3	4	1	2	3	1	1	2	0	1	2
	30	1	3	5	1	2	3	1	2	3	1	1	2
	40	1	4	6	1	2	4	1	2	3	1	1	2
	50	2	4	7	1	3	4	1	2	3	1	2	3
	60	2	4	7	1	3	5	1	2	4	1	2	3
	70	2	5	8	1	3	5	1	2	4	1	2	3
0.15 GPM #1.5	20	2	4	6	1	3	4	1	2	3	1	2	3
	30	2	5	8	1	3	5	1	2	4	1	2	3
	40	2	5	9	1	4	6	1	3	4	1	2	4
	50	2	6	10	2	4	7	1	3	5	1	2	4
	60	3	7	11	2	4	7	1	3	5	1	3	5
	70	3	7	12	2	5	8	1	4	6	1	3	5
0.2 GPM #2	20	2	5	8	1	3	6	1	3	4	1	2	3
	30	3	6	10	2	4	7	1	3	5	1	3	4
	40	3	7	12	2	5	8	1	4	6	1	3	5
	50	3	8	13	2	5	9	2	4	7	1	3	6
	60	4	9	14	2	6	10	2	4	7	2	4	6
	70	4	9	16	3	6	10	2	5	8	2	4	7
0.25 GPM #2.5	20	3	6	10	2	4	7	1	3	5	1	3	4
	30	3	8	13	2	5	9	2	4	6	1	3	5
	40	4	9	15	2	6	10	2	4	7	2	4	6
	50	4	10	17	3	7	11	2	5	8	2	4	7
	60	5	11	18	3	7	12	2	5	9	2	5	8
	70	5	12	20	3	8	13	2	6	10	2	5	8
0.3 GPM #3	20	3	8	13	2	5	8	2	4	6	1	3	5
	30	4	9	15	3	6	10	2	5	8	2	4	6
	40	4	11	18	3	7	12	2	5	9	2	4	7
	50	5	12	20	3	8	13	2	6	10	2	5	8
	60	5	13	22	4	9	14	3	6	11	2	5	9
	70	6	14	23	4	9	16	3	7	12	2	6	10
0.4 GPM #4	20	4	10	17	3	7	11	2	5	8	2	4	7
	30	5	12	20	3	8	14	3	6	10	2	5	8
	40	6	14	23	4	9	16	3	7	12	2	6	10
	50	7	16	26	4	10	17	3	8	13	3	7	11
	60	7	17	29	5	11	19	4	9	14	3	7	12
	70	8	19	30+	5	12	21	4	9	16	3	8	13
0.5 GPM #5	20	5	12	21	3	8	14	3	6	10	2	5	9
	30	6	15	25	4	10	17	3	8	13	3	6	10
	40	7	17	29	5	12	19	4	9	15	3	7	12
	50	8	20	30+	5	13	22	4	10	16	3	8	14
	60	9	21	30+	6	14	24	4	11	18	4	9	15
	70	10	23	30+	6	15	26	5	12	19	4	10	16

## High Rate (24 series), 50 cm Nozzle Spacing

### Tip Sizes 01 #1 — 08 #8 Rate 50 L/Ha — 200 L/Ha

Tip Size	Gauge Bar	50 L/Ha			100 L/Ha			150 L/Ha			200 L/Ha		
		Min. KPH	KPH @ 60%	KPH @ 100%	Min. KPH	KPH @ 60%	KPH @ 100%	Min. KPH	KPH @ 60%	KPH @ 100%	Min. KPH	KPH @ 60%	KPH @ 100%
01 #1	1.0	1	3	6	1	2	3	0	1	2	0	1	1
	2.0	2	5	8	1	2	4	1	2	3	0	1	2
	3.0	2	6	9	1	3	5	1	2	3	1	1	2
	4.0	3	6	11	1	3	5	1	2	4	1	2	3
	5.0	3	7	12	1	4	6	1	2	4	1	2	3
	6.0	3	8	13	2	4	7	1	3	4	1	2	3
02 #2	1.0	3	7	11	1	3	6	1	2	4	1	2	3
	2.0	4	9	15	2	5	8	1	3	5	1	2	4
	3.0	5	11	19	2	6	9	2	4	6	1	3	5
	4.0	5	13	22	3	7	11	2	4	7	1	3	5
	5.0	6	15	24	3	7	12	2	5	8	2	4	6
	6.0	7	16	27	3	8	13	2	5	9	2	4	7
03 #3	1.0	4	10	16	2	5	8	1	3	5	1	2	4
	2.0	6	14	23	3	7	12	2	5	8	1	3	6
	3.0	7	17	28	4	8	14	2	6	9	2	4	7
	4.0	8	19	32	4	10	16	3	6	11	2	5	8
	5.0	9	22	36	5	11	18	3	7	12	2	5	9
	6.0	10	24	40	5	12	20	3	8	13	2	6	10
04 #4	1.0	5	13	22	3	7	11	2	4	7	1	3	5
	2.0	7	18	30	4	9	15	2	6	10	2	4	7
	3.0	9	22	37	5	11	19	3	7	12	2	6	9
	4.0	11	26	43	5	13	22	4	9	14	3	6	11
	5.0	12	29	48	6	15	24	4	10	16	3	7	12
	6.0	13	32	50+	7	16	26	4	11	18	3	8	13
05 #5	1.0	7	16	27	3	8	14	2	5	9	2	4	7
	2.0	9	23	38	5	11	19	3	8	13	2	6	9
	3.0	12	28	46	6	14	23	4	9	15	3	7	12
	4.0	13	32	50+	7	16	27	4	11	18	3	8	13
	5.0	15	36	50+	7	18	30	5	12	20	4	9	15
	6.0	16	40	50+	8	20	33	5	13	22	4	10	16
06 #6	1.0	8	19	31	4	9	16	3	6	10	2	5	8
	2.0	11	27	45	6	14	23	4	9	15	3	7	11
	3.0	14	33	50+	7	16	27	5	11	18	3	8	14
	4.0	16	38	50+	8	19	32	5	13	21	4	10	16
	5.0	18	43	50+	9	21	36	6	14	24	4	11	18
	6.0	19	47	50+	10	23	39	6	16	26	5	12	19
	7.0	21	50+	50+	11	25	42	7	17	28	5	13	21
08 #8	1.0	10	25	41	5	12	21	3	8	14	3	6	10
	2.0	15	35	50+	7	18	29	5	12	20	4	9	15
	3.0	18	43	50+	9	22	36	6	14	24	4	11	18
	4.0	21	50	50+	10	25	42	7	17	28	5	12	21
	5.0	23	50+	50+	12	28	46	8	19	31	6	14	23
	6.0	25	50+	50+	13	31	50+	8	20	34	6	15	25
	7.0	27	50+	50+	14	33	50+	9	22	37	7	16	27



## Map View

Once a configuration has been completed and a field operation has been started, the Map View screen appears.

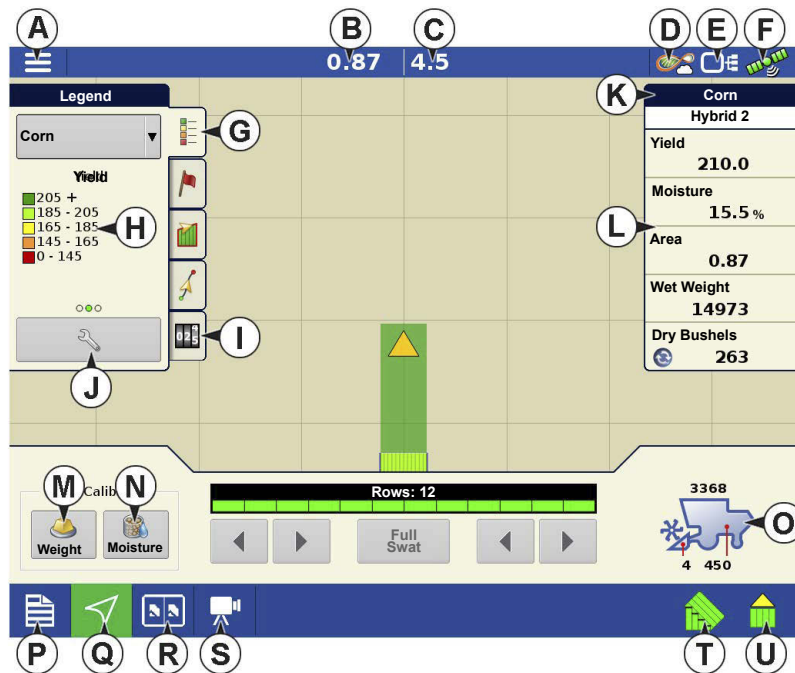

- A.Menu button
- B.Total Logged Field Area
- C.Ground Speed
- D.AgFiniti® Status Indicator
- E.Diagnostics Status Indicator
- F.GNSS Status Indicator
- G.Legend Tab
- H.Map Legend (varieties)
- I.Resettable Counter
- J.Legend Select
- K.Crop
- L.Status Items
- M.Weight Calibration, See [Grain Weight Calibration on page 1019](#).
- N.Moisture Calibration, See [Moisture Calibration on page 1022](#).
- O.Harvest Diagnostics
- P.Event Summary
- Q.Map View button
- R.Split screen
- S.Camera
- T.AutoSwath™
- U.Logging Status

Pressing the Map View button (M) will cycle between the available mapping screen views.

Corn	
Hybrid 2	
Yield	208.5
Moisture	18.0 %
Area	1.79
Wet	26262
Dry	469

## (L) Harvest Status Items

- **Yield** — Displays the instantaneous yield while there is grain flow and the average yield when grain flow is not present.
- **Moisture** — Displays the instantaneous moisture when there is grain flow and the average when there is no grain flow.
- **Area** — Shows the area harvested for the current region.

- **Wet Weight** — Shows the actual weight that has been harvested for the current region.
- **Wet Bushels** — Shows the actual bushels that have been harvested for the current region.
- **Dry Bushels** — Displays the actual number of bushels at the specified dry moisture percentage.
  - If the actual moisture is below the set dry moisture percentage and "Expand Bushels for All Grains Below Dry %" is not checked, it will show actual bushels.
  - If the actual moisture is below the set dry moisture percentage and "Expand Bushels for All Grains Below Dry %" is checked, it will display bushels as if the moisture of the grain is at the specified dry percentage.

The **Wet Bushels** and **Dry Bushels** Status Items do not appear if you are using metric system measurements.

## (O) Harvest Diagnostic Button on Map Screen

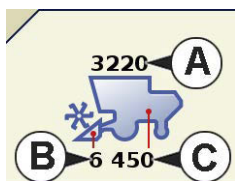

The Harvest Diagnostic button appears at the bottom right-hand portion of the Harvest Map screen. Pressing this button summons the Harvest Diagnostic screen.

- A. **Bushels Per Hour** — Bushels harvested per hour (bu/hr).
- B. **Header Height** — Percentage of header height.
- C. **Elevator Speed** — Revolutions Per Minute (RPM)

## (I) Resettable Counter

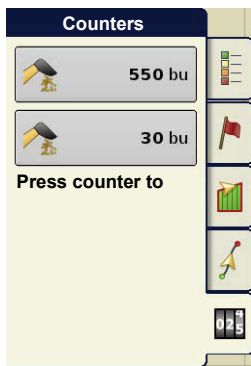

Resettable counters will automatically tally harvested crop any time that grain flow is seen.

- Counters keep tally based on crop type and will hold count through new events, fields, and product changes.
- Counters display wet weight bushels or pounds based on active crop type.
- Tap on the counter to reset to zero.

## Live Grain Tank Reset

The Grain Tank Reset Kit is used to track the combine's grain tank level using a proximity sensor and grain sensed by the flow sensor. With the kit installed, one of the existing bushel counters on the display will be the live counter. On initial fill, after starting a new event or power cycle, the system calibrates to determine the number of bushels beneath the sensor in the grain tank. This number is calculated using the main bushel counter to log the amount of grain entering the tank until the live grain tank sensor is covered. Once the sensor is covered, the live counter begins using the combine flow meter to calculate the amount of grain being added to the grain tank. On subsequent unloads, the live counter will reset to the calibrated number to provide an accurate bushel count. Without a calibrated value, an uncovered sensor shows a value of zero.

## Calibration of Live Grain Tank Reset Counter



- Empty grain tank and shut off unloading auger.
- Do not unload on the go. This causes some of the grain being unloaded to be added to the calibration value.
- Begin harvesting.
- Once the sensor is covered, the calibrated number will show on screen in the live counter.
- To update the initial calibration, tap the counter to reset the calibration. Repeat the calibration process during the next unload.

## Sharing Grain Tank Information with Grain Cart

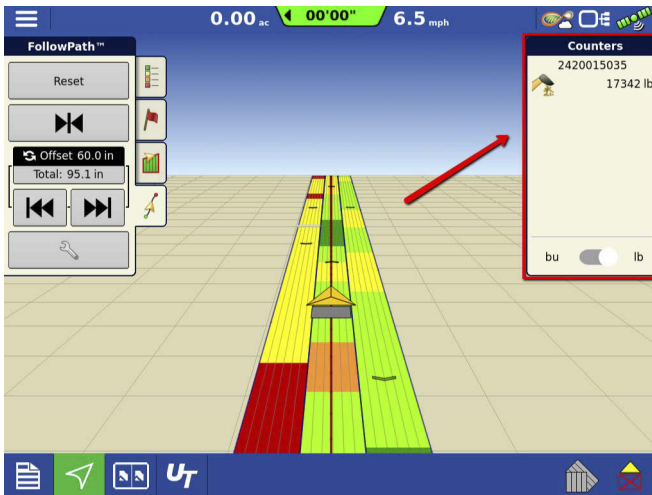

When the live grain tank sensor kit is present, the grain tank counter will be shared through DisplayCast and shown on screen in CartACE configurations. If multiple combines are present, they will be displayed as shown.

## Tracking Varieties (InCommand™ 1200 Only) and Changing Regions



Use the Options screen to enable the display to track varieties that were planted earlier and are now being harvested.

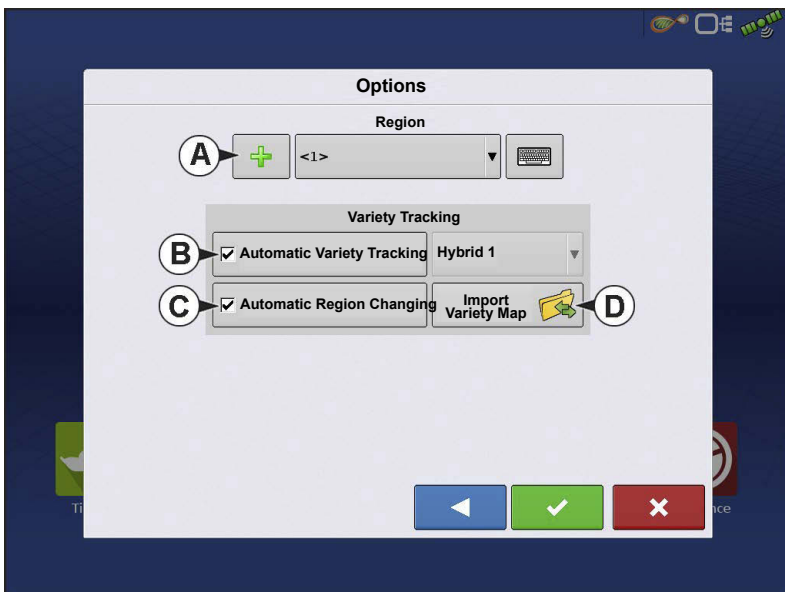

Types of variety tracking:

- Automatic Variety Tracking
- Automatic Region Changing.

The Options Screen is the last step before completing the harvest operational wizard. This can also be accessed from the Mapping screen by pressing the menu button followed by region.



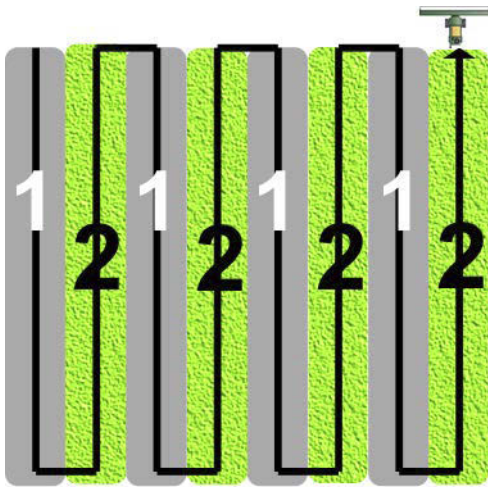

The illustration shows how the display could track two different varieties. In this example, when the harvester reaches the end of Variety 1, and moves to Variety 2, a message appears that either a new variety has been detected and the operator is notified to change regions (Automatic Variety Tracking,) or that a variety has been detected and the display is automatically changing regions. (Automatic Region Changing).

### (A) Region Selection

Press  to create new regions.

Use the drop-down to manually select or change regions.

### (B) Automatic Variety Tracking

Automatic Variety Tracking gives users the ability to track hybrids from planting/seeding operations during harvest. This gives quick access to yield information based on hybrids planted in the summary screen. Enable by checking the Automatic Variety Tracking box.

A variety map must be present to enable Automatic Variety Tracking.

If no variety map is present, then you can either

- (E) Manually assign a variety from the Variety Tracking List, located to the right of the Automatic Variety Tracking check box.

**OR**

- (D) Import a variety reference map.

### (C) Automatic Region Changing

To enable the Automatic Region Changing feature, select both the Automatic Variety Tracking check box, and the Automatic Region Changing check box. Automatic Region Changing will auto-sort varieties into regions as you go through the field.

- Automatic Region Changing tracks both varieties and regions, so the display changes the region automatically.

---

## In-Field Variety Tracking Messages



- With Automatic Variety Tracking selected, the message, “Variety detected. Go to the Region Selection screen to change Region and Variety” display’s each time the variety changes in the field. The message stays active until dismissed.
- With Automatic Region Changing selected a message noting the variety detected and region the display changed to appears each time the variety changes.

## (D) Importing Variety Maps

Variety maps can be imported from SMS™ software. SMS software uses planting data to create a variety reference map which is saved as an .AGSETUP file. This .AGSETUP file can then be exported to the display for use with the Automatic Variety Tracking and Automatic Region Changing features.

### Importing Variety Map Procedure

#### Select Reference File

The File Selection screen appears. Use  /  to scroll through the files and select the desired reference (.AGSETUP) file. Press  when finished.

### Error Messages at Variety Map Import

If the display failed to import a variety map, it is likely that one of three error messages appeared on the display:

**Error Message:** “Crop type of Variety Reference Map does not match crop type of field.”

**Possible Cause:** A different crop type was selected in the Harvest Operation Wizard than is shown in the variety reference map.

**Solution:** Either create a Harvest Operation with a different crop; or choose a variety reference map with an appropriate crop.

**Error Message:** “Variety Reference Map does not match location of field.”

**Possible Cause:** A different farm or field was selected in the Harvest Operation Wizard than is shown in the variety reference map.

**Solution:** Either create a Harvest Operation with a different field, or choose a variety reference map with an appropriate field.

**Error Message:** “Too many zones to show complete Variety Reference Map. Variety Tracking will work on all zones, even those not mapped on screen.”

**Possible Cause:** The reference file selected exceeded the allowable memory limit used to load reference maps.

**Solution:** Continue harvest operations. All variety tracking and region information will be logged. However, the entire reference map may not be visible on the display's Mapping screen.

### AutoSwath Sensitivity Settings

AutoSwath adjusts the swath width when crossing field boundaries and already-harvested areas. The display changes the swath width being harvested, even though no mechanical change takes place. AutoSwath is useful when harvesting point rows or where harvesting a full head width is not possible. When performing a Harvest operation, the AutoSwath feature includes sensitivity levels, which compensate for varying levels of GPS accuracy. If swath adjustments are performing inaccurately, adjust the sensitivity accordingly. Sensitivity 3 is the default setting. This setting is adjusted from the Configuration Setup menu.

Other settings include:

**Sensitivity 5** — Use with RTK or DGPS (GPS6500 RTK or TerraStar with SteerCommand®).

**Sensitivity 4** — Use with RTK or sub-meter DGPS. Terrain compensation recommended (GPS6000 or GPS6500 with Steering).

**Sensitivity 3** — Use with sub-meter accurate DGPS (most SBAS receivers like GPS6000).

**Sensitivity 2** — Use with 1+ meter accurate GPS.

**Sensitivity 1** — Swath sections are all on or all off. Use with 1+ meter accurate GPS.

### Map Options

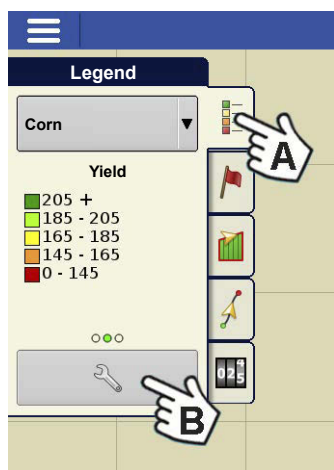

During Harvest operations, the Mapping screen displays three types of items in the Legend: Yield, Moisture, and Coverage.

The Legend Setup button on the Map Legend Tab of the Mapping Toolbox opens the Map Options screen.

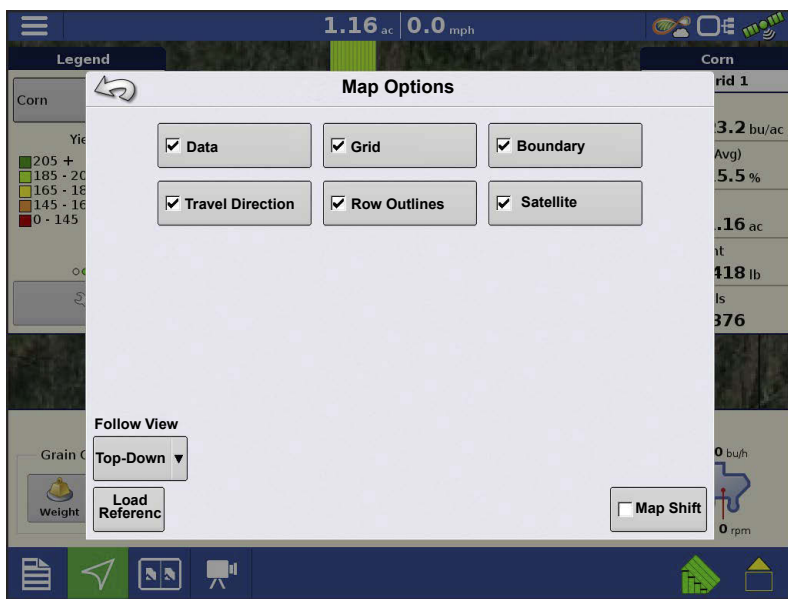

•Press Data, Guidance, Boundary, Marker, Reference, Grid, Travel Direction, and Row Outlines to show or hide those items on the Map screen.

•Press Clear Map to permanently remove all map data from the active field operation

•Press Load Reference to load a map from a previous operation performed in that field to view as a background map.

## Delay

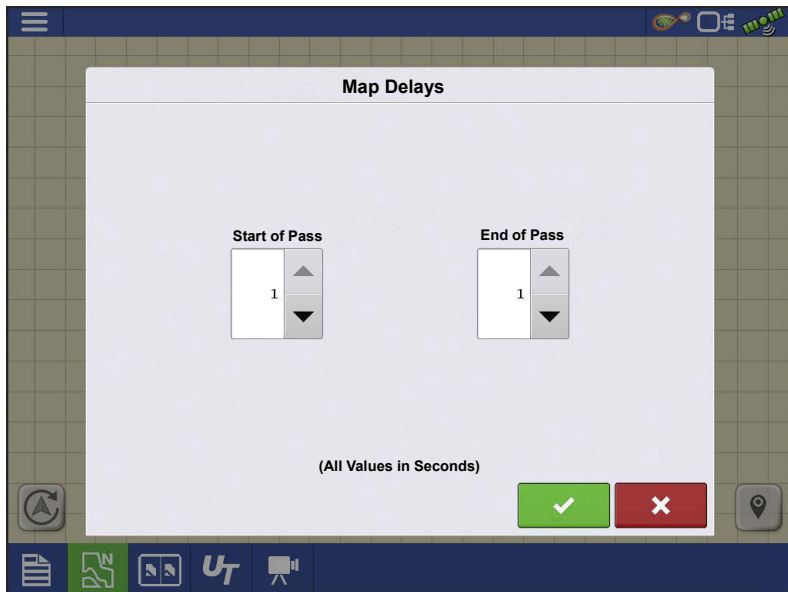

### •Start of Pass

The time between when the header is lowered and when the row starts. This compensates for a delay between when header is lowered and when it begins taking in the crop.

### •End of Pass

The time between when row ended and when the header is raised. This compensates for a delay between when the header finishes taking in the crop and when the header is raised.

## Create Configuration

A wizard is used to select or create a configuration that includes Combine, Header and Crops settings.

The configuration can be started in two places:



Upon completion, the Operating Configuration will then be viewable when starting a new Field Operation with the Harvest Operation Wizard.

The **Manage Equipment** button can be used to create or edit specific vehicles and implements.

## Load Configuration



Press the Harvest app from the home screen. Follow Field Operation wizard prompts to load the configuration to the Mapping screen.

## Harvest Calibration

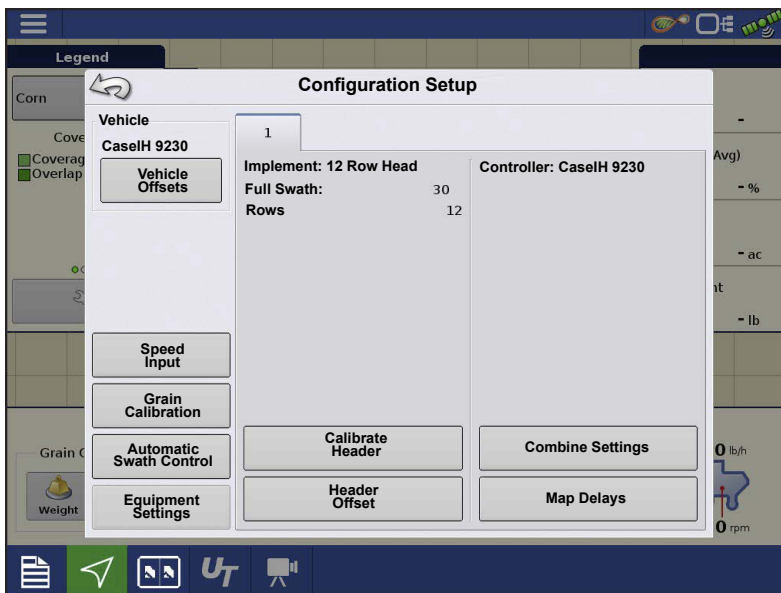

A configuration and harvest product specific calibrations must be completed before operating. The configuration setup page will show up as the last step of building a configuration.

Access configuration setup anytime from:



## Harvest Products

Grain weight calibrations are stored based on harvest products. A harvest product will need created for each crop type harvested. In some instances multiple harvest products per crop type may exist. In these instances each harvest product will require separate calibrations.

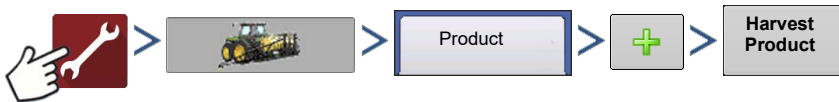

## Calibrate Header Height Sensor

Prior to logging data the combine header height sensor must be calibrated for the harvest product to be used. Follow the instructions shown on the screen from the Calibrate Header Sensor wizard.

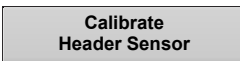

**NOTE!:** If Reset All is pressed the sensor will have to be calibrated for all headers!

## Calibrate Distance

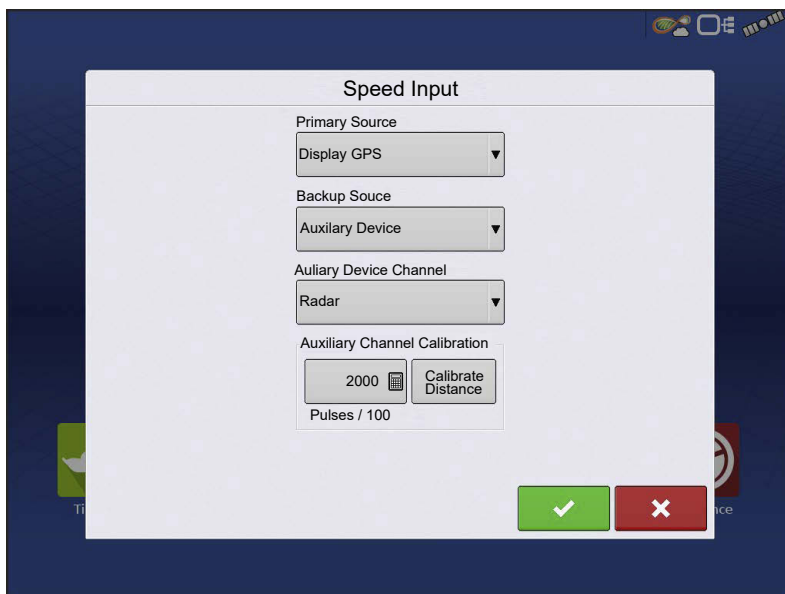

If you are not using GPS for ground speed, you must calibrate the ground speed input for accurate speed and area calculations. If you are using GPS, it is recommended to calibrate distance in the event of GPS loss. Follow the instructions shown on the screen.



 **NOTE!:** Calibration settings can be manually adjusted if desired by pressing button above Pulses/100 ft and making small changes to the setting.

### Vibration Calibration

Vibration Calibration must be performed with the correct head on the combine, and repeated for each harvest product used. This is prompted the first time a harvest product is loaded to the Mapping screen. From configuration setup go to:



1. **Run Separator** — Start the separator and feeder house with the proper header attached. Run at full speed.

 **NOTE!:** Do not harvest a crop during the Vibration Calibration process.

2. **Press Start** — With the combine separator running at full operating speed with the header engaged, press the Start button. The display counts down 60 seconds.
3. **Calibration Number Displayed** — When the vibration calibration is complete, a message appears underneath the Start button stating “Calibration Complete.” Next to this, the vibration calibration number is displayed. Press to return to the Calibration Tab. The separator may now be turned off.

 **NOTE!:** Rest of calibration accessed from mapping screen. See [Map View on page 1009](#).

### Grain Weight Calibration

To accurately measure harvested crop, the Ag Leader Yield Monitor must be calibrated. For each harvest product a calibration load/loads must be harvested and paired with the actual load weight measured by a weigh system. Weight calibration can be completed at any time during the season; however it is recommended that calibration be completed at the beginning of the season. Follow the calibration guidelines based on weigh device for best results.

#### Calibration Methods

Calibration can be completed with one or two calibration loads. More than two calibration loads are possible, but should not be needed in most cases.



**NOTE!:** One and Two load Calibration is only available on InCommand v2.5+ Displays.

### One Calibration Load

Accuracy good enough to see high/low yield trends in the field and make informed decisions based on yield. Accuracy is best when operating at normal operating grain flow rates.

### Two Calibration Loads

High quality accuracy through standard grain flow ranges.

Extra calibration loads (more than 2) can be entered for grain flow rates where more accuracy is desired.

### Calibration Load Flow Range

Follow suggestions based on how many calibration loads will be completed.

- **1st calibration load** – Harvest at normal full flow operating range for combine.
- **2nd calibration load** – Harvest at 50% normal operation range for combine
- Additional calibration loads –Harvest at Incremental speed/flow range changes excluding 1st and 2nd calibration load ranges

### Taking a Calibration Load

#### 1. Start new load

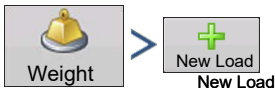

#### 2. Harvest calibration load

- a. Follow calibration load size suggestions based on weigh device used. See [Weigh Wagon Guidelines on page 1024](#).

#### 3. End calibration load



#### 4. Empty grain tank

- a. Empty the grain tank completely onto weight or transport device. Pay attention and verify all calibration load grain is accounted for.



5. Name calibration load

- a. Naming calibration loads is a simple way to track speed/flow range calibration load was taken at for later reference. Example: Combine Name-full flow
- b.  to change load name

6. Weight and record calibration load weight

- a. Record actual weight of calibration load taken from weigh device and enter

**Auto Calibration Weight Feature**



The AutoCal weight feature automatically adjusts grain weight calibration after an actual weight is entered into a calibration load, or a prior calibration load is checked/unchecked from the Weight Calibration page. AutoCal defaults to active. When AutoCal is unchecked the calibrate button must be pressed each time the calibration needs to be updated with new loads.

**Adding and Removing Calibration Loads within Existing Calibrations**

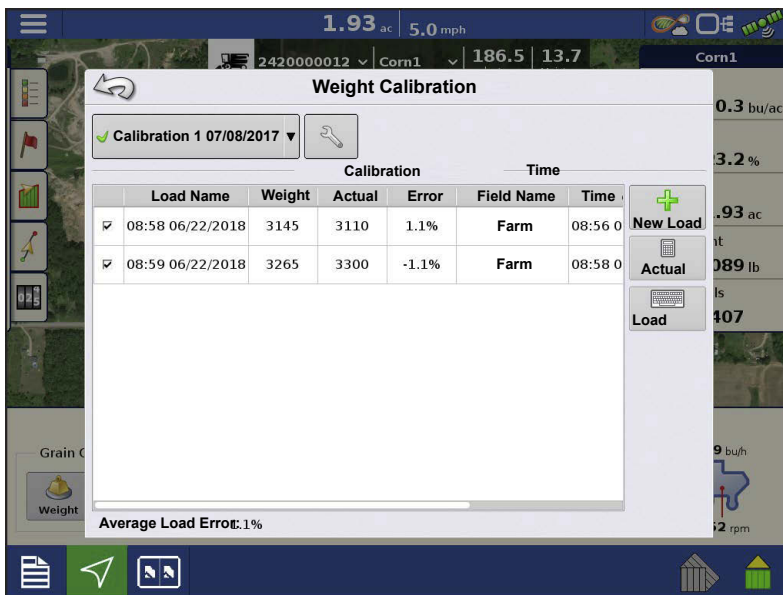

Calibration loads can be added or removed from the existing calibration at any time through the Weight Calibration page. This can be used to remove calibration loads taken that have a high error percentage or add calibration loads at specific flow ranges to improve calibration.

Only loads that are check marked are used in the active calibration.

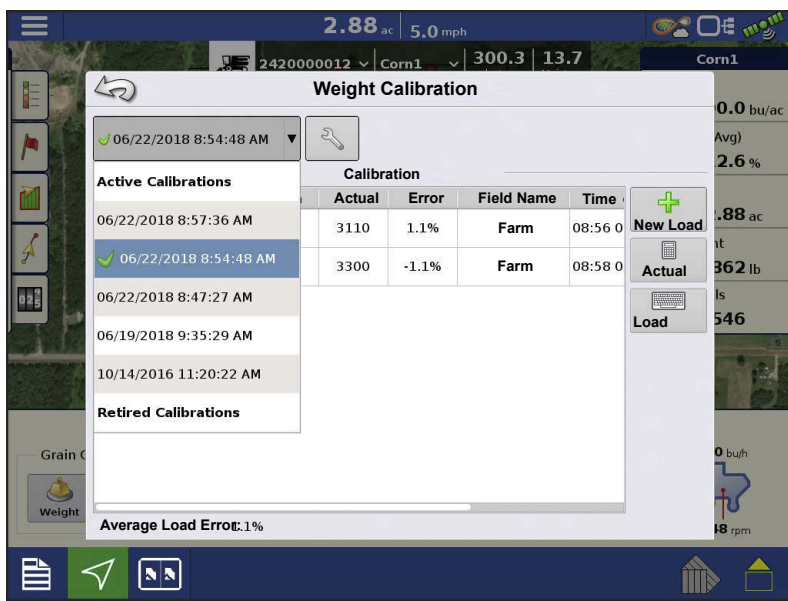



•The active weight calibration for a machine will have a green checkmark. Other active calibrations for other machines using DisplayCast will still be listed, but will not have the green checkmark. Retired calibrations will not sync over through DisplayCast.

**NOTE!** Only edit calibration loads that are within the weight calibration that has the green checkmark.

## Moisture Calibration



A moisture calibration only needs to be done once per crop, per season. Changing this calibration will affect all previously-harvested data.



1. **Measure Moisture on Grain Samples** — Randomly sample grain harvested into an active region, then measure moisture using an accurate moisture tester.
2. **Adjust Moisture** — On the Moisture Calibration screen, use  /  to adjust the moisture so that it matches the known moisture of the sample.

Press  when finished.

## Manual Moisture Setting



The “Use Manual Moisture” setting allows users to adjust moisture for a specific region. Unlike the Moisture Calibration, which affects all previously-harvested data, a Manual Moisture setting only affects data within a specified Region.

1. Check the Use Manual Moisture check box.
2. Use  /  to adjust the moisture to the desired value.

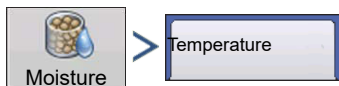

Press  when finished.

## Temperature Calibration



A Temperature Calibration only needs to be performed once per season. Changing this calibration will affect harvested data collected after the calibration.

Only calibrate the temperature before harvesting begins.

1. **Place Combine in Shady Spot** — Leave the combine parked in a shaded area or a shed for a few hours. The temperature calibration should not be performed if the sensor has been in direct sunlight.
2. **Take Air Temperature Reading** — Take an accurate air temperature reading using a thermometer in the same shaded area.
3. **Enter Outside Air Temperature** — Use  /  to enter the known outside air temperature. Make the proper adjustments until the Calibrated Temperature shown at the top of this screen reflects the correct air temperature.

Press  when finished.

## Retiring Calibration Loads



Harvest product calibrations can be retired. When pressed, all calibration loads associated with the harvest product will be removed from the system and a new calibration will be started. This will require a new vibration calibration, grain weight calibration, moisture calibration, and temperature calibration to be completed.

---

## Selecting Weigh Device

Calibration can be completed using either a certified scale, weigh wagon, or a grain cart with calibrated scales. Determine the weigh device that best fits the needs of the operation. For best results use the same weigh device throughout the calibration process of a harvest product.

### Certified Scale Guidelines

1. Calibration load size: 1 full combine grain tank.
2. Always start calibration loads with an empty combine and transport device.
3. Calibration loads must be transported and tracked separately from other harvested grain.
4. Avoid starting a calibration load opening a field or when switching between varieties.

### Weigh Wagon Guidelines

1. Calibration load size: 3000lbs up to weigh wagon max capacity.
2. Always start calibration loads with an empty combine and weigh device.
3. Use consistent load size for all calibration loads taken.
4. Entire calibration load must fit in weigh wagon without overfilling wagon or leaving grain in combine grain tank.
5. Unload from combine directly into weight wagon.
6. Avoid starting a calibration load opening a field or when switching between varieties.

### Grain Carts Guidelines

1. Calibration load size: 1 full combine grain tank.
2. Use consistent load size for all calibration loads.
3. Grain cart scale must be calibrated. Ideally calibration is/was completed using one full combine grain tank worth of grain. Recalibrating a grain cart is not the same as taring, or zeroing the scale. Follow calibration procedure within grain cart scale user manual.
4. Before starting a calibration load, make sure the combine and grain cart have harvested and dumped at least 10-20 bushel of grain to prime the augers.
5. Always start calibration load with an empty combine and weigh device.
6. Only unload in a grain cart sitting still. Weigh calibration load before grain cart is moved to dump.

7. Unload into the grain cart when on level ground. Ideally slope should be less than 3.5%.
8. Unload directly into the center of the grain cart to achieve symmetrical loading.

## Grain Cart Weighing Errors

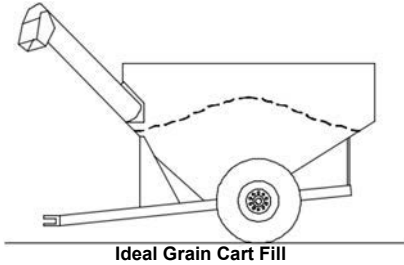

Grain carts with scales provide a convenient way for most operations to easily weigh calibration loads. Ag Leader has done extensive testing to understand how to get the best possible calibration accuracy when using grain cart scales. Through this testing many sources of error were discovered and documented.

Follow the guidelines above to minimize common errors when calibrating using a grain cart to achieve an ideal grain cart fill.



For more information see: [Grain Cart Weighing Errors](#)

[https://portal.agleader.com/community/s/article/2127?language=en\\_US](https://portal.agleader.com/community/s/article/2127?language=en_US)

# Harness Layout

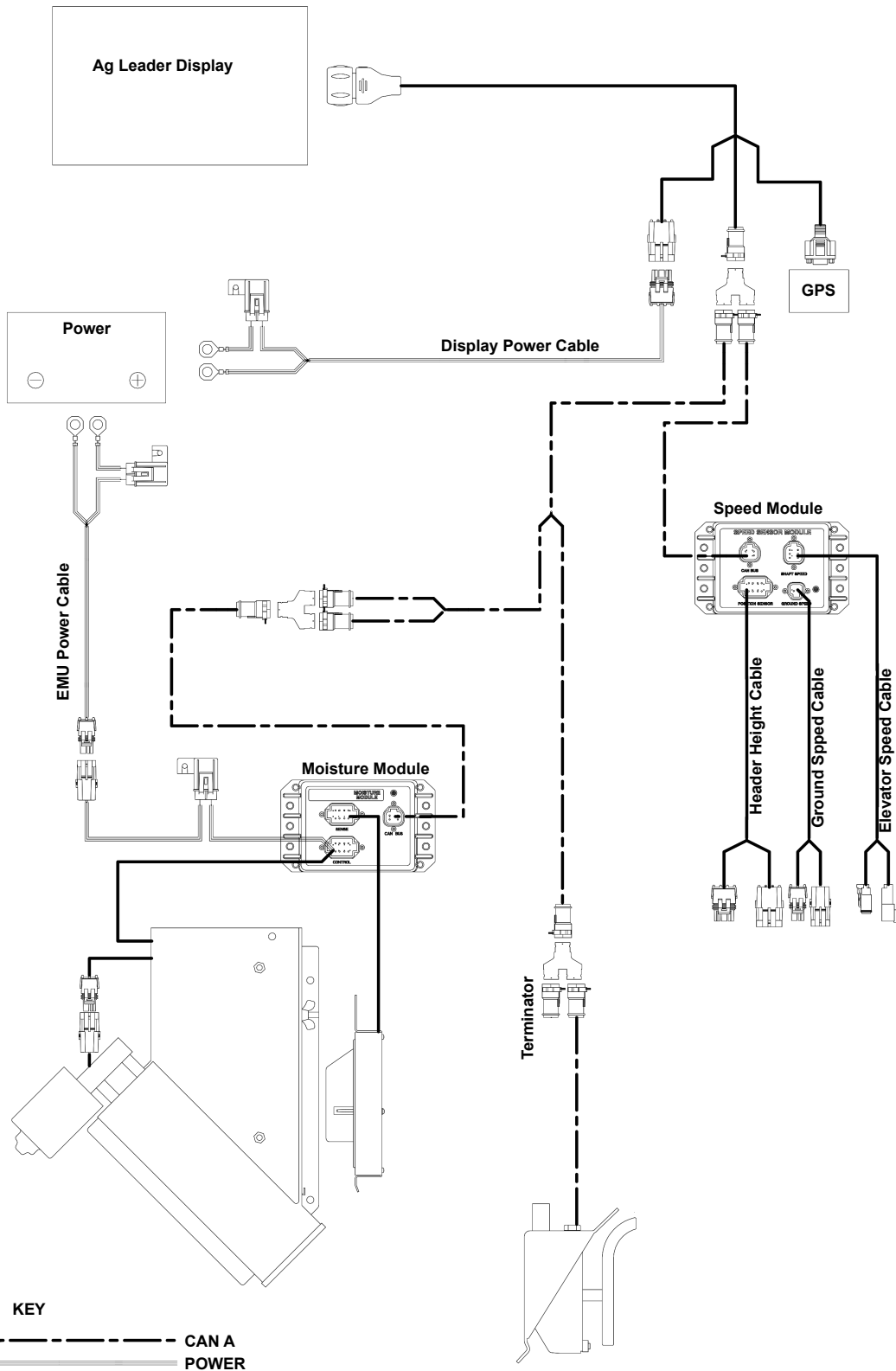

NOTE: Header Height, Ground Speed and Elevator Speed Cables may have different connectors than shown.

---

## Display Preparation

- Create display backup. Go to the Setup/Display menu to create a backup. Select Copy All Files to save the spring data to the USB Flash Drive or AgFiniti.
- Make sure your display firmware and all connected modules are up to date.
- If you have purchased a new combine or new heads, create new configurations for any setup that is different from last fall. Remove all old configurations.

Removing old configurations will remove data logged by that configuration from the display.

## Harvest Pre Season Checklist

When preparing your yield monitor system for harvest there are several items that need to be checked over before going to the field. Schedule time out well in advance so that replacement parts can be ordered and shipped before you have to go to the field. You may need to schedule services from your dealer or some equipment may need to be shipped to a central facility for repairs or upgrades.

1. Ag electronics get power from the combines batteries so pay special attention to the power system on the machine with a well maintained alternator/generator, inspect for clean electrical ground connections all around.
2. There are several yield monitor components that are interconnected by a cable harness. The wires in the harness need to be inspected for wear damage that may cause a short circuit. Start with the main power cable at the battery up to the monitor in the cab, and then back to each of the sensors.
3. The flow sensor is mounted in the top of the clean grain elevator. Check the elevator deflector and impact plate for wear. Verify you have the proper clearance at the top of the clean grain elevator. Clearance should be between 3/8" and 5/8" (0.95 cm to 1.59 cm). Verify proper installation and paddle clearance. Check for worn out or broken deflectors that channel the grain towards the sensor. Make sure that the impact plate is not worn thin or broken. You may want to look at a picture of a new one in the installation instructions to verify that everything is like it should be. Also be on the lookout for rodent damage to flow sensor wires on the load cell.
4. Next is the grain moisture/temperature sensor. Check for excessive wear and make sure the sensor is clean and free of mud or crop residue, also verify that you have good clean

---

electrical ground. The Ag Leader system uses a motorized auger to keep grain moving past the moisture sensor, check the fuse, switch and relay then verify that the auger turns free.

5. A header position sensor is mounted on the feeder-house of the combine. Check to make sure that the arm is attached properly so that it moves as the header is raised and lowered and that no wires are being pinched.
6. The elevator speed sensor is located on the end of the shaft that drives the clean grain elevator. Make sure that the tee cable is properly connected so that speed output is available to both the combine gauges and the yield monitor.
7. The ground speed sensor is located at the top of the transmission and also uses a tee cable to share speed output between the combine gauges and the yield monitor.
8. Check the Monitor/Display that it has the latest firmware (program) upgrades installed. Check for the proper date (this may indicate a problem with the internal battery) that it has the latest upgrades installed.
9. Make sure you have a working usb drive and that last years data is removed. Hook up the GPS receiver and get out in the open to verify that you are getting position and speed data to the yield monitor.



For more information see: [Harvest Pre Season Checklist](https://portal.agleader.com/community/s/article/1310?language=en_US).

[https://portal.agleader.com/community/s/article/1310?language=en\\_US](https://portal.agleader.com/community/s/article/1310?language=en_US)

## Grain Harvest Diagnostics

When performing a Harvest operation, access the Harvest Diagnostic screen by pressing (O) Harvest Diagnostic Button on the map screen.

Grain Harvest Diagnostics			
Region Distance		18257 ft	
Flow Rate	5.12	Moisture Raw	3.21
Flow Max	216	Temperature	-3.8
Flow Mn	172	Temperature Raw	2.69
Flow Offset	350	Proximity Status	ON
Sensor Force	9.95	Relay Status	ON
Header Raw	296	Motor Current	0.9
Speed Pulse	103		

The Grain Harvest Diagnostics screen includes the following information:

- **Flow Rate** — Grain flow rate
- **Flow Max, Flow Min and Flow Offset** — Raw flow values used for diagnostic purposes.
- **Sensor Force** — Force of grain flow
- **Header Raw** — Raw value of header sensor.



- 
- **Speed Pulses** — Number of ground speed pulses from the combine.
  - **Moisture Raw** — Raw value of moisture sensor.
  - **Temperature** — Air temperature
  - **Temperature Raw** — Raw value of temperature sensor.
  - **Proximity Sensor** — Shows if Elevator Mount Unit sensor is covered with grain.
  - **Relay Status** — shows on or off.
  - **Motor Current** — Measure of Elevator Mount Unit (EMU) current, shown in amps.

## Troubleshooting Flow

### No Flow

- Verify C1 value is between 0 and -100  
New vibration Calibration
- Verify C2-C11 is not zero  
Build new combine and configuration or use initial cal sheets to reset numbers.
- Check Elevator paddle clearance  
Should be 1/2in or 1.25in for Lexion Combines
- Check Cabling from Monitor to Flow Sensor
- Check for flow sensor damage from rodents
- Make sure deflector plate, impact plate, and flow sensor are installed correctly



For more information: [Troubleshooting-Harvest Flow Sensor \(Zero Flow\)](https://portal.agleader.com/community/s/article/1421?language=en_US)  
[https://portal.agleader.com/community/s/article/1421?language=en\\_US](https://portal.agleader.com/community/s/article/1421?language=en_US)

### High/Low Flow

- Verify Correct crop type has been selected
- Check elevator speed- should be around 400RPM and stable
- Grain flow is too low for sensor- take larger swath or drive faster
- Acres not being counted- Verify header stop height for crop type and elevator speed
- Verify differential GPS and secondary speed source has been calibrated
- Moisture calibration is too far off

Recalibrate moisture

- 
- Verify Weight/Volume value is set correctly per the crop type
  - “Expand Grain Below Dry” is set to Yes – change to No

## Moisture Troubleshooting

### Moisture is not changing

- Check to see if EMU motor is turning
- Check 5amp fuse near emu power connection
- Verify 12v power on EMU control cable 2pin connection on the fused line

Verify 30 amp fuse on EMU battery cable

- Verify EMU is clean of debris and grain can flow freely
- Plug battery power connection directly into EMU motor

This will verify that the emu motor is still good

- Adjust proximity switch

IF LED light on proximity switch comes on but the motor doesn't turn the moisture module may need replaced



For more information: [Troubleshooting - Harvest Moisture Sensor](https://portal.agleader.com/community/s/article/1418?language=en_US)

[https://portal.agleader.com/community/s/article/1418?language=en\\_US](https://portal.agleader.com/community/s/article/1418?language=en_US)

### Moisture is zero

- Check harvest diagnostics for raw moisture reading if value is present
- Verify temperature sensor is reading correctly

If -460 degrees moisture sensor is either unplugged or bad

## Adjusting Proximity Switch

1. Remove the cover from the elevator mount protecting the wiring.
2. Locate the adjustment screw on the back of the proximity switch.



**NOTE!** This screw sets the sensitivity of the switch.

3. Plug the power cable back into the elevator mount.

4. Use the small screwdriver that came with the Elevator mount unit and turn the adjustment screw COUNTER CLOCKWISE until the adjustment screw turns freely.



**ATTENTION!:** Adjusting the proximity switch is critical for the accurate operation of the moisture sensor.

5. Turn the adjustment screw CLOCKWISE until the auger motor comes ON with no grain in elevator mount.
6. Turn the adjustment screw back COUNTER CLOCKWISE three full turns and leave it set there.



For more information see: [Adjustment for Proximity Switch](#)

[https://portal.agleader.com/community/s/article/1250?language=en\\_US](https://portal.agleader.com/community/s/article/1250?language=en_US)

## Elevator Speed Troubleshooting

### No Speed

- Verify connection into proper sensor
- Check for cut or broken wires going from speed module to sensor
- Verify sensor is adjusted properly

This may require the combine manual or consulting the OEM dealer

- Check for power on combine side of elevator speed connector
- Check elevator speed channel

### Incorrect speed

- If A post speed and display speed are both incorrect

Ag Leader Tees into the elevator speed connector

Adjust elevator speed sensor

Remove Ag Leader connection to verify same issue with just combine cable connected

- If only Ag Leader sensor is incorrect

Check pulses/rev and # of sprocket teeth within combine settings

This should be set automatically based off of the combine chose within the configuration. Create new combine configuration and compare numbers between both configurations

---

### **Inconsistent speed**

- Verify good connections between elevator speed sensor and speed module

Many times poor system grounding or signal noise are causing for inconsistent elevator speed

- Verify sensor is adjusted properly

This may require the combine manual or consulting the OEM dealer

### **Header Height Troubleshooting**

- Verify Tee Cable connections are fully seated
- Header Height calibration has been completed
- If possible, verify header height sensor is appearing on the combine readout (A post)
- Header Channel is set properly

Channel 1: New Holland and Lexion combines

Channel 4: all other combines

- Check for Broken or binding header sensor rod ( Utilizing AG Leader header height sensor)

Manually move potentiometer rod

For more information: <https://dealer.agleader.com/kbp/index.php?View=entry&EntryID=960>

### **Ground Speed Troubleshooting**

- Verify speed source 1 and 2 are set properly — In most cases speed source 1 is GPS and 2 is wheel speed
- If utilizing wheel speed verify it is properly calibrated — Check wheel speed connections and cabling out to sensor

## Harvest Interface Module

The Harvest Interface module (HIM) is used on combines equipped with automatic yield calibration and threshing adjustments systems. These systems require the OEM yield monitoring to be fully functional to work correctly. The Harvest interface module logs and maps yield information generated by the OEM system to the Ag Leader display.

### Map View

Once a configuration has been completed, and a field operation has been started, the Map View screen appears.

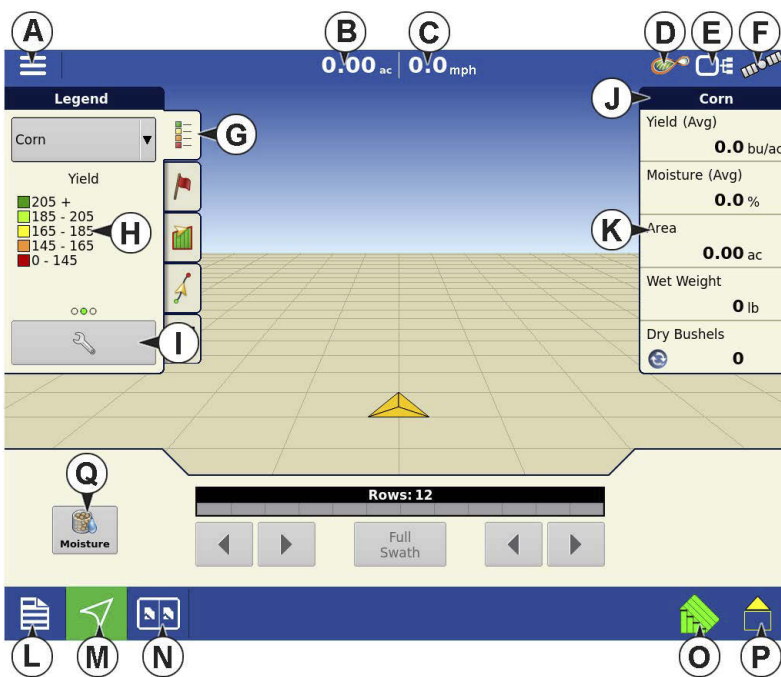

- A. Menu button
- B. Total Logged Field Area
- C. Ground Speed
- D. AgFiniti® Indicator
- E. Diagnostics Status Indicator
- F. GNSS Status Indicator
- G. Legend Tab
- H. Map (yield)
- I. Legend Select
- J. Crop
- K. Status Items
- L. Event Summary
- M. Map View button
- N. Split screen
- O. AutoSwath™
- P. Logging Status
- Q. Moisture Calibration



**NOTE!:** Pressing the Map View button (M) will cycle between the available mapping screen views.

## (K) Harvest Status Items

Corn	
Hybrid 2	
Yield	208.5
Moisture	18.0
Area	1.79
Wet Weight	26262
Dry Bushels	469

•**Yield** — Displays the instantaneous yield while there is grain flow and the average yield when grain flow is not present.

•**Moisture** — Displays the instantaneous moisture when there is grain flow and the average when there is no grain flow.

•**Area** — Shows the area harvested for the current region.

•**Wet Weight** — Shows the actual weight that has been harvested for the current region.

•**Wet Bushels** — Shows the actual bushels that have been harvested for the current region.

•**Dry Bushels** — Displays the actual number of bushels at the specified dry moisture percentage.

If the actual moisture is below the set dry moisture percentage and "Expand Bushels for All Grains Below Dry%" is checked, it will display bushels as if the moisture of the grain is at the specified dry percentage.



**NOTE!** The **Wet Bushels** and **Dry Bushels** Status Items do not appear if you are using metric system measurements

## Tracking Varieties and Changing Regions

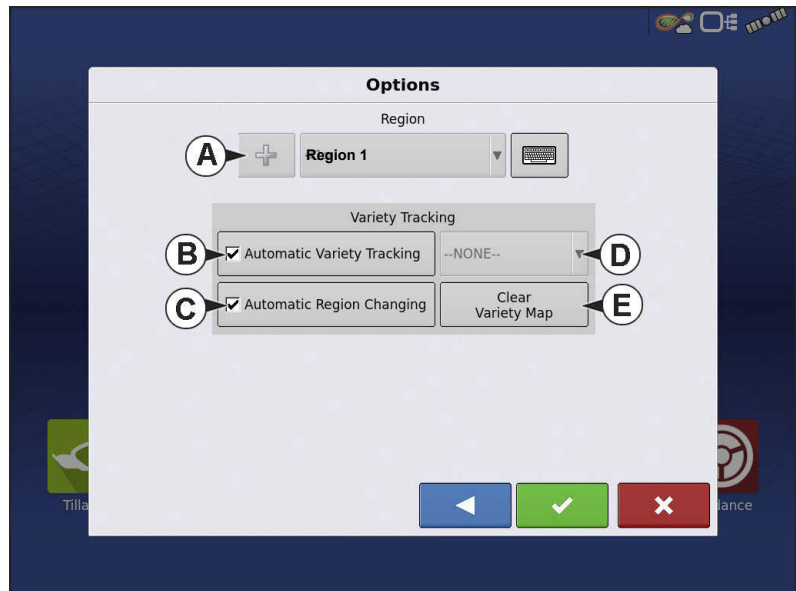

Use the Options screen to enable the display to track varieties that were planted earlier and are now being harvested.

The Options Screen is the last step before completing the harvest operational wizard. This can also be accessed from the Mapping screen by pressing the menu button followed by region.

Types of variety tracking:

- **Automatic Variety Tracking** — when a new variety is detected, operator is notified to change regions.
- **Automatic Region Changing** — when a new variety is detected, display automatically changes regions.

The illustration shows how the display could track two different varieties. In this example, when the harvester reaches the end of Variety 1, and moves to Variety 2, a message appears that either a new variety has been detected and the operator is notified to change regions (Automatic Variety Tracking,) or that a variety has been detected and the display is automatically changing regions. (Automatic Region Changing).

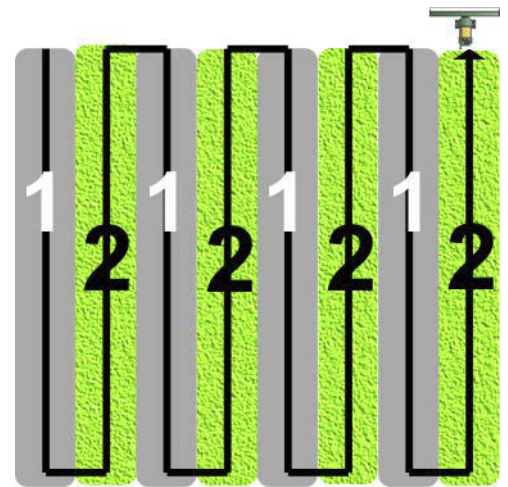

## (A) Region Selection

Press  to create new regions.

Use the drop-down to manually select or change regions.

## (B) Automatic Variety Tracking

Automatic Variety Tracking gives users the ability to track hybrids from planting/seeding operations during harvest. This gives quick access to yield information based on hybrids planted in the summary screen. Enable by checking the Automatic Variety Tracking box.



**NOTE!:** A variety map must be present to enable Automatic Variety Tracking.

If no variety map is present, then you can either

---

(D) Manually assign a variety from the Variety Tracking List, located to the right of the Automatic Variety Tracking check box.

**OR**

(E) Import a variety reference map.

## **(C) Automatic Region Changing**

If you wish to enable the Automatic Region Changing feature, select both the Automatic Variety Tracking check box, and the Automatic Region Changing check box. Automatic Region Changing will auto-sort varieties into regions as you go through the field.

- Automatic Region Changing tracks both varieties and regions, so the display changes the region automatically.

### **In-Field Variety Tracking Messages**

- With Automatic Variety Tracking selected, the message, “Variety detected. Go to the Region Selection screen to change Region and Variety” display’s each time the variety changes in the field. The message stays active until dismissed.
- With Automatic Region Changing selected a message noting the variety detected and region the display changed to appears each time the variety changes.

## **(E) Importing Variety Maps**

Variety maps can be imported from SMS™ software. The SMS software uses planting data to create a variety reference map which is saved as an .AGSETUP file. This .AGSETUP file can then be exported to the display for use with the Automatic Variety Tracking and Automatic Region Changing features.

### **Importing Variety Map Procedure**

#### **Select Reference File**

The File Selection screen appears. Use  /  to scroll through the files and select the desired reference (.AGSETUP) file. Press  when finished.

### **Error Messages at Variety Map Import**

If the display failed to import a variety map, it is likely that one of three error messages appears on the display:



**Error Message:** “Crop type of Variety Reference Map does not match crop type of field.”

**Possible Cause:** A different crop type was selected in the Harvest Operation Wizard than is shown in the variety reference map.

**Solution:** Either create a Harvest Operation with a different crop; or choose a variety reference map with an appropriate crop.

**Error Message:** “Variety Reference Map does not match location of field.”

**Possible Cause:** A different farm or field was selected in the Harvest Operation Wizard than is shown in the variety reference map.

**Solution:** Either create a Harvest Operation with a different field, or choose a variety reference map with an appropriate field.

**Error Message:** “Too many zones to show complete Variety Reference Map. Variety Tracking will work on all zones, even those not mapped on screen.”

**Possible Cause:** The reference file selected exceeded the allowable memory limit used to load reference maps.

**Solution:** Continue harvest operations. All variety tracking and region information will be logged. However, the entire reference map may not be visible on the display’s Mapping screen.

## AutoSwath Sensitivity Settings

AutoSwath adjusts the swath width when crossing field boundaries and already-harvested areas. The display changes the swath width being harvested, even though no mechanical change takes place. AutoSwath is useful when harvesting point rows or where harvesting a full head width is not possible. When performing a Harvest operation, the AutoSwath feature includes sensitivity levels, which compensate for varying levels of GPS accuracy. If swath adjustments are performing inaccurately, adjust the sensitivity accordingly. Sensitivity 3 is the default setting. This setting is adjusted from the Configuration Setup menu.

Other settings include:

**Sensitivity 5** — Use with RTK or DGPS

(GPS 6500/7500 RTK or TerraStar with SteerCommand)

**Sensitivity 4** — Use with RTK or sub-meter DGPS. Terrain compensation recommended

(GPS 6000/7000 or GPS 6500/7500 with Steering)

**Sensitivity 3** — Use with sub-meter accurate DGPS

(most SBAS receivers like GPS 6000/7000)

**Sensitivity 2** — Use with 1+ meter accurate GPS

**Sensitivity 1** — Swath sections are all on or all off. Use with 1+ meter accurate GPS

## Map Options

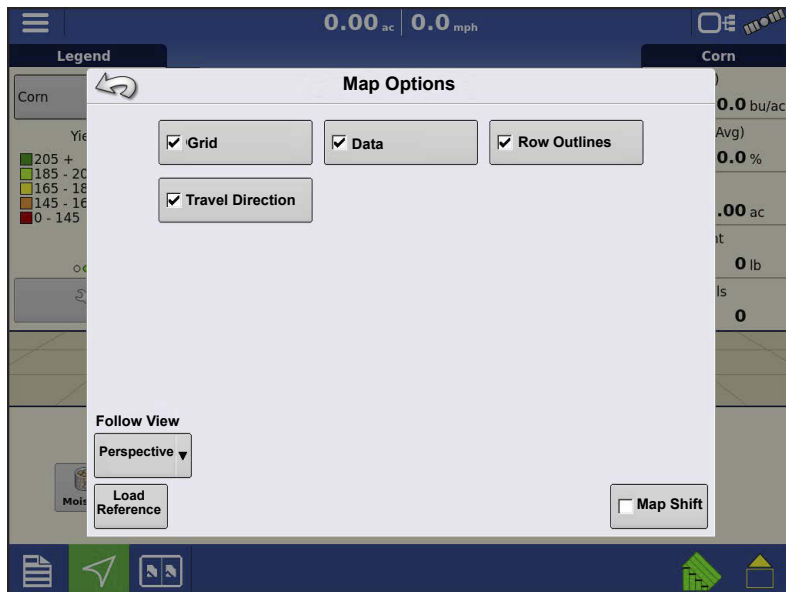
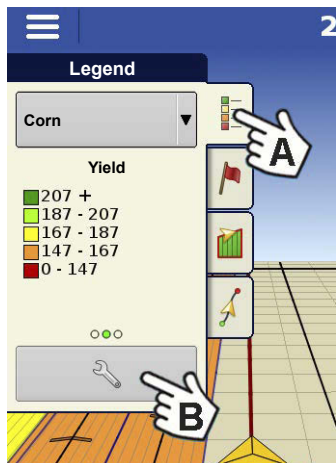

During Harvest operations, the Mapping screen displays three types of items in the Legend: Yield, Moisture, and Coverage.

The Legend Setup button on the Map Legend Tab of the Mapping Toolbox opens the Map Options screen.

- Press Data, Guidance, Boundary, Marker, Reference, Grid, Travel Direction, and Row Outlines to show or hide those items on the Map screen.
- Press Clear Map to permanently remove all map data from the active field operation
- Press Load Reference to load a map from a previous operation performed in that field to view as a background map.

Delay

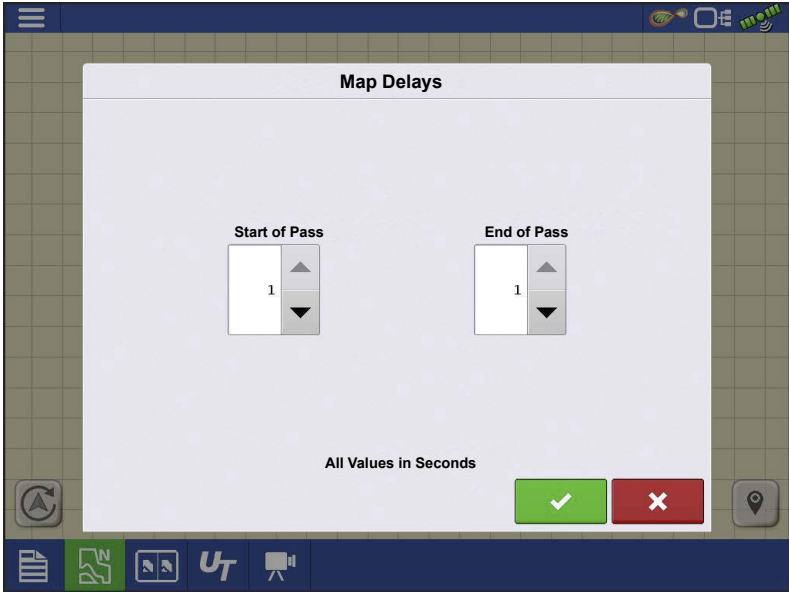

•Start of Pass

The time between when the header is lowered and when the row starts. This compensates for a delay between when header is lowered and when it begins taking in the crop.

•End of Pass

The time between when row ended and when the header is raised. This compensates for a delay between when the header finishes taking in the crop and when the header is raised.

Create Configuration

A wizard will guide you through the process of selecting or creating a configuration that includes Harvester, Header and Crops settings.

The configuration can be started in two places:

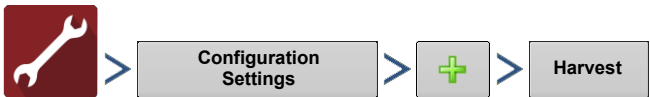

Upon completion, the Configuration will then be viewable when starting a new Field Operation with the Harvest



**NOTE!:** When creating a configuration be sure to select “Harvest Interface Module” as the harvest system type.



**NOTE!:** The **Manage Equipment** button can be used to create or edit specific vehicles and implements.

Your Operating Configuration will then be viewable when you start a new Field Operation with the Harvest Operation Wizard.

- Use swath width for a platform
- Use number of rows and row spacing for header

## Load Configuration



Press the harvest operations button from the home screen. This will take you through the steps needed to load a configuration.

## Calibration Information

When using the HIM, all grain weight calibration and adjustments are managed through the OEM monitor. Reference the OEM display documentation for all calibration procedures.

## Manual Moisture Setting

As with other calibration information, the Moisture Calibration is calculated in the OEM monitor and then relayed to the display. However, moisture settings can be adjusted for a specific region with the displays Manual Moisture setting. The manual moisture setting will only be applied to the specified region.



# Harvest Interface Module

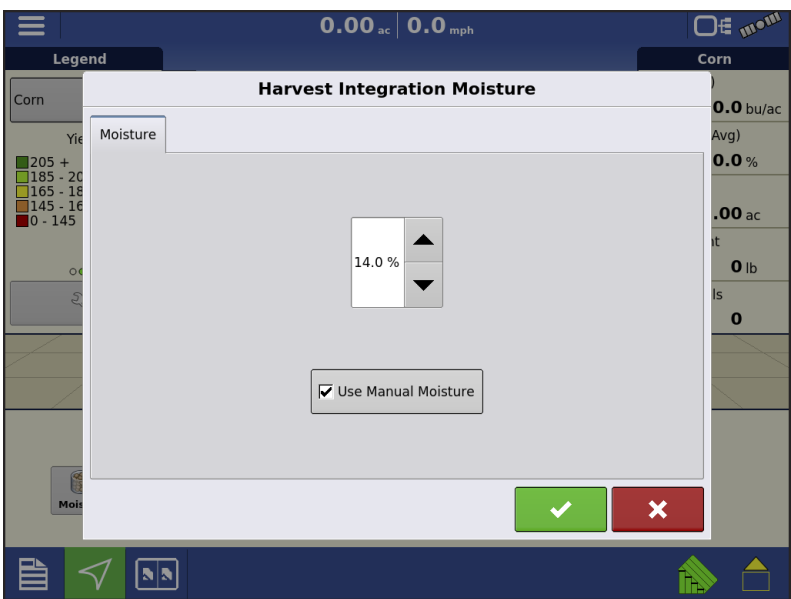

The Harvest Integration Moisture screen appears.

Check  Use Manual Moisture.

Use  /  to adjust the Manual Moisture to the desired value.

Press  when finished.

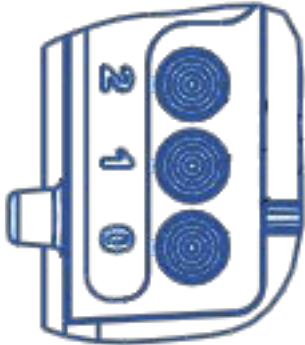

•LED Status

- OFF- CAN BUS Idle
- Solid Red – CAN BUS Off
- Solid Yellow – Passive BUS Error
- Blinking Yellow – Active BUS Error
- Blinking Green – CAN BUS Communicating

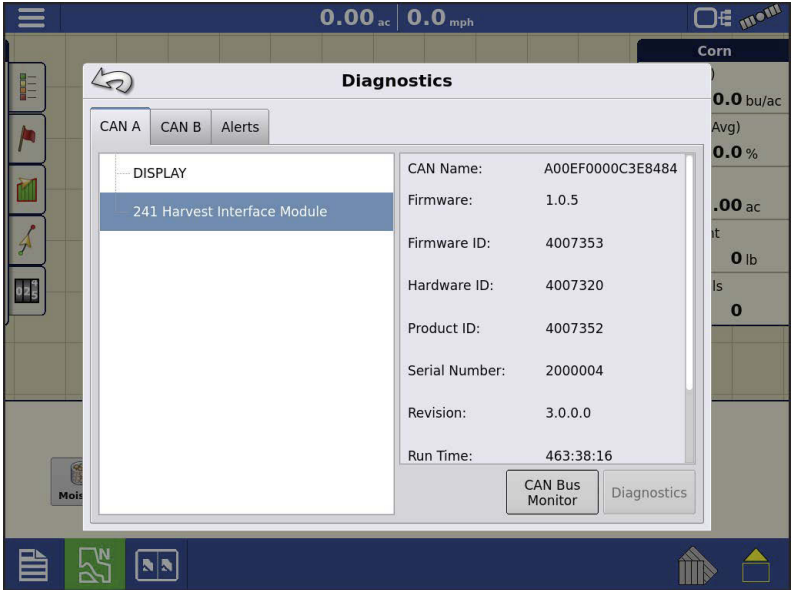

When the Harvest Interface Module is communicating with the display, it should appear on the display's Devices list



## Lexion Quantimeter

The Lexion Quantimeter Optical Sensing System includes the option of interfacing with the display. This option is available for LEXION harvesters of the 670 model and above. The display communicates with a Bridge Module. This Bridge Module receives data from the harvester via the CEBIS (CLAAS Electronic On-Board Information System) monitor which is then relayed to the display. The Bridge module can also interface with the ParaDyme, GeoSteer, or SteerCommand® Steering Systems.

## Map View

Once a configuration has been completed, and a field operation has been started, the Map View screen appears.

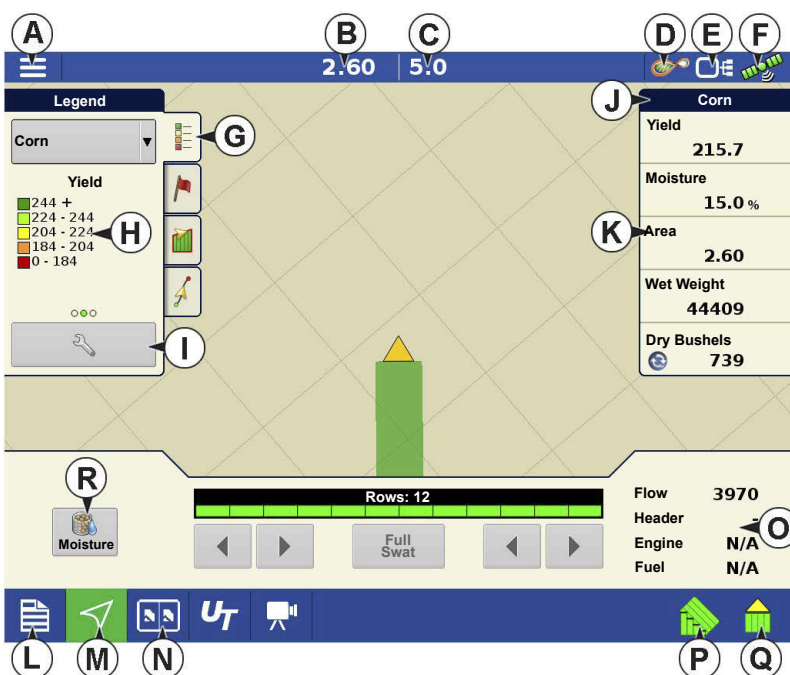

- A.Menu button
- B.Total Logged Field Area
- C.Ground Speed
- D.AgFiniti® Status Indicator
- E.Diagnostics Status Indicator
- F.GNSS Status Indicator
- G.Legend Tab
- H.Map Legend (varieties)
- I.Legend Select
- J.Crop
- K.Status Items

- L. Event Summary
- M. Map View button
- N. Split screen
- O. Harvest Diagnostics
- P. AutoSwath™
- Q. Logging Status

---

## R. Moisture Calibration

Pressing the Map View button (M) will cycle between the available Mapping screen views.

### (K) Harvest Status Items

<b>Corn</b>	
Hybrid 2	
Yield	208.5
Moisture	18.0 %
Area	1.79
Wet	26262
Dry	469

- **Yield** — Displays the instantaneous yield while there is grain flow and the average yield when grain flow is not present.
- **Moisture** — Displays the instantaneous moisture when there is grain flow and the average when there is no grain flow.
- **Area** — Shows the area harvested for the current region.
- **Wet Weight** — Shows the actual weight that has been harvested for the current region.
- **Wet Bushels** — Shows the actual bushels that have been harvested for the current region.
- **Dry Bushels** — Displays the actual number of bushels at the specified dry moisture percentage.
  - If the actual moisture is below the set dry moisture percentage and "Expand Bushels for All Grains Below Dry %" is not checked, it will show actual bushels.
  - If the actual moisture is below the set dry moisture percentage and "Expand Bushels for All Grains Below Dry %" is checked, it will display bushels as if the moisture of the grain is at the specified dry percentage.

The **Wet Bushels** and **Dry Bushels** Status Items do not appear if you are using metric system measurements.

### (O) Harvest Diagnostic Button on Map Screen

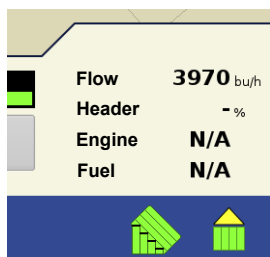

Flow	3970 <sup>bu/h</sup>
Header	- %
Engine	N/A
Fuel	N/A

The Harvest Diagnostic button appears at the bottom right-hand portion of the Harvest Map screen. Pressing this button summons the Harvest Diagnostic screen.

**Flow**—Displays current grain flow rate through the harvester.

**Header**—Displays current header height.

**Engine**—Display current engine speed (RPM).



**Fuel**—Displays instantaneous fuel consumption.



**NOTE!:** Elevator Speed information is not shown for Quantimeter configurations.

## Tracking Varieties and Changing Regions



Use the Options screen to enable the display to track varieties that were planted earlier and are now being harvested.

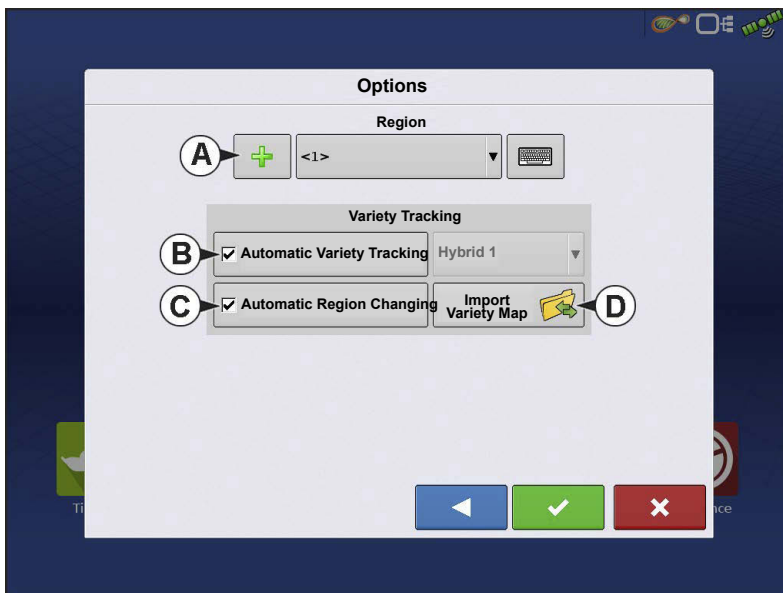

Types of variety tracking:

- Automatic Variety Tracking
- Automatic Region Changing.

The Options Screen is the last step before completing the harvest operational wizard. This can also be accessed from the Mapping screen by pressing the menu button followed by region.

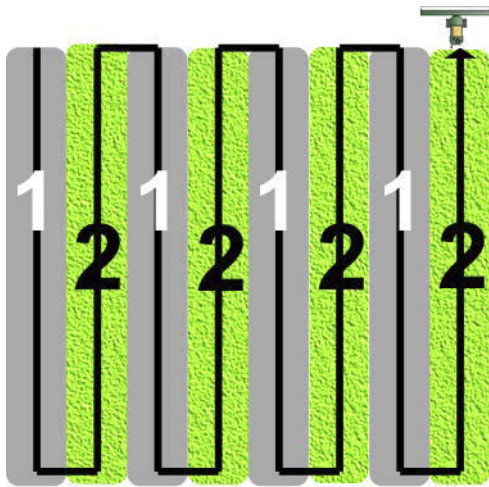

The illustration shows how the display could track two different varieties. In this example, when the harvester reaches the end of Variety 1, and moves to Variety 2, a message appears that either a new variety has been detected and the operator is notified to change regions (Automatic Variety Tracking,) or that a variety has been detected and the display is automatically changing regions. (Automatic Region Changing).

## (A) Region Selection

Press  to create new regions.

Use the drop-down to manually select or change regions.

## (B) Automatic Variety Tracking

Automatic Variety Tracking gives users the ability to track hybrids from planting/seeding operations during harvest. This gives quick access to yield information based on hybrids planted in the summary screen. Enable by checking the Automatic Variety Tracking box.

A variety map must be present to enable Automatic Variety Tracking.

If no variety map is present, then you can either

- (E) Manually assign a variety from the Variety Tracking List, located to the right of the Automatic Variety Tracking check box.

**OR**

- (D) Import a variety reference map.

---

## (C) Automatic Region Changing

If you wish to enable the Automatic Region Changing feature, select both the Automatic Variety Tracking check box, and the Automatic Region Changing check box. Automatic Region Changing will auto-sort varieties into regions as you go through the field.

- Automatic Region Changing tracks both varieties and regions, so the display changes the region automatically.

### In-Field Variety Tracking Messages



- With Automatic Variety Tracking selected, the message, “Variety detected. Go to the Region Selection screen to change Region and Variety” display’s each time the variety changes in the field. The message stays active until dismissed.
- With Automatic Region Changing selected a message noting the variety detected and region the display changed to appears each time the variety changes.

## (D) Importing Variety Maps

Variety maps can be imported from SMS™ software. The SMS software uses planting data to create a variety reference map which is saved as an .AGSETUP file. This .AGSETUP file can then be exported to the display for use with the Automatic Variety Tracking and Automatic Region Changing features.

### Importing Variety Map Procedure

#### Select Reference File

The File Selection screen appears. Use  /  to scroll through the files and select the desired reference (.AGSETUP) file. Press  when finished.

### Error Messages at Variety Map Import

If the display failed to import a variety map, it is likely that one of three error messages appears on the display:

**Error Message:** “Crop type of Variety Reference Map does not match crop type of field.”

**Possible Cause:** A different crop type was selected in the Harvest Operation Wizard than is shown in the variety reference map.

**Solution:** Either create a Harvest Operation with a different crop; or choose a variety reference map with an appropriate crop.

---

**Error Message:** “Variety Reference Map does not match location of field.”

**Possible Cause:** A different farm or field was selected in the Harvest Operation Wizard than is shown in the variety reference map.

**Solution:** Either create a Harvest Operation with a different field, or choose a variety reference map with an appropriate field.

**Error Message:** “Too many zones to show complete Variety Reference Map. Variety Tracking will work on all zones, even those not mapped on screen.”

**Possible Cause:** The reference file selected exceeded the allowable memory limit used to load reference maps.

**Solution:** Continue harvest operations. All variety tracking and region information will be logged. However, the entire reference map may not be visible on the display’s Mapping screen.

### **AutoSwath Sensitivity Settings**

AutoSwath adjusts the swath width when crossing field boundaries and already-harvested areas. The display changes the swath width being harvested, even though no mechanical change takes place. AutoSwath is useful when harvesting point rows or where harvesting a full head width is not possible. When performing a Harvest operation, the AutoSwath feature includes sensitivity levels, which compensate for varying levels of GPS accuracy. If swath adjustments are performing inaccurately, adjust the sensitivity accordingly. Sensitivity 3 is the default setting. This setting is adjusted from the Configuration Setup menu.

Other settings include:

**Sensitivity 5** — Use with RTK or DGPS (GPS6500 RTK or TerraStar with SteerCommand).

**Sensitivity 4** — Use with RTK or sub-meter DGPS. Terrain compensation recommended (GPS6000 or GPS6500 with Steering).

**Sensitivity 3** — Use with sub-meter accurate DGPS (most SBAS receivers like GPS6000).

**Sensitivity 2** — Use with 1+ meter accurate GPS.

**Sensitivity 1** — Swath sections are all on or all off. Use with 1+ meter accurate GPS.

## Map Options

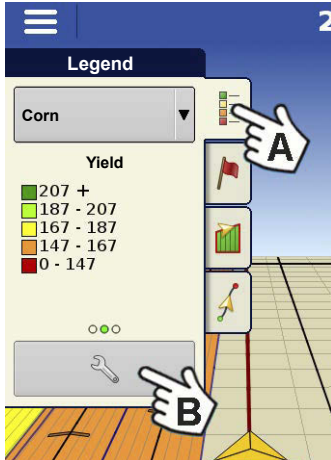

2 During Harvest operations, the Mapping screen displays three types of items in the Legend: Yield, Moisture, and Coverage.

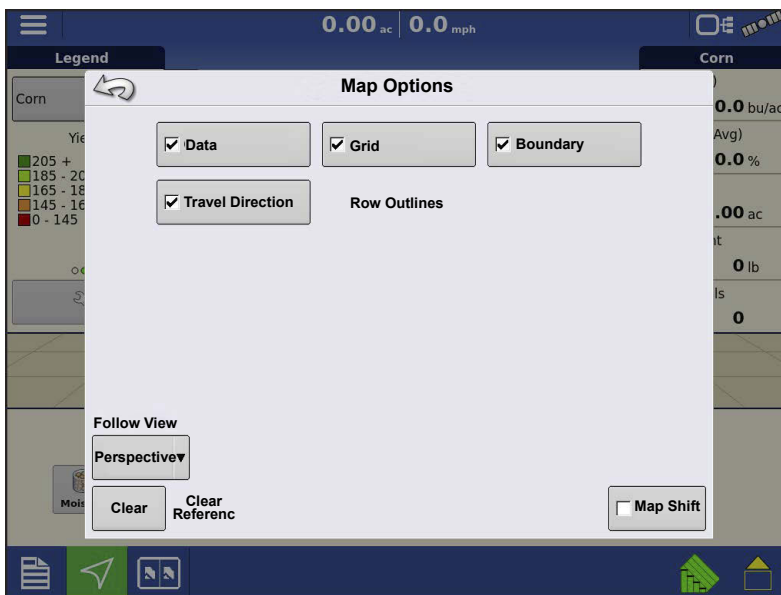

The Legend Setup button on the Map Legend Tab of the Mapping Toolbox opens the Map Options screen.

- Press Data, Guidance, Boundary, Marker, Reference, Grid, Travel Direction, and Row Outlines to show or hide those items on the Map screen.

- Press Clear Map to permanently remove all map data from the active field operation

- Press Load Reference to load a map from a previous operation performed in that field to view as a background map.

## Delay

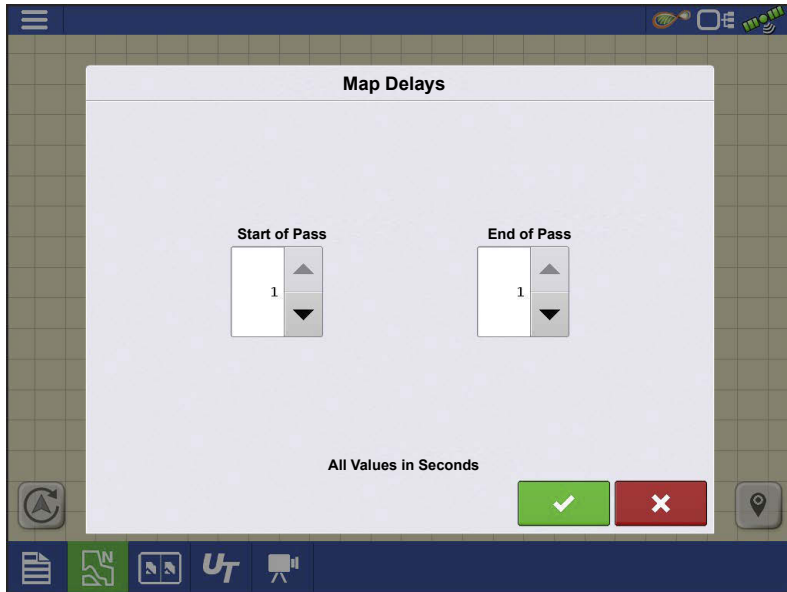

### •Start of Pass

The time between when the header is lowered and when the row starts. This compensates for a delay between when header is lowered and when it begins taking in the crop.

### •End of Pass

The time between when row ended and when the header is raised. This compensates for a delay between

when the header finishes taking in the crop and when the header is raised.

## Create Configuration

A wizard is used to guide through the process of selecting or creating a configuration that includes Harvester, Header and Crops settings.

The configuration can be started in two places:



Upon completion, the Configuration will then be viewable when starting a new Field Operation with the Harvest Operation Wizard.



**NOTE!:** When creating a configuration be sure to select “Quantimeter” as the harvest system type.

The **Manage Equipment** button can be used to create or edit specific vehicles and implements.

## Load Configuration



Press the Harvest app from the home screen. Follow field operation wizard prompts to load the configuration to the Mapping screen.

## Calibration Information

Most calibration information used in a Quantimeter configuration is calculated in the CEBIS monitor and then relayed to the display. For Quantimeter configurations, the CEBIS monitor performs calibrations for the Header Sensor, Yield Monitor, Moisture and Temperature.



**NOTE!:** The calibration created in the Quantimeter is a linear calibration.

When a new calibration is started in the CEBIS monitor, a warning appears on the display, stating “A new grain calibration has been detected. Select an operating configuration to continue.” At the same time, the display unloads the Field Operating Configuration that was collecting data with the old calibration. Acknowledge the New Grain Calibration warning by pressing .

After completing the grain weight calibration and the new calibration factor has been calculated in the CEBIS monitor, this new calibration is then sent to the display. The display then uses the new calibration to update all data collected since the time it detected the start of the new calibration. No further messages appear in the display.



**NOTE!:** The New Grain Calibration warning does not appear for the first calibration performed during the season. It only appears for calibrations performed thereafter.



**NOTE!:** The display does not update any previously-collected data collected prior to the time it detected the start of the new calibration.

## Manual Moisture Setting

As with other calibration information, the Moisture Calibration is calculated in the CEBIS monitor and then relayed to the display. However, moisture settings can be adjusted for a specific region with the displays Manual Moisture setting. The manual moisture setting will only be applied to the specified region.

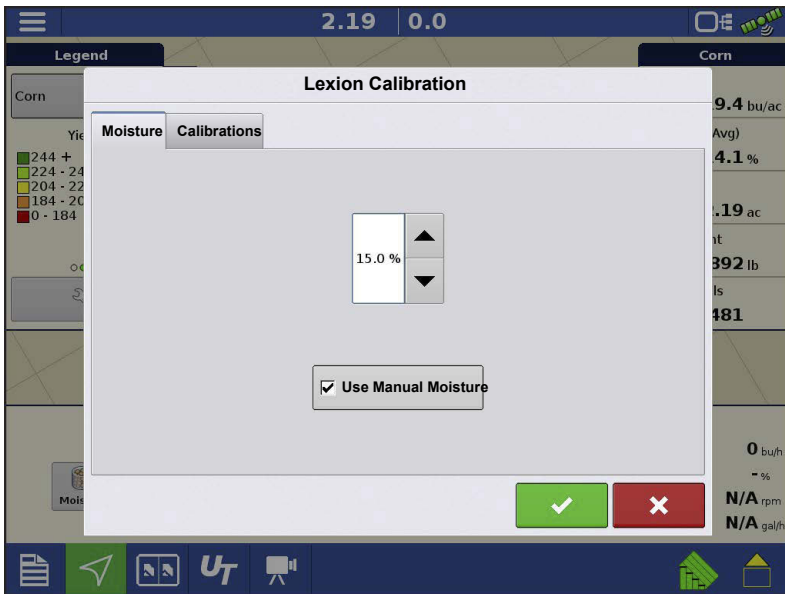

The Lexion Calibration screen appears.

Check  Use Manual Moisture.

Use  /  to adjust the Manual Moisture to the desired value.

Press  when finished.

 **NOTE!:** The list shown in the Lexion Calibration screen only shows loads harvested during the current

season.

## Diagnostics for Quantimeter

When performing a Harvest operation, access the Grain Harvest Diagnostics screen by pressing:



The Grain Harvest Diagnostic screen may help in diagnosing a problem. When the Devices screen opens, press and highlight the AL Bridge listing in the CAN Device list, then press the Diagnostics button. The Grain Harvest Diagnostics screen appears.





### NOTE!

The Grain Harvest Diagnostics screen displays different information than the Diagnostics screen that appears for other Harvest configurations. This information is relayed from the CEBIS monitor.

For specific information regarding settings shown on this screen, contact Technical Support.

## Bridge Module

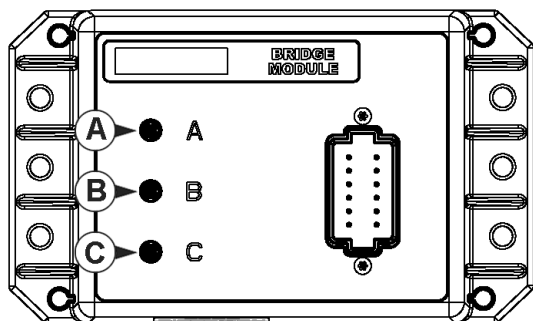

The Bridge Module routes communication between

A. CAN-Bus

B. Steering CAN-Bus

C. Claas CAN-Bus

Three indicator lights verify communication received from these systems. A green light indicates good communication; an amber light indicates no communication.



When the Bridge Module is communicating with the display, it should appear on the display's Devices list.

---

## Troubleshooting Quantimeter Configurations

During the operation of a Quantimeter field operation configuration, you may see the following error messages. Below is a table describing the cause and solution of the error messages that could appear.

**Error Message**—Warning: “Full header width doesn’t match Quantimeter full header width”

**Possible Cause**—The full header width that was specified in the display’s Header Setup Wizard does not match the header width in the CEBIS monitor.

Set the swath width in the CEBIS monitor to match the swath width of the operating configuration in the display.

**Error Message**—Crop Type Changed: “The current configuration is no longer valid”

**Possible Cause**—The display has detected that the crop type specified in the CEBIS monitor has changed to a crop type that is different than what is specified in the display’s field operation configuration.

Either:

**Solution 1**—Change the crop type specified in the CEBIS monitor back to what is specified in the display. Then reload the display’s field operation configuration.

Or

**Solution 2**—Create a new field operation configuration that includes the new crop type. If necessary, create a new Harvest Product in Product Setup with the Harvest Crop Wizard.

**Error Message**—Grain Calibration: “A new grain calibration has been detected. Select an operating configuration to continue.”

**Possible Cause**—When a new calibration is started in the CEBIS monitor, the warning at left appears on the display. At the same time, the display unloads the Field Operating Configuration that was collecting data with the old calibration.

**Solution**—Acknowledge the warning by pressing . At the Home screen, press the Select Event button. Use the Field Operation Wizard to create a new field operation configuration. After receiving the new calibration from the CEBIS monitor, the display will calculate that field operation configuration’s harvest data by using this new calibration that was sent from CEBIS.

**Error Message**—Lexion Communication Error: “Cannot communicate with Lexion bridge module.”

---

**Possible Cause**—No communication between Bridge Module and Lexion CAN-Bus.  
(Shown as Indicator Light C on Bridge Module).

**Solution**—Check cabling between Module and Lexion Can-Bus.

**Error Message**—CAN Node Lost: “AL Bridge Node has stopped communicating.”

**Possible Cause**—No communication between Bridge Module and display. (Shown as Indicator Light A on Bridge Module.)

**Solution**—Check cabling between Bridge Module and display.

---

## Jaguar Quantimeter

The Jaguar Quantimeter kit includes the needed hardware to allow the Ag Leader InCommand™ 1200 and 800 displays to read and record yield data from the machine. This option is available for the following 2009 model year and newer Jaguar Models:

Type 494 - 930, 940, 950, 960, 970, 980

Type 496 - 840, 850, 860, 880

Type 497 - 930, 940, 950, 960, 970, 980

Type 498 - 930, 940, 950, 960, 970, 980



**NOTE!** If you are unsure of your vehicle type, contact your CLAAS dealer.

The display communicates with a Bridge Module. The bridge module receives data from the harvester via the CEBIS (CLAAS Electronics On-Board Information System) monitor which is then sent

to the display. The Bridge Module is also used to interface SteerCommand® to the Jaguar's autosteer system.



**NOTE!** In order to interface into the steering system, the machine needs to be unlocked for 3rd party steering systems.

## Map View

Once a configuration has been completed, and a field operation has been started, the Map View screen appears.

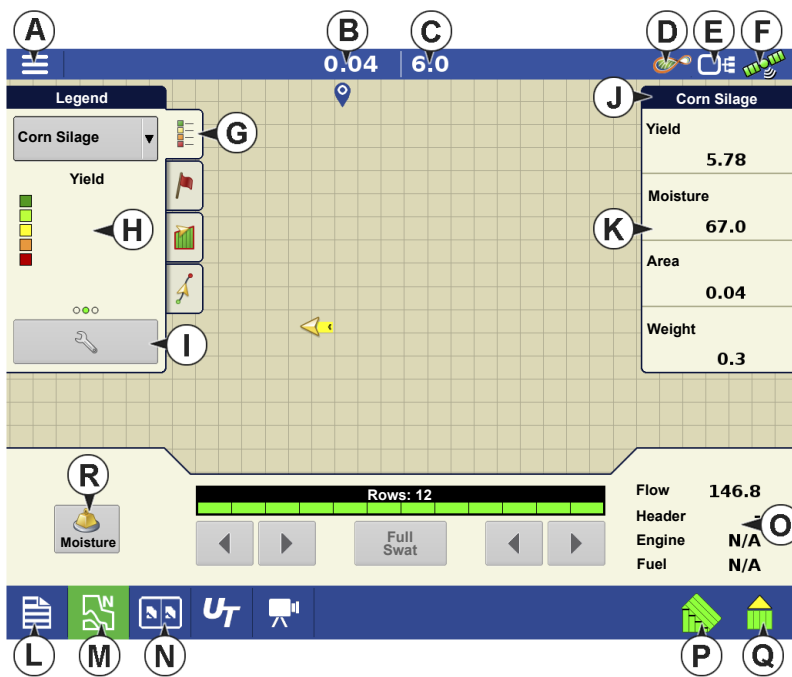

- A.Menu button
- B.Total Logged Field Area
- C.Ground Speed
- D.AgFiniti® Status Indicator
- E.Diagnostics Status Indicator
- F.GNSS Status Indicator
- G.Legend Tab
- H.Map (yield)
- I.Legend Select
- J.Crop
- K.Status Items

- L. Event Summary
- M. Map View button
- N. Split screen
- O. Harvest Diagnostics
- P. AutoSwath™
- Q. Logging Status
- R. Moisture Calibration

Pressing the Map View button (M) will cycle between the available mapping screen views.

### (K) Harvest Status Items

Corn	
Yield	5.78
Moisture	67.0
Area	0.04
Weight	0.3

- Yield** — Displays the instantaneous yield while there is mass flow and the average yield when flow is not present.
- Moisture** — Displays the instantaneous moisture when there is mass flow and the average when there is no flow.
- Area** — Shows the area harvested for the current region.
- Weight** — Shows actual weight that has been harvested for the current region.

## (O) Harvest Diagnostic Button on Map Screen

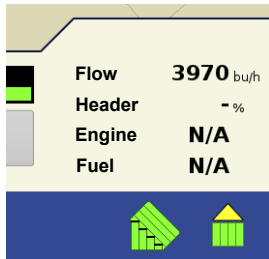

The Harvest Diagnostic button appears at the bottom right-hand portion of the Harvest Map screen. Pressing this button summons the Harvest Diagnostic screen.

**Flow**—Displays current mass flow rate through the harvester.

**Header**—Displays current header height.

**Engine**—Display current engine speed (RPM).

**Fuel**—Displays instantaneous fuel consumption.



**NOTE!**: Elevator Speed information is not shown for Quantimeter configurations.

## Changing Regions

You can use the options screen to create regions to track yield in different areas of the field.



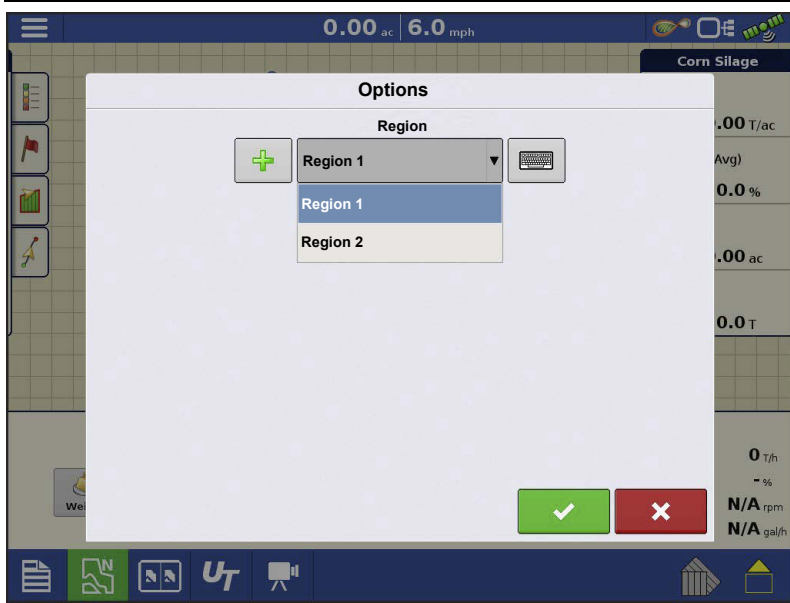



## AutoSwath Sensitivity Settings

AutoSwath adjusts the swath width when crossing field boundaries and already-harvested areas. The display changes the swath width being harvested, even though no mechanical change takes place. AutoSwath is useful when harvesting point rows or where harvesting a full head width is not possible. When performing a Harvest operation, the AutoSwath feature includes sensitivity levels, which compensate for varying levels of GPS accuracy. If swath adjustments are performing inaccurately, adjust the sensitivity accordingly. Sensitivity 3 is the default setting. This setting is adjusted from the Configuration Setup menu.

Other settings include:

**Sensitivity 5** — Use with RTK or DGPS (GPS6500 RTK or TerraStar with SteerCommand).

**Sensitivity 4** — Use with RTK or sub-meter DGPS. Terrain compensation recommended (GPS6000 or GPS6500 with Steering).

**Sensitivity 3** — Use with sub-meter accurate DGPS (most SBAS receivers like GPS6000).

**Sensitivity 2** — Use with 1+ meter accurate GPS.

**Sensitivity 1** — Swath sections are all on or all off. Use with 1+ meter accurate GPS.

## Map Options

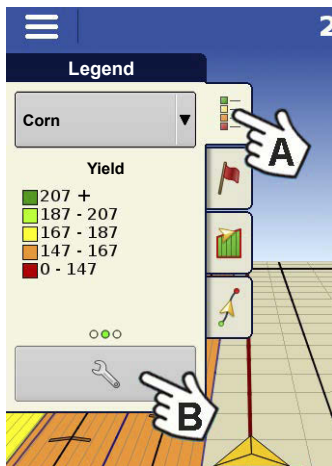

### 2 Region Selection

- Press + button to create new regions.
- Use the drop-down to manually select or change regions.

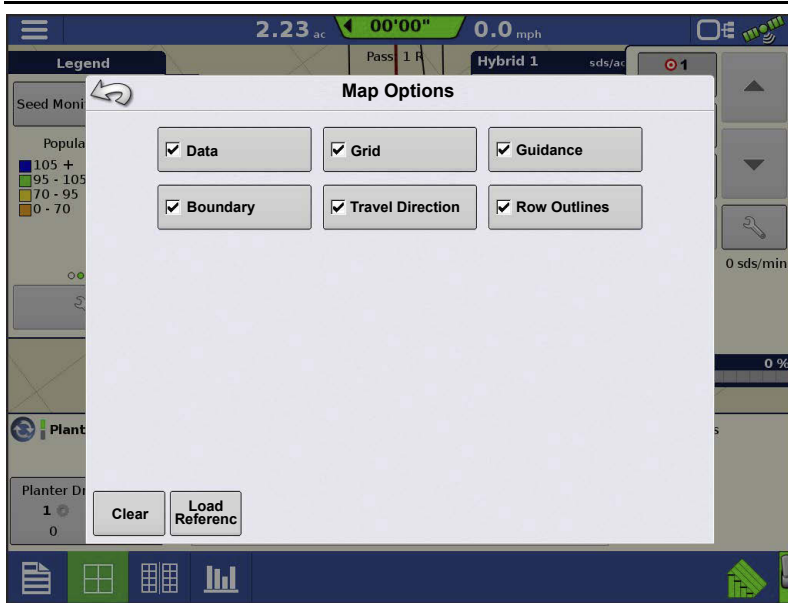

A. During Harvest operations, the Map screen displays three types of items in the Legend: Yield, Moisture, and Coverage.

B. The Legend Setup button on the Map Legend Tab of the Mapping Toolbox opens the Map Options screen.

• Press Data, Guidance, Boundary, Marker, Reference, Rx and Grid to show or hide those items on the Map

screen.

- Press Clear Map to permanently remove all map data from the active field operation
- Press Load Reference to load a map from a previous operation performed in that field to view as a background map.

## Create Configuration

A wizard will guide you through the process of selecting or creating a configuration that includes Harvester, Header and Crops settings.

The configuration can be started in two places:



Your Operating Configuration will then be viewable when you start a new Field Operation with the Harvest Operation Wizard.

- Use swath width for a platform
- Use number of rows and row spacing for header

You can also use the **Manage Equipment** button to create or edit specific vehicles and implements.

## Load Configuration



Press the harvest operations button from the home screen. This will take you through the steps needed to load a configuration.

## Calibration Information

Most calibration information used in a Quantimeter configuration is calculated in the CEBIS monitor and then relayed to the display. For Quantimeter configurations, the CEBIS monitor performs calibrations for the Header Sensor, Yield Monitor, Moisture and Temperature.



**NOTE!:** The calibration created in the Quantimeter is a linear calibration.

When a new calibration is started in the CEBIS monitor, a warning appears on the display, stating “A new calibration has been detected. Select an operating configuration to continue.” At the same time, the display unloads the Field Operating Configuration that was collecting data with the old calibration. Acknowledge the New Calibration warning by pressing .

After you have completed the weight calibration and a new calibration factor has been calculated in the CEBIS monitor, this new calibration is then sent to the display. The display then uses the new calibration to update all data collected since the time it detected the start of the new calibration. No further messages appear in the display.



**NOTE!:** The New Calibration warning does not appear for the first calibration performed during the season. It only appears for calibrations performed thereafter.



**NOTE!:** The display does not update any previously-collected data collected prior to the time it detected the start of the new calibration.

## Diagnostics for Quantimeter

When performing a Harvest operation, you can access the Harvest Diagnostics screen by

pressing  . Technical support may request that you look at this

screen for help in diagnosing a problem. When the Devices screen opens, press and highlight the AL Bridge listing in the CAN Device list, then press the Diagnostics button. The Harvest Diagnostics screen appears.



**NOTE!:** The Harvest

Diagnostics screen displays different information than the Diagnostics screen that appears for other Harvest configurations. This information is relayed from the CEBIS monitor.

For specific information regarding settings shown on this screen, contact Technical Support.

## Bridge Module

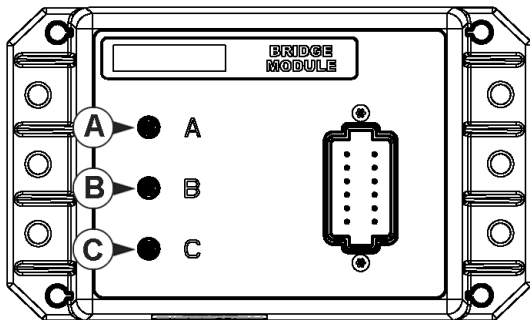

The Bridge Module routes communication between

- A. CAN-Bus
- B. Steering CAN-Bus
- C. CLAAS CAN-Bus

Three indicator lights verify communication received from these systems. A green light indicates good communication; an amber light indicates no communication.



When the Bridge Module is communicating with the display, it should appear on the display's Devices list.

## Troubleshooting Quantimeter Configurations

During the operation of a Quantimeter field operation configuration, you may see the following error messages. Below is a table describing the cause and solution of the error messages that could appear.

**Error Message**—Warning: “Full header width doesn’t match Quantimeter full header width”

**Possible Cause**—The full header width that was specified in the display’s Header Setup Wizard does not match the header width in the CEBIS monitor.

Set the swath width in the CEBIS monitor to match the swath width of the operating configuration in the display.

**Error Message**—Crop Type Changed: “The current configuration is no longer valid”

**Possible Cause**—The display has detected that the crop type specified in the CEBIS monitor has changed to a crop type that is different than what is specified in the display’s field operation configuration.

Either:

**Solution 1**—Change the crop type specified in the CEBIS monitor back to what is specified in the display. Then reload the display’s field operation configuration.

---

Or

**Solution 2**—Create a new field operation configuration that includes the new crop type. If necessary, create a new Harvest Product in Product Setup with the Harvest Crop Wizard.

**Error Message**—Calibration: “A new forage calibration has been detected. Select an operating configuration to continue.”

**Possible Cause**—When a new calibration is started in the CEBIS monitor, the warning at left appears on the display. At the same time, the display unloads the Field Operating Configuration that was collecting data with the old calibration.

**Solution**—Acknowledge the warning by pressing . At the Home screen, press the Select Event button. Use the Field Operation Wizard to create a new field operation configuration. After receiving the new calibration from the CEBIS monitor, the display will calculate that field operation configuration’s harvest data by using this new calibration that was sent from CEBIS.

**Error Message**—CLAAS Communication Error: “Cannot communicate with CLAAS bridge module.”

**Possible Cause**—No communication between Bridge Module and CLAAS CAN-Bus. (Shown as Indicator Light C on Bridge Module).

**Solution**—Check cabling between Module and CLAAS Can-Bus.

**Error Message**—CAN Node Lost: “AL Bridge Node has stopped communicating.”

**Possible Cause**—No communication between Bridge Module and display. (Shown as Indicator Light A on Bridge Module.)

**Solution**—Check cabling between Bridge Module and display.