

# MODEL 5700 FRONT FOLDING PLANTER OPERATOR'S MANUAL

**M0320-01**

**Rev. 8/24**

This manual is applicable to: Model 5700 Forward Folding Planters

Record the model number and serial number of your planter along with date purchased:

Model Number 5700

Serial Number \_\_\_\_\_

Date Purchased \_\_\_\_\_

Monitor Serial Number _____
Measured Pulses Per km (Radar Distance Sensor) _____
Measured Pulses Per km (Magnetic Distance Sensor) _____

## SERIAL NUMBER

The serial number plate is located on the planter frame as shown below. The serial number provides important information about your planter and is needed to obtain correct replacement parts. Always provide model number and serial number to your Kinze Dealer when ordering parts or when contacting Kinze Manufacturing, Inc.



**Serial Number Plate Location**

**This page intentionally left blank.**

**TO THE DEALER**

Predelivery service includes assembly, lubrication, adjustment and test. This service helps ensure planter is delivered to retail customer/end user ready for field use.

**PREDELIVERY CHECKLIST**

Use the following checklist after planter is completely assembled. Check off each item as it is found satisfactory or after proper adjustment is made.

- Row units properly spaced and optional attachments correctly assembled.
- Row unit hopper lid assemblies are proper aligned in hopper supports.
- Row marker assemblies installed and adjusted at each end of the planter.
- Vacuum meter and bulk fill components properly installed (as applicable).
- All grease fittings in place and lubricated.
- All working parts move freely, bolts are tight, and cotter pins are spread.
- Check all drive chains for proper tension and alignment.
- Check for oil leaks and proper hydraulic operation.
- Hydraulic hoses correctly routed to prevent damage.
- Inflate tires to specified air pressure and torque wheel lug bolts and lug nuts as specified in the Operator Manual.
- All safety decals correctly located and legible. Replace if damaged.
- All reflective decals and SMV sign correctly located and visible when the planter is in transport position.
- Safety/warning lights correctly installed and working properly.
- Paint all parts scratched during shipment or assembly.
- All safety lockup devices on the planter and correctly located.
- Auxiliary safety chain properly installed and hardware torqued to specification.
- Vacuum fan PTO-driven pump correctly attached to tractor. Oil reservoir filled to capacity and system inspected for leaks (If applicable).
- Bulkfill hoses remain in place with no belt slipping or hose pinching between stub wing and vacuum manifold.

***Planter has been thoroughly checked and to the best of my knowledge is ready for delivery to the customer.***

\_\_\_\_\_  
(Signature of Set-Up Person/Dealer Name/Date)

**OWNER REGISTER**

Name \_\_\_\_\_ Delivery Date \_\_\_\_\_

Street Address \_\_\_\_\_ Model No. 5700 Serial No. \_\_\_\_\_

City, State/Province \_\_\_\_\_ Dealer Name \_\_\_\_\_

ZIP/Postal Code \_\_\_\_\_ Dealer No. \_\_\_\_\_

---

## DELIVERY CHECKLIST

Use the following checklist at time planter is delivered as a reminder of very important information which should be conveyed to retail customer/end user. Check off each item as it is fully explained.

- Check proper operation of vacuum fan, bulk fill fan, and PTO-driven pump (If applicable) with tractor used with planter.
- Life expectancy of this or any other machine is dependent on regular lubrication as directed in the Operator Manual.
- All applicable safety precautions.
- Along with retail customer/end user, check reflective decals and SMV sign are clearly visible with planter in transport position and attached to tractor. Check safety/warning lights are in working condition. Tell retail customer/end user to check federal, state/provincial, and local regulations before towing or transporting on a road or highway.
- Give Operator Manual, Parts Manual, and all Instruction Sheets to retail customer/end user and explain all operating adjustments.
- Read warranty to retail customer/end user.
- Complete Warranty and Delivery Report form.

***To the best of my knowledge this machine has been delivered ready for field use and customer has been fully informed as to proper care and operation.***

---

(Signature of Delivery Person/Dealer Name/Date)

## AFTER DELIVERY CHECKLIST

The following is a list of items we suggest to check during the first season of use of the equipment.

- Check planter performance with retail customer/end user.
- Check performance of vacuum meter or mechanical seed metering system with retail customer/end user.
- Review importance of proper maintenance and adherence to all safety precautions with retail customer/end user.
- Check for parts that may need to be adjusted or replaced.
- Check all safety decals, reflective decals, and SMV sign are correctly located as shown in the Parts Manual and that decals are legible. Replace if damaged or missing.
- Check safety/warning lights are working properly.

---

(Signature of Follow-Up Person/Dealer Name/Date)

**All registrations must be submitted online at "[business.kinze.com](http://business.kinze.com)" within 5 business days of delivery.  
Retain a copy of this form for auditing purposes.**

*Tear Along Perforation*

**KINZE**

**OVERVIEW**

To The Owner .....	1-1
Warranty .....	1-3
General Information .....	1-3
Specifications .....	1-5
General Safety Rules .....	1-6
Safety Precautions .....	1-7
Safety Precautions .....	1-8

**MACHINE OPERATION**

Row Marker Safety Lockup .....	2-1
Transport Axle Cylinder Safety Lockup .....	2-2
Drawbar Hitch Lockup .....	2-3
Wing Latch Lockup .....	2-4
Initial Planter Preparation .....	2-4
Tractor Requirements .....	2-6
Bulk fill Tractor Mounted PTO Pump and Planter Mounted Hydraulics .....	2-7
Tractor Preparation and Hookup .....	2-8
True Depth Hydraulic System Overview .....	2-11
True Depth Filter .....	2-12
Transporting Planter .....	2-13
Level Planter .....	2-14
Jump Start Sensor .....	2-15
Field Operation .....	2-15
Unfold .....	2-16
Fold .....	2-17
Row Marker Operation using Blue Vantage Display .....	2-18
Row Marker Speed Adjustment .....	2-19
Row Marker Cable Adjustment .....	2-20
Row Marker Length And Disc Blade Adjustment .....	2-21
Vacuum Meter System .....	2-22
Analog Vacuum or Pressure Gauge .....	2-22
Bulk Fill System .....	2-23
Bulk fill Entrainer Access .....	2-24
Bulk Fill Tanks - Clean Out .....	2-25
Bulk Fill Scale Package Option .....	2-26
Kinze Blue Vantage .....	2-30
Field Test .....	2-31
Field Check Seed Population .....	2-32
Determining Pounds Per Acre .....	2-33
Determining Bushels Per Acre .....	2-33
Field Check Granular Chemical Application .....	2-34
Yetter 2940 Air Adjust Residue Manager .....	2-35

**ROW UNIT OPERATION**

Planting Depth .....	3-1
Closing Wheel General Adjustments .....	3-1
Air Adjust Closing Wheel Arm (PCW) .....	3-2
PDP and Air Closing Wheel Schematics .....	3-3
Row Unit Mounted No Till Coulter .....	3-4
Coulter Mounted Residue Wheels W/Treader .....	3-4
Pneumatic Down Pressure (PDP) .....	3-5
Field Operation .....	3-6
True Depth .....	3-7
Seed Hoppers .....	3-8
Manual Run Button (Blue Drive) .....	3-8
True Rate Settings .....	3-9
Wheat Disc Wiper Installation .....	3-13
True Speed Meter Settings .....	3-14
True SPeed Vacuum Settings Charts .....	3-16
True Speed Seed Meter Cover Removal .....	3-26
Granular Chemical .....	3-30
Row Unit Mounted No Till Coulter .....	3-31
Coulter Mounted Residue Wheels .....	3-32

**FERTILIZER**

System Overview .....	4-1
Liquid Fertilizer Attachment .....	4-1
Pulsation Damper (Diaphragm Pump) - Model Number AR160 only .....	4-10
Fertilizer Tank .....	4-11
Row Flow meter .....	4-14
Row Flow Meter Cleanout .....	4-15
Row Flow meter Jet Orifice Removal .....	4-16
Row Flow meter Jet Orifice Installation .....	4-18
Flow meter Strainer and Orifice Cleaning and/or Replacement .....	4-20
Orifice Configuration Rates .....	4-22
Pump Clean Out and Storage .....	4-24
In Furrow .....	4-26
Auxiliary Plumbing for Liquid Fertilizer .....	4-27
Fertilizer Pump Troubleshooting .....	4-29
Fertilizer System Troubleshooting .....	4-30

**LUBRICATION AND MAINTENANCE**

Lubrication .....	5-1
Lubrication Symbols .....	5-1
Wheel Bearings .....	5-1
Bushings .....	5-2
Grease Fittings .....	5-3
PTO Shaft Coupling .....	5-7

Mounting Bolts and Hardware . . . . .	5-8	PTO Draft Link harness - 24 Row 30" and 36 Row 20" (P/N: 10803501); 24 Row 20" (P/N 10803502) . . . . .	5-48
Tire Pressure . . . . .	5-10	Camera Power Harness (P/N: 10269201) . . . . .	5-49
Transport Tires . . . . .	5-10	PDP Control/Sensor Harness (P/N: 10820101/10820102) . . . . .	5-50
Inflation Specifications . . . . .	5-11	CAN Stub Harness (P/N: 10286101/10286102) . . . . .	5-50
True Rate Meter Maintenance . . . . .	5-12	Bulk Fill Scale CAN Cable PHD28 Harness (P/N: 10242801) . . . . .	5-51
True Rate Seed Meter Cleanout . . . . .	5-12	Integrated True Depth Row Unit Harness (P/N: 10803401) . . . . .	5-52
Vacuum Manifold Maintenance . . . . .	5-13	Yetter Row Cleaner Compressor Harness (P/N:10558202) . . . . .	5-53
True Speed Seed Meter Maintenance . . . . .	5-14	Yetter Row Cleaner PWR/CAN Harness (P/N:10631701) . . . . .	5-54
True Speed Seed Meter Cleanout . . . . .	5-15	True Speed PULL Row Unit W/IPP Harness (P/N: 10916001) . . . . .	5-55
True Speed Delivery Tube Maintenance . . . . .	5-16	True Rate PULL Row Unit W/IPP Harness (P/N: 10915901) . . . . .	5-56
True Speed Maintenance Chart . . . . .	5-19	True Speed Pull Row Unit Harness (P/N:10915801) . . . . .	5-57
Gauge Wheel Adjustment . . . . .	5-21	True Rate Pull Row Unit Harness (P/N:10915701) . . . . .	5-58
Gauge Wheel Arm Pivot Spindle Replacement . . . . .	5-22	Taillight Extension Harness (P/N: A25207) . . . . .	5-59
Gauge Wheel Arm Bushing/Seal . . . . .	5-23	Tractor Console Harness - 12 Row, 16 Row, and 24 Row (P/N: A25031) . . . . .	5-59
15" Seed Opener Disc Blade/Bearing Assembly . . . . .	5-24	Work Light harness (P/N: A22547) . . . . .	5-60
Seed Tube Guard/Inner Scraper . . . . .	5-25	Insecticide harness (P/N: A22522) . . . . .	5-60
Row Unit Mounted No Till Coulter . . . . .	5-26	Work Light Harness (P/N: A26346) . . . . .	5-61
Coulter or Row Unit Mounted Residue Wheels W/Treader . . . . .	5-26	Row Unit Power Harness, 24 Row 30" - Rows 1-10 (P/N: 10136601) . . . . .	5-62
Spiked Closing Wheel . . . . .	5-26	Row Unit Power Harness, 24 Row 30" - Rows 14-24 (P/N: 10136701) . . . . .	5-63
Yetter 2940 Air Adjust Residue Manager Maintenance . . . . .	5-27	24V Power Harness - 24 Row 30" (P/N: 10136801) . . . . .	5-64
Tractor Mounted Pump Drive and Oil Cooler . . . . .	5-31	Row Unit Power Harness, 24 Row 20" - Rows 1-12 (P/N: A26572) . . . . .	5-65
Check Valve . . . . .	5-32	Row Unit Power Harness, 24 Row 20" - Rows 13-24 (P/N: A26571) . . . . .	5-66
Flow Control Valves . . . . .	5-32	Row Unit Power Harness, 36 Row - Rows 1-13, 17, and 18 (P/N: 10132001) . . . . .	5-67
Pressure Relief Valves . . . . .	5-32	Row Unit Power Harness, 36 Row - Rows 19, 20, and 24-36 (P/N: 10132201) . . . . .	5-68
Pressure Compensated Flow Control Valves . . . . .	5-32	24V Power Harness - 24 Row (P/N: 10136901) . . . . .	5-69
Solenoid Valve . . . . .	5-33	24V Power Harness (P/N: 10132101) . . . . .	5-70
Pneumatic Down Pressure Air Compressor Tank . . . . .	5-33	24V Power Harness (P/N: 10132301) . . . . .	5-71
Row Marker Break Away . . . . .	5-34	Draft Link Power Harness (P/N: 10210601) . . . . .	5-72
Row Marker Bearing Lubrication or Replacement . . . . .	5-35	L.H. Tail Light Harness (P/N: 10133001) . . . . .	5-73
Transport and Lift/Ground Drive Wheel Bearing Repack or Replacement . . . . .	5-36	R.H. Tail Light Harness (P/N: 10132901) . . . . .	5-73
Battery Care . . . . .	5-37	Tail Light Harness (P/N: A26379) . . . . .	5-74
Preparation for Storage . . . . .	5-38	Tail Light Harness (P/N: 10132801) . . . . .	5-75
Fertilizer IPN Harness (P/N: 10765601) . . . . .	5-39	Drawbar Hitch Harness (P/N: A26341) . . . . .	5-76
Ethernet Cables . . . . .	5-40	Fertilizer IPN Harness (P/N: 10765602) . . . . .	5-77
PTO Reverser Harness (P/N: 10263101) . . . . .	5-41	Fertilizer IPN Harness (P/N: 10210602) . . . . .	5-78
PTO Harness (P/N: 10200301) . . . . .	5-42	Air CLOSING Wheel Harness (P/N: 10806201) . . . . .	5-79
Tractor Power Harness - 12 Row, 16 Row, and 24 Row (P/N: 10211901) . . . . .	5-43		
Tractor Power 10' Extension Harness - 12 Row, 16 Row, and 24 Row . . . . .	5-43		
Fertilizer Module Harness (P/N:10741001) . . . . .	5-44		
Fertilizer Row Unit Extension Harness (P/N:10840301/10840302/10840303/10840304) . . . . .	5-45		
PTO System 12V Power Harness (P/N: 10292601) . . . . .	5-45		
12V Bus Box Harness (P/N: 10291901) . . . . .	5-46		
12V Air Pump Harness (P/N: 10188101) . . . . .	5-47		

Fold IPN Harness (P/N: 10741101 / 10741102) . . . . .	5-80
12V Power Harness (P/N: 10740901 / 10740902) . . . . .	5-82
Bulk Fill IPN Harness (P/N: 10806401) . . . . .	5-83
Right Wing IPN Harness (P/N: 10803201 / 10803202) . . . . .	5-84
Left Wing IPN Harness (P/N: 10803301/ 10803302) . . . . .	5-85
Bulk Fill Shutoff Intercept Harness (P/N: 10963101) . . . . .	5-86
Tail Light Extension Harness (P/N: A26631) . . . . .	5-87
Tail Light Harness (P/N: A27151) . . . . .	5-87
Row Unit Power Harness, 24 Row 20"- Rows 1-12 (P/N: A26572) . . . . .	5-88
Row Unit Power Harness, 24 Row 20"- Rows 13-24 (P/N: A26571) . . . . .	5-89
Drawbar Hitch Harness, 24 Row 20" (P/N: A26628) . . . . .	5-90
Drawbar Hitch Harness, 24 Row 20" (P/N: A26628) . . . . .	5-91
Hydraulic Hose Life . . . . .	5-92

## TROUBLESHOOTING

Bulk Fill . . . . .	6-1
Air Closing WHeels . . . . .	6-1
Row Marker Operation . . . . .	6-2
True Rate Seed Meter . . . . .	6-3
Solenoid Valve . . . . .	6-5
PTO Pump Drive and Oil Cooler Option . . . . .	6-5

**This page intentionally left blank.**





Kinze Manufacturing, Inc. thanks you for your patronage. We appreciate your confidence in Kinze farm machinery. Your Kinze planter has been carefully designed to provide dependable operation in return for your investment.

**This manual has been prepared to aid you in the operation and maintenance of the planter. It should be considered a permanent part of the machine and remain with the machine when you sell it.**

It is the responsibility of the user to read and understand the Operator Manual in regards to safety, operation, lubrication and maintenance before operation of this equipment. It is the user's responsibility to inspect and service the machine routinely as directed in the Operator Manual. We have attempted to cover all areas of safety, operation, lubrication and maintenance; however, there may be times when special care must be taken to fit your conditions.

Throughout this manual the symbol  and the words **DANGER**, **WARNING**, and **CAUTION** are used to call attention to safety information that if not followed, will or could result in death or injury. **NOTICE** and **NOTE** are used to call your attention to important information. The definition of each of these terms follows:

 <b>DANGER</b>	<p>Indicates an imminently hazardous situation that, if not avoided, will result in death or serious injury. This signal word is to be limited to the most extreme situations, typically for machine components which, for functional purposes, cannot be guarded.</p>
 <b>WARNING</b>	<p>Indicates a potentially hazardous situation that, if not avoided, could result in death or serious injury, and includes hazards that are exposed when guards are removed. It may also be used to alert against unsafe practices.</p>
 <b>CAUTION</b>	<p>Indicates a potentially hazardous situation that, if not avoided, may result in minor or moderate injury. It may also be used to alert against unsafe practices.</p>
<b>NOTICE</b>	<p>Used to address safety practices not related to personal injury.</p>

**NOTE:** Special point of information or machine adjustment instructions.

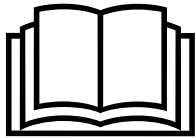
**WARNING**

Improperly operating or working on this equipment could result in death or serious injury. Read and follow all instructions in Operator's Manual before operating or working on this equipment.

**WARNING**

Some photos in this manual may show safety covers, shields, or lockup devices removed for visual clarity. **NEVER OPERATE OR WORK ON** machine without all safety covers, shields, and lockup device in place as required.

**NOTE:** Some photos in this manual may have been taken of prototype machines. Production machines may vary in appearance.

**NOTE:** Some photos and illustrations in this manual show optional attachments installed. Contact your Kinze Dealer for purchase of optional attachments.

## WARRANTY

The Kinze Limited Warranty for your new machine is stated on the retail purchaser's copy of the Warranty And Delivery Receipt form. Additional copies of the Limited Warranty can be obtained through your Kinze Dealer.

Warranty, within the warranty period, is provided as part of Kinze's support program for registered Kinze products which have been operated and maintained as described in this manual. Evidence of equipment abuse or modification beyond original factory specifications will void the warranty. Normal maintenance, service and repair is not covered by Kinze warranty.

To register your Kinze product for warranty, a Warranty And Delivery Receipt form must be completed by the Kinze Dealer and signed by the retail purchaser, with copies to the Dealer, and to the retail purchaser. Registration must be completed and submitted to Kinze Manufacturing, Inc. within 5 business days of delivery of the Kinze product to the retail purchaser. Kinze Manufacturing, Inc. reserves the right to refuse warranty on serial numbered products which have not been properly registered.

If service or replacement of failed parts which are covered by the Limited Warranty are required, it is the user's responsibility to deliver the machine along with the retail purchaser's copy of the Warranty And Delivery Receipt to the Kinze Dealer for service. Kinze warranty does not include cost of travel time, mileage or hauling. Any prior arrangement made between the Dealer and the retail purchaser in which the Dealer agrees to absorb all or part of this expense should be considered a courtesy to the retail purchaser.

*Kinze warranty does not include cost of travel time, mileage, hauling, or labor.*

## GENERAL INFORMATION

The Model 5700 Front Folding Planter is available with vacuum metering, bulk fill hopper, liquid fertilizer, and various other options. Contact your Kinze Dealer for additional details.



**Model 5700 24 Row Bulk Fill Planter with Liquid Fertilizer**

Information used in these instructions was current at time of printing. However, due to Kinze's ongoing product improvement, production changes may cause your machine to appear slightly different in detail. Kinze Manufacturing, Inc. reserves the right to change specifications or design without notice and without incurring obligation to install the same on machines previously manufactured. To obtain the most recent version of your publication, please contact your Kinze dealer.

Right hand (R.H.) and left hand (L.H.), as used throughout this manual, are determined by facing direction machine travels in use unless otherwise stated.

**NOTE: Metric unit values in parentheses are approximate values and are to be used for reference only.**

## TOOLS REQUIRED

Hardware Size / Tool Required			
$\frac{1}{4}" = \frac{7}{16}"$	$\frac{7}{16}" = \frac{5}{8}"$ (nut for $\frac{7}{16}"$ hardware uses $\frac{11}{16}"$ tool)	$\frac{3}{4}" = 1\frac{1}{8}"$	$1\frac{1}{4}" = 1\frac{7}{8}"$
$\frac{5}{16}" = \frac{1}{2}"$	$\frac{1}{2}" = \frac{3}{4}"$	$\frac{7}{8}" = 1\frac{5}{16}"$	$1\frac{1}{2}" = 2\frac{1}{4}"$
$\frac{3}{8}" = \frac{9}{16}"$	$\frac{5}{8}" = 1\frac{5}{16}"$	$1" = 1\frac{1}{2}"$	

**Model Dimension and Weights**







Specification	36 Row 20"	24 Row 30"	24 Row 20"
<b>Length</b>			
Planting - Bulk Fill Hoppers	30' 1"	30' 1"	25' 4"
Transport - Bulk Fill Hoppers	43' 2"	43' 2"	34' 4"
<b>Width</b>			
Planting - Bulk Fill Hoppers	60' 10"	60' 10"	42'
Transport - Bulk Fill Hoppers	16' 2"	16' 2"	16' 2"
<b>Height</b>			
Planting - Bulk Fill Hoppers	10' 4"	10' 4"	9' 8"
Transport - Bulk Fill Hoppers	12' 4"	12' 4"	12' 4"
<b>Weight (Empty)</b>			
Base Machine - Bulk Fill Hoppers*	32,000 - 37,400 lbs.	30,000 - 34,820 lbs.	26,460 - 27,210 lbs.
Hitch - Bulk Fill Hoppers	9,620 lbs.	8,000 lbs.	6,250 lbs.
*Base machine weight depends on how machine is equipped (meters, drives, hoppers, etc.)			

**Tractor Hydraulic Requirements @ 2350 PSI; with PTO Pump**

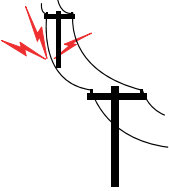
Vacuum Metering	GPM	SCV	Description
Blue Drive (Electric Drive) / Bulk Fill / Weight Distribution / Vacuum / True Rate or True Speed Meter / True Depth (Hydraulic Down Force / Fertilizer / Yetter Hydraulic Air Compressor	30	2	Planter Lift (Red Labels) Markers / Fold (Blue Labels)
NOTES: → All SCVs should be set to max flow at all times. → PTO Hydraulic pump comes standard on 5700 and supplies oil flow for all circuits (bulk fill, weight distribution, vacuum, True Rate or True Speed meters, True Depth hydraulic down force, fertilizer, Yetter hydraulic air compressor) except lift, markers/fold. → Consult your tractor manufacturer to ensure proper connection, hydraulic flow, pressure and heat dissipation.			

1. Read and understand instructions provided in this manual and warning labels. Review these instructions frequently!
  2. This machine is designed and built with your safety in mind. Do not make any alterations or changes to this machine. Any alteration to design or construction may create safety hazards.
  3. A large portion of farm accidents happen from fatigue or carelessness. Safe and careful operation of tractor and planter will help prevent accidents.
  4. Never allow planter to be operated by anyone unfamiliar with operation of all functions of the unit. Operators must read and thoroughly understand all instructions given in this manual before operating or working on equipment.
  5. Be aware of bystanders, particularly children! Always look around to make sure it is safe to start tow vehicle engine or move planter. This is particularly important with higher noise levels and quiet cabs, as you may not hear people shouting.
  6. Make sure planter weight does not exceed towing capacity of tractor, or bridge and road limits. This is critical to maintain safe control and prevent death or injury, or property and equipment damage.
  7. Never ride or allow others to ride on planter.
  8. Store planter in an area away from human activity. DO NOT permit children to play on or around the stored unit.
  9. Keep hands, feet, and clothing away from moving parts. Do not wear loose-fitting clothing which may catch in moving parts.
  10. Always wear protective clothing, shoes, gloves, hearing, and eye protection applicable for the situation.
  11. Do not allow anyone to stand between tongue or hitch and towing vehicle when backing up to planter.
  13. Prevent electrocution, other injuries, or property and equipment damage. Watch for obstructions such as wires, tree limbs, etc. when operating machine. Be aware of clearances during turns and when folding/unfolding planter.
  14. Reinstall all guards removed for maintenance activities. Never leave guards off during operation.
  15. Use of aftermarket hydraulic, electric, or PTO drives may create serious safety hazards to you and people nearby. If you install such drives, follow all appropriate safety standards and practices to protect you and others near this planter from injury.
  16. Follow all federal, state/provincial, and local regulations when towing farm equipment on a public highway. Use safety chain (not an elastic or nylon/plastic tow strap) to retain connection between towing and towed machines in the event of primary attaching system separation.
  17. Make sure all safety/warning lights, SMV sign, and reflective decals are in place and working properly before transporting the machine on public roads.
  18. Limit towing speed to 20 km/h. Tow only with a farm tractor equipped with a minimum of a Cat 4 hitch. Allow for unit length when making turns.
  19. Reduce speed prior to turns to avoid the risk of overturning. Always drive at a safe speed relative to local conditions and ensure your speed is slow enough for a safe emergency stop.
  20. Chemical application is often an integral part of planting. Follow label instructions for proper chemical mixing, handling and container disposal methods.
  21. Be familiar with safety procedures for immediate first aid should you accidentally contact chemical substances.
  22. Use the proper protective clothing and safety equipment when handling chemicals.
  23. Chemicals are supplied with Material Safety Data Sheets (MSDS) that provide full information about the chemical, its effects on exposure, and first aid needs in the event of an emergency. Keep your MSDS file up-to-date and available for first responders in case of emergency.
  24. When servicing ground engaging components such as opening disks and firming points, use special care to avoid points and edges worn sharp during use.
  25. Use professional help if you are unfamiliar with working on hydraulic systems. Pressurized hydraulic fluid can penetrate body tissue and result in death, serious infection, or other injuries.
  26. Disposing of waste improperly can threaten the environment. To dispose of your equipment properly contact your local environmental or recycling center.
- Never pour waste onto the ground, down a drain, or into any water source.
- When disposing of waste such as oil, use leakproof containers. Be sure to use containers that do not resemble food or beverage which may mislead someone into consuming them. Dispose of oil per your local, regional requirements.
- When disposing of any fertilizer chemicals used, contact the supplier of the chemicals.
- Model 5700 planter consists of 85% recyclable metals, 10% recyclable plastic and rubber, and 5% waste.

Following are some common hazard warnings associated with this equipment. Pay close attention to all safety, operating, and maintenance information in this manual and decals applied to your equipment.

 <p><b>DANGER</b></p> 	<p>Contacting or coming close to power lines or other high energy sources will cause death or serious injury.</p> <p>Keep away from power lines or high energy sources at all times.</p>
 <p><b>WARNING</b></p> 	<p>Improperly operating or working on this equipment could result in death or serious injury. Read and follow all instructions in Operator Manual before operating or working on this equipment.</p>
 <p><b>WARNING</b></p> 	<p>Falling equipment can cause death or serious injury. Install all lockup devices or lower planter to ground before working on equipment.</p>
 <p><b>WARNING</b></p> 	<p>Explosive separation of rim and tire parts can cause death or serious injury. Overinflation, rim and tire servicing, improper use of rims and tires, or worn or improperly maintained tires could result in a tire explosion.</p>

## SAFETY SIGNS AND DECALS

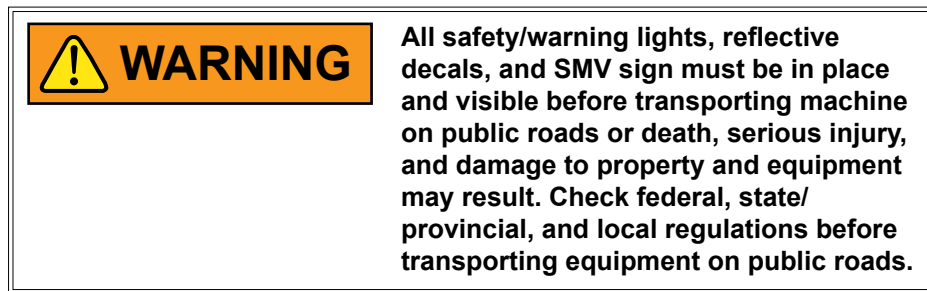

Safety signs and decals are placed on the machine to warn of hazards and provide important operating and maintenance instructions. Information on these signs are for your personal safety and the safety of those around you. FOLLOW ALL SAFETY INSTRUCTIONS!



- **Keep signs clean so they can be easily seen. Wash with soap and water or cleaning solution as required.**
- **Replace safety signs if damaged, painted over, or missing.**
- **Check reflective decals and SMV sign periodically. Replace if they show any loss of reflective properties.**
- **When replacing decals, clean machine surface thoroughly with soap and water or cleaning solution to remove all dirt and grease.**

**NOTE:** Safety sign and decal locations are shown in the Parts Manual for this machine.

**NOTE:** Style and locations of SMV sign, reflective decals, and safety/warning lights conform to ANSI/ASABE S279.14 JUL 2008 and ANSI/ASABE S276.6 JAN 2005.



**ROW MARKER SAFETY LOCKUP**

 <b>WARNING</b>	Row marker can lower at any time and could cause death or serious injury. Stay away from row markers! Install safety lockup device when not in use.
	



**Row Marker Safety Lockup Stored**



**Row Marker Safety Lockup Installed**

Always install row marker lockups when working on, storing, or transporting planter. Hold in place with two clevis pins.

## TRANSPORT AXLE CYLINDER SAFETY LOCKUP



### WARNING

Transport axle can lower from transport position without the use of any controller, causing death, serious injury, or damage to property and equipment. Do not operate any hydraulic function while transporting the planter. Make sure all transport safety lockups are installed on the four transport cylinders and all SCV controls are in their neutral state before transporting, storing and working on the planter.



**Transport axle cylinder lockup installed**



**Cylinder lockup storage location**

Transport axle cylinder lockups are required on both transport cylinders on planter when working on, storing, or transporting planter.

Fully extend cylinder to raised position. Install transport axle cylinder lockups. Insert wire lock pin through holes on cylinder lockup and secure.

Store transport axle cylinder lockups in cylinder lockup storage location before operating planter.

**WARNING**

Tanks must be empty when transporting to avoid death, serious injury, or damage to property or equipment. Do not pull planters in transport configuration with seed or fertilizer in tanks.

**WARNING**

Planter hitch may raise uncontrollably during folding/unfolding and can cause death, serious injury, or damage property and equipment. **DO NOT** fold or unfold planter without planter attached to a tractor. **DO NOT** unhitch planter from tractor unless fully folded for transport or fully unfolded with planting units lowered to ground.

**WARNING**

Uncontrolled movement of equipment can cause loss of control and could result in death, serious injury, or damage to property and equipment. Install all safety pins before transporting equipment.

## DRAWBAR HITCH LOCKUP

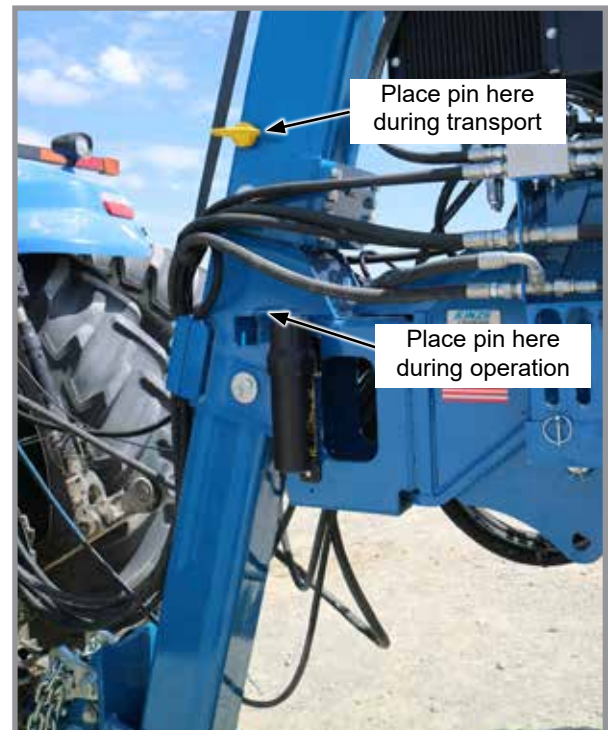

Place the drawbar hitch lockup pin in the hole on hitch when machine is in operation. Place pin in storage location while in operation.



### WING LATCH LOCKUP





Hitch Release from Wing Latch

 <b>WARNING</b>	<p>Improperly operating or working on this equipment could result in death or serious injury. Read and follow all instructions in Operator Manual before operating or working on this equipment.</p>
	

### INITIAL PLANTER PREPARATION

Following information is general in nature to aid in preparation of tractor and planter for use, and to provide general operating procedures. Operator experience, familiarity with the machine, and the following information should combine for efficient planter operation and good working habits.

 <b>WARNING</b>	<p>Explosive separation of rim and tire parts can cause death or serious injury. Overinflation, rim and tire servicing, improper use of rims and tires, or worn or improperly maintained tires could result in a tire explosion.</p>
	

 <b>WARNING</b>	<p>Wheel separation can cause loss of control resulting in death, serious injury, or damage to property and equipment. Check lug nuts on transport wheels are tight before operating planter for first time and periodically after.</p>
--	---

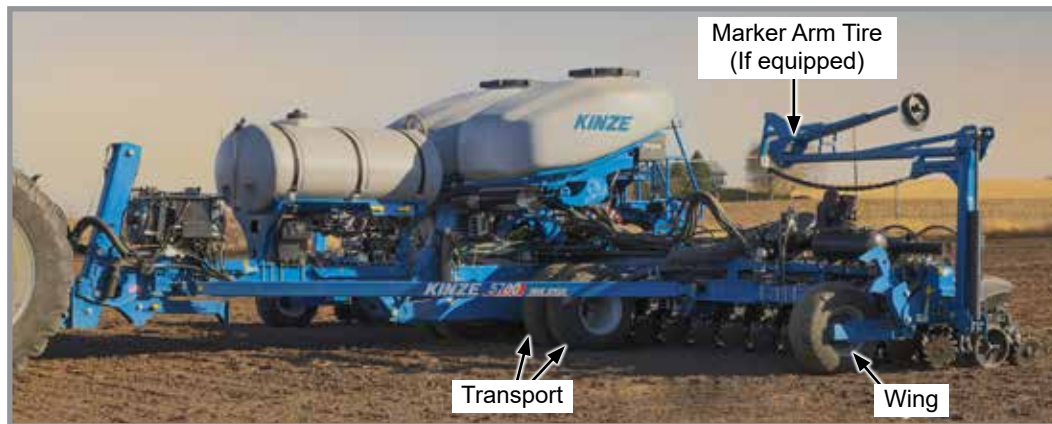

**Tire Locations (L.H. shown)**

1. Torque transport wheel  $\frac{3}{4}$ "- 16 lug nuts to 315 ft-lb.
2. Torque wing wheel  $\frac{5}{8}$ "-18 lug nuts to 200 ft-lb.
3. Inflate tires to the following specifications:

Transport Tire Size (4)	445/50R 22.5	440/55R18
Transport Tire Pressure	81 PSI	73 PSI
Wing (Field) Tire Size	380/55R 16.5 (4)	380/55R 16.5 (2)
Wing (Field) Tire Pressure	65 PSI	65 PSI
Marker Arm Tire Size (2)	16" x 6 $\frac{1}{2}$ " x 8"	N/A
Marker Arm Tire Pressure	14 PSI	N/A

4. Lubricate planter and row units per lubrication information in this manual.

---

**TRACTOR REQUIREMENTS****WARNING**

Loss of control of equipment during transport can result in death, serious injury, or damage to property and equipment. Tractor gross weight must be greater than planter gross weight with attachments and options.

**NOTICE**

Connect hydraulic motor case drain to a case drain return line with zero PSI on tractor. Failure to connect to a return with zero PSI will cause hydraulic motor shaft seal damage. **DO NOT** connect hydraulic motor case drain to a SCV outlet or motor return circuit connection. Contact tractor manufacturer for specific details on “zero pressure return”.

**NOTICE**

**All Hydraulic Requirements: Minimum Pressure 2350 PSI (16200 kPa); Maximum Pressure 3000 PSI (20700 kPa). Check tractor hydraulics to ensure that maximum pressure cannot be exceeded.**

Consult your dealer for information on horsepower requirements and tractor compatibility. Requirements vary with planter options, tillage, and terrain.

Two dual remote hydraulic outlets (SCV) are required on all sizes of bulk fill planters equipped with row markers. A 12 volt DC electrical system is required on all sizes.

## BULK FILL TRACTOR MOUNTED PTO PUMP AND PLANTER MOUNTED HYDRAULICS



20 gal (75.7 L) Reservoir

Bulk fill/vacuum meter equipped planters require a 1 $\frac{3}{4}$ " (45 mm)-20 or 1 $\frac{3}{8}$ "(35 mm)-21 spline 1000 RPM PTO to operate PTO-driven hydraulic pump capable of supplying 26 gal/min to vacuum and bulk fill fans.

**NOTE: A tractor model-specific mount kit is required for the PTO-mounted pump.**

Contact Command Hydraulics (800-778-6200 or [www.commandhydraulics.com](http://www.commandhydraulics.com)) for your tractor pump mount requirements.

Vacuum Seed Metering System operates from a 8 gallon capacity oil reservoir.

**NOTE: Check that open center plug is removed from fan block before operating.**

Other dual fan system components include one oil cooler, one replaceable cartridge-type filter and two high pressure filters.

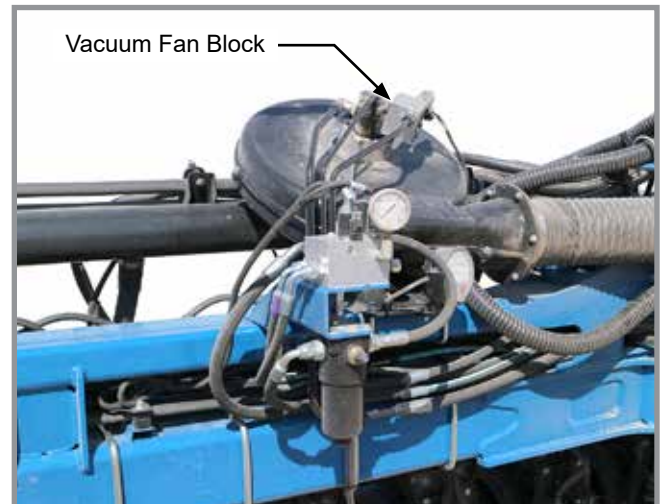

Vacuum Fan Block

## TRACTOR PREPARATION AND HOOKUP

1. Back tractor to planter and connect with minimum 1¼" (32 mm) diameter hitch pin or 2 point hitch. Make sure hitch pin is secured with a locking pin or cotter pin if tractor is not equipped with a hitch pin locking device.

**NOTE: DO NOT install safety chain using clevis mounting hardware. Safety chain MUST be installed separately.**

2. For planters with drawbar hitch, safety chain must be used to keep planter and tractor connected in case of a hitch pin/drawbar failure. Attach safety chain at an unused clevis mounting hole on the planter hitch. Torque hardware to 840 ft-lb (1140 Nm).



**Tractor and Safety Chain Hookup  
for Drawbar Hitch**



**NOTICE**

Routing of hydraulic hoses from planter to tractor is very important. If done improperly, hoses can be pinched, cut or broken when planter is operated.

**WARNING**

Pressurized hydraulic fluid can penetrate body tissue and result in death, serious infection, or other injuries. Fluid injected under skin must be **IMMEDIATELY** removed by a surgeon familiar with this type of injury. Make sure connections are tight and hoses and fittings are not damaged before applying system pressure. Leaks can be invisible. Keep away from suspected leaks. Relieve pressure before searching for leaks or performing any system maintenance.

**NOTICE**

Wipe hose ends to remove any dirt before connecting couplers to tractor ports or contamination may cause equipment failure.

**NOTICE**

Always connect hydraulic motor return hose to tractor motor return port. Do not connect to tractor SCV unless through a motor spool or hydraulic motor failure can occur. If a motor return port is not available on the tractor, the SCV controlling the bulk fill system **MUST** be in the float position before planter is moved in planting or field raised position when bulk fill system is not in use.

3. Connect hydraulic hoses to tractor ports in a sequence familiar and comfortable to the operator. Refer to chart on the following page.

Color and Label	Machine Function	Hose Size	Hose Function
Red AA	Field Lift (Hydraulic Weight Transfer)	1/2"	Pressure/Return
Red BB		1/2"	Pressure/Return
Blue AA	Planter Fold & Row Marker	3/8"	Pressure/Return
Blue BB		3/8"	Pressure/Return
Black RR	Power Pack	5/8"	Return
Black PP		1/2"	Pressure
Yellow RR	Bulk Fill System Pressure Fan	5/8"	Return
Yellow PP		1/2"	Pressure
Orange CD	Power Pack/Bulk Fill System Pressure Fan	3/8"	Case Drain

<b>NOTICE</b>	<p><b>Clean and grease PTO shaft coupling with high-pressure industrial coupling grease (Chevron® coupling grease or equivalent) meeting AGMA CG-1 and CG-2 Standards each time driveshaft is installed or premature wear and equipment failure can occur.</b></p>
---------------	--

**NOTE: A tractor model-specific PTO mount kit for dual section pump option is required and available from Command Hydraulics (800-778-6200 or [www.commandhydraulics.com](http://www.commandhydraulics.com)).**

4. (If applicable) Install PTO pump onto tractor PTO shaft. Make sure shaft rotation matches direction indicated on pump housing.
5. If equipped with ISOBUS system, attach ISO connector.
6. For planters not equipped with ISOBUS, connect ASABE Standards 7 terminal connector for safety/warning lights on planter to ASABE Standards receptacle on tractor. If your tractor is not equipped with an ASABE Standards receptacle, check with your tractor manufacturer for availability. Check warning lights on planter work in conjunction with warning lights on tractor.
7. Completely raise parking stands, located behind drawbar hitch, to prevent damage to stands and equipment when moving planter.
8. Attach Blue Drive 6-pin connector and ethernet cable to the Blue Vantage Display.

**TRUE DEPTH HYDRAULIC SYSTEM OVERVIEW**



**True Depth Pressure Gauge**

 <b>WARNING</b>	Remove all hydraulic power sources and verify True Depth pressure gauge reads zero before servicing.
--	--



**True Depth Cylinder**

 <b>WARNING</b>	Flow out of the rod end port of the cylinder must not be restricted when pressurizing cap end port as 4.5:1 pressure intensification will occur on the rod end of the cylinder potentially resulting in failure of the cylinder and loss of containment of the piston rod assembly.
--	---



True Depth Filter

**TRUE DEPTH FILTER**

Replace filter cartridge annually, every 100 hours of operation, or when the clogging indicators point out the limit pressure drop created inside the filter.

To replace the cartridge:



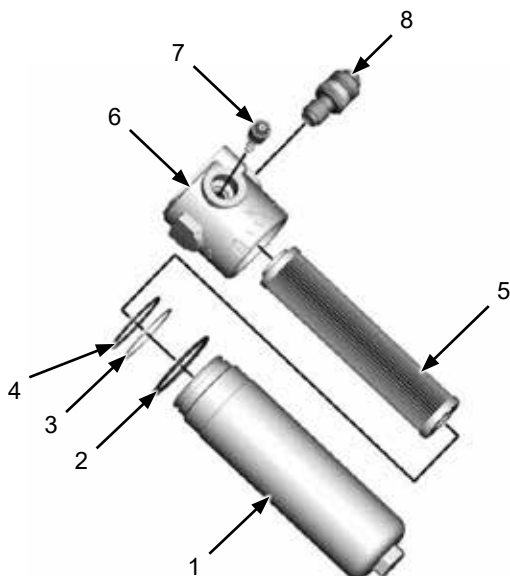



1. Stop the system in "Machine Stopped" status
2. Secure any shut-off valves on the hydraulic circuit.
3. Unscrew the filter container (1).
4. Remove the clogged filtering cartridge (5), making sure no residual particles have settled in the bowl bottom.
5. Make sure the O-ring (2-4) and the anti-extrusion ring (3) are not damaged, otherwise replace them and consequently position the new ones correctly.
6. Insert the new filtering cartridge, lubricating the sealing O-ring beforehand.
7. Screw the container tight (1) making sure the threading is screwed correctly. Tighten to a tightening torque of 65 Nm.
8. Start the machine for a few minutes.
9. Make sure there are no leaks.



1. Filter Bowl
2. External O-Ring
3. Anti-extrusion ring
4. Sealing O-Ring
5. Filtering Element
6. Filter Head
7. By-pass valve
8. Visual differential indicator

True Depth Cylinder

## TRANSPORTING PLANTER

- |   |  |
|---|--|
|  <b>WARNING</b><br> | <p>Uncontrolled movement of equipment can cause loss of control and could result in death, serious injury, or damage to property and equipment. Install all safety pins before transporting equipment.</p>   |
|  <b>WARNING</b><br> | <p>Uncontrolled machine movement can crush or cause loss of control resulting in death, serious injury, or damage to property and equipment. Install all safety lockup devices before working under or transporting this equipment.</p>  |
|  <b>WARNING</b>  | <p>Transporting planter with hoppers over half full or unevenly loaded can cause loss of control and could result in death, serious injury, or damage to property and equipment. Properly load planter when transporting. Be aware of extra transport weight, and road conditions and limits.</p>  |
|  <b>WARNING</b>  | <p>To avoid unintended movement of axle during transport, return all SCV controls to the neutral position before transporting machine. <b>DO NOT</b> operate any hydraulic function while transporting machine. Doing so could result in death, serious injury, or damage to property and equipment.</p>   |
|  <b>WARNING</b>  | <p>Transport axle can lower from transport position without the use of any controller, causing death, serious injury, or damage to property and equipment. Do not operate any hydraulic function while transporting the planter. Make sure all transport safety lockups are installed on the four transport cylinders and all SCV controls are in their neutral state before transporting, storing and working on the planter.</p> |

Make sure safety/warning lights, reflective decals, and SMV sign are in place and visible before transporting machine on public roads. It is your responsibility to check and comply with all federal, state/provincial, and local regulations.

Be aware of road and bridge weight limits. Allow for additional weight of added options and any additional material or substances that have been added to the machine.

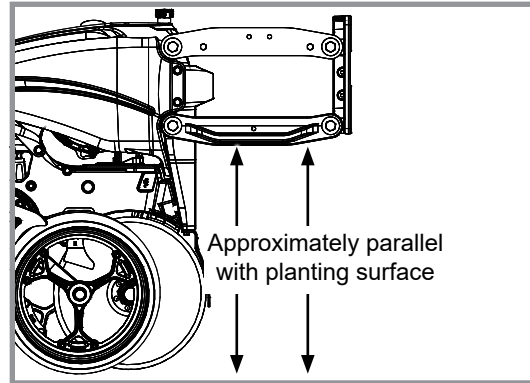
**LEVEL PLANTER****Clevis Adjustment Holes****Level Row Units**

Toolbar should operate at 23"-25" height from planting surface. Tire pressures must be maintained at pressures specified for planter to operate level laterally. Check toolbar and row unit parallel arms are level front to back with planter lowered to proper operating height.

Field and actual planting conditions determine which wheel settings to use to ensure row unit parallel arms are approximately parallel with planting surface. If planting in extremely soft soil conditions it may be necessary to move ground drive tires to lower sets of mounting holes. To allow adequate drive force after lowering the ground drive tires, it may be necessary to lower contact drive arms to lower set of holes in wheel module and relocate down pressure springs to lower mounting rod on wheel module.

If planter center is higher or lower than wings after rephasing, contact your Kinze Dealer for valve adjustment or maintenance.

## JUMP START SENSOR

The jump start sensor is intended to reduce the seed gap when starting from a stop with the planter in the ground. For the jump start sensor to work as intended, the planter speed sensor needs to be set within  $\frac{1}{8}$ " of the pick-up disc. The planter speed sensor also needs to be calibrated properly and have the speed source set to automatic. Refer to Kinze Blue Vantage Operator's Manual for calibration instructions.

If the planter speed sensor is setup properly, the start-up gap should be no more than 4 feet. (1.2M)

If no gap is desired, there are two options for eliminating the gap completely:

1. Use the jump start button available on the Blue Vantage display. Pressing this button will start turning the drives. Once a speed source is acquired, it will take over control. Refer to the Blue Vantage Manual for further instructions on the jump start button.
2. Pick the planter up, back up 10 - 12 feet (3 - 3.6M), set the planter down and resume planting. The section control will turn the drives on at the correct time.



**Jump Start Sensor and Pick-up Disc**

## FIELD OPERATION

Planters are designed to operate within a speed range of 2-8 mph. Higher ground speeds can cause more variation in seed spacing. Speeds above 6.5 mph are typically not recommended.

### NOTICE

**Always raise planter out of ground when making sharp turns or backing up.**

Normal field planting operation requires use of tractor's hydraulic control to raise and lower planter frame when making field turnarounds.

### NOTICE

**Operate row markers in float position to prevent damage to row markers.**

Operate row markers with Blue Vantage control W/tractor's hydraulics. After markers are lowered to ground, move hydraulic control to operate markers in float position. Marker speed is controlled with flow control valves located on both planter wings. One valve controls raise speed and other valve controls lower speed of both markers.

**Refer to Kinze Blue Vantage Operator's Manual for marker control.**

## UNFOLD

**NOTICE**

Tractor must be in neutral and allowed to roll freely when folding to prevent equipment damage, especially in soft conditions or when loaded with seed or fertilizer. Use tractor assist as needed to aid in folding and to reduce stress on frame and transport components.

**NOTICE**

DO NOT fold or unfold planter without planter attached to a tractor. DO NOT unhitch planter from tractor unless fully folded for transport or fully unfolded with planting units lowered to ground.

**WARNING**

Improperly operating or working on this equipment could result in death or serious injury. Make sure there is no one in the area of the moving parts of the planter.

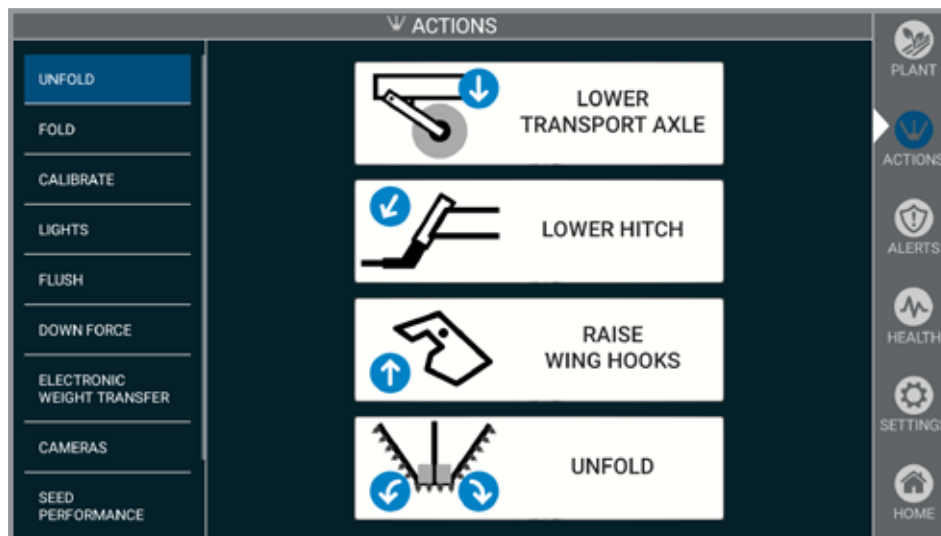

1. Remove the lockups.
2. Press and hold "LOWER TRANSPORT AXLE". Operate proper hydraulic tractor control to lower the transport axle to the field turnaround position.
3. Press and hold "LOWER HITCH". Operate proper hydraulic tractor control to lower the hitch.
4. Press and hold "RAISE WING HOOKS". Operate proper hydraulic tractor control to disengage the wing hooks.
5. Press and hold "UNFOLD". Operate proper hydraulic tractor control to fold the wings outward until the stub wing latch pins are sealed into the H-frame receivers.
6. Raise the hitch to level the machine during planting if necessary.



## FOLD

**NOTICE**

Tractor must be in neutral and allowed to roll freely when folding to prevent equipment damage, especially in soft conditions or when loaded with seed or fertilizer. Use tractor assist as needed to aid in folding and to reduce stress on frame and transport components.

**NOTICE**

DO NOT fold or unfold planter without planter attached to a tractor. DO NOT unhitch planter from tractor unless fully folded for transport or fully unfolded with planting units lowered to ground.

**WARNING**

Improperly operating or working on this equipment could result in death or serious injury. Make sure there is no one in the area of the moving parts of the planter.

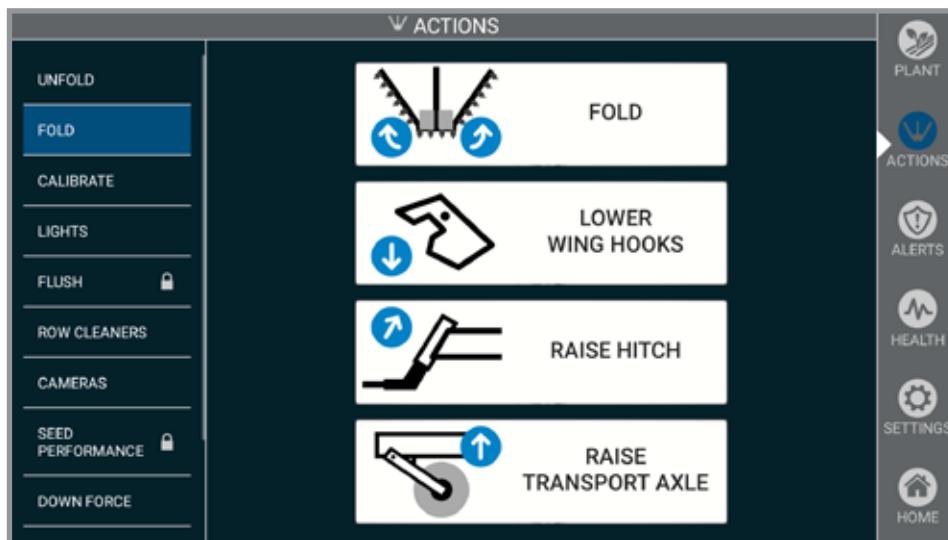

1. If equipped with row markers, remove the lockups from storage and marker cylinder rods.
2. Place the planter into the field turnaround position.
3. Press and hold "FOLD". Operate proper hydraulic tractor control to fold the wings in toward the tractor.
4. Press and hold "LOWER WING HOOKS". Operate proper hydraulic tractor control to engage the wing latches around the hitch tube to lock the wings.
5. Press and hold "RAISE HITCH". Operate proper hydraulic tractor control to raise the hitch to transport height.
6. Press and hold "RAISE TRANSPORT AXLE". Operate proper hydraulic tractor control to raise the transport axle to transport height.
7. Install the lockups.

---

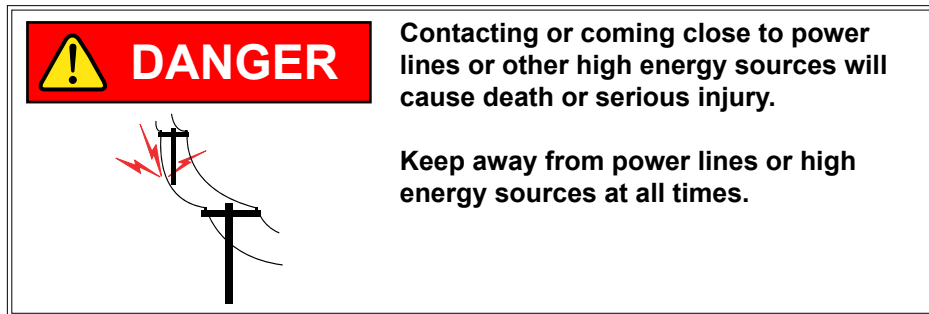
**ROW MARKER OPERATION USING BLUE VANTAGE DISPLAY**

**NOTE:** See row marker adjustments on following pages. If the planter is equipped with Blue Drive refer to M0288 - Kinze Blue Vantage Operator's Manual for marker control

## ROW MARKER SPEED ADJUSTMENT

### NOTICE

Excessive row marker travel speed can damage row markers. Adjust flow controls before row markers are first used.

**NOTE:** Row markers should not operate faster than 8 mph (13 kph).

Marker hydraulic system includes two flow control valves. One flow control valve sets lowering speed and one sets raising speed of both markers. Flow controls determine amount of oil flow restriction through valves, varying marker travel speed.

Row marker speed should be between 8-10 seconds. Loosen jam nut and turn control clockwise, or IN to slow travel speed. Turn counterclockwise, or OUT to increase travel speed. Tighten jam nut after adjustments are complete.

**NOTE:** Tractors with flow control valves. Make row marker speed adjustment with tractor flow controls in maximum position. After row marker speed is set, adjust tractor flow controls to allow hydraulic control to stay in detent during marker raise or lower cycle.

**NOTE:** Hydraulics operate slowly when oil is cold. Make all adjustments with oil warm.

**NOTE:** On a tractor where oil flow cannot be controlled, tractor flow rate may be greater than rate marker cylinder can accept. Hold tractor hydraulic control lever until cylinder reaches end of its stroke. This occurs most often on tractors with an open center hydraulic system.

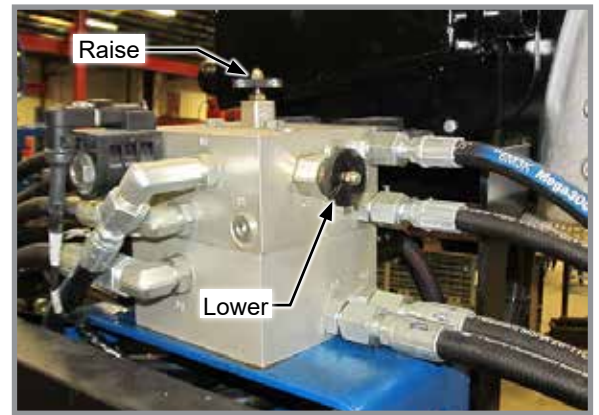

Row Marker Speed Control Adjustment

## ROW MARKER CABLE ADJUSTMENT

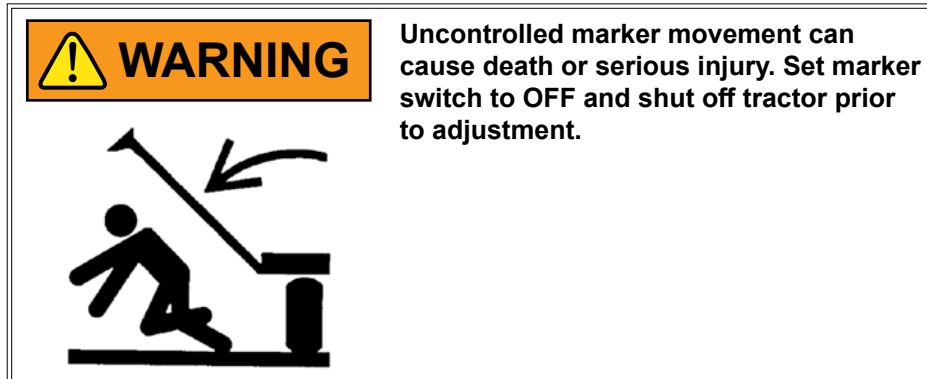

**NOTE:** Operate two-fold or three-fold row markers with the tractor's hydraulic valve in float position.

**NOTE:** A cable or chain may be used. For continuity, cable will be used in this manual.

Cable adjustment is critical. Adjust with second stage of marker in vertical position and first stage in horizontal position.

Cable must be adjusted so third stage of marker is pulled out as soon as second stage begins outward travel. Cable stretches with use and needs routine adjustment. It may be necessary to twist for a finer adjustment.

Marker cable is PROPERLY ADJUSTED if marker blade pushes dirt 12" or less as marker completes fold into field operating position. Cable should have some slack when marker is in field operating position.

Marker cable is TOO LOOSE and should be adjusted if marker blade pushes dirt more than 12" as it completes the fold into field operating position.

Marker cable is TOO TIGHT if it will not allow marker blade to follow ground contour and cable is tight when marker is in field operating position.

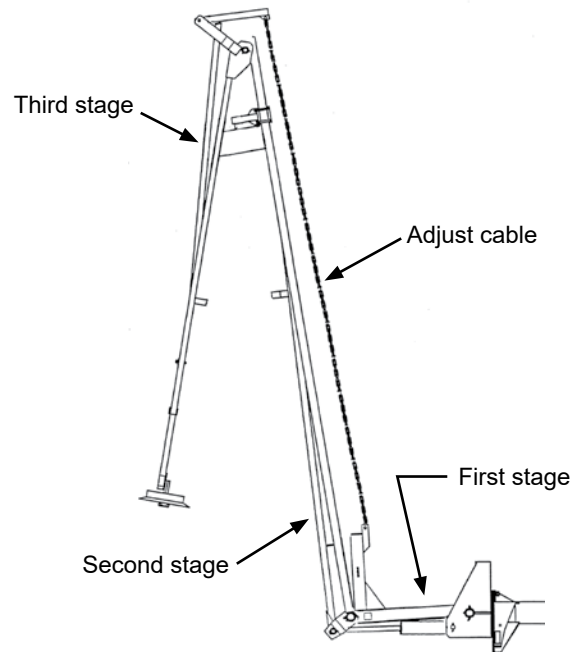

## ROW MARKER LENGTH AND DISC BLADE ADJUSTMENT

1. Lower planter and row marker assembly to ground.
2. Adjust row marker extensions according to table below. Measurements can be taken from the centerline of planter or the last furrow on either side of planter. The dimensions shown are a starting point and may need to be adjusted.

Adjusting Row Marker Lengths		
	Distance from Planter Centerline	Distance from Outside Furrow
24 Row 20" (40 Foot Toolbar)	480"	250"
24 Row 30" (60 Foot Toolbar)	720"	375"
36 Row 20" (60 Foot Toolbar)	720"	370"

3. Adjust marker disc blade. Marker disc blade is installed with concave side facing inward. Spindle assembly is slotted so hub and blade can be angled to throw more or less dirt.
4. Tighten hardware to specified torque.
5. Perform a field test to ensure markers are properly adjusted.

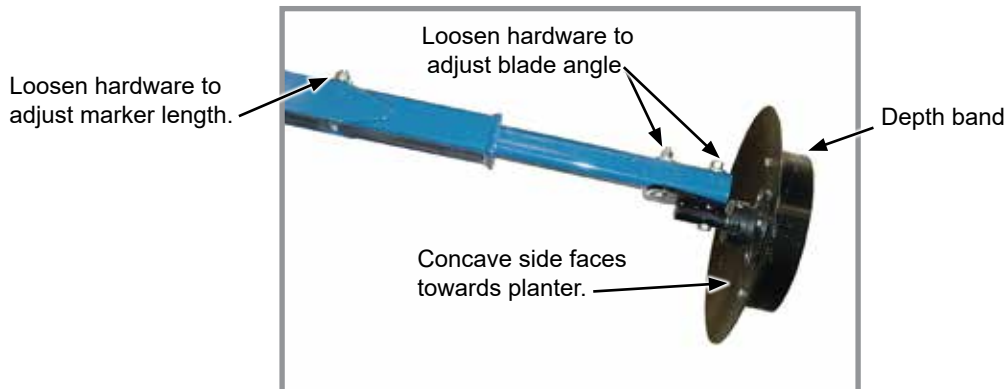

**Row Marker Disc Blade Angle Adjustment**

### NOTICE

Setting marker disc blade assembly at a sharper angle than needed adds stress to row marker assembly and shortens bearing and blade life. Set blade angle only as needed to leave a clear mark.

**NOTE:** A notched marker blade is available from Kinze through your Kinze Dealer for use in more severe no till conditions.

## VACUUM METER SYSTEM

Kinze vacuum meter seed metering system includes seed meters, seed discs, and an air system consisting of a hydraulic driven vacuum fan which draws air through manifolds, hoses, and seed meters on each row unit.

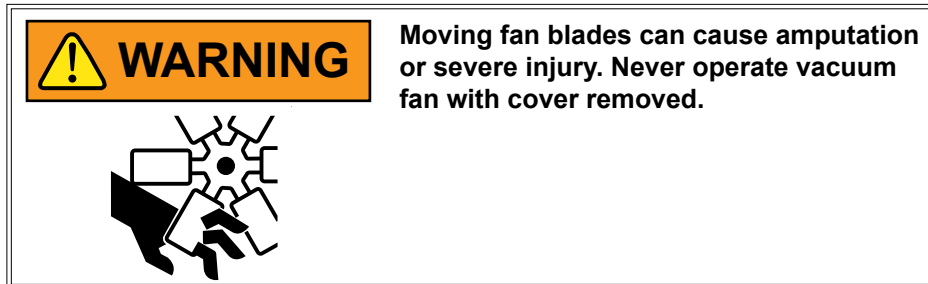

## ANALOG VACUUM OR PRESSURE GAUGE

Analog vacuum or pressure gauge connects directly to vacuum manifold (vacuum) or bulk fill (pressure) manifold and is teed into digital sending units.

Only adjustment is to “zero” needle with no vacuum or pressure present. If there is a significant difference between gauge and a reading taken at meters, a different manifold location should be found to connect hose to gauge and digital sending unit.

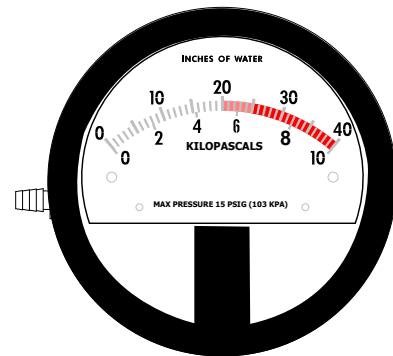

**Analog Gauge**

**NOTE:** Analog gauges are identical EXCEPT for plug and hose barb locations in side of gauge housing. DO NOT connect vacuum meter or bulk fill hose to wrong gauge. Check plug and hose barb installation if readout is erratic or appears inaccurate.

**BULK FILL SYSTEM****WARNING**

Do not remove lid during machine operation. Contents are pressurized and could result in death, serious injuries or equipment damage.

Review operator manual for proper filling procedure.

**CAUTION**

Seed flying out of disconnected delivery tube at high velocity can cause injury. Do not disconnect delivery tubes when system is operating.

**DANGER**

**DO NOT ENTER.** Hazardous conditions inside will result in death or serious injury. Follow OSHA confined space procedures.

**NOTICE**

Foreign materials can plug system. Make sure seed is clean and free of debris when filling bulk fill hoppers.

**NOTICE**

Do not turn on system with tractor engine at full speed or system damage may occur.

**NOTICE**

Do not operate bulk fill system above maximum system operating pressure of 20 inches of water or seed bridging may occur.

**WARNING**

Transporting planter with hoppers over half full or unevenly loaded can cause loss of control and could result in death, serious injury, or damage to property and equipment. Properly load planter when transporting. Be aware of extra transport weight, and road conditions and limits.

1. **Before filling hoppers, refer to “Row Marker Speed Adjustment” on page 2-19 for additives information.** Fill hoppers with seed, then twist lid clockwise to close.
2. Start bulk fill delivery system with tractor engine at idle.
3. Increase engine speed to full and set initial system pressure using flow control valve.
4. Allow system to warm up and adjust pressure if necessary.



Bulk Fill Lid

Recommended pressures:

- Corn – 12 inches (30.5 cm) of water
- Soybeans – 10 inches (25.4 cm) of water
- Actual pressure needed is affected by seed size, shape, and coating.

### BULK FILL ENTRAINER ACCESS

1. Shut down bulk fill system.
2. Pull pin holding entrainer slide in place and remove.
3. Remove rubber plug closest to area in entrainer needing attention.
4. Insert entrainer slide into open slot and push into entrainer at a slight upward angle.
5. When work is complete, remove entrainer slide, return slide to storage location, and plug open slot.

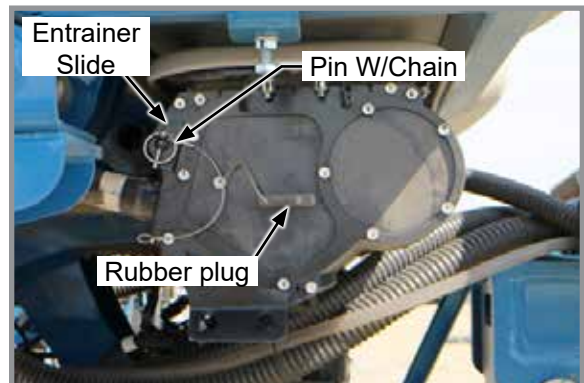

Bulk Fill Entrainer (End View)

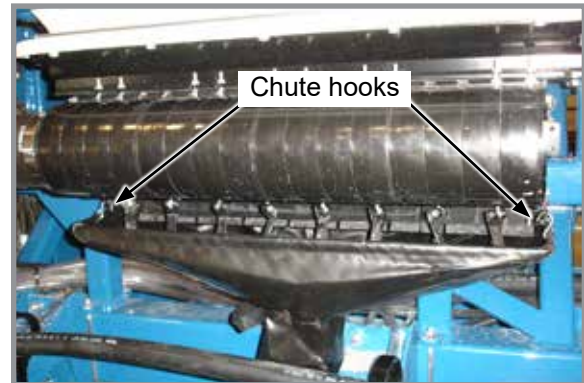

**BULK FILL TANKS - CLEAN OUT****Cleanout Chute Storage Location****Cleanout Chute Installed**

1. Remove bulk fill tank cleanout chute from storage location under L.H. bulk fill tank.
2. Position tube of chute under entrainer and attach hooks on each end of entrainment assembly.
3. Open cleanout doors and empty tank.
4. Close all cleanout doors and return cleanout chute to storage location.

**BULK FILL SCALE PACKAGE OPTION****NOTICE**

High-pressure water can damage display. Remove display before power washing planter.

**NOTICE**

Remove and store display at end of planting season. Damage from sun and weather exposure may result.

**Bulk Fill Scale Package is capable of:**

- Displaying seed weights and estimated acres remaining for bulk fill hoppers separately.
- Setting alarm to warn operator when seed goes below a pre-defined level.

**NOTE:** Operation of Bulk Fill Scale Package display is controlled by touchscreen.

**NOTE:** Screen position is changed by loosening the thumb screw on RAM™ mount.

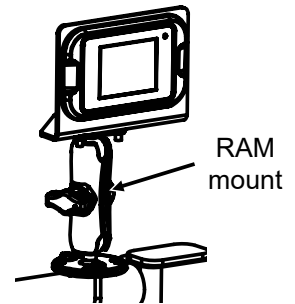

To monitor seed levels (Main Screen):

**NOTE:** Refer to Blue Vantage manual for bulk fill scale user information.

1. Main screen displays information for left and right hoppers.
2. Tap "Weight" to display left and right hopper weight.
3. Tap "Area to Empty" to display left and right acres to empty.



4. Tap either "L" or "R" to display detailed hopper screen.

**NOTE:** "Zero" is selected to zero hopper that is selected. If hopper(s) is zeroed out with seed, weight in hopper will not be recognized. To reset hopper correctly seed must be emptied from hopper(s) and then zeroed to reset.



5. Tap "Back" to return to main screen.
6. Tap "Planter Setup" to enter Seed information. See follow page for more information.

To enter seed information (Not applicable on Blue Vantage):

**NOTE: Seed information entered must be accurate for remaining estimated acres to calculate correctly.**

- SEEDS/ACRE is population rate.
- SEEDS/LB value comes from seed specifications.

1. From main screen, tap "Planter Setup".
2. From planter setup screen, tap "Seed Setup".

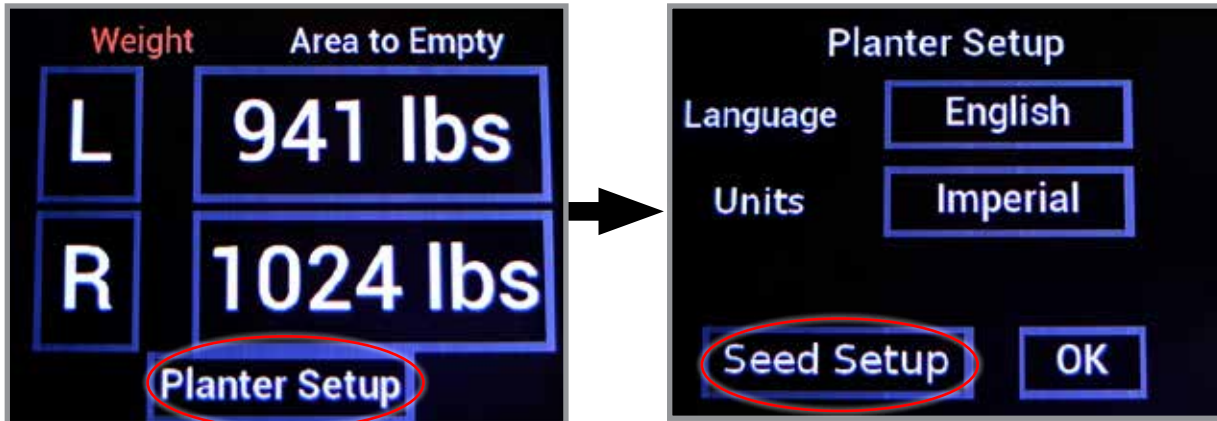

3. To change values in either "Seeds/Ac", "Seeds/lb", or "Alarm Level" tap in appropriate box.
4. At input screen, enter desired value. Tap "OK".



5. Once desired values have been entered tap "OK", to confirm changes tap "Accept" to return to main screen.

**NOTE: It is NOT RECOMMENDED to make adjustments to setup in the "Scale Setup" screen.**

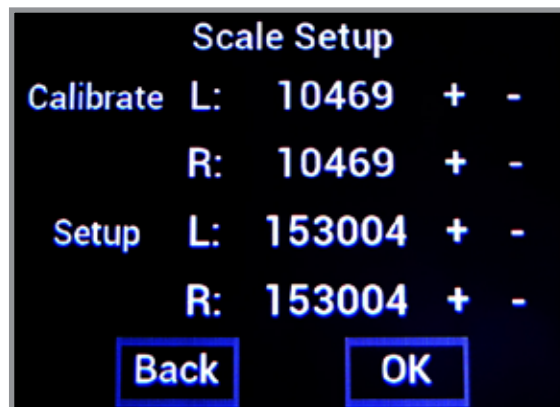

**Software Version:**

1. From main screen, tap "Planter Setup".
2. Tap on "English" to display software version.

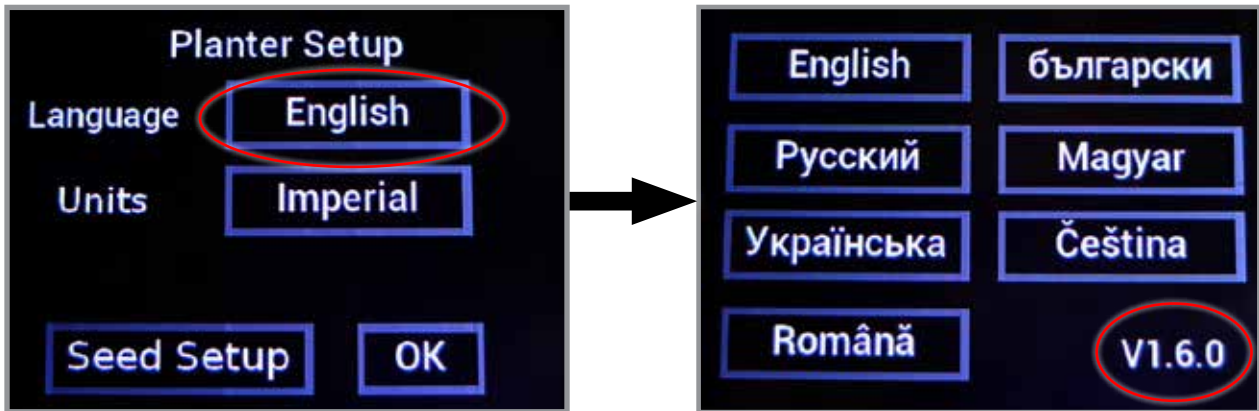

4. Tap "English" to return to planter setup screen.
3. Tap "OK" to return to main screen.

**Language/Units:**

**NOTE: English is the default language. Imperial is the default units.**

1. From main screen, tap "Planter Setup".
2. Tap on "English" to display language options.

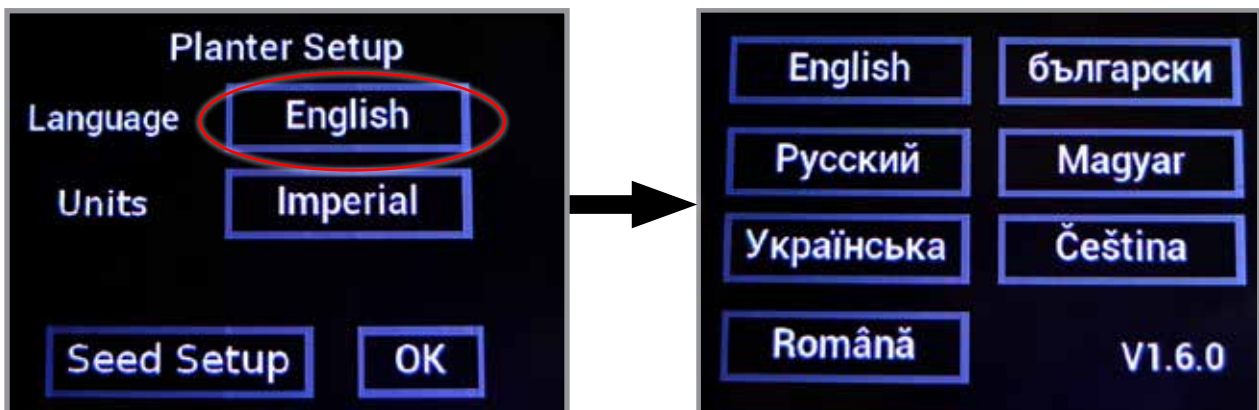

3. Tap on desired language to select and return to planter setup screen.
4. Tap on "Imperial" to switch to metric units and vice versa.

**NOTE: If units are switched back and forth between imperial and metric, measurements will round up each time.**

3. Tap "OK" to return to main screen.

## KINZE BLUE VANTAGE

Blue Vantage can be ready to plant in three taps after proper setup. The health screen provides all critical planting parameters and controls. The grower can observe row-by-row planting performance in real-time.

**NOTE: See Kinze Blue Vantage Operator's Manual for system operation and programming.**



**Kinze Blue Vantage**

## FIELD TEST

Perform a field test with any change of field and/or planting conditions, seed size or planter adjustment to ensure proper seed placement and operation of row units.

- Check planter for front to rear and lateral level operation. See [“Level Planter” on page 2-14](#)
- Check **all** row units to be certain they are running level. Row unit parallel arms should be approximately parallel to the ground when planting.
- Check row markers for proper operation and adjustment. See [“Row Marker Speed Adjustment” on page 2-19](#), [“Row Marker Cable Adjustment” on page 2-20](#), [“Row Marker Length And Disc Blade Adjustment” on page 2-21](#)
- Check for desired depth placement and seed population on **all** rows. See [“Field Check Seed Population” on page 2-32](#)
- Check for proper application rates of fertilizer on **all** rows.

Reinspect machine after field testing.

- Hoses And Fittings
- Bolts And Nuts
- Cotter Pins And Spring Pins
- Drive Chain Alignment
- Confirm ASD and dry fertilizer hoses were not crushed during fold/unfold operation.

**FIELD CHECK SEED POPULATION**

1. Remove locking cotter pin.
2. Lock up one or more sets of closing wheels putting in locked position.
3. Pull closing wheel arm up and align with lock up hole. Secure with 1/2" x 3/2" clevis pin and locking cotter pin.

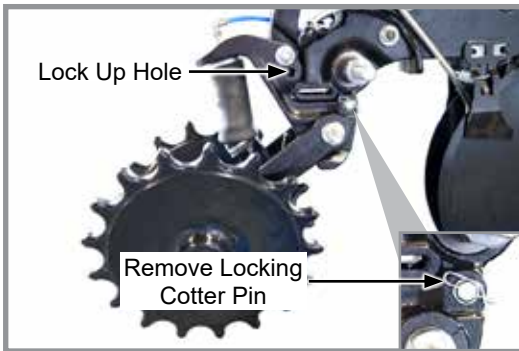

Closing Wheels in Lowered Position



Closing Wheels in Raised Position

4. Plant a short distance and check to see if seed is visible in the seed trench. Adjust planting depth to a shallower setting if seed is not visible and recheck.

Planting depth adjustment handle



Planting Depth Adjustment

5. Measure 1/1000 of an acre. See chart for correct distance for row width being planted. For example, planting 30" rows 1/1000 of an acre is 17' 5".

1/1000 Acre Seed Population Count Row Width/ Distance		
	20" Rows	30" Rows
Distance	26'2" (66.5 cm)	17'5" (44.4 cm)

**NOTE: Seeds may bounce or roll when planting with closing wheels raised and planting depth set shallow affecting seed spacing accuracy.**

6. Count seeds in measured distance.



7. Multiply number of seeds placed in  $\frac{1}{1000}$  of an acre by 1000. This gives total population.

EXAMPLE: 30" row spacing 17' 5" equals  $\frac{1}{1000}$  acre.

26 seeds counted x 1000 = 26,000 seeds per acre

## DETERMINING POUNDS PER ACRE

Seeds per acre  $\div$  Seeds per pound (from label) = Pounds per acre

If seeds per pound information is not available use the following averages:

2,600 seeds per pound for medium size soybeans

15,000 seeds per pound for medium size milo/grain sorghum

4,500 seeds per pound for medium size cotton

## DETERMINING BUSHELS PER ACRE

Pounds per acre  $\div$  Seed unit weight = Bushels per acre

Average Unit Weight of:



1 Bushel Soybeans = 60 Pounds (27.2 kg)

1 Bushel Milo/Grain Sorghum = 56 Pounds (25.4 kg)

1 Bushel Cotton = 32 Pounds (14.5 kg)

## FIELD CHECK GRANULAR CHEMICAL APPLICATION

Temperature, humidity, speed, ground conditions, flowability of different material, or meter obstructions can affect granular chemical rate of delivery.



 <b>WARNING</b>	<b>Agricultural chemicals can cause death or serious injury to persons, animals, and plants or seriously damage soil, equipment, or property. Read and follow all chemical and equipment manufacturers labels and instructions.</b>
	

Perform a field check to determine application rates.



1. Fill insecticide and/or herbicide hoppers.
2. Place a container under hopper to catch the insecticide.
3. Push the manual run button until it times out. **NOTE: Insecticide will be delivered at 25 RPM for 10 seconds.**
4. Weigh insecticide in grams.
5. Multiply the number of grams by 1.1758 to get density.
6. If using multiple rows, average these numbers to get a more accurate value.

**NOTE: Check calibration of all rows.**

## YETTER 2940 AIR ADJUST RESIDUE MANAGER

 <b>DANGER</b>	<p>Serious injury or death may occur if modifications are made to water separator valve, pressure switch, safety relief valve or other components that control tank pressure.</p>
	<p>Never make adjustments to components that control tank pressure. Do not make alterations to factory operating pressure settings. Check operation of safety valve on a regular basis and never operate without a factory approved safety valve.</p>

 <b>DANGER</b>	<p>Serious injury or death may occur if accessories or attachments are operated above the manufacturer's recommended pressure ratings, causing them to explode or fly apart.</p>
	<p>Do not use air tools or attachments before reading operator's manual to determine maximum pressure recommendations. Never exceed manufacturer's allowable pressure ratings. Do not use compressor to inflate small low pressure objects such as toys.</p>

 <b>WARNING</b>	<p>Serious burn injuries could occur from touching exposed metal parts such as compressor head, copper/braided discharge lines, and hydraulic motor during operation and even after compressor is shut down for sometime.</p>
	<p>Never touch any of the exposed metal parts during operation and for an extended period of time after air compressor has shut down. Do not attempt maintenance on the unit until it has been allowed to completely cool.</p>



Yetter Coulter/Row Cleaner Combo

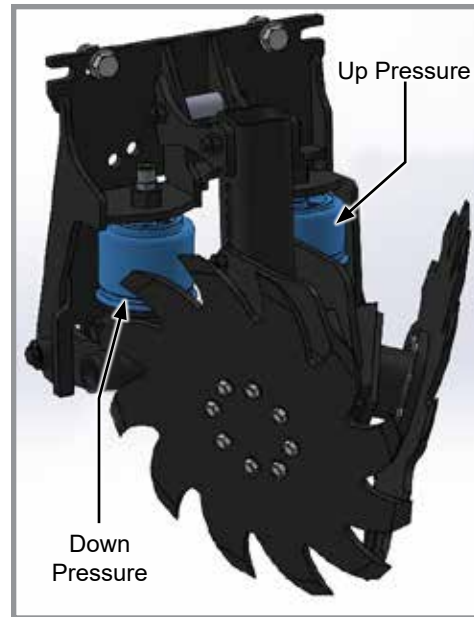

Yetter Row Cleaner

Model	Width	Row Size	Configuration
5700	60'	24	8 Row Center Section (8-8-8)
5700	60'	36	12 Row Center Section (12-12-12)
5700	40'	24	10 Row Center Section (7-10-7)

Wheel track layouts shown below: WT circuit is dictated by where the wing flex happens. Stub wing row units are all on wheel track circuit.

Yetter Residue Manager	
UP (Up Pressure)	3/8" Blue
RD (Wing Down Pressure)	3/8" Black*
WT (Wheel Track Down Pressure)	Brown
Pressure from Tank to Control Box (Supply)	Brown

**24 Row 20"**

UP (Up Pressure) = Blue  
 RD (Wing Down Pressure) = Black  
 WT (Wheel Track Down Pressure) = Brown

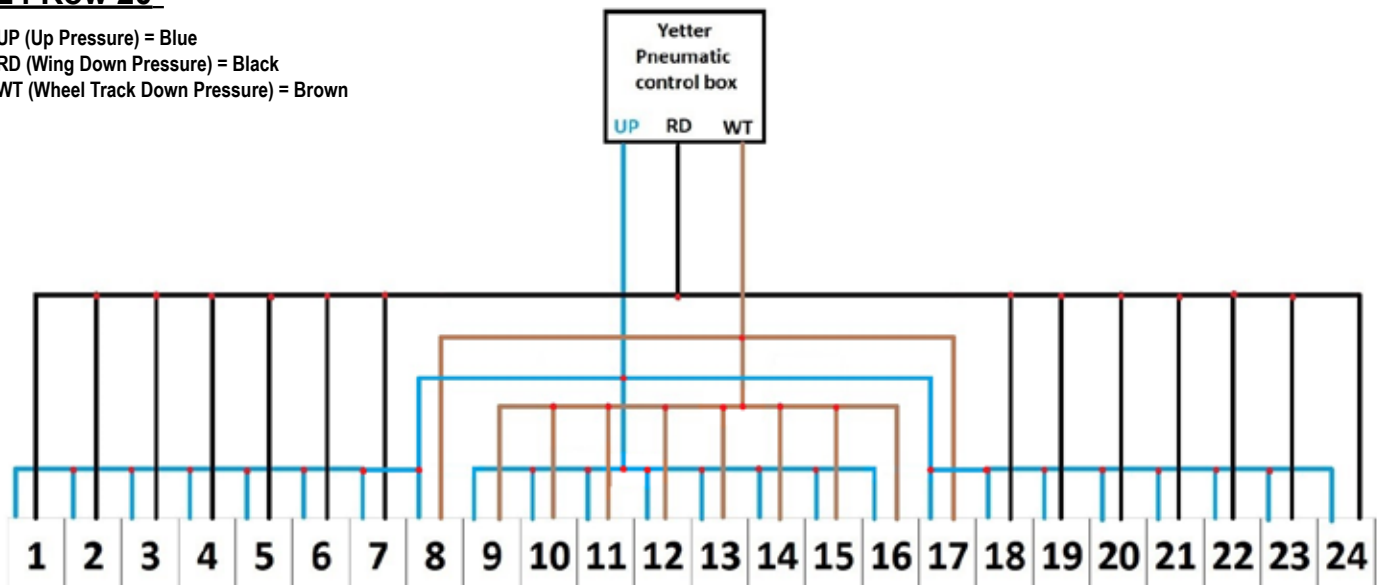

**24 Row 30"**

UP (Up Pressure) = Blue  
RD (Wing Down Pressure) = Black  
WT (Wheel Track Down Pressure) = Brown

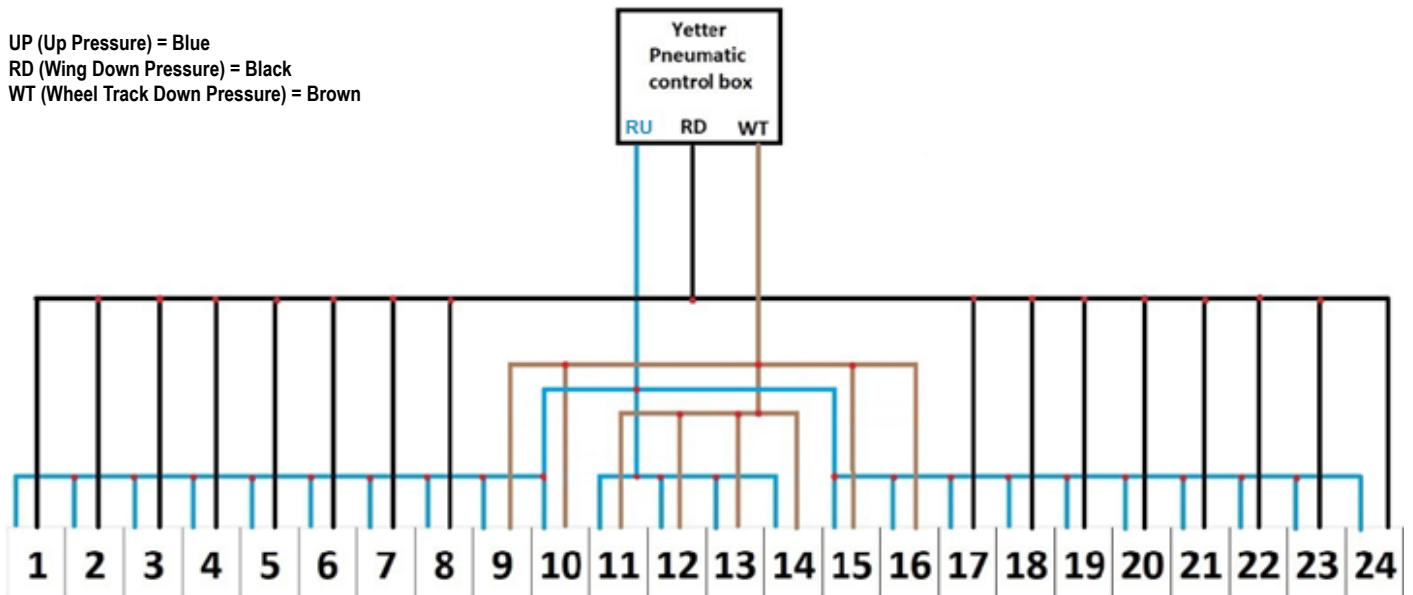

**36 Row 20"**

UP (Up Pressure) = Blue  
RD (Wing Down Pressure) = Black  
WT (Wheel Track Down Pressure) = Brown

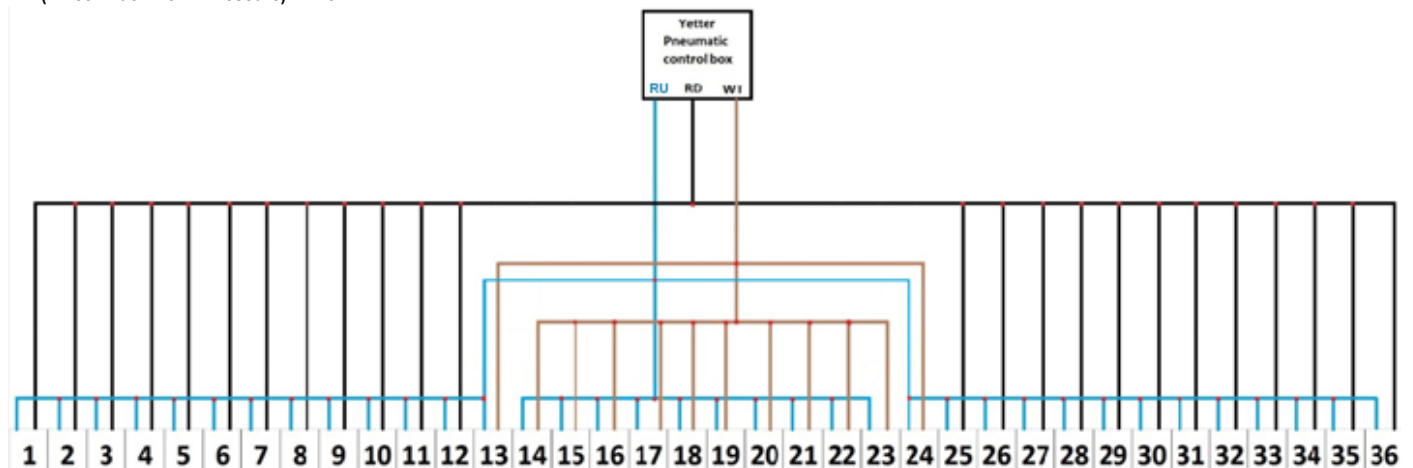

Operation

Failure to properly set the planter frame height and levelness can result in less than successful operation of the planter and the Yetter product. This may result in damaged equipment. All operators should read and thoroughly understand the instructions given prior to using the Yetter residue managers.

**NOTE: DO NOT use this product if the planter is not adjusted properly!**

For proper operation of the planter attachments and row units, it is imperative that the planter toolbars and row unit parallel arms be level side-to-side and front-to-rear. The toolbar frame should operate at a recommended height from the planting surface.

Refer to “Leveling Planter” in the machine operation section of the planter operator’s manual. Always recheck planter after filling with seed and fertilizer to make sure level hasn’t changed with added weight.

---

### System Start Up Procedure

**NOTE: For proper operation, the planter frame must operate level (fore, aft, and side to side) and at the correct height.**

**NOTE: Regularly inspect the residue managers for loose or worn bolts and hardware. Repair or replace as needed.**

System startup procedure should be followed every time the system is turned on. This will ensure that component parts of the system are working correctly. Refer to the Blue Vantage Operator's Manual for display operation.

Begin outside of a planting task to ensure the compressor will build pressure and there are no leaks in the system. If the compressor turns on and the system builds pressure the compressor will shut off at 140-145 psi. If 140-145 psi isn't reached and held while there are no residue manager adjustments being made, there is likely a leak in the system. Check hose connections and walk around planter listening for leaks. Best to do this investigation without vac and bulk fill fans running. When compressor has shut off because it reached the appropriate pressure, select the quick raise preset to apply air to the air bags to raise all of the residue managers. Allow the compressor to refill if it dropped below 120 psi while doing this. This may or may not happen based on the number of rows on your planter. (12 row planter requires less air to make adjustments when compared to a 36 row planter)  
After it is verified all residue managers went up, choose another preset on the Blue Vantage display and watch to ensure all row cleaners were adjusted to a lower height appropriately.

### System Settings

The amount of down/lift pressure will vary greatly across soil types, tillage practices, soil moisture, row unit weight and many other variables. Manage pressure in the down and/or lift circuits in order to maintain 90%+ ground contact while keeping pressure between 20-60 psi.

Typical starting range for residue managers would be 35 psi up, 30 psi down, and 32 psi WT. Typical starting range for residue managers w/coulter combo would be 30 psi up, 35 psi down, and 37 psi WT. Pressure settings can be saved as a preset in the Blue Vantage Display. All of the above information can be edited on the row cleaners tab of the Actions page in the Blue Vantage display.

If the residue managers are not removing enough residue, add down pressure or subtract up pressure. If the residue managers are being too aggressive, subtract down pressure or add up pressure.

Normal operating ranges:

Down Pressure Bags: 20-60 psi

Lift Pressure Bags: 20-60 psi

Tank Pressure: The gauge at the tank will read between 140-145 psi when full. The tank pressure reading on the Blue Vantage display will be around 100-120 psi, depending on what the pressure regulator on the water separator assembly is set at. The tank has two safety relief valves that will automatically exhaust excess pressure in the event that the pressure would exceed 175 psi.

The health screen on the Blue Vantage display will show:

- Pressure supplied to pneumatic control box (psi)
- RU up pressure (psi)
- WT down pressure (psi)
- RD down pressure (psi)
- Compressor status
- Total number of compressor run hours

ROW CLEANER DO'S AND DON'TS

1. DO NOT use as a tillage tool; Residue Managers are designed to move crop residue and to break up clods and crust.
2. DO NOT operate planter at slow speeds. Ground speed affects how aggressive the residue manager wheels are. Operate at sufficient speed (refer to you OEM planter manufacturer manual) to maintain good residue flow.
3. DO NOT expect 100% of crop residue to be cleared, it is not necessary and would necessitate engaging the soil. The width of path cleared depends on ground conditions, depth setting, and ground speed.
4. DO expect to see wheels occasionally quit turning, indicating ideal (shallow) setting which is not moving soil.
5. DO adjust toolbar frame height and drawbar correctly. It is very important to ensure planter opener will follow ground contours properly.
6. DO NOT run air pressure to bags below 20 psi or above 60 psi. Full range of travel can be achieved between these settings.
7. DO grease the hub cavity of the bearings regularly. Even though the bearings are sealed, filling the hub keeps moisture, dirt, and debris from entering the hub and ruining the seal.
8. DO NOT run the coulter blades, if equipped, deeper than the disc opener blades. Coulter should be set to run even or slightly above disc opening blades depth. ["Yetter 2940 Air Adjust Residue Manager" on page 2-35](#) in Row Unit Section for more information.

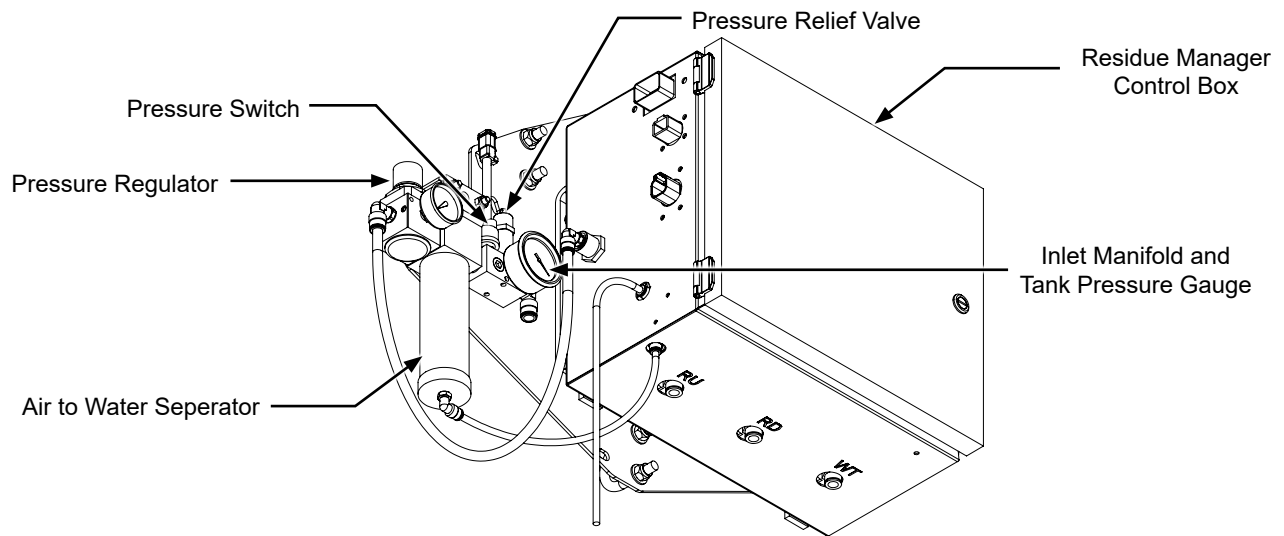

Residue Manger Control Box

**Residue Manger Control Box** - Contains valves that control air pressure delivered to 3 circuits on planter.

**Air to Water Separator** - Removes water from system before air is delivered to control valves in box.

**Inlet Manifold and Tank Pressure Gauge** - Gauge = 140-145 psi tank full, 120 psi when compressor turns back on.

**Pressure Regulator** - Sets pressure that goes into control box, should be set between 100-120 psi.

**Pressure Switch** - Turns on compressor at 120 psi.

**Pressure Relief Valve** - Will discharge air at 175 psi.

Air Compressor

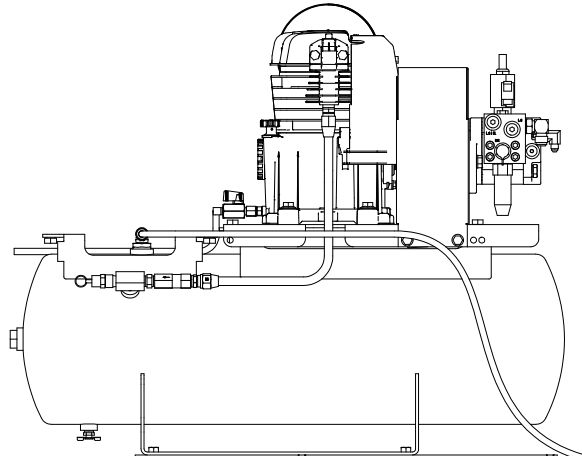

Prior to daily operation check the oil in the compressor when the planter is on level ground. The oil level can be checked in the clear sight glass on the end of the compressor. Always maintain oil level to read 2/3 full on the sight glass. Oil levels over this amount can result in oil blowing past rings or through crankcase breather. Lower amounts of oil can result in insufficient lubrication of moving parts.

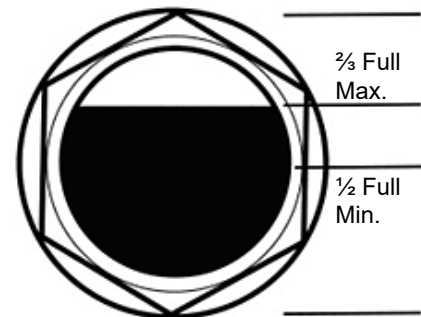

The compressor has a manual over-ride for troubleshooting, to operate manual override pull up on the knurled knob on hydraulic valve to operate compressor.

When tractor is at operating PTO speed, it will flow at 4 gpm that the compressor is set to at the factory. If user continues to pull the knob, pressure will eventually relieve at blow off valve at the end of copper tube assembly going to tank. When knob is released, flow stops and compressor ceases operation.

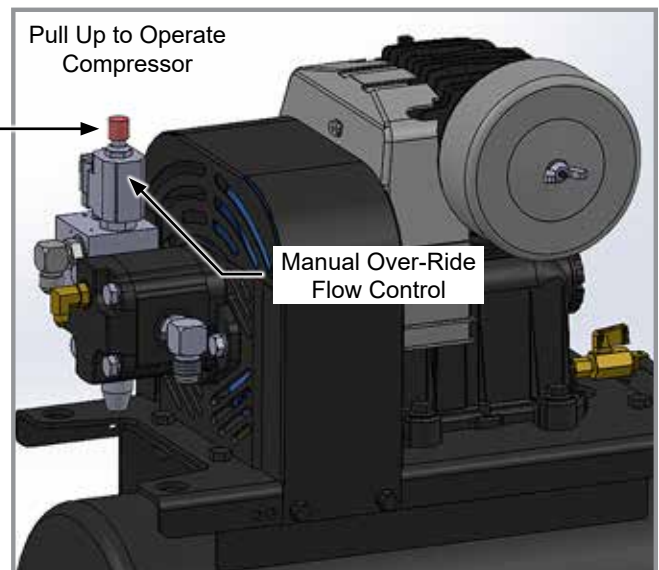

Residue Manager Settings

The default position for the wheel mount arm will be set in the fifth hole from the top.

Heavy tillage conditions - move wheel mount arm up to the 3rd or 4th hole.

No-till conditions - Move wheel mount arm down to the 6th or 7th hole from the top.

Residue manager wheels should lift completely out of the ground but also be 50% of travel with desired setting for each specific field condition. Wheel mount will be higher in tilled conditions and lower in harder no-till conditions.

To adjust position, 9/16 sockets/wrenches are required. Hardware should be tightened so there is no motion between wheel mount arm and adjustment tube.

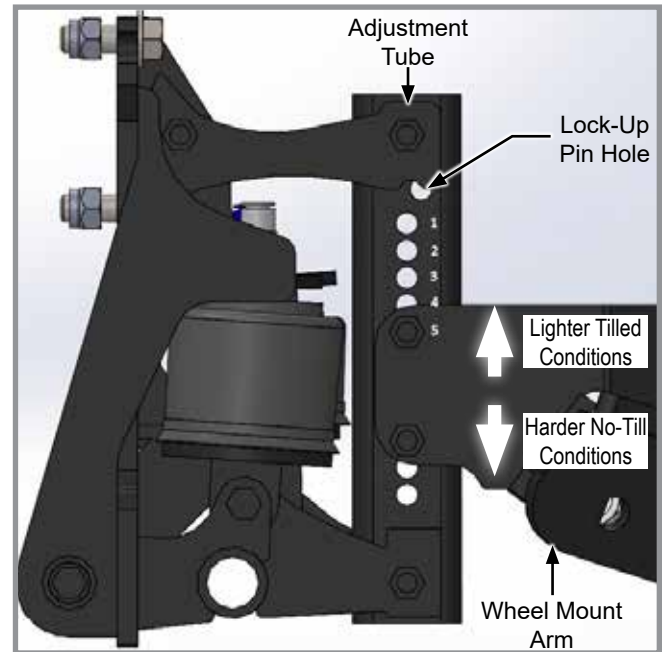

Coulter Combo Settings

Maintain a gap between the bottom of no-till coulter and bottom of opener blades.

If no-till coulters are deeper than opener blades, adjustments are necessary.

Check dimension while planter is down on a level concrete floor, 1/8" - 1/4" spacing needs to be maintained between bottom of no till coulter and bottom of opener blades. As blades wear recheck spacing. Replace blades as needed.

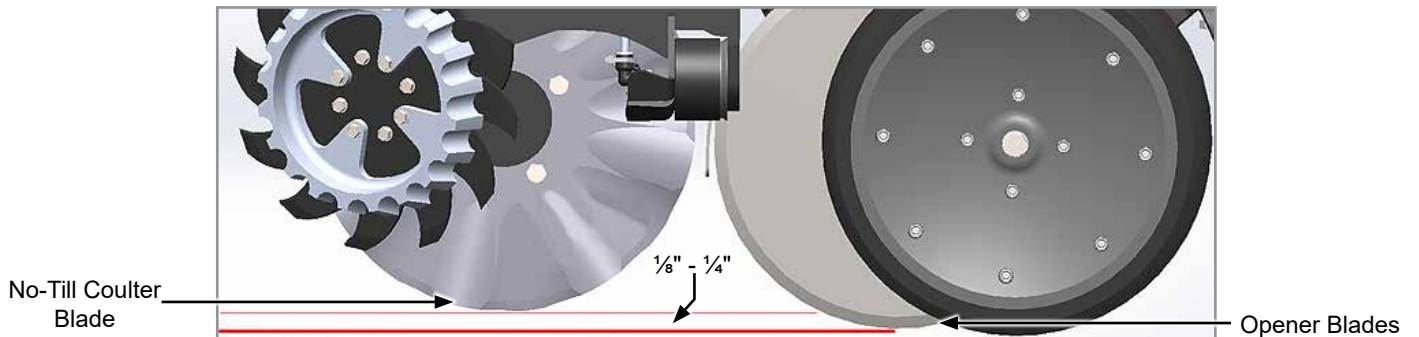

Adjust position of no-till coulter, loosen the nut and move coulter vertically to proper location.

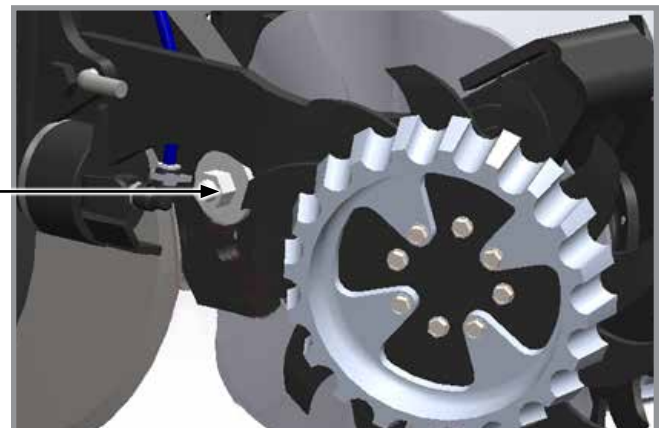

**This page intentionally left blank.**

## PLANTING DEPTH

Planting depth is maintained by adjustable row unit gauge wheels. Depth adjustment range is approximately 1/2" to 3 1/2".

1. Raise planter to remove weight from wheels.
2. Push down on depth adjustment handle and reposition it forward to decrease or rearward to increase planting depth. Initially adjust all units to the same setting.
3. Lower planter and check operation and planting depth of all row units. Readjust individual rows as needed for uniform operation.



## CLOSING WHEEL GENERAL ADJUSTMENTS

Eccentric bushings in the wheel arm stop allow for lateral adjustment of the "V" closing wheel assembly. Use a 3/4" wrench to loosen hardware attaching closing wheel arm to wheel arm stop. Use another 3/4" wrench to turn eccentric bushings until **closing wheels are aligned with seed trench**. Tighten hardware.

Closing wheels can be installed "offset" (to improve residue flow) or "directly" opposite. Use forward installation holes if set "directly" opposite.

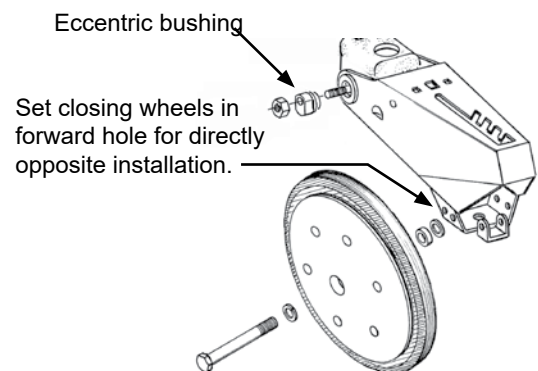

### Spiked Closing Wheel

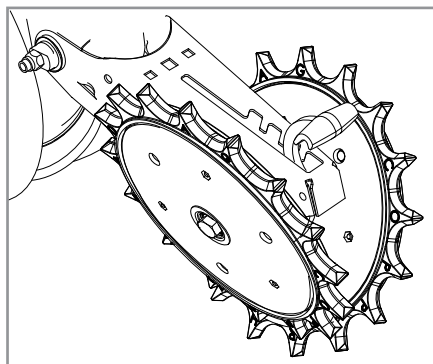

**Spiked Closing Wheel**



Spiked closing wheels crumble the sidewall, allowing roots to penetrate soil. They can be used on pull row units and push row units.

Align spiked closing wheels straight across from each other, in most forward holes on closing wheel arm. Set the wheels 1" - 1 1/4" (2.5 - 3.1 cm) apart at the closest point.

## AIR ADJUST CLOSING WHEEL ARM (PCW)

Adjust closing wheels from the cab for optimum seed-to-soil contact using Blue Vantage-controlled, air-adjustable closing wheels. Refer to your Blue Vantage Operator Manual for more information.

Air Adjust Closing Wheels	
Function	Hose Color
PCW Center Section Main Trunk	White
PCW Wing Section Main Trunk	Gray

### **NOTICE**

When inflating air bags, ensure the airbags are not folded. If a bag is folded, reduce air pressure to 25 psi and straighten out bag. If bag runs folded, this will reduce the performance life of the air bag.

### PDP AND AIR CLOSING WHEEL SCHEMATICS

24 Row 20"  
Air Closing Control Valves  
PCW Wing (Gray)  
PCW Center (White)

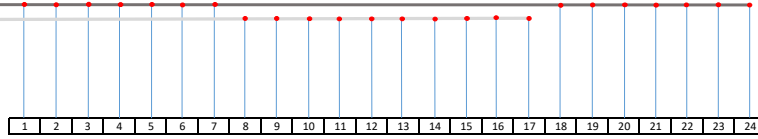

24 Row 30"  
Air Closing Control Valves  
PCW Wing (Gray)  
PCW Center (White)

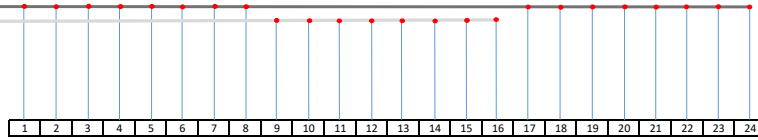

36 Row 20"  
Air Closing Control Valves  
PCW Wing (Gray)  
PCW Center (White)

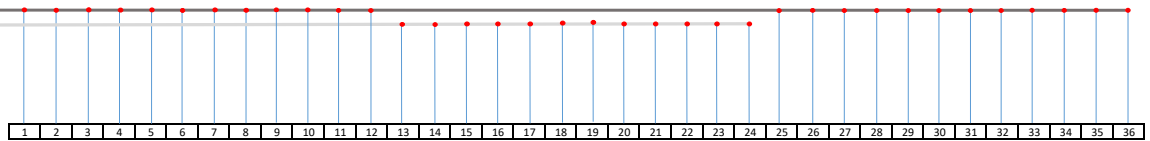

PDP Control Valves  
PDP (Purple)



PDP Control Valves  
PDP (Purple)

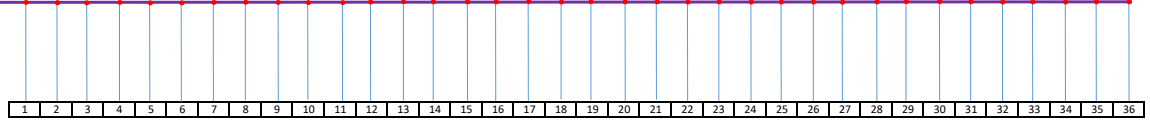

## ROW UNIT MOUNTED NO TILL COULTER

Row unit mounted no till coulters may be used on row units.

Coulter blade can be adjusted to one of four ½" incremental settings in the forked arm. Initial location is the top hole.

Move blade as it wears to one of the three lower holes to maintain coulters at or slightly above opener discs. Adjust coulters below depth of double disc opener blades in very hard soil conditions such as compacted wheel tracks to improve opener penetration and cutting of surface residue.

Check operating depth by setting planter down on a level concrete floor and checking relationship between coulters and row unit opener blade. Make sure planter is level and coulters are square with planter frame and aligned with row unit disc opener.

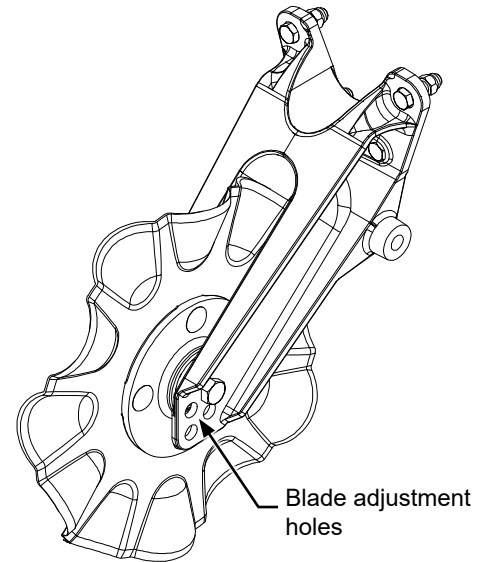

Row Unit Mounted No Till Coulters

**NOTE:** Torque 5/8" spindle hardware to 120 ft-lb (162.7 N-m).

## COULTER MOUNTED RESIDUE WHEELS W/TREADER

Coulter mounted residue wheels are designed for use on pull row units and push row units. Row unit extension brackets are required on the four center pull row units if the planter is equipped with coulters mounted residue wheels.

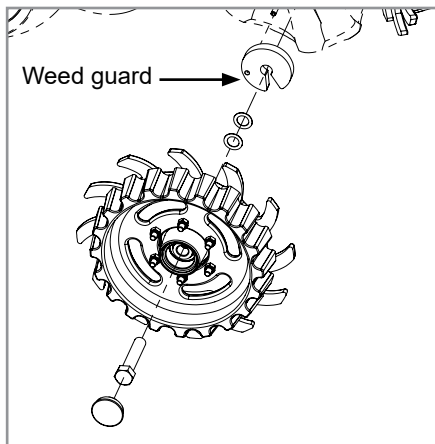

**NOTE:** Opening in weed guard must face down.

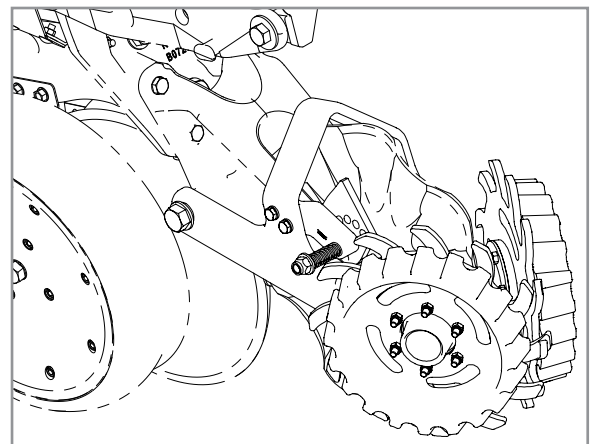

Residue wheels attach to row unit mounted coulters with two cap screws and sleeves allowing unit to free-float. A 2-position spindle bolt mounting positions wheels interlocked or staggered. Depth adjustment is made with a spring-loaded cam and pin with 8 positions in 7/16" (6 mm) increments. A high point on the cam allows wheels to be locked up.

A weed guard on the inboard side of each wheel helps prevent weed wrap which can cause premature bearing failure.



**PNEUMATIC DOWN PRESSURE (PDP)**

Row unit down pressure can be adjusted on-the-go as field conditions change. Blue Vantage monitor adjusts pressure.

Hose Function Chart	
Function	Hose Color
<i>Pneumatic Down Pressure</i>	
PDP Main Trunk	Purple
*Fertilizer system also uses 3/8" black tubing.	

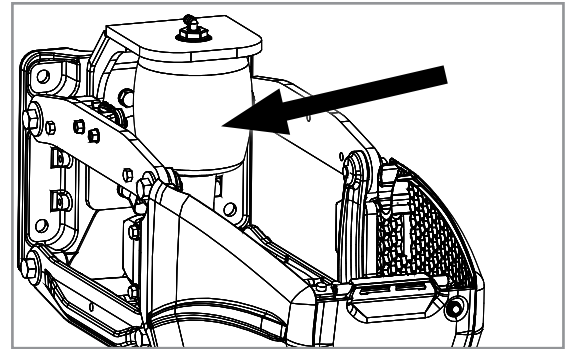

**Row Unit Air Spring**

Electric Air Compressor: If equipped with an electric air compressor, tank pressure will be limited to 120 psi through compressor limit switch.

**NOTE:** Air tank can be prefilled using the valve stem. **DO NOT** prefill above 120 psi. This is not applicable if Yetter is installed.

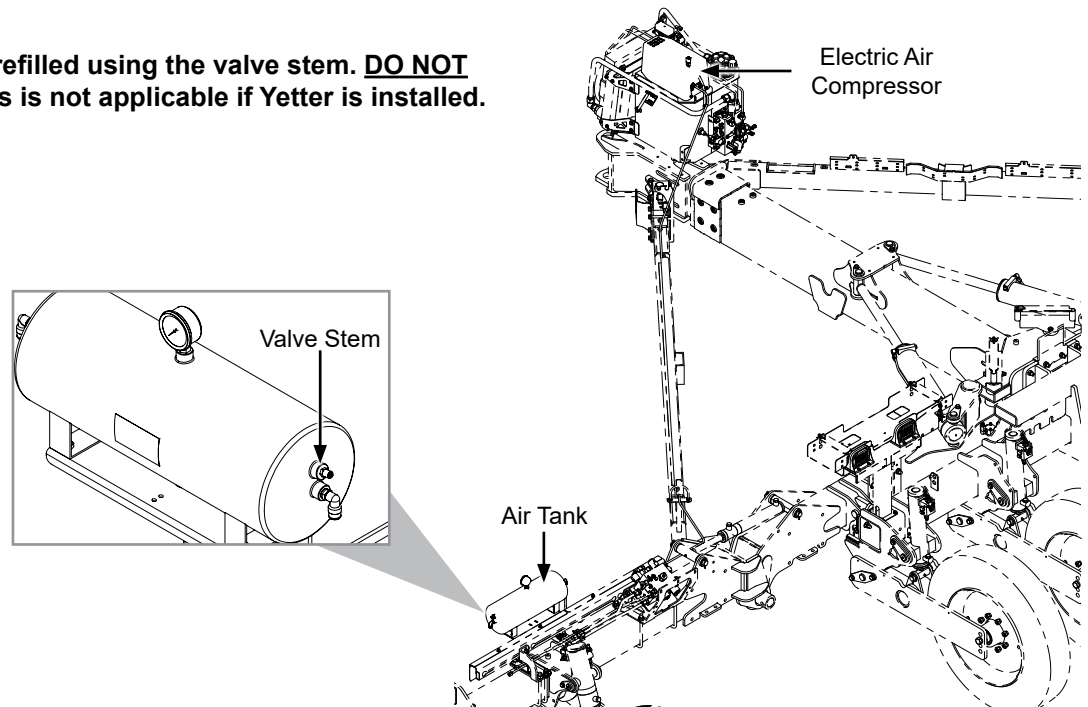

**Electric Air Compressor**

Hydraulic Compressor: If equipped with a hydraulic compressor, tank pressure will be as high as 140 psi. An additional regulator is included to reduce pressure to air control valves for PDP as well as air adjust closing wheels (PCW) if equipped. This regulator should be set to 110-120 psi max.

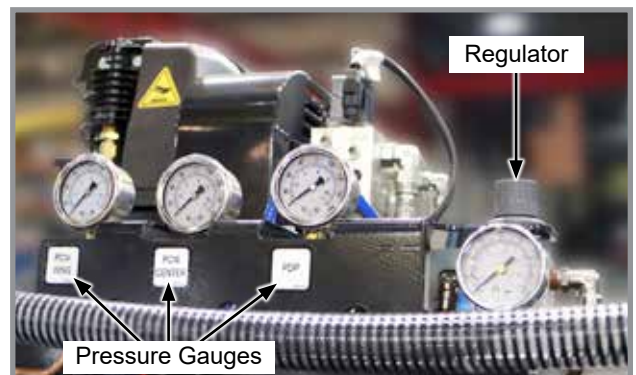

**Hydraulic Compressor (16 Row Shown)**

---

## FIELD OPERATION

**NOTE:** Adjust down pressure with planter lowered and row openers in ground for most accurate adjustment. Pressure can be adjusted using your Blue Vantage monitor. Refer to the Blue Vantage manual for more information.



### ADJUST DOWN PRESSURE FROM CAB

Use the monitor to adjust down pressure. Refer to your Blue Vantage manual for more information.

Refer to M0288 - Kinze Blue Vantage Operator's Manual for pressure adjustment with Blue Vantage.

## TRUE DEPTH

True Depth provides on demand row by row hydraulic row unit down force ranging from 150 lbs. up force to 650 lbs. down force at 2350 psi.



True Depth

## SEED HOPPERS

Seed hoppers have a capacity option of 0.8 bushels (True Rate) or 0.9 bushels (True Speed).

Use clean seed and make certain there are no foreign objects inside when filling seed hopper. **Place hopper lids on hoppers after filling to prevent accumulation of dust or dirt in seed meter which can cause premature wear.**

Periodically empty hoppers completely to remove any foreign objects and to ensure proper seed meter operation.

Disengage hopper latch and lift hopper off hopper support. Disconnect vacuum meter and drive connections.

### To remove hopper:

1. Unlock each side of hopper.
2. Unlock rear of hopper.
3. Lift vertically off hopper support.

### To install hopper:

1. Align hopper onto hopper support.
2. Lock rear of hopper.
3. Lock each side of hopper.

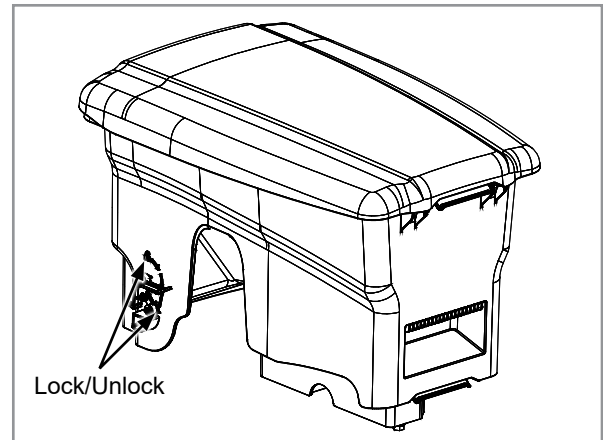









**Seed Hopper**

## MANUAL RUN BUTTON (BLUE DRIVE)







Use the manual run button to turn on the seed meter and all optional equipment on each row unit to check functionality.

## TRUE RATE SETTINGS

Crop		**Seed Disc Kit	Seed Disc Part No.	Ejector Wheel (Color)	Cells	Seed Size Range	Singulator Zone Setting	Vacuum Setting Inches of Water (kPa)	Lubricant
	Corn ‡ Large Sweet Corn	G11152X	B1219 (Light Blue)	1 row 6 punches (Light Blue)	40	35-70 lbs/80k (2500-5000 seeds/kg)	2	18-20 (4.5-5.0)	<b>Graphite* Talc*</b> Bayer Fluency† (if mandated)
	Soybean	G11047X	B1232 (Black)	2 rows 8 punches (Black)	120	2200-4000 seeds/lb (4850-8820 seeds/kg)	0	10-14 (2.5-3.5)	<b>Graphite* Talc*</b> Bayer Fluency† (if mandated)
	Soybean	G11048X	B1238 (Black)	1 row 9 punches (Black)	60	2200-4000 seeds/lb (4850-8820 seeds/kg)	0	10-14 (2.5-3.5)	<b>Graphite* Talc*</b> Bayer Fluency† (if mandated)
	Sugar Beet	G11154X	B1229 (Dark Orange)	1 row 9 punches (Dark Orange)	60	Pelletized	2	15 (3.75)	<b>Graphite* Talc*</b> Bayer Fluency† (if mandated)
	Milo	G11154X	B1229 (Dark Orange)	1 row 9 punches (Dark Orange)	60	10,000-20,000 seeds/lb (22000-44000 seeds/kg)	2	15 (3.75)	<b>Graphite* Talc*</b> Bayer Fluency† (if mandated)
	Sunflower ‡ Small Sweet Corn	G11153X	B1230 (Gray)	1 row 6 punches (Gray)	40	Oil seeds #2, 3, 4	2	12-18 (3.0-4.5)	<b>Graphite* Talc*</b> Bayer Fluency† (if mandated)
	Sunflower	G11153X	B1230 (Gray)	1 row 6 punches (Gray)	40	Oil seeds #5	2	5-8 (1.25-2.0)	<b>Graphite* Talc*</b> Bayer Fluency† (if mandated)
	Specialty Disc 1	G11105X	B1233 (Green)	1 row 6 punches (Green)	60	Cotton	2	15-20 (3.75-5.0)	<b>Graphite* Talc as needed*</b> Bayer Fluency† (if mandated)

Continued on next page.

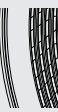
**TRUE RATE SETTINGS**

Crop	**Seed Disc Kit	Seed Disc Part No.	Ejector Wheel (Color)	Cells	Seed Size Range	Singulator Zone Setting	Vacuum Setting Inches of Water (kPa)	Lubricant
 Specialty Disc 2	G11106X	B1235 (Brown)	1 row 6 punches (Green)	60	Black turtle & navy edible beans	2	15-20 (3.75-5.0)	<b>Graphite* Talc as needed*</b> Bayer Fluency <sup>†</sup> (if mandated)
 Specialty Disc 3	G11107X	B1234 (Dark Blue)	1 row 6 punches (Green)	60	Pinto & Great Northern edible beans & low-rate soybean	2	15-20 (3.75-5.0)	<b>Graphite* Talc as needed*</b> Bayer Fluency <sup>†</sup> (if mandated)
 Wheat Disc	G11042X	B1236 (Purple)	Brush Type	54	N/A Volumetric	0	6-16 (15-41)	<b>Graphite* Talc as needed*</b> Bayer Fluency <sup>†</sup> (if mandated)
 Wheat Disc	G11332X	10783001 (Red)	3 rows 9 punches (Red)	231	8,000-20,000 seeds/lb (17,600-44,000 seeds/kg)	§N/A	15-24	<b>Graphite* Talc as needed*</b> Bayer Fluency <sup>†</sup> (if mandated)

Install selected seed disc. Position vacuum cover on meter by aligning keyhole slots over bolt heads. Push cover on meter and turn counter clockwise to lock in place.

\*For More information on application rate, see ["Additives" on page 3-32](#).

\*\*Includes seed disc, ejector wheel, and spring.

<sup>†</sup>Bayer Fluency Agent is only required to be used in place of graphite or talc lubricants on vacuum equipped planters that are sowing neonicotinoid treated seeds in Canada. Refer to ["Bayer Fluency Agent" on page 3-33](#) for more information.

‡Conventional hoppers only, not applicable with bulk fill.

§Wheat disc wiper must be installed, refer to ["Wheat Disc Wiper Installation" on page 3-17](#)

**NOTE:** See ["Field Check Seed Population" on page 2-32](#) for more information. Always field check seed population to ensure planting rates are correct.

**NOTE:** Singulator settings are marked from 0 - 3.

**NOTE:** Mixing seed sizes and shapes affects meter performance. Use consistent seed size and shape.

**NOTE:** Use 1 tablespoon powdered graphite with each standard hopper fill of seed. Seed treatment, foreign material, dirt or seed chaff may cause gradual reduction of seed disc fill (population). See "Additives" pages for more information.

**NOTE:** Excessive seed treatment, humidity, and light-weight seed can affect meter performance. Use ½ cup of talc with each standard hopper fill of seed and mix thoroughly to coat all seeds and adjust rates as needed. Use of talc aids seed flow into meter, singulation, and disc seed drop.

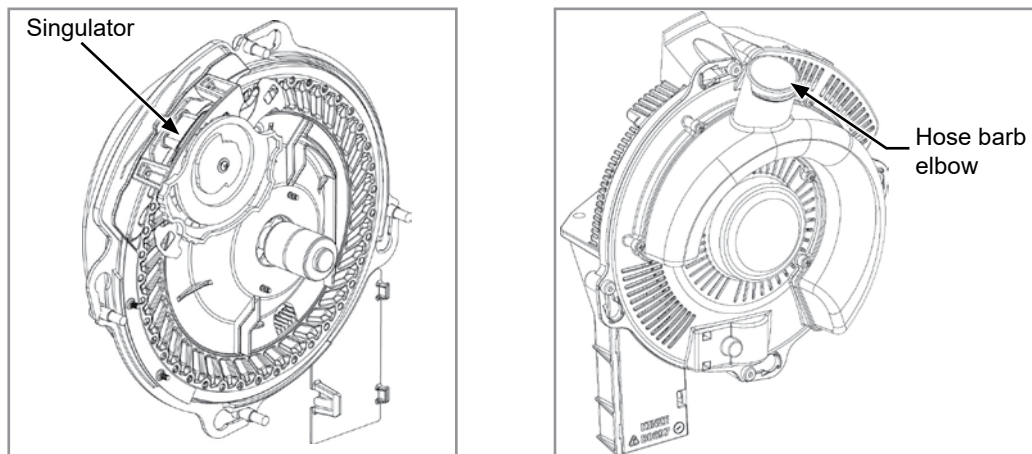

**NOTE:** Foreign material in seed disc orifices, such as seed chips, hulls, stems, etc., may affect seed delivery. Clean seed ensures accurate seed metering from vacuum seed meter. Remove Seed discs daily to check for buildup of foreign material in seed disc orifices.

Air inlet screens allow air to enter system and aids in keeping field residue or other foreign material out of meter.

See ["True Rate Meter Maintenance" on page 5-12](#) and ["Preparation for Storage" on page 5-38](#) in Lubrication and Maintenance section for more information.

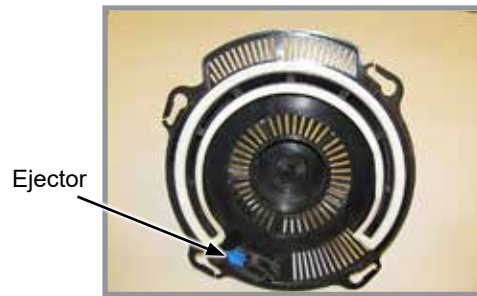

**NOTE: Damaged seed or seed containing foreign material will cause plugging of seed disc orifices and require more frequent seed meter cleanout to prevent underplanting.**

#### Wheel-Type Ejectors

Wheel-type ejectors expel seed remnants from seed disc orifices. These ejectors are disc specific and colored coded to match disc.

### **NOTICE**

Replace hopper lids after hoppers are filled to prevent accumulation of dust or dirt in seed meter which will cause premature wear.

**NOTE: Seed size, seed shape, seed treatments, travel speed, and planting rate affect meter performance.**

1. Select seed disc and ejector to match crop and population.

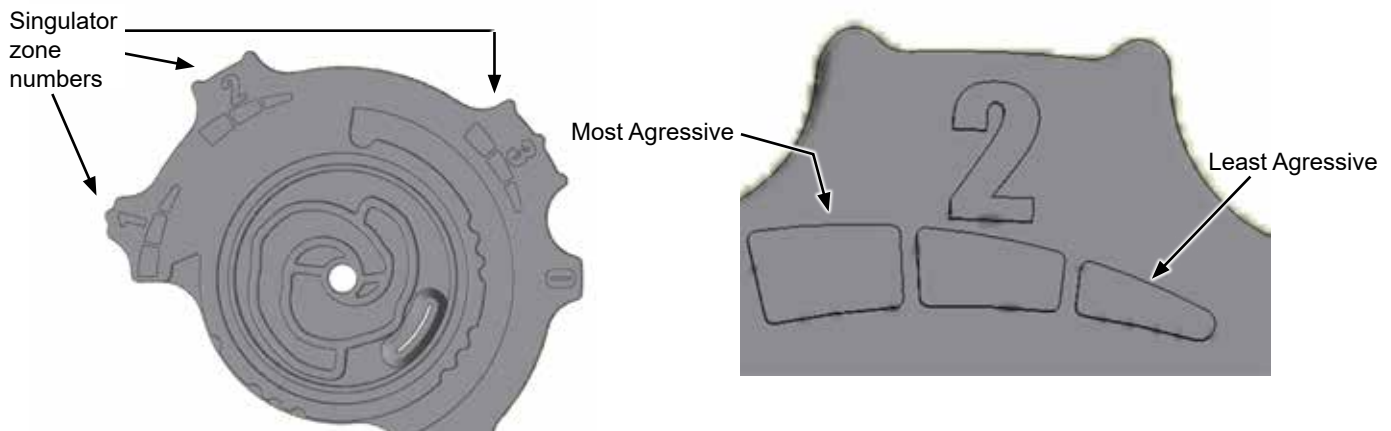

**Singulator Adjustment Wheel**

2. Adjust singulator wheel to initial setting. Seed size, seed shape, seed treatments, travel speed and planting rate all affect meter performance.
3. With vacuum fan running, use priming sequence on Blue Vantage display to load seed into seed disc cells.
4. Adjust vacuum level to initial setting according to tables on page.

**NOTE: Vacuum reading will be much lower when seed disc cells are empty. Load all seed cells before setting vacuum level.**

**NOTE: Operate vacuum fan 3-5 minutes to bring oil up to normal operating temperature prior to making final vacuum level adjustment.**



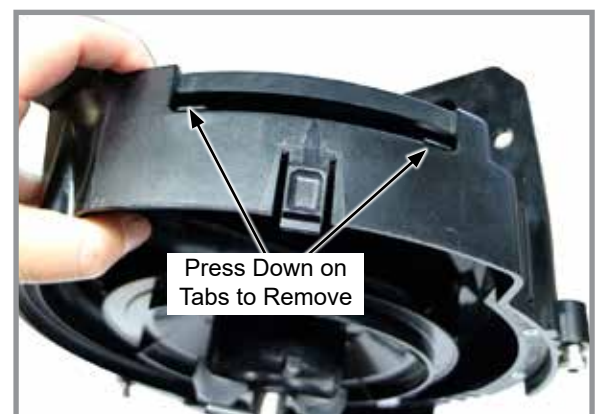

## WHEAT DISC WIPER INSTALLATION

1. Disengage seed drive and remove seed hopper and meter.
2. Rotate seed disc hub clockwise to unlock and remove seed disc.
3. Remove singulator.
4. Install wheat brush singulator in place of original singulator.
5. Reinstall seed disc.
6. To remove wheat brush singulator press on tabs to release.



**TRUE SPEED METER SETTINGS**

Crop - Seed Disc Part No. - ‡Seed Disc Kit	Ejector Wheel (color)	Baffle Setting	Seed Size Range	Population	Singulator Installed	Vacuum Setting Inches of Water	Lubricant
 <b>Corn, 32 Cell</b> (Light Blue) - P/N: G10347701 - Kit: 10892X	1 row 6 punches (Blue)	1	1140-2280 seeds/lb	15-40K sds/acre	Yes	*12 to 20 (See <a href="#">"Row Unit Operation" on page 3-1</a> )	Graphite† Talc† Bayer Fluency§ (If mandated)
 <b>Soybean, 46 Cell</b> (Black) - P/N: G10369101 - Kit: 10894X	1 row 8 punches (Black)	3	2200-4000 seeds/lb	All 15" and 20" Rows up to 130k sds/acre	No	*15 to 25 (See <a href="#">"Row Unit Operation" on page 3-1</a> )	Graphite† Talc† Bayer Fluency§ (If mandated)
 <b>Soybean, 92 Cell</b> (Black) - P/N: G10369001 - Kit: 10893X	2 rows 8 punches (Black)	3-5	2200-4000 seeds/lb	All 30" Rows 20" above 130k sds/ acre	No	*15 to 25 (See <a href="#">"Row Unit Operation" on page 3-1</a> )	Graphite† Talc† Bayer Fluency§ (If mandated)
 <b>Cotton, 46 Cell</b> (Green) - P/N: G10407701 - Kit: 10992X	1 row 8 punches (Green)	1	4000-6500 seeds/lb	20-75k	Yes	8-18 (See <a href="#">"Row Unit Operation" on page 3-1</a> )	Graphite† Talc† Bayer Fluency§ (If mandated)
 <b>Sugar Beets/Milo,</b> 46 Cell (Orange) - P/N: GB1303 - Kit: 10860X	1 row 8 punches (Orange)	1 Use Part Number G10407001 (Orange Door)	Milo: 10k-18k seeds/lb	20-100k	Yes	Milo: 12	Graphite† Talc† Bayer Fluency§ (If mandated)
			Sugarbeets: Pelletized			Sugarbeets: 15	
 <b>Sunflower, 23 Cell</b> (Yellow) - P/N: G10761701 - Kit: 11124X	1 row 8 punches (Yellow)	1	Oil # 2, 3, 4	12K-35K	Yes	#2: 20-30	Graphite† Talc† Bayer Fluency§ (If mandated)
						#3: 15-25	
						#4: 10-??	

Install selected seed disc and ejector.

\*Use low vacuum for small seeds/slow speed and high vacuum for big seeds/high speed.

†For more information on application rate, see Additives section.

‡Includes seed disc and ejector wheel.

§Bayer Fluency Agent is only required to be used in place of graphite or talc lubricants on vacuum equipped planters that are sowing neonicotinoid rated seeds in Canada. Refer to the Bayer Fluency Agent section for more information.

Continued on Next Page.

**NOTE:** See “Field Check Seed Population” on page --- for more information. Always field check seed population to ensure planting rates are correct.

**NOTE:** Baffle settings are marked from 1 – 5.

**NOTE:** Mixing seed sizes and shapes affects meter performance. Use consistent seed size and shape.

**NOTE:** Seed treatment, foreign material, dirt or seed chaff may cause gradual reduction of seed disc fill (population). See “Additives” pages for more information.

**NOTE:** Excessive seed treatment, humidity, and light-weight seed can affect meter performance. Use ½ cup of talc with each standard hopper fill of seed and mix thoroughly to coat all seeds and adjust rates as needed. Use of talc aids seed flow into meter, singulation and disc seed drop.

**NOTE:** Foreign material in seed disc orifices, such as seed chips, hulls, stems, etc., may affect seed delivery. Clean seed ensures accurate seed metering from vacuum seed meter. Remove Seed discs daily to check for buildup of foreign material in seed disc orifices.

See ["True Speed Seed Meter Maintenance" on page 5-14](#) and ["True Speed Seed Meter Cleanout" on page 5-15](#) in Lubrication and Maintenance section for more information.

**TRUE SPEED VACUUM SETTINGS CHARTS**

**NOTE:** Vacuum charts are a recommendation to help select the starting vacuum setting for a particular seed size and target planting speed. Due to variation in seed size, seed shape, and planting conditions, it is likely that additional adjustments in the vacuum setting may be necessary. Decrease vacuum from the listed setting if doubles or high population are displayed and increase vacuum if skips or low population are displayed.

**Recommended Vac Chart for Corn Flat Seed Types**

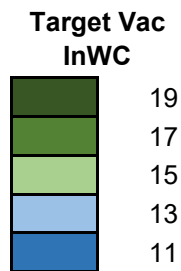
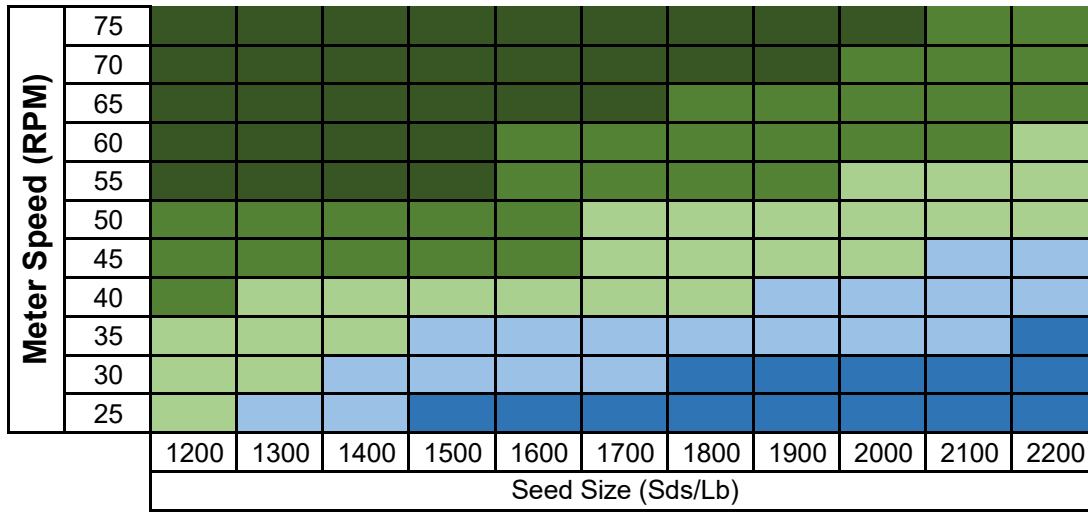

**Recommended Vac Chart for Corn Round Seed Types**

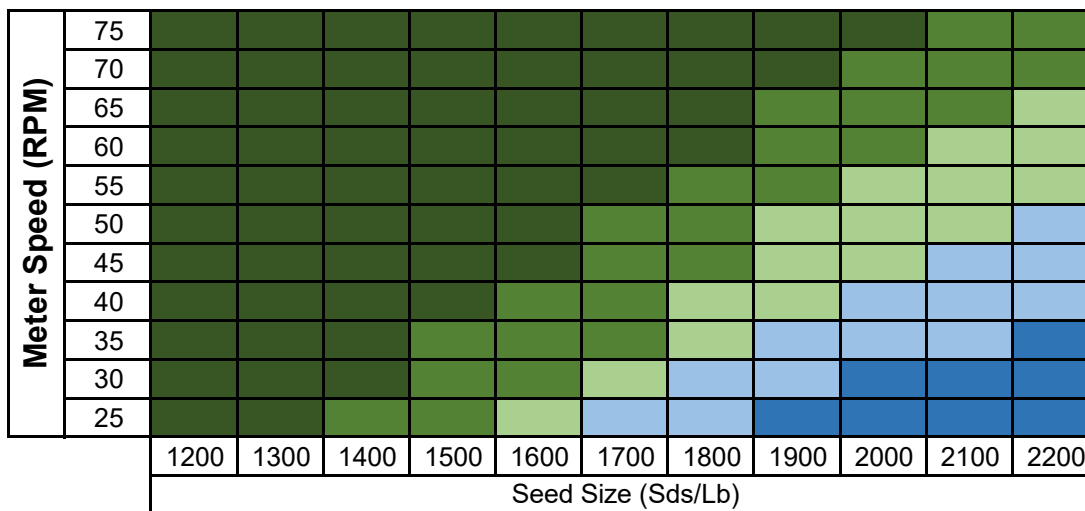

**Recommended Vac Chart for Soybeans (Single Row and Dual Row)**

<b>Meter Speed (RPM)</b>	95															
	90															
	85															
	80															
	75															
	70															
	65															
	60															
	55															
	50															
	45															
	40															
		2300	2350	2400	2450	2500	2550	2600	2650	2700	2750	2800	2850	2900	2950	3000
		Seed Size (Sds/Lb)														

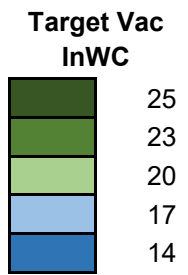

### Recommended Vac Setting for Cotton

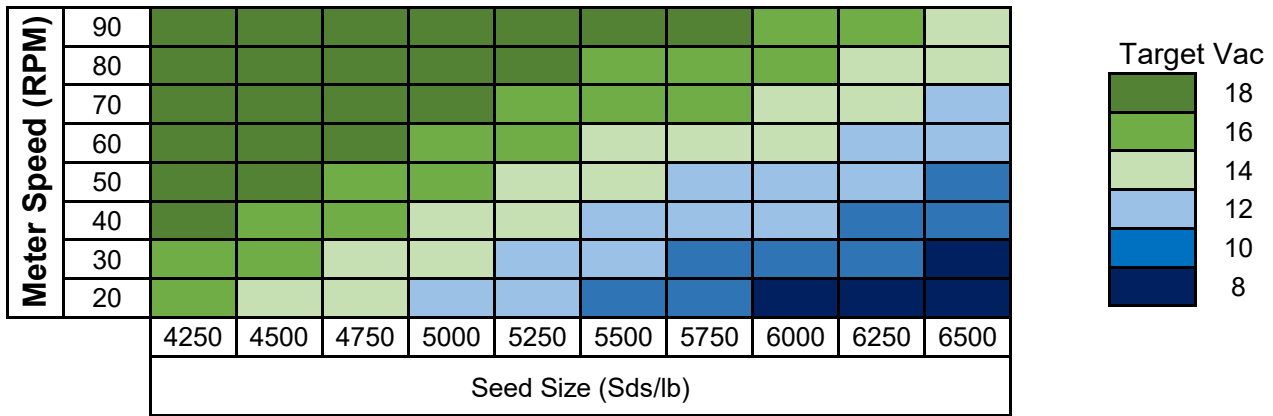

### Recommended Vac Chart for Oil Sunflowers

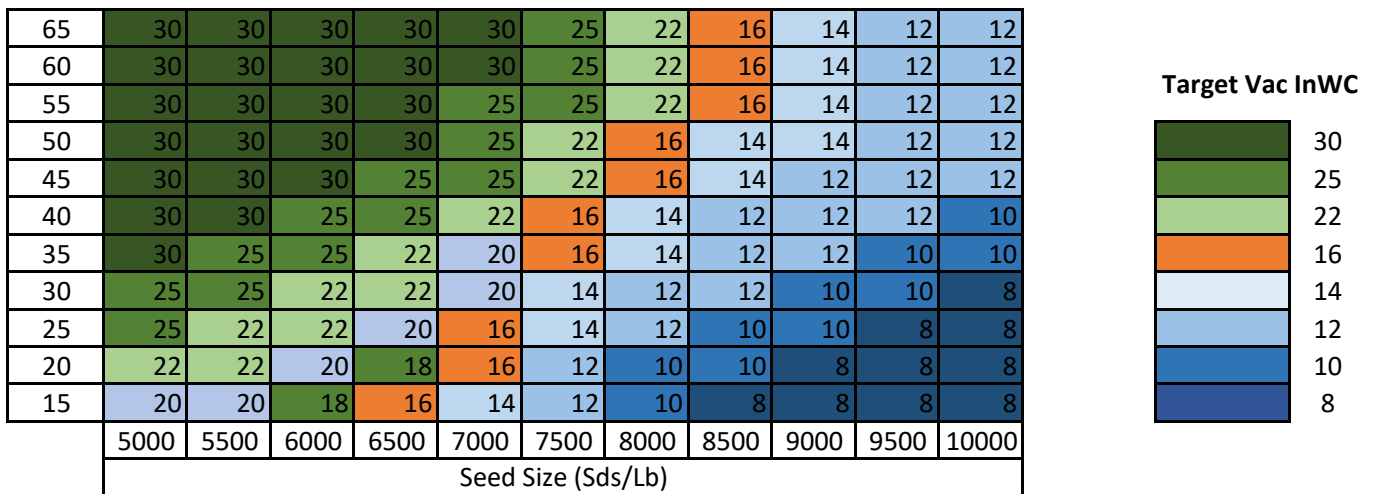

Meter Speed (20" Row Spacing 32 Cell Disc- Corn)

		Ground Speed (mph)										
		2	3	4	5	6	7	8	9	10	11	12
Population Setpoint (sds/ac.)	24000	5	8	10	13	15	18	20	23	25	28	30
	26000	5	8	11	14	16	19	22	25	27	30	33
	28000	6	9	12	15	18	21	24	27	29	32	35
	30000	6	9	13	16	19	22	25	28	32	35	38
	32000	7	10	13	17	20	24	27	30	34	37	40
	34000	7	11	14	18	21	25	29	32	36	39	43
	36000	8	11	15	19	23	27	30	34	38	42	45
	38000	8	12	16	20	24	28	32	36	40	44	48
	40000	8	13	17	21	25	29	34	38	42	46	51
	42000	9	13	18	22	27	31	35	40	44	49	53
	44000	9	14	19	23	28	32	37	42	46	51	56
	46000	10	15	19	24	29	34	39	44	48	53	58
	48000	10	15	20	25	30	35	40	45	51	56	61
50000	11	16	21	26	32	37	42	47	53	58	63	

Meter Speed (30" Row Spacing 32 Cell Disc- Corn)

		Ground Speed (mph)										
		2	3	4	5	6	7	8	9	10	11	12
Population Setpoint (sds/ac.)	24000	8	11	15	19	23	27	30	34	38	42	45
	26000	8	12	16	21	25	29	33	37	41	45	49
	28000	9	13	18	22	27	31	35	40	44	49	53
	30000	9	14	19	24	28	33	38	43	47	52	57
	32000	10	15	20	25	30	35	40	45	51	56	61
	34000	11	16	21	27	32	38	43	48	54	59	64
	36000	11	17	23	28	34	40	45	51	57	63	68
	38000	12	18	24	30	36	42	48	54	60	66	72
	40000	13	19	25	32	38	44	51	57	63	69	76
	42000	13	20	27	33	40	46	53	60	66	73	80
	44000	14	21	28	35	42	49	56	63	69	76	83
	46000	15	22	29	36	44	51	58	65	73	80	87
	48000	15	23	30	38	45	53	61	68	76	83	91
50000	16	24	32	39	47	55	63	71	79	87	95	

	Optimal Zone
	Low or high meter speed, may require vacuum adjustment
	Exceeding maximum meter speed, expect performance degradation

Meter Speed (20" Row Spacing 92 Cell Disc - Soybean)

		Target Ground Speed (mph)										
		2	3	4	5	6	7	8	9	10	11	12
Target Population (sds/ac)	80000	6	9	12	15	18	20	23	26	29	32	35
	85000	6	9	12	16	19	22	25	28	31	34	37
	90000	7	10	13	16	20	23	26	30	33	36	40
	95000	7	10	14	17	21	24	28	31	35	38	42
	100000	7	11	15	18	22	26	29	33	37	40	44
	105000	8	12	15	19	23	27	31	35	38	42	46
	110000	8	12	16	20	24	28	32	36	40	44	48
	115000	8	13	17	21	25	29	34	38	42	46	51
	120000	9	13	18	22	26	31	35	40	44	48	53
	125000	9	14	18	23	27	32	37	41	46	50	55
	130000	10	14	19	24	29	33	38	43	48	52	57
	135000	10	15	20	25	30	35	40	44	49	54	59
	140000	10	15	20	26	31	36	41	46	51	56	61
	145000	11	16	21	27	32	37	42	48	53	58	64
	150000	11	16	22	27	33	38	44	49	55	60	66
	155000	11	17	23	28	34	40	45	51	57	62	68
	160000	12	18	23	29	35	41	47	53	59	64	70
	165000	12	18	24	30	36	42	48	54	60	66	72
170000	12	19	25	31	37	44	50	56	62	68	75	
175000	13	19	26	32	38	45	51	58	64	70	77	
180000	13	20	26	33	40	46	53	59	66	72	79	

	Optimal Zone
	Low or high meter speed, may require vacuum adjustment
	Exceeding maximum meter speed, expect performance degradation



Meter Speed (30" Row Spacing 92 Cell Disc - Soybean )

		Target Ground Speed (mph)										
		2	3	4	5	6	7	8	9	10	11	12
Target Population (sds/ac)	80000	9	13	18	22	26	31	35	40	44	48	53
	85000	9	14	19	23	28	33	37	42	47	51	56
	90000	10	15	20	25	30	35	40	44	49	54	59
	95000	10	16	21	26	31	37	42	47	52	57	63
	100000	11	16	22	27	33	38	44	49	55	60	66
	105000	12	17	23	29	35	40	46	52	58	63	69
	110000	12	18	24	30	36	42	48	54	60	66	72
	115000	13	19	25	32	38	44	51	57	63	69	76
	120000	13	20	26	33	40	46	53	59	66	72	79
	125000	14	21	27	34	41	48	55	62	69	75	82
	130000	14	21	29	36	43	50	57	64	71	79	86
	135000	15	22	30	37	44	52	59	67	74	82	89
	140000	15	23	31	38	46	54	61	69	77	85	92
	145000	16	24	32	40	48	56	64	72	80	88	96
	150000	16	25	33	41	49	58	66	74	82	91	99
	155000	17	26	34	43	51	60	68	77	85	94	102
	160000	18	26	35	44	53	61	70	79	88	97	105
	165000	18	27	36	45	54	63	72	82	91	100	109
170000	19	28	37	47	56	65	75	84	93	103	112	
175000	19	29	38	48	58	67	77	86	96	106	115	
180000	20	30	40	49	59	69	79	89	99	109	119	

	Optimal Zone
	Low or high meter speed, may require vacuum adjustment
	Exceeding maximum meter speed, expect performance degradation

Meter Speed (15" Row Spacing 46 Cell Disc - Soybean, Cotton, Surgarbeet/Milo)

		Target Ground Speed (mph)										
		2	3	4	5	6	7	8	9	10	11	12
Target Population (sds/lac)	20000	2	3	4	5	7	8	9	10	11	12	13
	25000	3	4	5	7	8	10	11	12	14	15	16
	30000	3	5	7	8	10	12	13	15	16	18	20
	35000	4	6	8	10	12	13	15	17	19	21	23
	40000	4	7	9	11	13	15	18	20	22	24	26
	45000	5	7	10	12	15	17	20	22	25	27	30
	50000	5	8	11	14	16	19	22	25	27	30	33
	55000	6	9	12	15	18	21	24	27	30	33	36
	60000	7	10	13	16	20	23	26	30	33	36	40
	65000	7	11	14	18	21	25	29	32	36	39	43
	70000	8	12	15	19	23	27	31	35	38	42	46
	75000	8	12	16	21	25	29	33	37	41	45	49
	80000	9	13	18	22	26	31	35	40	44	48	53
	85000	9	14	19	23	28	33	37	42	47	51	56
	90000	10	15	20	25	30	35	40	44	49	54	59
	95000	10	16	21	26	31	37	42	47	52	57	63
	100000	11	16	22	27	33	38	44	49	55	60	66
	105000	12	17	23	29	35	40	46	52	58	63	69
	110000	12	18	24	30	36	42	48	54	60	66	72
	115000	13	19	25	32	38	44	51	57	63	69	76
120000	13	20	26	33	40	46	53	59	66	72	79	
125000	14	21	27	34	41	48	55	62	69	75	82	
130000	14	21	29	36	43	50	57	64	71	79	86	
135000	15	22	30	37	44	52	59	67	74	82	89	
140000	15	23	31	38	46	54	61	69	77	85	92	
145000	16	24	32	40	48	56	64	72	80	88	96	
150000	16	25	33	41	49	58	66	74	82	91	99	
155000	17	26	34	43	51	60	68	77	85	94	102	
160000	18	26	35	44	53	61	70	79	88	97	105	
165000	18	27	36	45	54	63	72	82	91	100	109	
170000	19	28	37	47	56	65	75	84	93	103	112	
175000	19	29	38	48	58	67	77	86	96	106	115	
180000	20	30	40	49	59	69	79	89	99	109	119	

	Optimal Zone
	Low or high meter speed, may require vacuum adjustment
	Exceeding maximum meter speed, expect performance degradation

Meter Speed (20" Row Spacing 46 Cell Disc - Soybean, Cotton, Surgarbeet/Milo)

		Target Ground Speed (mph)										
		2	3	4	5	6	7	8	9	10	11	12
Target Population (sds/ac)	20000	3	4	6	7	9	10	12	13	15	16	18
	25000	4	5	7	9	11	13	15	16	18	20	22
	30000	4	7	9	11	13	15	18	20	22	24	26
	35000	5	8	10	13	15	18	20	23	26	28	31
	40000	6	9	12	15	18	20	23	26	29	32	35
	45000	7	10	13	16	20	23	26	30	33	36	40
	50000	7	11	15	18	22	26	29	33	37	40	44
	55000	8	12	16	20	24	28	32	36	40	44	48
	60000	9	13	18	22	26	31	35	40	44	48	53
	65000	10	14	19	24	29	33	38	43	48	52	57
	70000	10	15	20	26	31	36	41	46	51	56	61
	75000	11	16	22	27	33	38	44	49	55	60	66
	80000	12	18	23	29	35	41	47	53	59	64	70
	85000	13	19	25	31	37	44	50	56	62	68	75
	90000	14	20	26	33	40	46	53	59	66	72	79
	95000	15	21	28	35	42	49	56	63	70	76	83
	100000	15	22	29	37	44	51	59	66	73	81	88
	105000	15	23	31	38	46	54	61	69	77	85	92
	110000	16	24	32	40	48	56	64	72	81	89	97
	115000	17	25	34	42	51	59	67	76	84	93	101
120000	18	26	35	44	53	61	70	79	88	97	105	
125000	18	27	37	46	55	64	73	82	91	101	110	
130000	19	29	38	48	57	67	76	86	95	105	114	
135000	20	30	40	49	59	69	79	89	99	109	119	
140000	20	31	41	51	61	72	82	92	102	113	120	
145000	21	32	42	53	64	74	85	96	106	117	120	
150000	22	33	44	55	66	77	88	99	110	120	120	
155000	23	34	45	57	68	79	91	102	113	120	120	
160000	23	35	47	59	70	82	94	105	117	120	120	
165000	24	36	48	60	72	85	97	109	120	120	120	
170000	25	37	50	62	75	87	100	112	120	120	120	
175000	26	38	51	64	77	90	102	115	120	120	120	
180000	26	40	53	66	79	92	105	119	120	120	120	

	Optimal Zone
	Low or high meter speed, may require vacuum adjustment
	Exceeding maximum meter speed, expect performance degradation

Meter Speed (30" Row Spacing 46 Cell Disc - Soybean, Cotton, Surgarbeet/Milo)

		Target Ground Speed (mph)										
		2	3	4	5	6	7	8	9	10	11	12
Target Population (sds/ac)	20000	4	7	9	11	13	15	18	20	22	24	26
	25000	5	8	11	14	16	19	22	25	27	30	33
	30000	7	10	13	16	20	23	26	30	33	36	40
	35000	8	12	15	19	23	27	31	35	38	42	46
	40000	9	13	18	22	26	31	35	40	44	48	53
	45000	10	15	20	25	30	35	40	44	49	54	59
	50000	11	16	22	27	33	38	44	49	55	60	66
	55000	12	18	24	30	36	42	48	54	60	66	72
	60000	13	20	26	33	40	46	53	59	66	72	79
	65000	14	21	29	36	43	50	57	64	71	79	86
	70000	15	23	31	38	46	54	61	69	77	85	92
	75000	16	25	33	41	49	58	66	74	82	91	99
	80000	18	26	35	44	53	61	70	79	88	97	105
	85000	19	28	37	47	56	65	75	84	93	103	112
	90000	20	30	40	49	59	69	79	89	99	109	119
	95000	21	31	42	52	63	73	83	94	104	115	120
	100000	22	33	44	55	66	77	88	99	110	120	120
	105000	23	35	46	58	69	81	92	104	115	120	120
	110000	24	36	48	60	72	85	97	109	120	120	120
	115000	25	38	51	63	76	88	101	114	120	120	120
120000	26	40	53	66	79	92	105	119	120	120	120	
125000	27	41	55	69	82	96	110	120	120	120	120	
130000	29	43	57	71	86	100	114	120	120	120	120	
135000	30	44	59	74	89	104	119	120	120	120	120	
140000	31	46	61	77	92	108	120	120	120	120	120	
145000	32	48	64	80	96	111	120	120	120	120	120	
150000	33	49	66	82	99	115	120	120	120	120	120	
155000	34	51	68	85	102	119	120	120	120	120	120	
160000	35	53	70	88	105	120	120	120	120	120	120	
165000	36	54	72	91	109	120	120	120	120	120	120	
170000	37	56	75	93	112	120	120	120	120	120	120	
175000	38	58	77	96	115	120	120	120	120	120	120	
180000	40	59	79	99	119	120	120	120	120	120	120	

	Optimal Zone
	Low or high meter speed, may require vacuum adjustment
	Exceeding maximum meter speed, expect performance degradation

**Meter Speed (30" Row Spacing 23 Cell Sunflower Disc)**

		Ground Speed (mph)										
		2	3	4	5	6	7	8	9	10	11	12
<b>Population Setpoint (sds/ac.)</b>	16000	7	10	14	18	21	25	28	32	35	39	42
	18000	8	12	16	20	24	28	32	36	39	43	47
	20000	9	13	18	22	26	31	35	39	44	48	53
	22000	10	14	19	24	29	34	39	43	48	53	58
	24000	11	16	21	26	32	37	42	47	53	58	63
	26000	11	17	23	28	34	40	46	51	57	63	68
	28000	12	18	24	31	37	43	50	55	61	68	74
	30000	13	20	26	33	39	46	53	59	66	72	79
	32000	14	21	28	35	42	49	56	63	70	77	84
	34000	15	22	30	37	45	52	60	67	75	82	90
	36000	16	24	32	39	47	55	63	71	79	87	95

	Optimal Zone
	Low or high meter speed, may require vacuum adjustment
	Exceeding maximum meter speed, expect performance degradation

---

## TRUE SPEED SEED METER COVER REMOVAL

1. Push latch and rotate cover clockwise.



2. Select seed disc and ejector to match crop and population.

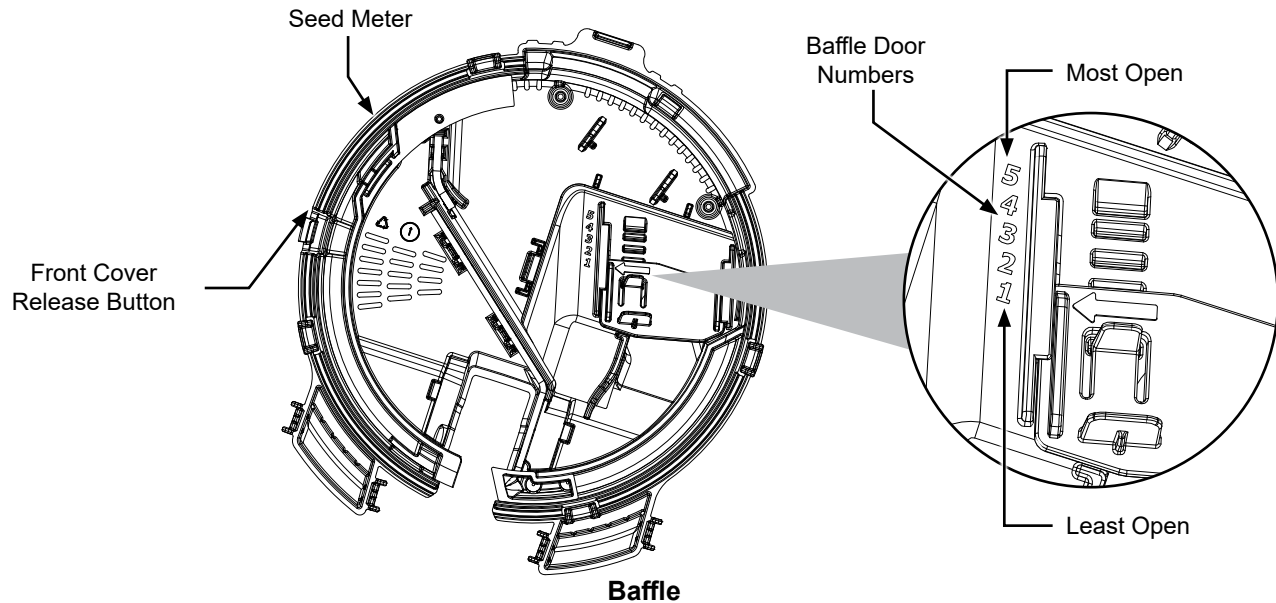

**NOTE: Damaged seed or seed containing foreign material will cause plugging of seed disc orifices and require more frequent seed meter cleanout to prevent underplanting.**

#### Wheel-Type Ejectors

Wheel-type ejectors expel seed and remnants from seed disc cells. These ejectors are disc specific, color-coded to match their corresponding disc, and necessary for proper meter performance.

**NOTE: Seed size, seed shape, seed treatments, travel speed, and planting rate affect meter performance.**

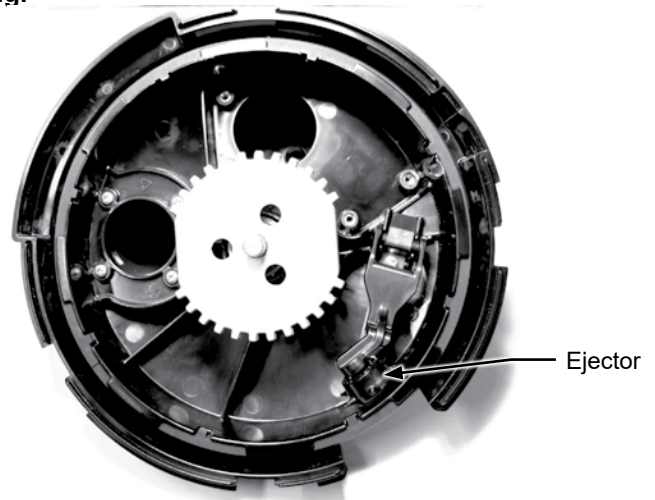

3. Adjust baffle door to recommended setting.
4. Install cover and rotate counter-clockwise.
5. With vacuum fan running, use priming sequence on Blue Vantage display to load seed onto seed discs.

**NOTE: Vacuum reading will be much lower when seed disc cells are empty. Prime seed meters and allow vacuum to stabilize before starting to plant.**

**ADDITIVES**

<b>Lubricant Application Rate</b>	
<b>Graphite</b>	
Conventional Hoppers	1 Tbs./Hopper Fill
Bulk Fill Hoppers	1 Pound Bottle/50 Unit Fill
<b>80/20 Talc-Graphite</b>	
Conventional Hoppers	1/2 C.**
Bulk Fill Hoppers	8 Pounds/50 Unit Fill**
**Must be evenly mixed during fill.	
<b>Talc</b>	
Conventional Hoppers	1/4 C.*
Bulk Fill Hoppers	4 Pounds/50 Unit Fill*
*Double amount of talc for sunflowers.	

GRAPHITE

The use of graphite is the primary recommendation to promote seed flow, provide lubrication for the seed meter and to help dissipate static charge buildup. Among the available dry seed lubricants graphite is the most effective and easiest to use and it requires no mechanical agitation

Conventional Hoppers

Mix one tablespoon of **powdered graphite** with seed each time hoppers are filled. Regular graphite use prolongs life of the seed meter components, improves seed spacing, and may reduce buildup of seed treatments.

**NOTE: DO NOT apply graphite only in center of hopper. It will filter too quickly through the seed and not distribute as evenly as desired.**

Apply graphite around outer perimeter of hopper.

Bulk Fill Hoppers

Mix 1 pound bottle of powdered graphite each time the bulk seed hopper is filled. Graphite should be added in layers as the bulk seed hoppers are filled. Regular graphite use prolongs life of the seed meter components, improves seed spacing, and may reduce buildup of seed treatments.



Adding graphite to conventional hopper



Adding graphite bulk fill hopper

**NOTE: Additional graphite may be required to retard buildup of seed treatments on meter components. More frequent cleaning of monitor seed tubes may be necessary due to use of additional graphite.**



### 80/20 TALC-GRAPHITE

Talc-Graphite lubricant is to be used for treated seed, providing benefits of both talc and graphite. It absorbs moisture to prevent bridging, minimizes static electricity for improved seed flow, and lubricates seed and meters.

#### Conventional Hoppers

Mix ½ C. of 80/20 talc-graphite evenly with seed each time hoppers are filled. Regular graphite use prolongs life of the seed meter components, improves seed spacing, and may reduce buildup of seed treatments.

**NOTE: Talc-Graphite lubricant MUST be mixed evenly during fill.**

#### Bulk Fill Hoppers

Mix 8 lbs. of 80/20 talc-graphite each time the bulk seed hopper is filled. Regular graphite use prolongs life of the seed meter components, improves seed spacing, and may reduce buildup of seed treatments.

**NOTE: Talc-Graphite lubricant MUST be mixed evenly during fill.**

### TALC

**Talc seed lubricant** may be used as a drying agent in addition to graphite lubrication. The drying agent may improve seed release and/or **to retard buildup of seed treatments on meter components.**

1. Fill hopper ½ full of seed, add ¼ cup (conventional); 2 pounds (Bulk Fill) of talc and **mix thoroughly.**
2. Finish filling hopper, add another ¼ cup (conventional); 2 pounds (Bulk Fill) of talc and **mix thoroughly.**
3. Adjust rate of talc use as needed so all seeds are coated, while avoiding a buildup of talc in bottom of hopper.

Humid conditions and/or small sized seeds with extra seed treatment may require additional talc to maintain meter performance.

**NOTE: Liquid seed treatments or inoculants may create buildup on the seed disc or brushes. Check frequently for proper population and/or seed delivery when using any liquid seed treatment.**

Completely mix all treatments with seed following manufacturers' recommendations. Seed treatment dumped on top of seed after hopper is filled may not mix properly and cause seed bridging, reducing population or stopping meter from planting.

## **BAYER FLUENCY AGENT**

Bayer Fluency Agent is an alternate seed lubricant by Bayer Crop Science. The intent of this product is to replace graphite and talc lubricants and to lower the amount of dust emissions from planter vacuum fans.

This product, as tested by Kinze, is compatible with Kinze's bulk fill system and vacuum meters. Due to limited testing, wear life characteristics of meters and bulk fill systems that use Bayer Fluency Agent are not yet known. Please follow Bayer Fluency Agent instructions for rates and mixing directions.

**NOTE: Presently, Bayer Fluency Agent is only required to be used in Canada with Bulk Fill or Vacuum planters that plant corn or beans treated with neonicotinoids. Farms outside of Canada, farms not using seed treated with neonicotinoids, and farms not using pneumatic metering devices do not need to use Bayer Fluency Agent. All planters not equipped with vacuums or fans are exempt from using Bayer Fluency Agent.**

**GRANULAR CHEMICAL**



**WARNING**



Agricultural chemicals can cause death or serious injury to persons, animals, and plants or seriously damage soil, equipment, or property. Read and follow all chemical and equipment manufacturers labels and instructions.

**NOTICE**

Do not store granular products in granular chemical hoppers. High humidity or rain may cause stored granular products to bind and block the product from flowing.

The granular chemical hopper has a 1.4 cubic feet capacity.

Make sure no foreign objects get into hopper when it is being filled. Replace hopper lids after filling to prevent accumulation of dirt and moisture.

A metering gate on bottom of hopper regulates the application rate. See “Dry Insecticide and Dry Herbicide Application Rate Charts” in this manual. Calibrate using chemical manufacturers’ instructions.

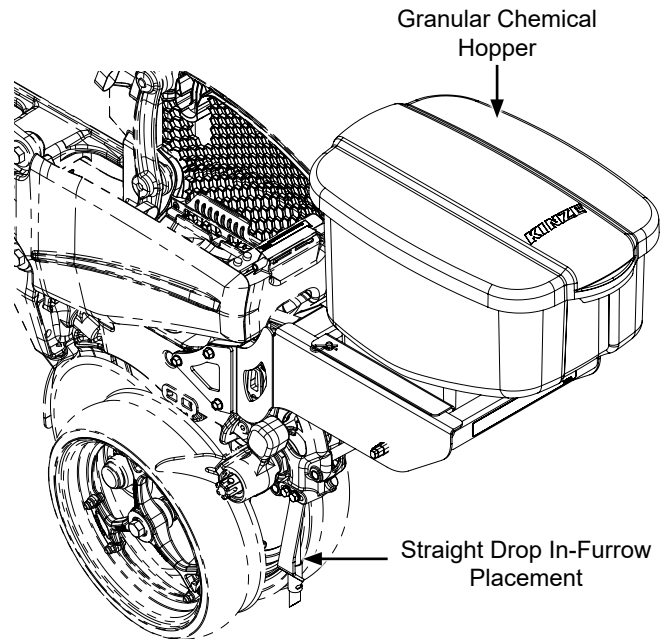

**GRANULAR CHEMICAL BANDING OPTIONS**

Granular chemical banding options allow 4½” slope-compensating banding, straight drop in-furrow placement or 14” rear banding.

**NOTE:** Granular chemical rear bander is not compatible with covering discs/single press wheel option.

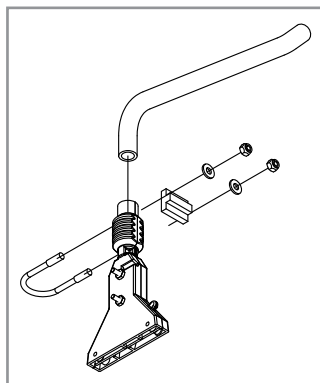

**4½” Slope-compensating Bander**

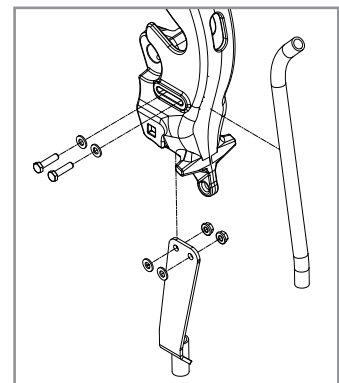

**Straight Drop In-furrow Placement**

## ROW UNIT MOUNTED NO TILL COULTER

Row unit mounted no till coulters may be used on row units.

Coulter blade can be adjusted to one of four 1/2" incremental settings in the forked arm. Initial location is the top hole.

Move blade as it wears to one of the three lower holes to maintain coulters at or slightly above opener discs. Adjust coulters below depth of double disc opener blades in very hard soil conditions such as compacted wheel tracks to improve opener penetration and cutting of surface residue.

Check operating depth by setting planter down on a level concrete floor and checking relationship between coulters and row unit opener blade. Make sure planter is level and coulters are square with planter frame and aligned with row unit disc opener.

**NOTE:** Torque 5/8" spindle hardware to 120 ft-lb (162.7 N-m).

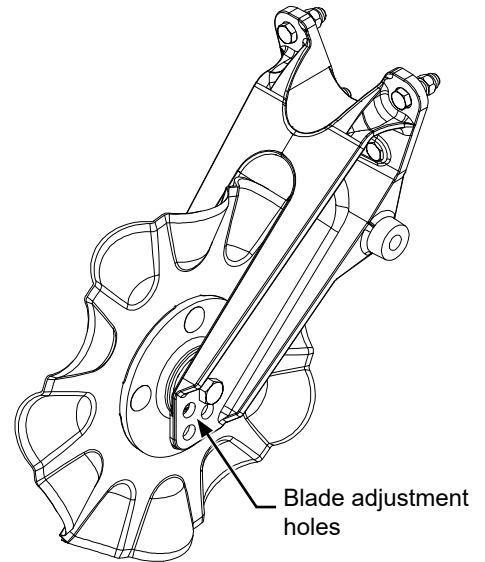

**Row Unit Mounted No Till Coulters**

## COULTER MOUNTED RESIDUE WHEELS

Coulter mounted residue wheels are designed for use on row units.

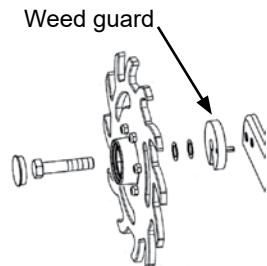

**NOTE: Opening in weed guard must face down.**



**Coulter Mounted Residue Wheels**

Residue wheels attach to row unit mounted coulter with two cap screws and sleeves allowing unit to free-float. A 2-position spindle bolt mounting positions wheels interlocked or staggered. Depth adjustment is made with a spring-loaded cam and pin with 8 positions in  $\frac{7}{16}$ " increments. A high point on the cam allows wheels to be locked up.

A weed guard on the inboard side of each wheel helps prevent weed wrap which can cause premature bearing failure.

## SYSTEM OVERVIEW

Fertilizer is controlled through the Blue Vantage Display. You can increase or decrease fertilizer rate, turn fertilizer function on or off, and load a prescription. Refer to your Blue Vantage manual for more information.

## LIQUID FERTILIZER ATTACHMENT



### WARNING



Agricultural chemicals can cause death or serious injury to persons, animals, and plants or seriously damage soil, equipment, or property. Read and follow all chemical and equipment manufacturers labels and instructions.



### CAUTION

Overfilling tank can cause siphoning, tank collapse, personal injury, and damage to property and equipment. Do not overfill tank. Do not leave planter unattended when filling tank. Close fill valve and open tank lid if siphoning occurs. Follow all chemical manufacturers first aid, cleanup, and handling instructions.

### NOTICE

Placing fertilizer too close to seeds or in excessive amounts can cause germination or seedling damage. Check with your fertilizer dealer or manufacturer for correct amount and placement.



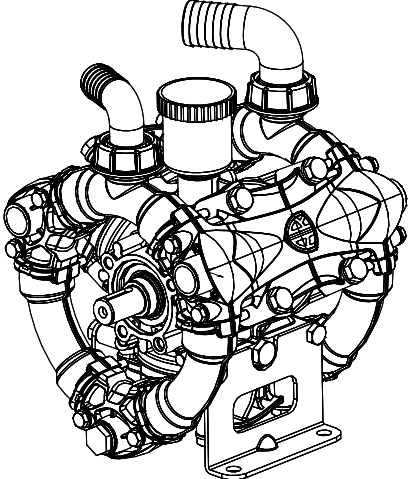
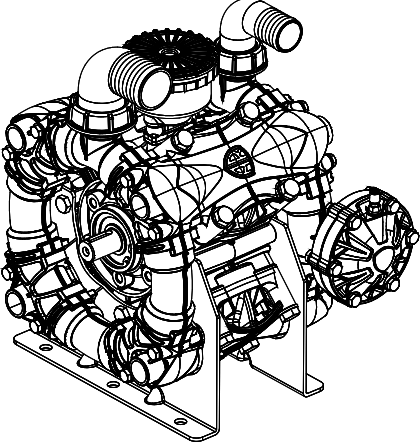
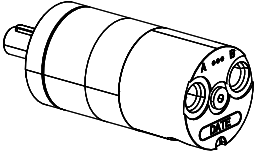
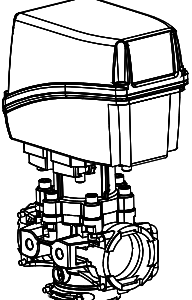

**Fertilizer Systems Parts Overview**

**NOTE:** See parts manual for part numbers.

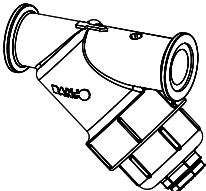
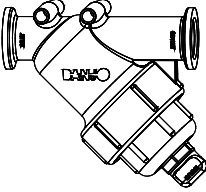
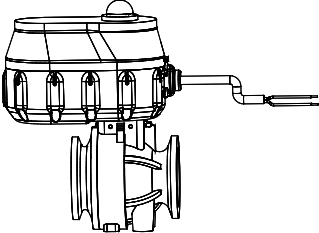
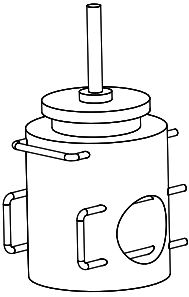
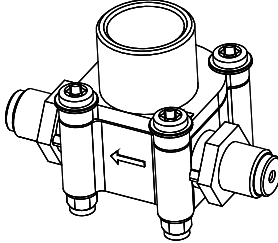
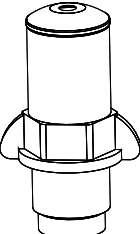
COMPONENT		DESCRIPTION
Diaphragm Pumps	 <p data-bbox="391 919 675 951">3 Cylinder (24 Row 20")</p>	<p data-bbox="781 422 1166 447">Small pump, used on 40' toolbar.</p> <p data-bbox="781 485 1003 510">Oil Capacity: 36 oz</p> <p data-bbox="781 548 1312 699">Diaphragm Kit: Available, see parts manual. Check Valve Kit: Available, see parts manual. Seal Kit: Available, see parts manual. Oil: Available, see parts manual. Winterizer: Available, see parts manual.</p>
	 <p data-bbox="358 1430 711 1486">4 Cylinder (24 Row 30" and 36 Row 20")</p>	<p data-bbox="781 968 1182 993">Large pump, used on 60' toolbars.</p> <p data-bbox="781 1031 1239 1056">Pneumatic Pulsation Dampener: 15 psi</p> <p data-bbox="781 1094 1003 1119">Oil Capacity: 56 oz</p> <p data-bbox="781 1157 1312 1308">Diaphragm Kit: Available, see parts manual. Check Valve Kit: Available, see parts manual. Seal Kit: Available, see parts manual. Oil: Available, see parts manual. Winterizer: Available, see parts manual.</p>
Hydraulic Motor		<p data-bbox="781 1503 1450 1560">Fertilizer Pump Motor. Small pump and large pump have different motors.</p> <p data-bbox="781 1598 1219 1623">Seal Kit: Available, see parts manual.</p>
Pressure Regulator		<p data-bbox="781 1682 1369 1738">Controls delivery manifold pressure and bypasses overhead flow for agitation.</p>

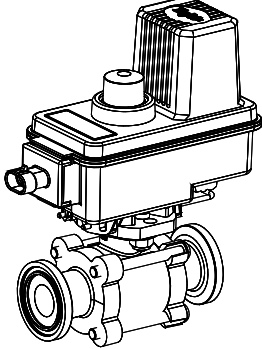
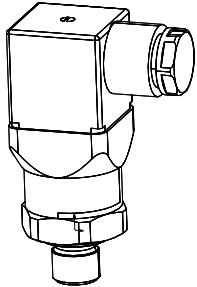
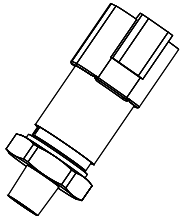
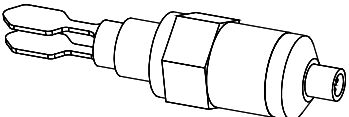
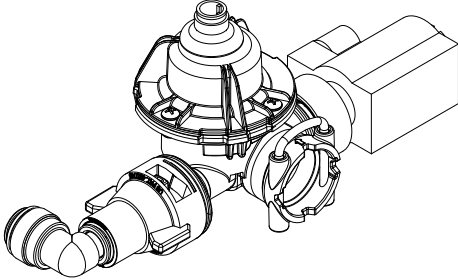
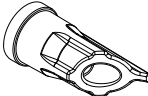
COMPONENT		DESCRIPTION
Suction Strainer		30 mesh.  Clean regularly.
Pressure Strainer		80 mesh.  Clean regularly.
Suction Ball Valve		On/off valve that opens flow of fertilizer to the pump. This is feature is used when entering planting task in Blue Vantage.
Large System Flow Meter		Full flow flow meter.
Small System Flow Meter		Arrows on housing indicates direction of flow.
		Small flow meter sensor.

COMPONENT		DESCRIPTION
Small Ball Valve		Closes to send flow through small flowmeter at low flow rates.
Suction Sensor		Located in suction strainer. Sends pump suction pressure to Blue Vantage controls.
Pressure Sensor		Sends delivery manifold pressure to Blue Vantage controls.
Fluid Switch		<p>Located in tank for low level alert.</p> <p>Located in suction circuit to know when to indicate pump has fluid supply.</p>
Row Flow Meter		Indicates flow or no flow to each row.
Jet Orifice		Used for all orifices smaller than .055 and not used for .065 and larger.
4916 Orifice		Differen orifices used for different application rates.

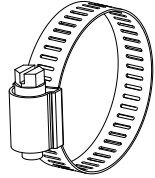
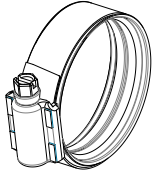

Hose Clamp Torque Values Chart				
 Standard	 Heavy Duty	Diameter	Standard	Heavy Duty
		1¼"	42 in-lb	75 in-lb
		1½"	42 in-lb	75 in-lb
		2"	42 in-lb	X

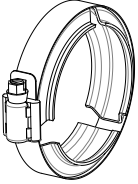
Flange Clamp Torque Values Chart		
	Diameter	Torque
	1"	50-60 in-lb
	2"	90-100 in-lb

### Liquid Fertilizer System Schematics

Fertilizer is controlled through the Blue Vantage display. Increase or decrease fertilizer rate, turn fertilizer function on or off, and load prescription. Refer to your Blue Vantage manual for more information.

#### Rear Trailer or Hitch Auxiliary Tank

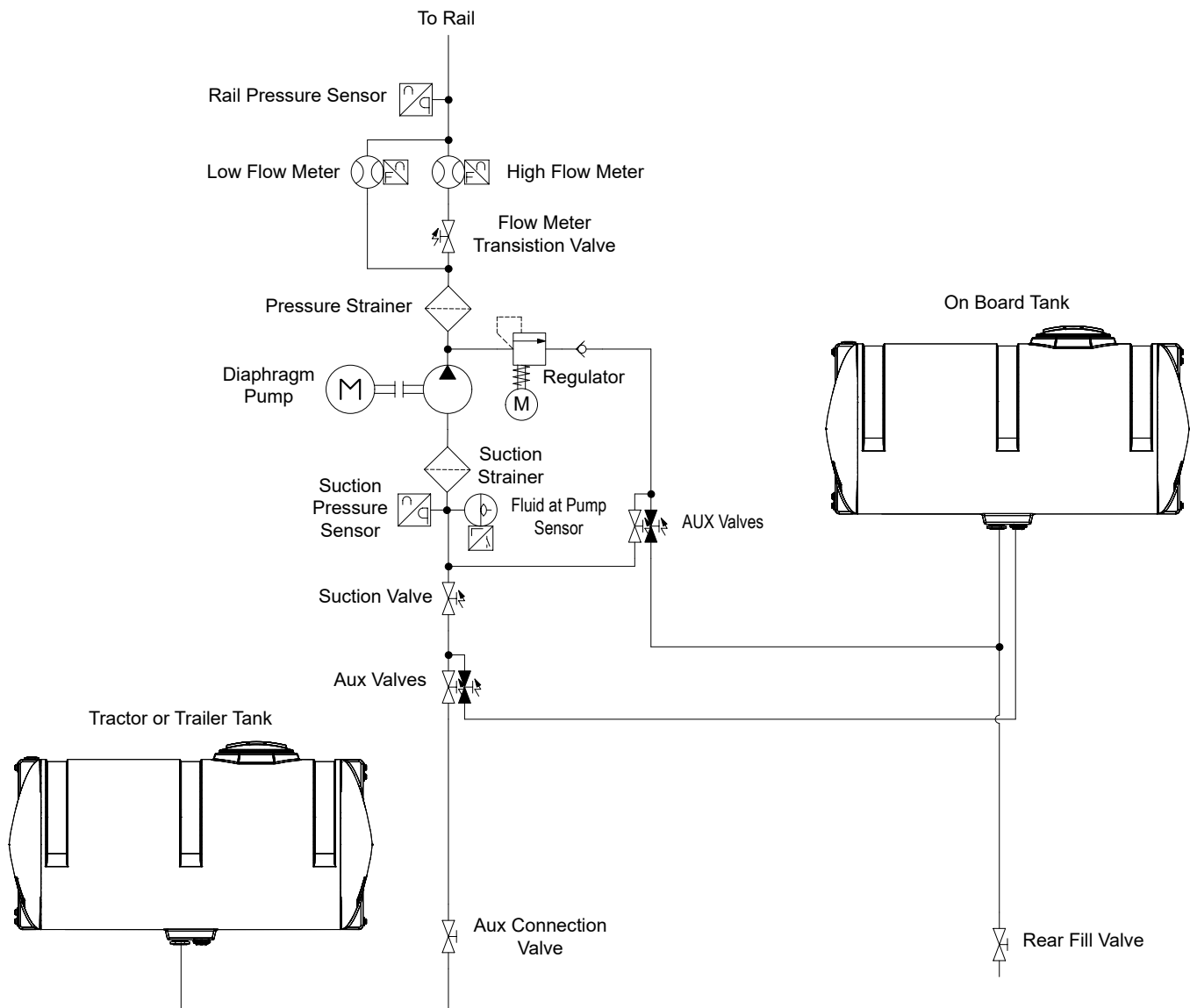

**System Overview**

Diaphragm Pump - Model Number AR120

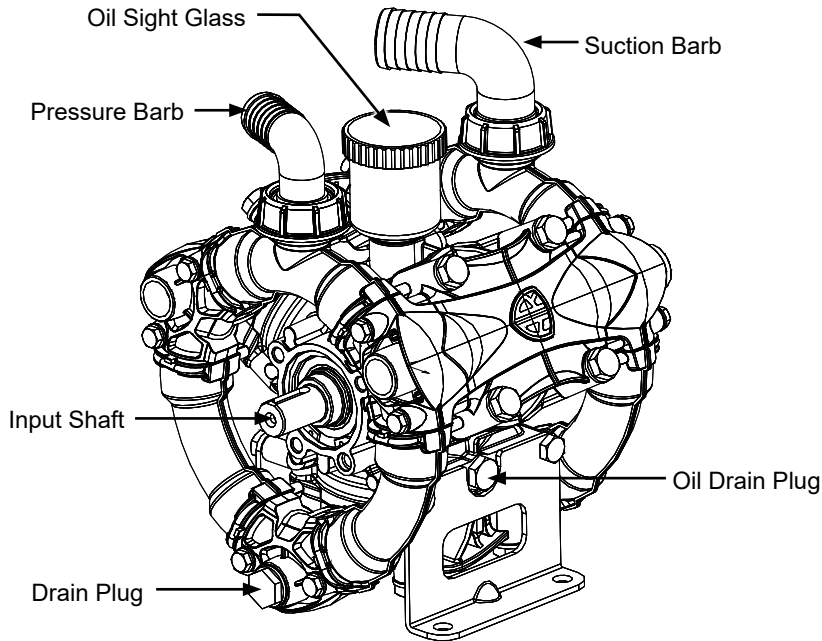

Operating Pressure Range		
	AR120	AR160
<b>Max GPM</b>	30.8	43.9
<b>Max PSI</b>	220	218
<b>Weight</b>	34 lbs	55 lbs
<b>Cylinders</b>	3	4
<b>Oil Capacity</b>	36 oz	56 oz
<b>Max Speed</b>	550	550
<b>Pulsation Damper</b>	No	Yes

Diaphragm Pump - Model Number AR160

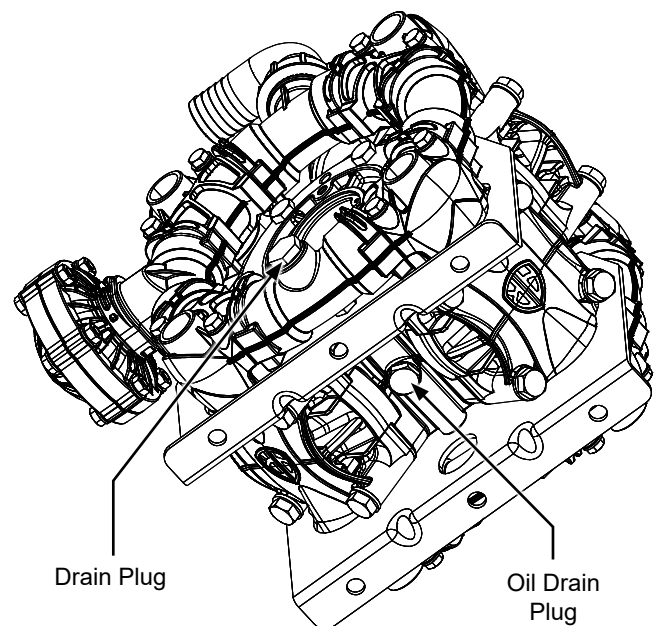
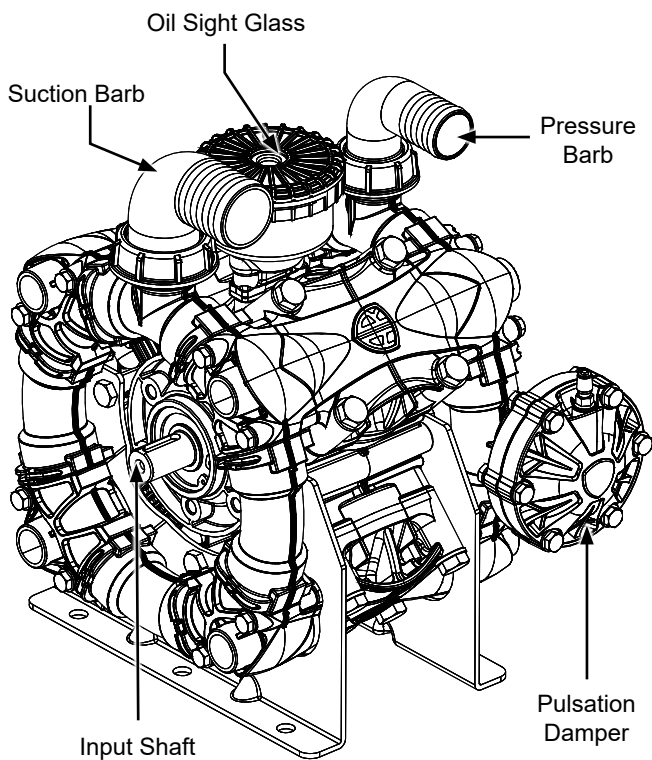

Diaphragm pumps are reciprocating positive displacement pumps. Reciprocating movement of the diaphragms expands and compresses volumes. This mechanical work and change in volumes cause transfer of liquid. The main difference between a diaphragm pump and other types of reciprocating pumps, is the presence of a flexible separating component (the diaphragm) between mechanical parts and pumped liquid circuit. This enables diaphragm pumps to transfer liquids which would be detrimental to other types of reciprocating pumps. Pistons are generally in a “Boxer” type opposing cylinder arrangement, or in a radial layout around the axis of the crankshaft which drives them.

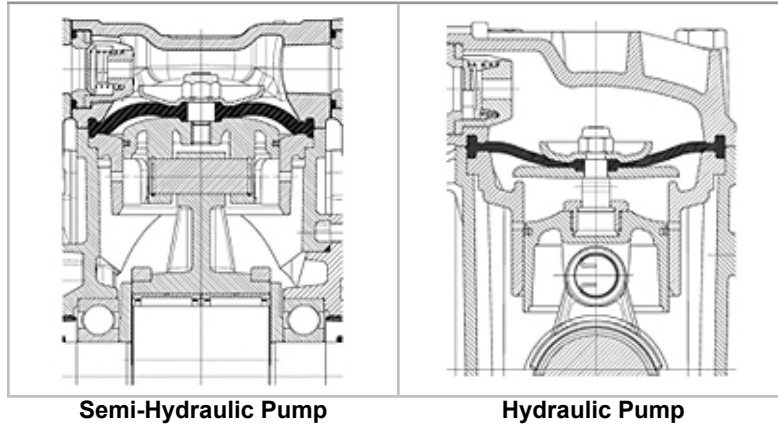

The piston is mechanically connected to the diaphragm. The diaphragm is mechanically operated by the piston at its center and at the same time its outer edge ensuring a watertight seal around the pumping chamber. In a “semi-hydraulic diaphragm pump”, the diaphragm is rigidly secured to the piston by a stud screwed on the piston and a plate tightened by a nut. In a “Hydraulic diaphragm pump” the center of the diaphragm is fixed to a floating component on piston. The suction and delivery valves, fitted at the pumping chamber suction and delivery ports, are operated by the alternating negative and positive pressure inside circuit.

Suction

During the suction stroke (piston retreating), the difference between the suction pressure and the pressure inside the pump head opens the suction valve and closes the delivery valve. The transferred liquid is drawn into the head by the suction line.

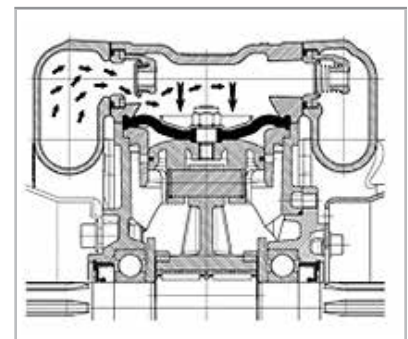

**Suction**

Compression

During the compression stroke (advancing piston), the suction valve closes and the delivery valve opens due the pressure generated inside the head by the piston. The transferred liquid is pumped out of the head and into the delivery line.

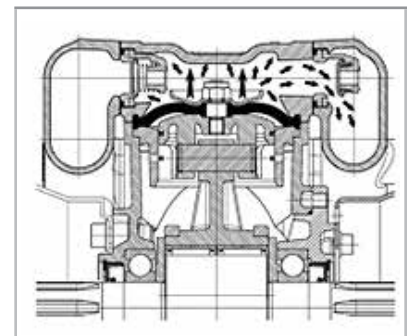

**Compression**

Oil

When pump is new, oil in tank is clear and yellowish in color. After a few operating hours, the oil in tank loses its transparency and becomes dark due to metal particles removed by rubbing of internal components during functioning. This is normal color for this type of diaphragm pump. This occurs regardless of the type of oil used and pump's working conditions. In heavy-duty working conditions, oil will become dark more quickly. When oil in the tank becomes light grey and looks milky (color also depends on color of the liquid being pumped), stop using the pump immediately, it is likely that one or more diaphragms have ruptured, allowing the aqueous solution pumped to pass into the lubricating oil and form a water/oil emulsion inside pump body.



Oil in New Pump



Oil in Functioning Pump



Oil After Diaphragm Rupture

Replacing Diaphragms

Aside from its lubricating function, in diaphragm pumps the oil passes through the calibrated holes in the sleeves uncovered at every piston stroke to form a protective cushion between piston and diaphragm. The volume of this oil cushion is not constant; it varies with pressure/vacuum inside pumping chamber. However, the oil cushion is only effective when it does not contain residual air. After replacing diaphragms the oil cushion should be restored, by removing as much air as possible inside the body and specifically between pistons and diaphragms.

Restore oil cushion:

1. Calibrated holes in the sleeves must always be mounted in vertical position, allowing air to flow out, and cap must be off tank.
2. Before proceeding weigh quantity of oil stated in manual for the specific pump model.
3. Turn pump shaft by hand and tilt at various angles; air bubbles will be seen coming out of tank.
4. When the entire amount of oil specified for the pump has been poured in, oil is between the minimum and maximum level marks on the tank and no air is bubbling out. The system has been vented correctly.

**NOTE: Particularly heavy or bulky pumps can be operated at low RPM for a few minutes at 0 bar without oil cap on oil sight reservoir. Air bubbles will come out, causing level to drop. Top up until entire quantity of oil specified for the pump has been added.**

**NOTE: During operation, if working pressure increases, the level in tank will increase, if pump is working with a high suction pressure (obstructed filter, suction from a strong gradient), level in tank will reduce.**

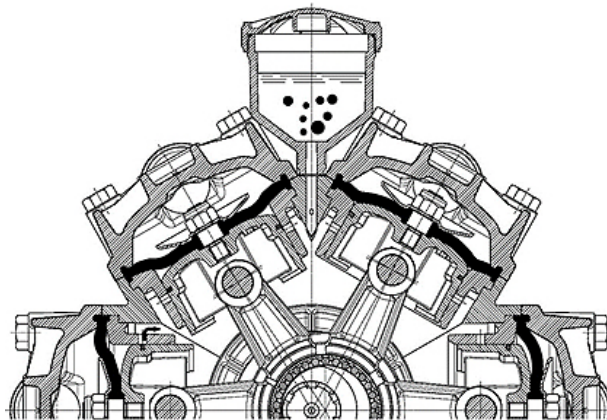

## PULSATION DAMPER (DIAPHRAGM PUMP) - MODEL NUMBER AR160 ONLY

The hydropneumatic damper consists of two half circular bodies separated by an elastomer diaphragm which also provides a watertight seal outwards. One of the two damper halves is connected to the delivery circuit, the other is filled with pressurized air, or in some cases Nitrogen, by means of an inflation valve of the kind used on car tires. The aim is to create an air bubble, with rigidity which can be varied by varying the inflation level, to absorb the waves produced in the delivery circuit liquid by the motion of the pump's pistons. In general, a higher operating pressure will require a higher damper inflation pressure, as indicated on the sticker provided. The damper pressure must be checked before each use of the pump.

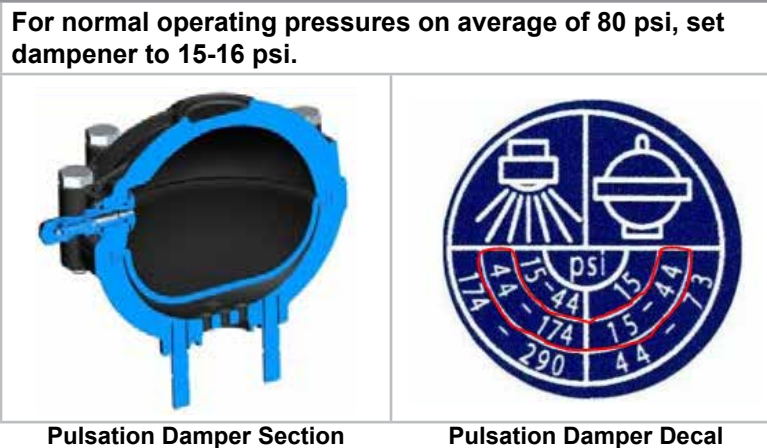

### Improper Fertilizer Pump Operation

- Do not use the pump in a potentially explosive atmosphere.
- Do not use the pump for flammable, or liquids with unsuitable density, especially seawater, adhesives, bitumens, asphalt sealers, two-step curing compounds, concrete sealers, liquefied gases or solvents of any kind, paints of any kind or liquids containing solids in suspension.
- Do not draw in liquids at temperatures above 122°F (50°C) or below 41°F (5°C).
- Do not use the pump in drinking water supply systems.
- Do not use the pump on products for human consumption.
- Do not use the pump without first checking that the intake and delivery circuit pipelines are correctly secured and free from leaks.
- Do not use the pump without the safety devices provided: guards for shafts and drive couplings and suitably rated relief valve on the delivery circuit.
- Do not use the pump to wash or spray: people, animals or delicate items, live electrical equipment or chemicals whose characteristics are not known.

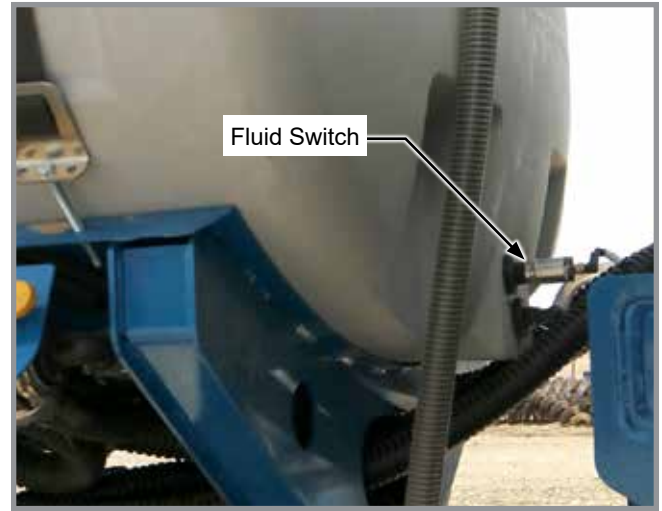
**FERTILIZER TANK****24 Row - Front View****24 Row - Rear View****Fertilizer Pressure Gauge**

Pressure gauge is connected directly to the fertilizer pressure manifold. The analog pressure gauge is located on the front of liquid fertilizer tank. Visually check from tractor cab that the sensor is reading the pressure of the system correctly.

**Fertilizer Level Sight Glass**

Indicates how much liquid is left in fertilizer tank(s). Planter must be on level ground to get an accurate level.

**Fluid Switch and Liquid Level Sensor**

Green = Has power, but no fluid is present; Green/Orange = Fluid is present

Servicing Pump

Refer to the parts manual for all service kit part numbers. Use the chart below for maintenance intervals.

MAINTENANCE INTERVAL	ACTION
Each time used.	Check level and status of oil.
	Check suction filter and clean if necessary.
Every 50 hours.	Check pulsation damper inflation pressure (if applicable).
	Check if suction line is intact.
	Check if pump is tightly fastened to chassis of machine. <b>NOTE: Should the pump not be securely fastened, <u>DO NOT</u> use the machine for any reason.</b>
Every 300 hours.	Check the diaphragms and replace if necessary. Replace all diaphragms in the pump, regardless of conditions if aggressive chemicals are used.
	Check damper diaphragm (if applicable) and replace if necessary.
	Replace oil. Oil <b>MUST</b> be changed every time diaphragms are replaced. First oil change must be made after 300 hours.
	Check to be sure pump screws are tight. If pump operates in conditions of heavy vibration, check more frequently.

Checking Oil Level

- Check oil with pump level, ensuring that it has been running for at least 5 minutes in normal working conditions.
- If oil level is not visible or completely full, add or remove oil to restore this level and check, still with the pump running, that the oil level does not vary so much that it leaks from the cap or is no longer visible in tank.
- If necessary, add oil with A/R Premium Diaphragm Pump Oil.
- Check oil level regularly, as it may vary significantly with operating conditions.





### Changing Pump Oil

1. Remove top two hoses from pump (suction and pressure will unscrew from pump).
2. Remove hydraulic motor from pump flange.
3. Unplug pump speed sensor.
4. Remove pump from planter.
5. Loosen cap on oil sight glass.
6. Pull oil drain plug.
7. Use a container of adequate size to drain about 36 oz (AR120) or 56 oz (AR160) of oil from pump. **NOTE: Some oil may be caught behind diaphragms, 36 oz or 56 oz may not come out.**
8. Reinstall drain plug.
9. Refill pump with about 36 oz (AR120) and 56 oz (AR160) of oil. You may need to wait to top the pump off until the pump is back on the planter using the purge/spin button on the blue vantage to spin the pump and get all oil circulated. When oil level stops going down it is adequate.
10. Reinstall pump onto planter (reconnect hydraulic motor to the flange, reconnect pressure and suction hose).
11. Reinstall pump speed sensor.

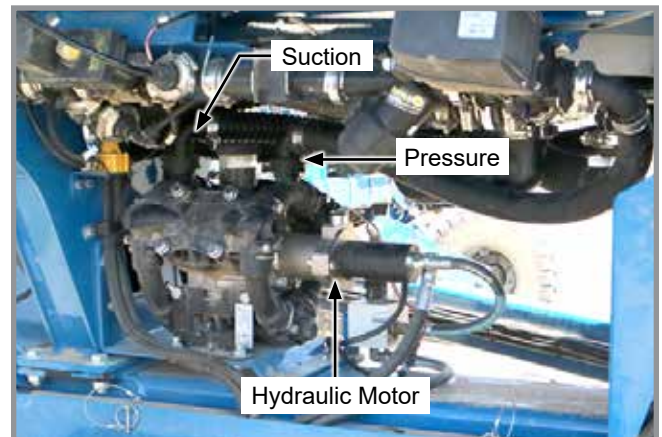

**ROW FLOW METER****End View**

When planter toolbar is on level ground, check to ensure all flow meters are also as horizontal as possible for best operation. If flow meter is not level while planter is on level ground, adjust by rotating manifold(s).

## ROW FLOW METER CLEANOUT

Fertilizer can salt out when certain conditions of time and temperature are met. This causes a buildup of fertilizer granules in and around areas of low flow. This will cause errors in the performance of the fertilizer flow manifold.

To properly clean, disassemble the entire assembly. Use the illustrations below as a guide for disassembly and reassembly.

Clean all parts thoroughly with clean water at the end of planting season or prior to an extended period of non-use. Do not allow fertilizer to crystallize from cold temperatures or evaporation.

1. Turn cover counterclockwise to unlock and remove cover from flow meter.

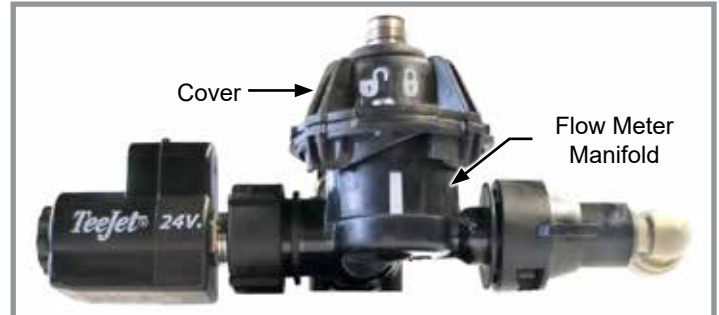

2. Remove paddle wheel from cavity.
3. Clean all parts thoroughly with clean water. Remove any debris inside of cavity.

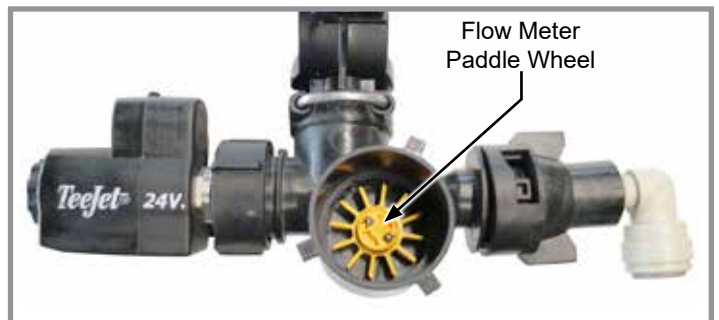

4. Once clean, place paddle wheel back onto pin inside cavity and spin the paddle wheel to ensure it is seated correctly.



5. Reinstall cover and turn clockwise until the "lock symbol" is directly above the white line.

**NOTE: If cover does not go on easily, paddle wheel is not aligned correctly on pin.**



**ROW FLOW METER JET ORIFICE REMOVAL**

1. Turn cover counterclockwise to unlock and remove cover from flow meter.

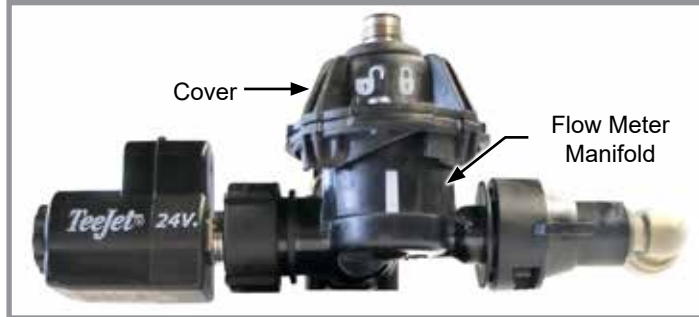

2. Remove paddle wheel from cavity.

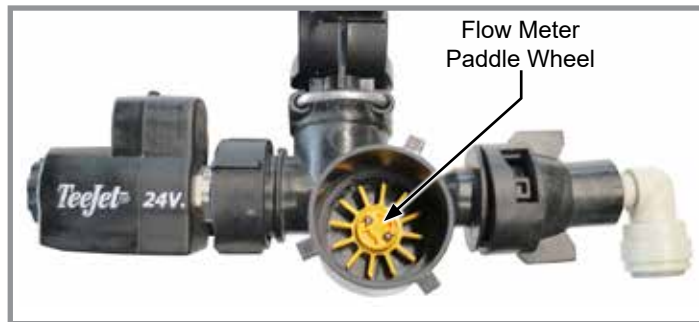

3. Rotate the nozzle assembly counterclockwise 90° and pull nozzle off.
4. Pull strainer out of flow meter.
5. Remove row shutoff valve by spinning nut counterclockwise and pulling valve out.



## 6. Remove jet orifice:

- Insert #1 Phillips screwdriver from the nozzle assembly side until the tip is in the jet orifice as shown. Then push the jet orifice out.

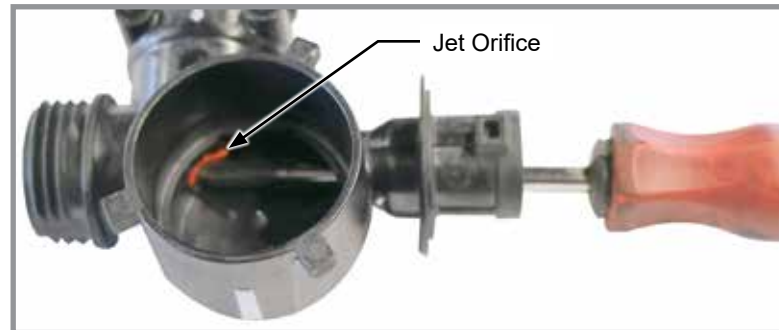

## 7. Reassemble flow meter

- Reinstall row shutoff valve and tighten nut clockwise.
- Place the paddle wheel on the pin in the cavity and spin paddle wheel to ensure it is seated correctly.
- Reinstall cover and turn clockwise until the lock symbol is directly above the white line.
- Reinstall strainer.
- Reinstall gasket, orifice, and nozzle assembly.

## ROW FLOW METER JET ORIFICE INSTALLATION

1. Remove row shutoff valve by spinning nut counterclockwise and pulling valve out.
2. Turn cover counterclockwise to unlock and remove cover from flow meter.
3. Place jet orifice on the end of #1 Phillips screwdriver, with the long tip closest to the rail and pointing toward the paddle wheel cavity.
4. Insert jet orifice into center hole on the row shutoff valves, gently twisting back and forth to help align the rib on the orifice and the groove in the housing. The jet orifice should be flush with paddle wheel cavity wall when installed completely.
5. Reinstall row shutoff valve and tighten nut clockwise.
6. Place paddle wheel on the pin in the cavity and spin the paddle wheel to ensure it is seated correctly.

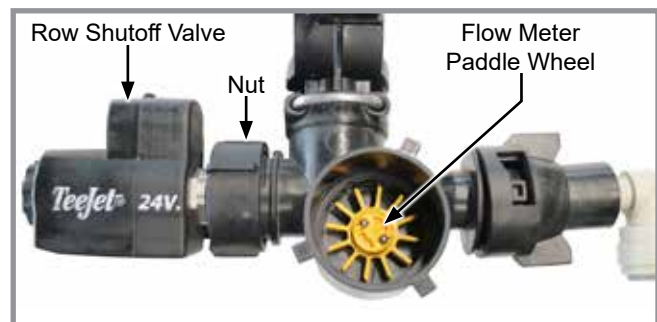
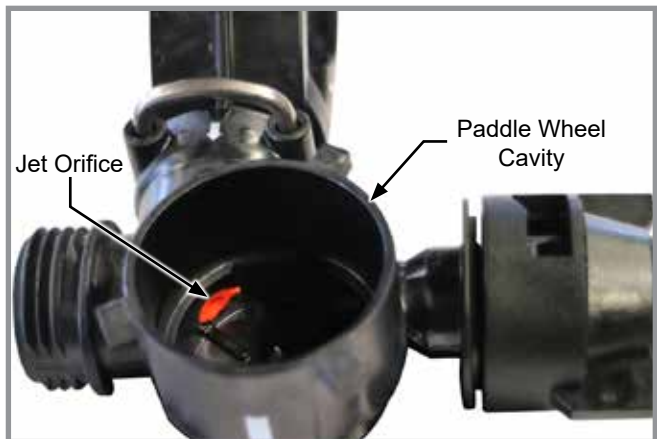
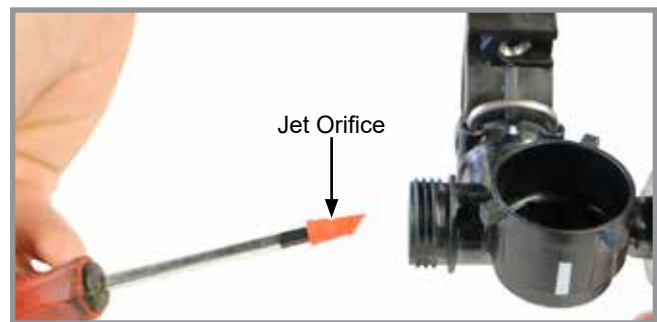
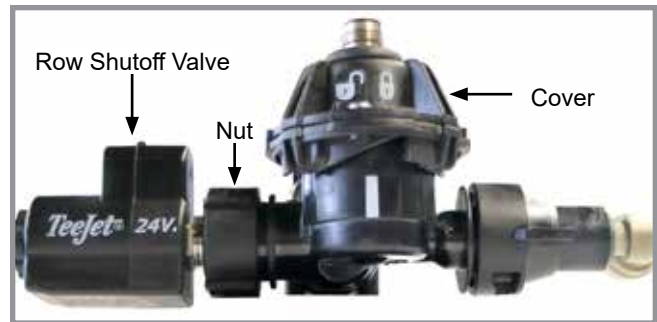

- 7. Reinstall cover and turn clockwise until the lock symbol is directly above the white line.



- 8. Reinstall strainer.

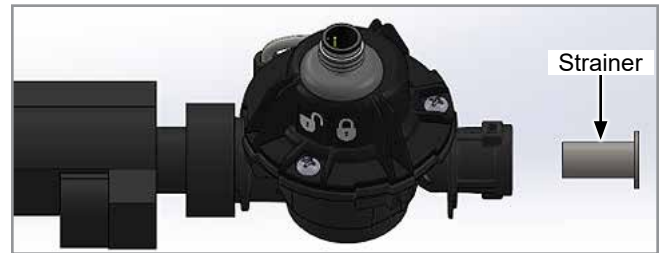

- 9. Reinstall gasket, orifice, and nozzle assembly.

**NOTE: Orifices must be installed correctly. Install orifice with the blank side towards the flow meter manifold and the stamped side facing nozzle assembly (pointing downstream toward the direction of delivery).**

**NOTE: Orifice is installed in center groove of gasket.**

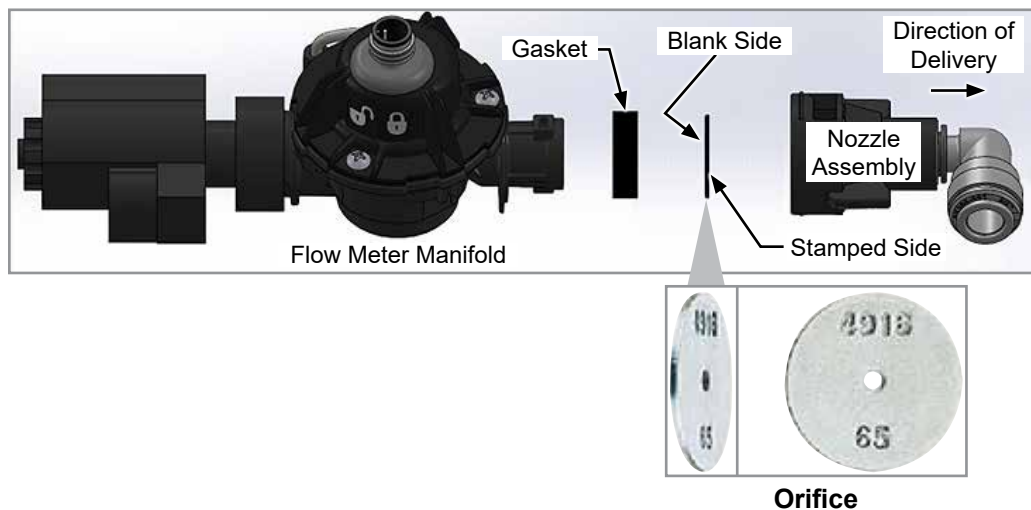

**FLOW METER STRAINER AND ORIFICE CLEANING AND/OR REPLACEMENT**

Strainer

1. Rotate the nozzle assembly counterclockwise 90° and pull nozzle off.



2. Pull strainer out of flow meter and clean or replace it.

**NOTE: Reinstall a clean strainer with the flange towards the nozzle cap. Refer to table to ensure the correct strainer is chosen for the orifice selected.**

Orifice Size	Strainer Mesh Size	Part Number	Color
0.015 and Below	200	G10943201	Pink
0.016 - 0.039	100	G10943101	Green
0.040-0.070	50	GD27290	Blue
0.072 and Larger	---	---	---



Orifice

1. Rotate the nozzle assembly counterclockwise 90° and pull nozzle off.

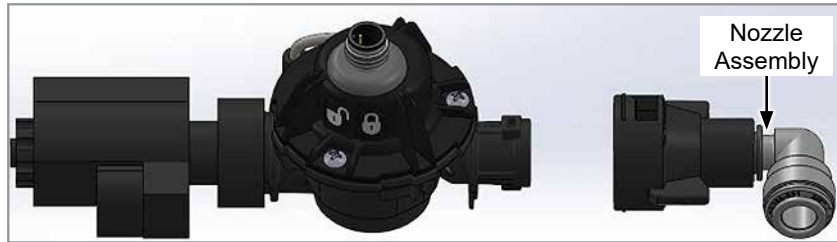

2. Remove gasket with orifice currently installed.
3. Remove orifice from gasket.

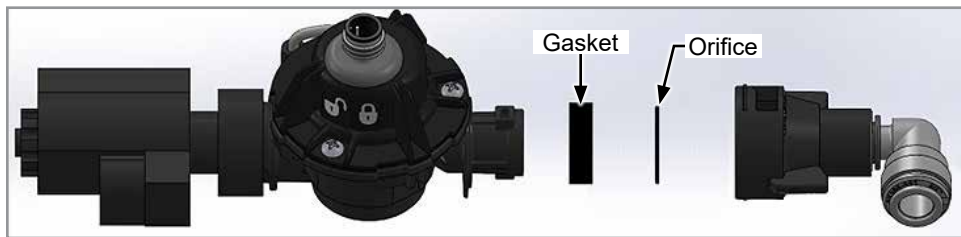

**NOTE: Orifices must be installed correctly. Install orifice with the blank side towards the flow meter manifold and the stamped side facing nozzle assembly (pointing downstream toward the direction of delivery).**

**NOTE: Orifice is installed in center groove of gasket.**

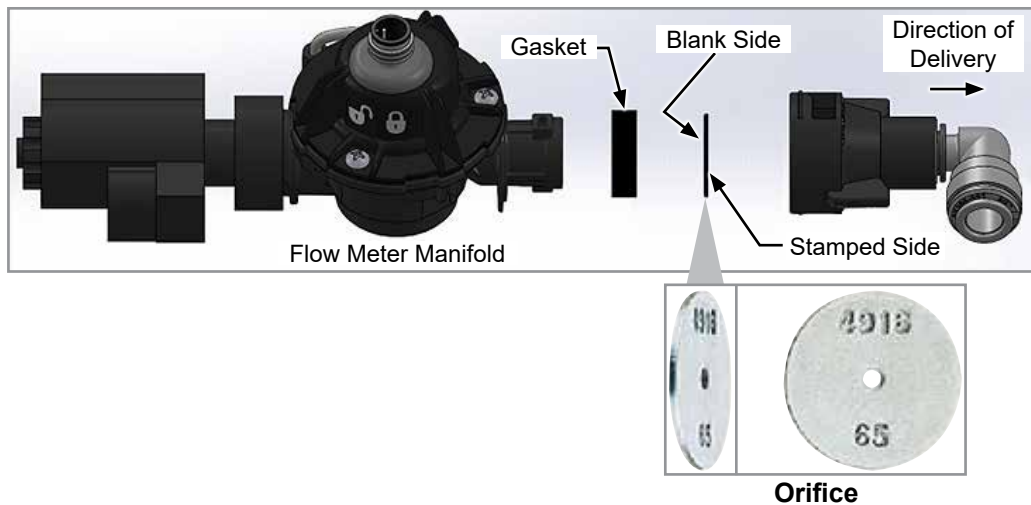

**ORIFICE CONFIGURATION RATES**

How to select an orifice configuration (using Orifice Look Up Chart below):

- Find the closest listed Gallons per Acre [GPA] value and its group of rows.

Identify the slowest and highest planting speed that will be used. Follow those rows over to corresponding row spacing being used, this equals Gallons per Minute [GPM].

- For a more accurate GPM, use this formula: 
$$GPM = \frac{(Row\ Spacing \times MPH \times GPA)}{5940}$$

- Take the low and high GPMs, trace them vertically on Orifice Rate Chart. Whichever bar best covers that range, this is the configuration that should be used.

**NOTE: If GPM is high enough, the jet orifice may have to be removed, see "[Row Flow meter Jet Orifice Removal](#)" on page 4-16.**

**ORIFICE LOOK UP CHART**

GPA	MPH	30in GPM	20in GPM	15in GPM	GPA	MPH	30in GPM	20in GPM	15in GPM	GPA	MPH	30in GPM	20in GPM	15in GPM	GPA	MPH	30in GPM	20in GPM	15in GPM	GPA	MPH	30in GPM	20in GPM	15in GPM	GPM	MPH	GPA	
2	4	0.04	0.03	0.02	7	4	0.14	0.09	0.07	14	4	0.28	0.19	0.14	22	4	0.44	0.30	0.22									
2	6	0.06	0.04	0.03	7	6	0.21	0.14	0.11	14	6	0.42	0.28	0.21	22	6	0.67	0.44	0.33									
2	8	0.08	0.05	0.04	7	8	0.28	0.19	0.14	14	8	0.57	0.38	0.28	22	8	0.89	0.59	0.44									
2	10	0.10	0.07	0.05	7	10	0.35	0.24	0.18	14	10	0.71	0.47	0.35	22	10	1.11	0.74	0.56									
2	12	0.12	0.08	0.06	7	12	0.42	0.28	0.21	14	12	0.85	0.57	0.42	22	12	1.33	0.89	0.67									
4	4	0.08	0.05	0.04	8	4	0.16	0.11	0.08	16	4	0.32	0.22	0.16	24	4	0.48	0.32	0.24									
4	6	0.12	0.08	0.06	8	6	0.24	0.16	0.12	16	6	0.48	0.32	0.24	24	6	0.73	0.48	0.36									
4	8	0.16	0.11	0.08	8	8	0.32	0.22	0.16	16	8	0.65	0.43	0.32	24	8	0.97	0.65	0.48									
4	10	0.20	0.13	0.10	8	10	0.40	0.27	0.20	16	10	0.81	0.54	0.40	24	10	1.21	0.81	0.61									
4	12	0.24	0.16	0.12	8	12	0.48	0.32	0.24	16	12	0.97	0.65	0.48	24	12	1.45	0.97	0.73									
5	4	0.10	0.07	0.05	10	4	0.20	0.13	0.10	18	4	0.36	0.24	0.18														
5	6	0.15	0.10	0.08	10	6	0.30	0.20	0.15	18	6	0.55	0.36	0.27														
5	8	0.20	0.13	0.10	10	8	0.40	0.27	0.20	18	8	0.73	0.48	0.36														
5	10	0.25	0.17	0.13	10	10	0.51	0.34	0.25	18	10	0.91	0.61	0.45														
5	12	0.30	0.20	0.15	10	12	0.61	0.40	0.30	18	12	1.09	0.73	0.55														
6	4	0.12	0.08	0.06	12	4	0.24	0.16	0.12	20	4	0.40	0.27	0.20														
6	6	0.18	0.12	0.09	12	6	0.36	0.24	0.18	20	6	0.61	0.40	0.30														
6	8	0.24	0.16	0.12	12	8	0.48	0.32	0.24	20	8	0.81	0.54	0.40														
6	10	0.30	0.20	0.15	12	10	0.61	0.40	0.30	20	10	1.01	0.67	0.51														
6	12	0.36	0.24	0.18	12	12	0.73	0.48	0.36	20	12	1.21	0.81	0.61														

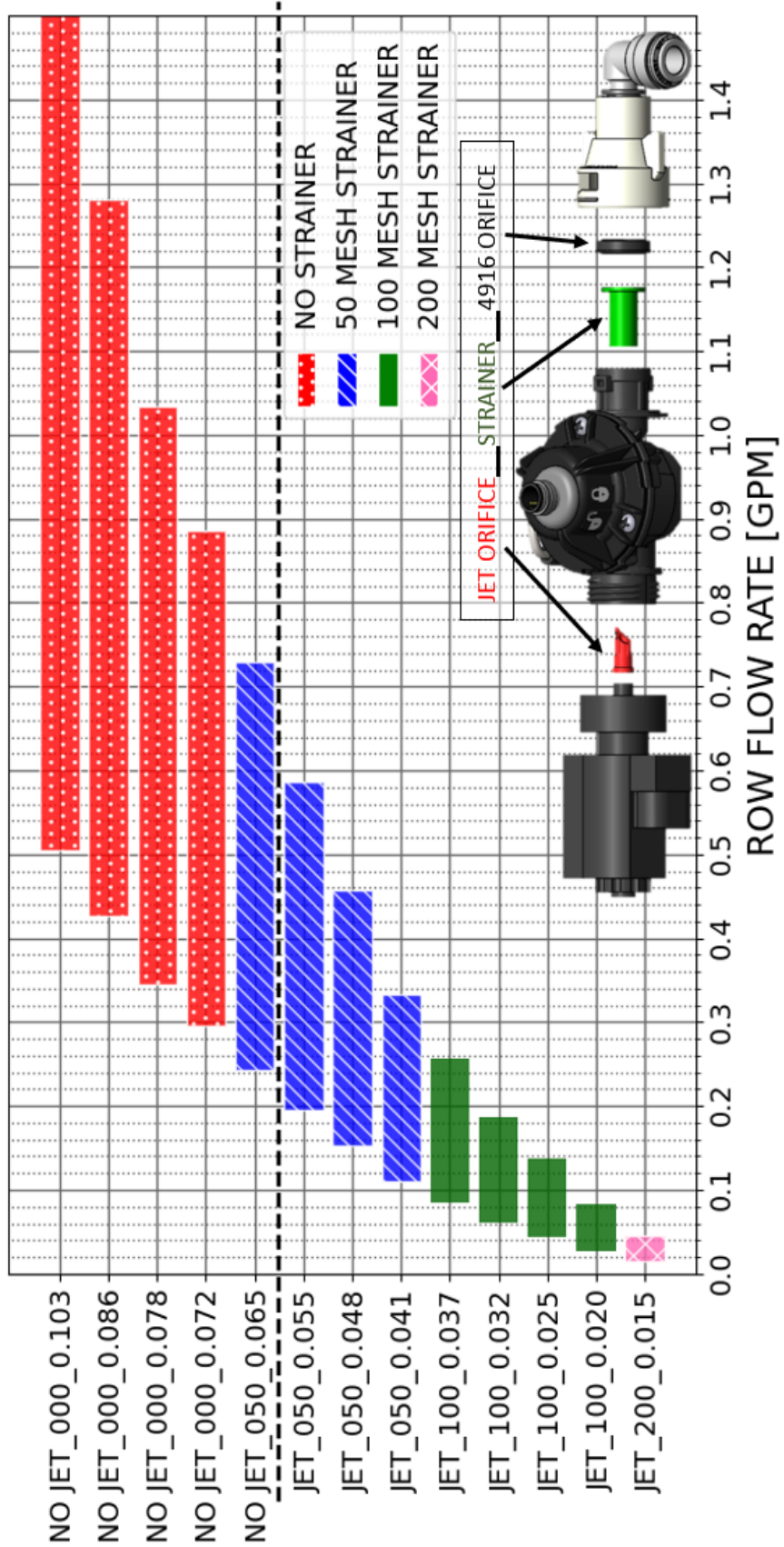

## PUMP CLEAN OUT AND STORAGE

**NOTE:** Do not let fertilizer sit in pump and system for longer than a day. Fertilizer will crystalize and cause issues with small moving parts and nozzles in the fertilizer system.

**NOTE:** Chemical solutions may become extremely corrosive if system is not cleaned out properly.

After each use, flush out circuit with clean water by running pump with clean water for a few minutes. Then drain it by operating without pressure and suck-in air by opening a ball valve on suction line or remove suction fitting until the pump runs dry.

Inspect pump and other circuit components with regularity, or at the end of the season, replacing any components which shows signs of wear.

If pump is stored for the winter in a zone with risk of frost, liquid anti-freeze should be added to the circuit, flushing water.

1. Remove as much fertilizer out of tank(s) and row unit manifolds as possible.
2. Fill tank(s) with 50-100 gallons of clean water.
3. Run system on Blue Vantage so that manual run buttons can be used to clean row unit plumbing.
4. Beginning in the middle of the planter, flushing each row unit (with manual run button) for 5-10 seconds each. Row unit is clean once mostly clear water is seen. After every row has been cleaned out, repeat process on each row for an additional 2-3 seconds per row. This will clean out the components on each row unit.
5. Clean flow meters on every row. See ["Row Flow meter Cleanout" on page 4-15](#)
6. Cleanout complete, complete remaining steps for winterization.
7. Remove suction hose barb. NOTE: Suction valve will be closed when not in a Blue Vantage task.
8. Remove the discharge manifold drain plug from the pump.

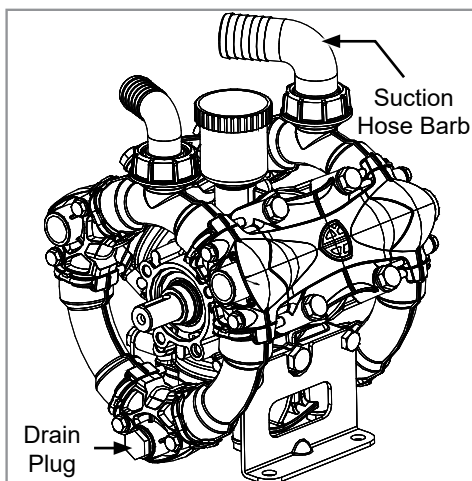

Diaphragm Pump - Model Number AR120

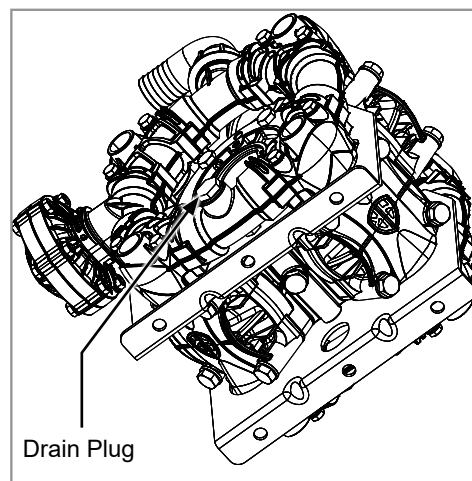

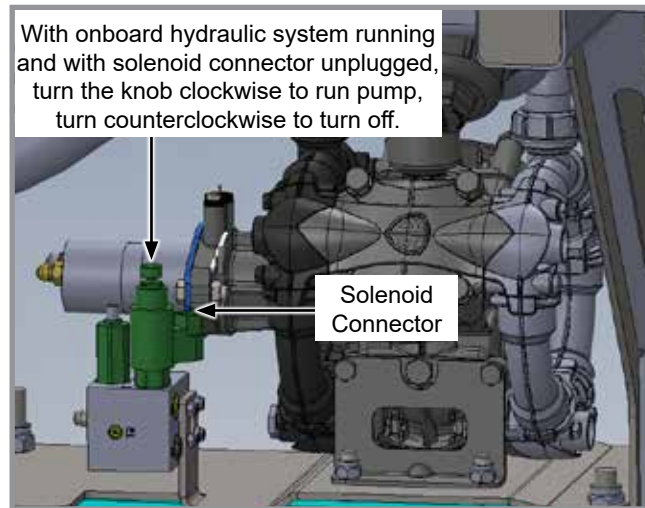

Diaphragm Pump - Model Number AR160

9. Turn the pump over by hand (or with the motor) for 15-20 seconds to remove any fluid in the manifolds and heads.



10. Reinstall drain plug.
11. Add a 50:50 mix of water and RV antifreeze through the same inlet access port
12. Run the pump for a few seconds to distribute the mix through the manifolds and heads.
13. Fill onboard fertilizer tank with small amount of liquid anti-freeze for winter storage.

 <b>WARNING</b>	<p><b>Antifreeze can cause death or serious injury to persons, animals, and plants or seriously damage soil, equipment, or property. Read and follow all chemical manufacturers labels and instructions.</b></p>
	

14. Run system so liquid anti-freeze distributes through the manifolds and flow meter on every row unit. Use manual run buttons so antifreeze comes out of every row unit.

<b>NOTICE</b>	<p><b>Catch any antifreeze in a container and dispose in a safe manner, to appropriate waste disposal facility, in accordance with local/regional regulations.</b></p>
---------------	--

15. Wash any excess fertilizer or winterizing fluid off planter before putting into storage.

---

**IN FURROW**

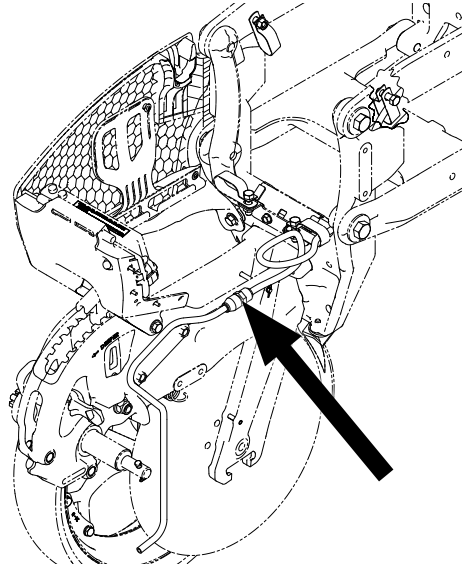

In Furrow is available for in-line installation to ensure equal distribution of product at low rates and siphon protection for field turns.

## AUXILIARY PLUMBING FOR LIQUID FERTILIZER

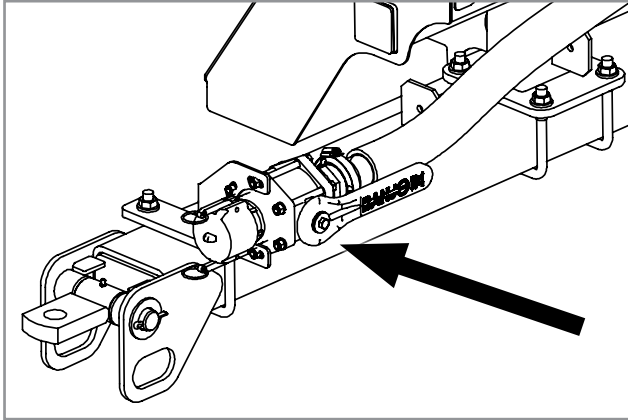

Rear Trailer Hitch Auxiliary Plumbing

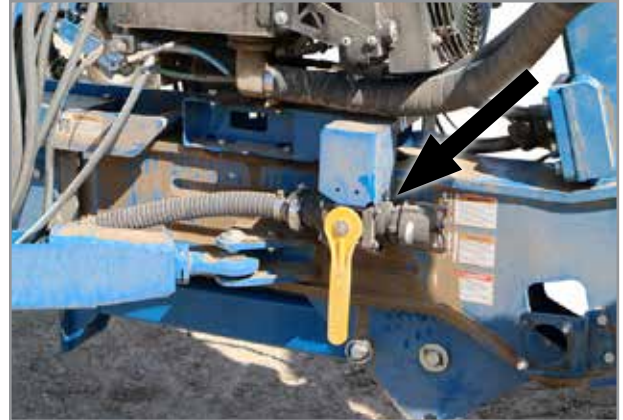

Front Hitch Auxiliary Plumbing

Rear trailer hitch is used to tow a 3 or 4 wheel wagon behind planter. Hitch height during field operation and transport is 15". Hitch height will raise to approximately 42" when planter is lifted.

### NOTICE

Rear trailer hitch is designed for use with diaphragm pump only. Maximum allowable hitch weight is 200 lb (90.71kg). Do not exceed 6,000 lb (2,721.55 kg) gross towing weight or the equivalent of a loaded 500 gal (1,892.7 L) tank and running gear or equipment can be damaged.

**NOTE:** Periodically check feed hose for kinks to prevent restricted delivery rate.

Adjust rear trailer hitch length by loosening the  $\frac{5}{8}$ " set screws at rear of outer tube, removing 1" x  $8\frac{1}{2}$ " bolt at center of hitch, and sliding hitch in or out to one of 4 sets of adjustment holes. Reinstall and tighten hardware.

Front Hitch auxiliary plumbing is used to connect to tractor tanks.

Auxiliary plumbing (front or rear) pulls fluid from an auxiliary source with the onboard pump, then is applied with the fertilizer system and controlled with Blue Vantage controls.

Auxiliary ValvesFront Auxiliary Valve

Located on the front hitch. This valve should be opened when hooked to a tractor tank for the planting season, it can remain open all season while hooked to tractor tank(s). Before disconnecting planter from tractor, close this valve and disconnect fluid supply from tractor tanks.

**NOTE: Always make sure there is enough slack between the tractor and planter, when making turns and lifting and lowering the planter.**

Rear Auxiliary Valve

There is a second valve that will be located by on board bulk fill valve in the rear of the planter so you can pull from a tank on a trailer if you have the trailer hitch. This is not available on 20 inch planters because there is no rear trailer hitch option available on 20 inch planters.

**NOTE: Always make sure there is enough slack between the trailer and planter, when making turns and lifting and lowering the planter.**

**NOTE: Switch two valves under onboard tank and the valve at the point of auxiliary hook up either at the front of the planter for tractor tank or on the rear hitch of the planter for trailer tank.**



**FERTILIZER PUMP TROUBLESHOOTING**

<b>PROBLEM</b>	<b>CAUSE</b>	<b>SOLUTION</b>
Pump does not prime.	Air being sucked in from suction line.	Check suction line connections and inspect it for damage.
	One or more valves not properly sealing.	Check the valves and replace them (if necessary).
Pump does not reach rated working pressure.	One or more valves not properly sealing.	Check the valves and replace them (if necessary).
	Nozzles worn or not correct diameter.	Check nozzles and replace them (if necessary).
	Suction filter plugged.	Clean filter.
	Presence of air pockets or collapsed suction hose.	Check suction line.
Pressure gauge needle fluctuates.	Air being sucked in from suction line.	Check suction line connections and inspect it for damages.
	One or more valves jammed.	Check the valves and replace them (if necessary).
	Pulsation damper deflated (60' only).	Inflate pulsation damper to 15 psi.
Delivery flow is irregular.	Pulsation damper deflated (60' only).	Inflate pulsation damper to 15 psi.
Flow rate falls and pump is noisy.	Oil level in tank has dropped.	Top off oil to correct level.
Excessive noise and vibrations and fall in performance.	Cavitation.	Clean filter.
	Suction hose collapsed.	Check suction line and eliminate any restriction found.
	Suction filter plugged.	Clean filter or change filter cartridge.
	Suction vertical drop too high.	Reduce suction vertical drop.
Oil disappears from tank (after oil topped off)	One or more diaphragms are ruptured.	Stop pump immediately and replace diaphragm.
Oil going into tank changing to milky white color.	Oil/water emulsion into tank. One or more diaphragms are ruptured.	Stop pump immediately and replace diaphragm.

**FERTILIZER SYSTEM TROUBLESHOOTING**

<b>PROBLEM</b>	<b>CAUSE</b>	<b>SOLUTION</b>
Fertilizer flow not detected.	Plugged orifice.	Clean debris from orifice.
	Row shutoff valve plugged.	Clean debris from shutoff valve, replace if necessary.
	Flow meter plugged.	Open cover and check for debris.
Fertilizer flow unexpected.	Row shutoff valve stuck open.	Clean debris from shutoff valve, replace if necessary.
Fertilizer rail pressure high.	Improper orifice selection.	Refer to orifice charts.
	Check valve on agitation line installed backwards.	Turn valve around so flow arrow points out of regulator.
No fluid detected.	Fluid inlet sensor does not have power.	Check wiring harness.
	No fluid at pump.	Clean suction strainer regularly. Ensure fluid is in tanks, prime pump.
Fertilizer Off - rail sensor error.	Rail pressure sensor is not being powered properly.	Check wiring harness.
	Rail pressure sensor is damaged.	Replace pressure sensor.
Fertilizer Off - suction sensor error.	Suction pressure sensor is not being powered properly.	Check wiring harness.
	Suction pressure sensor is damaged.	Replace pressure sensor.
Fertilizer off - high suction pressure.	Suction pressure has exceeded -7 PSI.	Clean suction strainer regularly.
	Suction strainer is clogged.	
	Suction hose is kinked/damaged.	Replace hose.
	Electronic ball valve is not opening.	Check wiring harness and ball valve.
Pump RPM not detected.	RPM sensor is not being powered properly.	Check wiring harness.
Pump will not run or turn on.	No hydraulic flow to motor.	Send hydraulic flow to pump.
	No fertilizer control enabled.	Blue Vantage must be on and in a fertilizer task.
Pump will not prime or pump.	Plugged suction strainer.	Clean strainers regularly.
	Suction ball valve not opening.	Check wiring harness and ball valve.
Unable to achieve rate.	Plugged row strainers or orifice.	Inspect and clean row flow components.
	Plugged pressure strainer.	Clean strainers regularly.
Flow rate does not read properly below 1.5 GPM.	Lower small system flow meter installed backwards.	Ensure lower small system flow meter is in correct orientation (check arrow direction).
	Lower small system flow meter does not have power/reading incorrectly.	Check wiring harness.
Pump will not pull from auxiliary tank.	Plugged suction strainer.	Clean strainers regularly.
	Air leak in auxiliary hose.	Tighten any loose connections.
Analog pressure gauge needle bouncing.	Inline orifice not installed in hose.	Add orifice to system before gauge.

**NOTICE**

Disconnect all electronic monitor and control modules prior to making any repairs or modifications to the planter or mounted attachments. Failure to do so will result in permanent damage to sensitive electronic components and could void your warranty.

**NOTICE**

Do not pressure wash any electronic modules directly. Direct pressure washing will result in permanent damage to sensitive electronic components and could void your warranty.

**LUBRICATION**

Following pages show locations of all lubrication points. Proper lubrication of moving parts helps ensure efficient operation of your Kinze planter and prolongs the life of friction producing parts.

**LUBRICATION SYMBOLS**

Lubricate at frequency indicated with SAE multipurpose grease.



Lubricate at frequency indicated with high quality SAE 10 weight oil or spray lubricant.

**WHEEL BEARINGS**

All drive, transport, and marker hub wheel bearings should be repacked annually and checked for wear.

1. Raise wheel off ground.
2. Check for bearing endplay by moving wheel side to side.
3. Rotate wheel to check for bearing roughness. If bearings sound rough, remove hub and inspect bearings.

**NOTE:** To repack wheel hubs, follow procedure outlined for wheel bearing replacement in this section except bearings and bearing cups are reused.

## BUSHINGS

Lubricate bushings at frequency indicated.

Check each bolt for proper torque. If bolt is loose, removed it and inspect bushing for cracks and wear. Replace bushing if necessary. Use **only hardened flat washers**. Replace damaged flat washers with proper part. Torque hardware to 130 ft-lb (176.2 N-m).

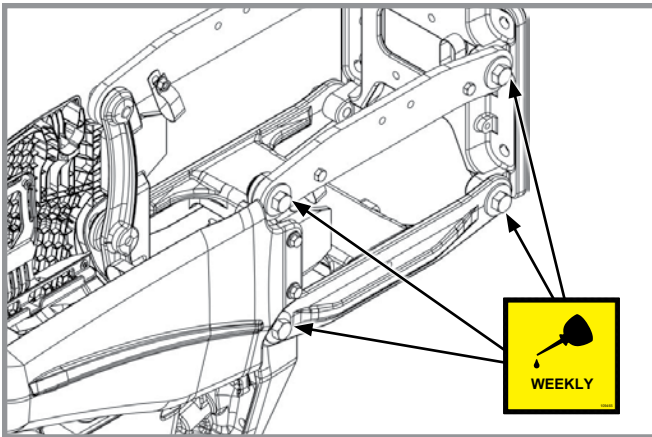

**Pull Row Unit Parallel Linkages  
8 Per Row**



**Closing Wheel Arm (2 Per Row)**

**GREASE FITTINGS**



**WARNING**

Uncontrolled movement of equipment can cause loss of control and could result in death, serious injury, or damage to property and equipment. Install all safety lockup devices before transporting equipment.

Parts equipped with grease fittings should be lubricated at frequency indicated with an SAE multipurpose grease. Clean fitting thoroughly before using grease gun. Frequency of lubrication recommended is based on normal operating conditions. Severe or unusual conditions may require more frequent attention.

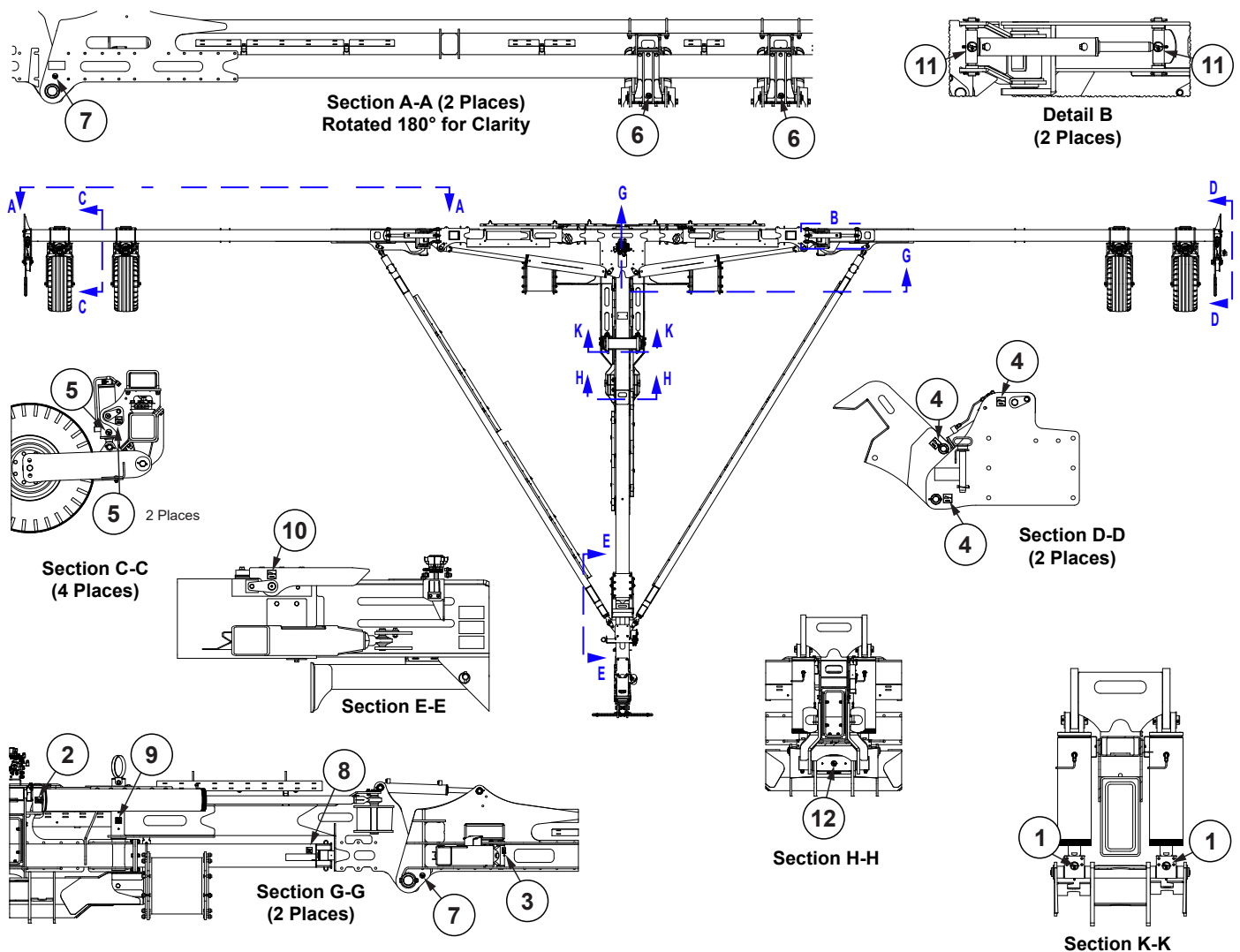

**NOTE:** Shown with no row units or row markers.

**NOTE:** Numbers on illustration above correspond to photos on following pages showing lubrication frequencies.

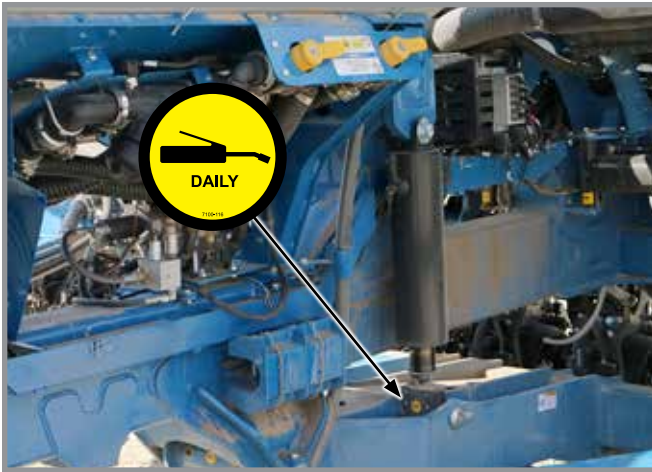

1. Lift Cylinders, 2 per machine  
1 fitting per cylinder



2. Wing Fold cylinders, 4 per machine  
2 fittings per cylinder (one each end)



3. Draft Link, 2 per machine  
1 fitting per link



4. Wing Latch cylinders, 4 per machine  
2 fittings per cylinder (one each end)

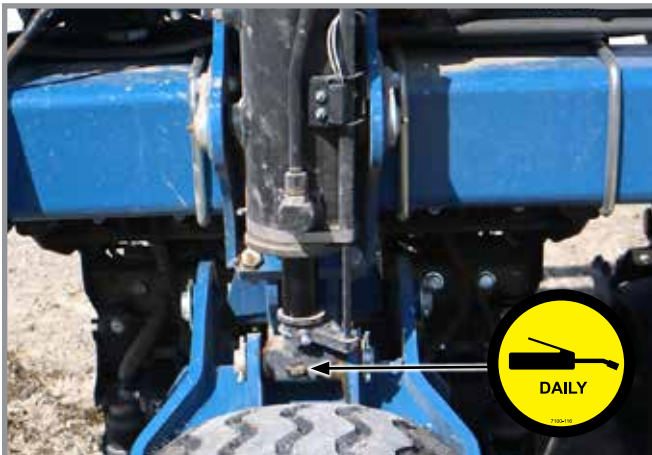

5. Lift Cylinders, 12 per machine  
3 fittings per cylinder



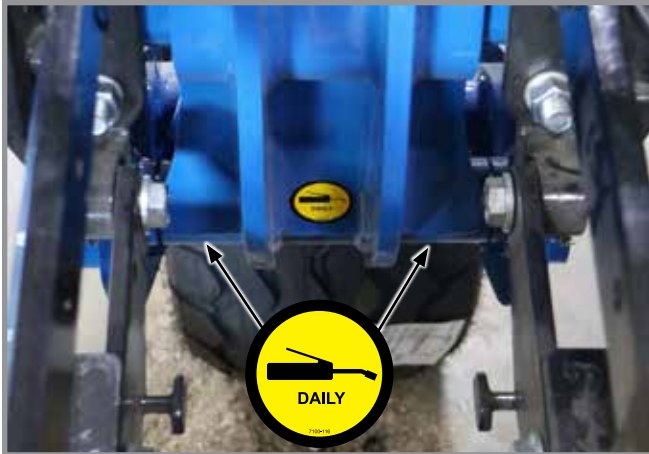

6. Wheel modules, 4 per machine  
2 fittings per module

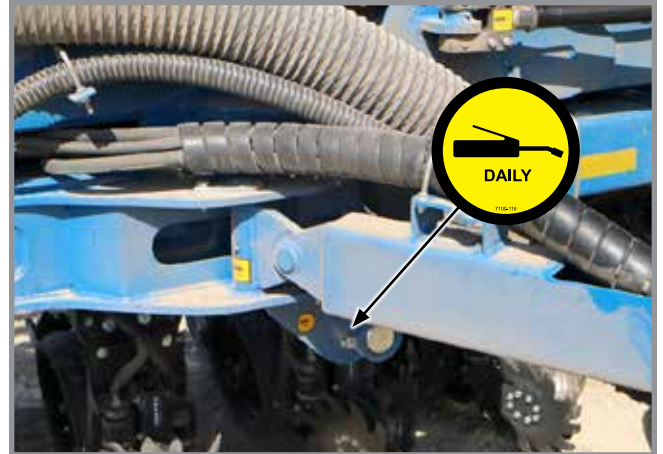

7. Wing pivot, 2 per machine  
1 fitting per pivot



8. Stub Wing Roller, 2 per machine  
1 fitting per roller

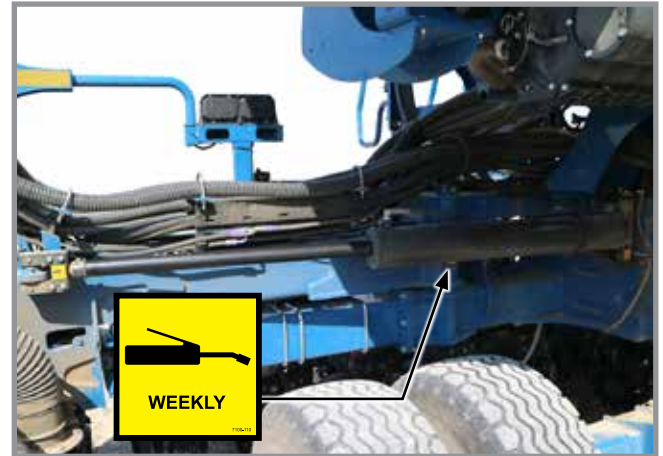

9. Wing Fold Pivot, 2 per machine  
1 fitting per wing

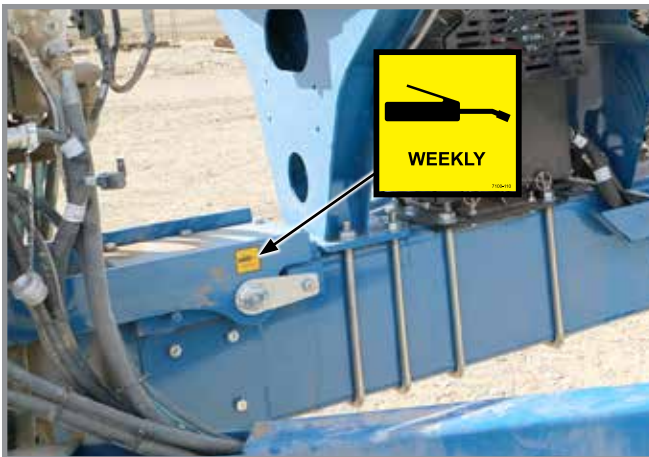

10. Hitch Latch, 2 fittings per machine

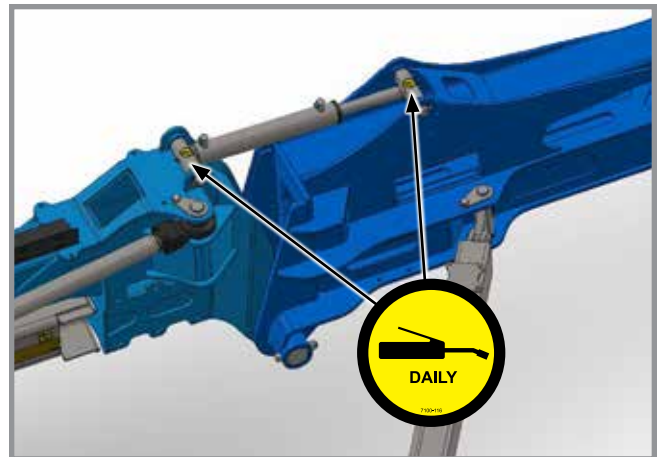

11. Wing Down Pressure Cylinders, 2 per machine  
2 fittings per cylinder

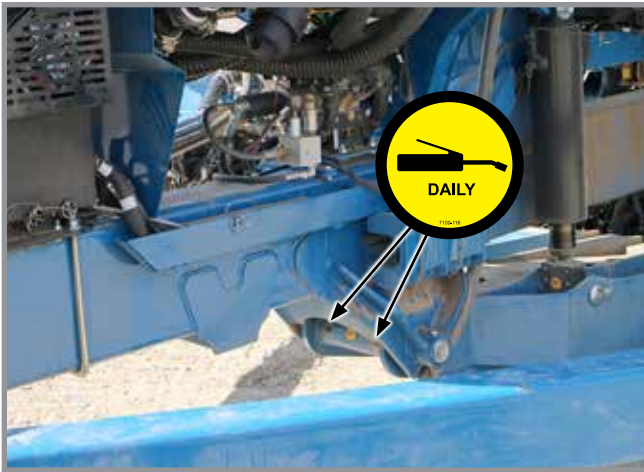

12. Axle Pivot, 2 per machine

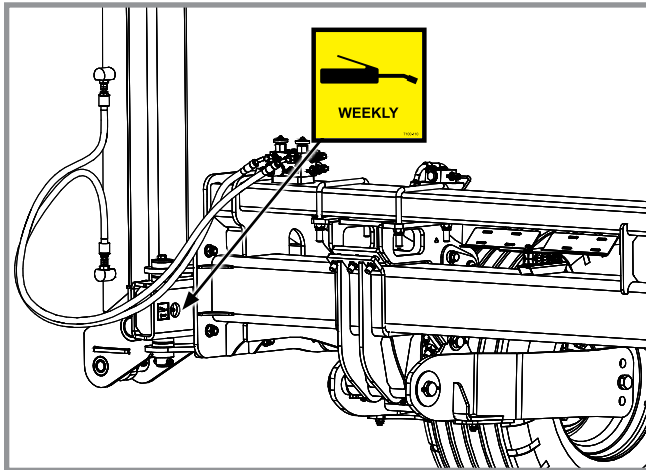

24 Row 20"

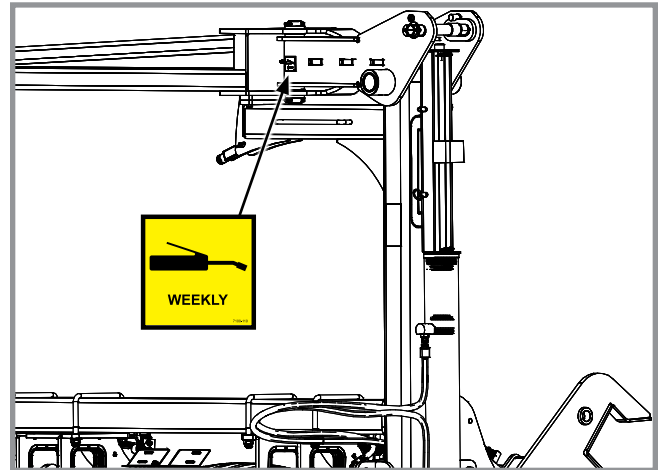

24 Row 30" / 36 Row 20"

Row Markers

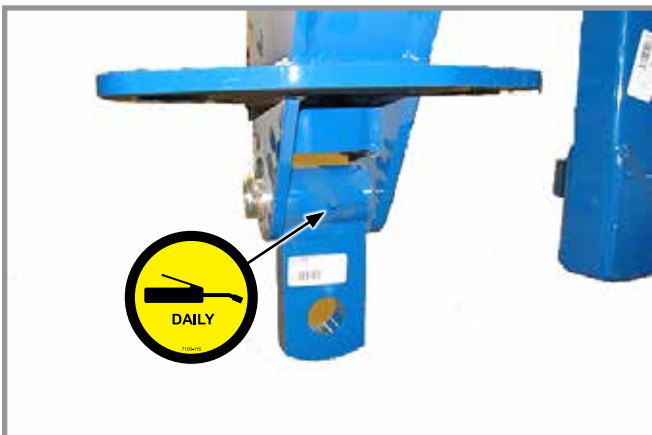

Trailer Hitch  
1 fitting



Drawbar Hitch  
1 fitting



## PTO SHAFT COUPLING

Clean and grease PTO shaft coupling each time pump is installed.

Apply coating of high-speed industrial coupling grease, such as Chevron® Coupling Grease meeting AGMA CG-1 and CG-2 Standards to extend shaft spline life.

Apply chain lubricant twice daily to chain coupler.

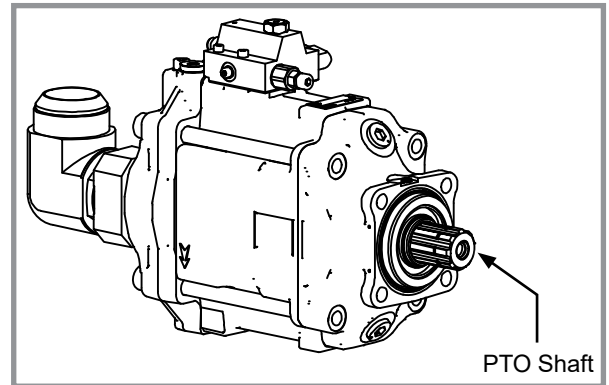

**Two-section PTO Hydraulic Pump**

**MOUNTING BOLTS AND HARDWARE**

Before operating planter for the first time, check all hardware is tight. Check all hardware again after first 50 hours of operation and beginning of each planting season.

All hardware used on the Kinze planter is Grade 5 (high strength) unless otherwise noted. Grade 5 cap screws are marked with three radial lines on the head. Hardware must be replaced with equal size, strength, and thread type.

**WARNING**

**Loose transport wheel lug bolts can result in wheel separation from planter and result in death, serious injury, and damage to property and equipment. Check transport wheel lug nut torque before operating planter for the first time and periodically thereafter.**

**NOTICE**

**Over-tightening hardware can reduce its shock load capacity and cause equipment failure.**

**TORQUE VALUES CHART - PLATED HARDWARE**

Diameter	Grade 2 (No marks)		Grade 5 (3 marks)		Grade 8 (6 marks)	
	Coarse	Fine	Coarse	Fine	Coarse	Fine
1/4"	50 in-lb	56 in-lb	76 in-lb	87 in-lb	9 ft-lb (12 N-m)	10 ft-lb (14 N-m)
5/16"	8 ft-lb (11 N-m)	9 ft-lb (12 N-m)	13 ft-lb (18 N-m)	14 ft-lb (19 N-m)	18 ft-lb (24 N-m)	20 ft-lb (27 N-m)
3/8"	15 ft-lb (20 N-m)	17 ft-lb (23 N-m)	23 ft-lb (31 N-m)	26 ft-lb (35 N-m)	33 ft-lb (45 N-m)	37 ft-lb (50 N-m)
7/16"	25 ft-lb (34 N-m)	27 ft-lb (37 N-m)	37 ft-lb (50 N-m)	41 ft-lb (56 N-m)	52 ft-lb (71 N-m)	58 ft-lb (79 N-m)
1/2"	35 ft-lb (48 N-m)	40 ft-lb (54 N-m)	57 ft-lb (77 N-m)	64 ft-lb (87 N-m)	80 ft-lb (108 N-m)	90 ft-lb (122 N-m)
9/16"	50 ft-lb (68 N-m)	60 ft-lb (81 N-m)	80 ft-lb (108 N-m)	90 ft-lb (122 N-m)	115 ft-lb (156 N-m)	130 ft-lb (176 N-m)
5/8"	70 ft-lb (95 N-m)	80 ft-lb (108 N-m)	110 ft-lb (149 N-m)	125 ft-lb (169 N-m)	160 ft-lb (217 N-m)	180 ft-lb (244 N-m)
3/4"	130 ft-lb (176 N-m)	145 ft-lb (197 N-m)	200 ft-lb (271 N-m)	220 ft-lb (298 N-m)	280 ft-lb (380 N-m)	315 ft-lb (427 N-m)
7/8"	125 ft-lb (169 N-m)	140 ft-lb (190 N-m)	320 ft-lb (434 N-m)	350 ft-lb (475 N-m)	450 ft-lb (610 N-m)	500 ft-lb (678 N-m)
1"	190 ft-lb (258 N-m)	205 ft-lb (278 N-m)	480 ft-lb (651 N-m)	530 ft-lb (719 N-m)	675 ft-lb (915 N-m)	750 ft-lb (1017 N-m)
1 1/8"	265 ft-lb (359 N-m)	300 ft-lb (407 N-m)	600 ft-lb (814 N-m)	670 ft-lb (908 N-m)	960 ft-lb (1302 N-m)	1075 ft-lb (1458 N-m)
1 1/4"	375 ft-lb (508 N-m)	415 ft-lb (563 N-m)	840 ft-lb (1139 N-m)	930 ft-lb (1261 N-m)	1360 ft-lb (1844 N-m)	1500 ft-lb (2034 N-m)
1 3/8"	490 ft-lb (664 N-m)	560 ft-lb (759 N-m)	1100 ft-lb (1491 N-m)	1250 ft-lb (1695 N-m)	1780 ft-lb (2413 N-m)	2030 ft-lb (2752 N-m)
1 1/2"	650 ft-lb (881 N-m)	730 ft-lb (990 N-m)	1450 ft-lb (1966 N-m)	1650 ft-lb (2237 N-m)	2307 ft-lb (3128 N-m)	2670 ft-lb (3620 N-m)

**NOTE: Torque unplated hardware and bolts with lock nuts approximately 1/3 higher than above values. Torque bolts lubricated prior to installation to 70% of value shown in chart.**

**SPECIAL TORQUE VALUES AND INSTRUCTIONS**

Row unit parallel linkage bushing hardware	190 ft-lb (258 N-m)
5/8" No till coulter spindle hardware	120 ft-lb (162 N-m)
Row Unit Disc Opener Blade Bolt**	125 ft-lb (169 N-m) **Left hand side is left hand thread.
5/8" - 18 Wheel Lug Nuts and Lug Bolts	200 ft-lb (271 N-m)
9/16" - 18 Wheel Lug Nuts and Lug Bolts	125 ft-lb (169 N-m)
Row Unit Support (Face Plate)	115 ft-lb (156 N-m)
Notched Single Disc Opener - 3/4" L-bolts	160 ft-lb (217 N-m)
Notched Single Disc Opener - 5/8" Hex Head Cap Screws	90 ft-lb (122 N-m)
Notched Single Disc Opener - 3/4" Hex Set Screws	160 ft-lb (217 N-m)
Gauge Wheel Spindle	1000 ft-lb (1356 N-m)
Master Cylinder - 1/2"-13 Hex Socket Head Cap Screws (24 Row 20" Only)	125 ft-lb (169 N-m)

**CYLINDER ROD PISTON RETAINING NUT TORQUE CHART**

	Non-Nylock Nut	Nylock Nut
1/2"-20	55-70 ft-lb (75-95 N-m)	45-55 ft-lb (61-75 N-m)
3/4"-16	115-125 ft-lb (156-169 N-m)	100-115 ft-lb (136-156 N-m)
7/8"-14	150-180 ft-lb (203-244 N-m)	130-150 ft-lb (176-203 N-m)
1"-14	275-330 ft-lb (373-447 N-m)	250-275 ft-lb (339-373 ft-lb)
1 1/8"-12	300-375 ft-lb (407-508 N-m)	275-300 ft-lb (373-407 N-m)
1 1/4"-12	300-375 ft-lb (407-508 N-m)	275-300 ft-lb (373-407 N-m)

**TORQUE VALUES- ALUMINUM**

Diameter	Torque Value
1/8"	180-220 in-lb
3/8"	350-380 in-lb
1/2"	350-400 in-lb
3/4"	350-400 in-lb

**NOTE: Use these torque values with pneumatic down pressure components.**

**TORQUE VALUES - TRUE DEPTH HYDRAULIC DOWN FORCE**

Cylinder Head to Body:	70 ft-lb
Cylinder Piston to Rod:	50 ft-lb
Row Unit Valve Cartridge to Line Body:	30 ft-lb
Row Unit Valve Solenoid to Valve:	4-6 ft-lb

**NOTE:**

1. A 6-Pt Socket must be used to torque the cylinder head to the body.
2. Apply blue threadlocker to cylinder head threads when reassembling.
3. Replace piston to rod locknut with equivalent 7/16"-20 locknut before reassembling.

**ETHERNET CABLE TORQUE VALUES**

Ethernet Cables	 <p>Torque Driver (P/N: GA26173)</p>	0.7 N-m
-----------------	---	---------

## TIRE PRESSURE

 **WARNING**

Explosive separation of rim and tire parts can cause death or serious injury. Overinflation, rim and tire servicing, improper use of rims and tires, or worn or improperly maintained tires could result in a tire explosion.



- Maintain proper tire pressure. Inflating a tire above or below the recommended pressure can cause tire damage.
- Mount tires only by properly trained personnel using proper equipment.
- Replace tires with cuts or bubbles. Replace damaged rims. Replace missing lug bolts and nuts.
- Do not weld or heat wheel assembly. Heating increases tire pressure.

## TRANSPORT TIRES

 **WARNING**

Overinflation of tires can result in explosive separation of rim and tire and cause death or serious injury. Different size rims are designed for different tire pressures. Inflate to correct pressure for specific rim size.



**INFLATION SPECIFICATIONS**



**Tire Locations (L.H. shown)**

1. Torque transport wheel ¾"- 16 lug nuts to:  
 24 Row 30" / 36 Row 20" . . . . . 315 ft-lb (427 N-m)  
 24 Row 20" . . . . . 450 ft-lb (610 N-m)
2. Torque wing wheel ⅝"-18 lug nuts to 200 ft-lb (271 N-m).
3. Inflate tires to the following specifications:

Transport Tire Size (4)	445/50R 22.5	440/55R18
Transport Tire Pressure	81 PSI	73 PSI
Wing (Field) Tire Size	380/55R 16.5 (4)	380/55R 16.5 (2)
Wing (Field) Tire Pressure	65 PSI	65 PSI
Marker Arm Tire Size (2)	16" x 6½" x 8"	N/A
Marker Arm Tire Pressure	14 PSI	N/A

4. Lubricate planter and row units per lubrication information in this manual.

## TRUE RATE METER MAINTENANCE

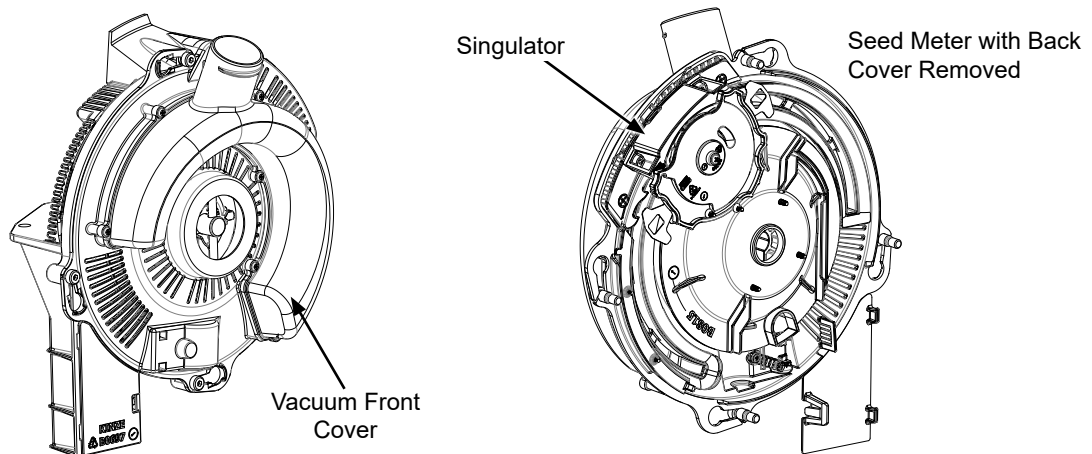

Before each planting season inspect seed discs and singulator and clean or replace as needed.

Use clean, high quality seed for maximum meter accuracy. Damaged or cracked seed, hulls, and foreign material may become lodged in seed disc orifices and greatly reduce meter accuracy.

Inspect and clean seed discs daily checking for any buildup of foreign material and blocked orifices. If seed disc orifices are plugged frequently with seed remnants, clean out brush with ball-type ejector (if applicable) may need to be replaced. Clean seed disc by washing it with soap and water. Dry thoroughly.

Inspect singulator blades and guide for wear after every 80 ha per row of operation. If adjustment of singulator blade does not affect meter performance or if blades appear worn, singulator blade may need to be replaced.

Replace seed disc or vacuum seal if abnormally high vacuum is required or if consistent operation cannot be achieved. See ["Preparation for Storage" on page 5-38](#) for additional Vacuum Seed Metering System maintenance.

**NOTE: Remove seed discs from meters for annual storage and store them vertically on a dowel or pipe.**

## TRUE RATE SEED METER CLEANOUT

**NOTE: Use of damaged seed or seed containing foreign material will cause plugging of seed cell orifices and require more frequent seed meter cleanout to prevent underplanting.**

Thorough seed meter cleanout is important to maintain genetic purity.

1. Disengage seed drive and remove seed hopper and meter.
2. Dump seed from right rear corner of hopper into a container.
3. Lay hopper on its right side. Push release button and rotate seed meter vacuum cover clockwise to align keyhole slots with bolt heads. Lift off cover.
4. Rotate seed disc hub clockwise to unlock and remove seed disc.
5. Empty meter.
6. Thoroughly inspect meter to ensure all seed is removed.
7. Replace seed disc. Install vacuum cover.

**NOTE: See ["Preparation for Storage" on page 5-38](#) to prepare seed meters and seed delivery tubes for storage.**

**VACUUM MANIFOLD MAINTENANCE**

Dust accumulates in manifolds and hoses during normal operation. Clean manifolds annually. Abnormally dusty planting conditions may require more frequent cleaning.

1. Remove vacuum hose from each seed meter.
2. Operate vacuum fan at full hydraulic flow from tractor for two minutes to clear manifolds, hoses, and fittings of dust and debris.
3. Shut down fan and replace hoses.

**TRUE SPEED SEED METER MAINTENANCE**

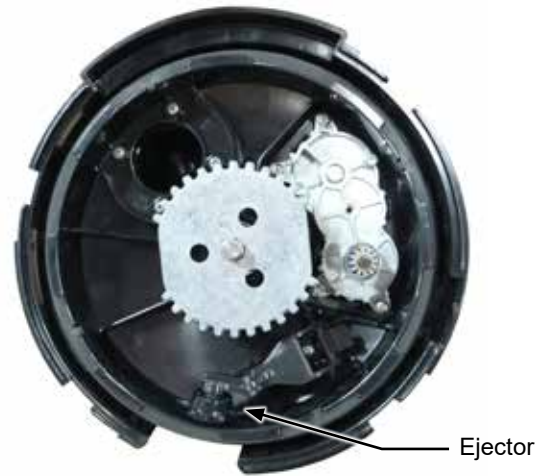
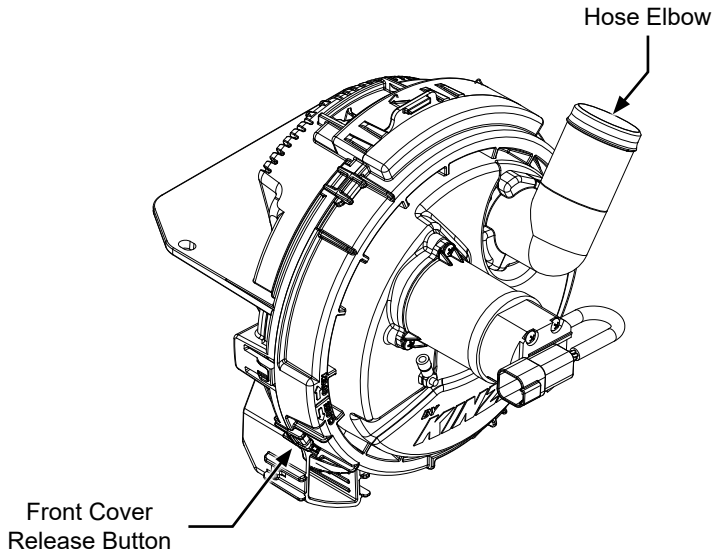

**Seed Meter With Back Cover Removed**

Before each planting season inspect seed discs and Singulator and clean or replace as needed.

Use clean, high quality seed for maximum meter accuracy. Damaged or cracked seed, hulls, and foreign material may become lodged in seed disc orifices and greatly reduce meter accuracy.

Inspect and clean seed discs daily checking for any buildup of foreign material and blocked orifices. If seed disc orifices are plugged frequently with seed remnants, ejector wheel may need to be replaced. Clean seed disc by washing it with soap and water. Dry thoroughly.

Inspect singulator for wear after every 150 acres per row of operation. If singulation is low or inspection marks are not visible, replace singulator. Also inspect singulator brushes, if brushes are worn/frayed replace singulator. Replace singulator by 500 individual row acres.

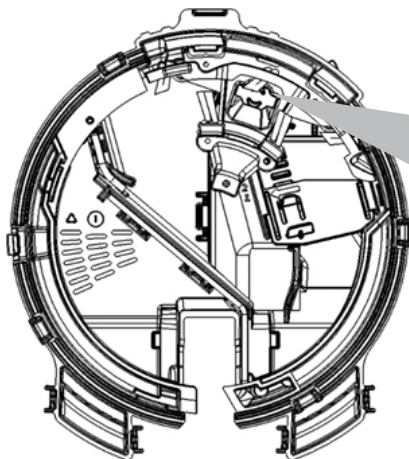

See [“True Speed Seed Meter Cleanout” on page 5-16](#) for additional Vacuum Seed Metering System maintenance.



## TRUE SPEED SEED METER CLEANOUT

**NOTE: Use of damaged seed or seed containing foreign material will cause plugging of seed cell orifices and require more frequent seed meter cleanout to prevent underplanting.**

Thorough seed meter cleanout is important to maintain genetic purity.

1. Remove bulk fill and vacuum hose fittings from meter.
2. Rotate meter into service position.
3. Unplug electrical connections and ground straps.
4. Push release button and rotate seed meter vacuum cover clockwise to align locking tabs with slots.
5. Lift meter cover off meter assembly.
5. Remove mini-hopper and dump seed into a container.
6. Inspect mini-hopper door for any remaining seed.
7. If changing crop type, change seed disc, ejector, remove or install singulator, and adjust baffle setting.
8. Reassemble meter and latch into row unit.

**NOTE: See ["Preparation for Storage" on page 5-39](#) to prepare seed meters and seed delivery tubes for storage.**

## TRUE SPEED DELIVERY TUBE MAINTENANCE

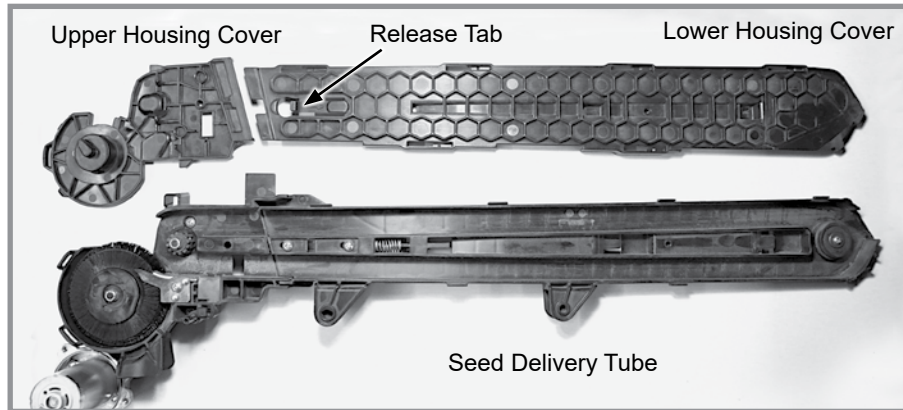

### Delivery Tube Disassembly

1. Unplug electrical connections and remove delivery tube from row unit.
2. Unscrew and remove seed sensor from delivery tube.
3. Lift release tab and slide lower housing cover downward. Lift and remove.
4. Lightly lift under the cover and slide down to release the upper housing cover.

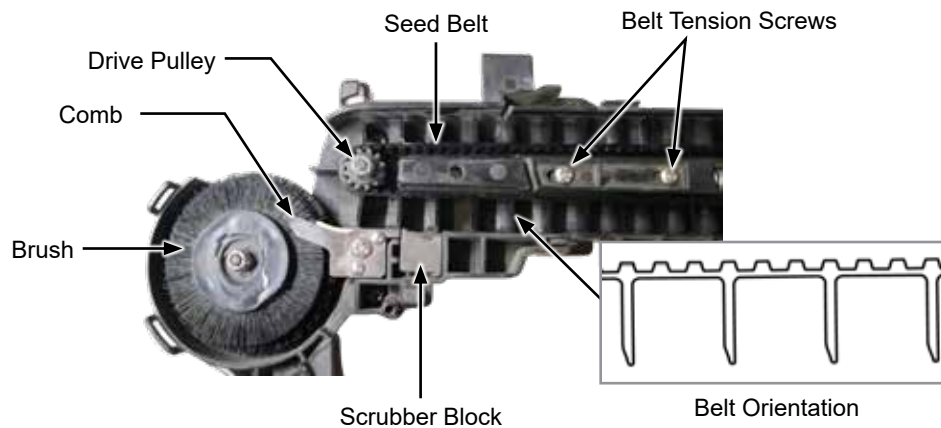

Before every planting season inspect brush wheel and seed belt. Clean or replace as needed.

Turn and reuse other side of scrubber block if one side is worn. Replace if both sides are worn.

### Belt Tension Adjustment:

Proper belt tension is necessary for long life and optimum performance of seed delivery system. Excessive belt tension can cause increased wear of upper drive pulley and under tensioned belts can cause faulty seed sensor readings.

**Belt Tensioning Procedure:**

When installing or changing parts, tensioning belt will be necessary.

1. Loosen belt tension screws.
2. Compress and loosen upper and lower halves of delivery tube to verify the two parts moves freely.
3. Manually pull upper and lower half apart and let go so the two halves are held only by tension spring.
4. Tighten belt tension screws.

**Visual Belt Tension Inspection:**

Belt tension can also be checked visually without performing the re-tension process. Manually move belt in the correct direction from the return side of the delivery tube. There should be no contact between tips of belt flights and face of delivery tube comb, ribs on scrubber block, or wall edge before seed sensor window. Under tensioned delivery tube belts will usually drag on these surfaces and can also exhibit outward spring around upper drive pulley.

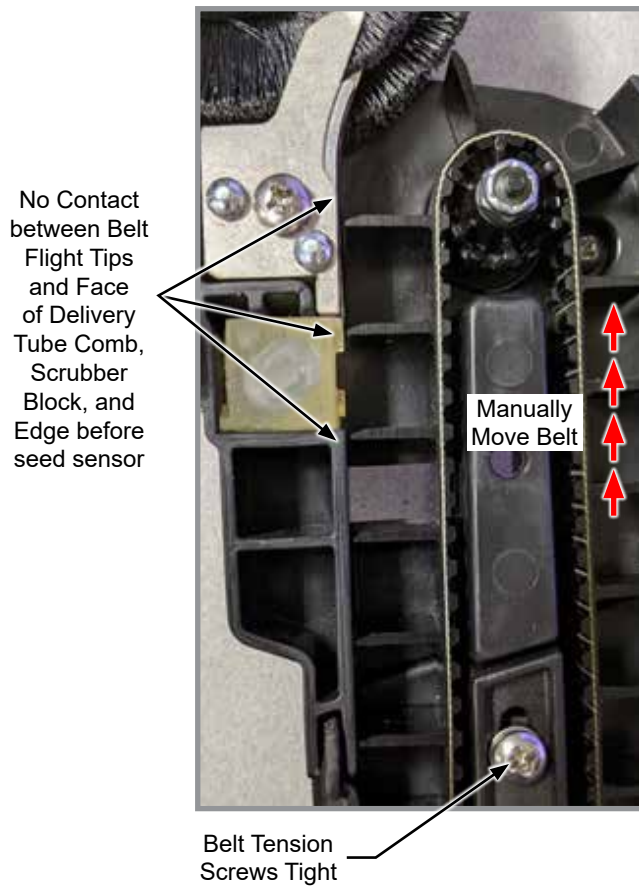
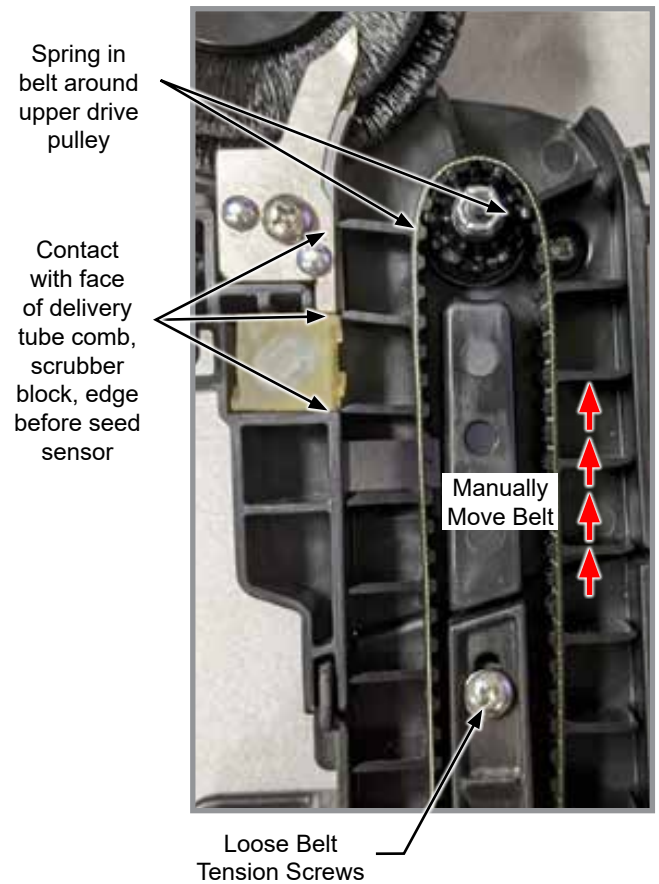
**Properly Tensioned Belt Characteristics****Under Tensioned Belt Characteristics**

**NOTE: Inspect delivery belt after first season of use and re-tension as needed.**

#### Seed Belt Replacement

1. Lift release tab and slide lower housing cover downward. Lift and remove.
2. Unscrew the seed sensor bolt with triangular head and remove seed sensor.
3. Lightly lift under the cover and slide down to release the upper housing cover.
4. Loosen belt tensioning screws.
5. Roll seed belt down and over idler pulley.
6. Replace new belt by aligning on drive pulley and rolling onto lower idler pulley.
7. Re-tension seed belt.

**NOTE: Clean drive pulley for proper belt alignment.**

**NOTE: Seed belt flights should be oriented as shown.**

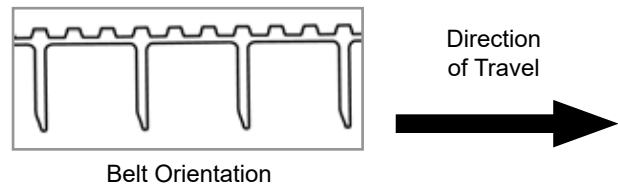

#### BRUSH WHEEL REPLACEMENT

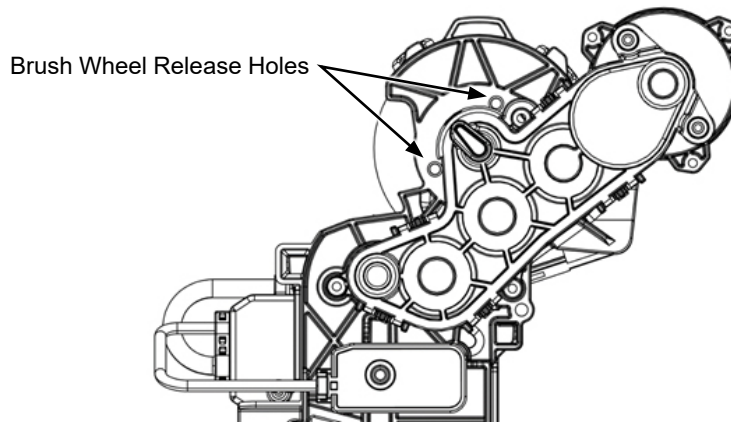

1. Remove retaining locknut on top of brush wheel.
2. Push brush wheel off of drive shaft by threading two seed sensor mounting screws into the brush wheel release holes. Thread screws in evenly on both sides to provide even pressure on brush wheel and prevent damage to shaft or wheel.
3. Replace new brush wheel and locknut.





**NOTE: Replace locknut after brush wheel replacement if it has been removed more than 5 times as locking feature may be compromised.**

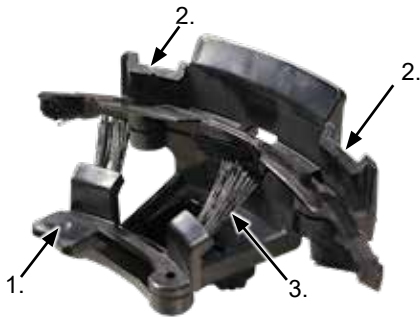
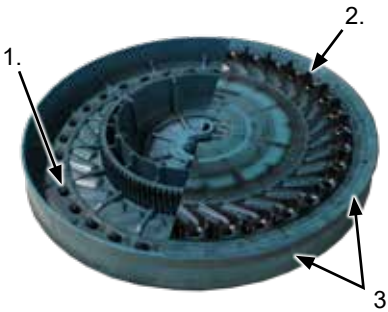

**NOTE: Poor seed spacing could be caused by missing scrubber block in delivery tube assembly.**

**NOTE: It is recommended to store delivery tube assemblies in a separate location during off-season to prevent damage from rodents.**

**NOTE: Be sure nothing is sitting/applying pressure to brush wheel.**

**TRUE SPEED MAINTENANCE CHART**

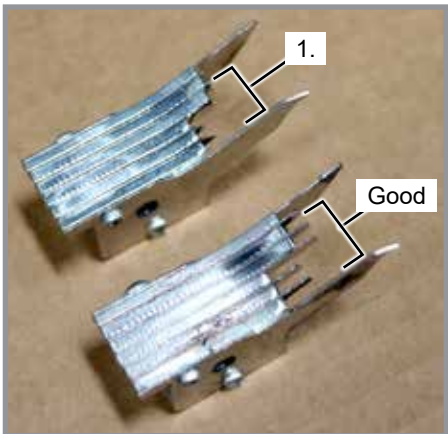
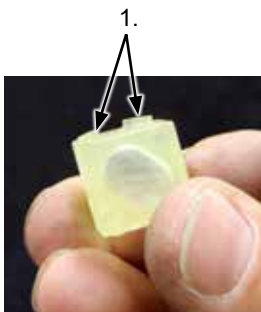
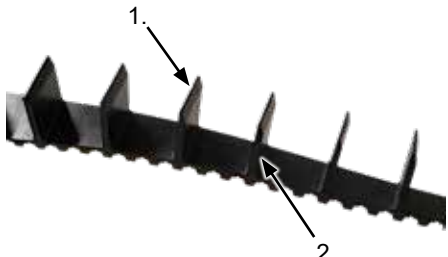
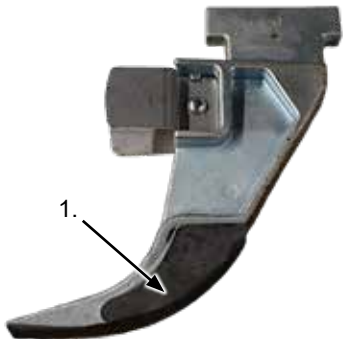
COMPONENT	INSPECT	REPLACE	WEAR CHARACTERISTICS	
Singulator	Annually	Every 500 row acres or as needed		<ol style="list-style-type: none"> <li>1. Reduced volume of wear indicator.</li> <li>2. Reduced depth in wear indicator.</li> <li>3. Reduced brush pack stiffness.</li> <li>4. Frayed bristles or having a permanent set.</li> </ol>
Seed disc	Annually	Every 1000 row acres or as needed		<ol style="list-style-type: none"> <li>1. Prominent wear on seed orifice edges.</li> <li>2. Deformed/damaged seed paddles.</li> <li>3. Pronounced ridges.</li> </ol>
Ejector wheel	Annually	Every 500 row acres or as needed		<ol style="list-style-type: none"> <li>1. Deformed/damaged ejector wheel punches.</li> <li>2. Worn ejector pins.</li> </ol>
Meter drive gear	Annually	Every 2000 row acres or as needed		<ol style="list-style-type: none"> <li>1. Deformed/damaged gear teeth.</li> <li>2. Loose shaft bearings.</li> </ol>
Brush wheel	Annually	Every 500 row acres or as needed		<ol style="list-style-type: none"> <li>1. Frayed, bent, or broken brush wheel bristles.</li> <li>2. Missing brush filament.</li> <li>3. Exposed filament retention wire.</li> </ol>
Delivery tube gearbox	Annually	As needed		<ol style="list-style-type: none"> <li>1. Loose bearings.</li> </ol>

COMPONENT	INSPECT	REPLACE	WEAR CHARACTERISTICS	
Comb	Annually	Every 500 row acres or as needed		<p>1. Reduced comb tip length.</p>
Scrubber block	Annually	Every 500 row acres or as needed		<p>1. Reduced volume on <u>both</u> sides of block. Replace when ribs are less than .025 tall.</p>
Seed belt	Annually	Every 1500 row acres or as needed		<p>1. Deformed/damaged flight tips. 2. Bent flights.</p>
Scraper	Every 200 row acres	Every 500 row acres or as needed		<p>1. Noticeable wear on both scraper pads. Replace when scraper pads are less than 1/16" thick or worn down to the level of the surrounding metal.</p>
Lower Seed Relief	Every 250 row acres	Every 500 row acres or as needed		<p>1. Wear on leading edge. 2. Replace when wear line is reached.</p>

## GAUGE WHEEL ADJUSTMENT

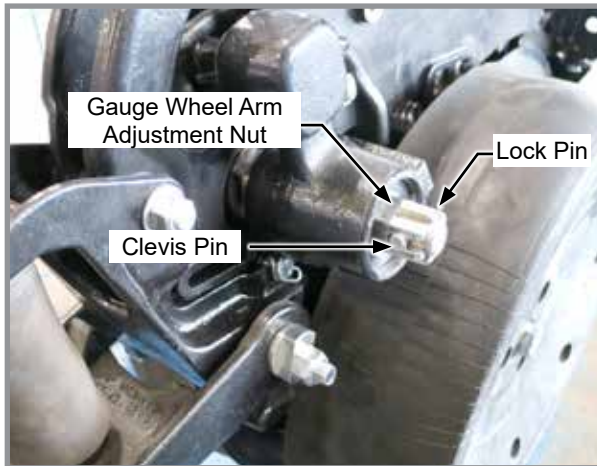

Align the closest adjustment nut slot and hole in spindle, secure with clevis pin and lock pin.

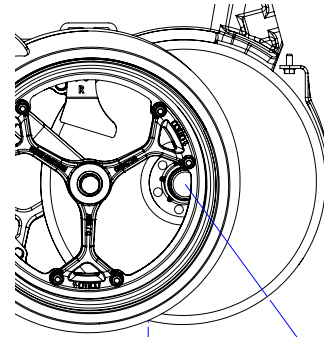

Adjust gauge wheel adjustment nut to lightly contact opener disc blade in this area for 4" to 6". Check adjustment in operating position.

### Gauge Wheel Adjustment

Remove lock pin and clevis pin from gauge wheel arm adjustment nut. Unscrew or screw in nut to adjust contact between gauge wheels and opener blades. Gauge wheels should lightly contact opener blades to prevent accumulation of dirt or trash. Gauge wheels and opener blades should turn with only slight resistance.

Use the following guidelines:

**NOTE: Set depth adjustment handle at 3x2 position and lift gauge wheel to stop one side at a time.**

Contact should be no less than one half of the rotation of the wheel, while not sticking in any position (it does not have to be continuous). Wheel should rotate in the direction of travel of the row unit. Wheel can be held in position by supporting the spindle bolt head.

## GAUGE WHEEL ARM PIVOT SPINDLE REPLACEMENT

**NOTE:** Spindle replacement should take place if threads are damaged and/or worn.

1. Remove lock pin and clevis pin from gauge wheel arm adjustment nut, that locks pivot spindle in place. Rotate nut counter-clockwise to unscrew from spindle.
2. Remove gauge wheel and arm assemblies from shank assembly.
3. Remove spindle using impact socket tool (P/N: G10974201).
4. Ensure spindle threads are clean and apply anti-seize on threads.
5. Install replacement spindle and position as shown. Torque spindle to 1000 ft-lbs.
6. Reinstall gauge wheel and arm assemblies. Adjust for proper gauge wheel tire/disc blade clearance.

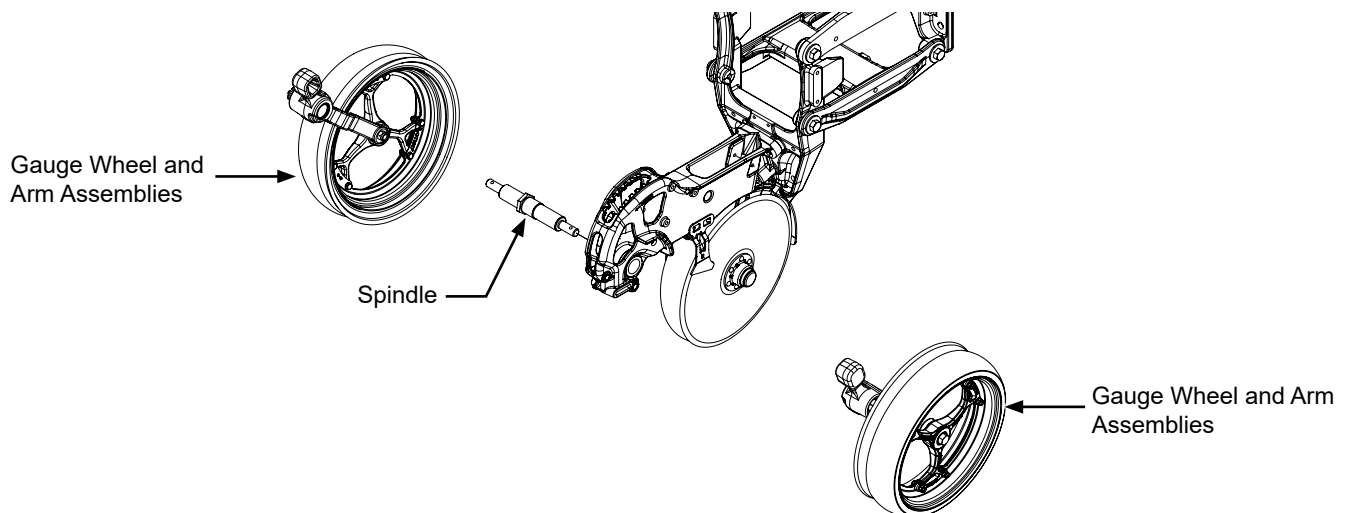



### GAUGE WHEEL ARM BUSHING/SEAL

NOTE: Replace when bushing/seal is worn or damaged.

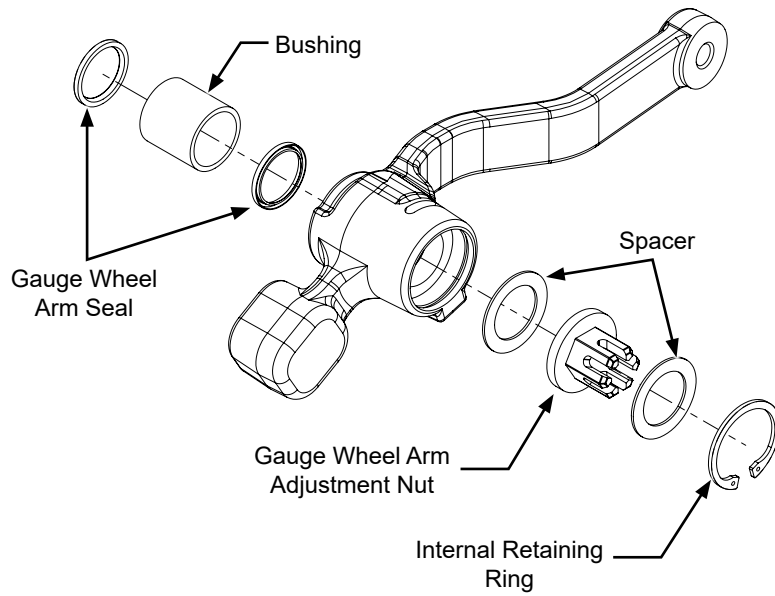
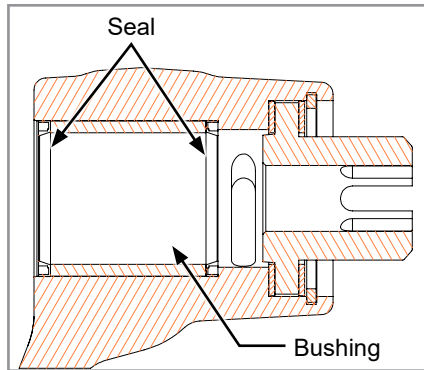

## 15" SEED OPENER DISC BLADE/BEARING ASSEMBLY

### NOTICE

Excessive blade contact may result in premature disc opener bearing/hub failures and excessive wear on seed tube guard/inner scraper. When properly adjusted, if one blade is held in fixed position, opposite blade should rotate with less than 5 pounds force (22 newtons) at outer edge of blade.

Maintain approximately  $1" \pm \frac{1}{2}"$  ( $3 \pm 5$  cm) of blade-to-blade contact to properly open and form seed trench. As blade diameter decreases due to wear, it is necessary to relocate machine bushings from inside to outside to maintain  $1" \pm \frac{1}{2}"$  ( $3 \pm 5$  cm) of contact.

**NOTE:** Proper blade clearance is critical. Blades should have  $1" \pm \frac{1}{2}"$  ( $3 \pm 5$  cm) contact in this area. Contact can be measured with two 0.005" feeler gauges, lightly lodge between the blades oriented per the dimension in the illustration. When blades are turned by hand in opposite directions against each other, there should be only light resistance to turning. Re-adjust blade scraper if necessary to center it between the blades.

**NOTE:** Replace blades if proper blade-to-blade contact cannot be maintained after relocating machine bushings or if blade diameter wears below  $14\frac{1}{2}"$  (36.8 cm). If there is an opening between the top of the blade and the shank, the blades are below  $14\frac{1}{2}"$ .

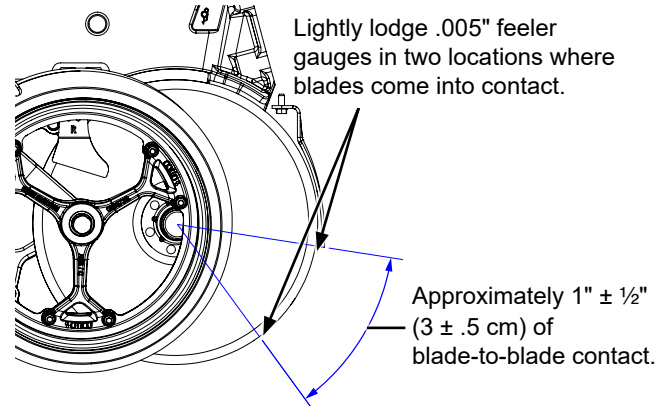

### REPLACE DISC BLADE/BEARING ASSEMBLY

**NOTE:** Only bearing may need to be replaced if there is excessive endplay or if bearing sounds or feels rough when disc blade is rotated.

1. Remove gauge wheel, scraper, and bearing dust cap.
2. Remove cap screw, washer and disc blade/bearing assembly. Machine bushings between shank and disc blade are used to maintain approximate  $1" \pm \frac{1}{2}"$  ( $3 \pm 5$  cm) of blade-to-blade contact.

### NOTICE

Left hand side of opener uses a left hand threaded cap screw. **DO NOT OVER TIGHTEN.** Damage to shank threads require replacement of row unit shank assembly.

3. Install machine bushing(s), new disc blade bearing assembly, washer and cap screw. Torque  $\frac{5}{8}"$ -11 Grade 5 cap screw to 125 ft-lb (169 N-m).

**NOTE:** Replace disc blades only with disc blades of equal thickness.

4. Install bearing dust cap, scraper, and gauge wheel.

## 15" SEED OPENER DISC BLADE/BEARING ASSEMBLY (CONTINUED)

### REPLACE BEARING ONLY

1. Remove gauge wheel, scraper, bearing cap, cap screw, washer and disc blade/bearing assembly.
2. Remove ¼" rivets from bearing housing to expose bearing.
3. Installing new bearing. Install three evenly spaced ¼" cap screws into three of six holes in bearing housing to hold bearing and bearing housing in place. Install rivets in other three holes. Remove ¼" cap screws and install rivets in those three holes.
4. Reinstall disc blade/bearing assembly, washer and cap screw. Torque ⅝"-11 cap screw to 110 ft-lb.
5. Install bearing dust cap, scraper, and gauge wheel.

## SEED TUBE GUARD/INNER SCRAPER

Seed tube guard protects seed tube and acts as inner scraper for seed opener disc blades.

Remove seed tube and check for wear. Excessive wear on seed tube indicates a worn seed tube guard. Replace seed tube guard if it measures ⅝" or less at lower end. A new seed tube guard measures approximately ⅞".

**NOTE: No till planting or planting in hard ground conditions, especially when planter is not equipped with no till coulters, and/or excessive blade-to-blade contact increases seed tube guard wear and requires more frequent inspection and/or replacement.**

Remove gauge wheel and disc blade from one side of row unit. Lift up inner scraper approximately 90° to remove from slot when replacement is necessary.



**Seed Tube Guard/Inner Scraper**  
(Gauge wheel/seed opener disc blade removed for easier identification of scraper)  
**True Rate Scraper Shown**

## ROW UNIT MOUNTED NO TILL COULTER

Check nuts and hardware periodically for proper torque.

**NOTE: Torque  $\frac{5}{8}$ " spindle hardware to 120 ft-lb (162 N-m).**

Be sure coulters are positioned square with row unit and aligned in front of row unit disc opener.

Coulter blade can be adjusted to one of four settings. Initially blade is set in highest position. As blade wears it can be adjusted to one of three lower settings. See "Row Unit Mounted No Till Coulter" in Row Unit Operation section of this manual.

Replace 16" diameter coulters when worn to 14½" (37 cm).



Row Unit Mounted No Till Coulter

## COULTER OR ROW UNIT MOUNTED RESIDUE WHEELS W/TREADER

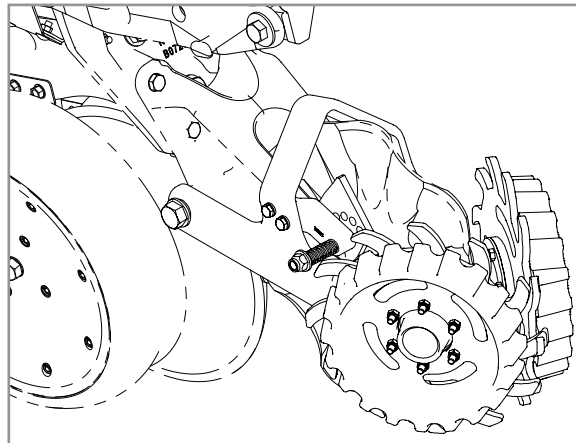

Coulter Mounted Residue Wheels W/Treader

Wheel hubs are equipped with sealed bearings. If a bearing sounds or feels rough when wheel is rotated, replace them.

## SPIKED CLOSING WHEEL

Inner parts of spiked closing wheel will begin to wear at approximately 70% of life. Flip/reverse wheel to utilize remaining life of wheel.

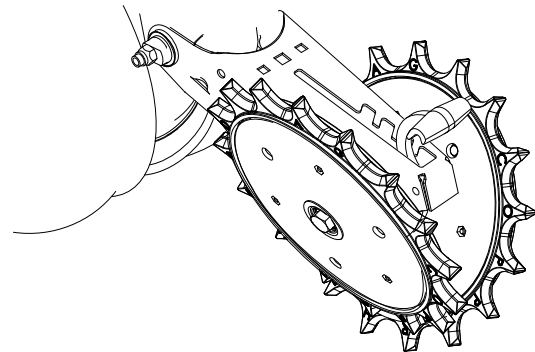

Row Unit Spiked Closing Wheel

## YETTER 2940 AIR ADJUST RESIDUE MANAGER MAINTENANCE

### **WARNING**

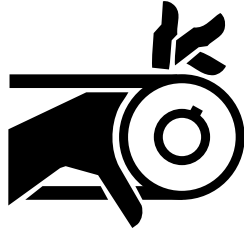

Serious injury may occur from moving parts such as belts, pulleys, flywheels, or fans if they come in contact with you or your clothing.

Do not operate air compressor without protective belt guards installed. Replace damaged protective covers or guards immediately.

### **WARNING**

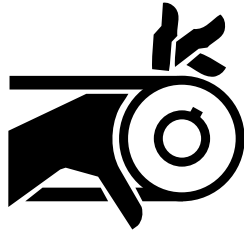

Hydraulic air compressor with automatic controls can restart at any time and cause bodily injury.

Always unplug air compressor and drain air tanks completely before attempting any repairs or performing maintenance. Never allow children or adolescents to operate air compressor.

### **WARNING**

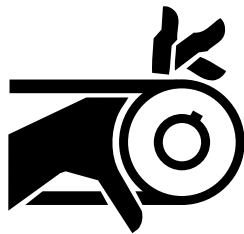

Serious injury may occur if repairs are attempted with damaged, missing, or removed protective guards, shrouds, or missing covers.

All repair to the air compressor should be made only by authorized or trained service personnel.

### **WARNING**



Serious burn injuries could occur from touching exposed metal parts such as compressor head, copper/ braided discharge lines, and hydraulic motor during operation and even after compressor is shut down for sometime.

Never touch any of the exposed metal parts during operation and for an extended period of time after air compressor has shut down. Do not attempt maintenance on the unit until it has been allowed to completely cool.

Compressor oil change

Compressor needs oil changed after initial 50 hour break in, then oil should be changed every 1000 hours. 17 ounces (½ liter) of oil is required to fill compressor.

**NOTE: 1 quart of hydraulic air compressor oil is P/N: G10649401.**

Reciprocating air compressor pumps will consume a certain amount of oil under normal operation. When filling crankcase with oil, use a single viscosity, non-detergent oil blend specifically for air compressor use (refer to chart). **DO NOT USE A DETERGENT OIL!!**

**TEMPERATURE**

Fahrenheit (Celsius)	0°-32°F (-17°-0°C)	32°-55°F (0°-13°C)	56°-100°F (14°-38°C)	-10°-115°F (-23°-47°C)
Non-Detergent Air Compressor Oil*	10 WT	20 WT	30 WT	Synthetic Oil

\*A suitable air compressor oil has additives to reduce wear, eliminate foaming, and prevent carboning.

**NOTE: All models are splash lubricated by means of dippers on connecting rods. The pump MUST be operated in a level position for proper lubrication, pump is located on planter toolbar for this purpose. The planter toolbar should be level so the compressor should always be level.**

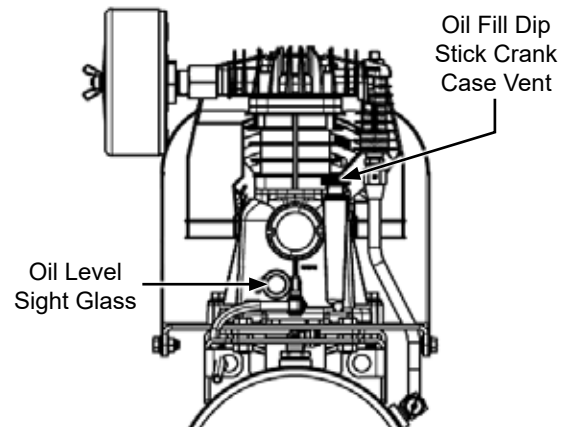
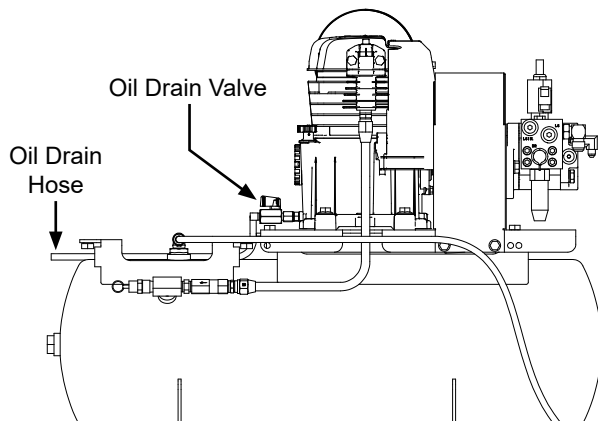

**NOTE: Compressor must be on level ground to avoid over or under filling oil.**

1. Place container (capable of holding approximately 1 quart) underneath oil drain hose.
2. Open oil drain valve on compressor to start flow of old oil. When oil stops coming out close drain valve.
3. Remove oil dipstick and slowly fill pump with oil until oil reaches fill line on sight glass.

**NOTE: Fill pump slowly as there is a delay between oil entering pump and seeing oil on the sight glass.**

4. Confirm oil level is full on the dipstick as well.
5. Reinstall dipstick.

Replacing Air Filter

Air filter needs to be replaced annually.

1. Remove wing nut on the air filter housing.
2. Remove air filter cover and air filter.
3. Reinstall new air filter. See parts manual for filter part number.
4. Reinstall filter cover and wing nut, making sure filter is sealed between filter base plate and cover.

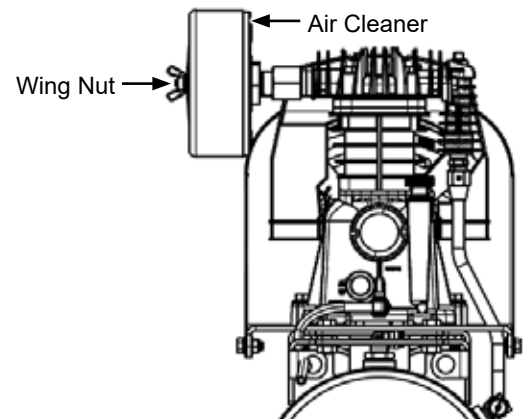
Compressor Water Drain

**NOTE: It is recommended to drain water out of the compressor after each day of use.**

**NOTE: Compressor needs to be level when draining tank.**

To drain water: Open drain cock at the bottom of compressor tank, let all water drain and then close drain cock.

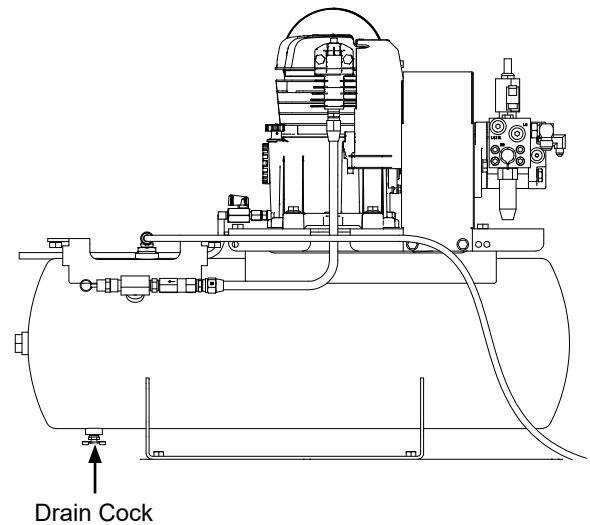
Re-Torque Compressor Head Bolts

Compressor head bolts should be re-torqued after a break in period of 200 hours or 4 weeks of operation. Re-torque head bolts to 19 ft-lbs.



Air Bag Replacement

Replace air bags as needed.

Remove existing airbag and hardware. Discard.

Install new airbag using  $\frac{5}{8}$ " hex nut and  $\frac{5}{16}$ "-18 x  $\frac{3}{4}$ " cap screw applying blue thread lock.

Torque hex nut to 115±15 lb-in; cap screw to 36±12 lb-in maximum.

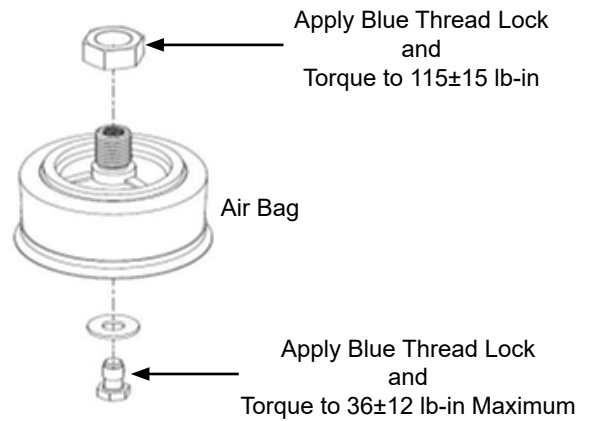

Pneumatic Tubing

**NOTICE**

Do not distort or crush tubing when cutting. Cut tubing square using tube cutters (Kinze part number GA13169). An angle cut can cause air leaks affecting performance.

Air connections are made using push to connect adapters. If an airline pops out of an adapter, push it all the way back in. If an airline needs to be removed from an adapter, the push to connect collet must be pushed in before the airline can be removed.



**NOTE:** Do not push tubing into adapters too far, doing so could block flow to the outlet. Visually check airline before pushing in, a mark on tubing can be made for reference.

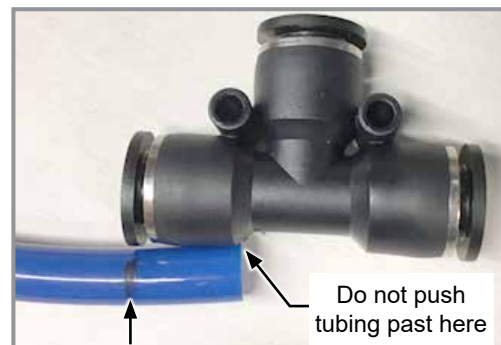



**TRACTOR MOUNTED PUMP DRIVE AND OIL COOLER****NOTICE**

Clean and grease PTO shaft coupling with high-pressure industrial coupling grease (Chevron® coupling grease or equivalent) meeting AGMA CG-1 and CG-2 Standards each time driveshaft is installed or premature wear and equipment failure can occur.

**NOTE: Periodically check and clean oil coolers.**

1. Replace 10-micron spin-on filters on tank annually.
2. Fill system with SAE 10W-20 multigrade wide temperature range transmission hydraulic fluid. Reservoir capacity is approximately 20 gallons (75.7 L).
3. Start system and run with tractor at idle and fans turned off for 1-2 minutes. Switch fans to full speed and run with tractor at idle for 1-2 minutes.
4. Check reservoir fluid level and fill as required. Hydraulic fluid level should be within 1"- 2" from top of reservoir after pump has run and hydraulic hoses have been primed to allow fluid to expand when heated.

## CHECK VALVE

A check valve is located in each vacuum fan motor block assembly and operates as a return line check to prevent vacuum fan motor reverse operation. Remove and inspect valve. If it does not operate properly. Check for foreign material and if O-ring is leaking internally. Replace if defective.

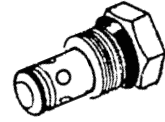

## FLOW CONTROL VALVES

Two flow control valves are located in valve block on both wings of planter. Flow control valves should be adjusted for row marker raise and lower speed as part of assembly procedure or upon initial operation. If valve fails to function properly or requires frequent adjustment, it should be removed for inspection. Check for foreign material and contamination on valve and seating areas of valve body. Replace defective components.

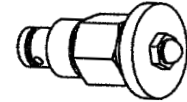

## PRESSURE RELIEF VALVES

Pressure relief valve in valve block on left wing of planter functions during lowering out of raised transport sequence. Valve is factory set and should require no additional adjustment. Pressure relief valve located in valve block on tongue functions during tongue extend cycle. This pressure relief valve ensures latch cylinder extends and releases prior to tongue extending. Valve is factory set and should require no additional adjustment. Contact your Kinze Dealer for service.

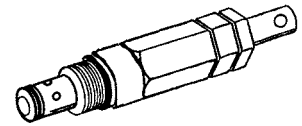
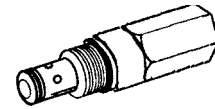

### NOTICE

Connect hydraulic motor case drain to a case drain return line with zero pressure on tractor or hydraulic motor will be damaged. DO NOT connect hydraulic motor case drain to SCV outlet. Contact tractor manufacturer for specific details on "zero pressure return".

## PRESSURE COMPENSATED FLOW CONTROL VALVES

There are three pressure compensated flow control valves used on the planter. One is located on the vacuum fan block, on the ASD fan block and on the power pack block.

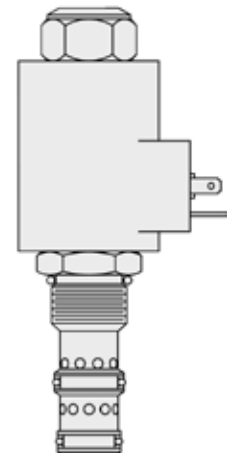

## SOLENOID VALVE

Solenoid valve consists of a chambered body with an electric coil actuated cartridge valve.

If solenoid or solenoids fail to operate, first determine if problem is electrical or hydraulic. If valve is working properly, a click will be heard when solenoid coil is energized and valve stem opens. If no sound is heard, check solenoid coil by touching top of coil housing with a metallic object such as a pliers or screwdriver. If coil is working properly, coil housing will be strongly magnetized when energized. If voltage to coil is low it will be weakly magnetized when energized and no click will be heard.

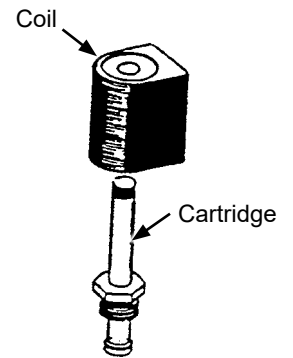

## PNEUMATIC DOWN PRESSURE AIR COMPRESSOR TANK

Moisture should be drained daily from the tank. Tank should be drained completely for storage.

To drain tank, locate drain plug on the bottom of tank. Stand off to the side of tank and pull cable attached to drain.

**NOTE: If moisture is not drained from tank rust particles will form inside tank.**

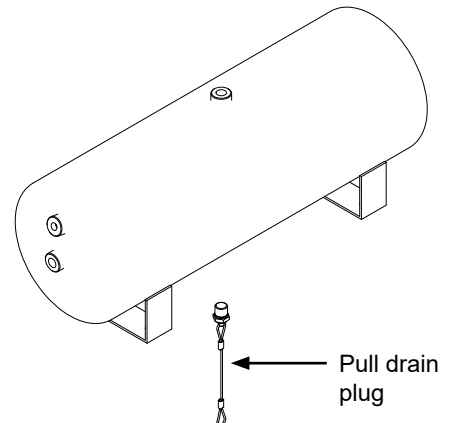

## ROW MARKER BREAK AWAY

When replacing marker shear bolts, the jam bolt must be re-adjusted. The jam bolt acts as a stop and puts a slight pre-load on the shear bolt.

1. Remove broken shear bolt.
2. Install new shear bolt with spare provided on the marker.
3. Reverse or spin jam bolt out to remove slack in the joint. This tightens the marker breakaway.
4. Once initial slack has been removed, turn the jam bolt 1 additional flat (60°) to pre-load the shear bolt.
5. Hold the jam bolt head in place and tighten hex jam nut to secure jam bolt.

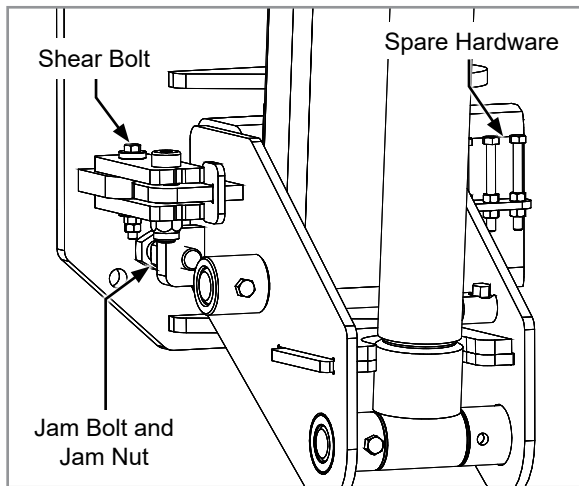

40' Toolbar

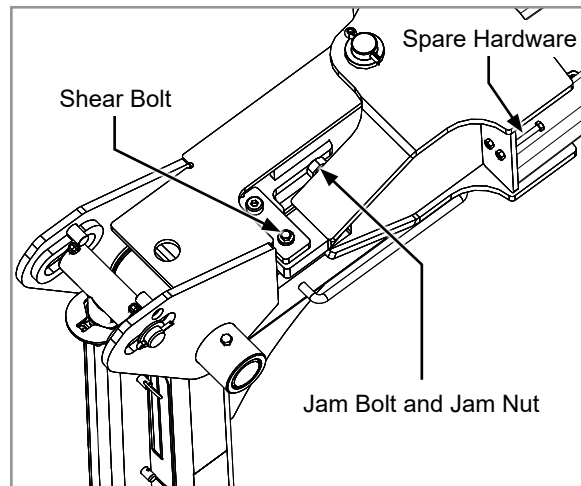

60' Toolbar

## ROW MARKER BEARING LUBRICATION OR REPLACEMENT

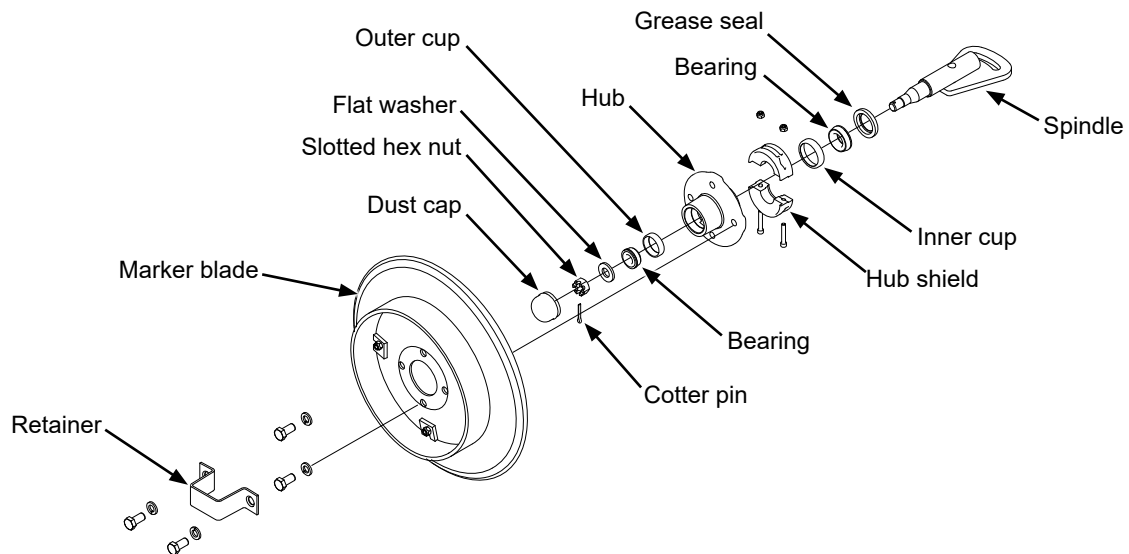

1. Remove retainer and marker blade.
2. Remove dust cap from hub.
2. Remove hub shield. Note direction of installation.
3. Remove cotter pin, slotted hex nut, and washer.
4. Slide hub from spindle.
5. Remove bearings and cups and discard if bearings are being replaced. Clean hub and dry. Remove bearings only and not cups if repacking.
6. Press in new bearing cups with thickest edge facing in. (Bearing replacement procedure only.)
7. Pack bearings with heavy duty wheel bearing grease thoroughly forcing grease between roller cone and bearing cage. Fill the space between the bearing cups in the hub with grease.
8. Install rubber seal into grease seal. Place inner bearing in place and press in new rubber seal/grease seal.
9. Clean spindle and install hub.
10. Install outer bearing, washer and slotted hex nut. Tighten slotted hex nut while rotating hub until there is some drag. This ensures all bearing surfaces are in contact. Back off slotted nut to nearest locking slot and install cotter pin.
11. Fill dust caps approximately  $\frac{3}{4}$  full of wheel bearing grease and install on hub.
12. Install hub shield.
13. Install marker blade and retainer on hub. Tighten hardware evenly.

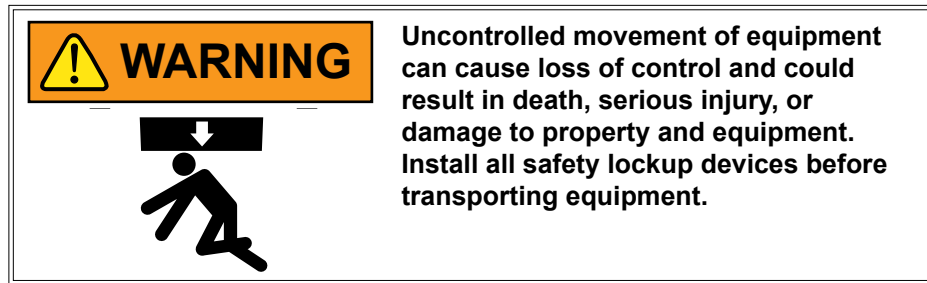

## TRANSPORT AND LIFT/GROUND DRIVE WHEEL BEARING REPACK OR REPLACEMENT

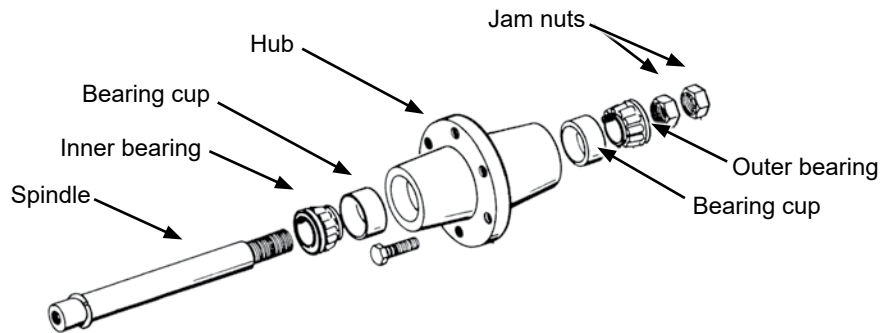

1. Raise tire clear of ground and remove wheel.
2. Remove double jam nuts and slide hub from spindle.
3. Remove bearings and cups and discard if bearings are being replaced. Clean hub and dry. Remove bearings only and not cups if repacking.
4. Press in new bearing cups with thickest edge facing in. (Bearing replacement procedure only.)
5. Pack bearings with heavy duty wheel bearing grease thoroughly forcing grease between roller cone and bearing cage. Fill space between bearing cups and hub with grease.
6. Place inner bearing in place.
7. Clean spindle and install hub.
8. Install outer bearing and jam nut. Tighten jam nut while rotating hub until there is some drag. This ensures all bearing surfaces are in contact. Back off jam nut  $\frac{1}{4}$  turn or until there is only slight drag when rotating hub. Install second jam nut to lock against first.
9. Install wheel on hub. Tighten hardware evenly. Refer to the torque chart information included previously in this section.

## BATTERY CARE

### NOTICE

Read and follow all manufacturers labels and instructions.

#### Battery Specifications

Chemistry:	Wet lead acid (Low maintenance)
Voltage:	12.00
Milliamp Hours:	0 mAH
Capacity:	17.00 AH
Weight:	15.30 lb
Length:	7.72"
Width:	5.19"
Height:	7.30"
Termination:	Top post (auto type)

#### BEFORE PLANTING SEASON

- Check and clean all connections.
- Fully charge batteries before installing into the planter.
- Batteries more than two years old should be load checked.
- Reinstall batteries or connect the negative ground cables.

#### PREPARATION FOR STORAGE

Planter batteries that are stored for more than one month should be cared for as follows:

- Remove the batteries or disconnect the negative ground cables.
- Fully charge batteries before storing.
- Store in a cool dry location.
- Keep from freezing.

## PREPARATION FOR STORAGE

- Store planter in a dry sheltered area if possible.
- Remove all trash from row units and frame. Remove dirt that can draw and hold moisture.
- Lubricate planter and row units at all lubrication points.
- Inspect planter for parts that are in need of replacement and order during “off” season.
- Make sure all seed and granular chemical hoppers are empty and clean.
- Remove vacuum hose from each seed meter. Operate vacuum fan at full hydraulic flow from tractor for two minutes to clear manifolds, hoses and fittings of dust and debris.
- Clean breather on analog vacuum and pressure gauges.
- Grease or paint disc openers/blades and row marker disc blades to prevent rust.
- Flush liquid fertilizer tanks, hoses and metering pump with clean water. See [“Pump Clean Out and Storage” on page 4-24](#) if applicable.
- See [“Battery Care” on page 5-37](#) if planters are equipped with batteries.
- Seed Meters and Seed Delivery Tubes:

**NOTE: It is recommended to store delivery tube assemblies in a separate location during off-season to prevent damage from rodents.**

1. Remove all seed from meter. Blow seed meter clean with air.
2. Remove seed disc and wash with soap and water and dry thoroughly if seed treatment buildup is present.
3. Remove seal, clean with compressed air, and reinstall vacuum seal if debris buildup is observed.
4. Inspect all parts and replace worn parts.
5. Reassemble meter except for seed disc. Store meter and seed tube in a safe dry location.

**NOTE: Remove seed discs from meters for annual storage and store them in a safe dry rodent free location.**

- Bulk Fill System:

1. Clean out bulk fill hopper, entrainment assembly, and delivery hoses.
2. Disconnect delivery hoses from entrainer ports. Install small orange caps onto ports. Attach hoses to caps.
3. Disconnect delivery hoses from air dissipator at each row unit. Install large orange caps. Attach hoses to caps.
4. Check all bolts and fasteners used to assemble and attach entrainment device are tight.
5. Loosen latches on entrainer cleanout doors to remove pressure from door gasket.
6. Inspect all seed delivery hoses and replace any that are worn, cut, or cracked.

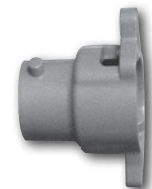

**Entrainer Cap**



**Row Unit Cap**



FERTILIZER IPN HARNESS (P/N: 10765601)

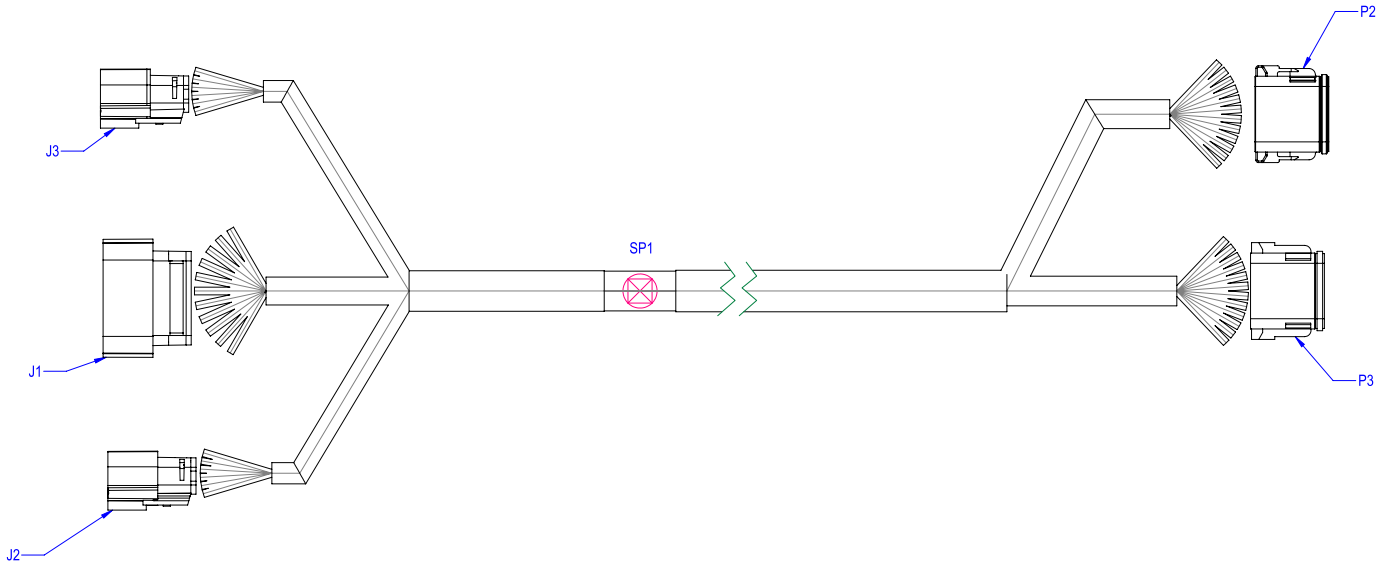

WIRE HOOKUP CHART							
REF DES	FROM	USED W/	TO	USED W/	GAUGE	COLOR	FUNCTION
W1	J1:17	6	P3:2	8	16	BLK	FERT LOW LEVEL SENSOR (GND)
W2	SP1:OUT	—	P2:11	8	16	RED	FERT LOW LEVEL SENSOR (PWR)
W3	SP1:OUT	—	P3:5	8	16	RED	FERT FLOW METER (PWR)
W4	J1:3	6	P3:12	8	16	RED	FERT PRESS REGULATOR (+)
W5	J1:4	6	P3:11	8	16	BLK	FERT PRESS REGULATOR (-)
W6	J1:13	6	P3:10	8	16	WHT	FERT RAIL PRESSURE SENSOR INPUT (ANALOG)
W7	J1:19	6	P3:9	8	16	BLK	FERT RAIL PRESS SENSOR (GND)
W8	J1:20	6	P3:8	8	16	RED	FERT RAIL PRESS SENSOR (PWR)
W9	J1:15	6	P3:7	8	16	YEL	FERT FLOW METER (FREQ)
W10	J1:16	6	P3:6	8	16	ORN	FERT LOW LEVEL SENSOR (DIGITAL)
W11	J2:5	6	P3:4	8	16	RED	FERT PUMP INLET SUCTION SENSOR (PWR)
W12	J1:18	6	SP1:IN	—	16	RED	FERT TANK LOW LEVEL (PWR) FLOW METER (12V) (PWR)
W13	J2:4	6	P3:3	8	16	BLK	FERT PUMP INLET SUCTION SENSOR (GND)
W14	J2:8	6	P3:1	8	16	YEL	FERT PUMP INLET SUCTION SENSOR (ANALOG)
W15	J2:1	6	P2:8	8	16	VLT	FERT SYSTEM SHUTOFF VALVE (+)
W16	J2:2	6	P2:7	8	16	BLK	FERT SYSTEM SHUTOFF VALVE (-)
W17	J3:1	6	P2:6	8	16	RED	FERTILIZER PUMP (+)
W18	J3:2	6	P2:5	8	16	BLK	FERTILIZER PUMP (-)
W19	J3:5	6	P2:4	8	16	RED	FERT PUMP RPM SENSOR (PWR)/FERT PUMP INLET FLUID SWITCH (PWR)
W20	J3:6	6	P2:3	8	16	BLK	FERT PUMP RPM SENSOR/ FERT PUMP INLET FLUID SWITCH/ FERT FLOW METER (GND)
W21	J3:7	6	P2:2	8	16	BLU	FERTILIZER PUMP INLET FLUID SWITCH (DIGITAL)
W22	J3:8	6	P2:1	8	16	YEL	FERTILIZER PUMP RPM SENSOR INPUT (FREQ)
W23	J1:7	6	P2:10	8	18	ORN	FERTILIZER FLOW METER TRANSITION VALVE + PWM
W24	J1:8	6	P2:9	8	18	GRY	FERTILIZER FLOW METER TRANSITION VALVE - PWM
W25	J2:7	6	P2:12	8	18	BRN	FERTILIZER LOWER FLOW METER (FREQ) (SIG) (1k ohm PU to 12V)

LABEL TABLE			
CONNECTOR	CONNECTOR LABEL	CONNECTOR	CONNECTOR LABEL
J1	TO IPN J7	P2	TO FERT MODULE J2
J2	TO IPN J5	P3	TO FERT MODULE J3
J3	TO IPN J4	HARNESS LABEL	PART NUMBER REV / DATE VENDOR I.D.

**ETHERNET CABLES**

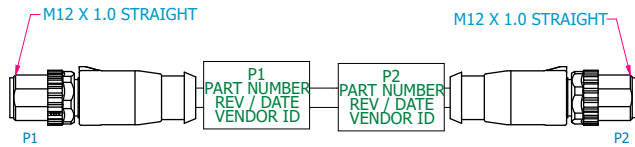
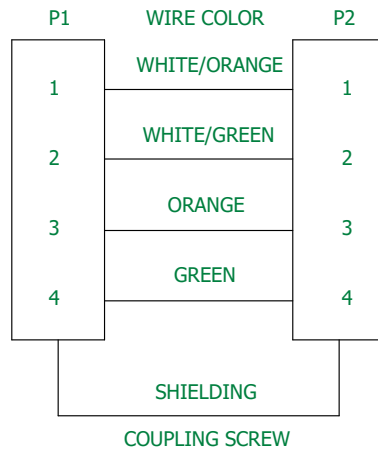

Part Number	Description
A22554-	Ethernet Ca CAT 5E (M12 STR-M12 STR)

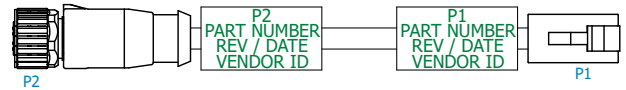

Part Number	Description
A25399-	Ethernet Ca CAT 5E (RJ45-Female M12 STR)

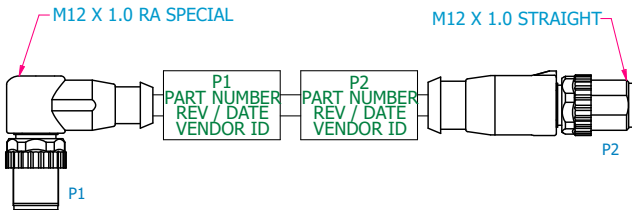

Part Number	Description
A22555-	Ethernet Ca CAT 5E (M12 RA-M12 STR)

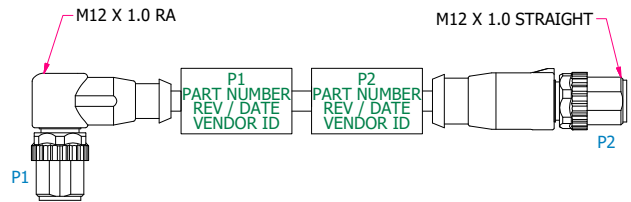

Part Number	Description
A24488-	Ethernet Ca CAT 5 (M12 RA-M12 STR)

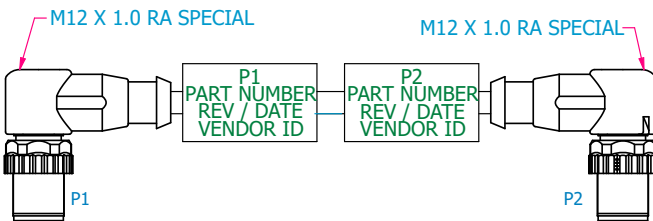

Part Number	Description
A22556-	Ethernet Ca CAT 5E (M12 RA-M12 RA)

**PTO REVERSER HARNESS (P/N: 10263101)**

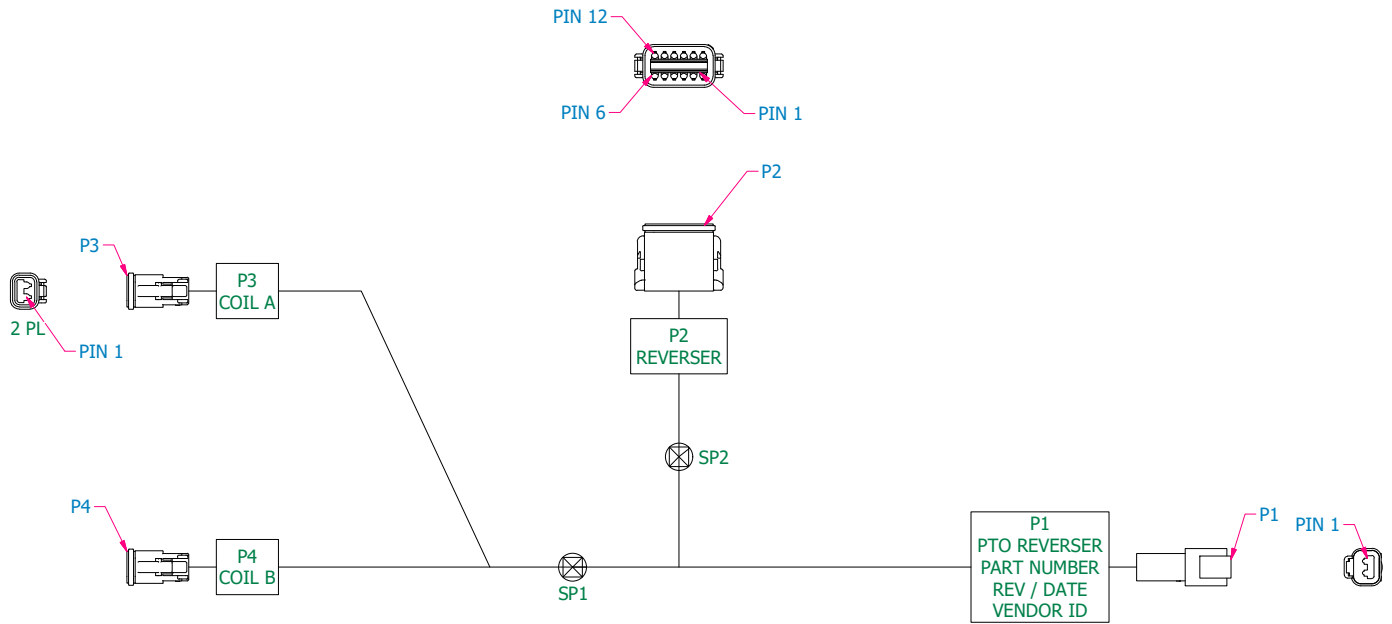

WIRE HOOKUP CHART							
REF DES	FROM	USED WITH ITEM	TO	USED WITH ITEM	GAUGE	COLOR	FUNCTION
W1	P1-1	5	SP2	—	16	RED	12V +
W2	P1-2	5	SP1	—	16	BLK	GND
W3	SP1	—	P2-7	4	16	BLK	GND
W4	SP1	—	P3-2	4	16	BLK	GND
W5	SP1	—	P4-2	4	16	BLK	GND
W6	SP2	—	P2-8	4	16	RED	12V+
W7	SP2	—	P2-9	4	16	RED	12V+
W8	P2-10	4	P2-11	4	18	RED	5V SIGNAL
W9	P2-6	4	P3-1	4	18	BLU	COIL A OUT (FWD)
W10	P2-4	4	P4-1	4	18	BRN	COIL B OUT (REV)

PTO HARNESS (P/N: 10200301)

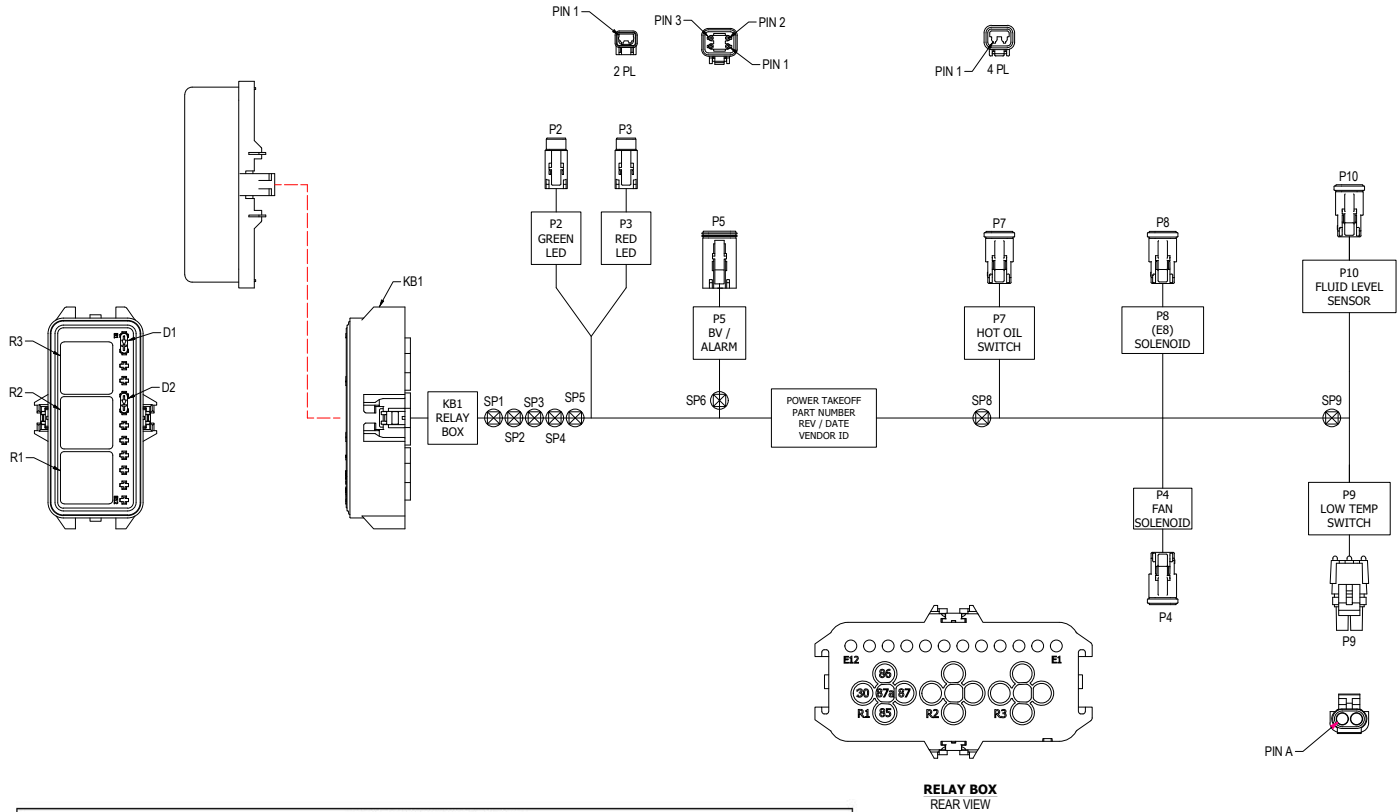

WIRE HOOKUP CHART							
REF DES	FROM	USED WITH ITEM	TO	USED WITH ITEM	GAUGE	COLOR	FUNCTION
W1	P5-4	16	SP1	—	16	RED	12V PWR
W2	SP1	—	P1-R1-30	25	14	RED	FAN RELAY (12V PWR)
W3	SP1	—	P1-R2-30	25	14	RED	FLUID LVL RELAY (12V PWR)
W4	SP1	—	P2-1	15	18	RED	GREEN LED (12V PWR)
W5	SP1	—	SP8	—	18	RED	12V PWR
W6	SP8	—	P7-1	16	18	RED	HOT OIL SWITCH (12V PWR)
W7	SP8	—	SP9	—	18	RED	12V PWR
W8	SP9	—	P9-A	19	18	RED	LOW TEMP SWITCH (12V PWR)
W9	SP9	—	P10-1	16	18	RED	FLUID LVL SWITCH (12V PWR)
W10	P4-2	—	SP6	16	18	BLK	FAN (GND)
W11	SP6	—	P5-1	16	18	BLK	BV (GND)
W12	SP6	—	P8-2	16	18	BLK	SOLENOID (GND)
W13	SP6	—	SP2	—	16	BLK	GND
W14	SP2	—	KB1-R1-86	25	14	BLK	FAN RELAY (COIL GND)
W15	SP2	—	KB1-R2-86	25	14	BLK	FLUID LVL RELAY (COIL GND)
W16	SP2	—	KB1-R3-86	25	14	BLK	HOT OIL RELAY (COIL GND)
W17	SP2	—	P2-2	15	18	BLK	GREEN LED (GND)
W18	SP2	—	P3-2	15	18	BLK	RED LED (GND)
W19	KB1-R1-85	25	P9-B	19	14	GRN	LOW TEMP SIGNAL (FAN COIL PWR)
W20	KB1-R1-87	25	P4-1	17	14	RED	FAN PWR (FROM RELAY)
W21	KB1-R2-85	25	P10-2	16	14	GRY	FLUID LVL SIGNAL (FLUID LVL COIL PWR)
W22	KB1-R2-87	25	KB1-R3-30	25	14	ORG	HOT OIL RELAY (PWR)
W23	KB1-R2-87a	25	SP3	—	14	BLU	FLUID LVL RELAY (NC OUT)
W24	SP3	—	KB1-E5	13	18	BLU	FLUID LVL RELAY (NC OUT RED LED)
W25	SP3	—	P5-2	16	18	BLU	FLUID LVL RELAY (NC OUT BV SIGNAL)
W26	KB1-R3-85	25	P7-2	16	14	WHT	HOT OIL SIGNAL (HOT OIL COIL PWR)
W27	KB1-R3-87	25	P8-1	16	14	VIO	ON/OFF POWER (NO OUT HOT OIL)
W28	KB1-R3-87a	25	SP4	—	14	YEL	HOT OIL SIGNAL
W29	SP4	—	P5-C	16	18	YEL	HOT OIL RELAY (NC OUT BV SIGNAL)
W30	SP4	—	KB1-E1	13	18	YEL	HOT OIL SIGNAL (NO DIODE)
W31	KB1-E2	13	SP5	—	18	BRN	RED LED POWER
W32	KB1-E6	13	SP5	—	18	BRN	RED LED POWER
W33	SP5	—	P3-1	15	18	BRN	RED LED POWER

**TRACTOR POWER HARNESS - 12 ROW, 16 ROW, AND 24 ROW (P/N: 10211901)**

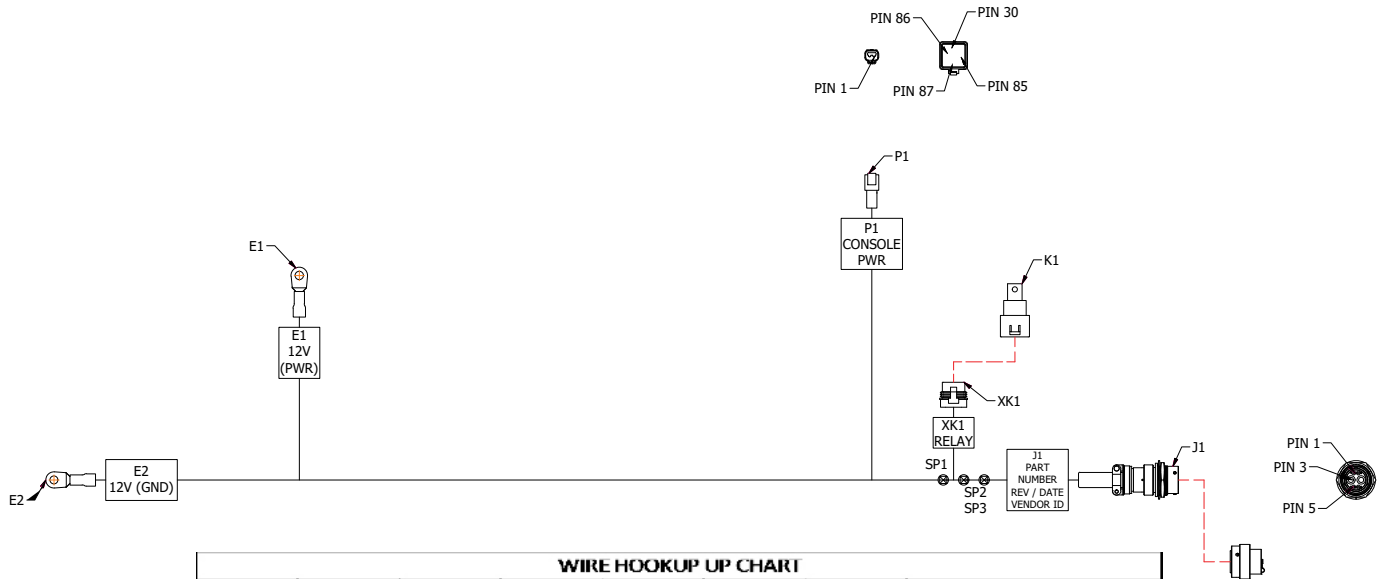

WIRE HOOKUP CHART							
REF DES	FROM	USED WITH ITEM	TO	USED WITH ITEM	GAUGE	COLOR	FUNCTION
W1	F1	---	SP1	---	2	RED	12V (PWR)
W2	SP1	---	XK1-30	13	10	RED	12V (PWR)
W3	XK1-87	13	SP2	---	10	RED	12V (PWR)
W4	SP2	---	J1-3	9	6	RED	12V (PWR)
W5	F2	---	SP3	---	2	BLK	12V (GND)
W6	SP3	---	J1-4	9	6	BLK	12V (GND)
W7	XK1-86	14	P1-1	11	18	BLU	SWITCH PWR (CONSOLE)
W8	XK1-85	14	P1-2	11	18	BLU	SWITCH GND (CONSOLE)

**TRACTOR POWER 10' EXTENSION HARNESS - 12 ROW, 16 ROW, AND 24 ROW**



P/N: 10060901/10060902

WIRE HOOKUP CHART							
REF DES	FROM	USED W/ ITEM	TO	USED W/ ITEM	GAUGE	COLOR	FUNCTION
W1	P1-3	3	SP1	---	6	RED	12V PWR
W2	SP1	---	SP3	---	4	RED	12V PWR
W3	SP3	---	P2-3	3	6	RED	12V PWR
W4	P1-4	3	SP2	---	6	BLK	12V GND
W5	SP2	---	SP4	---	4	BLK	12V GND
W6	SP4	---	P2-4	3	6	BLK	12V GND

FERTILIZER MODULE HARNESS (P/N:10741001)

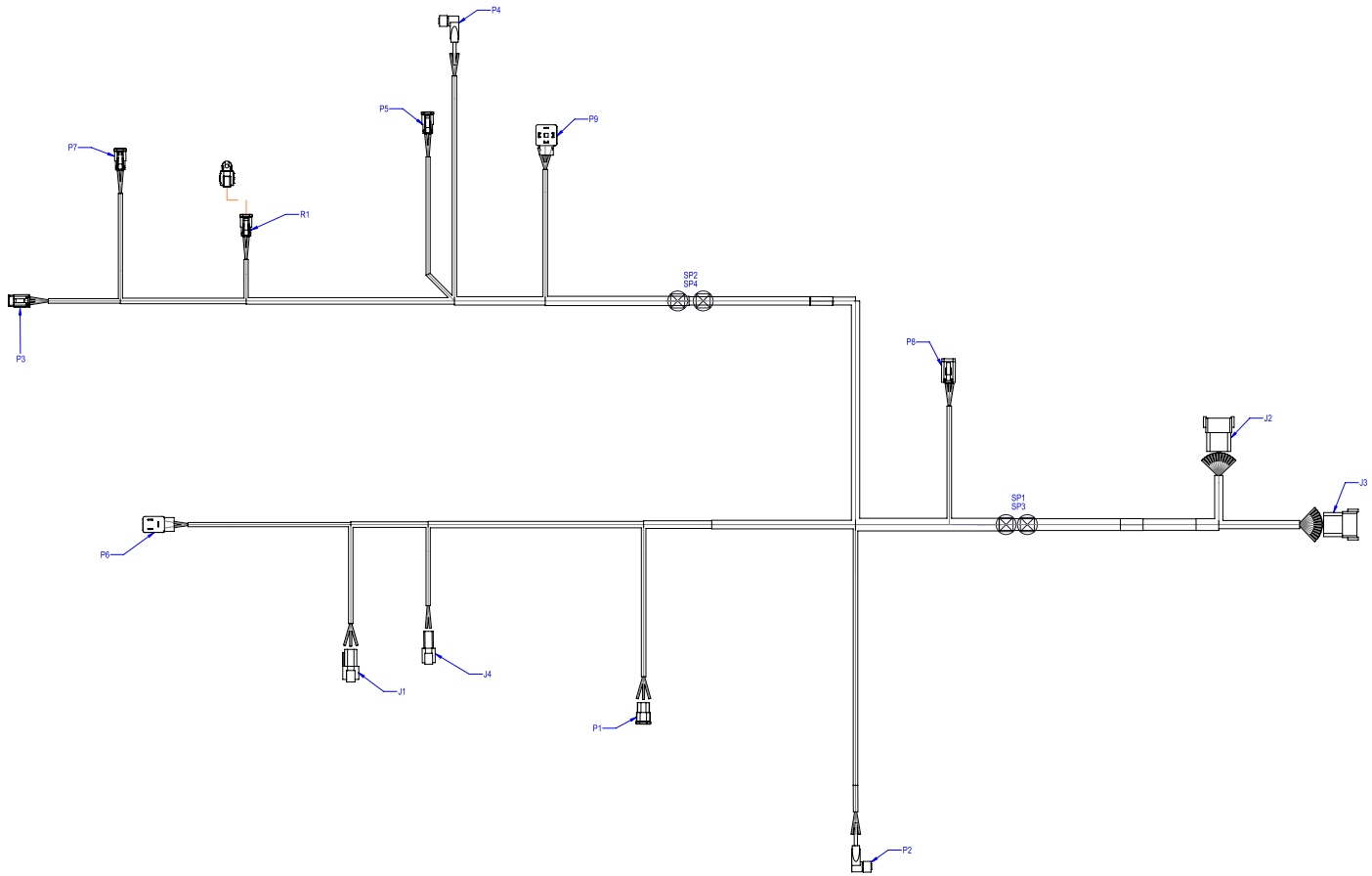

WIRE HOOK UP CHART							
REF DES	FROM	USED W/	TO	USED W/	GAUGE	COLOR	FUNCTION
W1	J3:12	10	P6:1	---	18	RED	FERT PRESS SENSOR REG (+)
W2	J3:11	10	P6:2	---	18	BLK	FERT PRESS SENSOR REG (-)
W3	J3:10	10	P8:4	14	18	WHT	FERT RAIL PRESS SENSOR (SIG)
W4	J3:9	10	P8:1	14	18	BLK	FERT RAIL PRESS SENSOR (GND)
W5	J3:8	10	P8:2	14	18	RED	FERT RAILPRESS SENSOR (PWR)
W6	J1:2	10	J3:7	10	18	YEL	FERT FLOW METER (FREQ)
W7	J3:6	10	P2:4	---	18	ORN	LOW LEVEL SENSOR (SIG)
W8	J1:1	10	J3:5	10	18	RED	FERT FLOWMETER (PWR)
W9	J3:4	10	SP3:IN	---	18	RED	FERT LOWER FOW METER / INLET SUCTION SENSOR (12V)(PWR)
W10	J3:3	10	P9:2	---	18	BLK	FERT PUMP INLET SUCTION SENSOR (GND)
W11	J3:2	10	P2:3	---	18	BLK	LOW LEVEL SENSOR (GND)
W12	J3:1	10	P9:3	---	18	BLU	FERT PUMP INLET SUCTION SENSOR (SIG)
W13	J2:12	10	P1:2	14	18	GRN	FERT LOWER FLOW METER (FREQ)(SIG)(1k ohm PU to 12V)
W14	J2:11	10	P2:1	---	18	RED	LOW LEVEL SENSOR (PWR)
W15	J2:10	10	J4:2	10	18	ORN	FERT FLOW METER TRANSITION VALVE + PWM
W16	J2:9	10	J4:1	10	18	GRY	FERT FLOW METER TRANSITION VALVE - PWM
W17	J2:8	10	P5:1	14	18	VLT	FERT SYSTEM SHUT OFF (+)
W18	J2:7	10	P5:2	14	18	BLK	FERT SYSTEM SHUT OFF (-)
W19	J2:6	10	P7:1	14	18	RED	FERT HYD MOTOR SOLE (PWR)
W20	J2:5	10	P7:2	14	18	BLK	FERT HYD MOTOR SOLE (GND)
W21	J2:4	10	SP2:IN	---	18	RED	FERT PUMP RPM SENSOR (PWR) / INLET FLUID SWITCH (PWR)
W22	J2:3	10	SP1:IN	---	18	BLK	FERT PUMP RPM SENSOR (GND) / INLET FLUID SWITCH (GND)
W23	J2:2	10	P4:4	---	18	BLU	FERT INLET SWITCH (SIG)
W24	J2:1	10	SP4:IN	---	18	YEL	FERT MOTOR RPM (SIG)
W25	SP1:OUT	---	J1:3	10	18	BLK	FERT FLOW METER (GND)
W26	SP1:OUT	---	P3:1	14	18	BLK	FERT PUMP RPM SENSOR (GND)
W27	SP1:OUT	---	P1:3	14	18	BLK	FERT LOWER FLOW METER (GND)
W28	SP1:OUT	---	P4:3	---	18	BLK	INLET FLUID SWITCH (GND)
W29	SP3:OUT	---	P1:1	14	18	RED	FERT LOWER FLOW METER (12V)(PWR)
W30	SP3:OUT	---	P9:1	---	18	RED	FERT PUMP INLET SUCTION SENSOR (PWR)
W31	SP2:OUT	---	P3:3	14	18	RED	FERT INLET SWITCH (PWR)
W32	SP2:OUT	---	P4:1	---	18	RED	FERT PUMP RPM SENSOR (PWR)
W33	SP2:OUT	---	R1:1	14	18	RED	PULL-UP RESISTOR (12V) (PWR)
W34	SP4:OUT	---	R1:2	14	18	YEL	PULL-UP RESISTOR (SIG)
W35	SP4:OUT	---	P3:2	14	18	YEL	FERT MOTOR RPM (SIG)

LABEL TABLE			
CONNECTOR	CONNECTOR LABEL	CONNECTOR	CONNECTOR LABEL
P1	FLOW METER LOW	P8	RAIL PRESS SENSOR
P2	LOW LEVEL TANK	P9	PUMP SUCTION SENSOR
P3	RPM SENSOR	R1	PULL UP RPM SENSOR
P4	INLET SWITCH	J1	FLOW METER HIGH
P5	FERT SHUT OFF	J2	TO FERT IPN HARNESS
P6	PRESS REGULATOR	J3	TO FERT IPN HARNESS
P7	FERT HYD MOTOR	J4	FLOW METER TRANSITION VALVE
HARNESS LABEL	PART # REV/ DATE VENDOR I.D.		

**FERTILIZER ROW UNIT EXTENSION HARNESS (P/N:10840301/10840302/10840303/10840304)**



WIRE HOOKUP CHART								LABEL TABLE			
REF DES	FROM	USED W/	TO	USED W/	GAUGE	COLOR	FUNCTION	J1	TO ROW UNIT	P2	FERT CUTOFF VALVE
W1	J1:5	7	P2:A	3	18	RED	FERT ROW CUTOFF VALVE (PWR)	J1	TO ROW UNIT	P2	FERT CUTOFF VALVE
W2	J1:6	7	P2:B	3	18	BLK	FERT ROW CUTOFF VALVE (GND)				
W3	J1:1	7	P1:1	---	18	BRN	FERT FLOW SENSOR (PWR)	P1	FERT FLOW SENSOR	HARNESS LABEL	PART NUMBER REV/DATE VENDOR I.D.
W4	J1:2	7	P1:3	---	18	BLU	FERT FLOW SENSOR (GND)				
W5	J1:3	7	P1:4	---	18	BLK	FERT FLOW SENSOR (SIGNAL)				

**PTO SYSTEM 12V POWER HARNESS (P/N: 10292601)**

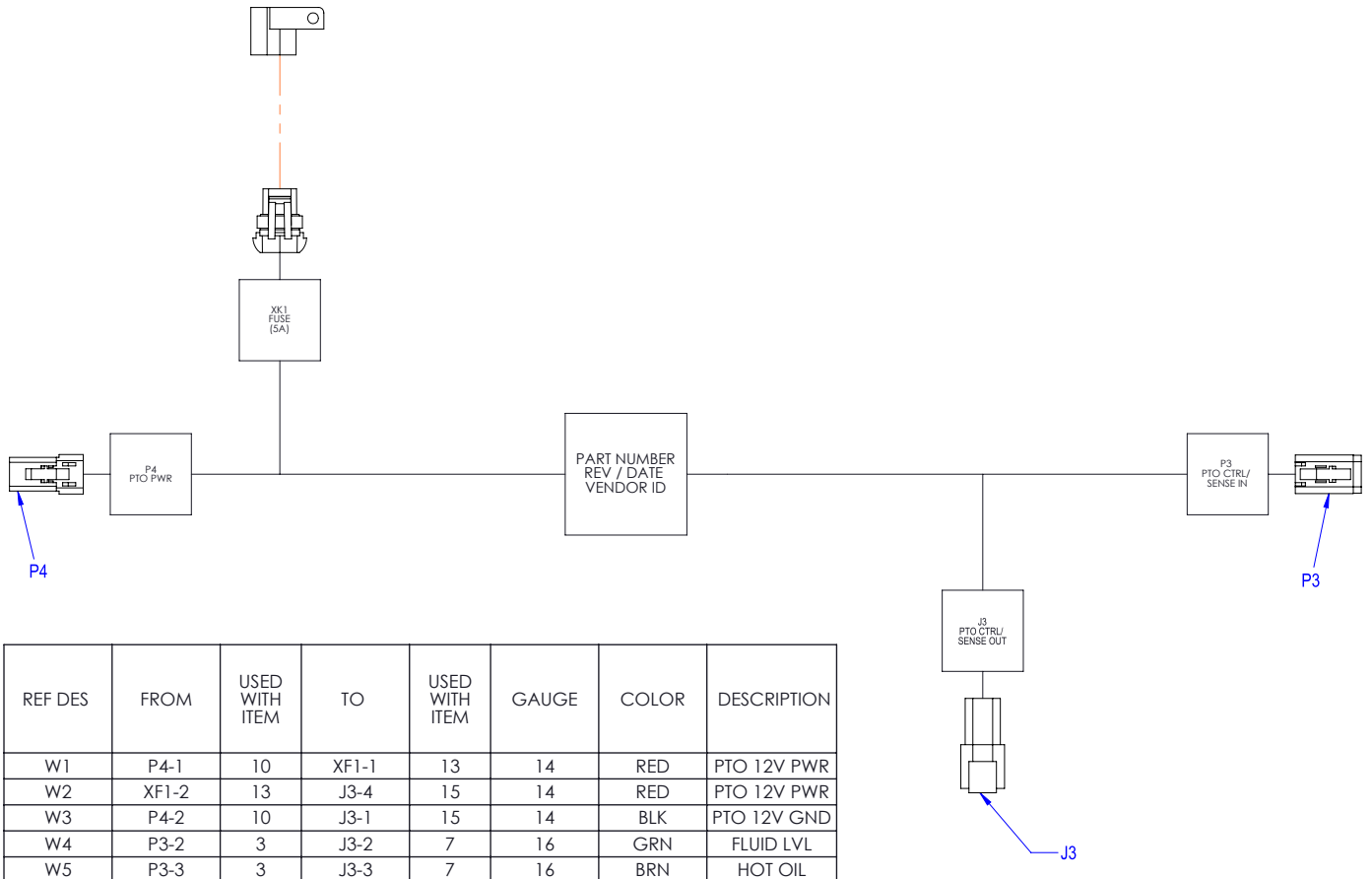

REF DES	FROM	USED WITH ITEM	TO	USED WITH ITEM	GAUGE	COLOR	DESCRIPTION
W1	P4-1	10	XF1-1	13	14	RED	PTO 12V PWR
W2	XF1-2	13	J3-4	15	14	RED	PTO 12V PWR
W3	P4-2	10	J3-1	15	14	BLK	PTO 12V GND
W4	P3-2	3	J3-2	7	16	GRN	FLUID LVL
W5	P3-3	3	J3-3	7	16	BRN	HOT OIL

12V BUS BOX HARNESS (P/N: 10291901)

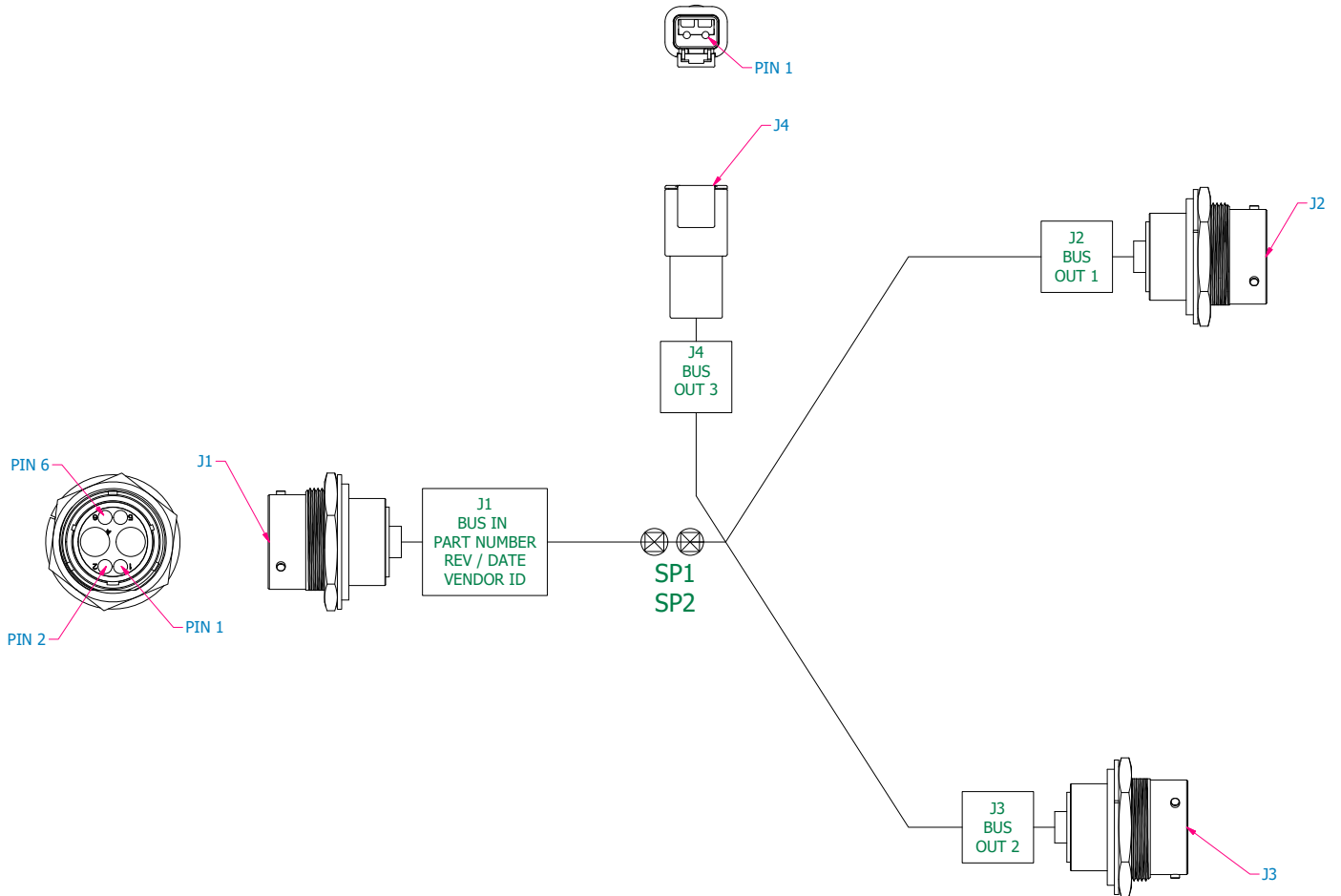

WIRE HOOKUP CHART							
REF-DES	FROM	USED WITH ITEM	TO	USED WITH ITEM	COLOR	GAUGE	DESCRIPTION
W1	J1-3	4	SP1	---	RED	6	12V +
W2	SP1	---	J2-3	4	RED	6	12V +
W3	SP1	---	J3-3	4	RED	6	12V +
W4	SP1	---	J4-1	7	RED	14	12V +
W5	J1-4	4	SP2	---	BLK	6	12V -
W6	SP2	---	J2-4	4	BLK	6	12V -
W7	SP2	---	J3-4	4	BLK	6	12V -
W8	SP2	---	J4-2	7	BLK	14	12V -



**12V AIR PUMP HARNESS (P/N: 10188101)**

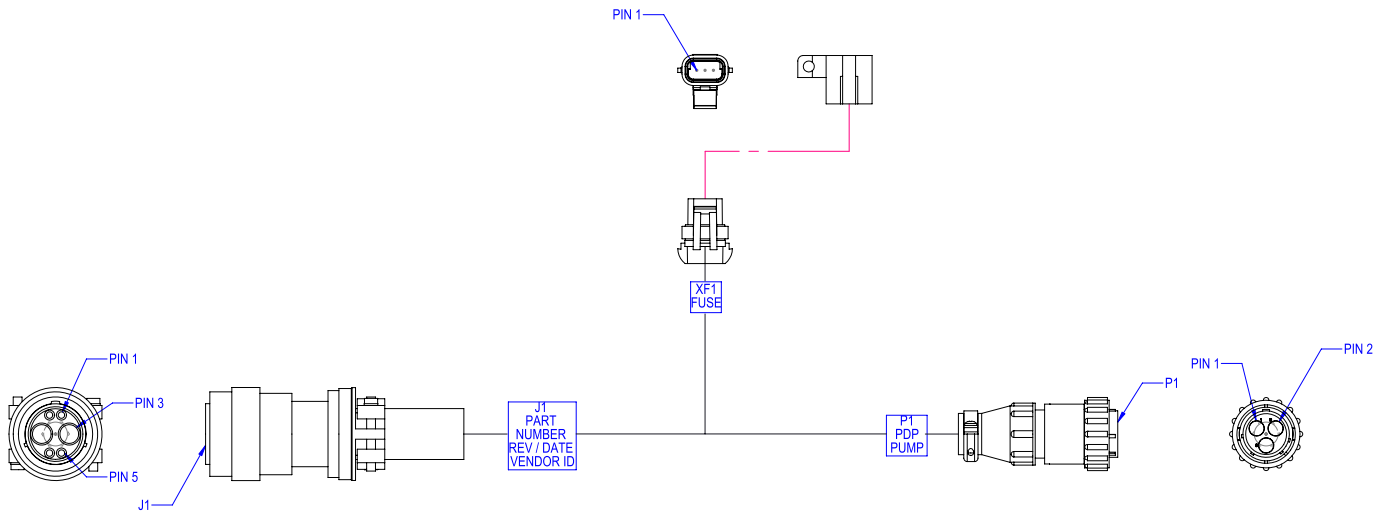

WIRE HOOK UP CHART

REF DES	FROM	USED WITH ITEM	TO	USED WITH ITEM	GAUGE	COLOR	DESCRIPTION
W1	J1-3	5	SP1	---	6	RED	PDP PWR
W2	SP1	---	XF1-1	9	12	RED	PDP PWR
W3	XF1-2	9	SP3	---	12	RED	PDP PWR
W4	SP3	---	P1-1	4	8	RED	PDP PWR
W5	J1-4	5	SP2	---	6	BLK	PDP GND
W6	SP2	---	P1-2	4	8	BLK	PDP GND

**PTO DRAFT LINK HARNESS - 24 ROW 30" AND 36 ROW 20" (P/N: 10803501); 24 ROW 20" (P/N 10803502)**

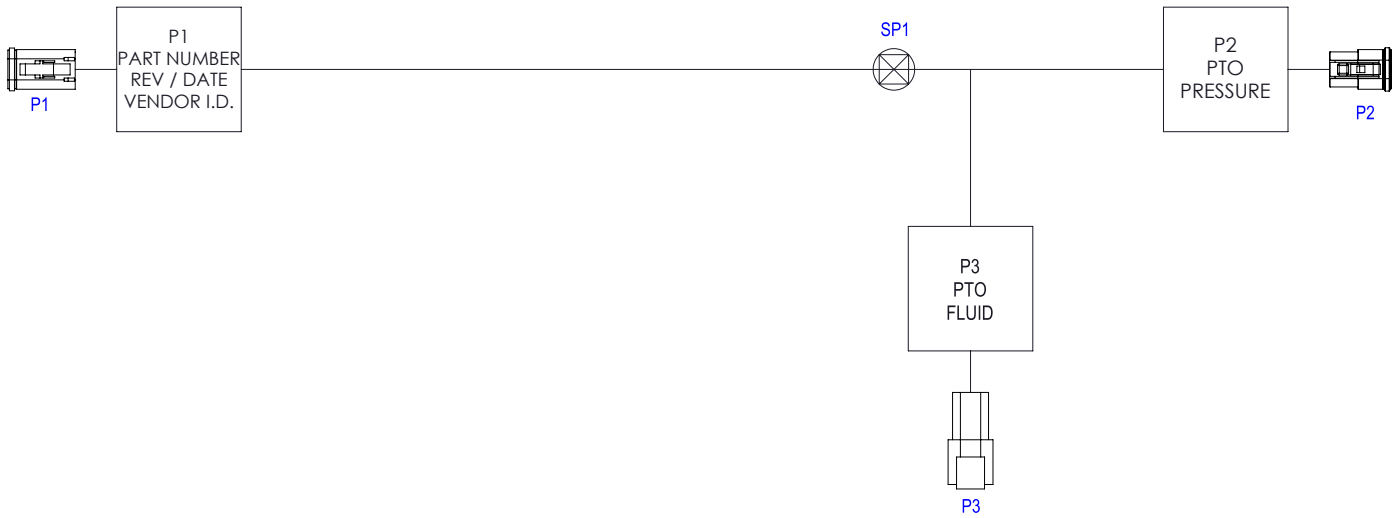

WIRE HOOKUP CHART							
REF DES	FROM	USED W/	TO	USED W/	GAUGE	COLOR	FUNCTION
W1	P1:1	5	P3:2	6	16	GRN	FLUID LEVEL
W2	P1:2	5	P3:3	6	16	BRN	HOT OIL
W3	P1:3	5	P2:C	5	16	YEL	PTO PRESSURE SENSOR (SIG)
W4	P1:4	5	SP1:IN	---	16	BLK	GND
W5	SP1:OUT	---	P2:B	5	16	BLK	PTO PRESSURE SENSOR (GND)
W6	SP1:OUT	---	P3:1	6	16	BLK	GND
W7	P1:5	5	P2:A	5	16	RED	PTO PRESSURE SENSOR (12V +)
W8	P1:6	5	P3:4	6	16	PNK	PTO COOLER (12V+)

**CAMERA POWER HARNESS (P/N: 10269201)**

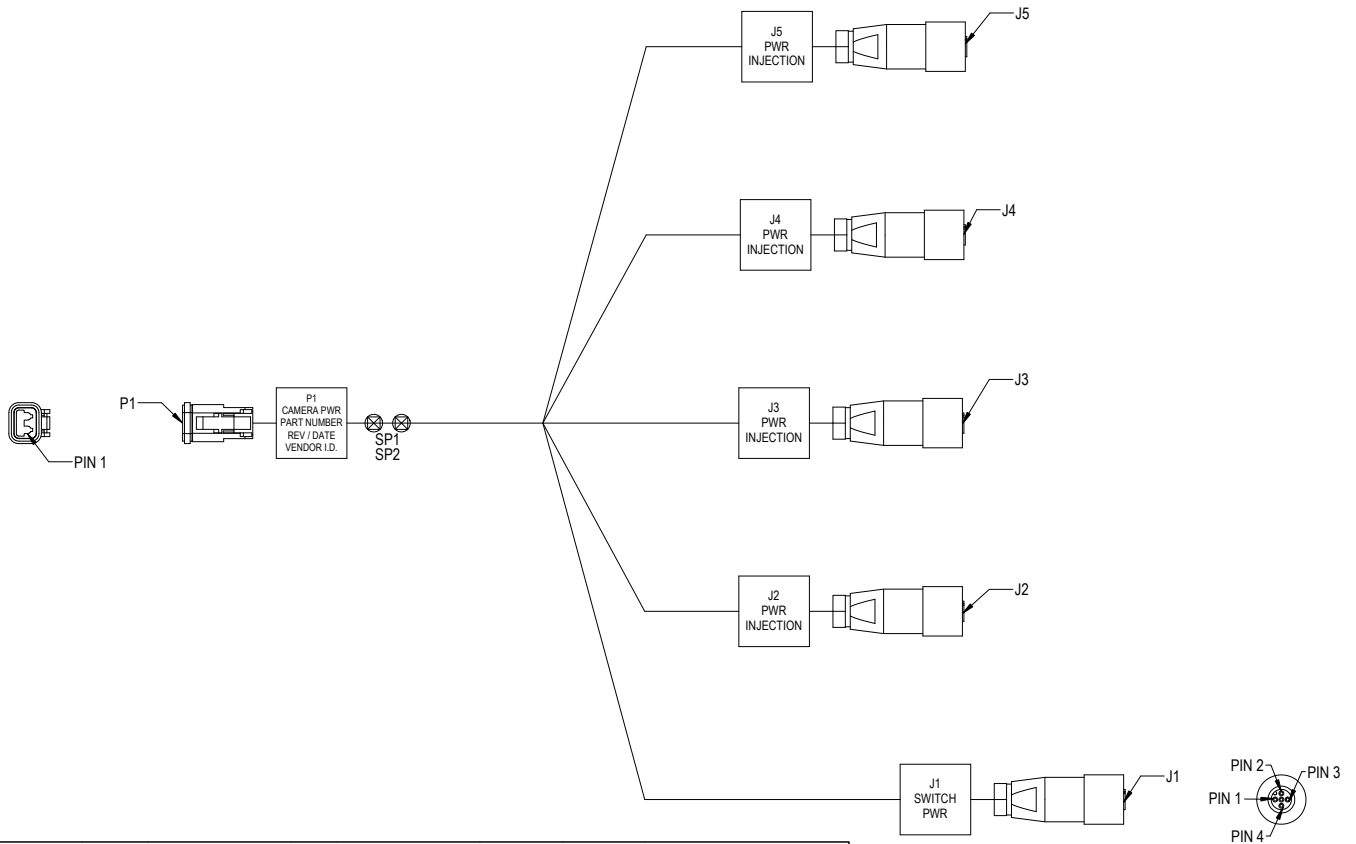

WIRE HOOKUP CHART							
REF DES	FROM	USED W/ ITEM	TO	USED W/ ITEM	GAUGE	COLOR	FUNCTION
W1	P1-2	4	XF1-1	7	16	RED	PWR (+)
W2	SP1	---	J1-3	---	18	RED	SWITCH PWR (+)
W3	SP1	---	J1-4	---	18	RED	SWITCH PWR (+)
W4	SP1	---	J2-2	---	18	RED	CAMERA PWR (+)
W5	SP1	---	J2-3	---	18	RED	CAMERA PWR (+)
W6	SP1	---	J3-2	---	18	RED	CAMERA PWR (+)
W7	SP1	---	J3-3	---	18	RED	CAMERA PWR (+)
W8	SP1	---	J4-2	---	18	RED	CAMERA PWR (+)
W9	SP1	---	J4-3	---	18	RED	CAMERA PWR (+)
W10	SP1	---	J5-2	---	18	RED	CAMERA PWR (+)
W11	SP1	---	J5-3	---	18	RED	CAMERA PWR (+)
W12	P1-1	4	SP2	---	16	BLK	PWR (-)
W13	SP2	---	J1-1	---	18	BLK	SWITCH PWR (-)
W14	SP2	---	J1-2	---	18	BLK	SWITCH PWR (-)
W15	SP2	---	J2-1	---	18	BLK	CAMERA PWR (-)
W16	SP2	---	J2-4	---	18	BLK	CAMERA PWR (-)
W17	SP2	---	J3-1	---	18	BLK	CAMERA PWR (-)
W18	SP2	---	J3-4	---	18	BLK	CAMERA PWR (-)
W19	SP2	---	J4-1	---	18	BLK	CAMERA PWR (-)
W20	SP2	---	J4-4	---	18	BLK	CAMERA PWR (-)
W21	SP2	---	J5-1	---	18	BLK	CAMERA PWR (-)
W22	SP2	---	J5-4	---	18	BLK	CAMERA PWR (-)
W23	XF1-2	7	SP1	--	16	RED	PWR (+)

**PDP CONTROL/SENSOR HARNESS (P/N: 10820101/10820102)**

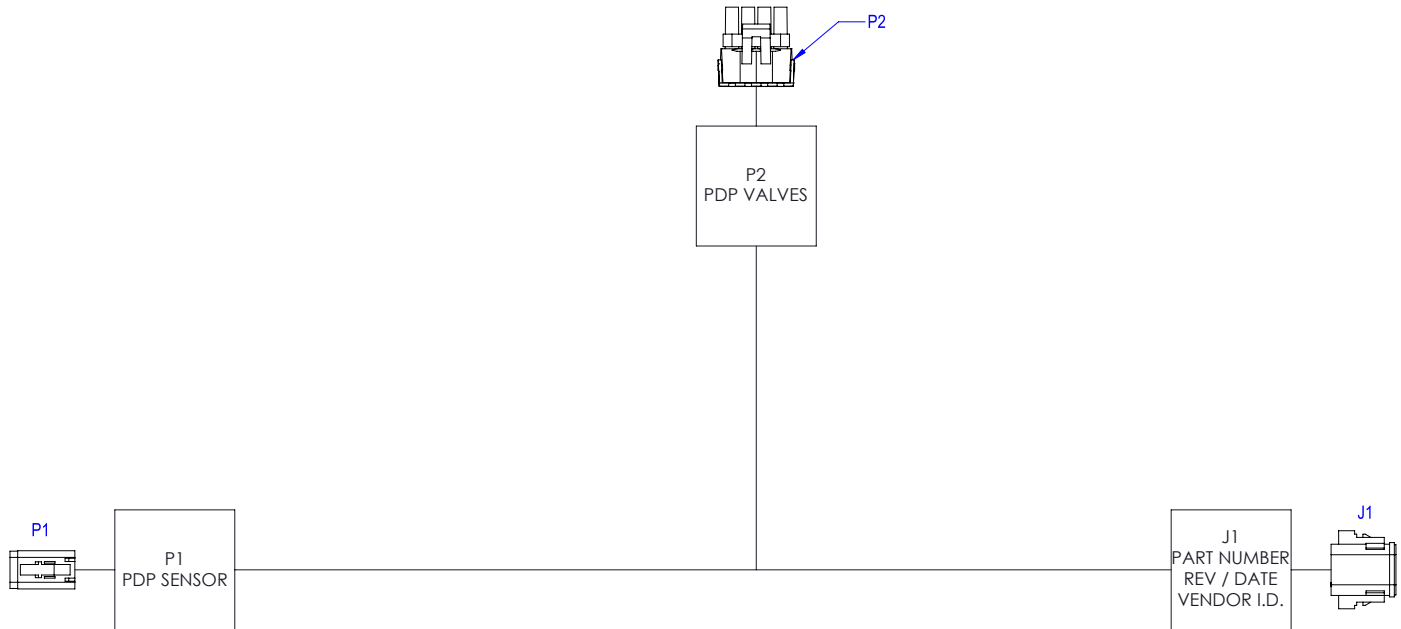

WIRE HOOKUP CHART							
REF DES	FROM	USED W/	TO	USED W/	GAUGE	COLOR	FUNCTION
W1	J1:1	4	P2:A	8	16	RED	PDP INCREASE SOLENOID +
W2	J1:2	4	P2:B	8	16	YEL	PDP INCREASE SOLENOID -
W3	J1:3	4	P2:C	8	16	VLT	PDP DECREASE SOLENOID +
W4	J1:4	4	P2:D	8	16	BRN	PDP DECREASE SOLENOID -
W5	J1:5	4	P1:4	4	18	WHT	PDP SENSOR (SIGNAL)
W6	J1:6	4	P1:1	4	18	BLK	PDP SENSOR (GND)
W7	J1:7	4	P1:2	4	18	ORN	PDP SENSOR (PWR)

**CAN STUB HARNESS (P/N: 10286101/10286102)**



WIRE HOOKUP CHART							
REF DES	FROM	USED WITH ITEM	TO	USED WITH ITEM	GAUGE	COLOR	FUNCTION
W1	J1-3	7	J2-1	4	16	RED	PWR 12VDC
W2	J1-4	7	J2-2	4	16	BLK	GROUND
W3	J1-1	6	J2-3	4	18 TP	YEL	CAN HI
W4	J1-2	6	J2-4	4	18 TP	GRN	CAN LOW

**BULK FILL SCALE CAN CABLE PHD28 HARNESS (P/N: 10242801)**

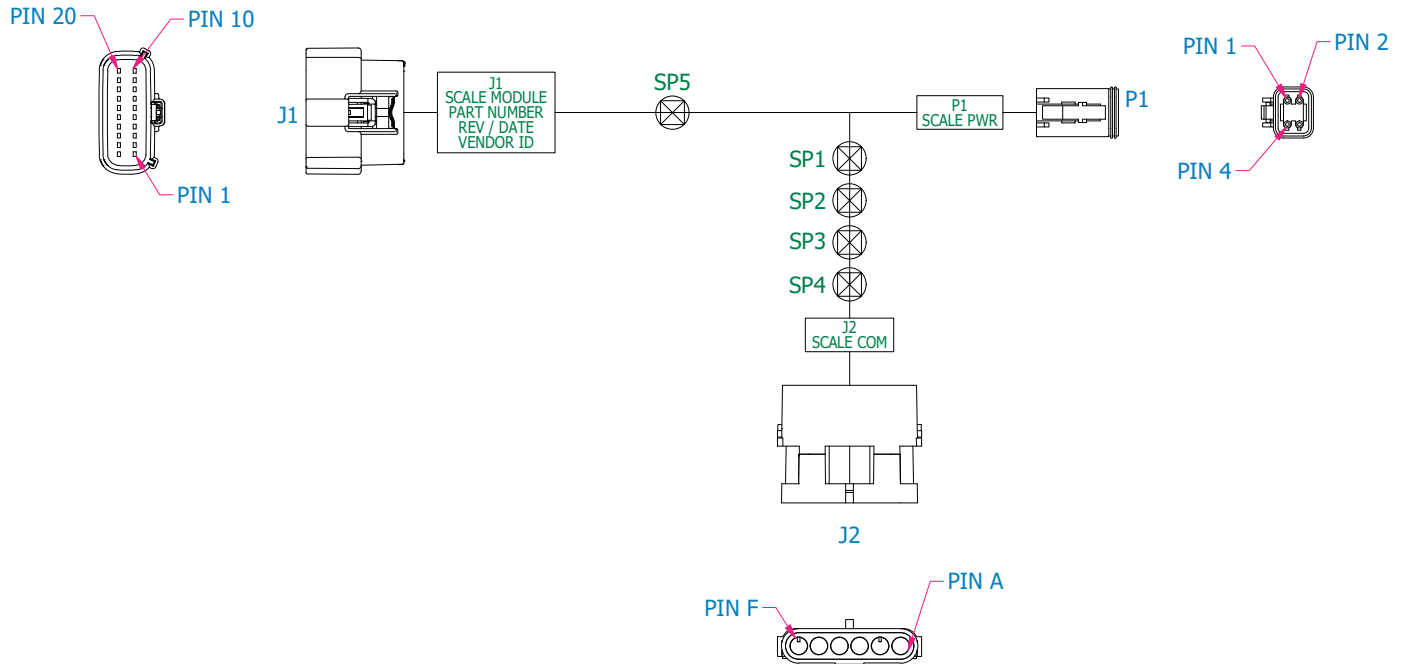

WIRE HOOKUP CHART							
REF DES	FROM	USED WITH ITEM	TO	USED WITH ITEM	GAUGE	COLOR	FUNCTION
W1	J1-10	4	SP1	---	16	RED	PWR 12VDC
W2	SP1	---	P1-1	7	16	RED	PWR 12VDC
W3	SP1	---	J2-A	11	16	RED	PWR 12VDC
W4	J1-9	4	SP2	---	16	BLK	GROUND
W5	SP2	---	P1-2	7	16	BLK	GROUND
W6	SP2	---	J2-B	11	16	BLK	GROUND
W7	J1-8	5	SP5	---	18 TP	YEL	CAN HI
W8	SP3	---	P1-3	7	18 TP	YEL	CAN HI
W9	SP3	---	J2-E	12	18 TP	YEL	CAN HI
W10	J1-7	5	SP4	---	18 TP	GRN	CAN LOW
W11	SP4	---	P1-4	7	18 TP	GRN	CAN LOW
W12	SP4	---	J2-F	12	18 TP	GRN	CAN LOW
W13	SP5	---	SP3	---	18	YEL	CAN HI
W14	SP5	---	J1-5	5	18	YEL	CAN TERM

**INTEGRATED TRUE DEPTH ROW UNIT HARNESS (P/N: 10803401)**

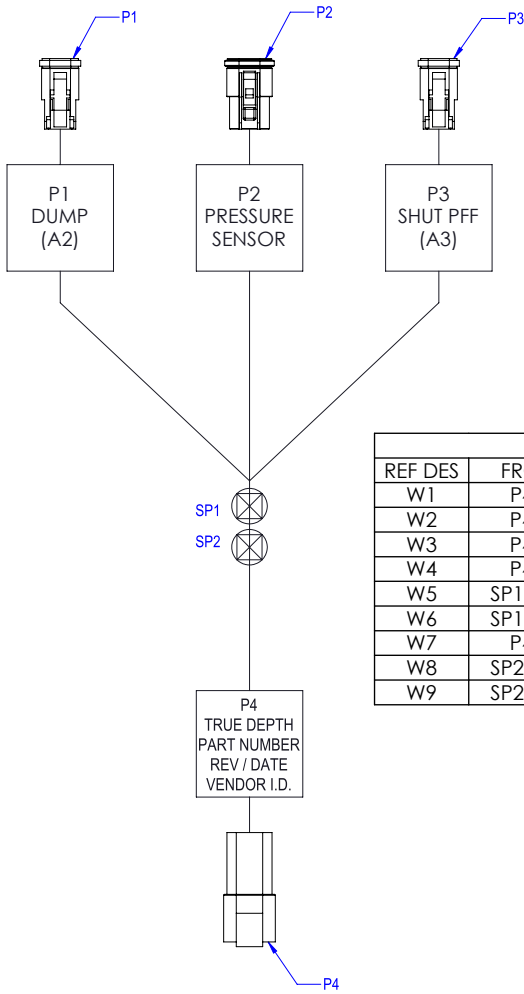

WIRE HOOKUP CHART							
REF DES	FROM	USED W/	TO	USED W/	GAUGE	COLOR	FUNCTION
W1	P4:1	8	P2:C	3	18	WHT	HDP SENSOR (SIGNAL)
W2	P4:2	8	P2:A	3	18	ORN	HDP SENSOR 12V (PWR)
W3	P4:3	8	P2:B	3	18	BLK	HDP SENSOR (GND)
W4	P4:4	8	SP1:IN	---	18	VLT	HDP PWM +
W5	SP1:OUT	---	P1:1	3	18	VLT	HDP PWM + DUMP VALVE
W6	SP1:OUT	---	P3:1	3	18	VLT	HDP PWM + SHUT OFF
W7	P4:5	8	SP2:IN	---	18	BRN	HDP PWM -
W8	SP2:OUT	---	P1:2	3	18	BRN	HDP PWM - DUMP VALVE
W9	SP2:OUT	---	P3:2	3	18	BRN	HDP PWM - SHUT OFF

**YETTER ROW CLEANER COMPRESSOR HARNESS (P/N:10558202)**

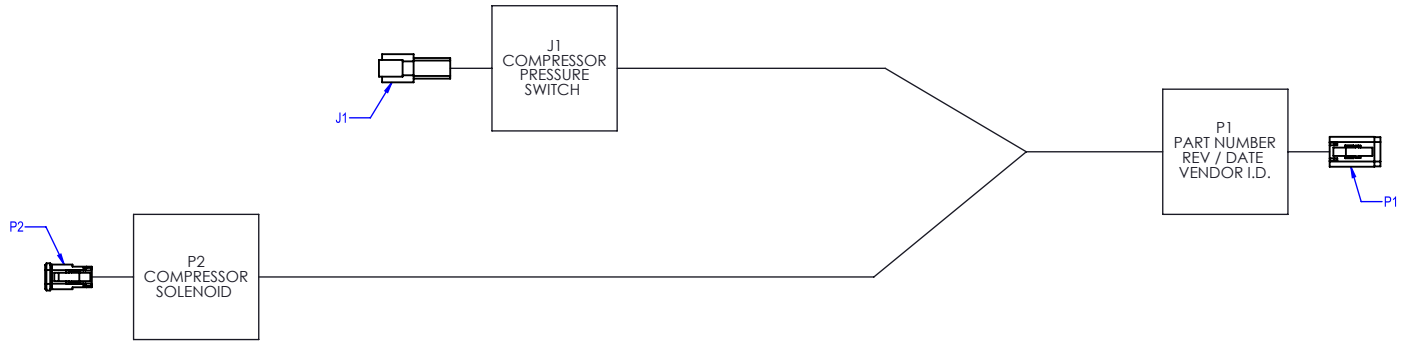

WIRE HOOK UP CHART							
REF DES	FROM	USED W/	TO	USED W/	GAUGE	COLOR	FUNCTION
W1	P1-1	7	J1-1	5	16	RED	COMPRESS SWITCH SUPPLY
W2	P1-2	7	J1-2	5	16	BLU	COMPRESSOR SWITCH SIG
W3	P1-3	7	P2-1	7	16	ORG	COMPRESSOR VALVE SIG
W4	P1-4	7	P2-2	7	16	BLK	COMPRESSOR VALVE GROUND

**YETTER ROW CLEANER PWR/CAN HARNESS (P/N:10631701)**

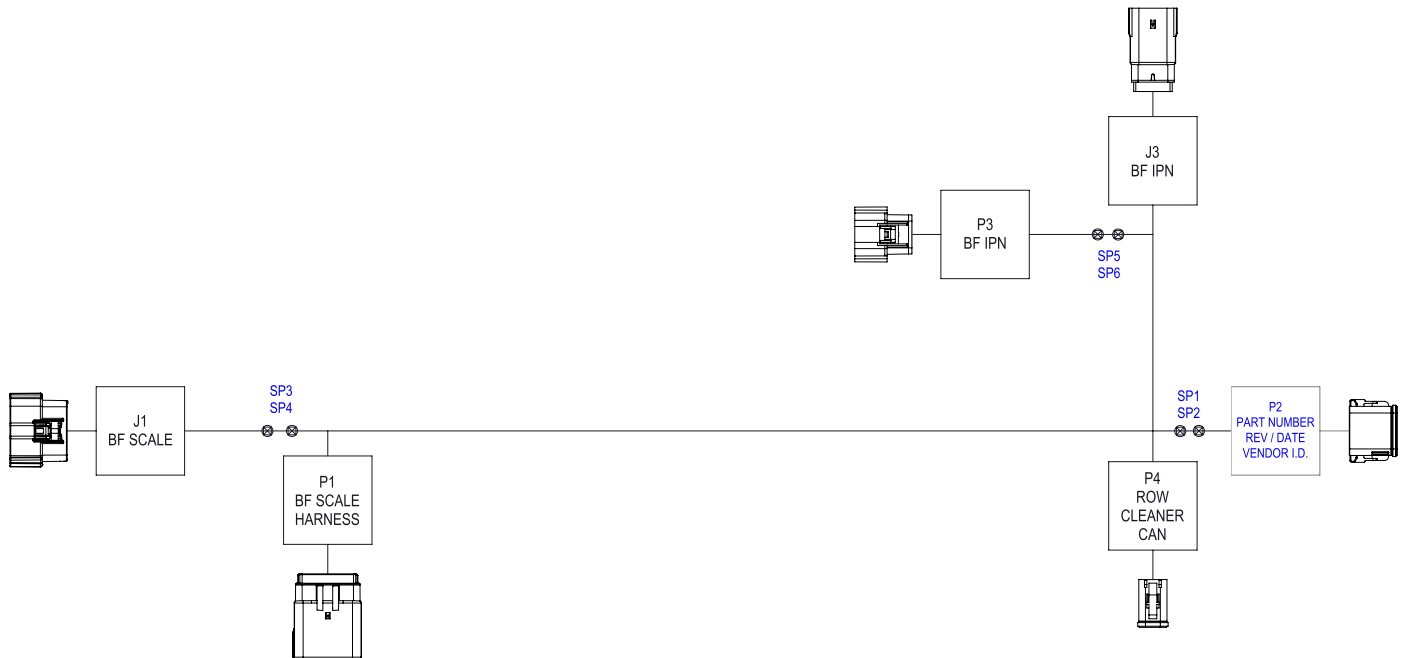

WIRE HOOKUP CHART												
REF DES	FROM	TO	GAUGE	COLOR	DESCRIPTION	REF DES	FROM	TO	GAUGE	COLOR	DESCRIPTION	
106317 W1	P1-10	J1-10	18	RD	SCALE 12V (PWR)	106317 W17	P3-1	SP5-IN	16	RD	12V (PWR)	
106317 W2	P1-9	J1-9	18	BK	SCALE 12V (GND)	106317 W18	J3-1	SP5-OUT	16	RD	IPN 12V (PWR)	
106317 W3	P1-8	SP3-IN	18(TP)	YL	CAN HI	106317 W19	SP1-IN	SP5-OUT	16	RD	ROW CLEANER 12V (PWR)	
106317 W4	P1-7	SP4-IN		GN	CAN LOW	106317 W20	P3-2	SP6-IN	16	BK	12V (GND)	
106317 W5	J1-8	SP3-IN	18(TP)	YL	CAN HI	106317 W21	J3-2	SP6-OUT	16	BK	IPN 12V (GND)	
106317 W6	J1-7	SP4-IN		GN	CAN LOW	106317 W22	SP2-IN	SP6-OUT	16	BK	ROW CLEANER 12V (GND)	
106317 W7	P4-4	SP3-IN	18(TP)	YL	CAN HI	106317 W23	P3-3	J3-3	18	RD	IPN 12V (PWR)	
106317 W8	P4-5	SP4-OUT		GN	CAN LOW	106317 W24	P3-4	J3-4	18	BK	IPN 12V (GND)	
106317 W9	P2-1	SP1-OUT	18	RD	ROW CLEANER 12V (PWR)	106317 W25	P3-5	J3-5	18	BK	STRAPPING	
106317 W10	P2-2	SP1-OUT	18	RD	ROW CLEANER 12V (PWR)	106317 W26	P3-6	J3-6	18	BK	STRAPPING	
106317 W11	P2-3	SP1-OUT	18	RD	ROW CLEANER 12V (PWR)	106317 W27	P3-7	J3-7	18	BK	STRAPPING	
106317 W12	P2-12	SP1-OUT	18	RD	ROW CLEANER 12V (PWR)	106317 W28	P3-8	J3-8	18	BK	STRAPPING	
106317 W13	P2-4	SP2-OUT	18	BK	ROW CLEANER 12V (GND)	106317 W29	P3-9	J3-9	18	BK	STRAPPING	
106317 W14	P2-5	SP2-OUT	18	BK	ROW CLEANER 12V (GND)	106317 W30	P3-10	J3-10	18	BK	STRAPPING	
106317 W15	P2-6	SP2-OUT	18	BK	ROW CLEANER 12V (GND)	106317 W31	P3-11	J3-11	18	BK	STRAPPING	
106317 W16	P2-11	SP2-OUT	18	BK	ROW CLEANER 12V (GND)	106317 W32	P3-12	J3-12	18	BK	STRAPPING	



TRUE SPEED PULL ROW UNIT W/IPP HARNESS (P/N: 10916001)

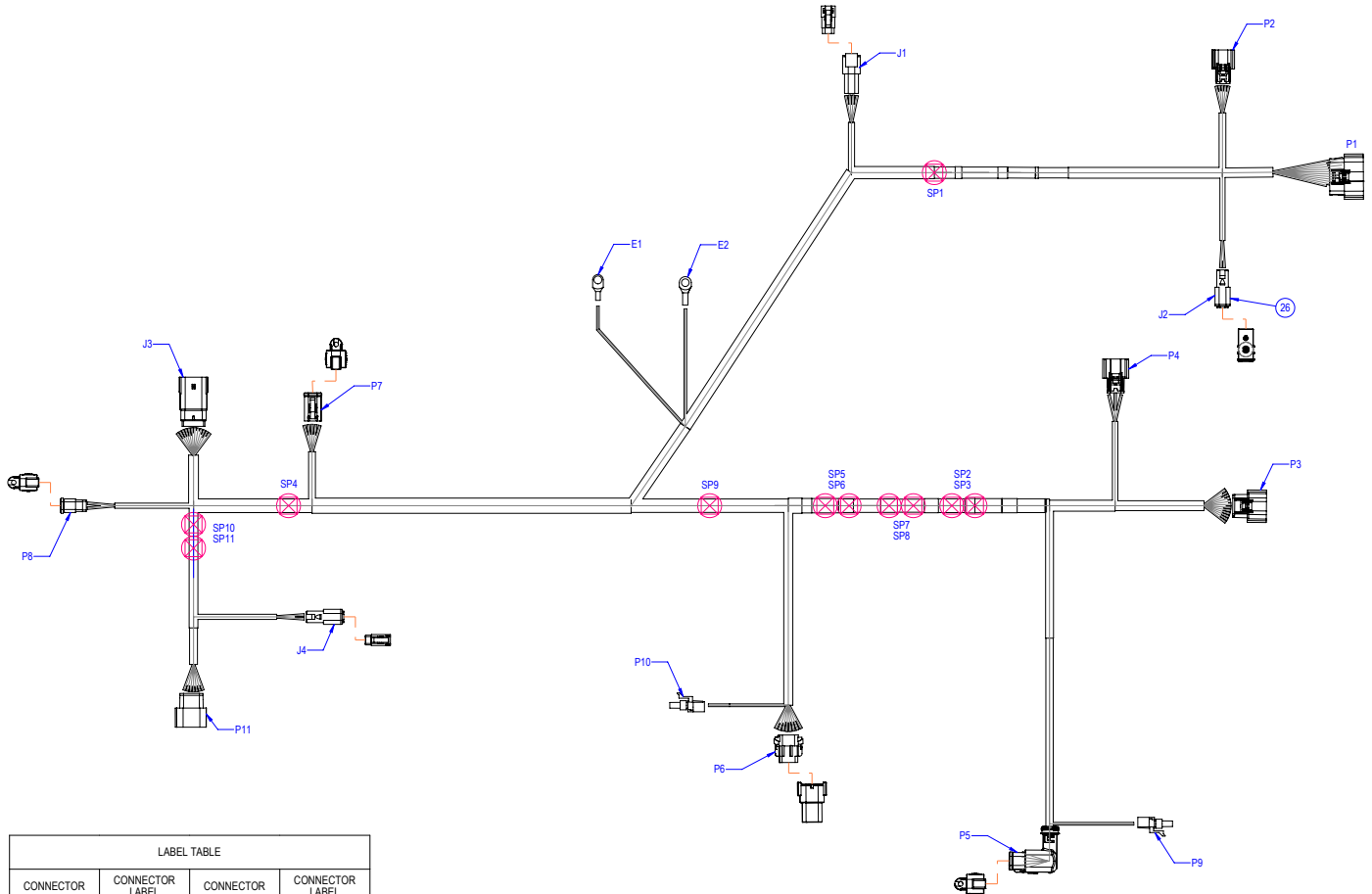

LABEL TABLE			
CONNECTOR	CONNECTOR LABEL	CONNECTOR	CONNECTOR LABEL
P1	RU IPN J7	P6	SEED SENSOR
P2	RU IPN J6	P7	FERTILIZER
P3	RU IPN J3	P8	TRUE DEPTH SOLENOID
P4	RU IPN J4	P9	BRAIDED ESD CABLE
J1	LINK SENSOR	P10	BRAIDED ESD CABLE
J2	MANUAL RUN	P11	RU IPP
J3	IPN PWR	E1	GND
J4	CAN TERM	E2	BRAIDED ESD CABLE
P5	SEED METER	HARNESS LABEL	PART NUMBER REV/DATE VENDOR I.D.

WIRE HOOKUP CHART															
REF DES	FROM	USED W/	TO	USED W/	GAUGE	COLOR	FUNCTION	REF DES	FROM	USED W/	TO	USED W/	GAUGE	COLOR	FUNCTION
W1	P1:1	29	P11:1	29	18 (TP)	ORG	RS232 RX	W30	SP2:OUT	---	P5:3	25	18 (TP)	YEL	CAN H
W2	P1:2	29	P11:2	29	18 (TP)	BRN	RS232 TX	W31	SP3:OUT	---	P5:4	25	18 (TP)	GRN	CAN L
W3	P1:3	29	P7:5	25	18	RED	FERT ROW CUTOFF VALVE (PWR)	W32	P2:3	29	SP4:IN	---	18	RED	IPP / FERT FLOW SENSOR (PWR)
W4	P1:4	29	P7:6	25	18	BLK	FERT ROW CUTOFF VALVE (GND)	W33	SP4:OUT	---	P7:1	25	18	RED	FERT FLOW SENSOR (PWR)
W5	P1:7	29	P8:1	25	18	BLU	TRUE DEPTH CYLINDER PWM +	W34	SP4:OUT	---	P11:12	29	18	RED	IPP PWR+
W6	P1:8	29	P8:2	25	18	BLU	TRUE DEPTH CYLINDER PWM -	W35	P2:4	29	P11:6	29	18	BLK	IPP PWR-
W7	P4:8	29	P7:3	25	18	BLU	FERT FLOW SENSOR (SIGNAL)	W36	P2:5	29	P11:11	29	18	BLU	IPP SOFTWARE UPDATE
W8	P1:16	29	J1:2	23	18	WHT	TRUE DEPTH LINK SENSOR (SIGNAL)	W37	J3:2	27	SP6:IN	---	16	BLK	24V IPN GND
W9	P1:19	29	SP1:IN	---	18	GRY	FERT / TRUE DEPTH SENSOR (GND)	W38	SP6:OUT	---	P3:2	31	16	BLK	24V IPN GND
W10	SP1:OUT	---	P7:2	25	18	GRY	FERT FLOW SENSOR (GND)	W39	SP6:OUT	---	P6:2	35	16	BLK	BELT BLDC DRIVER (24V GND)
W11	SP1:OUT	---	J1:4	23	18	GRY	TRUE DEPTH SENSOR (GND)	W40	J3:3	27	SP7:IN	---	16	RED	24V IPN PWR
W12	P4:5	29	P8:5	35	18	PNK	SEED SENSOR (PWR)	W41	SP7:OUT	---	P3:3	31	16	RED	24V IPN PWR
W13	P4:6	29	P6:8	35	18	GRY	SEED SENSOR (GND)	W42	SP7:OUT	---	P5:1	25	16	RED	METER BLDC DRIVER (24V PWR)
W14	J3:1	27	SP5:IN	---	16	RED	24V IPN PWR	W43	J3:4	27	SP8:IN	---	16	BLK	24V IPN GND
W15	SP5:OUT	---	P3:1	31	16	RED	24V IPN PWR	W44	SP8:OUT	---	P3:4	31	16	BLK	24V IPN GND
W16	SP5:OUT	---	P6:1	35	16	RED	BELT BLDC DRIVER (24V PWR)	W45	SP8:OUT	---	P5:2	25	16	BLK	METER BLDC DRIVER (24V GND)
W17	J3:5	27	P3:5	29	20	YEL	IPN STRAPPING	W46	SP8:OUT	---	P5:6	25	16	BLK	METER BLDC DRIVER (STRAPPING)
W18	J3:6	27	P3:6	29	20	ORG	IPN STRAPPING	W47	E2	---	SP9:IN	---	ESD	---	BRAIDED ESD CABLE
W19	J3:7	27	P3:7	29	20	WHT	IPN STRAPPING	W48	SP9:OUT	---	P10:1	37	ESD	---	BRAIDED SEED TUBE ESD CABLE
W20	J3:8	27	P3:8	29	20	GRN	IPN STRAPPING	W49	SP9:OUT	---	P9:1	37	ESD	---	BRAIDED METER ESD CABLE
W21	J3:9	27	P3:9	29	20	BLU	IPN STRAPPING	W50	P6:7	35	SP10:IN	---	18 (TP)	YEL	CAN H
W22	J3:10	27	P3:10	29	20	BLU	IPN STRAPPING	W51	P6:8	35	SP11:IN	---	18 (TP)	GRN	CAN L
W23	J3:11	27	P3:11	29	20	GRY	IPN STRAPPING (PARITY)	W52	SP10:OUT	---	J4:1	23	18 (TP)	YEL	TERM (CAN H)
W24	J3:12	27	P3:12	29	20	BRN	IPN STRAPPING (GND)	W53	SP11:OUT	---	J4:2	23	18 (TP)	GRN	TERM (CAN L)
W25	J1:1	23	P1:20	29	18	PNK	TRUE DEPTH LINK SENSOR (PWR)	W54	SP10:OUT	---	P11:5	29	18 (TP)	YEL	IPP (CAN H)
W26	P2:1	29	SP2:IN	---	18 (TP)	YEL	IPN (CAN H)	W55	SP11:OUT	---	P11:4	29	18 (TP)	GRN	IPP (CAN L)
W27	P2:2	29	SP3:IN	---	18 (TP)	GRN	IPN (CAN L)	W56	E1	---	J1:3	23	18	GRN	TRUE DEPTH LINK SENSOR (SHIELD)
W28	SP2:OUT	---	P6:3	35	18 (TP)	YEL	SEED SENSOR (CAN H)	W57	J2:2	28	P1:14	29	18	BRN	MANUAL RUN (PWR)
W29	SP3:OUT	---	P6:4	35	18 (TP)	GRN	SEED SENSOR (CAN L)	W58	J2:1	28	P1:17	29	18	GRY	MANUAL RUN (GND)

TRUE RATE PULL ROW UNIT W/IPP HARNESS (P/N: 10915901)

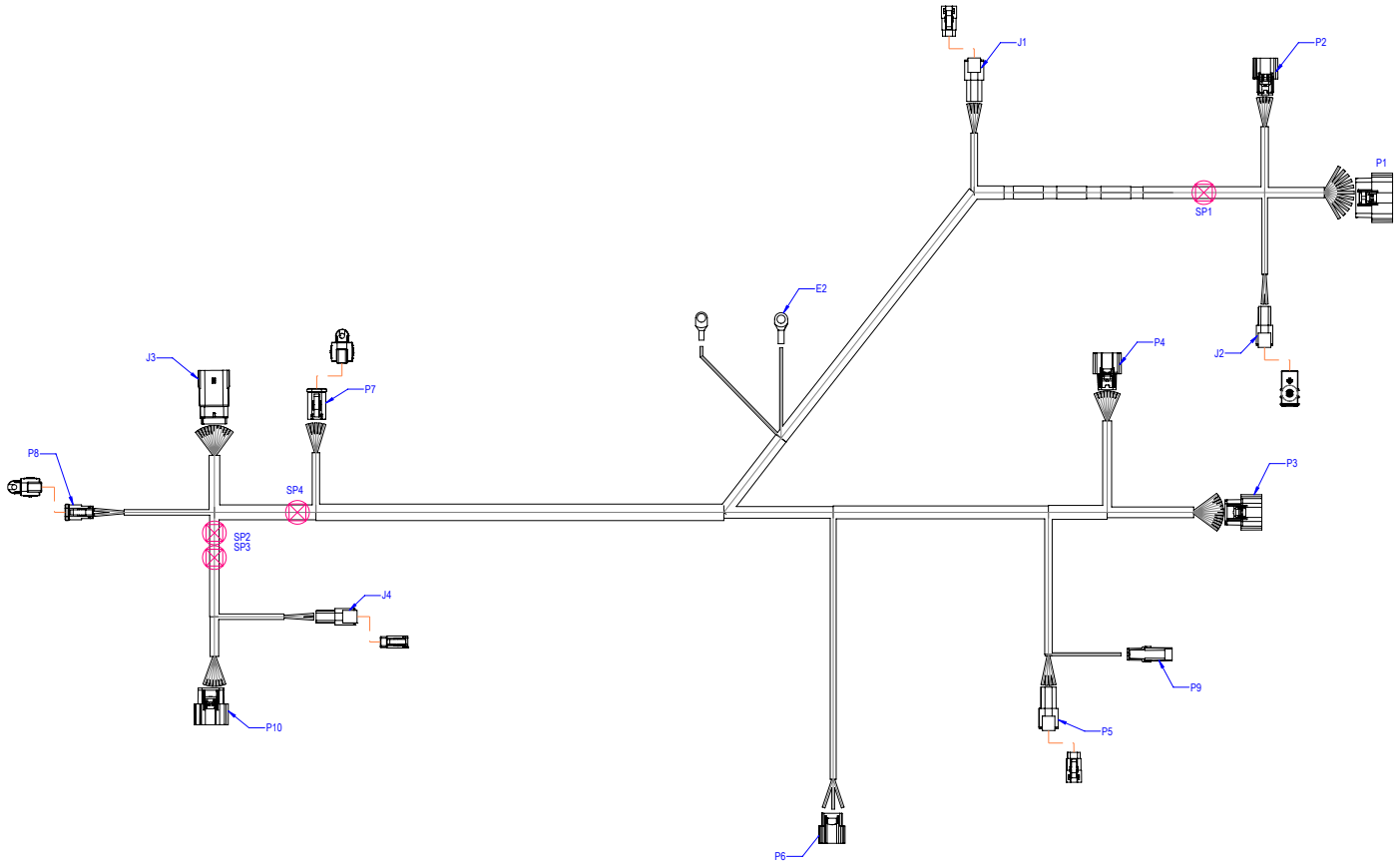

LABEL TABLE			
CONNECTOR	CONNECTOR LABEL	CONNECTOR	CONNECTOR LABEL
P1	RU IPN J7	P5	SEED METER
P2	RU IPN J6	P6	SEED SENSOR
P3	RU IPN J3	P7	FERTILIZER
P4	RU IPN J4	P8	TRUE DEPTH SOLENOID
J1	LINK SENSOR	P9	BRAIDED ESD CABLE
J2	MANUAL RUN	P10	RU IPP
J3	IPN PWR	E1	GND
J4	CAN TERM	E2	BRAIDED ESD CABLE
HARNESS LABEL	PART NUMBER REV / DATE VENDOR I.D.		

WIRE HOOKUP CHART															
REF DES	FROM	USED W/	TO	USED W/	GAUGE	COLOR	FUNCTION	REF DES	FROM	USED W/	TO	USED W/	GAUGE	COLOR	FUNCTION
W1	P1:3	26	P7:6	23	18	RED	FERT ROW CUTOFF VALVE (PWR)	W24	J3:11	24	P3:11	26	20	GRY	IPN STRAPPING (PARITY)
W2	P1:4	26	P7:6	23	18	BLK	FERT ROW CUTOFF VALVE (GND)	W25	J3:12	24	P3:12	26	20	BRN	IPN STRAPPING (GND)
W3	P1:7	26	P8:1	23	18	VLТ	TRUE DEPTH CYLINDER PWM+	W26	J1:3	20	E1	---	18	GRN	TRUE DEPTH LINK SENSOR (SHIELD)
W4	P1:8	26	P8:2	23	18	BLU	TRUE DEPTH CYLINDER PWM-	W27	P9:1	34	E2	---	ESD	---	BRAIDED ESD CABLE
W5	P4:8	26	P7:3	23	18	VLТ	FERT FLOW SENSOR (SIGNAL)	W28	P1:14	26	J2:2	25	18	BRN	MANUAL RUN (PWR)
W6	P1:16	26	J1:2	20	18	WHT	TRUE DEPTH LINK SENSOR (SIGNAL)	W29	P1:17	26	J2:1	25	18	GRY	MANUAL RUN (GND)
W7	P1:19	26	SP1:IN	---	18	GRY	FERT / TRUE DEPTH SENSOR (GND)	W30	P4:1	26	P5:1	29	18	RED	SEED METER MOTOR 1+
W8	SP1:OUT	---	P7:2	23	18	GRY	FERT FLOW SENSOR (GND)	W31	P4:2	26	P5:2	29	18	WHT	SEED METER MOTOR 1-
W9	SP1:OUT	---	J1:4	20	18	GRY	TRUE DEPTH LINK SENSOR (GND)	W32	P4:4	26	P5:3	29	18	GRN	SEED METER MOTOR 2+
W10	P1:20	26	J1:1	20	18	PNK	TRUE DEPTH LINK SENSOR (PWR)	W33	P4:3	26	P5:4	29	18	BLK	SEED METER MOTOR 2-
W11	P2:3	26	SP4:IN	---	18	RED	IPP / FERT FLOW SENSOR (PWR)	W34	P4:5	26	P6:1	31	18	RED	SEED SENSOR (PWR)
W12	SP4:OUT	---	P7:1	23	18	RED	FERT FLOW SENSOR (PWR)	W35	P4:6	26	P6:6	31	18	BLK	SEED SENSOR (GND)
W13	SP4:OUT	---	P10:12	26	18	RED	IPP PWR+	W36	P4:7	26	P6:2	31	18	BLU	SEED SENSOR (LIN)
W14	J3:1	24	P3:1	28	16	RED	24V IPN PWR	W37	P1:1	26	P10:1	26	18 (TP)	ORG	RS232 RX
W15	J3:2	24	P3:2	28	16	BLK	24V IPN GND	W38	P1:2	26	P10:2	26	18	BRN	RS232 TX
W16	J3:3	24	P3:3	28	16	RED	24V IPN PWR	W39	P2:1	26	SP3:IN	---	18 (TP)	YEL	IPN (CAN H)
W17	J3:4	24	P3:4	28	16	BLK	24V IPN PWR	W40	P2:2	26	SP2:IN	---	18 (TP)	GRN	IPN (CAN L)
W18	J3:5	24	P3:5	26	20	YEL	IPN STRAPPING	W41	SP3:OUT	---	J4:1	20	18 (TP)	YEL	TERM (CAN H)
W19	J3:6	24	P3:6	26	20	ORG	IPN STRAPPING	W42	SP2:OUT	---	J4:2	20	18 (TP)	GRN	TERM (CAN L)
W20	J3:7	24	P3:7	26	20	WHT	IPN STRAPPING	W43	SP3:OUT	---	P10:5	26	18 (TP)	YEL	IPP (CAN H)
W21	J3:8	24	P3:8	26	20	GRN	IPN STRAPPING	W44	SP2:OUT	---	P10:4	26	18 (TP)	GRN	IPP (CAN L)
W22	J3:9	24	P3:9	26	20	BLU	IPN STRAPPING	W45	P2:5	26	P10:11	26	18	BLU	IPP SOFTWARE UPDATE
W23	J3:10	24	P3:10	26	20	VLТ	IPN STRAPPING	W46	P2:4	26	P10:6	26	18	BLK	IPP PWR-

TRUE SPEED PULL ROW UNIT HARNESS (P/N:10915801)

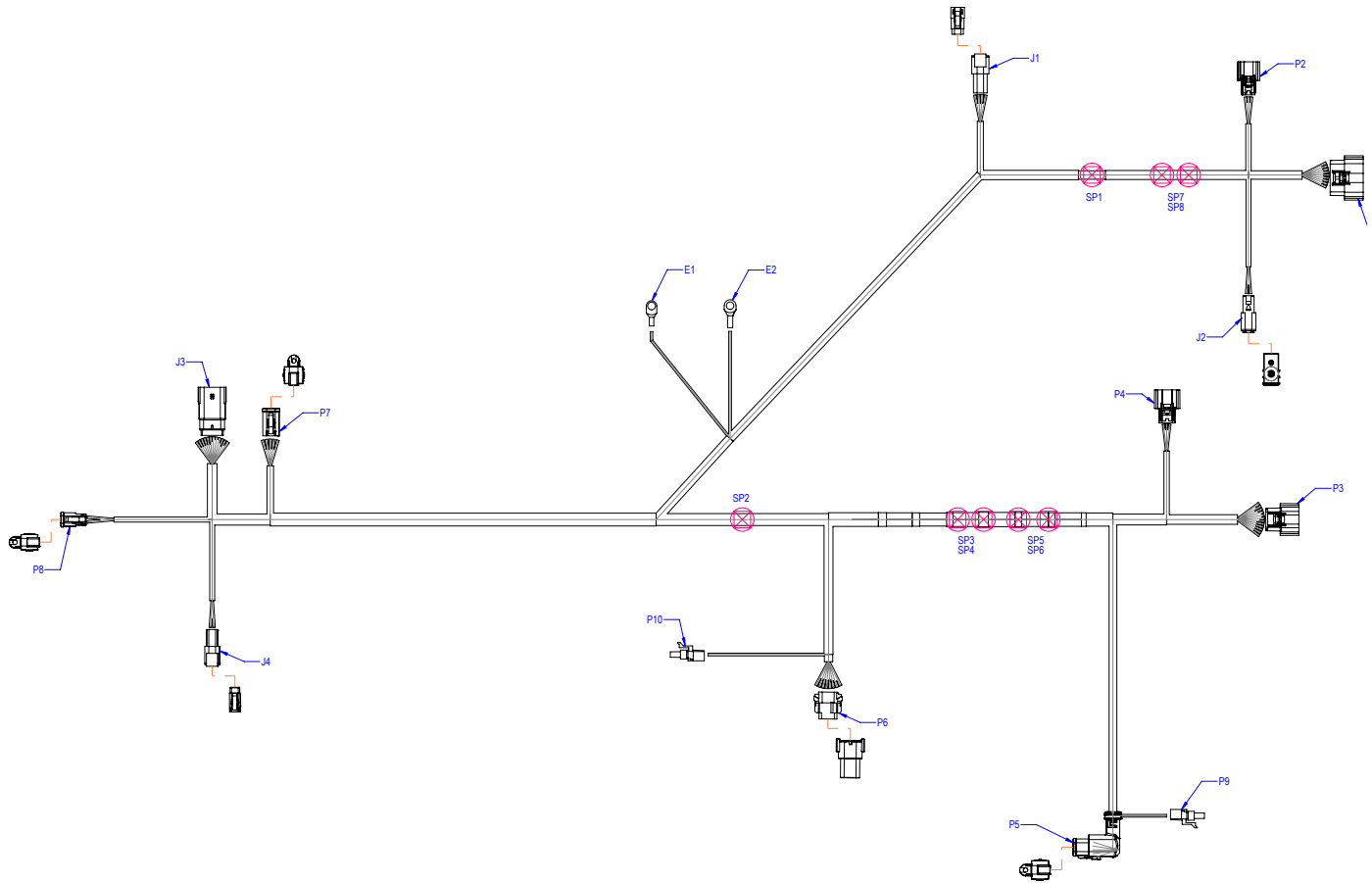

LABEL TABLE			
CONNECTOR	CONNECTOR LABEL	CONNECTOR	CONNECTOR LABEL
P1	RU IPN J7	P5	SEED METER
P2	RU IPN J6	P6	SEED SENSOR
P3	RU IPN J3	P7	FERTILIZER
P4	RU IPN J4	P8	TRUE DEPTH SOLENOID
J1	LINK SENSOR	P9	BRAIDED ESD CABLE
J2	MANUAL RUN	P10	BRAIDED ESD CABLE
J3	IPN PWR	E1	GND
J4	CAN TERM	E2	BRAIDED ESD CABLE
HARNESS LABEL	PART NUMBER REV / DATE VENDOR I.D.		

WIRE HOOKUP CHART															
REF DES	FROM	USED W/	TO	USED W/	GAUGE	COLOR	FUNCTION	REF DES	FROM	USED W/	TO	USED W/	GAUGE	COLOR	FUNCTION
W1	P1:3	28	P7:5	25	18	RED	FERT ROW CUT OFF VALVE (PWR)	W25	SP5:OUT	---	P5:1	25	16	RED	METER BLDC DRIVER (24V PWR)
W2	P1:4	28	P7:6	25	18	BLK	FERT ROW CUT OFF VALVE (GND)	W26	P1:14	28	J2:2	39	18	BRN	MANUAL RUN (PWR)
W3	P1:7	28	P8:1	25	18	VLT	TRUE DEPTH CYLINDER PWM+	W27	P1:17	28	J2:1	39	18	GRY	MANUAL RUN (GND)
W4	P1:8	28	P8:2	25	18	BLU	TRUE DEPTH CYLINDER PWM-	W28	J3:4	26	SP6:IN	---	16	BLK	24V IPN GND
W5	P4:8	28	P7:3	25	18	VLT	FERT FLOW SENSOR (SIGNAL)	W29	E2	---	SP2:IN	---	---	ESD	BRAIDED ESD CABLE
W6	P1:16	28	J1:2	22	18	WHI	TRUE DEPTH LINK SENSOR (SIGNAL)	W30	SP6:OUT	---	P5:2	25	16	BLK	METER BLDC DRIVER (24V GND)
W7	P1:19	28	SP1:IN	---	18	GRY	FERT / TRUE DEPTH SENSOR (GND)	W31	SP6:OUT	---	P3:4	30	16	BLK	24V IPN GND
W8	SP1:OUT	---	P7:2	25	18	GRY	FERT FLOW SENSOR (GND)	W32	J3:5	26	P3:5	28	20	YEL	IPN STRAPPING
W9	SP1:OUT	---	J1:4	22	18	GRY	TRUE DEPTH LINK SENSOR (GND)	W33	J3:6	26	P3:6	28	20	ORG	IPN STRAPPING
W10	P1:20	28	J1:1	22	18	PNK	TRUE DEPTH LINK SENSOR (PWR)	W34	J3:7	26	P3:7	28	20	WHT	IPN STRAPPING
W11	P2:3	28	P7:1	25	18	RED	FERT FLOW SENSOR (PWR)	W35	J3:8	26	P3:8	28	20	GRN	IPN STRAPPING
W12	P2:1	28	SP7:IN	---	18 (TP)	YEL	IPN (CAN H)	W36	J3:9	26	P3:9	28	20	BLU	IPN STRAPPING
W13	P2:2	28	SP8:IN	---	18 (TP)	GRN	IPN (CAN L)	W37	J3:10	26	P3:10	28	20	VLT	IPN STRAPPING
W14	P4:5	28	P6:5	32	18	PNK	SEED SENSOR (PWR)	W38	J3:11	26	P3:11	28	20	GRY	IPN STRAPPING (PARITY)
W15	P4:6	28	P6:6	32	18	GRY	SEED SENSOR (GND)	W39	J3:12	26	P3:12	28	20	BRN	IPN STRAPPING (GND)
W16	J3:1	26	SP3:IN	---	16	RED	24V IPN PWR	W40	SP7:OUT	---	P5:3	25	18 (TP)	YEL	CAN H
W17	SP3:OUT	---	P3:1	30	16	RED	24V IPN PWR	W41	SP8:OUT	---	P5:4	25	18 (TP)	GRN	CAN L
W18	SP3:OUT	---	P6:1	32	16	RED	BELT BLDC DRIVER (24V PWR)	W42	SP7:OUT	---	P6:3	32	18 (TP)	YEL	SEED SENSOR (CAN H)
W19	SP4:OUT	---	P6:2	32	16	BLK	BELT BLDC DRIVER (24V GND)	W43	SP8:OUT	---	P6:4	32	18 (TP)	GRN	SEED SENSOR (CAN L)
W20	SP4:OUT	---	P3:2	30	16	BLK	24V IPN GND	W44	J4:1	22	P6:7	32	18 (TP)	YEL	CAN H
W21	J3:2	26	SP4:IN	---	16	BLK	24V IPN GND	W45	J4:2	22	P6:8	32	18 (TP)	GRN	CAN L
W22	J3:3	26	SP5:IN	---	16	RED	24V IPN PWR	W46	SP2:OUT	---	P9:1	37	ESD	---	BRAIDED SEED TUBE ESD CABLE
W23	SP5:OUT	---	P3:3	30	16	RED	24V IPN PWR	W47	SP2:OUT	---	P10:1	37	ESD	---	BRAIDED METER ESD CABLE
W24	E1	---	J1:3	22	18	GRN	TRUE DEPTH LINK SENSOR (SHIELD)	W48	SP6:OUT	---	P5:6	25	16	BLK	METER BLDC DRIVER (STRAP)

TRUE RATE PULL ROW UNIT HARNESS (P/N:10915701)

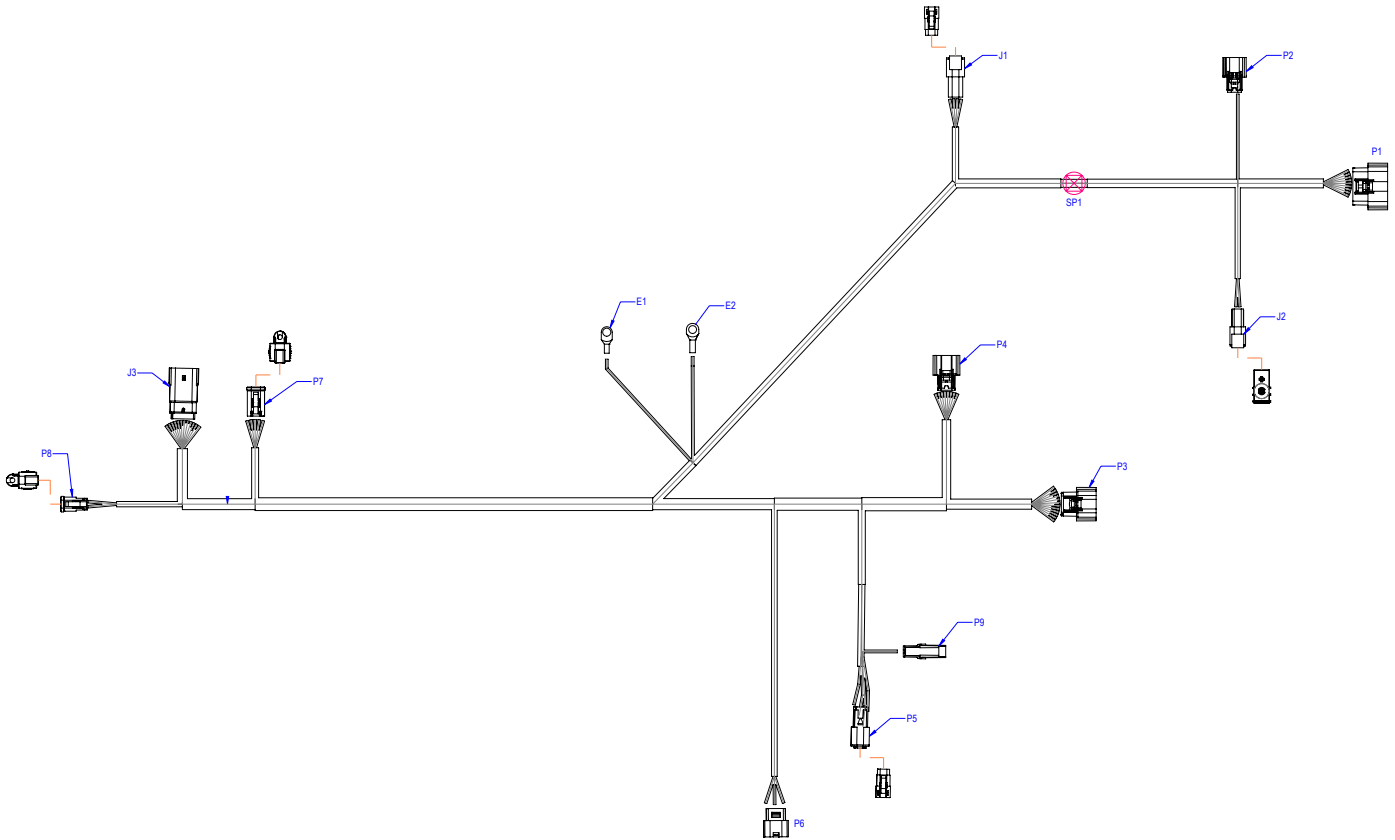

WIRE HOOKUP CHART							
REF DES	FROM	USED W/	TO	USED W/	GAUGE	COLOR	FUNCTION
W1	P1:3	24	P7:5	22	18	RD	FERT ROW CUT OFF VALVE (PWR)
W2	P1:4	24	P7:6	22	18	BK	FERT ROW CUTOFF VALVE (GND)
W3	P1:7	24	P8:1	22	18	VT	TRUE DEPTH CYLINDER PWM+
W4	P1:8	24	P8:2	22	18	BU	TRUE DEPTH CYLINDER PWM-
W5	P4:8	24	P7:3	22	18	VT	FERT FLOW SENSOR (SIGNAL)
W6	J1:2	19	P1:16	24	18	WH	TRUE DEPTH LINK SENSOR (SINGAL)
W7	P1:19	24	SP1:IN	---	18	GY	FERT / TRUE DEPTH SENSOR (GND)
W8	SP1:OUT	---	P7:2	22	18	GY	FERT FLOW SENSOR (GND)
W9	SP1:OUT	---	J1:4	19	18	GY	TRUE DEPTH LINK SENSOR (GND)
W10	J1:1	19	P1:20	24	18	RDWH	TRUE DEPTH LINK SENSOR (PWR)
W11	P2:3	24	P7:1	22	18	RD	FERT FLOW SENSOR (PWR)
W12	J3:1	23	P3:1	26	16	RD	24V IPN PWR
W13	J3:2	23	P3:2	26	16	BK	24V IPN GND
W14	J3:3	23	P3:3	26	16	RD	24V IPN PWR
W15	J3:4	23	P3:4	26	16	BK	24V IPN GND
W16	J3:5	23	P3:5	24	20	YE	IPN STRAPPING
W17	J3:6	23	P3:6	24	20	OG	IPN STRAPPING
W18	J3:7	23	P3:7	24	20	WH	IPN STRAPPING
W19	J3:8	23	P3:8	24	20	GN	IPN STRAPPING
W20	J3:9	23	P3:9	24	20	BU	IPN STRAPPING
W21	J3:10	23	P3:10	24	20	VT	IPN STRAPPING
W22	J3:11	23	P3:11	24	20	GY	IPN STRAPPING (PARITY)
W23	J3:12	23	P3:12	24	20	BN	IPN STRAPPING (GND)
W24	E1	---	J1:3	19	18	GN	TRUE DEPTH LINK SENSOR (SHIELD)
W25	E2	---	P9:1	31	ESD	---	BRAIDED ESD CABLE
W26	J2:2	34	P1:14	24	18	BN	MANUAL RUN (PWR)
W27	J2:1	34	P1:17	24	18	GY	MANUAL RUN (GND)
W28	P4:1	24	P5:1	27	18	RD	SEED METER MOTOR 1+
W29	P4:2	24	P5:2	27	18	WH	SEED METER MOTOR 1-
W30	P4:4	24	P5:3	27	18	GN	SEED METER MOTOR 2+
W31	P4:3	24	P5:4	27	18	BK	SEED METER MOTOR 2-
W32	P4:5	24	P6:1	28	18	RD	SEED SENSOR (PWR)
W33	P4:6	24	P6:6	28	18	BK	SEED SENSOR (GND)
W34	P4:7	24	P6:2	28	18	BU	SEED SENSOR (LIN)

LABEL TABLE			
CONNECTOR	CONNECTOR LABEL	CONNECTOR	CONNECTOR LABEL
P1	RU IPN J7	P5	SEED METER
P2	RU IPN J6	P6	SEED SENSOR
P3	RU IPN J3	P7	FERTILIZER
P4	RU IPN J4	P8	TRUE DEPTH SOLENOID
J1	LINK SENSOR	P9	BRAIDED ESD CABLE
J2	MANUAL RUN	E1	GND
J3	IPN PWR	E2	BRAIDED ESD CABLE
HARNESS LABEL	PART NUMBER REV / DATE VENDOR I.D.		

**TAILLIGHT EXTENSION HARNESS (P/N: A25207)**

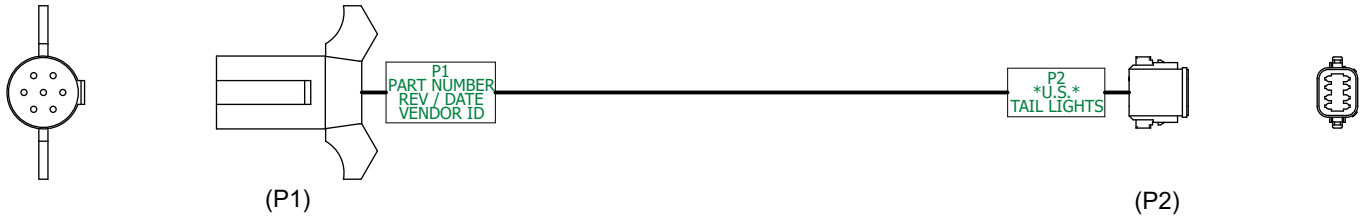

Signal	Wire Gauge	Color	From	To
Ground	16	WHT	P1-1	P2-1
LH Turn	16	YEL	P1-3	P2-3
RH Turn	16	GRN	P1-5	P2-5
Tail	16	BRN	P1-6	P2-6

**TRACTOR CONSOLE HARNESS - 12 ROW, 16 ROW, AND 24 ROW (P/N: A25031)**

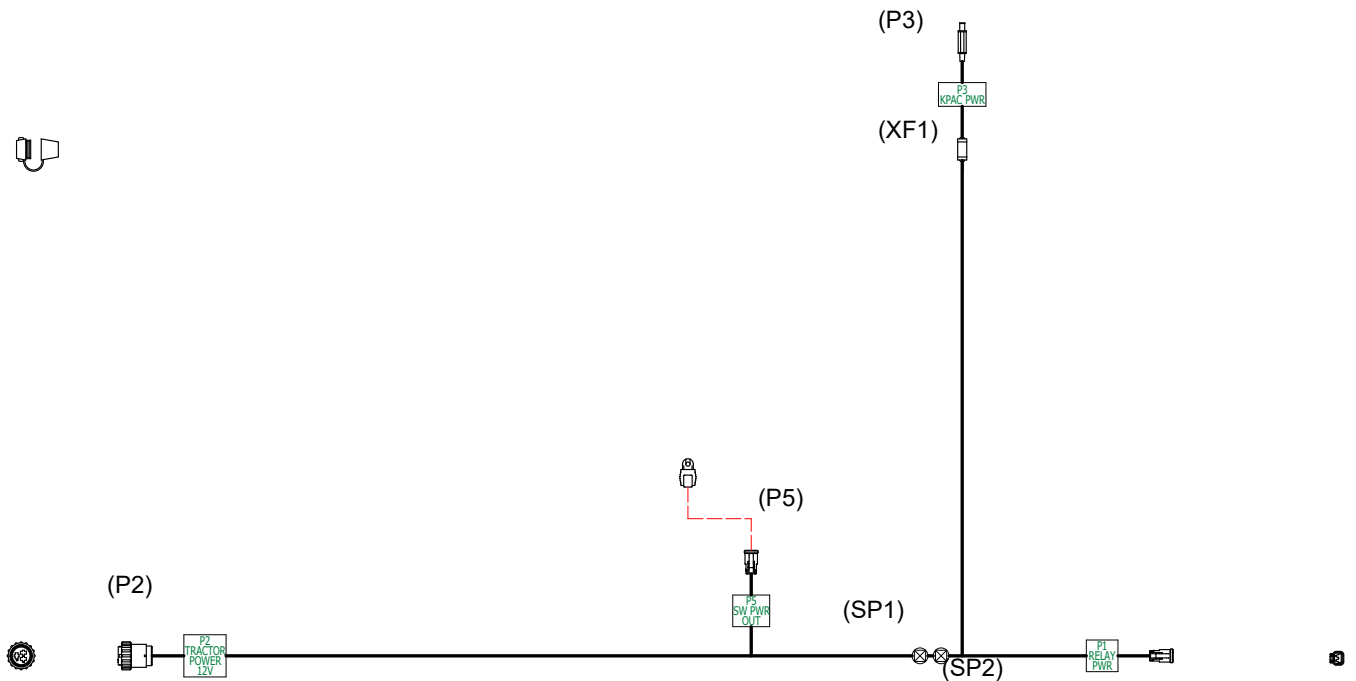

Signal	Wire Gauge	Color	FROM	TO
12V Switched (PWR)	16	RED	P2-1	SP1
Relay (PWR)	18	BLUE	SP1	P1-1
12V Switched (PWR)	18	RED	SP1	XF1-1
12V Switched (PWR)	18	ORN	SP1	P5-1
12V Switched (PWR)	18	RED	XF1-2	P3-1
12V Switched (PWR)	16	BLK	P2-3	SP2
12V Switched (PWR)	18	BLK	SP2	P1-2
12V Switched (PWR)	18	BLK	SP2	P3-2
12V Switched (PWR)	18	BLK	SP2	P5-2

**WORK LIGHT HARNESS (P/N: A22547)**

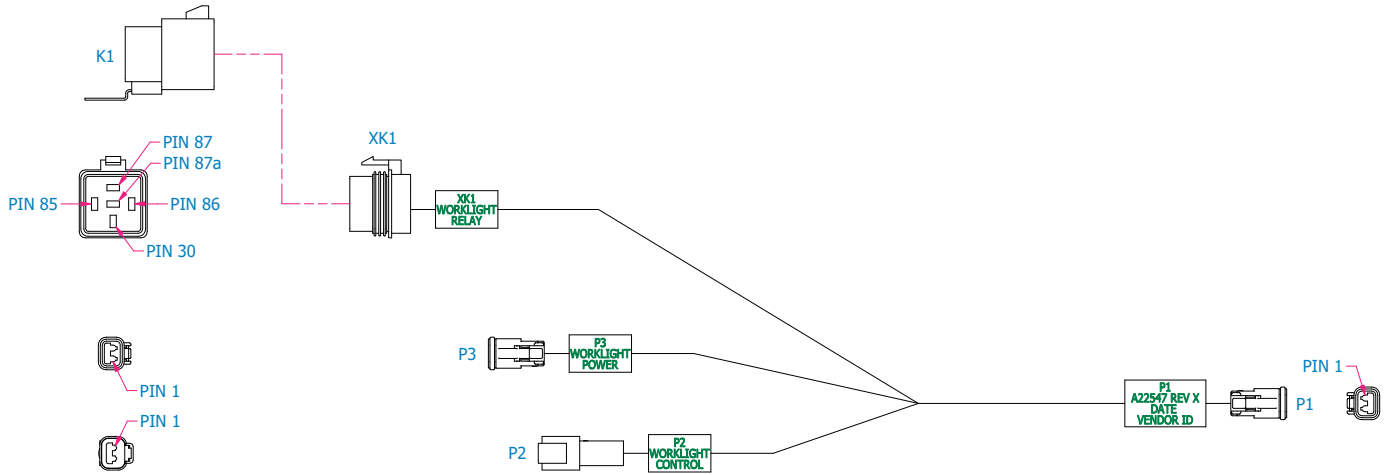

WIRE HOOKUP CHART							
REF DES	FROM	USED WITH ITEM	TO	USED WITH ITEM	GAUGE	COLOR	FUNCTION
W1	P3-1	7	P1-1	7	16	BLK	WORKLIGHT POWER -
W2	P3-2	7	XK1-30	---	16	RED	WORKLIGHT POWER +
W3	P2-1	8	XK1-85	---	16	BLK	RELAY GROUND
W4	P2-2	8	XK1-86	---	16	BLU	RELAY 12V
W5	XK1-87	---	P1-2	7	16	RED	WORKLIGHT POWER +

**INSECTICIDE HARNESS (P/N: A22522)**

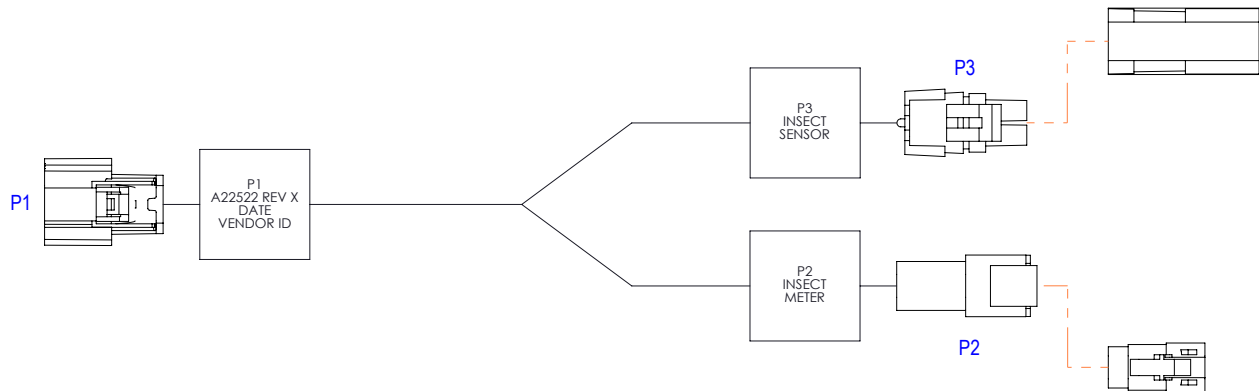

WIRE HOOKUP CHART							
REF DES	FROM	USED W/	TO	USED W/	GAUGE	COLOR	FUNCTION
W1	P1:1	6	P2:1	8	18	RED	INSECTICIDE METER MOTOR 1+
W2	P1:2	6	P2:2	8	18	WHT	INSECTICIDE METER MOTOR 1-
W3	P1:3	6	P2:4	8	18	BLK	INSECTICIDE METER MOTOR 2-
W4	P1:4	6	P2:3	8	18	GRN	INSECTICIDE METER MOTOR 2+
W5	P1:6	6	P3:B	10	18	BLK	INSECTICIDE SENSOR (GND)
W6	P1:7	6	P3:A	10	18	RED	INSECTICIDE SENSOR (PWR/SIGNAL)

**WORK LIGHT HARNESS (P/N: A26346)**

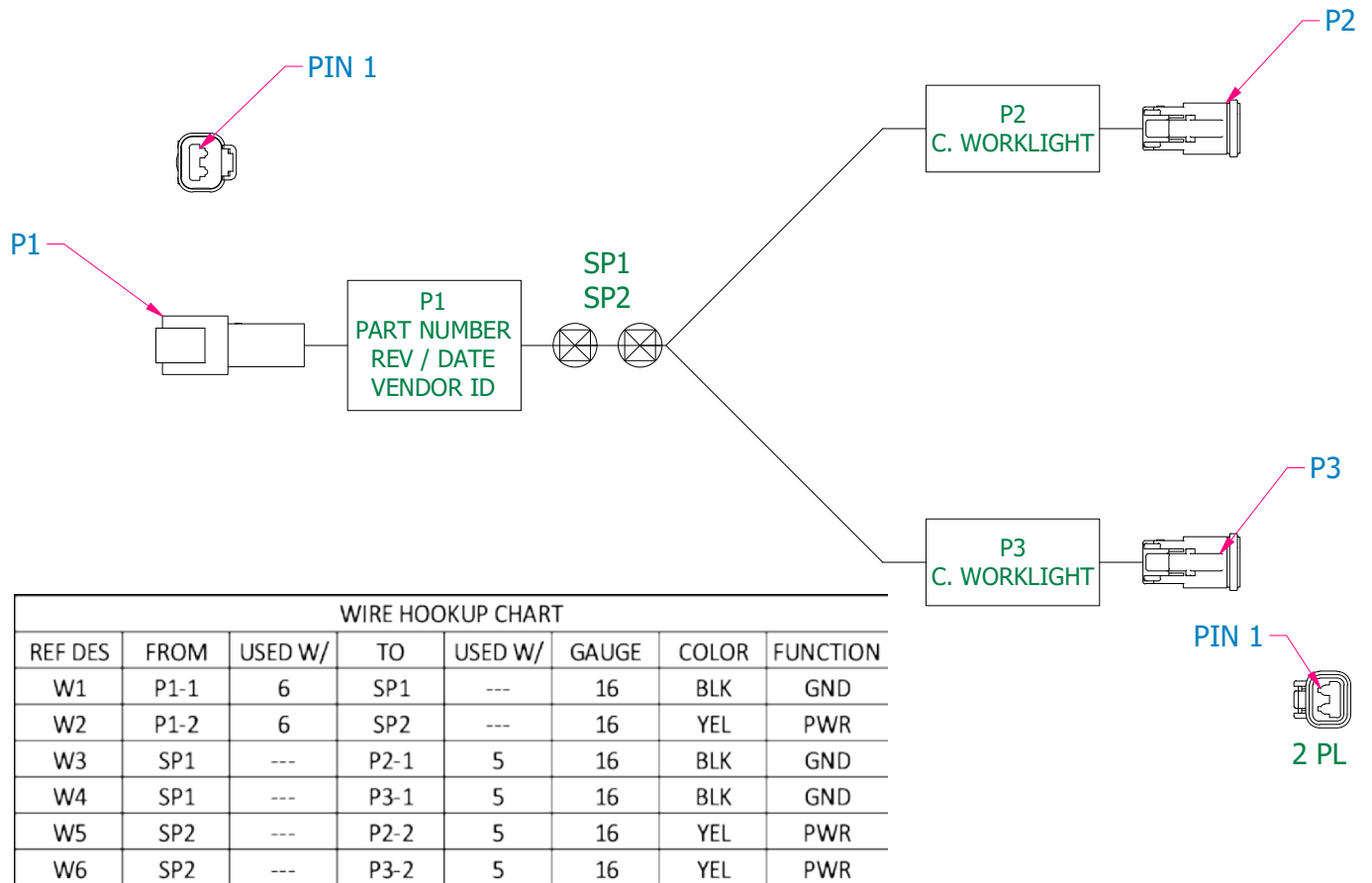

WIRE HOOKUP CHART							
REF DES	FROM	USED W/	TO	USED W/	GAUGE	COLOR	FUNCTION
W1	P1-1	6	SP1	---	16	BLK	GND
W2	P1-2	6	SP2	---	16	YEL	PWR
W3	SP1	---	P2-1	5	16	BLK	GND
W4	SP1	---	P3-1	5	16	BLK	GND
W5	SP2	---	P2-2	5	16	YEL	PWR
W6	SP2	---	P3-2	5	16	YEL	PWR

ROW UNIT POWER HARNESS, 24 ROW 30" - ROWS 1-10 (P/N: 10136601)

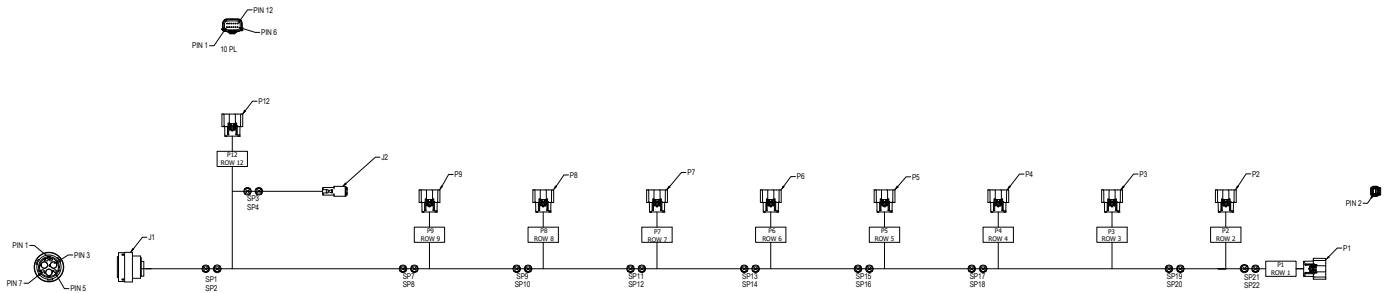

WIRE HOOKUP CHART																							
REF DES	FROM	USED W/	TO	USED W/	GAUGE	COLOR	FUNCTION	REF DES	FROM	USED W/	TO	USED W/	GAUGE	COLOR	FUNCTION	REF DES	FROM	USED W/	TO	USED W/	GAUGE	COLOR	FUNCTION
W1	J1-6	5	SP1	---	4	RED	PWR	W26	SP11	---	P7-1	3	18	RED	RU 7 (PWR)	WS1	SP19	---	P3-3	3	18	RED	RU 3 (PWR)
W2	J1-4	5	SP2	---	4	BLK	GND	W27	SP11	---	P7-3	3	18	RED	RU 7 (PWR)	WS2	SP20	---	SP22	---	14	BLK	GND
W3	SP1	---	SP3	---	14	RED	PWR	W28	SP12	---	SP14	---	8	BLK	GND	WS3	SP20	---	P3-2	3	18	BLK	RU 3 (GND)
W4	SP1	---	SP7	---	6	RED	PWR	W29	SP12	---	P7-2	3	18	BLK	RU 7 (GND)	WS4	SP20	---	P3-4	3	18	BLK	RU 3 (GND)
W5	SP2	---	SP4	---	14	BLK	GND	W30	SP12	---	P7-4	3	18	BLK	RU 7 (GND)	WS5	SP21	---	P2-1	3	18	RED	RU 2 (PWR)
W6	SP2	---	SP8	---	6	BLK	GND	W31	SP13	---	SP15	---	8	RED	PWR	WS6	SP21	---	P2-3	3	18	RED	RU 2 (PWR)
W7	SP3	---	P12-1	3	18	RED	RU 12 (PWR)	W32	SP13	---	P6-1	3	18	RED	RU 6 (PWR)	WS7	SP21	---	P1-1	3	18	RED	RU 1 (PWR)
W8	SP3	---	P12-3	3	18	RED	RU 12 (PWR)	W33	SP13	---	P6-3	3	18	RED	RU 6 (PWR)	WS8	SP21	---	P1-3	3	18	RED	RU 1 (PWR)
W9	SP3	---	J2-1	10	18	RED	PWR	W34	SP14	---	SP16	---	8	BLK	GND	WS9	SP22	---	P2-2	3	18	BLK	RU 2 (GND)
W10	SP4	---	J2-2	10	18	BLK	GND	W35	SP14	---	P6-2	3	18	BLK	RU 6 (GND)	W60	SP22	---	P2-4	3	16	BLK	RU 2 (GND)
W11	SP4	---	P12-2	3	18	BLK	RU 12 (GND)	W36	SP14	---	P6-4	3	18	BLK	RU 6 (GND)	W61	SP22	---	P1-2	3	18	BLK	RU 1 (GND)
W12	SP4	---	P12-4	3	18	BLK	RU 12 (GND)	W37	SP15	---	SP17	---	8	RED	PWR	W62	SP22	---	P1-4	3	16	BLK	RU 1 (GND)
W13	SP7	---	SP9	---	8	RED	PWR	W38	SP15	---	P5-1	3	18	RED	RU 5 (PWR)								
W14	SP7	---	P5-1	3	18	RED	RU 5 (PWR)	W39	SP15	---	P5-3	3	18	RED	RU 5 (PWR)								
W15	SP7	---	P5-3	3	18	RED	RU 5 (PWR)	W40	SP16	---	SP18	---	8	BLK	GND								
W16	SP8	---	SP10	---	8	BLK	GND	W41	SP16	---	P5-2	3	18	BLK	RU 5 (GND)								
W17	SP8	---	P5-2	3	18	BLK	RU 5 (GND)	W42	SP16	---	P5-4	3	16	BLK	RU 5 (GND)								
W18	SP8	---	P5-4	3	18	BLK	RU 5 (GND)	W43	SP17	---	SP19	---	10	RED	PWR								
W19	SP9	---	SP11	---	8	RED	PWR	W44	SP17	---	P4-1	3	18	RED	RU 4 (PWR)								
W20	SP9	---	P6-1	3	16	RED	RU 8 (PWR)	W45	SP17	---	P4-3	3	18	RED	RU 4 (PWR)								
W21	SP9	---	P6-3	3	16	RED	RU 8 (PWR)	W46	SP18	---	SP20	---	10	BLK	GND								
W22	SP10	---	SP12	---	8	BLK	GND	W47	SP18	---	P4-2	3	18	BLK	RU 4 (GND)								
W23	SP10	---	P6-2	3	18	BLK	RU 8 (GND)	W48	SP18	---	P4-4	3	18	BLK	RU 4 (GND)								
W24	SP10	---	P6-4	3	18	BLK	RU 8 (GND)	W49	SP19	---	SP21	---	14	RED	PWR								
W25	SP11	---	SP13	---	8	RED	PWR	W50	SP19	---	P3-1	3	18	RED	RU 3 (PWR)								

STRAPPING TABLE								
CONNECTOR	PIN 5	PIN 6	PIN 7	PIN 8	PIN 9	PIN 10	PIN 11	PIN 12
P1	GND	---	---	---	---	---	---	GND
P2	---	GND	---	---	---	---	---	GND
P3	GND	GND	---	---	---	---	GND	GND
P4	---	---	GND	---	---	---	---	GND
P5	GND	---	GND	---	---	---	GND	GND
P6	---	GND	GND	---	---	---	GND	GND
P7	GND	GND	GND	---	---	---	---	GND
P8	---	---	---	GND	---	---	---	GND
P9	GND	---	---	GND	---	---	GND	GND
P12	---	---	GND	GND	---	---	GND	GND



**ROW UNIT POWER HARNESS, 24 ROW 30" - ROWS 14-24 (P/N: 10136701)**

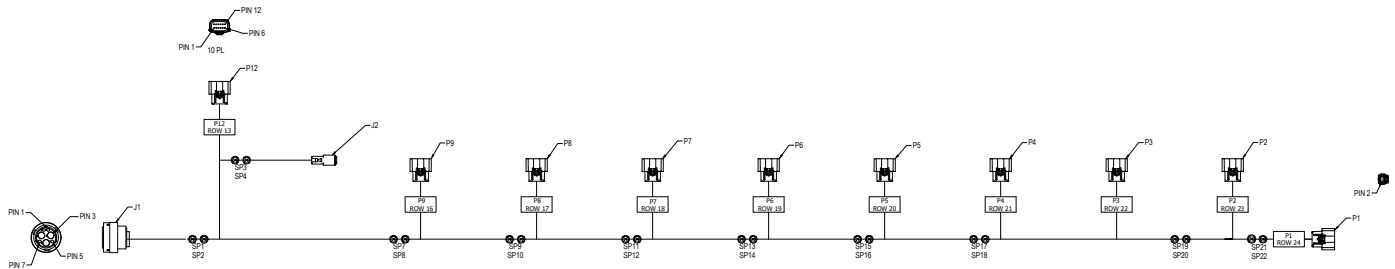

**WIRE HOOKUP CHART**

REF DES	FROM	USED W/	TO	USED W/	GAUGE	COLOR	FUNCTION	REF DES	FROM	USED W/	TO	USED W/	GAUGE	COLOR	FUNCTION	REF DES	FROM	USED W/	TO	USED W/	GAUGE	COLOR	FUNCTION
W1	J1-6	5	SP1	---	4	RED	PWR	W26	SP11	---	P7-1	3	18	RED	RU 18 (PWR)	W51	SP19	---	P3-3	3	18	RED	RU 22 (PWR)
W2	J1-4	5	SP2	---	4	BLK	GND	W27	SP11	---	P7-3	3	18	RED	RU 18 (PWR)	W52	SP20	---	SP22	---	14	BLK	GND
W3	SP1	---	SP3	---	14	RED	PWR	W28	SP12	---	SP14	---	8	BLK	GND	W53	SP20	---	P3-2	3	18	BLK	RU 22 (GND)
W4	SP1	---	SP7	---	6	RED	PWR	W29	SP12	---	P7-2	3	18	BLK	RU 18 (GND)	W54	SP20	---	P3-4	3	18	BLK	RU 22 (GND)
W5	SP2	---	SP4	---	14	BLK	GND	W30	SP12	---	P7-4	3	18	BLK	RU 18 (GND)	W55	SP21	---	P2-1	3	18	RED	RU 23 (PWR)
W6	SP2	---	SP8	---	6	BLK	GND	W31	SP13	---	SP15	---	8	RED	PWR	W56	SP21	---	P2-3	3	18	RED	RU 23 (PWR)
W7	SP3	---	P12-1	3	18	RED	RU 13 (PWR)	W32	SP13	---	P6-1	3	18	RED	RU 19 (PWR)	W57	SP21	---	P1-1	3	18	RED	RU 24 (PWR)
W8	SP3	---	P12-3	3	18	RED	RU 13 (PWR)	W33	SP13	---	P6-3	3	18	RED	RU 19 (PWR)	W58	SP21	---	P1-3	3	18	RED	RU 24 (PWR)
W9	SP3	---	J2-1	10	18	RED	PWR	W34	SP14	---	SP16	---	8	BLK	GND	W59	SP22	---	P2-2	3	18	BLK	RU 23 (GND)
W10	SP4	---	J2-2	10	18	BLK	GND	W35	SP14	---	P6-2	3	18	BLK	RU 19 (GND)	W60	SP22	---	P2-4	3	16	BLK	RU 23 (GND)
W11	SP4	---	P12-2	3	18	BLK	RU 13 (GND)	W36	SP14	---	P6-4	3	18	BLK	RU 19 (GND)	W61	SP22	---	P1-2	3	18	BLK	RU 24 (GND)
W12	SP4	---	P12-4	3	18	BLK	RU 13 (GND)	W37	SP15	---	SP17	---	8	RED	PWR	W62	SP22	---	P1-4	3	16	BLK	RU 24 (GND)
W13	SP7	---	SP9	---	8	RED	PWR	W38	SP15	---	P5-1	3	18	RED	RU 20 (PWR)								
W14	SP7	---	P9-1	3	18	RED	RU 16 (PWR)	W39	SP15	---	P5-3	3	18	RED	RU 20 (PWR)								
W15	SP7	---	P9-3	3	18	RED	RU 16 (PWR)	W40	SP16	---	SP18	---	8	BLK	GND								
W16	SP8	---	SP10	---	8	BLK	GND	W41	SP16	---	P5-2	3	18	BLK	RU 20 (GND)								
W17	SP8	---	P9-2	3	18	BLK	RU 16 (GND)	W42	SP16	---	P5-4	3	16	BLK	RU 20 (GND)								
W18	SP8	---	P9-4	3	18	BLK	RU 16 (GND)	W43	SP17	---	SP19	---	10	RED	PWR								
W19	SP9	---	SP11	---	8	RED	PWR	W44	SP17	---	P4-1	3	18	RED	RU 21 (PWR)								
W20	SP9	---	P8-1	3	16	RED	RU 17 (PWR)	W45	SP17	---	P4-3	3	18	RED	RU 21 (PWR)								
W21	SP9	---	P8-3	3	16	RED	RU 17 (PWR)	W46	SP18	---	SP20	---	10	BLK	GND								
W22	SP10	---	SP12	---	8	BLK	GND	W47	SP18	---	P4-2	3	18	BLK	RU 21 (GND)								
W23	SP10	---	P8-2	3	18	BLK	RU 17 (GND)	W48	SP18	---	P4-4	3	18	BLK	RU 21 (GND)								
W24	SP10	---	P8-4	3	18	BLK	RU 17 (GND)	W49	SP19	---	SP21	---	14	RED	PWR								
W25	SP11	---	SP13	---	8	RED	PWR	W50	SP19	---	P3-1	3	18	RED	RU 22 (PWR)								

**STRAPPING TABLE**

CONNECTOR	PIN 5	PIN 6	PIN 7	PIN 8	PIN 9	PIN 10	PIN 11	PIN 12
P1	---	---	---	GND	GND	---	GND	GND
P2	GND	GND	GND	---	GND	---	GND	GND
P3	---	GND	GND	---	GND	---	---	GND
P4	GND	---	GND	---	GND	---	---	GND
P5	---	---	GND	---	GND	---	GND	GND
P6	GND	GND	---	---	GND	---	---	GND
P7	---	GND	---	---	GND	---	GND	GND
P8	GND	---	---	---	GND	---	GND	GND
P9	---	---	---	---	GND	---	---	GND
P12	GND	---	GND	GND	---	---	---	GND

24V POWER HARNESS - 24 ROW 30" (P/N: 10136801)

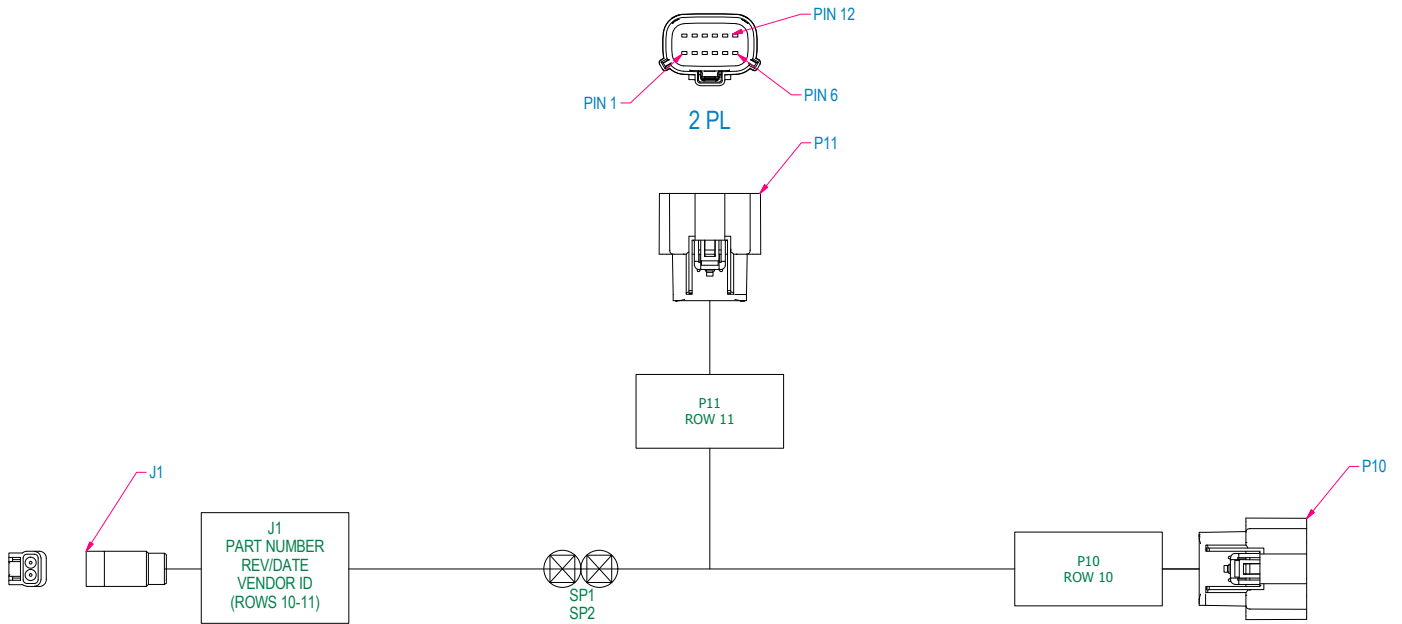

WIRE HOOKUP CHART							
REF DES	FROM	USED W/	TO	USED W/	GAUGE	COLOR	FUNCTION
W1	J1-1	6	SP1	---	16	RED	PWR
W2	J1-2	6	SP2	---	16	BLK	GND
W7	SP1	---	P11-1	2	18	RED	RU 15 (PWR)
W8	SP1	---	P11-3	2	18	RED	RU 15 (PWR)
W9	SP2	---	P11-2	2	18	BLK	RU 15 (GND)
W10	SP2	---	P11-4	2	18	BLK	RU 15 (GND)
W11	SP1	---	P10-1	2	18	RED	RU 14 (PWR)
W12	SP1	---	P10-3	2	18	RED	RU 14 (PWR)
W13	SP2	---	P10-2	2	18	BLK	RU 14 (GND)
W14	SP2	---	P10-4	2	18	BLK	RU 14 (GND)

STRAPPING TABLE								
CONNECTOR	PIN 5	PIN 6	PIN 7	PIN 8	PIN 9	PIN 10	PIN 11	PIN 12
P10	---	GND	---	GND	---	---	GND	GND
P11	GND	GND	---	GND	---	---	---	GND

ROW UNIT POWER HARNESS, 24 ROW 20" - ROWS 1-12 (P/N: A26572)

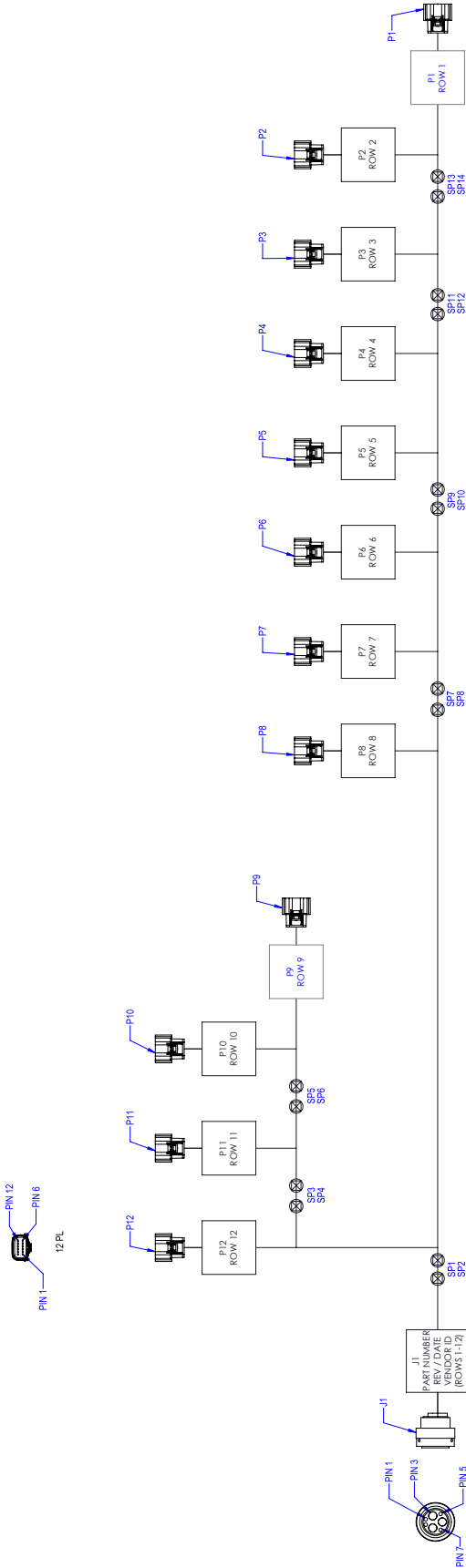

WIRE HOOKUP CHART

REF DES	FROM	TO	USED W/	CALICE	FUNCTION	REF DES	FROM	USED W/	TO	USED W/	CALICE	COLOR	FUNCTION
W1	J1-6	SP1	---	4	RED	W32	SP8	---	P8-4	---	18	BLK	RU8(GND)
W2	J1-4	SP2	---	4	RED	W33	SP8	---	P7-2	---	18	BLK	RU7(GND)
W3	SP1	SP3	---	16	RED	W34	SP8	---	P7-4	---	18	BLK	RU7(GND)
W4	SP1	SP7	---	8	RED	W35	SP9	---	SP11	---	10	RED	PWR
W5	SP2	SP4	---	16	BLK	W36	SP9	---	P6-1	---	18	RED	RU6(PWR)
W6	SP2	SP8	---	8	BLK	W37	SP9	---	P6-3	---	18	RED	RU6(PWR)
W7	SP3	SP5	---	16	RED	W38	SP9	---	P5-1	---	18	RED	RU5(PWR)
W8	SP3	SP9	---	16	RED	W39	SP9	---	P5-3	---	18	RED	RU5(PWR)
W9	SP3	P12-3	---	3	RED	W40	SP10	---	SP12	---	10	BLK	GND
W10	SP3	P11-1	---	3	RED	W41	SP10	---	P6-2	---	18	BLK	RU6(GND)
W11	SP3	P11-3	---	3	RED	W42	SP10	---	P6-4	---	18	BLK	RU6(GND)
W12	SP4	SP6	---	16	BLK	W43	SP10	---	P6-2	---	18	BLK	RU5(GND)
W13	SP4	P12-2	---	3	BLK	W44	SP10	---	P5-4	---	18	BLK	RU5(GND)
W14	SP4	P12-4	---	3	BLK	W45	SP11	---	SP13	---	14	RED	PWR
W15	SP4	P11-2	---	3	BLK	W46	SP11	---	P4-1	---	3	BLK	RU4(PWR)
W16	SP4	P11-4	---	3	BLK	W47	SP11	---	P4-3	---	3	BLK	RU4(PWR)
W17	SP5	P10-1	---	3	RED	W48	SP11	---	SP1	---	3	BLK	RU3(PWR)
W18	SP5	P10-3	---	3	RED	W49	SP11	---	P3-3	---	3	BLK	RU3(PWR)
W19	SP5	P9-1	---	3	RED	W50	SP12	---	SP14	---	14	BLK	GND
W20	SP5	P10-2	---	3	RED	W51	SP12	---	P4-2	---	3	BLK	RU4(GND)
W21	SP6	P10-4	---	3	RED	W52	SP12	---	P4-4	---	3	BLK	RU4(GND)
W22	SP6	P10-4	---	3	RED	W53	SP12	---	P3-2	---	3	BLK	RU3(GND)
W23	SP6	P9-2	---	3	RED	W54	SP12	---	P3-4	---	3	BLK	RU3(GND)
W24	SP6	P9-4	---	3	RED	W55	SP13	---	P3-1	---	3	BLK	RU2(PWR)
W25	SP7	SP9	---	10	RED	W56	SP13	---	P2-3	---	3	BLK	RU2(PWR)
W26	SP7	SP9	---	10	RED	W57	SP13	---	P2-1	---	3	BLK	RU2(PWR)
W27	SP7	P8-1	---	3	RED	W58	SP13	---	P1-1	---	3	RED	RU1(PWR)
W28	SP7	P8-3	---	3	RED	W59	SP14	---	P1-3	---	3	RED	RU1(PWR)
W29	SP7	P7-1	---	3	RED	W60	SP14	---	P2-2	---	3	BLK	RU2(GND)
W30	SP8	SP10	---	20	BLK	W61	SP14	---	P1-2	---	3	BLK	RU2(GND)
W31	SP8	P8-2	---	3	BLK	W62	SP14	---	P1-4	---	3	BLK	RU1(GND)

STRAPPING TABLE

CONNECTOR	PIN 5	PIN 6	PIN 7	PIN 8	PIN 9	PIN 10	PIN 11	PIN 12	ROW#
P1	GND	---	---	---	---	---	---	GND	1
P2	GND	GND	---	---	---	---	---	GND	2
P3	GND	GND	---	---	---	---	---	GND	3
P4	---	---	GND	---	---	---	---	GND	4
P5	GND	---	GND	---	---	---	---	GND	5
P6	---	GND	GND	---	---	---	---	GND	6
P7	GND	GND	GND	---	---	---	---	GND	7
P8	---	---	---	GND	---	---	---	GND	8
P9	GND	---	---	GND	---	---	---	GND	9
P10	---	---	GND	---	---	---	---	GND	10
P11	GND	GND	GND	---	---	---	---	GND	11
P12	---	---	---	GND	---	---	---	GND	12

ROW UNIT POWER HARNESS, 24 ROW 20" - ROWS 13-24 (P/N: A26571)

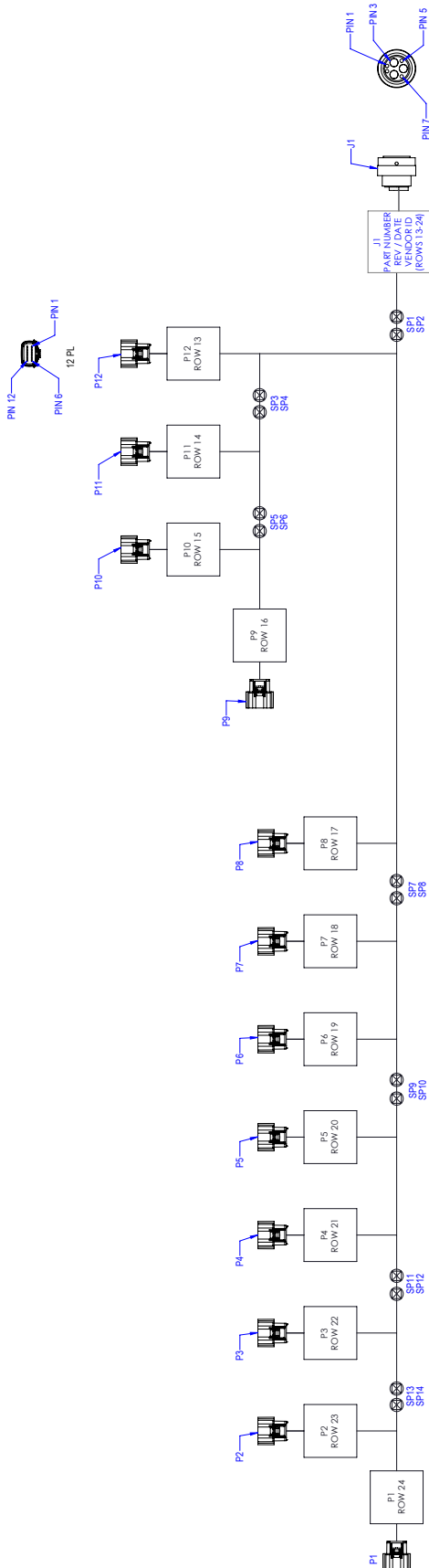

WIRE HOOKUP CHART

REFS	FROM	USED W/	TO	USED W/	GAUGE	COLOR	FUNCTION	REFS	RELAYS	TO	USED W/	GAUGE	COLOR	FUNCTION
W1	J1.6	5	SP1	---	4	RED	RELAY	W2	SP8	P4.4	3	18	BLK	RU.1(GND)
W2	J1.4	5	SP2	---	4	BLK	RELAY	W3	SP8	P7.2	3	18	BLK	RU.7(GND)
W3	SP1	---	SP3	---	16	RED	RELAY	W4	SP8	P7.4	3	18	BLK	RU.7(GND)
W4	SP1	---	SP4	---	8	RED	RELAY	W5	SP9	---	---	---	---	---
W5	SP2	---	SP4	---	8	BLK	RELAY	W6	SP9	---	---	---	---	---
W6	SP2	---	SP8	---	8	BLK	RELAY	W7	SP9	---	---	---	---	---
W7	SP3	---	SP8	---	16	RED	RELAY	W8	SP9	---	---	---	---	---
W8	SP3	---	P1.21	---	3	18	RED	W9	SP9	---	---	---	---	---
W9	SP3	---	P1.23	---	3	18	RED	W10	SP10	---	---	---	---	---
W10	SP3	---	P1.14	---	3	18	RED	W11	SP10	---	---	---	---	---
W11	SP3	---	P1.13	---	3	18	RED	W12	SP10	---	---	---	---	---
W12	SP4	---	SP8	---	16	BLK	RELAY	W13	SP10	---	---	---	---	---
W13	SP4	---	P1.22	---	3	18	BLK	W14	SP10	---	---	---	---	---
W14	SP4	---	P1.24	---	3	18	BLK	W15	SP11	---	---	---	---	---
W15	SP4	---	P1.12	---	3	18	BLK	W16	SP11	---	---	---	---	---
W16	SP4	---	P1.14	---	3	18	BLK	W17	SP11	---	---	---	---	---
W17	SP5	---	P1.03	---	3	18	RED	W18	SP11	---	---	---	---	---
W18	SP5	---	P1.03	---	3	18	RED	W19	SP11	---	---	---	---	---
W19	SP5	---	SP4	---	3	18	RED	W20	SP12	---	---	---	---	---
W20	SP5	---	SP2	---	3	18	RED	W21	SP12	---	---	---	---	---
W21	SP6	---	P1.02	---	3	18	BLK	W22	SP12	---	---	---	---	---
W22	SP6	---	P1.04	---	3	18	BLK	W23	SP12	---	---	---	---	---
W23	SP6	---	SP2	---	3	18	BLK	W24	SP12	---	---	---	---	---
W24	SP6	---	SP4	---	3	18	BLK	W25	SP13	---	---	---	---	---
W25	SP7	---	SP9	---	10	RED	RELAY	W26	SP13	---	---	---	---	---
W26	SP7	---	SP8	---	10	RED	RELAY	W27	SP13	---	---	---	---	---
W27	SP7	---	SP3	---	3	18	RED	W28	SP13	---	---	---	---	---
W28	SP7	---	SP1	---	3	18	RED	W29	SP14	---	---	---	---	---
W29	SP7	---	SP3	---	3	18	RED	W30	SP14	---	---	---	---	---
W30	SP8	---	SP10	---	10	BLK	RELAY	W31	SP14	---	---	---	---	---
W31	SP8	---	SP2	---	3	18	BLK	W32	SP14	---	---	---	---	---

STRAPPING TABLE											
CONNECTOR	PN5	PN6	PN7	PN8	PN9	PN10	PN11	PN12	ROW #		
P1	GND	GND	GND	GND	GND	GND	GND	GND	24		
P2	GND	GND	GND	GND	GND	GND	GND	GND	23		
P3	GND	GND	GND	GND	GND	GND	GND	GND	22		
P4	GND	GND	GND	GND	GND	GND	GND	GND	21		
P5	GND	GND	GND	GND	GND	GND	GND	GND	20		
P6	GND	GND	GND	GND	GND	GND	GND	GND	19		
P7	GND	GND	GND	GND	GND	GND	GND	GND	18		
P8	GND	GND	GND	GND	GND	GND	GND	GND	17		
P9	GND	GND	GND	GND	GND	GND	GND	GND	16		
P10	GND	GND	GND	GND	GND	GND	GND	GND	15		
P11	GND	GND	GND	GND	GND	GND	GND	GND	14		
P12	GND	GND	GND	GND	GND	GND	GND	GND	13		

## ROW UNIT POWER HARNESS, 36 ROW - ROWS 1-13, 17, AND 18 (P/N: 10132001)

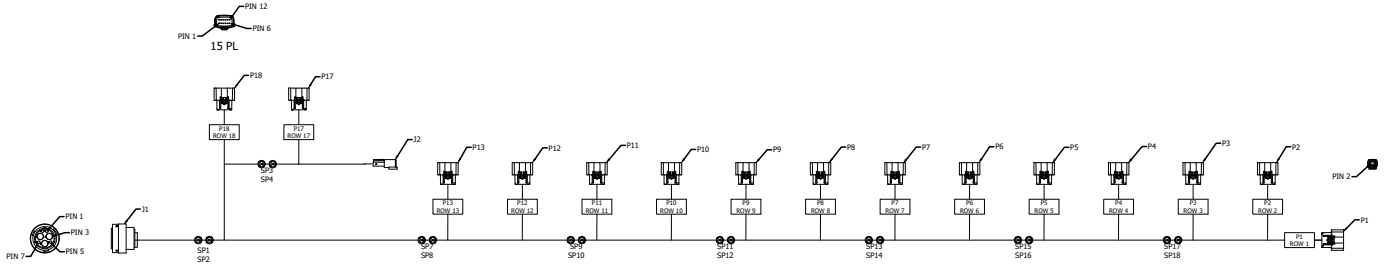

WIRE HOOKUP CHART														STRAPPING TABLE												
REF DES	FROM	USED W/	TO	USED W/	GAUGE	COLOR	FUNCTION	REF DES	FROM	USED W/	TO	USED W/	GAUGE	COLOR	FUNCTION	CONNECTOR	PIN 5	PIN 6	PIN 7	PIN 8	PIN 9	PIN 10	PIN 11	PIN 12		
W1	J1-6	5	SP1	---	4	RED	PWR	W40	SP11	---	P8-1	3	18	RED	P8 (PWR)	P1	GND	---	---	---	---	---	---	---	GND	
W2	J1-4	5	SP2	---	4	BLK	GND	W41	SP11	---	P8-3	3	18	RED	P8 (PWR)	P2	---	GND	---	---	---	---	---	---	---	GND
W3	SP3	---	SP3	---	14	RED	PWR	W42	SP12	---	SP14	---	6	BLK	GND	P3	GND	GND	---	---	---	---	---	---	---	GND
W4	SP1	---	P18-1	3	18	RED	RU 18 (PWR)	W43	SP12	---	P9-2	3	18	BLK	P5 (GND)	P4	GND	GND	---	---	---	---	---	---	---	GND
W5	SP1	---	P18-3	3	18	RED	RU 18 (PWR)	W44	SP12	---	P9-4	3	18	BLK	P5 (GND)	P5	GND	GND	---	---	---	---	---	---	---	GND
W6	SP1	---	SP7	---	6	RED	PWR	W45	SP12	---	P8-2	3	18	BLK	P6 (GND)	P6	---	GND	---	---	---	---	---	---	---	GND
W7	SP2	---	SP4	---	14	BLK	GND	W46	SP12	---	P8-4	3	18	BLK	P6 (GND)	P5	GND	---	GND	---	---	---	---	---	---	GND
W8	SP2	---	P18-2	3	18	BLK	RU 18 (GND)	W47	SP13	---	SP15	---	8	RED	PWR	P6	---	GND	---	---	---	---	---	---	---	GND
W9	SP2	---	P18-4	3	18	BLK	RU 18 (GND)	W48	SP13	---	P7-1	3	18	RED	P7 (PWR)	P7	GND	GND	---	---	---	---	---	---	---	GND
W10	SP2	---	SP8	---	6	BLK	GND	W49	SP13	---	P7-3	3	18	RED	P7 (PWR)	P8	---	---	---	---	---	---	---	---	---	GND
W11	SP3	---	P17-1	3	18	RED	RU 17 (PWR)	W50	SP13	---	P6-1	3	18	RED	P6 (PWR)	P9	GND	---	GND	---	---	---	---	---	---	GND
W12	SP3	---	P17-3	3	18	RED	RU 17 (PWR)	W51	SP13	---	P6-3	3	18	RED	P6 (PWR)	P10	GND	---	GND	---	---	---	---	---	---	GND
W13	SP3	---	J2-1	10	16	RED	PWR	W52	SP14	---	SP16	---	8	BLK	GND	P11	---	GND	---	GND	---	---	---	---	---	GND
W14	SP4	---	P17-2	3	18	BLK	RU 17 (GND)	W53	SP14	---	P7-2	3	18	BLK	P7 (GND)	P12	GND	GND	---	GND	---	---	---	---	---	GND
W15	SP4	---	P17-4	3	18	BLK	RU 17 (GND)	W54	SP14	---	P7-4	3	18	BLK	P7 (GND)	P13	---	---	GND	---	---	---	---	---	---	GND
W16	SP4	---	J2-2	10	16	BLK	GND	W55	SP14	---	P6-2	3	18	BLK	P6 (GND)	P14	---	---	GND	---	---	---	---	---	---	GND
W17	SP7	---	SP9	---	6	RED	PWR	W56	SP14	---	P6-4	3	18	BLK	P6 (GND)	P15	GND	---	GND	---	---	---	---	---	---	GND
W18	SP7	---	P13-1	3	18	RED	RU 13 (PWR)	W57	SP15	---	SP17	---	10	RED	PWR	P16	GND	---	---	---	---	---	---	---	---	GND
W19	SP7	---	P13-3	3	18	RED	RU 13 (PWR)	W58	SP15	---	SP-1	3	18	RED	P5 (PWR)	P17	GND	---	GND	---	---	---	---	---	---	GND
W20	SP7	---	P13-1	3	18	RED	RU 12 (PWR)	W59	SP15	---	P5-3	3	18	RED	P5 (PWR)	P18	---	GND	---	---	GND	---	---	---	---	GND
W21	SP7	---	P12-3	3	18	RED	RU 12 (PWR)	W60	SP15	---	P4-1	3	18	RED	P4 (PWR)											
W22	SP8	---	SP10	---	6	BLK	GND	W61	SP15	---	P4-3	3	18	RED	P4 (PWR)											
W23	SP8	---	P13-2	3	18	BLK	RU 13 (GND)	W62	SP16	---	SP18	---	10	BLK	GND											
W24	SP8	---	P13-4	3	18	BLK	RU 13 (GND)	W63	SP16	---	P5-2	3	18	BLK	P5 (GND)											
W25	SP8	---	P12-2	3	18	BLK	RU 12 (GND)	W64	SP16	---	P5-4	3	18	BLK	P5 (GND)											
W26	SP8	---	P12-4	3	18	BLK	RU 12 (GND)	W65	SP16	---	P6-2	3	18	BLK	P4 (GND)											
W27	SP9	---	SP11	---	6	RED	PWR	W66	SP16	---	P4-4	3	18	BLK	P4 (GND)											
W28	SP9	---	P11-1	3	18	RED	P11 (PWR)	W67	SP17	---	P3-1	3	18	RED	P3 (PWR)											
W29	SP9	---	P11-3	3	18	RED	P11 (PWR)	W68	SP17	---	P3-3	3	18	RED	P3 (PWR)											
W30	SP9	---	P10-1	3	18	RED	P10 (PWR)	W69	SP17	---	P2-1	3	18	RED	P2 (PWR)											
W31	SP9	---	P10-3	3	18	RED	P10 (PWR)	W70	SP17	---	P2-3	3	18	RED	P2 (PWR)											
W32	SP10	---	SP12	---	6	BLK	GND	W71	SP17	---	P1-1	3	18	RED	P1 (PWR)											
W33	SP10	---	P11-2	3	18	BLK	P11 (GND)	W72	SP17	---	P1-3	3	18	RED	P1 (PWR)											
W34	SP10	---	P11-4	3	18	BLK	P11 (GND)	W73	SP18	---	P3-2	3	18	BLK	P3 (GND)											
W35	SP10	---	P10-2	3	18	BLK	P10 (GND)	W74	SP18	---	P3-4	3	18	BLK	P3 (GND)											
W36	SP10	---	P10-4	3	18	BLK	P10 (GND)	W75	SP18	---	P2-2	3	18	BLK	P2 (GND)											
W37	SP11	---	SP13	---	6	RED	PWR	W76	SP18	---	P2-4	3	18	BLK	P2 (GND)											
W38	SP11	---	P9-1	3	18	RED	P9 (PWR)	W77	SP18	---	P1-2	3	18	BLK	P1 (GND)											
W39	SP11	---	P9-3	3	18	RED	P9 (PWR)	W78	SP18	---	P1-4	3	18	BLK	P1 (GND)											

ROW UNIT POWER HARNESS, 36 ROW - ROWS 19, 20, AND 24-36 (P/N: 10132201)

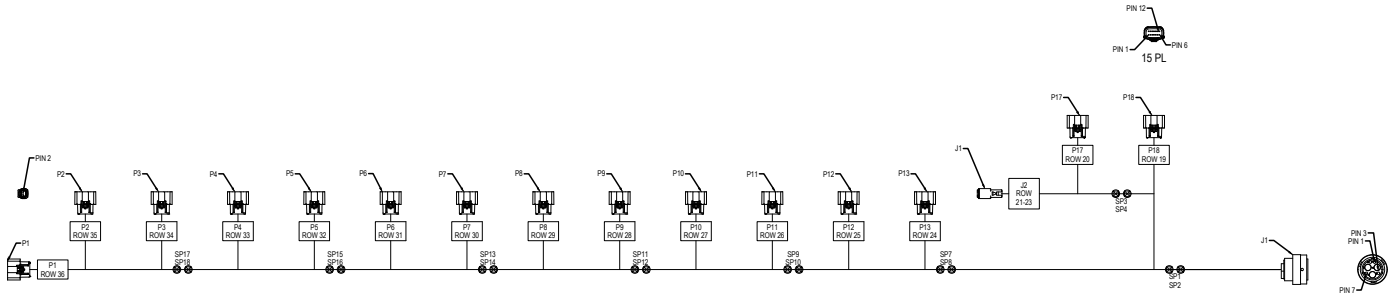

WIRE HOOKUP CHART															
REF. DES.	FROM	USED W/	TO	USED W/	GAUGE	COLOR	FUNCTION	REF. DES.	FROM	USED W/	TO	USED W/	GAUGE	COLOR	FUNCTION
W1	J1-6	5	SP1	---	4	RED	PWR	W44	SP11	---	P8-1	3	18	RED	RU 29 (PWR)
W2	J1-6	5	SP2	---	4	BLK	GND	W45	SP11	---	P8-3	3	18	RED	RU 29 (PWR)
W3	SP1	---	SP3	---	14	RED	PWR	W46	SP12	---	SP14	---	6	BLK	GND
W4	SP1	---	SP7	---	6	RED	PWR	W47	SP12	---	P8-2	3	18	BLK	RU 28 (GND)
W5	SP1	---	P18-1	3	18	RED	RU 19 (PWR)	W48	SP12	---	P8-4	3	18	BLK	RU 28 (GND)
W6	SP1	---	P18-3	3	18	RED	RU 19 (PWR)	W49	SP12	---	P8-2	3	18	BLK	RU 29 (GND)
W7	SP2	---	SP4	---	14	BLK	GND	W50	SP12	---	P8-4	3	18	BLK	RU 29 (GND)
W8	SP2	---	SP8	---	6	BLK	GND	W51	SP13	---	SP15	---	8	RED	PWR
W9	SP2	---	P18-2	3	18	BLK	RU 19 (GND)	W52	SP13	---	P7-1	3	18	RED	RU 30 (PWR)
W10	SP2	---	P18-4	3	18	BLK	RU 19 (GND)	W53	SP13	---	P7-3	3	18	RED	RU 30 (PWR)
W11	SP3	---	J2-1	10	18	RED	PWR	W54	SP13	---	P6-1	3	18	RED	RU 31 (PWR)
W12	SP3	---	P12-1	3	18	RED	RU 20 (PWR)	W55	SP13	---	P6-3	3	18	RED	RU 31 (PWR)
W13	SP3	---	P12-3	3	18	RED	RU 20 (PWR)	W56	SP14	---	SP16	---	8	BLK	GND
W14	SP4	---	J2-2	10	16	BLK	GND	W57	SP14	---	P7-2	3	18	BLK	RU 30 (GND)
W15	SP4	---	P12-2	3	18	BLK	RU 20 (GND)	W58	SP14	---	P7-4	3	18	BLK	RU 30 (GND)
W16	SP4	---	P12-4	3	18	BLK	RU 20 (GND)	W59	SP14	---	P6-2	3	18	BLK	RU 31 (GND)
W17	SP7	---	SP9	---	6	RED	PWR	W60	SP14	---	P6-4	3	18	BLK	RU 31 (GND)
W18	SP7	---	P13-1	3	18	RED	RU 24 (PWR)	W61	SP15	---	SP17	---	8	RED	PWR
W19	SP7	---	P13-3	3	18	RED	RU 24 (PWR)	W62	SP15	---	P5-1	3	18	RED	RU 32 (PWR)
W20	SP7	---	P12-1	3	18	RED	RU 25 (PWR)	W63	SP15	---	P5-3	3	18	RED	RU 32 (PWR)
W21	SP7	---	P12-3	3	18	RED	RU 25 (PWR)	W64	SP15	---	P4-1	3	18	RED	RU 33 (PWR)
W22	SP8	---	SP10	---	6	BLK	GND	W65	SP15	---	P4-3	3	18	RED	RU 33 (PWR)
W23	SP8	---	P13-2	3	18	BLK	RU 24 (GND)	W66	SP16	---	SP18	---	10	BLK	GND
W24	SP8	---	P13-4	3	18	BLK	RU 24 (GND)	W67	SP16	---	P5-2	3	18	BLK	RU 32 (GND)
W25	SP8	---	P12-2	3	18	BLK	RU 25 (GND)	W68	SP16	---	P5-4	3	18	BLK	RU 33 (GND)
W26	SP8	---	P12-4	3	18	BLK	RU 25 (GND)	W69	SP16	---	P4-2	3	18	BLK	RU 33 (GND)
W27	SP9	---	SP11	---	6	RED	PWR	W70	SP16	---	P4-4	3	18	BLK	RU 33 (GND)
W28	SP9	---	P11-1	3	18	RED	RU 26 (PWR)	W71	SP17	---	P3-1	3	18	RED	RU 34 (PWR)
W29	SP9	---	P11-3	3	18	RED	RU 26 (PWR)	W72	SP17	---	P3-3	3	18	RED	RU 34 (PWR)
W30	SP9	---	P10-1	3	18	RED	RU 27 (PWR)	W73	SP17	---	P2-1	3	18	RED	RU 35 (PWR)
W31	SP9	---	P10-3	3	18	RED	RU 27 (PWR)	W74	SP17	---	P2-3	3	18	RED	RU 35 (PWR)
W32	SP10	---	SP12	---	6	BLK	GND	W75	SP17	---	P1-1	3	18	RED	RU 36 (PWR)
W33	SP10	---	P11-2	3	18	BLK	RU 26 (GND)	W76	SP17	---	P1-3	3	18	RED	RU 36 (PWR)
W34	SP10	---	P11-4	3	18	BLK	RU 26 (GND)	W77	SP18	---	P3-2	3	18	BLK	RU 34 (GND)
W35	SP10	---	P10-2	3	18	BLK	RU 27 (GND)	W78	SP18	---	P3-4	3	18	BLK	RU 34 (GND)
W36	SP10	---	P10-4	3	18	BLK	RU 27 (GND)	W79	SP18	---	P2-2	3	18	BLK	RU 35 (GND)
W37	SP11	---	SP13	---	6	RED	PWR	W80	SP18	---	P2-4	3	18	BLK	RU 35 (GND)
W38	SP11	---	P9-1	3	18	RED	RU 28 (PWR)	W81	SP18	---	P1-2	3	18	BLK	RU 36 (GND)
W39	SP11	---	P9-3	3	18	RED	RU 28 (PWR)	W82	SP18	---	P1-4	3	18	BLK	RU 36 (GND)

STRAPPING TABLE								
CONNECTOR	PIN 5	PIN 6	PIN 7	PIN 8	PIN 9	PIN 10	PIN 11	PIN 12
P1	---	---	GND	---	---	GND	GND	GND
P2	GND	GND	---	---	---	GND	---	GND
P3	---	---	---	---	---	GND	GND	GND
P4	GND	---	---	---	---	GND	GND	GND
P5	---	---	---	---	---	GND	GND	GND
P6	GND	GND	GND	GND	GND	---	---	GND
P7	---	GND	GND	GND	GND	---	---	GND
P8	GND	---	GND	GND	GND	---	---	GND
P9	---	---	GND	GND	GND	---	---	GND
P10	GND	GND	---	GND	GND	---	---	GND
P11	---	GND	---	GND	GND	---	---	GND
P12	GND	---	---	GND	GND	---	---	GND
P13	---	---	---	GND	GND	---	---	GND
P17	---	GND	---	GND	GND	---	---	GND
P18	GND	GND	---	GND	GND	---	---	GND

**24V POWER HARNESS - 24 ROW (P/N: 10136901)**

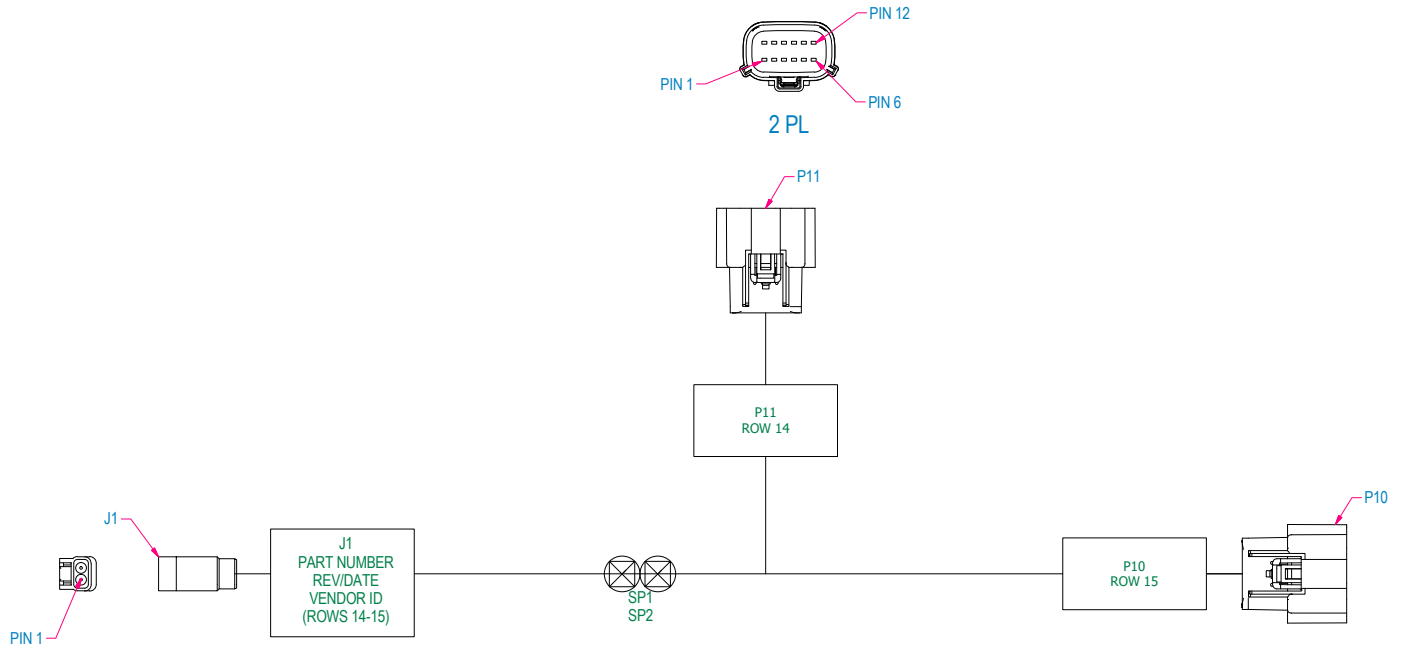

WIRE HOOKUP CHART

REF DES	FROM	USED W/	TO	USED W/	GAUGE	COLOR	FUNCTION
W1	J1-1	6	SP1	---	16	RED	PWR
W2	J1-2	6	SP2	---	16	BLK	GND
W3	SP1	---	P10-1	2	18	RED	RU 15 (PWR)
W4	SP1	---	P10-3	2	18	RED	RU 15 (PWR)
W5	SP2	---	P10-2	2	18	BLK	RU 15 (GND)
W6	SP2	---	P10-4	2	18	BLK	RU 15 (GND)
W7	SP1	---	P11-1	2	18	RED	RU 14 (PWR)
W8	SP1	---	P11-3	2	18	RED	RU 14 (PWR)
W9	SP2	---	P11-2	2	18	BLK	RU 14 (GND)
W10	SP2	---	P11-4	2	18	BLK	RU 14 (GND)

STRAPPING TABLE

CONNECTOR	PIN 5	PIN 6	PIN 7	PIN 8	PIN 9	PIN 10	PIN 11	PIN 12
P10	GND	GND	GND	GND	---	---	GND	GND
P11	---	GND	GND	GND	---	---	---	GND

24V POWER HARNESS (P/N: 10132101)

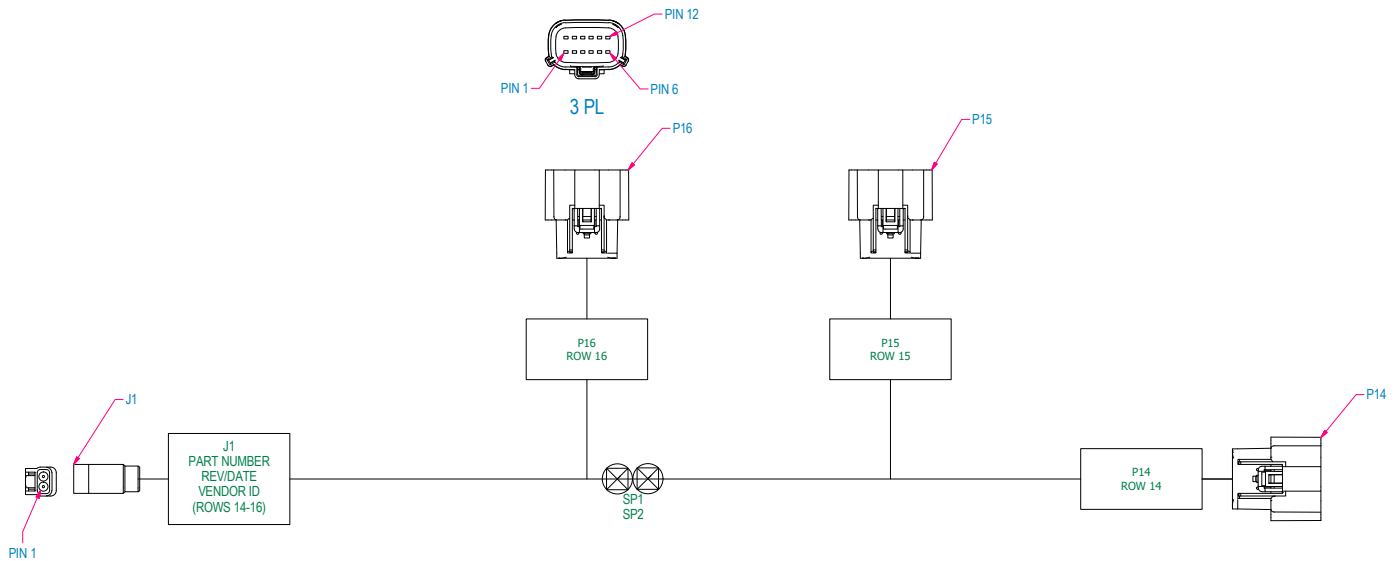

WIRE HOOKUP CHART

REF DES	FROM	USED W/	TO	USED W/	GAUGE	COLOR	FUNCTION
W1	J1-1	6	SP1	---	16	RED	PWR
W2	J1-2	6	SP2	---	16	BLK	GND
W3	SP1	---	P16-1	2	18	RED	RU 16 (PWR)
W4	SP1	---	P16-3	2	18	RED	RU 16 (PWR)
W5	SP2	---	P16-2	2	18	BLK	RU 16 (GND)
W6	SP2	---	P16-4	2	18	BLK	RU 16 (GND)
W7	SP1	---	P15-1	2	18	RED	RU 15 (PWR)
W8	SP1	---	P15-3	2	18	RED	RU 15 (PWR)
W9	SP2	---	P15-2	2	18	BLK	RU 15 (GND)
W10	SP2	---	P15-4	2	18	BLK	RU 15 (GND)
W11	SP1	---	P14-1	2	18	RED	RU 14 (PWR)
W12	SP1	---	P14-3	2	18	RED	RU 14 (PWR)
W13	SP2	---	P14-2	2	18	BLK	RU 14 (GND)
W14	SP2	---	P14-4	2	18	BLK	RU 14 (GND)

STRAPPING TABLE

CONNECTOR	PIN 5	PIN 6	PIN 7	PIN 8	PIN 9	PIN 10	PIN 11	PIN 12
P14	---	GND	GND	GND	---	---	---	GND
P15	GND	GND	GND	GND	---	---	GND	GND
P16	---	---	---	---	GND	---	---	GND



**24V POWER HARNESS (P/N: 10132301)**

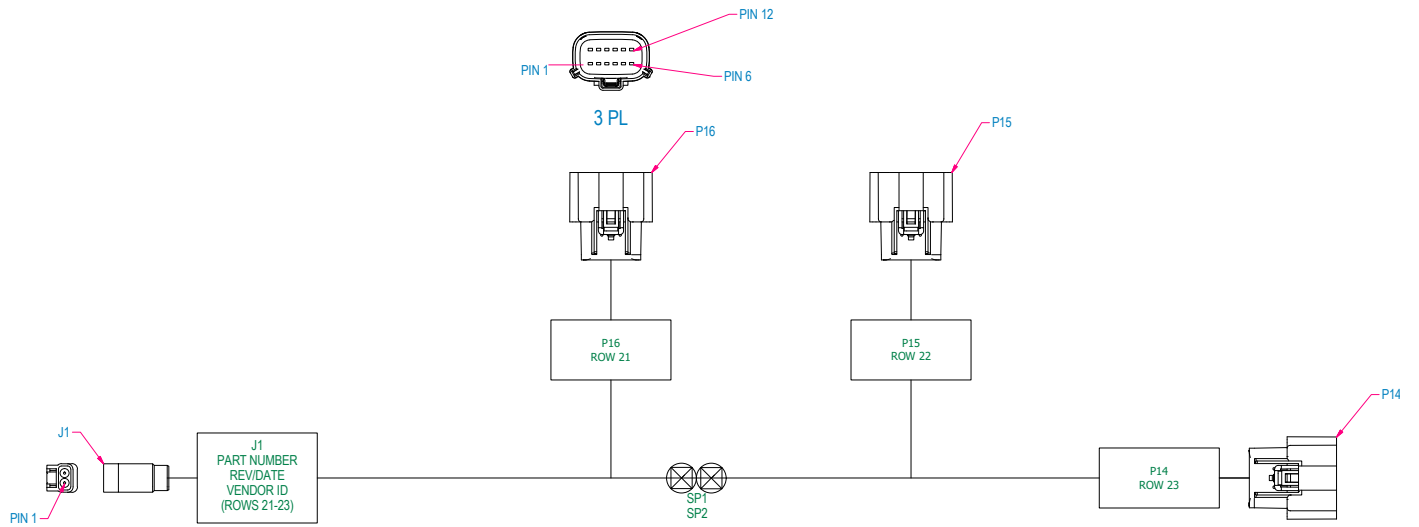

WIRE HOOKUP CHART								STRAPPING TABLE								
REF DES	FROM	USED W/	TO	USED W/	GAUGE	COLOR	FUNCTION	CONNECTOR	PIN 5	PIN 6	PIN 7	PIN 8	PIN 9	PIN 10	PIN 11	PIN 12
W1	J1-1	6	SP1	---	16	RED	PWR	P14	GND	GND	GND	---	GND	---	GND	GND
W2	J1-2	6	SP2	---	16	BLK	GND		---	GND	GND	---	GND	---	---	---
W3	SP1	---	P16-1	2	18	RED	RU 16 (PWR)	P15	---	GND	GND	---	GND	---	---	GND
W4	SP1	---	P16-3	2	18	RED	RU 16 (PWR)		GND	---	---	---	GND	---	---	---
W5	SP2	---	P16-2	2	18	BLK	RU 16 (GND)	P16	GND	---	GND	---	GND	---	---	GND
W6	SP2	---	P16-4	2	18	BLK	RU 16 (GND)		---	GND	---	---	GND	---	---	---
W7	SP1	---	P15-1	2	18	RED	RU 15 (PWR)	P14	GND	GND	GND	---	GND	---	GND	GND
W8	SP1	---	P15-3	2	18	RED	RU 15 (PWR)		---	GND	---	---	GND	---	---	---
W9	SP2	---	P15-2	2	18	BLK	RU 15 (GND)	P15	---	GND	GND	---	GND	---	---	GND
W10	SP2	---	P15-4	2	18	BLK	RU 15 (GND)		GND	---	---	---	GND	---	---	---
W11	SP1	---	P14-1	2	18	RED	RU 14 (PWR)	P16	GND	---	GND	---	GND	---	---	GND
W12	SP1	---	P14-3	2	18	RED	RU 14 (PWR)		---	GND	---	---	GND	---	---	---
W13	SP2	---	P14-2	2	18	BLK	RU 14 (GND)	P14	GND	GND	GND	---	GND	---	GND	GND
W14	SP2	---	P14-4	2	18	BLK	RU 14 (GND)		---	GND	---	---	GND	---	---	---

**DRAFT LINK POWER HARNESS (P/N: 10210601)**

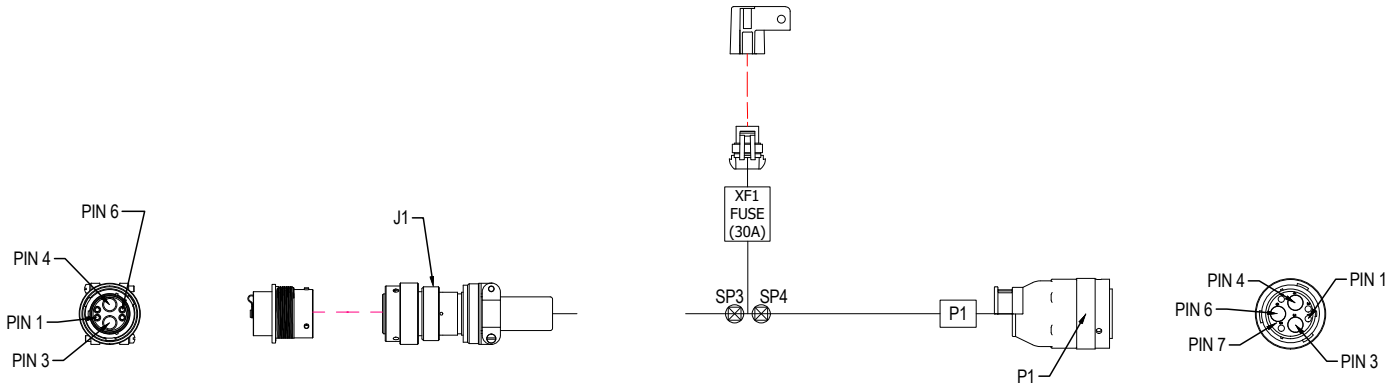

WIRE HOOKUP CHART							
REF DES	FROM	USED W/	TO	USED W/	GAUGE	COLOR	FUNCTION
W1	J1-3	7	SP-3	---	6	RED	12V DC+
W2	SP3	---	XF1-1	10	12	RED	12V DC+
W3	XF1-2	10	SP4	---	12	RED	12V DC+
W4	SP4	---	P1-3	7	6	RED	12V DC+
W5	J1-4	7	P1-4	7	6	BLK	12V DC-

**L.H. TAIL LIGHT HARNESS (P/N: 10133001)**

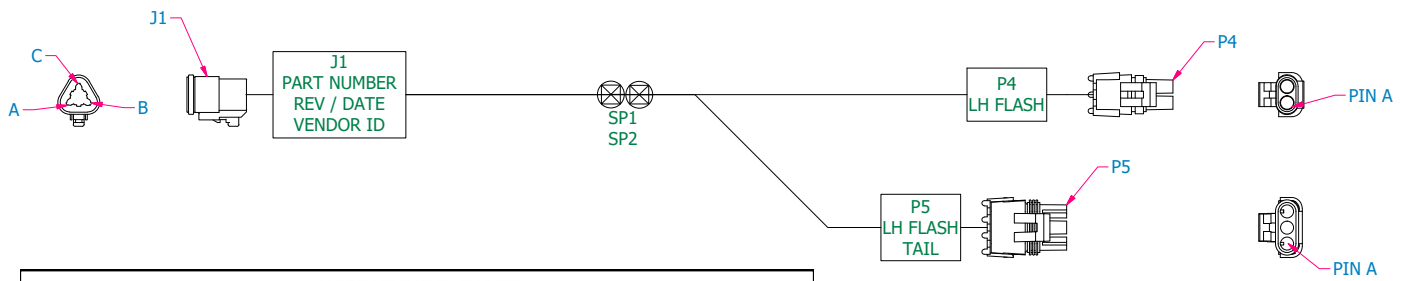

WIRE HOOKUP CHART							
REF DES	FROM	USED WITH ITEM	TO	USED WITH ITEM	GAUGE	COLOR	FUNCTION
W1	J1-A	7	SP1	--	18	WHT	GND
W2	J1-B	7	P5-C	3	18	BRN	TAIL
W3	J1-C	7	SP2	--	18	YEL	LH TURN
W4	SP1	--	P4-A	3	18	WHT	GND
W5	SP1	--	P5-A	3	18	WHT	GND
W6	SP2	--	P4-B	3	18	YEL	LH TURN
W7	SP2	--	P5-B	3	18	YEL	LH TURN

**R.H. TAIL LIGHT HARNESS (P/N: 10132901)**

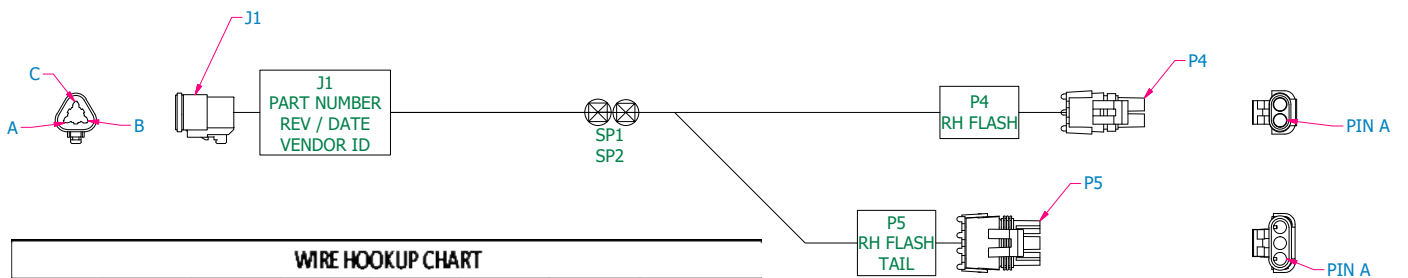

WIRE HOOKUP CHART							
REF DES	FROM	USED WITH ITEM	TO	USED WITH ITEM	GAUGE	COLOR	FUNCTION
W1	J1-A	7	SP1	--	18	WHT	GND
W2	J1-B	7	P5-C	3	18	BRN	TAIL
W3	J1-C	7	SP2	--	18	GRN	RH TURN
W4	SP1	--	P4-A	3	18	WHT	GND
W5	SP1	--	P5-A	3	18	WHT	GND
W6	SP2	--	P4-B	3	18	GRN	RH TURN
W7	SP2	--	P5-B	3	18	GRN	RH TURN

**TAIL LIGHT HARNESS (P/N: A26379)**

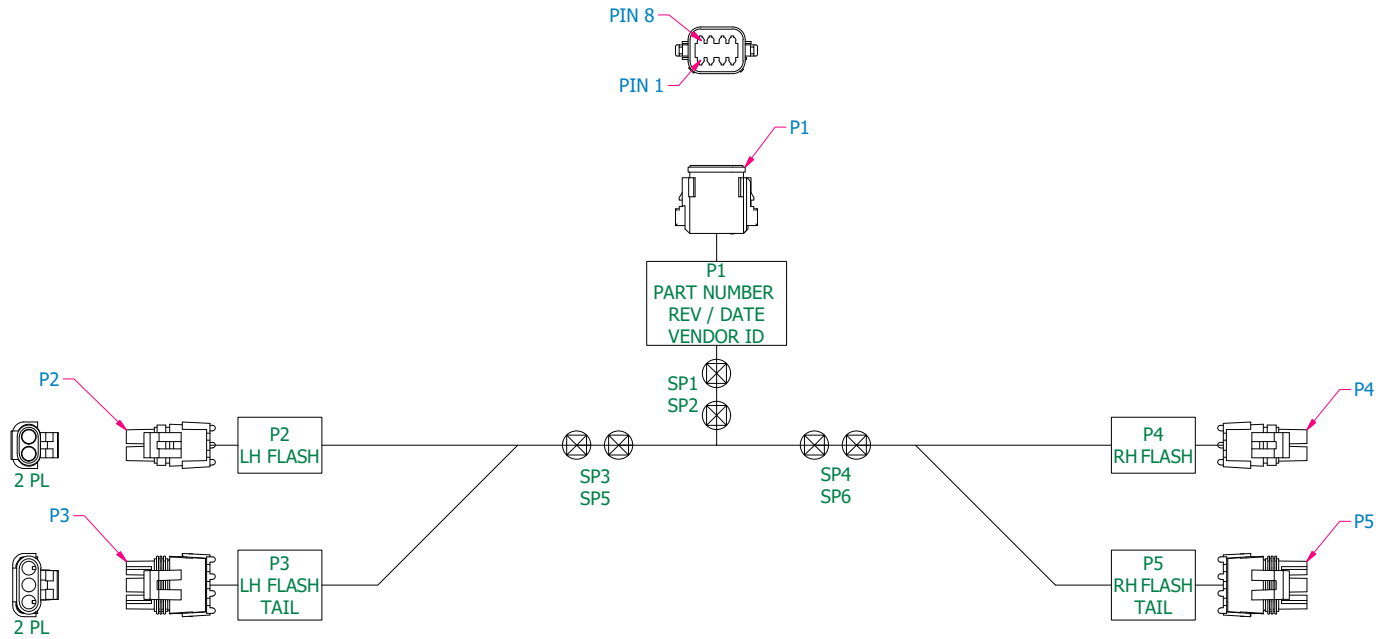

WIRE HOOKUP CHART

REF DES	FROM	USED WITH ITEM	TO	USED WITH ITEM	GAUGE	COLOR	FUNCTION
W1	P1-1	4	SP1	---	18	WHT	GND
W2	P1-6	4	SP2	---	18	BRN	TAIL
W3	SP1	---	SP3	---	18	WHT	GND
W4	SP1	---	SP4	---	18	WHT	GND
W5	SP2	---	P3-C	5	18	BRN	TAIL
W6	SP2	---	P5-C	5	18	BRN	TAIL
W7	P1-3	4	SP5	---	18	YEL	LH TURN
W9	P1-5	4	SP6	---	18	GRN	RH TURN
W8	SP3	---	P2-A	5	18	WHT	GND
W10	SP3	---	P3-A	5	18	WHT	GND
W11	SP4	---	P4-A	5	18	WHT	GND
W11	SP4	---	P5-A	5	18	WHT	GND
W12	SP5	---	P2-B	5	18	YEL	LH TURN
W13	SP5	---	P3-B	5	18	YEL	LH TURN
W14	SP6	---	P4-B	5	18	GRN	RH TURN
W15	SP6	---	P5-B	5	18	GRN	RH TURN

**TAIL LIGHT HARNESS (P/N: 10132801)**

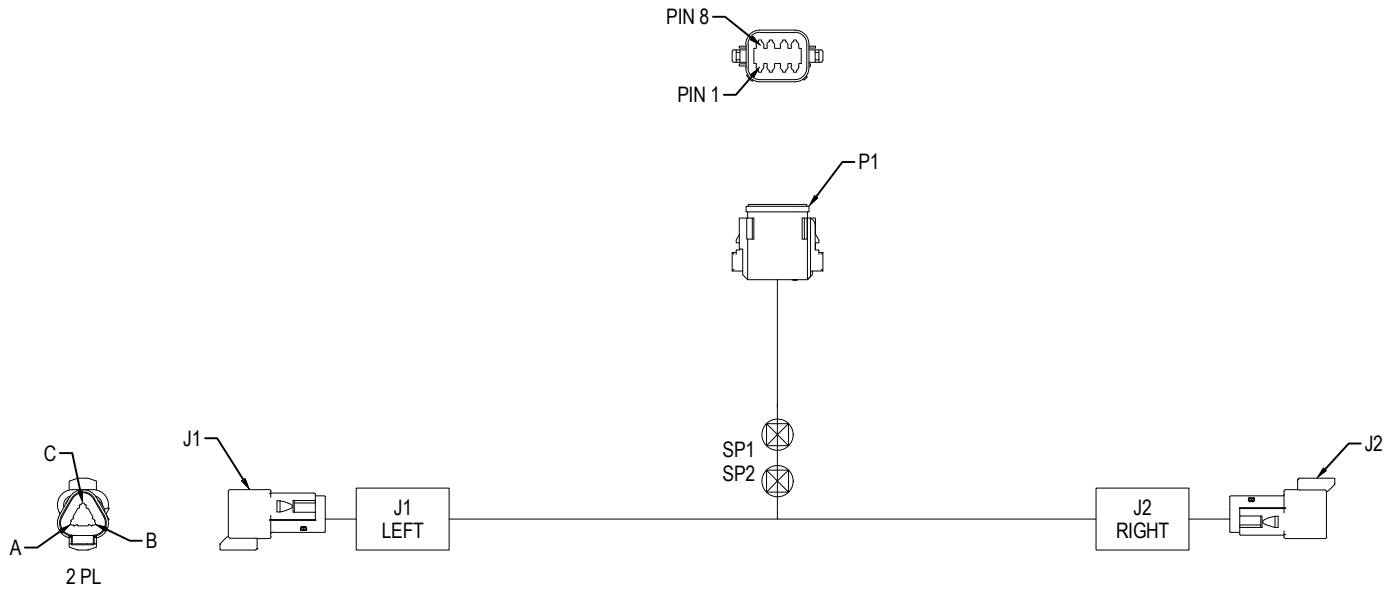

WIRE HOOKUP CHART							
REF DES	FROM	USED WITH ITEM	TO	USED WITH ITEM	GAUGE	COLOR	FUNCTION
W1	P1-1	2	SP1	---	18	WHT	GND
W2	P1-6	2	SP2	---	18	BRN	TAIL
W3	SP1	---	J1-A	7	18	WHT	GND
W4	SP1	---	J2-A	7	18	WHT	GND
W5	SP2	---	J1-B	7	18	BRN	TAIL
W6	SP2	---	J2-B	7	18	BRN	TAIL
W7	P1-3	4	J1-C	7	18	YEL	LH TURN
W9	P1-5	4	J2-C	7	18	GRN	RH TURN

**DRAWBAR HITCH HARNESS (P/N: A26341)**

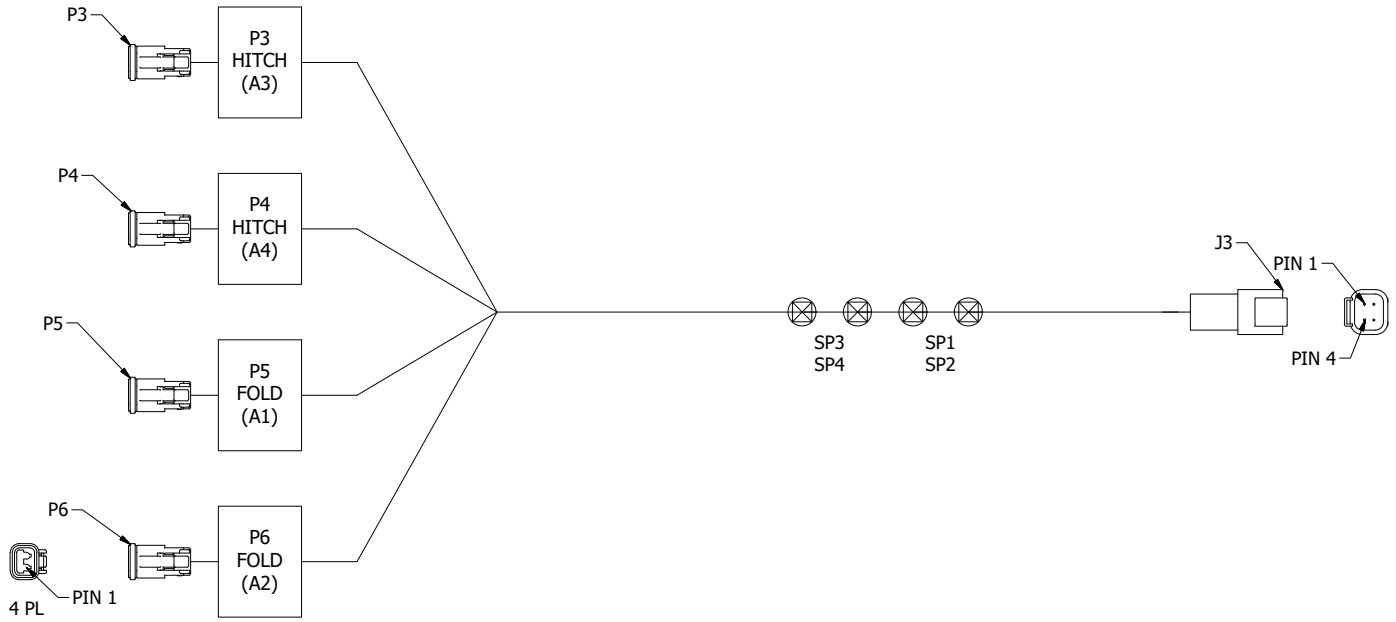

WIRE HOOKUP CHART							
REF DES	FORM	USED W/	TO	USED W/	GAUGE	COLOR	FUNCTION
W1	J3-1	4	SP1	—	16	WHT	DRAWBAR HITCH SOLENOID (+)
W2	J3-2	4	SP2	—	16	GRN	DRAWBAR HITCH SOLENOID (-)
W3	J3-3	4	SP3	—	16	RED	WING FOLD SOLENOID (+)
W4	J3-4	4	SP4	—	16	BLK	WING FOLD SOLENOID (-)
W5	SP1	—	P3-1	6	16	WHT	DRAWBAR HITCH SOLENOID (+)
W6	SP1	—	P4-1	6	16	WHT	DRAWBAR HITCH SOLENOID (+)
W7	SP2	—	P3-2	6	16	GRN	DRAWBAR HITCH SOLENOID (-)
W8	SP2	—	P4-2	6	16	GRN	DRAWBAR HITCH SOLENOID (-)
W9	SP3	—	P5-1	6	16	RED	WING FOLD SOLENOID (+)
W10	SP3	—	P6-1	6	16	RED	WING FOLD SOLENOID (+)
W11	SP4	—	P5-2	6	16	BLK	WING FOLD SOLENOID (-)
W12	SP4	—	P6-2	6	16	BLK	WING FOLD SOLENOID (-)

FERTILIZER IPN HARNESS (P/N: 10765602)

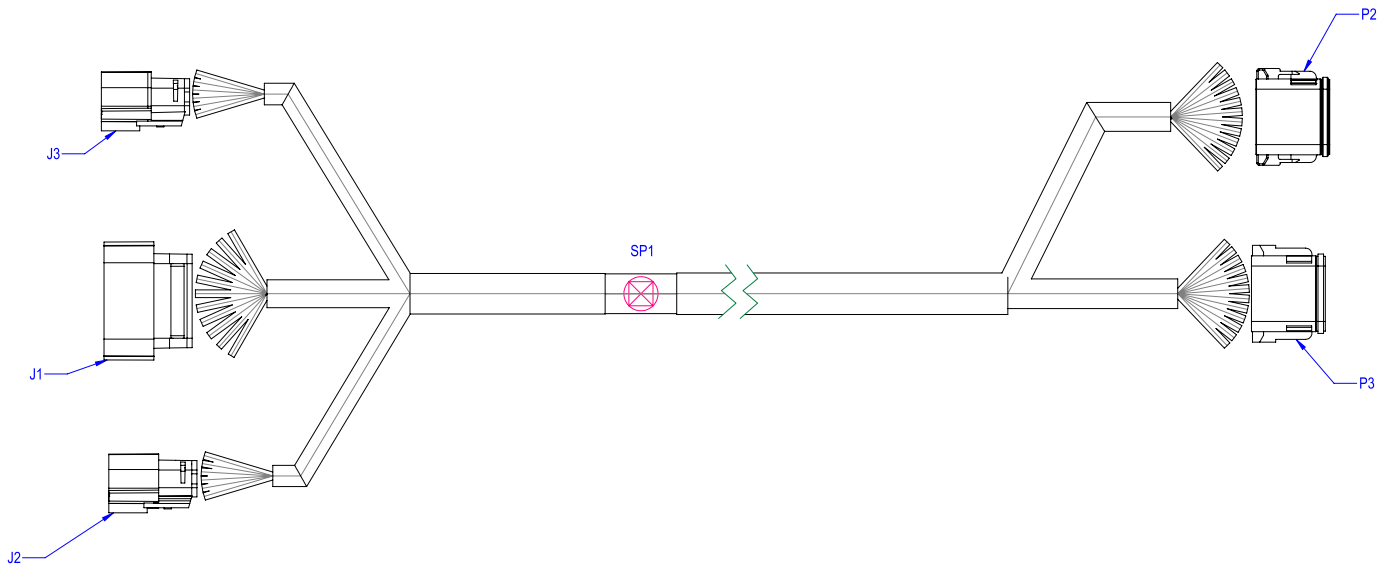

WIRE HOOKUP CHART							FUNCTION	
REF DES	FROM	USED W/	TO	USED W/	GAUGE	COLOR		
W1	J1:17	6	P3:2	8	16	BLK	FERT LOW LEVEL SENSOR (GND)	
W2	SP1:OUT	---	P2:11	8	16	RED	FERT LOW LEVEL SENSOR (PWR)	
W3	SP1:OUT	---	P3:5	8	16	RED	FERT FLOW METER (PWR)	
W4	J1:3	6	P3:12	8	16	RED	FERT PRESS REGULATOR (+)	
W5	J1:4	6	P3:11	8	16	BLK	FERT PRESS REGULATOR (-)	
W6	J1:13	6	P3:10	8	16	WHT	FERT RAIL PRESSURE SENSOR INPUT (ANALOG)	
W7	J1:19	6	P3:9	8	16	BLK	FERT RAIL PRESS SENSOR (GND)	
W8	J1:20	6	P3:8	8	16	RED	FERT RAIL PRESS SENSOR (PWR)	
W9	J1:15	6	P3:7	8	16	YEL	FERT FLOW METER (FREQ)	
W10	J1:16	6	P3:6	8	16	CRN	FERT LOW LEVEL SENSOR (DIGITAL)	
W11	J2:5	6	P3:4	8	16	RED	FERT PUMP INLET SUCTION SENSOR (PWR)	
W12	J1:18	6	SP1:IN	---	16	RED	FERT TANK LOW LEVEL (PWR)/FLOW METER (12V) (PWR)	
W13	J2:4	6	P3:3	8	16	BLK	FERT PUMP INLET SUCTION SENSOR (GND)	
W14	J2:8	6	P3:1	8	16	YEL	FERT PUMP INLET SUCTION SENSOR (ANALOG)	
W15	J2:1	6	P2:8	8	16	VLT	FERT SYSTEM SHUTOFF VALVE (+)	
W16	J2:2	6	P2:7	8	16	BLK	FERT SYSTEM SHUTOFF VALVE (-)	
W17	J3:1	6	P2:6	8	16	RED	FERTILIZER PUMP (+)	
W18	J3:2	6	P2:5	8	16	BLK	FERTILIZER PUMP (-)	
W19	J3:5	6	P2:4	8	16	RED	FERT PUMP RPM SENSOR (PWR)/FERT PUMP INLET FLUID SWITCH (PWR)	
W20	J3:6	6	P2:3	8	16	BLK	FERT PUMP RPM SENSOR/ FERT PUMP INLET FLUID SWITCH/ FERT FLOW METER (GND)	
W21	J3:7	6	P2:2	8	16	BLU	FERTILIZER PUMP INLET FLUID SWITCH (DIGITAL)	
W22	J3:8	6	P2:1	8	16	YEL	FERTILIZER PUMP RPM SENSOR INPUT (FREQ)	
W23	J1:7	6	P2:10	8	18	CRN	FERTILIZER FLOW METER TRANSITION VALVE + PWM	
W24	J1:8	6	P2:9	8	18	GRY	FERTILIZER FLOW METER TRANSITION VALVE - PWM	
W25	J2:7	6	P2:12	8	18	BRN	FERTILIZER LOWER FLOW METER (FREQ) [SIG] (1k ohm PU to 12V)	

LABEL TABLE			
CONNECTOR	CONNECTOR LABEL	CONNECTOR	CONNECTOR LABEL
J1	TO IPN J7	P2	TO FERT MODULE J2
J2	TO IPN J5	P3	TO FERT MODULE J3
J3	TO IPN J4	HARNESS LABEL	PART NUMBER REV / DATE VENDOR I.D.

FERTILIZER IPN HARNESS (P/N: 10210602)

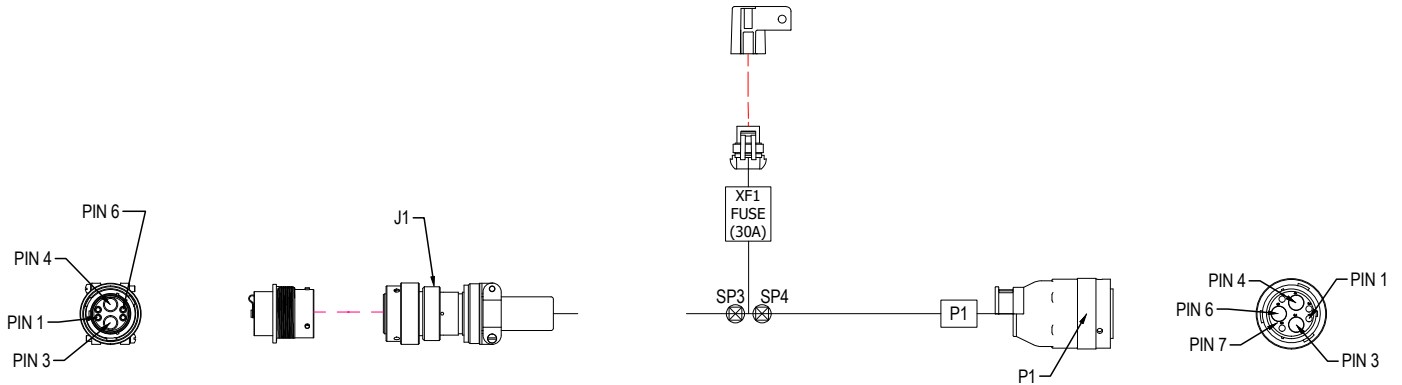

WIRE HOOKUP CHART							
REF DES	FROM	USED W/	TO	USED W/	GAUGE	COLOR	FUNCTION
W1	J1-3	7	SP-3	---	6	RED	12V DC+
W2	SP3	---	XF1-1	10	12	RED	12V DC+
W3	XF1-2	10	SP4	---	12	RED	12V DC+
W4	SP4	---	P1-3	7	6	RED	12V DC+
W5	J1-4	7	P1-4	7	6	BLK	12V DC-



**AIR CLOSING WHEEL HARNESS (P/N: 10806201)**

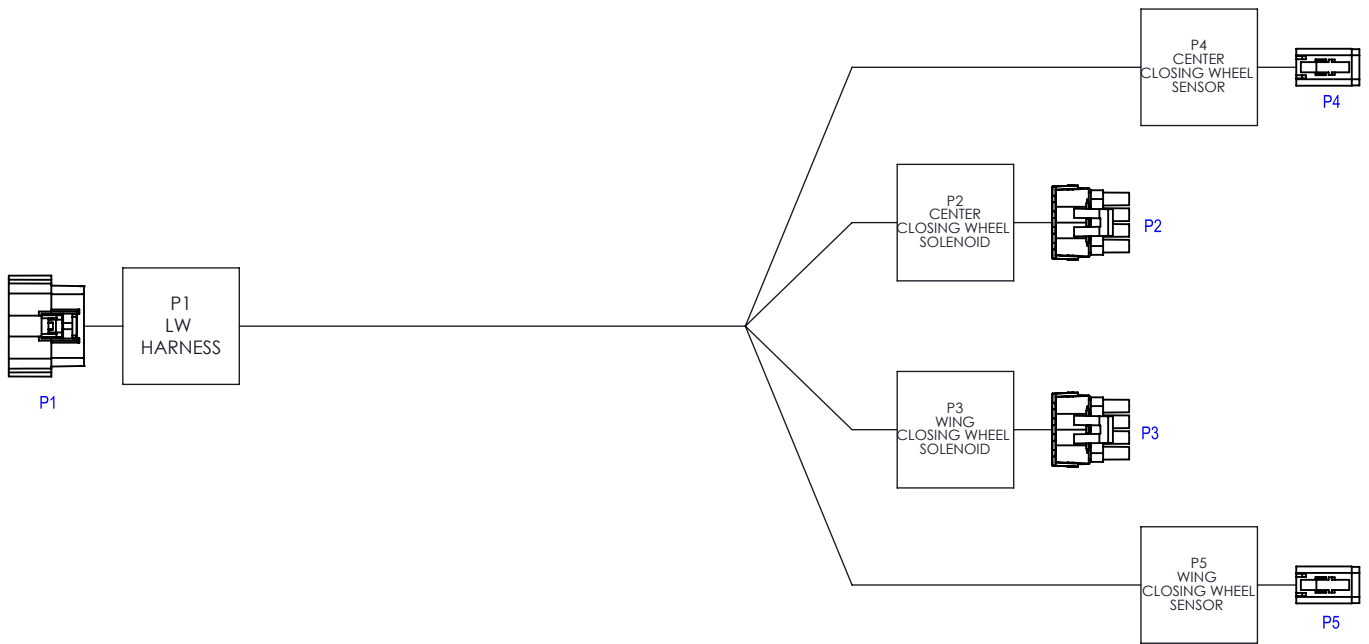

WIRE HOOKUP CHART							
REF DES	FROM	USE W/	TO	USED W/	GAUGE	COLOR	FUNCTION
W1	P1:1	4	P5:1	8	18	BLK	WING CLOSING WHEEL SENSOR (GND)
W2	P1:2	4	P5:2	8	18	RED	WING CLOSING WHEEL SENSOR (12V PWR)
W3	P1:4	4	P5:4	8	18	BLU	WING CLOSING WHEEL SENSOR (ANALOG)
W4	P1:6	4	P3:A	6	18	ORN	WING CLOSING WHEEL INCREASE (+)
W5	P1:7	4	P3:B	6	18	BLK	WING CLOSING WHEEL INCREASE (-)
W6	P1:8	4	P3:C	6	18	ORN	WING CLOSING WHEEL DECREASE (+)
W7	P1:9	4	P3:D	6	18	BLK	WING CLOSING WHEEL DECREASE (-)
W8	P1:11	4	P4:2	8	18	RED	CENTER CLOSING WHEEL SENSOR (12V PWR)
W9	P1:12	4	P4:1	8	18	BLK	CENTER CLOSING WHEEL SENSOR (GND)
W10	P1:13	4	P4:4	8	18	YEL	CENTER CLOSING WHEEL SENSOR (ANALOG)
W11	P1:15	4	P2:A	6	18	ORN	CENTER CLOSING WHEEL INCREASE (+)
W12	P1:16	4	P2:B	6	18	BLK	CENTER CLOSING WHEEL INCREASE (-)
W13	P1:17	4	P2:C	6	18	ORN	CENTER CLOSING WHEEL DECREASE (+)
W14	P1:18	4	P2:D	6	18	BLK	CENTER CLOSING WHEEL DECREASE (-)

FOLD IPN HARNESS (P/N: 10741101 / 10741102)

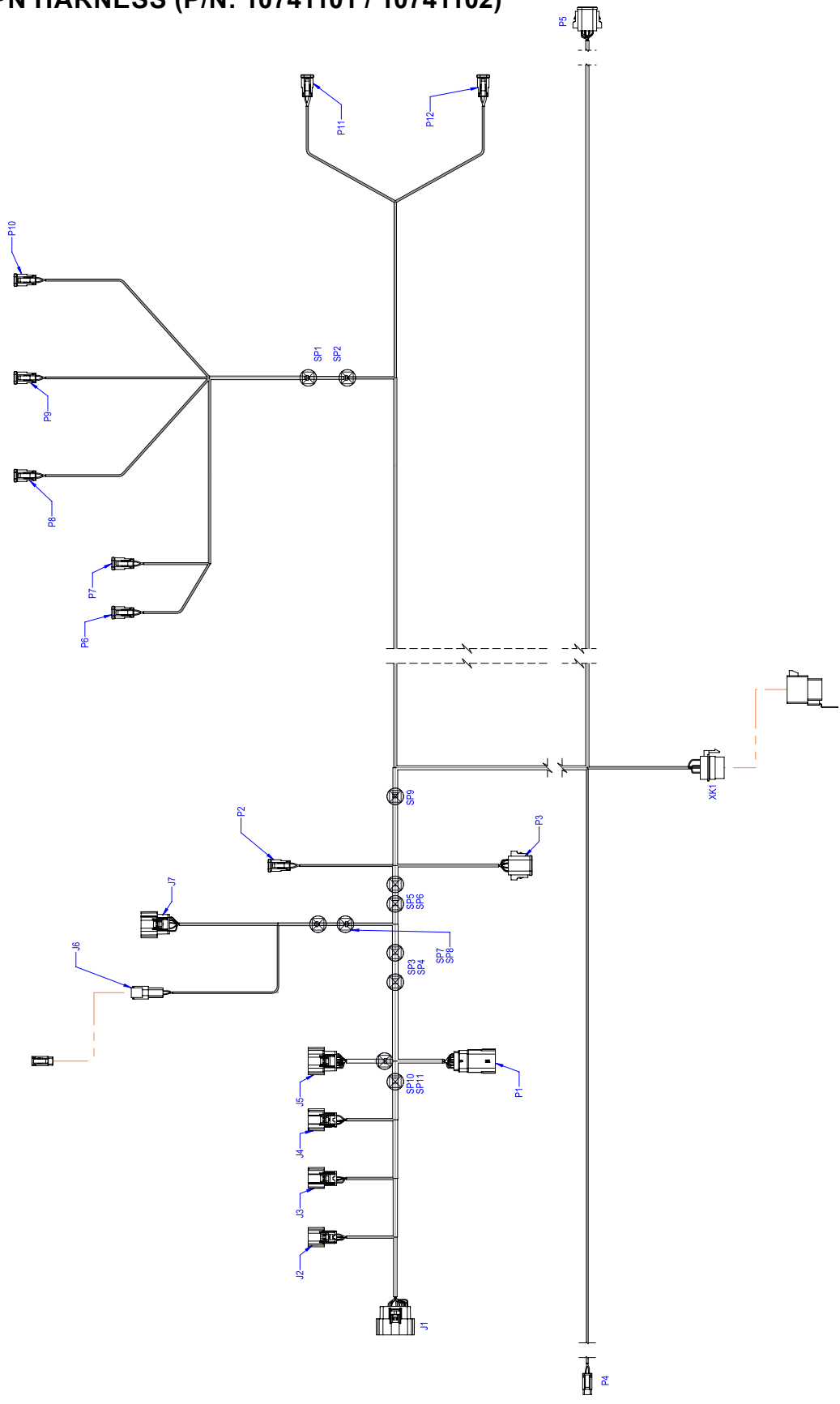

WIRE HOOKUP CHART															
REF DES	FROM	USED W/	TO	USED W/	GAUGE	COLOR	FUNCTION	REF DES	FROM	USED W/	TO	USED W/	GAUGE	COLOR	FUNCTION
W1	J1-1	17	J7-1	17	18 (TP)	BRN	IPP UPDATE (DEBUG (RS232RX))	W41	SP2	---	P3-2	14	16	BLK	AXLE (-)
W2	J1-2	17	J7-2	17	18 (TP)	BRN	IPP UPDATE (DEBUG (RS232RX))	W42	SP4	---	P3-8	14	16	BLK	FOLD (-)
W3	J1-3	15	SP3	---	16	RED	FOLD (+)	W43	SP3	---	P11-1	14	16	RED	FOLD (+)
W4	J1-4	15	SP4	---	16	BLK	FOLD (-)	W44	SP3	---	P12-1	14	16	RED	FOLD (+)
W5	J1-5	15	SPI0	---	16	RED	AXLE RELAY INPUT (-)	W45	SP4	---	P11-2	14	16	BLK	FOLD (-)
W6	J1-6	15	SPI9	---	16	BLK	AXLE RELAY (+)	W46	SP4	---	P12-2	14	16	BLK	FOLD (-)
W7	J1-13	17	P5-4	14	20	REL	RU PWR FEEDBACK FROM PWR PACK	W47	SP4	---	P10-1	14	16	BLK	FOLD (-)
W8	J1-14	15	P5-7	11	18	ORN	BATTERY 1 VOLTAGE	W48	SP7	---	J7-5	17	18 (TP)	YEL	AXLE RELAY OUTPUT (+)
W9	J1-16	15	P5-8	11	18	BLU	BATTERY 2 VOLTAGE	W49	SP8	---	J7-4	17	18 (TP)	GRN	IPP CAN H
W10	J1-19	15	P5-2	14	16	BLK	RU POWER RELAY (GND)	W50	SP8	---	J6-1	16	18 (TP)	YEL	IPP CAN L
W11	J1-20	15	P5-1	14	16	RED	RU POWER RELAY (PWR)	W51	SP8	---	J6-2	16	18 (TP)	GRN	CAN HI TERMINATOR
W12	J2-1	17	SP7	---	18 (TP)	YEL	IPP CAN HI	W52	SP9	---	XK1-85	---	16	BLK	CAN LO TERMINATOR
W13	J2-2	17	SP8	---	18 (TP)	GRN	IPP CAN LO	W53	P4-2	23	XK1-86	---	16	BLU	AXLE RELAY (-)
W14	J2-3	15	J7-12	15	16	RED	IPP PWR (+)	W54	P1-1	27	SP11	14	16	RED	SIGNAL
W15	J2-4	15	J7-6	15	16	BLK	IPP PWR (-)	W55	SP11	---	P5-5	15	16	RED	FOLD IN PWR 12V
W16	J2-5	17	J7-11	17	18	BLU	IPP SOFTWARE UPDATE ENABLE	W56	SP11	---	J5-1	15	16	RED	BATTERY PACK RELAY (PWR)
W17	J3-1	15	SP1	---	16	RED	IPP SOFTWARE UPDATE DISABLE	W57	P1-2	27	J6-3	15	16	RED	FOLD IN PWR 12V (-)
W18	J3-2	15	SP2	---	16	BLK	AXLE (+)	W58	P1-3	27	J6-4	15	16	RED	FOLD IN PWR 12V (+)
W19	J3-6	15	P5-6	14	16	GRN	BATTERY PACK RELAY (GND)	W59	P1-4	27	J5-4	15	16	BLK	FOLD IN PWR 12V (-)
W20	J3-7	17	P3-3	14	18	WHT	SPEED WHEEL #1 (FREQ)	W60	P1-5	27	J5-5	15	16	BLK	FOLD IN PWR 12V (+)
W21	J4-1	15	SP5	---	16	RED	WING LATCHES (+)	W61	P1-6	27	J5-6	15	16	BLK	STRAPPING
W22	J4-2	15	SP6	---	16	BLK	WING LATCHES (-)	W62	P1-7	27	J5-7	15	16	BLK	STRAPPING
W23	J4-5	17	P3-1	14	18	RED	SPEED WHEEL #1 (PWR)	W63	P1-8	27	J5-8	15	16	BLK	STRAPPING
W24	J4-6	17	P3-2	14	18	BLK	SPEED WHEEL #1 (GND)	W64	P1-9	27	J5-9	15	16	BLK	STRAPPING
W25	J4-8	15	P5-3	14	16	BRN	ALTERNATOR SENSE (FREQ)	W65	P1-10	27	J5-10	15	16	BLK	STRAPPING
W26	SPI0	---	P4-1	23	16	RED	AXLE RELAY INPUT (+)	W66	P1-11	27	J5-11	15	16	BLK	STRAPPING
W27	SPI0	---	XK1-30	---	16	RED	AXLE RELAY INPUT (-)	W67	P1-12	27	J5-12	15	16	BLK	STRAPPING
W28	SPI5	---	P2-2	14	16	RED	AXLE RELAY INPUT (+)								
W29	SPI1	---	P6-1	14	16	RED	RIGHT WING LATCH (+)								
W30	SPI1	---	P7-1	14	16	RED	AXLE (+)								
W31	SPI5	---	P3-4	14	16	RED	LEFT WING LATCH (+)								
W32	SPI6	---	P2-1	14	16	BLK	RIGHT WING LATCH (-)								
W33	SPI2	---	P6-2	14	16	BLK	AXLE (-)								
W34	SPI2	---	P2-2	14	16	BLK	AXLE (+)								
W35	SPI6	---	P3-5	14	16	BLK	LEFT WING LATCH (-)								
W36	SPI9	---	P10-2	14	16	BLK	AXLE RELAY (-)								
W37	SPI1	---	P8-1	14	16	RED	AXLE (+)								
W38	SPI1	---	P9-1	14	16	RED	AXLE (+)								
W39	SPI3	---	P3-7	14	16	RED	AXLE (+)								
W40	SPI2	---	P8-2	14	16	BLK	AXLE (-)								

LABEL TABLE				
J1	J1 FOLD IPN J7	P3	P3 WHEEL SPEED	
J2	J2 FOLD IPN J6	P4	P4 IMP SWITCH AXLE	
J3	J3 FOLD IPN J5	P5	P5 PWR PACK	
J4	J4 FOLD IPN J4	P6	P6 CENTER VALVE (B1)	
J5	J5 FOLD IPN PWR	P7	P7 CENTER VALVE (B2)	
J6	J6 CAN TERM.	P8	P8 CENTER VALVE (A1)	
J7	J7 IPP	P9	P9 CENTER VALVE (A4)	
XK1	XK1 AXLE RELAY	P10	P10 CENTER VALVE (A6)	
P1	P1 PWR PASS	P11	P11 CENTER VALVE (D4)	
P2	P2 RIGHT WING	P12	P12 CENTER VALVE (D2)	

12V POWER HARNESS (P/N: 10740901 / 10740902)

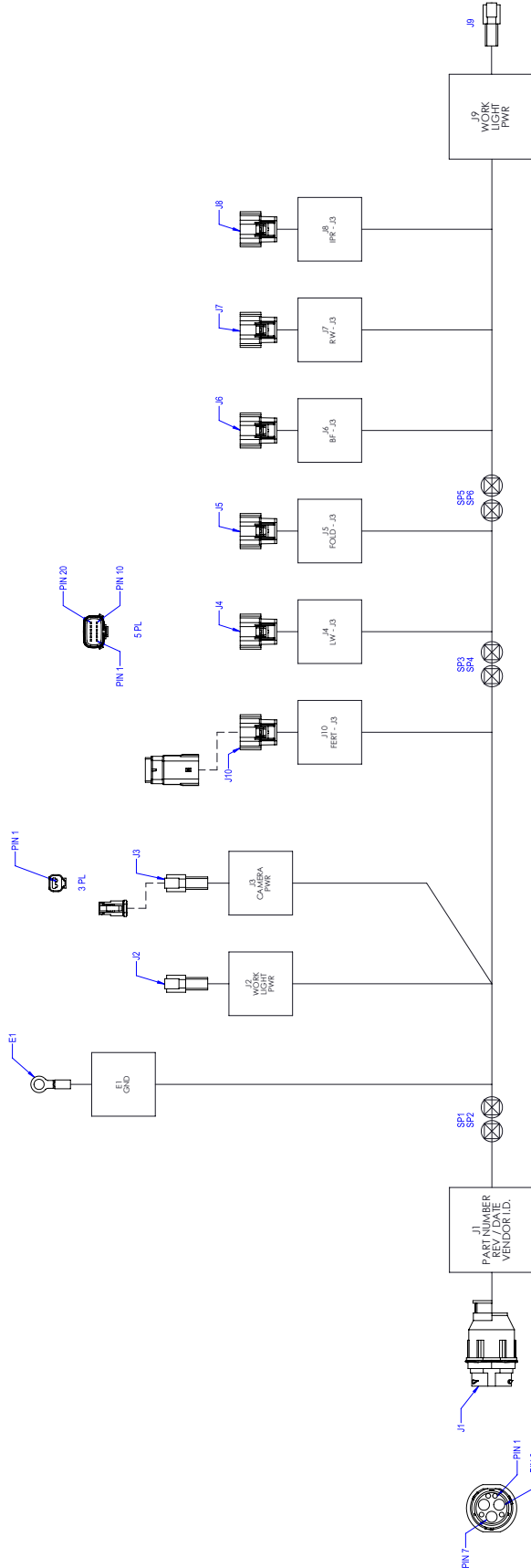

WIRE HOOKUP CHART					
REF DES	FROM	USED W/	TO	USED W/	DESCRIPTION
W1	J1-3	6	SP1	...	12V(DC(+))
W2	J1-4	6	SP2	...	12V(DC(-))
W3	SP1	...	J2-2	10	12V(W/L(+))
W4	SP1	...	J3-2	10	12V(CAMERA(+))
W5	SP3	...	J4-4	7	12V(W(+))
W6	SP3	...	J4-3	7	12V(W(-))
W7	SP1	...	SP3	...	12V(DC(+))
W8	SP2	...	E1	...	GND
W9	SP2	...	J2-1	10	12V(W/L(-))
W10	SP2	...	J3-1	10	12V(CAMERA(-))
W11	SP4	...	J4-2	7	LW(+)
W12	SP4	...	J4-1	7	LW(-)
W13	SP2	...	SP4	...	12V(DC(-))
W14	SP3	...	J5-1	7	FOLD(+)
W15	SP3	...	J5-2	7	FOLD(-)
W16	SP3	...	J6-1	7	BF(+)
W17	SP3	...	J6-3	7	BF(-)
W18	SP3	...	SP5	...	12V(DC(+))
W19	SP4	...	J5-2	7	FOLD(+)
W20	SP4	...	J5-4	7	FOLD(-)
W21	SP4	...	J6-2	7	BF(+)
W22	SP4	...	J6-4	7	BF(-)
W23	SP4	...	SP6	...	12V(DC(-))
W24	SP5	...	J7-1	7	RW(+)
W25	SP5	...	J7-3	7	RW(-)
W26	SP5	...	IPR-1	7	IPR(+)
W27	SP5	...	IPR-3	7	IPR(-)
W28	SP5	...	J9-2	10	12V(W/L(+))
W29	SP6	...	J7-2	7	RW(+)
W30	SP6	...	J7-4	7	RW(-)
W31	SP6	...	J8-2	7	IPR(+)
W32	SP6	...	J8-4	7	IPR(-)
W33	SP6	...	J9-1	10	12V(W/L(-))
W34	SP3	...	J10-1	7	FERT(+)
W35	SP4	...	J10-2	7	FERT(-)
W36	SP4	...	J10-3	7	FERT(+)
W37	SP4	...	J10-4	7	FERT(-)

STRAPPING TABLE 1			
CONNECTOR	PIN 10	PIN 11	PIN 12
J8 (IPR)	GND	...	GND
STRAPPING TABLE 2			
CONNECTOR	PIN 5	PIN 6	PIN 7
J10(FERT)	GND	GND	...
J6(BF)	GND	GND	...
J5(FOLD)	GND	...	GND
J4(LW)	GND	...	GND

**BULK FILL IPN HARNESS (P/N: 10806401)**

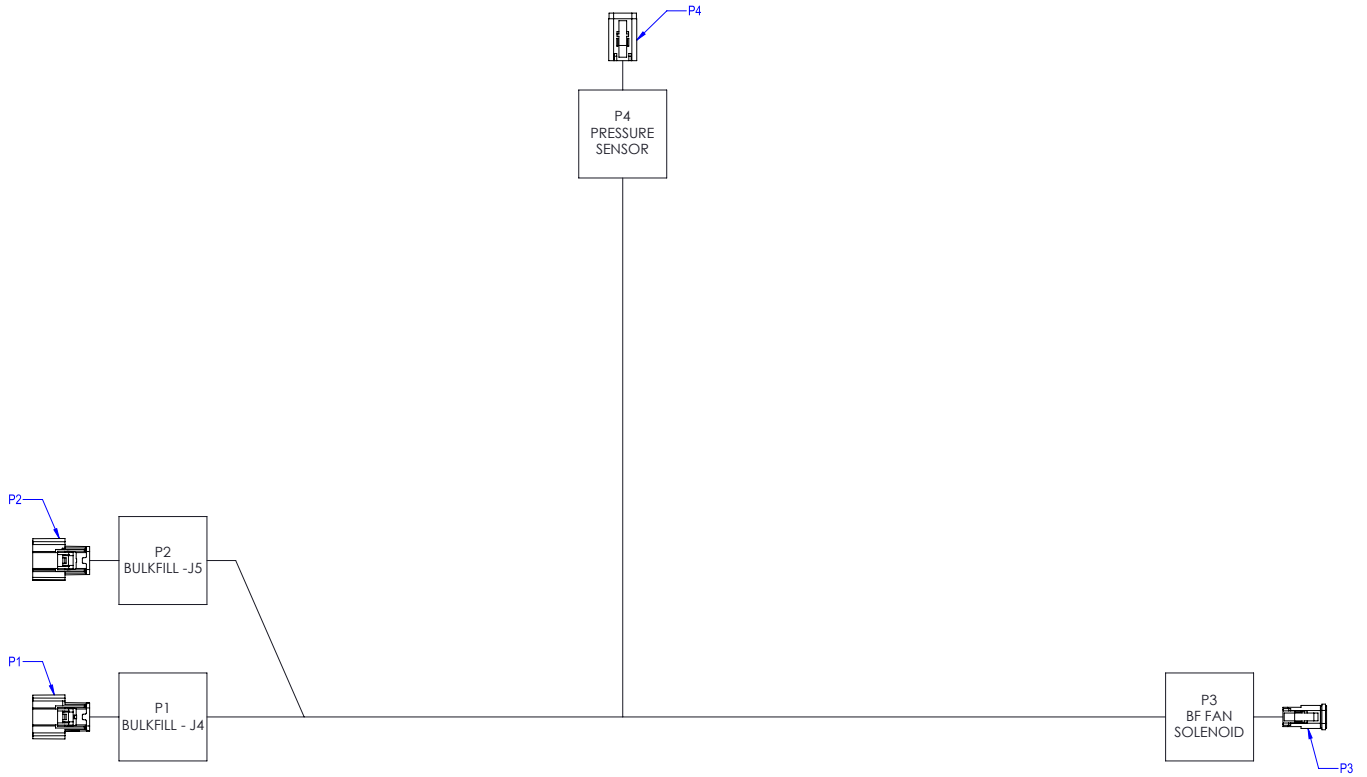

WIRE HOOKUP CHART							
REF DES	FROM	USED W/	TO	USED W/	GAUGE	COLOR	FUNCTION
W1	P2:7	7	P4:4	8	18	WHT	BULKFILL PRESSURE SENSOR (SIG)
W2	P2:5	7	P4:2	8	18	ORN	BULKFILL PRESSURE SENSOR (12V PWR)
W3	P2:6	7	P4:1	8	18	BLK	BULKFILL PRESSURE SENSOR (GND)
W4	P1:1	5	P3:1	8	16	RED	BULKFILL FAN SOLENOID PWM (+)
W5	P1:2	5	P3:2	8	16	BLK	BULKFILL FAN SOLENOID PWM (-)

**RIGHT WING IPN HARNESS (P/N: 10803201 / 10803202)**

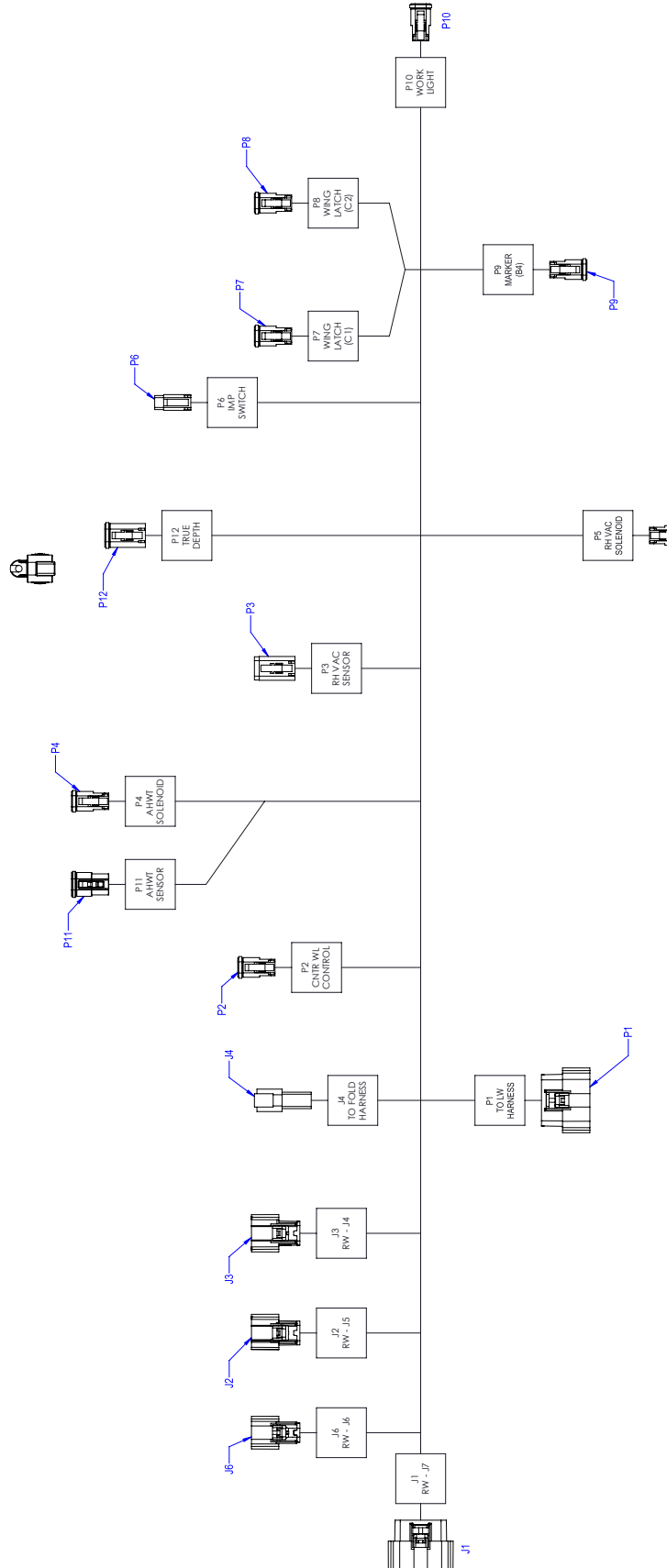

**WIRE HOOK-UP CHART**

REF DES	FROM:	USED W/	TO:	USED W/	COLOR	FUNCTION
W1	J1-3	2	P1-3	2	RED	LEFT MARKER SOLENOID (+)
W2	J1-4	2	P1-4	2	RED	LEFT MARKER SOLENOID (-)
W3	J1-7	2	P4-1	2	ORN	AHWT SOLENOID (+PWA)
W4	J1-8	2	P4-2	2	BLU	AHWT SOLENOID (-PWA)
W5	J2-1	2	P9-1	2	RED	RIGHT MARKER SOLENOID (+)
W6	J2-2	2	P9-2	2	BLK	RIGHT MARKER SOLENOID (-)
W7	J2-5	2	SP4-N	2	RED	RIGHT VAC / AHWT PRESS SENSOR (12V PWR)
W8	SP4-OUT	---	P3-2	9	RED	RIGHT VAC / AHWT PRESS SENSOR (12V PWR)
W9	SP4-OUT	---	P1-1	9	RED	RIGHT AHWT PRESS SENSOR (12V PWR)
W10	J2-6	2	SP5-IN	2	BLK	RIGHT VAC / AHWT PRESS SENSOR (GND)
W11	SP5-OUT	---	P3-1	9	BLK	RIGHT VAC PRESS SENSOR (GND)
W12	SP5-OUT	---	P1-2	9	BLK	AHWT PRESS SENSOR (GND)
W13	J2-8	5	P1-12	5	BLK	RIGHT VAC PRESS SENSOR (SIG)
W14	J2-9	5	P1-13	5	GRN	AHWT PRESS SENSOR (SIG)
W15	13-1	2	P5-1	2	RED	RIGHT VAC FAN(S) SOLENOID (+PWA)
W16	13-2	2	P5-2	2	BLK	RIGHT VAC FAN(S) SOLENOID (-PWA)
W17	13-5	2	SP1-IN	2	RED	RIGHT IMP SWITCH / CENTER CLOSING WHEEL SENSOR (12V PWR)
W18	SP1-OUT	---	P5-1	2	RED	RIGHT IMP SWITCH / CENTER CLOSING WHEEL SENSOR (12V PWR)
W19	SP2-IN	18	SP2-IN	2	RED	RIGHT WING LATCH (+)
W20	4-2	18	SP3-IN	2	BLK	RIGHT WING LATCH (-)
W21	SP2-OUT	---	P7-1	9	RED	RIGHT WING LATCH (+)
W22	SP2-OUT	---	P8-1	9	RED	RIGHT WING LATCH (-)
W23	SP3-OUT	---	P7-2	9	BLK	RIGHT WING LATCH (+)
W24	SP3-OUT	---	P8-2	9	BLK	RIGHT WING LATCH (-)
W25	P1-1	2	P10-2	2	RED	WING WORKLIGHT RH (+)
W26	P1-2	2	P10-1	2	BLK	WING WORKLIGHT RH (-)
W27	J1-20	2	P2-2	2	WHT	CENTER WORK LIGHT RELAY (+)
W28	J1-19	2	P2-1	2	GRN	CENTER WORK LIGHT RELAY (-)
W29	SP1-OUT	---	P2-1	2	RED	CENTER CLOSING WHEEL SENSOR (12V PWR)
W30	13-1	2	P4-1	2	BLK	RIGHT WING LATCH (+)
W31	13-8	2	P1-13	2	YEL	CENTER CLOSING WHEEL SENSOR (ANALOG)
W32	13-6	2	P1-12	2	BLK	CENTER CLOSING WHEEL SENSOR (GND)
W33	J6-3	2	P1-17	2	ORN	CENTER CLOSING WHEEL DECREASE (+)
W34	J6-4	2	P1-18	2	BLK	CENTER CLOSING WHEEL DECREASE (-)
W35	J6-5	2	P1-15	2	ORN	CENTER CLOSING WHEEL INCREASE (+)
W36	J6-6	2	P1-16	2	BLK	CENTER CLOSING WHEEL INCREASE (-)
W37	P1-5	2	P1-21	2	WHT	HYD DOWN FORCE PRESS SENSOR (ANALOG)
W38	P1-6	2	P1-22	2	PNK	HYD DOWN FORCE PRESS SENSOR (12V PWR)
W39	P1-7	2	P1-23	2	BLK	HYD DOWN FORCE PRESS SENSOR (GND)
W40	P1-8	2	P1-25	2	BRN	HYD DOWN FORCE SOLENOID (+PWA)
W41	P1-9	2	P1-24	2	VLT	HYD DOWN FORCE SOLENOID (-PWA)

LEFT WING IPN HARNESS (P/N: 10803301/ 10803302)

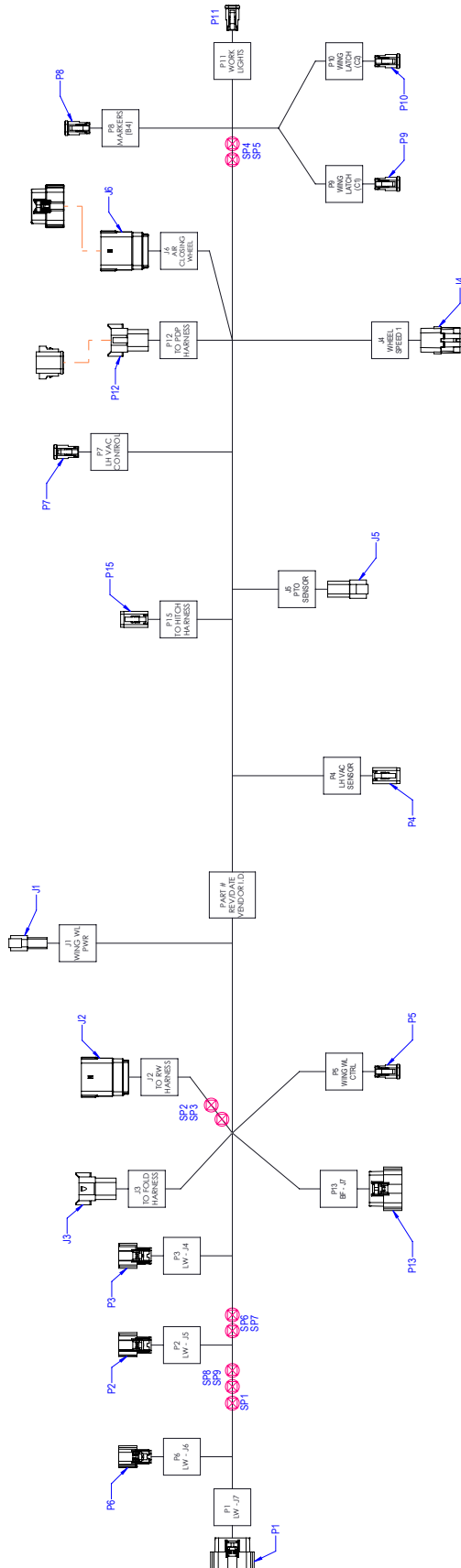

WIRE HOOKUP CHART

BREEDIES	FROM	USED W/	TO	USED W/	COLOR	FUNCTION	FROM	USED W/	TO	USED W/	CALICE	COLOR	FUNCTION
W1	P1-3	4	SP1N	---	BLK	PDP / HDP INCREASE (+)	W34	---	P127	---	18	BLK	PDP SENSOR (12V PWR)
W2	P1-4	4	SP1N	---	BLK	PDP / HDP DECREASE (-)	W35	---	P127	---	18	BLK	LEFT WING LATCH (+)
W3	P1-7	4	P52	---	RED	WING WORKLIGHT RELAY (+)	W36	---	P101	---	16	RED	LEFT WING LATCH (+)
W4	P1-8	4	P51	---	BLK	WING WORKLIGHT RELAY (-)	W37	---	P102	---	16	BLK	LEFT WING LATCH (-)
W5	P1-16	2	SP2IN	---	WHI	PDP / HDP 12V SENSOR (ANALOG)	W38	---	P102	---	16	BLK	LEFT WING LATCH (-)
W6	P1-20	2	SP1N	---	GRN	PDP / HDP PTO SENSOR (12V PWR)	W39	---	P152	---	16	GRY	DRABRAH-HITCH SOLENOID (+)
W7	P1-20	2	SP1N	---	GRN	PDP / HDP PTO SENSOR (12V PWR)	W40	---	P152	---	16	GRY	DRABRAH-HITCH SOLENOID (+)
W8	P2-1	4	P12-1	---	RED	PDP INCREASE (+)	W41	---	P153	---	16	RED	FOLD (+)
W9	P2-2	4	P12-2	---	YEL	PDP INCREASE (+)	W42	---	P154	---	16	BLK	FOLD (-)
W10	P2-5	2	P42-2	---	GRN	LEFT VAC SENSOR (12V PWR)	W43	---	P125	---	18	WHI	PDP SENSOR (12V) (ANALOG)
W11	P2-6	2	P41-1	---	BLK	LEFT VAC SENSOR (12V PWR)	W44	---	P25	---	18	WHI	PDP SENSOR (12V) (ANALOG)
W12	P2-7	2	P41-2	---	BLK	LEFT VAC SENSOR (12V PWR)	W45	---	P24	---	18	BLK	PTO PRESSURE SENSOR (GND)
W13	P2-7	2	P41-2	---	BLK	LEFT VAC SENSOR (12V PWR)	W46	---	P24	---	18	BLK	PTO PRESSURE SENSOR (GND)
W14	P3-2	4	P72	---	BLK	LEFT VAC FAN SOLENOID (+)	W47	---	P126	---	18	BLK	PDP SENSOR (GND)
W15	P1-13	2	J51	---	GRN	PTO FLUID LVL SWITCH (DIGITAL)	W48	---	P126	---	16	VLT	PDP DECREASE (-)
W16	P1-14	2	J52	---	BLU	PTO HOT OIL SWITCH (DIGITAL)	W49	---	J29	---	26	VLT	HDP DECREASE (-)
W17	P1-15	2	J53	---	GRY	PTO PRESSURE SENSOR (ANALOG)	W50	---	J28	---	26	BRN	HDP DECREASE (-)
W18	J1-1	12	SP2IN	---	BLK	WING WORKLIGHT (-)	W51	---	P124	---	16	BRN	PDP DECREASE (-)
W19	J1-1	12	SP2IN	---	BLK	WING WORKLIGHT (+)	W52	---	P124	---	16	BRN	PDP DECREASE (-)
W20	SP1OUT	---	J55	---	BLK	PTO PRESSURE SENSOR (12V PWR)	W53	---	J67	---	26	BLK	WING CLOSING WHEEL SENSOR (12V) (GND)
W21	SP2OUT	---	J55	---	BLK	PTO PRESSURE SENSOR (12V PWR)	W54	---	J67	---	26	BLK	WING CLOSING WHEEL SENSOR (12V) (GND)
W22	SP2OUT	---	J22	---	BLK	RIGHT WING WORKLIGHT (-)	W55	---	J68	---	26	BLU	WING CLOSING WHEEL SENSOR (ANALOG)
W23	SP1OUT	---	J56	---	BLK	PTO COOLER (12V PWR)	W56	---	J69	---	26	BLK	WING CLOSING WHEEL INCREASE (+)
W24	SP2OUT	---	P112	---	RED	LEFT WING WORKLIGHT (+)	W57	---	J66	---	26	GRN	WING CLOSING WHEEL INCREASE (+)
W25	SP2OUT	---	P81	---	RED	LEFT WING WORKLIGHT (+)	W58	---	J66	---	26	GRN	WING CLOSING WHEEL INCREASE (+)
W26	J2-4	26	P82	---	RED	LEFT MARKER SOLENOID (+)	W59	---	J61	---	26	RED	CENTER CLOSING WHEEL SENSOR (12V) (PWR)
W27	J2-4	26	P82	---	RED	LEFT MARKER SOLENOID (+)	W60	---	J61	---	26	RED	CENTER CLOSING WHEEL SENSOR (12V) (GND)
W28	J3-1	12	J4A	---	RED	WHEEL SPEED #1 (PWR)	W61	---	J613	---	26	YEL	CENTER CLOSING WHEEL SENSOR (ANALOG)
W29	J3-2	12	J4B	---	BLK	WHEEL SPEED #1 (GND)	W62	---	J615	---	26	ORN	CENTER CLOSING WHEEL INCREASE (+)
W30	J3-3	12	J4C	---	WHI	WHEEL SPEED #1 (REQ)	W63	---	J616	---	26	BLK	CENTER CLOSING WHEEL INCREASE (+)
W31	J3-4	12	SP2IN	---	RED	LEFT WING LATCH (+)	W64	---	J617	---	26	BLK	CENTER CLOSING WHEEL INCREASE (+)
W32	J3-4	12	SP2IN	---	RED	LEFT WING LATCH (+)	W65	---	J618	---	26	BLK	CENTER CLOSING WHEEL INCREASE (+)
W33	SP1OUT	---	J26	---	BLK	HDP SENSOR (12V PWR)							

**BULK FILL SHUTOFF INTERCEPT HARNESS (P/N: 10963101)**

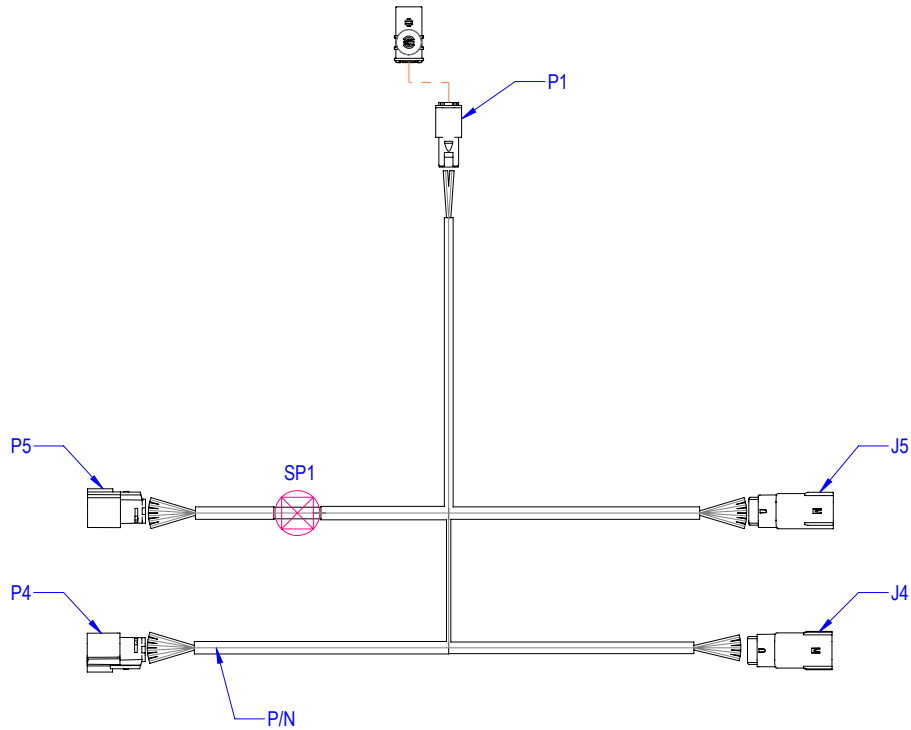

WIRE HOOKUP CHART								LABEL TABLE	
REF DES	FROM	USED W/	TO	USED W/	GAUGE	COLOR	FUNCTION	CONNECTOR	CONNECTOR LABEL
W1	P5:1	4	J5:1	6	18	WHT	PASSTROUGH	P1	BF SHUT-OFF
W2	P5:2	4	J5:2	6	18	WHT	PASSTROUGH		
W3	P5:5	4	SP1:IN	---	18	RED	BULK FILL FAN SHUT-OFF SWITCH (PWR) / PASSTROUGH	P4	BF IPN J4
W4	SP1:OUT	---	J5:5	6	18	RED	PASSTROUGH		
W5	SP1:OUT	---	P1:1	1	18	RED	BULK FILL FAN SHUT-OFF SWITCH (PWR)	P5	BF IPN J5
W6	P5:6	4	J5:6	6	18	WHT	PASSTROUGH		
W7	P5:7	4	J5:7	6	18	WHT	PASSTROUGH	J4	TO BF HARNESS
W8	P5:8	4	J5:8	6	18	WHT	PASSTROUGH		
W9	P4:1	4	J4:1	6	18	WHT	PASSTROUGH	J5	TO BF HARNESS
W10	P4:2	4	J4:2	6	18	WHT	PASSTROUGH		
W11	P4:5	4	J4:5	6	18	WHT	PASSTROUGH	P/N	PART NUMBER REV / DATE VENDOR I.D.
W12	P4:6	4	J4:6	6	18	WHT	PASSTROUGH		
W13	P4:7	4	P1:2	1	18	BLU	BULK FILL FAN SHUT OFF SWITCH (GND)		
W14	P4:8	4	J4:8	6	18	WHT	PASSTROUGH		



**TAIL LIGHT EXTENSION HARNESS (P/N: A26631)**



WIRE HOOKUP CHART							
REF DES	FROM	USED W/	TO	USED W/	GAUGE	COLOR	FUNCTION
W1	J1-1	3	P1-1	3	16	WHT	GND
W2	J1-3	3	P1-3	3	16	YEL	LH TURN
W3	J1-5	3	P1-5	3	16	GRN	RH TURN
W4	J1-6	3	P1-6	3	16	BRN	TAIL

**TAIL LIGHT HARNESS (P/N: A27151)**



WIRE HOOKUP CHART							
REF DES	FROM	USED W/	TO	USED W/	GAUGE	COLOR	FUNCTION
W1	J1-1	3	P1-1	3	16	WHT	GND
W2	J1-3	3	P1-3	3	16	YEL	LH TURN
W3	J1-5	3	P1-5	3	16	GRN	RH TURN
W4	J1-6	3	P1-6	3	16	BRN	TAIL

ROW UNIT POWER HARNESS, 24 ROW 20"- ROWS 1-12 (P/N: A26572)

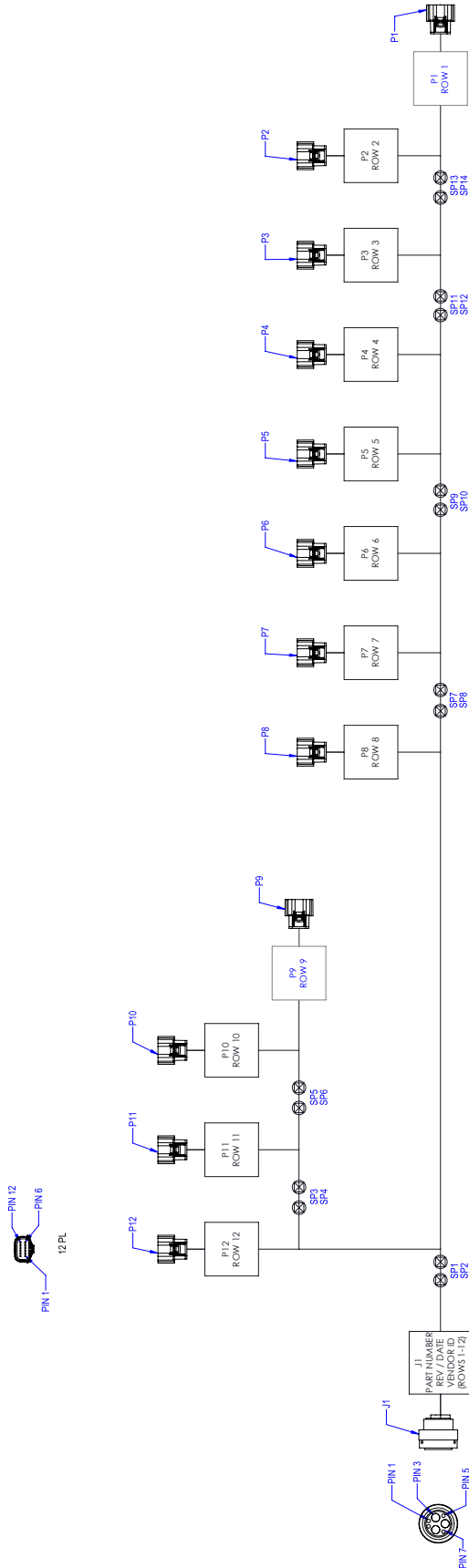

WIRE HOOKUP CHART

REF DES	FROM	LISTED W/	TO	USED W/	FROM	USED W/	TO	LISTED W/	GALGE	COLOR	FUNCTION
W1	J1-6	5	SP1	---	W32	SP8	P8-4	3	18	BLK	RU 8 (GND)
W2	J1-4	5	SP2	---	W33	SP8	P7-2	3	18	BLK	RU 7 (GND)
W3	SP1	---	SP3	---	W34	SP8	P7-4	3	18	BLK	RU 7 (GND)
W4	SP1	---	---	---	W35	SP9	---	---	10	RED	PWR
W5	SP2	---	SP4	---	W36	SP9	P6-1	3	18	RED	RU 6 (PWR)
W6	SP2	---	---	---	W37	SP9	P6-3	3	18	RED	RU 6 (PWR)
W7	SP3	---	SP5	---	W38	SP9	P5-1	3	18	RED	RU 5 (PWR)
W8	SP3	---	---	---	W39	SP9	P5-3	3	18	RED	RU 5 (PWR)
W9	SP3	---	P12-1	3	W40	SP10	---	---	10	BLK	GND
W10	SP3	---	P12-3	3	W41	SP10	P5-2	3	18	BLK	RU 6 (GND)
W11	SP3	---	P11-1	3	W42	SP10	P5-4	3	18	BLK	RU 6 (GND)
W12	SP4	---	P11-3	3	W43	SP10	P5-2	3	18	BLK	RU 5 (GND)
W13	SP4	---	SP6	---	W44	SP10	P5-4	3	18	BLK	RU 5 (GND)
W14	SP4	---	P12-2	3	W45	SP11	---	---	14	RED	PWR
W15	SP4	---	P11-2	3	W46	SP11	P4-1	3	18	RED	RU 4 (PWR)
W16	SP4	---	P11-4	3	W47	SP11	P4-3	3	18	RED	RU 4 (PWR)
W17	SP5	---	P10-1	3	W48	SP11	P3-1	3	18	RED	RU 3 (PWR)
W18	SP5	---	P10-3	3	W49	SP11	P3-3	3	18	RED	RU 3 (PWR)
W19	SP5	---	P9-1	3	W50	SP12	---	---	14	BLK	GND
W20	SP5	---	P9-3	3	W51	SP12	P4-2	3	18	BLK	RU 4 (GND)
W21	SP6	---	P10-2	3	W52	SP12	P4-4	3	18	BLK	RU 4 (GND)
W22	SP6	---	P10-4	3	W53	SP12	P3-2	3	18	BLK	RU 3 (GND)
W23	SP6	---	P9-2	3	W54	SP12	P3-4	3	18	BLK	RU 3 (GND)
W24	SP6	---	P9-4	3	W55	SP13	P3-1	3	18	RED	RU 2 (PWR)
W25	SP7	---	SP9	---	W56	SP13	P2-3	3	18	RED	RU 2 (PWR)
W26	SP7	---	P8-1	3	W57	SP13	P1-1	3	18	RED	RU 1 (PWR)
W27	SP7	---	P8-3	3	W58	SP13	P1-3	3	18	RED	RU 1 (PWR)
W28	SP7	---	P7-1	3	W59	SP14	P2-2	3	18	BLK	RU 2 (GND)
W29	SP7	---	P7-3	3	W60	SP14	P2-4	3	18	BLK	RU 2 (GND)
W30	SP8	---	SP10	---	W61	SP14	P1-2	3	18	BLK	RU 1 (GND)
W31	SP8	---	P8-2	3	W62	SP14	P1-4	3	18	BLK	RU 1 (GND)

STRAPPING TABLE											
CONNECTOR	PIN 5	PIN 6	PIN 7	PIN 8	PIN 9	PIN 10	PIN 11	PIN 12	ROW #		
P1	GND	---	---	---	---	---	---	GND	1		
P2	---	GND	---	---	---	---	---	GND	2		
P3	GND	GND	---	---	---	---	---	GND	3		
P4	---	---	GND	---	---	---	---	GND	4		
P5	GND	---	---	GND	---	---	---	GND	5		
P6	---	GND	GND	---	---	---	---	GND	6		
P7	GND	GND	GND	---	---	---	---	GND	7		
P8	---	---	---	GND	---	---	---	GND	8		
P9	GND	---	---	GND	---	---	---	GND	9		
P10	---	GND	---	GND	---	---	---	GND	10		
P11	GND	GND	---	GND	---	---	---	GND	11		
P12	---	---	GND	GND	---	---	---	GND	12		

ROW UNIT POWER HARNESS, 24 ROW 20"- ROWS 13-24 (P/N: A26571)

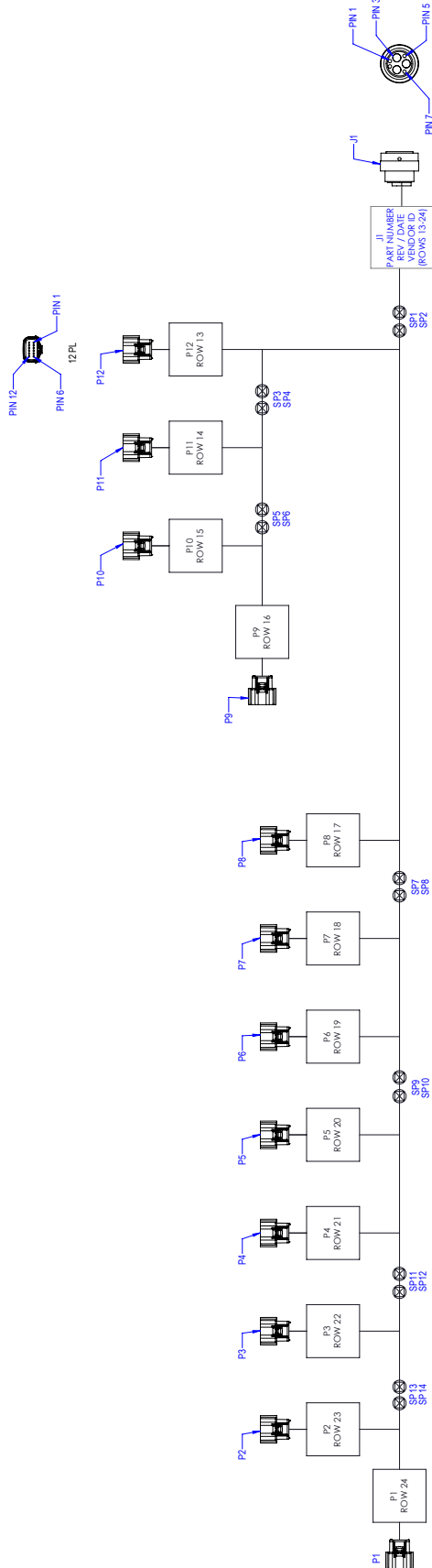

WIRE-HOOKUP CHART

REF ID	FRM	USED W	TO	USED W	GAUGE	COLOR	FUNCTION	REF ID	USED W	TO	USED W	GAUGE	COLOR	FUNCTION		
W1	J16	5	SP1	---	4	RED	PWR	W02	SP8	---	P6.4	3	18	BLK	RU8 (GND)	
W2	J14	5	SP2	---	4	BLK	GRN	W03	SP8	---	P7.2	3	18	BLK	RU7 (GND)	
W3	SP1	---	SP1	---	16	RED	PWR	W04	SP8	---	P7.4	3	18	BLK	RU7 (GND)	
W4	SP1	---	SP1	---	8	RED	PWR	W05	SP9	---	SP11	---	10	RED	PWR	
W5	SP2	---	SP4	---	16	BLK	GND	W06	SP9	---	P6.1	3	18	RED	RU6 (PWR)	
W6	SP2	---	SP8	---	8	BLK	GND	W07	SP9	---	P6.3	3	18	RED	RU6 (PWR)	
W7	SP3	---	SP8	---	16	RED	PWR	W08	SP9	---	P5.1	3	18	RED	RU5 (PWR)	
W8	SP3	---	P12.1	3	18	RED	RU12 (PWR)	W09	SP9	---	P5.3	3	18	RED	RU5 (PWR)	
W9	SP3	---	P12.3	3	18	RED	RU12 (PWR)	W10	SP10	---	SP12	---	10	BLK	GND	
W10	SP3	---	P11.1	3	18	RED	RU11 (PWR)	W11	SP10	---	P6.2	3	18	BLK	RU6 (GND)	
W11	SP3	---	P11.3	3	18	RED	RU11 (PWR)	W12	SP10	---	P6.4	3	18	BLK	RU6 (GND)	
W12	SP4	---	SP8	---	16	BLK	GND	W13	SP10	---	P5.2	3	18	BLK	RU5 (GND)	
W13	SP4	---	P12.2	3	18	BLK	RU12 (GND)	W14	SP10	---	P5.4	3	18	BLK	RU5 (GND)	
W14	SP4	---	P12.4	3	18	BLK	RU12 (GND)	W15	SP11	---	SP13	---	14	RED	PWR	
W15	SP4	---	P11.2	3	18	BLK	RU11 (GND)	W16	SP11	---	P4.1	3	18	RED	RU1 (PWR)	
W16	SP4	---	P11.4	3	18	BLK	RU11 (GND)	W17	SP11	---	P4.3	3	18	RED	RU1 (PWR)	
W17	SP5	---	P10.1	3	18	RED	RU10 (PWR)	W18	SP11	---	P5.1	3	18	RED	RU3 (PWR)	
W18	SP5	---	P10.3	3	18	RED	RU10 (PWR)	W19	SP11	---	P5.3	3	18	RED	RU3 (PWR)	
W19	SP5	---	SP1	---	3	18	RED	RU1 (PWR)	W20	SP12	---	SP14	---	14	BLK	GND
W20	SP5	---	SP3	---	3	18	RED	RU3 (PWR)	W21	SP12	---	P4.2	3	18	BLK	RU4 (GND)
W21	SP5	---	P10.2	3	18	BLK	RU10 (GND)	W22	SP12	---	P4.4	3	18	BLK	RU4 (GND)	
W22	SP5	---	P10.4	3	18	BLK	RU10 (GND)	W23	SP12	---	P3.2	3	18	BLK	RU3 (GND)	
W23	SP5	---	P9.2	3	18	BLK	RU9 (GND)	W24	SP12	---	P3.4	3	18	BLK	RU3 (GND)	
W24	SP5	---	SP4	---	3	18	BLK	RU4 (GND)	W25	SP13	---	P2.1	3	18	RED	RU2 (PWR)
W25	SP7	---	SP4	---	10	RED	PWR	W26	SP13	---	P2.3	3	18	RED	RU2 (PWR)	
W26	SP7	---	SP8	---	3	18	RED	RU8 (PWR)	W27	SP13	---	P1.1	3	18	RED	RU1 (PWR)
W27	SP7	---	P8.3	3	18	RED	RU8 (PWR)	W28	SP13	---	P1.3	3	18	RED	RU1 (PWR)	
W28	SP7	---	P7.1	3	18	RED	RU7 (PWR)	W29	SP14	---	P2.2	3	18	BLK	RU2 (GND)	
W29	SP7	---	P7.3	3	18	RED	RU7 (PWR)	W30	SP14	---	P2.4	3	18	BLK	RU2 (GND)	
W30	SP8	---	SP10	---	10	BLK	GND	W31	SP14	---	P1.2	3	18	BLK	RU1 (GND)	
W31	SP8	---	P8.2	3	18	BLK	RU8 (GND)	W32	SP14	---	P1.4	3	18	BLK	RU1 (GND)	

SHIPPING TABLE

CONNECTOR	PN 5	PN 6	PN 7	PN 8	PN 9	PN 10	PN 11	PN 12	ROW#
P1	GND	GND	GND	GND	GND	GND	GND	GND	24
P2	GND	GND	GND	GND	GND	GND	GND	GND	23
P3	GND	GND	GND	GND	GND	GND	GND	GND	22
P4	GND	GND	GND	GND	GND	GND	GND	GND	21
P5	GND	GND	GND	GND	GND	GND	GND	GND	20
P6	GND	GND	GND	GND	GND	GND	GND	GND	19
P7	GND	GND	GND	GND	GND	GND	GND	GND	18
P8	GND	GND	GND	GND	GND	GND	GND	GND	17
P9	GND	GND	GND	GND	GND	GND	GND	GND	16
P10	GND	GND	GND	GND	GND	GND	GND	GND	15
P11	GND	GND	GND	GND	GND	GND	GND	GND	14
P12	GND	GND	GND	GND	GND	GND	GND	GND	13

**DRAWBAR HITCH HARNESS, 24 ROW 20" (P/N: A26628)**

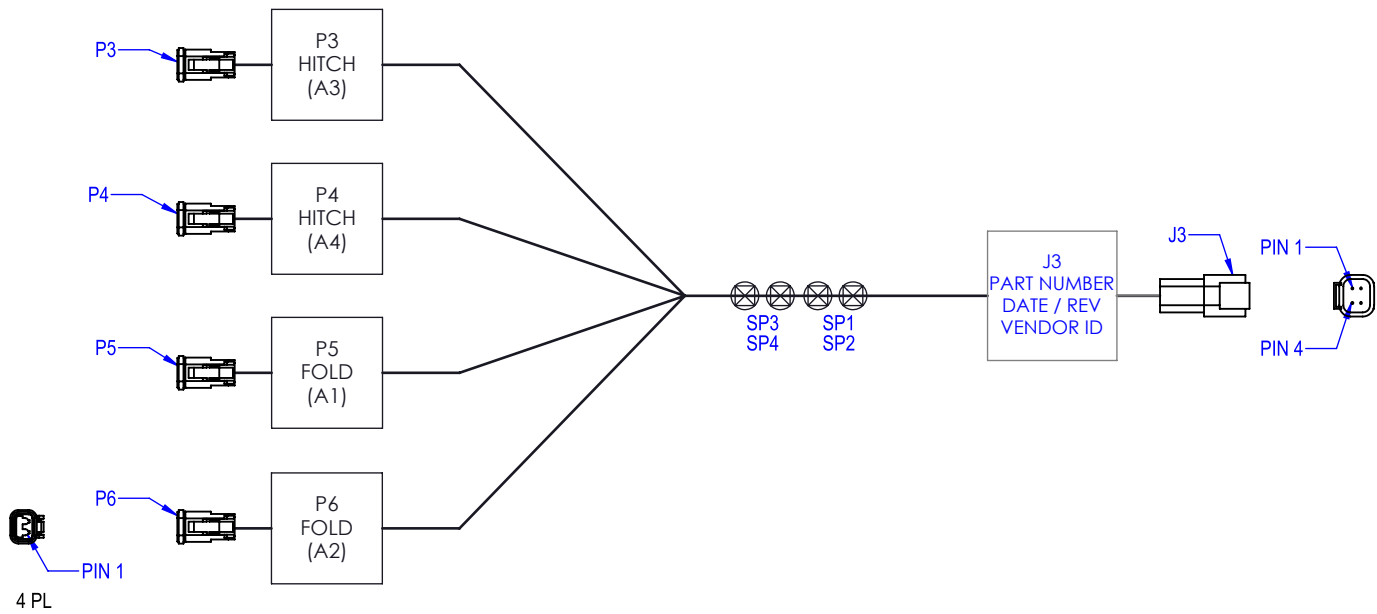

WIRE HOOKUP CHART							
REF DES	FORM	USED W/	TO	USED W/	GAUGE	COLOR	FUNCTION
W1	J3-1	4	SP1	---	16	WHT	DRAWBAR HITCH SOLENOID (+)
W2	J3-2	4	SP2	---	16	GRN	DRAWBAR HITCH SOLENOID (-)
W3	J3-3	4	SP3	---	16	RED	WING FOLD SOLENOID (+)
W4	J3-4	4	SP4	---	16	BLK	WING FOLD SOLENOID (-)
W5	SP1	---	P3-1	6	16	WHT	DRAWBAR HITCH SOLENOID (+)
W6	SP1	---	P4-1	6	16	WHT	DRAWBAR HITCH SOLENOID (+)
W7	SP2	---	P3-2	6	16	GRN	DRAWBAR HITCH SOLENOID (-)
W8	SP2	---	P4-2	6	16	GRN	DRAWBAR HITCH SOLENOID (-)
W9	SP3	---	P5-1	6	16	RED	WING FOLD SOLENOID (+)
W10	SP3	---	P6-1	6	16	RED	WING FOLD SOLENOID (+)
W11	SP4	---	P5-2	6	16	BLK	WING FOLD SOLENOID (-)
W12	SP4	---	P6-2	6	16	BLK	WING FOLD SOLENOID (-)

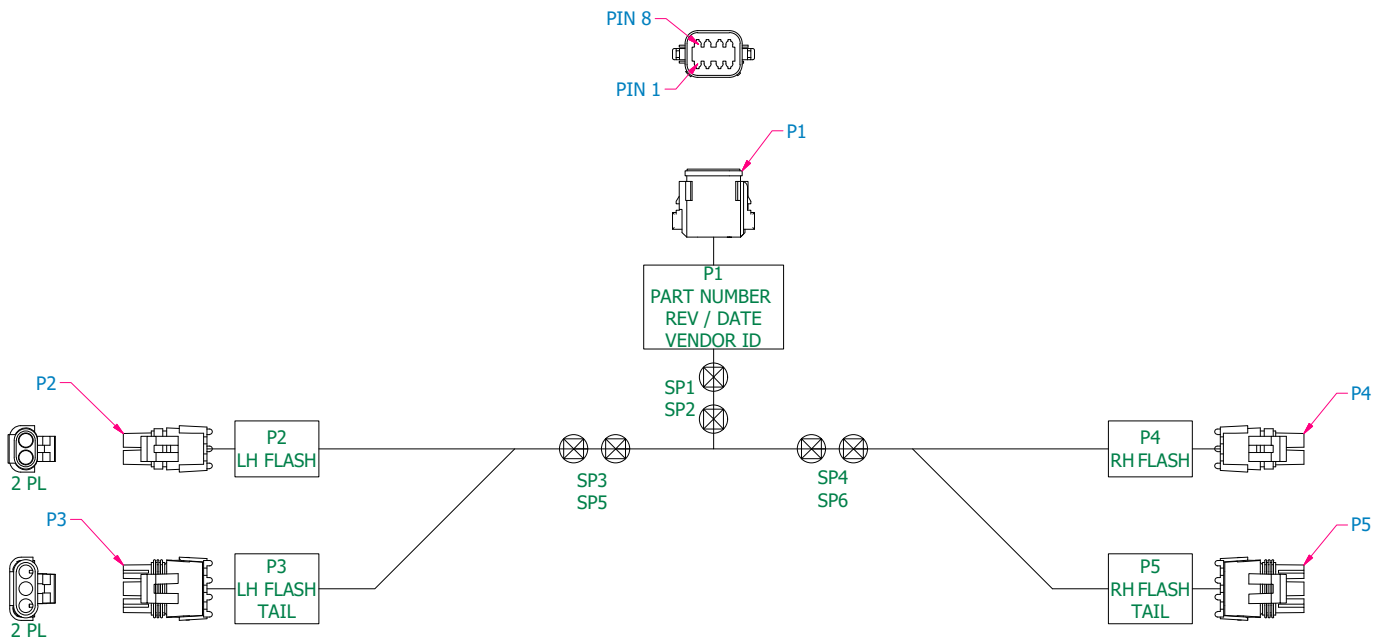

**DRAWBAR HITCH HARNESS, 24 ROW 20" (P/N: A26628)**



WIRE HOOKUP CHART

REF DES	FROM	USED WITH ITEM	TO	USED WITH ITEM	GAUGE	COLOR	FUNCTION
W1	P1-1	4	SP1	---	18	WHT	GND
W2	P1-6	4	SP2	---	18	BRN	TAIL
W3	SP1	---	SP3	---	18	WHT	GND
W4	SP1	---	SP4	---	18	WHT	GND
W5	SP2	---	P3-C	5	18	BRN	TAIL
W6	SP2	---	P5-C	5	18	BRN	TAIL
W7	P1-3	4	SP5	---	18	YEL	LH TURN
W9	P1-5	4	SP6	---	18	GRN	RH TURN
W8	SP3	---	P2-A	5	18	WHT	GND
W10	SP3	---	P3-A	5	18	WHT	GND
W11	SP4	---	P4-A	5	18	WHT	GND
W11	SP4	---	P5-A	5	18	WHT	GND
W12	SP5	---	P2-B	5	18	YEL	LH TURN
W13	SP5	---	P3-B	5	18	YEL	LH TURN
W14	SP6	---	P4-B	5	18	GRN	RH TURN
W15	SP6	---	P5-B	5	18	GRN	RH TURN

## HYDRAULIC HOSE LIFE

 <b>WARNING</b>	<p>Pressurized hydraulic fluid can penetrate body tissue and result in death, serious infection, or other injuries. Fluid injected under skin must be <b>IMMEDIATELY</b> removed by a surgeon familiar with this type of injury. Make sure connections are tight and hoses and fittings are not damaged before applying system pressure. Leaks can be invisible. Keep away from suspected leaks. Relieve pressure before searching for leaks or performing any system maintenance.</p>
	

Proper storage of hydraulic hoses can significantly increase the life of the hoses, for a period of three to five years. After this period, service life of hoses may decrease, depending on variables such as variances in rubber materials and storage environment. Refer to the guidelines below for best practices when storing.

- Store in a clean, cool and dry area
- Avoid direct sunlight or moisture
- Do not store near high power electrical equipment
- Avoid contact with corrosive chemicals
- Avoid ultraviolet light
- Avoid areas with obvious signs of insects or rodents

Unusually long periods of storage or poor storage environment may lead to performance issues or premature failure. Always inspect all hoses prior to use for extensive wear, cuts, or holes. If such flaws are identified, replace immediately to avoid potential failure, property damage or bodily injury.

**BULK FILL**

PROBLEM	POSSIBLE CAUSE	SOLUTION
Seed does not travel through delivery tubes.	System pressure set too low.	Increase system pressure.
Seed stops flowing to row unit during planting.	Seed surging.	Shut down air seed delivery system and restart system from idle; seed should start flowing.
	Debris in system.	Insert shutoff door, open cleanout door. remove plug.
Seed does not move from entrainer at startup after exposure to water.	Seed swelled in entrainer.	Insert shutoff door, open cleanout door. remove swelled seed.
Seed bridging in entrainer.	System pressure too high.	Decrease system pressure to recommended pressures: <ul style="list-style-type: none"> <li>• Corn - 12" (30 cm) of water</li> <li>• Soybean - 10" (25 cm) of water</li> </ul> <p><b>NOTE: Actual pressure needed is affected by seed size, shape and coating.</b></p>

**AIR CLOSING WHEELS**

PROBLEM	POSSIBLE CAUSE	SOLUTION
Closing wheel(s) leave severe imprint in soil.	Too much closing wheel down pressure.	Adjust closing wheel pressure.
Closing wheel(s) not firming soil around seed.	Not enough closing wheel down pressure.	Adjust closing wheel pressure. Severe no till conditions may require use of cast iron closing wheels.
"V" closing wheel running on top of seed furrow.	Improper centering.	Align. See <a href="#">"Closing Wheel General Adjustments" on page 3-1</a>
Single closing wheel not directly over seed.	Improper centering.	Align. See <a href="#">"Closing Wheel General Adjustments" on page 3-1</a>
Folded air bag.	Initial inflation with planter on ground.	Inflate system to a lower pressure and manually straighten out airbags.
System unable to maintain pressure.	Loose fitting(s) or bad compressor.	Verify compressor is running.
		Verify tank pressure.
		Check for air leaks.
System is building pressure but individual circuits are not pressuizing (tank pressure is good, circuit pressure gauge is zero).	Loose fitting(s) or bad solenoid.	Verify pressure in circuit gauges at control valves.
		Check circuit for air leaks.
		Verify air control valve solenoids are functioning.

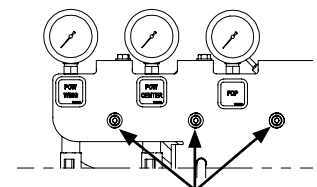

Push solenoid button(s) to manually operate.

**ROW MARKER OPERATION**

<b>PROBLEM</b>	<b>POSSIBLE CAUSE</b>	<b>SOLUTION</b>
Right marker lowering slower than left marker.	Solenoid valve cartridge in port B4 of R.H. block not opening completely.	Switch with cartridge in port B4 of L.H. block. If problem repeats, replace cartridge.
	Hose pinched or collapsed.	Inspect hose routing. Replace or repair hoses as required.
Left marker lowering slower than right marker.	Solenoid valve cartridge in port B4 of L.H. block not opening completely.	Switch with cartridge in port B4 of R.H block. If problem repeats, replace cartridge.
	Hose pinched or collapsed.	Inspect hose routing. Replace or repair hoses as required.
Both markers lowering.	Solenoid valve cartridge stuck open. If left marker switch is selected, right cartridge (B4) is defective. If right marker switch is selected, left cartridge (B4) is defective.	Replace solenoid valve cartridge.
Neither marker lowers.	Coils at B4 not energized.	Poor ground on wire, bad wire connection or damaged wire. Repair as required.
	Marker flow control valve closed too far.	See <a href="#">“Row Marker Speed Adjustment” on page 2-19</a>
Neither marker will raise.	Marker flow control valve closed too far.	See <a href="#">“Row Marker Speed Adjustment” on page 2-19</a>
Right marker will not lower.	Solenoid coil in port B4 of R.H. block not energized.	Check switch on control console. Replace if defective. Check coil ground wire. Check for poor connection or damaged wire.
	Solenoid cartridge in port B4 of R.H. block stuck closed.	Switch cartridge with one on the planter you know is operating properly. If right marker lowers, replace defective cartridge.
Left marker will not lower.	Solenoid coil in port B4 of L.H. block not energized.	Check switch on control console. Replace if defective. Check coil ground wire. Check for poor connection or damaged wire.
	Solenoid cartridge in port B4 of L.H. block stuck closed.	Switch cartridge with one on the planter you know is operating properly. If left marker lowers, replace defective cartridge.
Markers traveling too fast and damaging rubber stop on transport stands and/or damaging pivot at rod end of marker cylinders.	Adjust row marker flow control valve.	See <a href="#">“Row Marker Speed Adjustment” on page 2-19</a>



**TRUE RATE SEED METER**

<b>PROBLEM</b>	<b>POSSIBLE CAUSE</b>	<b>SOLUTION</b>
Low seed count.	Meter RPM too high.	Reduce planting rate or planting speed.
	Singulator blade setting too aggressive.	Adjust singulator blade.
	Vacuum level too low.	Increase fan speed.
	Seed sensor not picking up all seeds dropped.	Clean seed tube. Move meter to different row.
	Seeds sticking to seed disc.	Use graphite or talc to aid release.
	Seed treatment buildup in seed disc recesses.	Reduce amount of treatment used and or mix thoroughly. Add talc.
	Seed size too large for disc used.	Use appropriate disc for seed size.
	Wrong seed disc.	Use appropriate disc for seed type and size.
	Failed/worn drive components.	Inspect and replace parts as required.
	Plugged orifices in seed disc.	Inspect and clean disc. Check remnant ejector.
	Loss of vacuum at meter.	Check for foreign material between vacuum cover and disc. Inspect parts for wear/damage. Clean or replace as required.
	Seed bridging in hopper.	Add graphite to improve seed flow.
	Faulty vacuum gauge reading.	Repair/replace gauge.
	Dirt in vacuum manifold.	Check vacuum manifold for dirt and clean.
	Seed baffle (If applicable) not allowing seed flow due to bridging of seed.	Mix talc thoroughly to coat all seeds. Remove seed baffle. See Row Unit Operation section.
	Seed disc worn.	Replace.
	Vacuum seal worn.	Replace.
Not planting seed.	Seed hoppers empty.	Fill seed hopper.
	Seed tube plugged/damaged.	Clean or replace tube.
	Meter drive damaged.	Repair/replace drive components.
	Low/no vacuum.	Inspect vacuum system and repair as necessary.
	Singulator blade setting too aggressive.	Adjust singulator blade.
	Faulty vacuum gauge.	Repair/replace vacuum gauge.
	Seed bridging in hopper.	Add graphite to improve seed flow.
	Loss of vacuum at meter.	Check for foreign material between vacuum cover and disc. Inspect parts for wear/ damage. Clean and/ or replace as required.
	Wrong seed disc.	Use appropriate disc for seed type and size.
	Fan not running.	Start fan.
	Dirt in vacuum manifold.	Check vacuum manifold for dirt and clean.

Continued on next page.

**TRUE RATE SEED METER - Continued**

<b>PROBLEM</b>	<b>POSSIBLE CAUSE</b>	<b>SOLUTION</b>
Not planting seed. (Continued)	Seed baffle (if applicable) not allowing seed flow due to bridging of seed.	Mix talc thoroughly to coat all seeds. Remove seed baffle. Row Unit Operation section.
	High vacuum.	Adjust vacuum level to appropriate level.
	Wrong seed disc.	Replace seed disc.
	Singulator setting not aggressive enough.	Adjust singulator.
Poor seed spacing.	Faulty vacuum gauge.	Check gauge line for dirt/obstruction. Repair/replace vacuum gauge.
	Obstruction in seed tube.	Clean seed tube.
	Dirty/damaged seed disc.	Inspect seed disc for damage, foreign material in orifices or seed treatment buildup in recesses. Clean or replace.
	Wrong vacuum setting.	Adjust vacuum to appropriate level.
	Excess foreign material in seed.	Inspect and clean meter and seed discs. Use clean, undamaged seed.
	Incorrect singulator setting.	Adjust singulator to appropriate setting.
	Inconsistent driveline.	Inspect drive components for rust, misalignment, worn or damaged parts. Replace/repair as required.
	Toolbar not level or wrong height.	Adjust hitch to level toolbar and row units.
	Planting too fast for conditions.	Reduce speed.
Rough field conditions.	Reduce speed.	
Irregular seed population.	Driving too fast.	Reduce speed.
Unable to achieve desired vacuum level.	Tractor hydraulic flow set too low.	Increase flow to fan motor.
	Incorrect hydraulic connections.	Check all hydraulic connections and hose routings.
	Damaged fan components.	Inspect motor and impeller for wear/damage and repair/replace as necessary.
	Vacuum hose pinched/kinked/blocked.	Inspect air lines for any damage or obstruction. Clean air lines and manifold by removing end cap from manifold and running fan at high speed.
	Vacuum hose loose/disconnected.	Inspect and reattach all air hoses.
	Tractor not producing required hydraulic flow/pressure.	Have tractor serviced by qualified technician.
	Dirt in vacuum gauge line.	Check gauge line for dirt/obstruction and clean.

**SOLENOID VALVE**

<b>PROBLEM</b>	<b>POSSIBLE CAUSE</b>	<b>SOLUTION</b>
No solenoids operate.	Low voltage.	Must be connected to 12 volt DC only. Negative ground.
	Blown fuse.	Replace control console fuse with AGC-15 amp.
	Battery connection.	Clean and tighten.
	Wiring harness damaged.	Repair or replace.
One solenoid valve will not operate.	Bad switch.	Replace on control panel.
	Cut wire in harness.	Locate and repair.
	Bad coil.	Replace.
	Poor connection at coil.	Check.
Valve operating when not energized.	Valve stem stuck open.	Replace cartridge.
	O-ring leaking.	Install new O-ring kit.
	Foreign material under poppet.	Remove and clean cartridge.

**PTO PUMP DRIVE AND OIL COOLER OPTION**

<b>PROBLEM</b>	<b>POSSIBLE CAUSE</b>	<b>SOLUTION</b>
Pump is squealing.	Lack of oil to pump.	Check for plugged suction strainer. Check oil level.
Oil temperature high.	Low oil level.	Check oil level and add as required.
Desired fan speed cannot be achieved.	Low oil level.	Check oil level and add as required.
	Plugged filter.	Check and change as required.

**This page intentionally left blank.**