

MODEL 4805 70CM EXPORT FRONT FOLDING PLANTER OPERATOR'S MANUAL

M0314-01

Rev. 11/21

This manual is applicable to: Model 4805 70CM 24R Front Folding Planters

Record the model number and serial number of your planter along with date purchased:

Model Number _____ 4805 _____

Serial Number _____

Date Purchased _____

Monitor Serial Number _____
Measured Pulses Per km (Radar Distance Sensor) _____
Measured Pulses Per km (Magnetic Distance Sensor) _____

SERIAL NUMBER

The serial number plate is located on the planter frame as shown below. The serial number provides important information about your planter and is needed to obtain correct replacement parts. Always provide model number and serial number to your Kinze Dealer when ordering parts or when contacting Kinze Manufacturing, Inc.



Serial Number Plate Location



EUROPEAN DECLARATION OF CONFORMITY

Kinze Manufacturing
2172 M Avenue
Williamsburg, IA 53261

Kinze Europe UAB
Guopstu k., Senuju Traku sen
LT-21148 Traku r., Lithuania

We, Kinze Manufacturing and Kinze Europe UAB declare, under our sole responsibility, the following products – agricultural planter models 3005, 3035, 3115, 3145, 3205, 3505, 3605, 3665, 3705, 4805, and 4905 – to which this declaration relates, are in conformity with the applicable provisions of the following standards, other normative documents and Directives, as appropriate by version and model:

2006/42/EC; EN 1037:1995+A1:2008; EN ISO 13850:2008; EN ISO 13857:2008; EN 349:1993+A1:2008; EN 547-1:1996+A1:2008; EN 547-2:1996+A1:2008; EN 547-3:1996+A1:2008; EN ISO 13732-1:2008; EN 614-1:2006+A1:2009; EN 614-2:2000+A1:2008; EN 953:1997+A1:2009; EN ISO 13849-1:2008; EN ISO 13849-2:2012; EN ISO 4254-1; EN ISO 12100:2010; EN ISO 4413:2010.

The Technical Construction File is maintained at: Kinze Manufacturing, Inc., 2172 M Avenue, Williamsburg, Iowa, USA, 52361-0806.

The authorized representative located within the community is: Edvardas Melys, Kinze Europe UAB, Guopstu k., Senuju Traku sen, LT-21148 Traku r., Lithuania.

Place of Issue: Kinze Manufacturing Inc., Williamsburg, Iowa, USA.

Date of Issue: 20200821 | August 21, 2020

Signed on behalf of Kinze Manufacturing Inc. and Kinze Europe UAB:

Jay D. Grimes

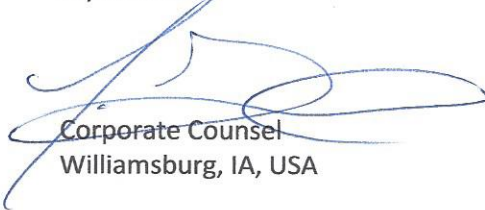

Corporate Counsel
Williamsburg, IA, USA



Kinze Manufacturing, Inc.



СЕРТИФИКАТ СООТВЕТСТВИЯ

№ ЕАЭС RU C-US.АД07.В.02342/20

Серия **RU** № **0225035**

ОРГАН ПО СЕРТИФИКАЦИИ Орган по сертификации Общество с ограниченной ответственностью «Центр Сертификации «ВЕЛЕС». Место нахождения (адрес юридического лица): 195009, РОССИЯ, город Санкт-Петербург, улица Академика Лебедева, дом 12, корпус 2, литера А, этаж 2, комната 26. Адрес места осуществления деятельности: 190068, РОССИЯ, город Санкт-Петербург, переулок Никольский, дом 4 литер А, помещение 8Н. Уникальный номер записи об аккредитации в реестре аккредитованных лиц № RA.RU.10АД07. Дата решения об аккредитации: 24.03.2016. Телефон: +74952211810 Адрес электронной почты: info@velessert.ru

ЗАЯВИТЕЛЬ ОБЩЕСТВО С ОГРАНИЧЕННОЙ ОТВЕТСТВЕННОСТЬЮ "МИР ТЕХНОЛОГИЙ"
Место нахождения (адрес юридического лица) и адрес места осуществления деятельности: 117042, Россия, город Москва, улица Адмирала Руднева, дом 4, этаж 6, помещение IV, офис 613
Основной государственный регистрационный номер 1187746469096.
Телефон: 89154152183. Адрес электронной почты: MirTekhnology@gmail.com

ИЗГОТОВИТЕЛЬ KINZE Manufacturing, Inc.
Место нахождения (адрес юридического лица): Соединенные Штаты, 2172 M Avenue, Williamsburg, IA 52631-0806
Филиал изготовителя: KINZE Europe, UAB Литва, Guopstu kelias 17, Guopstos, LT-21148 Traku rajonas

ПРОДУКЦИЯ Машины сельскохозяйственные: сеялка точного высева торговой марки KINZE, моделей: 3000, 3005, 3030, 3035, 3110, 3115, 3140, 3145, 3200, 3205, 3500, 3505, 3600, 3605, 3660, 3665, 3700, 3705, 4700, 4705, 4800, 4805, 4900, 4905.
Продукция изготовлена в соответствии с Директивой 2006/42/ЕС «Машины и механизмы».

Серийный выпуск

КОД ТН ВЭД ЕАЭС 8432311100

СООТВЕТСТВУЕТ ТРЕБОВАНИЯМ

Технического регламента Таможенного союза "О безопасности машин и оборудования" (ТР ТС 010/2011)

СЕРТИФИКАТ СООТВЕТСТВИЯ ВЫДАН НА ОСНОВАНИИ протокола испытаний № 1023/3АТС-2020 от 27.10.2020 года, выданного Испытательной лабораторией «АвтоТракторные Средства» Общество с ограниченной ответственностью «ПРОММАШ ТЕСТ» (регистрационный номер аттестата аккредитации RA.RU.21НА71) акта анализа состояния производства от 21.09.2020 года, выданного Органом по сертификации Общество с ограниченной ответственностью «Центр Сертификации «ВЕЛЕС» обоснования безопасности; руководства по эксплуатации; паспорта

Схема сертификации: 1с

ДОПОЛНИТЕЛЬНАЯ ИНФОРМАЦИЯ ГОСТ Р 53489-2009 "Система стандартов безопасности труда. Машины сельскохозяйственные навесные и прицепные. Общие требования безопасности" разделы 4 и 5. Срок службы, срок и условия хранения указаны в эксплуатационной документации, приложенной к изделию.

СРОК ДЕЙСТВИЯ С 28.10.2020 **ПО** 27.10.2025
ВКЛЮЧИТЕЛЬНО

Руководитель (уполномоченное
лицо) органа по сертификации

Эксперт (эксперт-аудитор)
(эксперты (эксперты-аудиторы))

Родзиков Галина Александровна (Ф.И.О.)
Киреевко Константин Борисович (Ф.И.О.)



This page intentionally left blank.

TO THE DEALER

Predelivery service includes assembly, lubrication, adjustment and test. This service helps ensure planter is delivered to retail customer/end user ready for field use.

PREDELIVERY CHECKLIST

Use the following checklist after planter is completely assembled. Check off each item as it is found satisfactory or after proper adjustment is made.

- Row units properly spaced and optional attachments correctly assembled.
- Row marker assemblies installed and adjusted at each end of the planter.
- Vacuum meter and bulk fill components properly installed (as applicable).
- All grease fittings in place and lubricated.
- All working parts move freely, bolts are tight, and cotter pins are spread.
- Check all drive chains for proper tension and alignment.
- Check for oil leaks and proper hydraulic operation.
- Hydraulic hoses correctly routed to prevent damage.
- Inflate tires to specified air pressure and torque wheel lug bolts and lug nuts as specified in the Operator Manual.
- All safety decals correctly located and legible. Replace if damaged.
- All reflective decals and SMV sign correctly located and visible when the planter is in transport position.
- Safety/warning lights correctly installed and working properly.
- Paint all parts scratched during shipment or assembly.
- All safety lockup devices on the planter and correctly located.
- Auxiliary safety chain properly installed and hardware torqued to specification.
- Vacuum fan PTO-driven pump correctly attached to tractor. Oil reservoir filled to capacity and system inspected for leaks (If applicable).
- Bulkfill/dry fertilizer hoses remain in place with no belt slipping or hose pinching between stub wing and vacuum manifold.

Planter has been thoroughly checked and to the best of my knowledge is ready for delivery to the customer.

(Signature of Set-Up Person/Dealer Name/Date)

OWNER REGISTER

Name _____ Delivery Date _____
 Street Address _____ Model No. 4805 Serial No. _____
 City, State/Province _____ Dealer Name _____
 ZIP/Postal Code _____ Dealer No. _____

DELIVERY CHECKLIST

Use the following checklist at time planter is delivered as a reminder of very important information which should be conveyed to retail customer/end user. Check off each item as it is fully explained.

- Check proper operation of vacuum fan, bulk fill fan, and PTO-driven pump (If applicable) with tractor used with planter.
- Life expectancy of this or any other machine is dependent on regular lubrication as directed in the Operator Manual.
- All applicable safety precautions.
- Along with retail customer/end user, check reflective decals and SMV sign are clearly visible with planter in transport position and attached to tractor. Check safety/warning lights are in working condition. Tell retail customer/end user to check federal, state/provincial, and local regulations before towing or transporting on a road or highway.
- Give Operator Manual, Parts Manual, and all Instruction Sheets to retail customer/end user and explain all operating adjustments.
- Read warranty to retail customer/end user.
- Complete Warranty and Delivery Report form.

To the best of my knowledge this machine has been delivered ready for field use and customer has been fully informed as to proper care and operation.

(Signature of Delivery Person/Dealer Name/Date)

AFTER DELIVERY CHECKLIST

The following is a list of items we suggest to check during the first season of use of the equipment.

- Check planter performance with retail customer/end user.
- Check performance of vacuum seed metering system with retail customer/end user.
- Review importance of proper maintenance and adherence to all safety precautions with retail customer/end user.
- Check for parts that may need to be adjusted or replaced.
- Check all safety decals, reflective decals, and SMV sign are correctly located as shown in the Parts Manual and that decals are legible. Replace if damaged or missing.
- Check safety/warning lights are working properly.

(Signature of Follow-Up Person/Dealer Name/Date)

**All registrations must be submitted online at "business.kinze.com" within 5 business days of delivery.
Retain a copy of this form for auditing purposes.**

Tear Along Perforation

KINZE

OVERVIEW

To The Owner	1-1
General Information	1-3
Specifications	1-5
General Safety Rules	1-8
Safety Precautions	1-9
Safety Instructions, Signs, and Decals	1-10

MACHINE OPERATION

Loading and Unloading	2-1
Row Marker Safety Lockup	2-1
Transport Axle Cylinder Safety Lockup	2-2
Drawbar Hitch Lockup	2-3
Wing Latch Lockup	2-4
Initial Planter Preparation	2-4
Tractor Requirements	2-6
Piston PTO Pump	2-7
Oil Specification	2-7
PTO Connection Procedure	2-8
Tractor Preparation and Hookup	2-9
Cylinder Information	2-12
Hydraulic Hose Information	2-14
Transporting Planter	2-23
Level Planter	2-24
Jump Start Sensor	2-24
Ag Leader InCommand 1200 Display	2-25
Kinze Blue Vantage®	2-25
Field Operation	2-25
Transport to Field Sequence	
Using Kinze Blue Vantage® System	2-26
Transport to Field Sequence	
Using Control Box (AgLeader)	2-26
Field to Transport Sequence	
Using Kinze Blue Vantage® System	2-30
Field to Transport Sequence	
Using Control Box (AgLeader)	2-30
Row Marker Operation	
Using Kinze Blue Vantage® System	2-33
Row Marker Operation using Control Box (AgLeader)	2-33
Row Marker Speed Adjustment	2-34
Row Marker Cable Adjustment	2-36
Row Marker Length And Disc Blade Adjustment	2-37
Vacuum Meter System	2-38
Analog Vacuum or Pressure Gauge	2-38
Bulk Fill System	2-39
Bulk fill Entrainer Access	2-40
Bulk Fill Tanks - Clean Out	2-41

Bulk Fill Scale Package Option	2-41
Point Row Clutches	2-45
Field Test	2-46
Field Test using Blue Vantage System	2-46
Field Check Seed Population	2-46
Determining Kilograms Per Hectare	2-47
Determining Liters Per Hectare	2-47
Field Check Granular Chemical Application	2-48
Water Tank	2-49

ROW UNIT OPERATION

Planting Depth	3-1
“V” Closing Wheel Adjustment (Rubber or Cast Iron)	3-1
Closing Wheel Shield (Rubber or Cast Iron “V” Closing Wheels)	3-1
Quick Adjustable Down Force Springs Option	3-2
Pneumatic Down Pressure (PDP)	3-3
Field Operation	3-3
Vacuum Settings	3-5
Seed Meter Clean out	3-8
Additives	3-9
Spiked Closing Wheel	3-11
Row Unit Mounted No Till Coulter	3-11
Coulter Mounted Residue Wheels	3-12
Granular Chemical Banding Options	3-12
Granular Chemical Hopper and Drive	3-13
Preparing the System for Operation	4-1
Piston Pump	4-2
Startup Procedure	4-3
PTO Pump Drive Startup Procedure	4-5
Calibration Procedure	4-6
Notched Single Disc Openers	4-7
Depth/Gauge Wheel Attachment for Notched Single Disc Fertilizer Opener	4-8
Liquid Fertilizer Attachment	4-9
System overview	4-10
Centrifugal Pump	4-10
Check Valves	4-13
Rear Trailer Hitch Option	4-13

RATE CHARTS 5-1**LUBRICATION AND MAINTENANCE**

Lubrication	6-1
Wheel Bearings	6-1
Grease Fittings	6-2
Notched Single Disc Opener	6-6

PTO Shaft Coupling	6-6	Solenoid Valve	7-6
Mounting Bolts and Hardware	6-7	PTO Pump Drive and Oil Cooler Option	7-6
Fertilizer Maintenance	6-10		
Vacuum Seed Meter Maintenance	6-12		
Seed Meter Cleanout	6-12		
Vacuum Manifold Maintenance	6-13		
Gauge Wheel Adjustment	6-13		
Gauge Wheel Arm Bushing/Seal Replacement	6-14		
15" Seed Opener Disc Blade/Bearing Assembly	6-15		
Seed Tube Guard/Inner Scraper	6-16		
Row Unit Mounted No Till Coulter	6-17		
Coulter or Row Unit Mounted Residue Wheels	6-17		
Tractor Mounted Pump Drive and Oil Cooler	6-18		
Check Valve	6-19		
Flow Control Valves	6-19		
Pressure Relief Valves	6-19		
Pressure Compensated Flow Control Valves	6-19		
Solenoid Valve	6-20		
Pneumatic Down Pressure Air Compressor Tank	6-20		
True Depth Hydraulic System Servicing	6-21		
True Depth Filter	6-22		
Row Marker Bearing Lubrication or Replacement	6-23		
Transport and Lift/Ground Drive Wheel Bearing Repack or Replacement	6-24		
Fertilizer Check Valve Cleaning and Repair	6-25		
Liquid Fertilizer Piston Pump Crankcase Oil Level	6-25		
Piston Pump Maintenance	6-25		
Piston Pump Storage	6-26		
Preparation for Storage	6-27		
Tire Pressure	6-28		
Inflation Specifications	6-28		
Hydraulic Hose Life	6-29		
Lift/Fold/Wing Downforce Hydraulic Schematic	6-30		
Vacuum and Bulk Dry Fertilizer System			
Hydraulic Schematic	6-32		
Power Pack Wiring Diagram (Blue Drive)	6-34		
Battery Care	6-35		
Electrical Control Console Connections - AgLeader	6-36		
Cables and Harnesses	6-38		
Ethernet Cables	6-39		

TROUBLESHOOTING



Bulk Fill	7-1
Closing Wheel	7-1
Piston Pump	7-2
Row Marker Operation	7-3
Vacuum Seed Meter	7-4

Kinze Manufacturing, Inc. thanks you for your patronage. We appreciate your confidence in Kinze farm machinery. Your Kinze planter has been carefully designed to provide dependable operation in return for your investment.

This manual has been prepared to aid you in the operation and maintenance of the planter. It should be considered a permanent part of the machine and remain with the machine when you sell it.

It is the responsibility of the user to read and understand the Operator Manual in regards to safety, operation, lubrication and maintenance before operation of this equipment. It is the user's responsibility to inspect and service the machine routinely as directed in the Operator Manual. We have attempted to cover all areas of safety, operation, lubrication and maintenance; however, there may be times when special care must be taken to fit your conditions.

Throughout this manual the symbol  and the words **DANGER**, **WARNING**, and **CAUTION** are used to call attention to safety information that if not followed, will or could result in death or injury. **NOTICE** and **NOTE** are used to call your attention to important information. The definition of each of these terms follows:

 DANGER	<p>Indicates an imminently hazardous situation that, if not avoided, will result in death or serious injury. This signal word is to be limited to the most extreme situations, typically for machine components which, for functional purposes, cannot be guarded.</p>
 WARNING	<p>Indicates a potentially hazardous situation that, if not avoided, could result in death or serious injury, and includes hazards that are exposed when guards are removed. It may also be used to alert against unsafe practices.</p>
 CAUTION	<p>Indicates a potentially hazardous situation that, if not avoided, may result in minor or moderate injury. It may also be used to alert against unsafe practices.</p>
NOTICE	<p>Used to address safety practices not related to personal injury.</p>

NOTE: Special point of information or machine adjustment instructions.

**WARNING**

Improperly operating or working on this equipment could result in death or serious injury. Read and follow all instructions in Operator's Manual before operating or working on this equipment.

**WARNING**

Some photos in this manual may show safety covers, shields, or lockup devices removed for visual clarity. **NEVER OPERATE OR WORK ON** machine without all safety covers, shields, and lockup device in place as required.

NOTE: Some photos in this manual may have been taken of prototype machines. Production machines may vary in appearance.

NOTE: Some photos and illustrations in this manual show optional attachments installed. Contact your Kinze Dealer for purchase of optional attachments.

The Kinze Limited Warranty for your new machine is stated on the retail purchaser's copy of the Warranty And Delivery Receipt form. Additional copies of the Limited Warranty can be obtained through your Kinze Dealer.

Warranty, within the warranty period, is provided as part of Kinze's support program for registered Kinze products which have been operated and maintained as described in this manual. Evidence of equipment abuse or modification beyond original factory specifications will void the warranty. Normal maintenance, service and repair is not covered by Kinze warranty.

To register your Kinze product for warranty, a Warranty And Delivery Receipt form must be completed by the Kinze Dealer and signed by the retail purchaser, with copies to the Dealer, and to the retail purchaser. Registration must be completed and submitted to Kinze Manufacturing, Inc. within 5 business days of delivery of the Kinze product to the retail purchaser. Kinze Manufacturing, Inc. reserves the right to refuse warranty on serial numbered products which have not been properly registered.

If service or replacement of failed parts which are covered by the Limited Warranty are required, it is the user's responsibility to deliver the machine along with the retail purchaser's copy of the Warranty And Delivery Receipt to the Kinze Dealer for service. Kinze warranty does not include cost of travel time, mileage or hauling. Any prior arrangement made between the Dealer and the retail purchaser in which the Dealer agrees to absorb all or part of this expense should be considered a courtesy to the retail purchaser.

Kinze warranty does not include cost of travel time, mileage, hauling, or labor.

GENERAL INFORMATION

The Model 4805 Front Folding Planter is available with either True Rate or True Speed vacuum meters, conventional hoppers or bulk fill tanks, liquid or dry fertilizer, and various other options. Contact your Kinze Dealer for additional details.



Model 4805 24 Row Bulk Fill Planter

Information used in these instructions was current at time of printing. However, due to Kinze’s ongoing product improvement, production changes may cause your machine to appear slightly different in detail. Kinze Manufacturing, Inc. reserves the right to change specifications or design without notice and without incurring obligation to install the same on machines previously manufactured. To obtain the most recent version of your publication, please contact your Kinze dealer.

Right hand (R.H.) and left hand (L.H.), as used throughout this manual, are determined by facing direction machine travels in use unless otherwise stated.

NOTE: Metric unit values in parentheses are approximate values and are to be used for reference only.

TOOLS REQUIRED

Hardware Size / Tool Required			
1/4" = 7/16"	7/16" = 5/8" (nut for 7/16" hardware uses 11/16" tool)	3/4" = 1 1/8"	1 1/4" = 1 7/8"
5/16" = 1/2"	1/2" = 3/4"	7/8" = 1 5/16"	1 1/2" = 2 1/4"
3/8" = 9/16"	5/8" = 15/16"	1" = 1 1/2"	

SPECIFICATIONS

Specification	Bulk Fill	Conventional	Bulk Dry Fertilizer
Number of Rows	24	24	24
Row Spacing	70 cm	70 cm	70 cm
Weight Base Machine	14570 kg	12946 kg	17000 kg
Hitch Weight -- Transport	5000 - 5750 kg		
Hitch Weight -- Planting	730 - 2300 kg		
Transport Height	3,81 m	2,98 m	3,85 m
Planting Height	3,01 m	2,20 m	3,60 m
Planting Length	9,32 m*	9,32 m*	9,32 m*
	* add 0,65 m to planting length for optional granular chemical hoppers		
Transport Length	13,50 m*	13,40 m*	
	* add 0,65 m to transport length for optional granular chemical hoppers		
Planting Width	17,53 m	17,53 m	17,70 m
Transport Width	4,75 m*	4,75 m*	4,75 m*
	* add 0,65 m to transport width for optional granular chemical hoppers		
Seed Capacity	3875 l (2 x 1938 l Tanks)	1608 l (24 x 67 l Tanks)	1760 l (2 x 880 l Tanks)
Hydraulic Lift System	Four Master, Four Slave		
Row Markers	Independently controlled, three stage, disk blade depth bands		

Tire Specifications

Specification	Conventional Hoppers	Bulk Fill
Transport Tire Size	11- 22.5 14 PR	11- 22.5 14 PR
Transport Tire Pressure	90 PSI (6,20 bar)	90 PSI (6,20 bar)
Wing Tires	11- 22.5 (4)	11- 22.5 (4)
Field Tire Pressure	90 PSI (6,20 bar)	60 PSI (4,14 bar)
Piston Pump Drive Tires (Optional)	7.60" x 15" (2)	
Field Lift	Four Master/Four Slave Hydraulics	
Row Markers	Independently controlled, three stage fold, disk blade depth bands.	

KINZE 4805 70CM PLANTERS		
Tractor Hydraulic* and Power Requirements**		
Meters	True Rate®	True Speed®
Hoppers	Row Hoppers	Bulk Fill
Drive	Blue Drive®	Blue Drive®
SCV Requirements		
Lift	2*	2**
Rotate/Marker	1	1
Bulk Fill (seed)	-	PTO
Vacuum	PTO	PTO
Blue Drive® / Blue Vantage®	PTO	PTO
Bulk Dry (fertilizer)	1	1
Number of SCV (w/ PTO):	4	4
Number of SCV (w/o PTO):	6****	6****
Hydraulic Capacity Requirements (l/min)		
Liquid Fertilizer	15	15***
True Depth®	49***	49***
Lift & Fold (SCV)	125	125
Bulk Fill (seed)	---	30***
Bulk Fertilizer (SCV)	83	83
Vacuum	49***	49***
Blue Drive® / Blue Vantage®	30***	30***
Estimated minimum flow (w/ Dry Fertilizer & PTO):	208	208
Estimated minimum flow (w/ Liquid Fertilizer & PTO):	140	125
Estimated minimum flow (w/ Dry Fertilizer, w/o PTO):	337****	367****
Estimated minimum flow (w/ Liquid Fertilizer, w/o PTO):	267****	299****
Tractor Power Requirements (HP)		
Power requirements (HP)	From 400	From 500

*2x return hoses, 1 pressure. With liquid fertilizer -- 2x return, 2x pressure.

**2x return hoses, 1 pressure.

***driven by PTO

****Non-standard configuration

¹All data above is indicative, the table shown above describes the specific hydraulic demands by planter model and functional area. Planter hydraulic requirements depend on a specific planter configuration.

²Soil type, field tillage, terrain, and planter configuration might affect tractor power requirements.

KINZE 4805 70CM PLANTERS			
Tractor Hydraulic* and Power Requirements**			
True Rate®	True Rate®	True Speed®	True Rate®
Bulk Fill	Bulk Fill	Bulk Fill	Bulk Fill
Blue Drive®	Blue Drive®	Blue Drive®	Ground Contact Drive
SCV Requirements			
2**	2**	2**	2*
1	1	1	1
PTO	PTO	PTO	1
PTO	PTO	PTO	1
PTO	PTO	PTO	-
1	1	1	-
4	4	4	-
6****	6****	6****	5****
Hydraulic Capacity Requirements (l/min)			
15***	15***	15***	-
49***	49***	49***	-
125	125	125	125
30***	30***	30***	30
83	83	83	-
49***	49***	49***	49
30***	30***	30***	-
208	208	208	-
125	125	125	-
367****	367****	367****	-
299****	299****	299****	-
Tractor Power Requirements (HP)			
From 400	From 400	From 500	From 400

*2x return hoses, 1 pressure. With liquid fertilizer -- 2x return, 2x pressure.

**2x return hoses, 1 pressure.

***driven by PTO







****Non-standard configuration

¹All data above is indicative, the table shown above describes the specific hydraulic demands by planter model and functional area. Planter hydraulic requirements depend on a specific planter configuration.

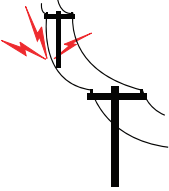
²Soil type, field tillage, terrain, and planter configuration might affect tractor power requirements.

1. Read and understand instructions provided in this manual and warning labels. Review these instructions frequently!
 2. This machine is designed and built with your safety in mind. Do not make any alterations or changes to this machine. Any alteration to design or construction may create safety hazards.
 3. A large portion of farm accidents happen from fatigue or carelessness. Safe and careful operation of tractor and planter will help prevent accidents.
 4. Never allow planter to be operated by anyone unfamiliar with operation of all functions of the unit. Operators must read and thoroughly understand all instructions given in this manual before operating or working on equipment.
 5. Be aware of bystanders, particularly children! Always look around to make sure it is safe to start tow vehicle engine or move planter. This is particularly important with higher noise levels and quiet cabs, as you may not hear people shouting.
 6. Make sure planter weight does not exceed towing capacity of tractor, or bridge and road limits. This is critical to maintain safe control and prevent death or injury, or property and equipment damage.
 7. Never ride or allow others to ride on planter.
 8. Store planter in an area away from human activity. DO NOT permit children to play on or around the stored unit.
 9. Keep hands, feet, and clothing away from moving parts. Do not wear loose-fitting clothing which may catch in moving parts.
 10. Always wear protective clothing, shoes, gloves, hearing, and eye protection applicable for the situation.
 11. Do not allow anyone to stand between tongue or hitch and towing vehicle when backing up to planter.
 13. Prevent electrocution, other injuries, or property and equipment damage. Watch for obstructions such as wires, tree limbs, etc. when operating machine. Be aware of clearances during turns and when folding/unfolding planter.
 14. Reinstall all guards removed for maintenance activities. Never leave guards off during operation.
 15. Use of aftermarket hydraulic, electric, or PTO drives may create serious safety hazards to you and people nearby. If you install such drives, follow all appropriate safety standards and practices to protect you and others near this planter from injury.
 16. Follow all federal, state/provincial, and local regulations when towing farm equipment on a public highway. Use safety chain (not an elastic or nylon/plastic tow strap) to retain connection between towing and towed machines in the event of primary attaching system separation.
 17. Make sure all safety/warning lights, SMV sign, and reflective decals are in place and working properly before transporting the machine on public roads.
 18. Limit towing speed to 20 km/h. Tow only with a farm tractor equipped with a minimum of a Cat 4 hitch. Allow for unit length when making turns.
 19. Reduce speed prior to turns to avoid the risk of overturning. Always drive at a safe speed relative to local conditions and ensure your speed is slow enough for a safe emergency stop.
 20. Chemical application is often an integral part of planting. Follow label instructions for proper chemical mixing, handling and container disposal methods.
 21. Be familiar with safety procedures for immediate first aid should you accidentally contact chemical substances.
 22. Use the proper protective clothing and safety equipment when handling chemicals.
 23. Chemicals are supplied with Material Safety Data Sheets (MSDS) that provide full information about the chemical, its effects on exposure, and first aid needs in the event of an emergency. Keep your MSDS file up-to-date and available for first responders in case of emergency.
 24. When servicing ground engaging components such as opening disks and firming points, use special care to avoid points and edges worn sharp during use.
 25. Use professional help if you are unfamiliar with working on hydraulic systems. Pressurized hydraulic fluid can penetrate body tissue and result in death, serious infection, or other injuries.
 26. Disposing of waste improperly can threaten the environment. To dispose of your equipment properly contact your local environmental or recycling center.
- Never pour waste onto the ground, down a drain, or into any water source.
- When disposing of waste such as oil, use leakproof containers. Be sure to use containers that do not resemble food or beverage which may mislead someone into consuming them. Dispose of oil per your local, regional requirements.
- When disposing of any fertilizer chemicals used, contact the supplier of the chemicals.
- Model 4805 planter consists of 85% recyclable metals, 10% recyclable plastic and rubber, and 5% waste.

Following are some common hazard warnings associated with this equipment. Pay close attention to all safety, operating, and maintenance information in this manual and decals applied to your equipment.

 DANGER 	<p>Contacting or coming close to power lines or other high energy sources will cause death or serious injury.</p> <p>Keep away from power lines or high energy sources at all times.</p>
 WARNING 	<p>Improperly operating or working on this equipment could result in death or serious injury. Read and follow all instructions in Operator Manual before operating or working on this equipment.</p>
 WARNING 	<p>Falling equipment can cause death or serious injury. Install all lockup devices or lower planter to ground before working on equipment.</p>
 WARNING 	<p>Explosive separation of rim and tire parts can cause death or serious injury. Overinflation, rim and tire servicing, improper use of rims and tires, or worn or improperly maintained tires could result in a tire explosion.</p>

SAFETY SIGNS AND DECALS

	<p>All safety/warning lights, reflective decals, and SMV sign must be in place and visible before transporting machine on public roads or death, serious injury, and damage to property and equipment may result. Check federal, state/provincial, and local regulations before transporting equipment on public roads.</p>
---	---





Safety signs and decals are placed on the machine to warn of hazards and provide important operating and maintenance instructions. Information on these signs are for your personal safety and the safety of those around you. FOLLOW ALL SAFETY INSTRUCTIONS!

- Keep signs clean so they can be easily seen. Wash with soap and water or cleaning solution as required.
- Replace safety signs if damaged, painted over, or missing.
- Check reflective decals and SMV sign periodically. Replace if they show any loss of reflective properties.
- When replacing decals, clean machine surface thoroughly with soap and water or cleaning solution to remove all dirt and grease.



NOTE: Safety sign and decal locations are also shown in the Parts Manual for this machine.

NOTE: Style and locations of SMV sign, reflective decals, and safety/warning lights conform to ANSI/ASABE S279.14 JUL 2008 and ANSI/ASABE S276.6 JAN 2005.



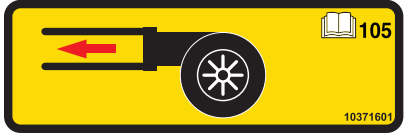
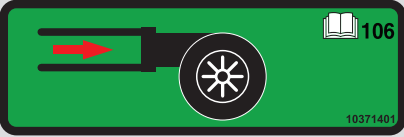
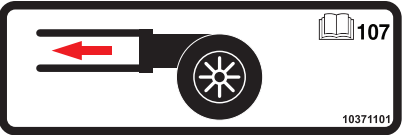
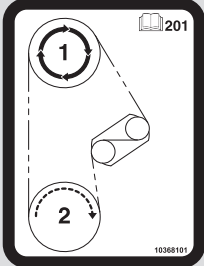

PICTORIAL DECALS

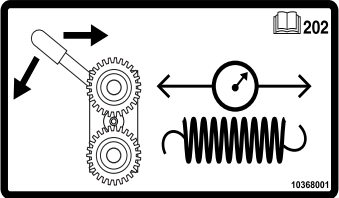
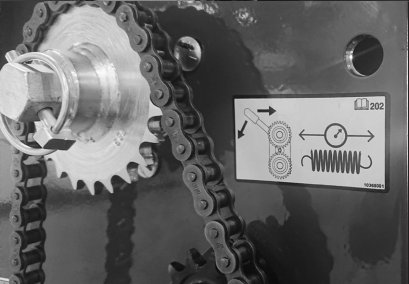
No.	Decal	Placement	Meaning
101			Oil/Grease daily.
102			Oil/Grease weekly.



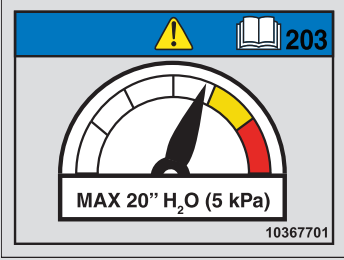

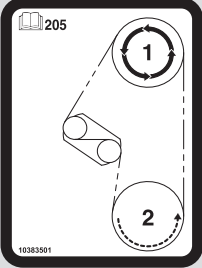
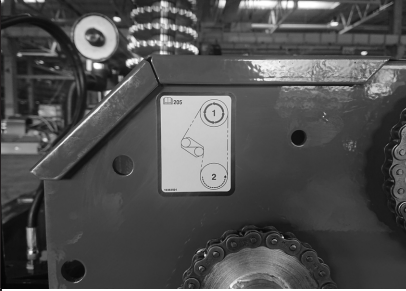
PICTORIAL DECALS

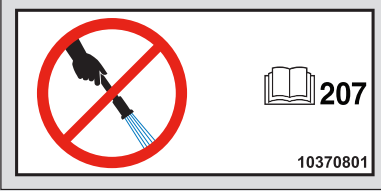
No.	Decal	Placement	Meaning
105		Below Bulk Fill pressure gauge.	Bulk Fill.
106		Below Vacuum gauge.	Vacuum.
107		Below Bulk Dry Fertilizer Gauge.	Bulk Dry Fertilizer.
201			Upper sprocket is the drive sprocket. Lower sprocket is the driven sprocket.
202			Rotate knurled collar on wrap spring tightener to release spring tension.



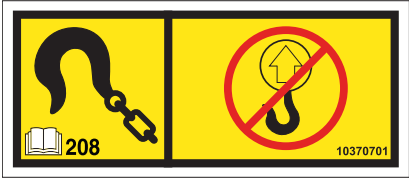

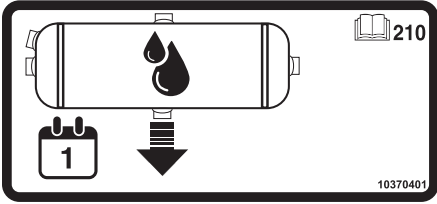
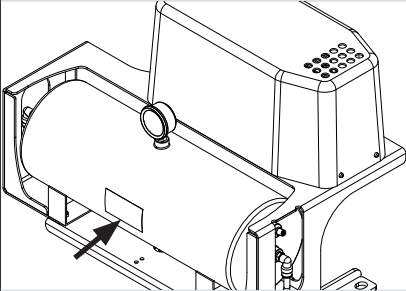
PICTORIAL DECALS

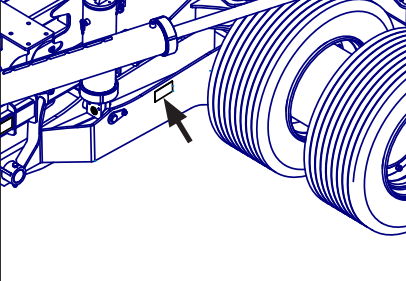
No.	Decal	Placement	Meaning
203			<p>Maximum operating pressure is 20" H₂O (5 kPa). Higher pressure can cause seed bridging.</p>
204		<p>On Bulk Fill tank.</p>	<p>Apply a minimum of 16 (0.45 kg) ounces of graphite per 50 units of seed.</p>
205			<p>Upper sprocket is the drive sprocket. Lower sprocket is the driven sprocket.</p>
206		<p>On IPN module.</p>	<p>Ensure that O-Ring(s) are in place on M12 connector(s) (Ethernet). Ensure that M12 connector(s) are torqued to 0.7 Nm.</p>
207		<p>Under PMM module's mount.</p>	<p>DO NOT wash modules directly with cover removed.</p>



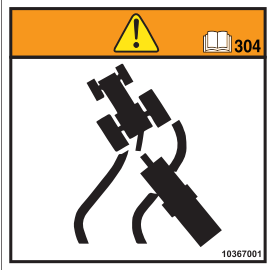
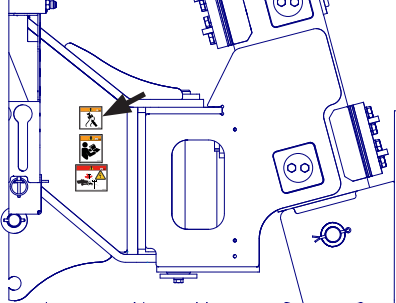

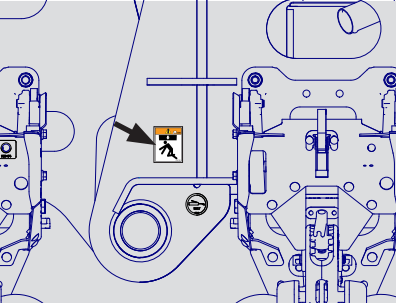
PICTORIAL DECALS

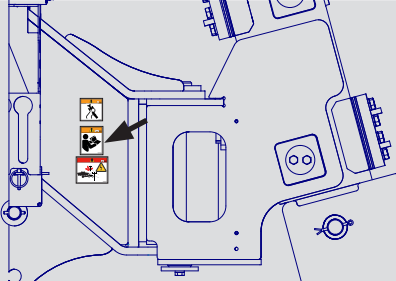
No.	Decal	Placement	Meaning
208			Shipping tie down point. Do not use for lifting.
209			Lifting point.
210			<p>Drain moisture from air tank daily.</p> <p>Drain tank completely for storage.</p>
213		On water tank.	Water for emergency rinse.
301			Overinflation may cause explosive separation of tire and rim, which could result in death or serious injury. Follow inflation specifications and maintenance instructions in the Operator's Manual.



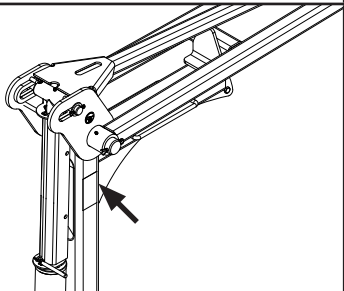

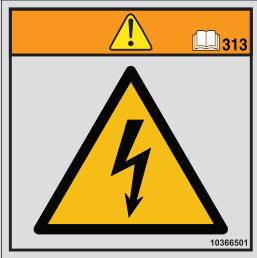

PICTORIAL DECALS

No.	Decal	Placement	Meaning
302		<p>On insecticide hopper lids.</p>	<p>Agricultural chemicals can cause death or serious injury to persons, animals, and plants or seriously damage soil, equipment, and property. Read and follow all chemical and equipment manufacturer labels and instructions.</p>
304			<p>Loss of control can cause death or serious injury, or damage to property and equipment. Tow only with farm tractor weight rated and configured for this equipment. Use safety chains and transport as specified in the Operator's and Parts Manuals.</p>
306			<p>Uncontrolled machine movement can crush resulting in death, serious injury, or damage to property and equipment.</p> <p>Install safety lockup devices before working under or transporting this equipment.</p>
307			<p>Removing this wheel and axle assembly can cause equipment to tip over, which could result in death, serious injury, or damage to property and equipment.</p>
308			<p>Improperly operating or working on this equipment could result in death or serious injury. Read and follow all instructions in Operator Manual before operating or working on this equipment.</p>

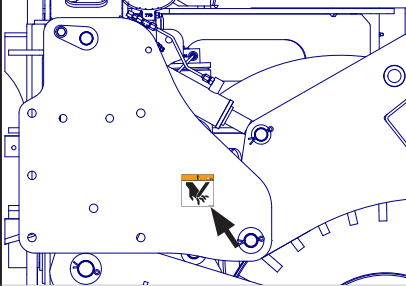
PICTORIAL DECALS

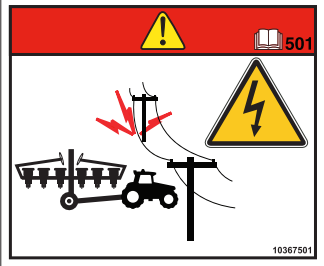
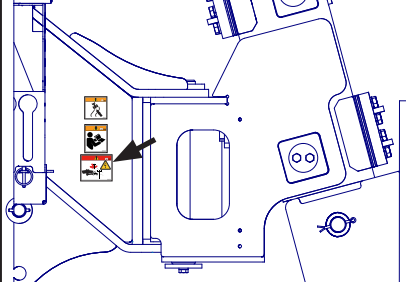
No.	Decal	Placement	Meaning
309			<p>Row marker can lower at any time and could cause death or serious injury.</p> <p>Stay away from row markers!</p> <p>Install safety lockup device when not in use.</p>
310			<p>Uncontrolled movement of planter components can cause death, serious injury, or damage to property and equipment.</p> <p>Raise planter and install cylinder lockups before folding. Fold on level ground. Install wing safety latches before towing.</p>
311			<p>Do not remove lid during machine operation. Contents are pressurized and interference could result in death, serious injury or equipment damage.</p> <p>See the Operator's Manual for proper filling procedure.</p>
313		<p>On Catwalk ladder.</p>	<p>Static electricity shock hazard. Static electricity charge may build up during use of planter and discharge when refilling or performing maintenance.</p> <p>Electronic medical devices, such as pacemakers and defibrillators, may malfunction from shock of static electricity discharge.</p> <p>Persons wearing electronic medical devices should use caution to avoid shock when working around planter.</p>

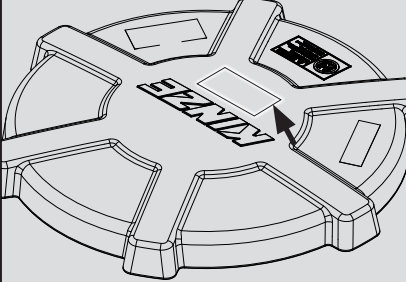
PICTORIAL DECALS

No.	Decal	Placement	Meaning
314			
401			<p>Fan can start at any time. Operating fan can blow debris and has a high noise level.</p> <p>Always wear eye and hearing protection when working around fan.</p>
501			<p>Contacting with or coming close to power lines or other high energy sources will cause death or serious injury.</p> <p>Keep away from power lines or high energy sources at all times.</p>
502			
503		<p>On Bulk Fill ladder.</p>	<p>Falling from equipment can cause death or serious injury.</p> <p>Use three points of contact when working on equipment.</p> <p>Never ride on equipment.</p>

LOADING AND UNLOADING

The planter is to be rolled on and off the trailer. If roll-on-off is not possible, lift locations have been identified via a label.



ROW MARKER SAFETY LOCKUP

WARNING

Row marker can lower at any time and could cause death or serious injury. Stay away from row markers! Install safety lockup device when not in use.

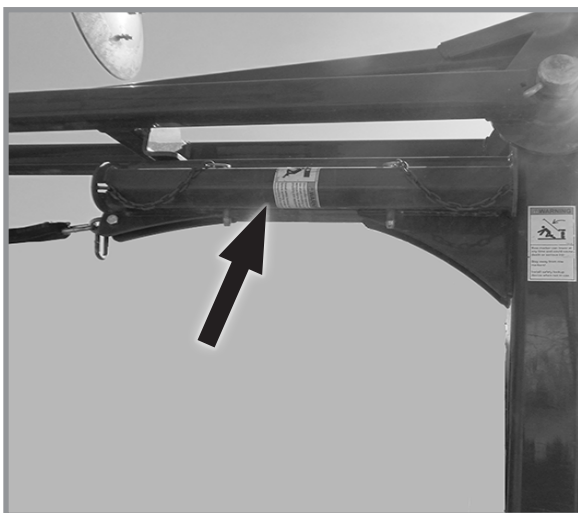

Row Marker Safety Lockup Stored



Row Marker Safety Lockup Installed

Always install row marker lockups when working on, storing, or transporting planter. Hold in place with two clevis pins.

TRANSPORT AXLE CYLINDER SAFETY LOCKUP

 WARNING	<p>Transport axle can lower from transport position without the use of any controller, causing death, serious injury, or damage to property and equipment. Do not operate any hydraulic function while transporting the planter. Make sure all transport safety lockups are installed on the four transport cylinders and all SCV controls are in their neutral state before transporting, storing and working on the planter.</p>
--	--

Cylinder lockup storage location



Cylinder lockup

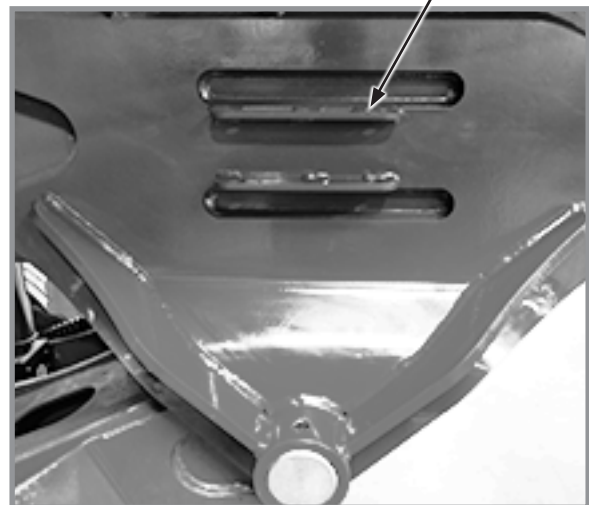

Cylinder lockup storage location

Transport axle cylinder lockup installed

Transport axle cylinder lockups are required on both transport cylinders on planter when working on, storing, or transporting planter.

Fully extend cylinder to raised position. Install transport axle cylinder lockups. Insert wire lock pin through holes on cylinder lockup and secure.

Store transport axle cylinder lockups in cylinder lockup storage location before operating planter.

 **WARNING**

Tanks must be empty when transporting to avoid death, serious injury, or damage to property or equipment. Do not pull planters in transport configuration with seed or fertilizer in tanks.



 **WARNING**

Planter hitch may raise uncontrollably during folding/unfolding and can cause death, serious injury, or damage property and equipment. DO NOT fold or unfold planter without planter attached to a tractor. DO NOT unhitch planter from tractor unless fully folded for transport or fully unfolded with planting units lowered to ground.

 **WARNING**

Uncontrolled movement of equipment can cause loss of control and could result in death, serious injury, or damage to property and equipment. Install all safety pins before transporting equipment.



DRAWBAR HITCH LOCKUP

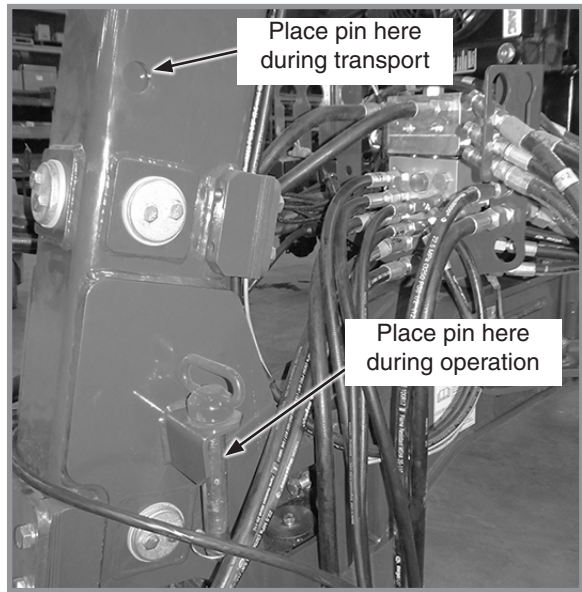

Place the drawbar hitch lockup pin in the hole shown above when machine is in operation.

WING LATCH LOCKUP





Hitch Release from Wing Latch

 WARNING	Improperly operating or working on this equipment could result in death or serious injury. Read and follow all instructions in Operator Manual before operating or working on this equipment.
	

INITIAL PLANTER PREPARATION

Following information is general in nature to aid in preparation of tractor and planter for use, and to provide general operating procedures. Operator experience, familiarity with the machine, and the following information should combine for efficient planter operation and good working habits.

 WARNING	Explosive separation of rim and tire parts can cause death or serious injury. Overinflation, rim and tire servicing, improper use of rims and tires, or worn or improperly maintained tires could result in a tire explosion.
	

 WARNING	Wheel separation can cause loss of control resulting in death, serious injury, or damage to property and equipment. Check lug nuts on transport wheels are tight before operating planter for first time and periodically after.
--	---



Tire Locations (R.H. shown)

1. Torque transport wheel lug nuts according to instructions indicated in image below.
2. Inflate tire. See [“Tire Specifications” on page 1-6.](#)
3. Lubricate planter and row units per lubrication information in this manual. See [“Lubrication and Maintenance” on page 6-1](#)
4. Check all drive chains for proper tension, alignment, and lubrication.



TRACTOR REQUIREMENTS**WARNING**

Loss of control of equipment during transport can result in death, serious injury, or damage to property and equipment. Tractor gross weight must be greater than planter gross weight with attachments and options.

NOTICE

Connect hydraulic motor case drain to a case drain return line with zero PSI on tractor. Failure to connect to a return with zero PSI will cause hydraulic motor shaft seal damage. **DO NOT** connect hydraulic motor case drain to a SCV outlet or motor return circuit connection. Contact tractor manufacturer for specific details on “zero pressure return”.

NOTICE

All Hydraulic Requirements: Minimum Pressure 2350 PSI (~16200 kPa); Maximum Pressure 3000 PSI (~20700 kPa). Check tractor hydraulics to ensure that maximum pressure cannot be exceeded.

Consult your dealer for information on horsepower requirements and tractor compatibility. Requirements vary with planter options, tillage, and terrain.

Three dual remote hydraulic outlets (SCV) are required on all sizes of conventional planters equipped with row markers.

Four dual remote hydraulic outlets (SCV) are required on all sizes of bulk fill planters equipped with row markers. A 12 VDC electrical system is required on all sizes.

Six dual remote hydraulic outlets (SCV) are required on all sizes of planters equipped with vacuum meters but without PTO pump.

PISTON PTO PUMP

Kinze 4805 planters require a 1 $\frac{3}{4}$ " (~5 cm)-20 or 1 $\frac{3}{8}$ " (~4 cm)-21 spline 1000 RPM PTO to operate PTO-driven hydraulic piston pump capable of supplying 98 l/min to vacuum and bulk fill fans.

NOTE: A tractor model-specific mount kit is required for the PTO-mounted pump.

Contact Ag Power Systems, LLC (www.agpowersystems.com).

Vacuum Seed Metering System operates from a 8 gal (~30 l) capacity oil reservoir.

NOTE: Check that open center plug is removed from fan block before operating.

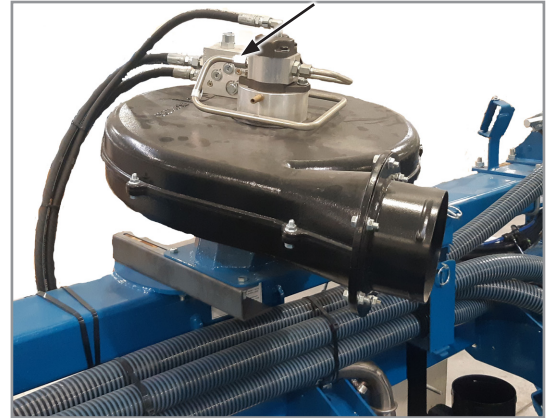

Vacuum Fan Block

Other dual fan system components include one oil cooler, one replaceable cartridge-type filter, and two pressure compensating flow-control valves.

OIL SPECIFICATION

Hydraulic transmission oil is used in the planter and PTO. The oil chemical properties:

Viscosity, mm ² /s @ 100 °C. ASTM D-445	10
Viscosity, mm ² /s @ 40 °C. ASTM D-445	63
Viscosity Index ASTM D-2270	143
TBN, mg KOH/g ASTM D-2896	9
TAN, mg KOH/g (ASTM D-664)	2
Pour Point, °C ASTM D-5950	-42
Specific Gravity @ 15.6°C. ASTM D-4052	0,876
Flash Point, COC, °C. ASTM D-92	220

NOTE: Factory filled with VALVOLINE™ UNITRAC SAE 80W.

WARNING

Pressurized hydraulic fluid can penetrate body tissue and result in death, serious infection, or other injuries. Fluid injected under skin must be **IMMEDIATELY** removed by a surgeon familiar with this type of injury. Make sure connections are tight and hoses and fittings are not damaged before applying system pressure. Leaks can be invisible. Keep away from suspected leaks. Relieve pressure before searching for leaks or performing any system maintenance.

PTO CONNECTION PROCEDURE

1. Park the tractor on a level surface. Turn tractor off.
2. Clean the PTO shaft of the tractor.
3. Connect the PTO pump to the tractor.
4. Install the retaining bracket on the drawbar of the tractor to prevent the PTO pump from turning.
5. Check the oil level in the oil tank.
6. Verify that supply valve on the reservoir to the PTO pump is open.
7. Ensure the suction hose is free of bends as this could stop the oil flow to the PTO pump.
8. Start the tractor and operate the PTO at low speed.

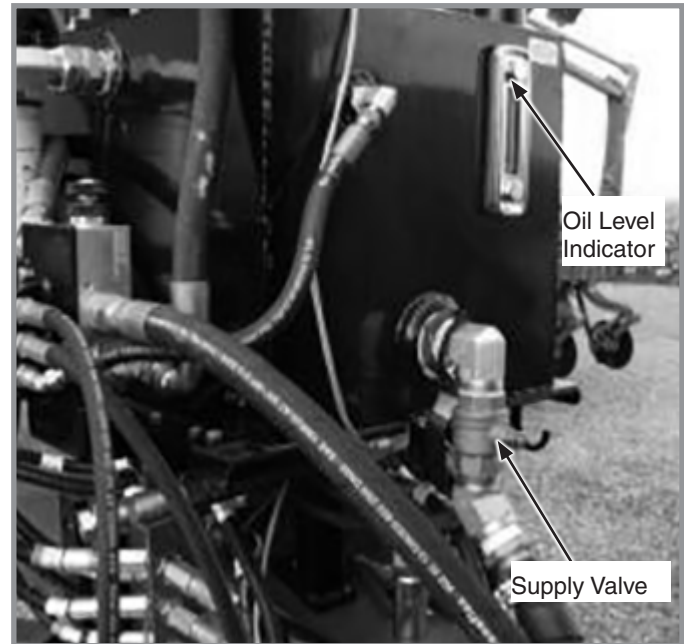

NOTICE

Always start the PTO at low rpm to avoid significant damage to PTO gearbox and pump.

9. Increase the engine speed of the tractor to reach 1000 rpm at the PTO.



WARNING

Keep people away from distributor before starting.

10. Adjust the flow control valve to reach the desired pressure in the air distribution system.
11. Proceed with the connection of electric cables in the cabin depending on the options on the applicator.
12. After all connections, check their functioning. Make the correction if necessary.

TRACTOR PREPARATION AND HOOKUP

1. Back tractor to planter and connect with minimum 1¼" (~3 cm) diameter hitch pin or 2 point hitch. Make sure hitch pin is secured with a locking pin or cotter pin if tractor is not equipped with a hitch pin locking device.

NOTE: DO NOT install safety chain using clevis mounting hardware. Safety chain MUST be installed separately.

2. For planters with drawbar hitch, safety chain must be used to keep planter and tractor connected in case of a hitch pin/drawbar failure. Attach safety chain at an unused clevis mounting hole on the planter hitch. Torque hardware to 1140 Nm.

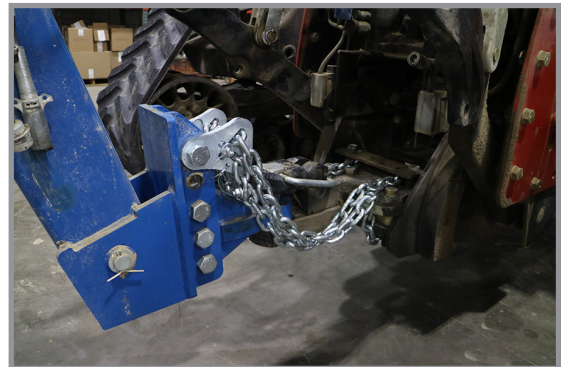

Tractor and Safety Chain Hookup for Drawbar Hitch

NOTICE

Routing of hydraulic hoses from planter to tractor is very important. If done improperly, hoses can be pinched, cut or broken when planter is operated.



WARNING



Pressurized hydraulic fluid can penetrate body tissue and result in death, serious infection, or other injuries. Fluid injected under skin must be **IMMEDIATELY** removed by a surgeon familiar with this type of injury. Make sure connections are tight and hoses and fittings are not damaged before applying system pressure. Leaks can be invisible. Keep away from suspected leaks. Relieve pressure before searching for leaks or performing any system maintenance.

NOTICE

Wipe hose ends to remove any dirt before connecting couplers to tractor ports or contamination may cause equipment failure.

NOTICE

Always connect hydraulic hydraulic weight transfer/motor return hose to tractor motor return port. Do not connect to tractor SCV unless through a motor spool or hydraulic motor failure can occur. If a motor return port is not available on the tractor, the SCV controlling the bulk fill system **MUST** be in the float position before planter is moved in planting or field raised position when bulk fill system is not in use.

- Connect hydraulic hoses to tractor ports in a sequence familiar and comfortable to the operator. Refer to chart on the following page.

Non-Blue Drive

Color and Label	Machine Function	Hose Size	Hose Function
Red Extend	Field Lift Hydraulic Weight Transfer	5/8"	Pressure/Return
Red Retract		5/8"	Pressure/Return
Yellow Retract		5/8"	Return
Blue Extend	Planter Fold & Row Marker	1/2"	Pressure/Return
Blue Retract		1/2"	Pressure/Return
Yellow Extend	Bulk Fill System Pressure Fan	1/2"	Pressure
**Yellow Retract		5/8"	Return
Green Extend	Vacuum Meter Fans	1/2"	Pressure
Green Retract		5/8"	Return

**Bulk Fill Return connects to Field Lift Return.

Blue Drive

Color and Label	Machine Function	Hose Size	Hose Function
Red Extend	Field Lift Hydraulic Weight Transfer	5/8"	Pressure/Return
Red Retract		5/8"	Pressure/Return
Yellow Retract		5/8"	Return
Blue Extend	Planter Fold & Row Marker	1/2"	Pressure/Return
Blue Retract		1/2"	Pressure/Return
Brown Extend	Dry Fertilizer	1/2"	Pressure
Brown Retract		5/8"	Return
Yellow Extend	Liquid Fertilizer	1/2"	Pressure
**Yellow Retract		5/8"	Return

*On Blue Drive planters, PTO Pump supplies oil flow for all other available options (alternator, True Depth®, Bulk Fill, True Rate® vacuum meters, etc.)

**Liquid Fertilizer Return connects to Field Lift Return on non-Bulk Fill planters.

PART NO.	LETTER	COLOR	SYMBOL
A26924-01	EXTEND	RED	← [Symbol]
A26924-02	RETRACT	RED	→ [Symbol]
A26924-03	EXTEND	BLUE	← [Symbol]
A26924-04	RETRACT	BLUE	→ [Symbol]
A26924-05	EXTEND	GREEN	← [Symbol]
A26924-06	RETRACT	GREEN	→ [Symbol]
A26924-07	EXTEND	YELLOW	← [Symbol]
A26924-08	RETRACT	YELLOW	→ [Symbol]
A26924-09	EXTEND	BLACK	← [Symbol]
A26924-10	RETRACT	BLACK	→ [Symbol]
A26924-11	RETRACT	ORANGE	→ [Symbol]
A26924-12	EXTEND	LT BROWN	← [Symbol]
A26924-13	RETRACT	LT BROWN	→ [Symbol]

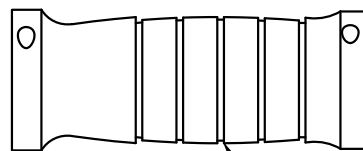

SEE CHART FOR COLOR, SYMBOL, AND PART NUMBER

NOTICE

Clean and grease PTO shaft coupling with high-pressure industrial coupling grease (Chevron® coupling grease or equivalent) meeting AGMA CG-1 and CG-2 Standards each time driveshaft is installed or premature wear and equipment failure can occur.

NOTE: A tractor model-specific PTO mount kit for dual section pump option is required and available from Ag Power Systems, LLC (www.agpowersystems.com).

4. (If applicable) Install PTO pump onto tractor PTO shaft. Make sure shaft rotation matches direction indicated on pump housing.
5. Connect ASABE Standards 7 terminal connector for safety/warning lights on planter to ASABE Standards receptacle on tractor. If your tractor is not equipped with an ASABE Standards receptacle, check with your tractor manufacturer for availability. Check warning lights on planter work in conjunction with warning lights on tractor.
6. Completely raise parking stands, located behind drawbar hitch, to prevent damage to stands and equipment when moving planter.
7. (If applicable) Connect compressor harness.
8. If equipped with True Depth®, attach the True Depth® 6 pin connector.
9. If equipped with Blue Drive®, attach the Blue Drive® 6 pin connector and Ethernet cable to the Blue Vantage® display.
10. Connect ASABE Standards 7 terminal connector for safety/warning lights on planter to ASABE Standards receptacle on tractor. If your tractor is not equipped with an ASABE Standards receptacle, check with your tractor manufacturer for availability. Check warning lights on planter work in conjunction with warning lights on tractor.

CYLINDER INFORMATION

	Row Marker Cylinder	Drawbar Hitch Cylinder	Fold Cylinder	Wing Cylinder	Master Cylinder
Intended Use	Double acting applications	Double acting applications	Double acting applications	Double acting applications	Double acting applications
Piston	Ductile iron	Ductile iron	Ductile iron	Ductile iron	Ductile iron
Gland	Ductile iron	Ductile iron	Ductile iron	Ductile iron	Ductile iron
Tube	ST 52 Dom	ST 52 Dom	ST 52 Dom	ST 52 Dom	ST 52 Dom
Rod	1045 Nitro rod	1045 Nitro rod	1045 Nitro rod	1045 Nitro rod	1045 Nitro rod
End Mounts	Sleeve	Through End Cap	Sleeve	Trunion	Clevis
Tube Seal	Buna O-ring with polytemp back-up	Buna O-Ring with polytemp back-up	Buna O-Ring with polytemp back-up	Buna O-ring with polytemp back-up	Buna O-ring with polytemp back-up
Rod Seal	Polyester alloy u-cup	Polyester alloy u-cup	Polyester alloy u-cup	Polyester alloy u-cup	Polyester alloy u-cup
Rod Wiper	Polyester alloy snap in	Polyester alloy snap in	Polyester alloy snap in	Polyester alloy snap in	Polyurethane alloy
Piston Seal	PTFE	T-seal HNBR	Polyurethane	Polyurethane	Polyurethane
Wear Ring Rod/Piston	N/A	Glass Reinforced Nylon	Glass Reinforced Nylon	Glass Reinforced Nylon	Glass Reinforced Nylon
Specifications					
Product Category	Hydraulic Cylinder	Hydraulic Cylinder	Hydraulic Cylinder	Hydraulic Cylinder	Hydraulic Cylinder
Maximum Stroke	20.75" (~52,71 cm)	35.28" (~89,61 cm)	65.16" (165,50 cm)	8.68" (22,03 cm)	12" (30,48 cm)
Working Pressure	3000 PSI (~20700 kPa)	3000 PSI (~20700 kPa)	3000 PSI (~20700 kPa)	3000 PSI (~20700 kPa)	3000 PSI (~20700 kPa)
Bore Size	3.5" (~8,89 cm)	4" (~10,16 cm)	6" (~15,24 cm)	3.75" (~9,53 cm)	6" (~15,24 cm)
Shaft Diameter	1.5" (~3,81 cm)	2.5" (~6,35 cm)	2.5" (~6,35 cm)	1.75" (~4,45 cm)	2.5" (~6,35 cm)
Cylinder Configuration	Simple	Simple	Simple	Simple	Simple
Cylinder Action	Double	Double	Double	Double	Double
Material	Steel, Ductile iron	Steel, Ductile iron	Steel, Ductile iron	Steel, Ductile iron	Steel, Ductile iron
Mounting Method	Sleeve	Sleeve	Sleeve	Trunion	Clevis
Mount Location	End Cap	End Cap	Sleeve	Trunion	Clevis
Cylinder Style	Welded	Welded	Welded	Welded	Welded

CYLINDER INFORMATION

	Wing Down Pressure Cylinder	Wing Hooks	Hitch Latch
Intended Use	Double acting applications	Double acting applications	Double acting applications
Piston	Ductile iron	Ductile iron	Ductile iron
Gland	Ductile iron	Ductile iron	Ductile iron
Tube	ST 52 Dom	ST 52 Dom	Ductile Iron
Rod	1045 Nitro rod	1045 Nitro rod	1045 Nitro rod
End Mounts	Sleeve	Sleeve	Through End Cap
Tube Seal	Buna O-ring with polytemp back-up	Buna O-ring with polytemp back-up	Buna O-ring with polytemp back-up
Rod Seal	Polyester alloy u-cup	Polyester alloy u-cup	Polyester alloy u-cup
Rod Wiper	Polyester alloy snap in	Polyester alloy snap in	Polyester alloy snap in
Piston Seal	Polyurethane	Polyurethane	T-seal HNBR
Wear Ring Rod/Piston	Glass Reinforced Nylon	Glass Reinforced Nylon	N/A
Specifications			
Product Category	Hydraulic Cylinder	Hydraulic Cylinder	Hydraulic Cylinder
Maximum Stroke	14.31 “ (~36,35 cm)	9.44” (~23,98 cm)	2.50” (~6,35 cm)
Working Pressure	3000 PSI (~20700 kPa)	3000 PSI (~20700 kPa)	3000 PSI (~20700 kPa)
Bore Size	2.5” (~6,35 cm)	2.5” (~6,35 cm)	1.5” (~3,81 cm)
Shaft Diameter	1.5” (~3,81 cm)	1.5” (~3,81 cm)	0.75” (~1,91 cm)
Cylinder Configuration	Simple	Simple	Simple
Cylinder Action	Double	Double	Double
Material	Steel, Ductile iron	Steel, Ductile iron	Steel, Ductile iron
Mounting Method	Sleeve	Sleeve	Sleeve
Mount Location	Sleeve	Sleeve	End Cap
Cylinder Style	Welded	Welded	Welded

HYDRAULIC HOSE INFORMATION

Part Number	A3155	A3290	A3387	A7678-17	A7678-19	A7679-24
Description	Hose Assembly 3/8" x 28" (~71,12 cm)	Hose Assembly 3/8" x 98" (~248,92 cm)	Hose Assembly 3/4" X 100" ~(254,00 cm)	Hose Assembly 1/4" X 17" (~43,17 cm)	Hose Assembly 1/4" X 19" (~48,26 cm)	Hose Assembly 1/4" X 24" (~60,96 cm)
JIC Size*	06F - 06F	06F - 06F	12F - 12F	04F - 04F	04F - 04F	06F - 06F90
Product Category	Hydraulic Hose	Hydraulic Hose	Hydraulic Hose	Hydraulic Hose	Hydraulic Hose	Hydraulic Hose
Product Form	Hose; Assembly	Hose; Assembly	Hose; Assembly	Hose; Assembly	Hose; Assembly	Hose; Assembly
I.D.	3/8" (~9,53 mm)	3/8" (~9,53 mm)	3/4" (~19,05 mm)	1/4" (~6,35 mm)	1/4" (~6,35 mm)	1/4" (~6,35 mm)
O.D.	1 1/16" (~17,46 mm)	1 1/16" (~17,45 mm)	1 1/16" (~26,99 mm)	1/2" (~12,70 mm)	1/2" (~12,70 mm)	1/2" (~12,70 mm)
Minimum Bend Radius	2.5" (63,50 mm)	2.5" (63,50 mm)	4.75" (~120,65 mm)	2" (~50,80 mm)	2" (~50,80 mm)	2" (~50,80 mm)
Working Pressure	3000 PSI (~20700 kPa)	3000 PSI (~20700 kPa)	2250 PSI (~15500 kPa)	3000 PSI (~20700 kPa)	3000 PSI (~20700 kPa)	3000 PSI (~20700 kPa)
Temperature Range	-40°C - +100°C	-40°C - +100°C	-40°C - +100°C	-40°C - +100°C	-40°C - +100°C	-40°C - +100°C
Material	Modified Nitrile Type C2	Modified Nitrile Type C2	Modified Nitrile Type C2	Modified Nitrile Type C2	Modified Nitrile Type C2	Modified Nitrile Type C2
Specialized Construction	High Tensile Steel Wire	High Tensile Steel Wire	High Tensile Steel Wire	High Tensile Steel Wire	High Tensile Steel Wire	High Tensile Steel Wire
Media	Hydraulic Fluid	Hydraulic Fluid	Hydraulic Fluid	Hydraulic Fluid	Hydraulic Fluid	Hydraulic Fluid
Application	Agricultural and Construction	Agricultural and Construction	Agricultural; Construction	Agricultural and Construction	Agricultural and Construction	Agricultural and Construction
Part Number	A7677-24	A7678-43	A7679-32	A11810-102	A12011	A12701
Description	Hose Assembly 1/4" x 24" (~60,96 cm)	Hose Assembly 1/4" x 43" (~109,22 cm)	Hose Assembly 1/4" x 32" (~81,28 cm)	Hose Assembly 1 1/4" x 102" (~259,08 cm)	Hose Assembly 3/8" x 20" (~50,80 cm)	Hose Assembly 1/2" x 424" (~1076,96 cm)
JIC Size*	04F - 04F90	04F - 04F	04F - 06F90	20F - 20F	06F - 06F	08F - 08F
Product Category	Hydraulic Hose	Hydraulic Hose	Hydraulic Hose	Hydraulic Hose	Hydraulic Hose	Hydraulic Hose
Product Form	Hose; Assembly	Hose; Assembly	Hose; Assembly	Hose; Assembly	Hose; Assembly	Hose; Assembly
I.D.	1/4" (~6,35 mm)	1/4" (~6,35 mm)	1/4" (~6,35 mm)	1 1/4" (~31,75 mm)	3/8" (~9,53 mm)	1/2" (~12,70 mm)
O.D.	0.47" (~11,94 mm)	0.47" (~11,94 mm)	0.47" (~11,94 mm)	--	1 1/16" (~17,46 mm)	1 3/16" (~20,64 mm)
Minimum Bend Radius	2" (~50,80 mm)	2" (~50,80 mm)	2" (~50,80 mm)	8" (~203,20 mm)	2.5" (~63,50 mm)	3.5" (~88,90 mm)
Working Pressure	3000 PSI (~20680 kPa)	3000 PSI (~20680 kPa)	3000 PSI (~20680 kPa)	75 PSI (~520 kPa)	3000 PSI (~20680 kPa)	3000 PSI (~20680 kPa)
Temperature Range	-40°C - +100°C	-40°C - +100°C	-40°C - +100°C	-40°C - +100°C	-40°C - +100°C	-40°C - +100°C
Material	Modified Nitrile Type C2	Modified Nitrile Type C2	Modified Nitrile Type C2	Modified Nitrile Type C2	Modified Nitrile Type C2	Modified Nitrile Type C2
Specialized Construction	High Tensile Steel Wire	High Tensile Steel Wire	High Tensile Steel Wire	High Tensile Steel Wire	High Tensile Steel Wire	High Tensile Steel Wire
Media	Hydraulic Fluid	Hydraulic Fluid	Hydraulic Fluid	Hydraulic Fluid	Hydraulic Fluid	Hydraulic Fluid
Application	Agricultural and Construction	Agricultural and Construction	Agricultural and Construction	Agricultural; Construction	Agricultural; Construction	Agricultural; Construction

HYDRAULIC HOSE INFORMATION

Part Number	A12776	A12935-250	A12935-262	A12935-309	A15056	A15071-115
Description	Hose Assembly 1/2" x 252" (~640,08 cm)	Hose Assembly 3/4" x 250" (~635,00 cm)	Hose Assembly 3/4" x 262" (~665,48 cm)	Hose Assembly 3/4" x 309" (~784,86 cm)	Hose Assembly 3/8" x 40" (~101,60 cm)	Hose Assembly 3/8" x 115" (~292,10 cm)
JIC Size*	08F - 08F	08F - 08F	08F - 08F	08F - 08F	06F - 06F	06F - 06F
Product Category	Hydraulic Hose	Hydraulic Hose	Hydraulic Hose	Hydraulic Hose	Hydraulic Hose	Hydraulic Hose
Product Form	Hose; Assembly	Hose; Assembly	Hose; Assembly	Hose; Assembly	Hose; Assembly	Hose; Assembly
I.D.	1/2" (~12,70 mm)	3/4" (~19,05 mm)	3/4" (~19,05 mm)	3/4" (~19,05 mm)	3/8" (~9,53 mm)	3/8" (~9,53 mm)
O.D.	13/16" (~20,64 mm)	1 1/16" (~26,99 mm)	1 1/16" (~26,99 mm)	1 1/16" (~26,99 mm)	5/8" (~15,88 mm)	5/8" (~15,88 mm)
Minimum Bend Radius	3.5" (~88,90 mm)	4.75" (~120,65 mm)	4.75" (~120,65 mm)	4.75" (~120,65 mm)	2.5" (~63,50 mm)	2.5" (~63,50 mm)
Working Pressure	3000 PSI (~20680 kPa)	2250 PSI (~15500 kPa)	2250 PSI (~15500 kPa)	2250 PSI (~15500 kPa)	3000 PSI (~20680 kPa)	3000 PSI (~20680 kPa)
Temperature Range	-40°C - +100°C	-40°C - +100°C	-40°C - +100°C	-40°C - +100°C	-40°C - +100°C	-40°C - +100°C
Material	Modified Nitrile Type C2	Modified Nitrile Type C2	Modified Nitrile Type C2	Modified Nitrile Type C2	Modified Nitrile Type C2	Modified Nitrile Type C2
Specialized Construction	High Tensile Steel Wire	High Tensile Steel Wire	High Tensile Steel Wire	High Tensile Steel Wire	High Tensile Steel Wire	High Tensile Steel Wire
Media	Hydraulic Fluid	Hydraulic Fluid	Hydraulic Fluid	Hydraulic Fluid	Hydraulic Fluid	Hydraulic Fluid
Application	Agricultural; Construction	Agricultural; Construction	Agricultural; Construction	Agricultural; Construction	Agricultural; Construction	Agricultural; Construction
Part Number	A15072-118	A15079-256	A15080-38	A15081-37	A15081-103	A15081-128
Description	Hose Assembly 3/8" x 118" (~299,72 cm)	Hose Assembly 3/8" x 256" (~ 650,24 cm)	Hose Assembly 3/8" x 38" (~ 96,52 cm)	Hose Assembly 3/8" x 37" (~93,98 cm)	Hose Assembly 3/8" x 103" (~261,62 cm)	Hose Assembly 3/8" x 128" (~325,12 cm)
JIC Size*	06F90S - 06F	06F ST90-06F	06F - 06M	06F - 06F	06F - 06F	06F - 06F
Product Category	Hydraulic Hose	Hydraulic Hose	Hydraulic Hose	Hydraulic Hose	Hydraulic Hose	Hydraulic Hose
Product Form	Hose; Assembly	Hose; Assembly	Hose; Assembly	Hose; Assembly	Hose; Assembly	Hose; Assembly
I.D.	3/8" (~9,53 mm)	3/8" (~9,53 mm)	3/8" (~9,53 mm)	3/8" (~9,53 mm)	3/8" (~9,53 mm)	3/8" (~9,53 mm)
O.D.	5/8" (~15,88mm)	5/8" (~15,88mm)	5/8" (~15,88mm)	5/8" (~15,88mm)	5/8" (~15,88mm)	5/8" (~15,88mm)
Minimum Bend Radius	2.5" (63,50 mm)	2.5" (63,50 mm)	2.5" (63,50 mm)	2.5" (63,50 mm)	2.5" (63,50 mm)	2.5" (63,50 mm)
Working Pressure	3000 PSI (~20680 kPa)	3000 PSI (~20680 kPa)	3000 PSI (~20680 kPa)	3000 PSI (~20680 kPa)	3000 PSI (~20680 kPa)	3000 PSI (~20680 kPa)
Temperature Range	-40°C - +100°C	-40°C - +100°C	-40°C - +100°C	-40°C - +100°C	-40°C - +100°C	-40°C - +100°C
Material	Modified Nitrile Type C2	Modified Nitrile Type C2	Modified Nitrile Type C2	Modified Nitrile Type C2	Modified Nitrile Type C2	Modified Nitrile Type C2
Specialized Construction	High Tensile Steel Wire	High Tensile Steel Wire	High Tensile Steel Wire	High Tensile Steel Wire	High Tensile Steel Wire	High Tensile Steel Wire
Media	Hydraulic Fluid	Hydraulic Fluid	Hydraulic Fluid	Hydraulic Fluid	Hydraulic Fluid	Hydraulic Fluid
Application	Agricultural; Construction	Agricultural; Construction	Agricultural; Construction	Agricultural; Construction	Agricultural; Construction	Agricultural; Construction

HYDRAULIC HOSE INFORMATION

Part Number	A15081-148	A15081-205	A15081-248	A15081-295	A15081-310	A15081-365
Description	Hose Assembly 3/8" x 148" (~375,92 cm)	Hose Assembly 3/8" x 205" (~520,70 cm)	Hose Assembly 3/8" x 248" (~629,62 cm)	Hose Assembly 3/8" x 295" (~749,30 cm)	Hose Assembly 3/8" x 310" (787,40 cm)	Hose Assembly 3/8" x 365 (~927,10 cm)
JIC Size*	06F - 06F	06F - 06F	06F - 06F	06F - 06F	06F - 06F	06F - 06F
Product Category	Hydraulic Hose	Hydraulic Hose	Hydraulic Hose	Hydraulic Hose	Hydraulic Hose	Hydraulic Hose
Product Form	Hose; Assembly	Hose; Assembly	Hose; Assembly	Hose; Assembly	Hose; Assembly	Hose; Assembly
I.D.	3/8" (~9,53 mm)	3/8" (~9,53 mm)	3/8" (~9,53 mm)	3/8" (9,5 mm)	3/8" (~9,53 mm)	3/8" (~9,53 mm)
O.D.	5/8" (~15,88 mm)	5/8" (~15,88 mm)	5/8" (~15,88 mm)	5/8" (~15,88 mm)	5/8" (~15,88 mm)	5/8" (~15,88 mm)
Minimum Bend Radius	2.5" (~63,50 mm)	2.5" (~63,50 mm)	2.5" (~63,50 mm)	2.5" (~63,50 mm)	2.5" (~63,50 mm)	2.5" (~63,50 mm)
Working Pressure	3000 PSI (~20680 kPa)	3000 PSI (~20680 kPa)	3000 PSI (~20680 kPa)	3000 PSI (~20680 kPa)	3000 PSI (~20680 kPa)	3000 PSI (~20680 kPa)
Temperature Range	-40°C - +100°C	-40°C - +100°C	-40°C - +100°C	-40°C - +100°C	-40°C - +100°C	-40°C - +100°C
Material	Modified Nitrile Type C2	Modified Nitrile Type C2	Modified Nitrile Type C2	Modified Nitrile Type C2	Modified Nitrile Type C2	Modified Nitrile Type C2
Specialized Construction	High Tensile Steel Wire	High Tensile Steel Wire	High Tensile Steel Wire	High Tensile Steel Wire	High Tensile Steel Wire	High Tensile Steel Wire
Media	Hydraulic Fluid	Hydraulic Fluid	Hydraulic Fluid	Hydraulic Fluid	Hydraulic Fluid	Hydraulic Fluid
Application	Agricultural; Construction	Agricultural; Construction	Agricultural; Construction	Agricultural; Construction	Agricultural; Construction	Agricultural; Construction

Part Number	A15092-18	A15092-21	A15092-74	A15092-77	A15096-16	A15098-254
Description	Hose Assembly 3/8" x 18" (~45,72 cm)	Hose Assembly 3/8" x 21" (~53,34 cm)	Hose Assembly 3/8" x 74" (~187,96 cm)	Hose Assembly 3/8" x 77" (~195,58 cm)	Hose Assembly 3/8" x 16 (~40,64 cm)	Hose Assembly 3/8" x 254" (~645,16 cm)
JIC Size*	06F - 08F	06F - 08F	06F - 08F	06F - 08F	06F - 06F90S	10F - 08M
Product Category	Hydraulic Hose	Hydraulic Hose	Hydraulic Hose	Hydraulic Hose	Hydraulic Hose	Hydraulic Hose
Product Form	Hose; Assembly	Hose; Assembly	Hose; Assembly	Hose; Assembly	Hose; Assembly	Hose; Assembly
I.D.	3/8" (~9,53 mm)	3/8" (~9,53 mm)	3/8" (~9,53 mm)	3/8" (~9,53 mm)	3/8" (~9,53 mm)	3/8" (~9,53 mm)
O.D.	5/8" (~15,88 mm)	5/8" (~15,88 mm)	5/8" (~15,88 mm)	5/8" (~15,88 mm)	5/8" (~15,88 mm)	5/8" (~15,88 mm)
Minimum Bend Radius	2.5" (~63,50 mm)	2.5" (~63,50 mm)	2.5" (~63,50 mm)	2.5" (~63,50 mm)	2.5" (~63,50 mm)	2.5" (~63,50 mm)
Working Pressure	3000 PSI (~20680 kPa)	3000 PSI (~20680 kPa)	3000 PSI (~20680 kPa)	3000 PSI (~20680 kPa)	3000 PSI (~20680 kPa)	3000 PSI (~20680 kPa)
Temperature Range	-40°C - +100°C	-40°C - +100°C	-40°C - +100°C	-40°C - +100°C	-40°C - +100°C	-40°C - +100°C
Material	Modified Nitrile Type C2	Modified Nitrile Type C2	Modified Nitrile Type C2	Modified Nitrile Type C2	Modified Nitrile Type C2	Modified Nitrile Type C2
Specialized Construction	High Tensile Steel Wire	High Tensile Steel Wire	High Tensile Steel Wire	High Tensile Steel Wire	High Tensile Steel Wire	High Tensile Steel Wire
Media	Hydraulic Fluid	Hydraulic Fluid	Hydraulic Fluid	Hydraulic Fluid	Hydraulic Fluid	Hydraulic Fluid
Application	Agricultural; Construction	Agricultural; Construction	Agricultural; Construction	Agricultural; Construction	Agricultural; Construction	Agricultural; Construction

HYDRAULIC HOSE INFORMATION

Part Number	A18666-390	A18667-41	A18667-53	A18667-88	A18667-200	A18667-215
Description	Hose Assembly 1/2" x 390" (~990,60 cm)	Hose Assembly 1/2" x 41" (~104,14 cm)	Hose Assembly 1/2" x 53" (~134,62 cm)	Hose Assembly 1/2" x 88" (~223,52 cm)	Hose Assembly 1/2" x 200" (~508,00 cm)	Hose Assembly 1/2" x 215" (~546,10 cm)
JIC Size*	10F - 10F	08F - 08F	08F - 08F	08F - 08F	08F - 08F	08F - 08F
Product Category	Hydraulic Hose	Hydraulic Hose	Hydraulic Hose	Hydraulic Hose	Hydraulic Hose	Hydraulic Hose
Product Form	Hose; Assembly	Hose; Assembly	Hose; Assembly	Hose; Assembly	Hose; Assembly	Hose; Assembly
I.D.	1/2" (~12,70 mm)	1/2" (~12,70 mm)	1/2" (~12,70 mm)	1/2" (~12,70 mm)	1/2" (~12,70 mm)	1/2" (~12,70 mm)
O.D.	13/16" (20,64 mm)	13/16" (20,64 mm)	13/16" (20,64 mm)	13/16" (20,64 mm)	13/16" (20,64 mm)	13/16" (20,64 mm)
Minimum Bend Radius	3.5" (~88,90 mm)	3.5" (~88,90 mm)	3.5" (~88,90 mm)	3.5" (~88,90 mm)	3.5" (~88,90 mm)	3.5" (~88,90 mm)
Working Pressure	3000 PSI (~20680 kPa)	3000 PSI (~20680 kPa)	3000 PSI (~20680 kPa)	3000 PSI (~20680 kPa)	3000 PSI (~20680 kPa)	3000 PSI (~20680 kPa)
Temperature Range	-40°C - +100°C	-40°C - +100°C	-40°C - +100°C	-40°C - +100°C	-40°C - +100°C	-40°C - +100°C
Material	Modified Nitrile Type C2	Modified Nitrile Type C2	Modified Nitrile Type C2	Modified Nitrile Type C2	Modified Nitrile Type C2	Modified Nitrile Type C2
Specialized Construction	High Tensile Steel Wire	High Tensile Steel Wire	High Tensile Steel Wire	High Tensile Steel Wire	High Tensile Steel Wire	High Tensile Steel Wire
Media	Hydraulic Fluid	Hydraulic Fluid	Hydraulic Fluid	Hydraulic Fluid	Hydraulic Fluid	Hydraulic Fluid
Application	Agricultural; Construction	Agricultural; Construction	Agricultural; Construction	Agricultural; Construction	Agricultural; Construction	Agricultural; Construction
Part Number	A18670-128	A18670-242	A18670-254	A18671-16	A18671-482	A18673-115
Description	Hose Assembly 1/2" x 128" (~325,12 cm)	Hose Assembly 1/2" x 242" (~614,68 cm)	Hose Assembly 1/2" x 254" (~645,16 cm)	Hose Assembly 1/2" x 16" (~40,64 cm)	Hose Assembly 1/2" x 482" (~1224,28 cm)	Hose Assembly 1/2" x 115" (~292,10 cm)
JIC Size	08F - 08M	08F - 08M	08F - 08M	08F - 08F90	08F - 08F90	1/2 NPTF - 08F
Product Category	Hydraulic Hose	Hydraulic Hose	Hydraulic Hose	Hydraulic Hose	Hydraulic Hose	Hydraulic Hose
Product Form	Hose; Assembly	Hose; Assembly	Hose; Assembly	Hose; Assembly	Hose; Assembly	Hose; Assembly
I.D.	1/2" (~12,70 mm)	1/2" (~12,70 mm)	1/2" (~12,70 mm)	1/2" (~12,70 mm)	1/2" (~12,70 mm)	1/2" (~12,70 mm)
O.D.	13/16" (20,64 mm)	13/16" (20,64 mm)	13/16" (20,64 mm)	13/16" (20,64 mm)	13/16" (20,64 mm)	13/16" (20,64 mm)
Minimum Bend Radius	3.5" (~88,90 mm)	3.5" (~88,90 mm)	3.5" (~88,90 mm)	3.5" (~88,90 mm)	3.5" (~88,90 mm)	3.5" (~88,90 mm)
Working Pressure	3000 PSI (~20680 kPa)	3000 PSI (~20680 kPa)	3000 PSI (~20680 kPa)	3000 PSI (~20680 Pa)	3000 PSI (~20680 kPa)	3000 PSI (~20680 kPa)
Temperature Range	-40°C - +100°C	-40°C - +100°C	-40°C - +100°C	-40°C - +100°C	-40°C - +100°C	-40°C - +100°C
Material	Modified Nitrile Type C2	Modified Nitrile Type C2	Modified Nitrile Type C2	Modified Nitrile Type C2	Modified Nitrile Type C2	Modified Nitrile Type C2
Specialized Construction	High Tensile Steel Wire	High Tensile Steel Wire	High Tensile Steel Wire	High Tensile Steel Wire	High Tensile Steel Wire	High Tensile Steel Wire
Media	Hydraulic Fluid	Hydraulic Fluid	Hydraulic Fluid	Hydraulic Fluid	Hydraulic Fluid	Hydraulic Fluid
Application	Agricultural; Construction	Agricultural; Construction	Agricultural; Construction	Agricultural; Construction	Agricultural; Construction	Agricultural and Construction

HYDRAULIC HOSE INFORMATION

Part Number	A18674-36	A18674-415	A18671-482	A18673-115	A18674-36	A18674-415
Description	Hose Assembly 1/2" x 36" (~91,44 cm)	Hose Assembly 1/2" x 415" (~1054,10 cm)	Hose Assembly 1/2" x 482" (~1224,28 cm)	Hose Assembly 1/2" x 115" (~292,10 cm)	Hose Assembly 1/2" x 36" (~91,44 cm)	Hose Assembly 1/2" x 415" (~1054,10 cm)
JIC Size*	08F - 08F90	08F - 08F90	08F - 08F90	1/2 NPTF 08M - 12F	08F - 08F90	08F - 08F90
Product Category	Hydraulic Hose	Hydraulic Hose	Hydraulic Hose	Hydraulic Hose	Hydraulic Hose	Hydraulic Hose
Product Form	Hose; Assembly	Hose; Assembly	Hose; Assembly	Hose; Assembly	Hose; Assembly	Hose; Assembly
I.D.	1/2" (~12,70 mm)	1/2" (~12,70 mm)	1/2" (~12,70 mm)	1/2" (~12,70 mm)	1/2" (~12,70 mm)	1/2" (~12,70 mm)
O.D.	13/16" (~20,64 mm)	13/16" (~20,64 mm)	0.78" (~19,81 mm)	0.78" (~19,81 mm)	13/16" (~20,64 mm)	13/16" (~20,64 mm)
Minimum Bend Radius	3.5" (89 mm)	3.5" (89 mm)	3.5" (89 mm)	3.5" (89 mm)	3.5" (89 mm)	3.5" (89 mm)
Working Pressure	2750 PSI (~19000 kPa)	2750 PSI (~19000 kPa)	3000 PSI (~20680 kPa)	3000 PSI (~20680 kPa)	2750 PSI (~19000 kPa)	2750 PSI (~19000 kPa)
Temperature Range	-40°C - +100°C	-40°C - +100°C	-40°C - +100°C	-40°C - +100°C	-40°C - +100°C	-40°C - +100°C
Material	Modified Nitrile Type C2	Modified Nitrile Type C2	Modified Nitrile Type C2	Modified Nitrile Type C2	Modified Nitrile Type C2	Modified Nitrile Type C2
Specialized Construction	High Tensile Steel Wire	High Tensile Steel Wire	High Tensile Steel Wire	High Tensile Steel Wire	High Tensile Steel Wire	High Tensile Steel Wire
Media	Hydraulic Fluid	Hydraulic Fluid	Hydraulic Fluid	Hydraulic Fluid	Hydraulic Fluid	Hydraulic Fluid
Application	Agricultural; Construction	Agricultural; Construction	Agricultural; Construction	Agricultural; Construction	Agricultural; Construction	Agricultural; Construction
Part Number	A21525-254	A21526-114	A21530-200	A21530-203	A21530-217	A21530-296
Description	Hose Assembly 5/8" x 254" (~645,16 cm)	Hose Assembly 5/8" x 114 (~289,56 cm)	Hose Assembly 5/8" x 200" (~508,00 cm)	Hose Assembly 5/8" x 203" (~515,62 cm)	Hose Assembly 5/8" x 217" (~551,18 cm)	Hose Assembly 5/8" x 296" (~751,84 cm)
JIC Size*	10F - 10M	1/2NPTF 08M- 14F	10F - 10F	10F - 10F	10F - 10F	10F - 10F
Product Category	Hydraulic Hose	Hydraulic Hose	Hydraulic Hose	Hydraulic Hose	Hydraulic Hose	Hydraulic Hose
Product Form	Hose; Assembly	Hose; Assembly	Hose; Assembly	Hose; Assembly	Hose; Assembly	Hose; Assembly
I.D.	5/8" (~15,88 mm)	5/8" (~15,88 mm)	5/8" (~15,88 mm)	5/8" (~15,88 mm)	5/8" (~15,88 mm)	5/8" (~15,88 mm)
O.D.	15/16" (~23,81 mm)	15/16" (~23,81 mm)	15/16" (~23,81 mm)	15/16" (~23,81 mm)	15/16" (~23,81 mm)	15/16" (~23,81 mm)
Minimum Bend Radius	4" (~101,6 mm)	4" (~101,6 mm)	4" (~101,6 mm)	4" (~101,6 mm)	4" (~101,6 mm)	4" (~101,6 mm)
Working Pressure	2750 PSI (~19000 kPa)	2750 PSI (~19000 kPa)	2750 PSI (~19000 kPa)	2750 PSI (~19000 kPa)	2750 PSI (~19000 kPa)	2750 PSI (~19000 kPa)
Temperature Range	-40°C - +100°C	-40°C - +100°C	-40°C - +100°C	-40°C - +100°C	-40°C - +100°C	-40°C - +100°C
Material	Modified Nitrile Type C2	Modified Nitrile Type C2	Modified Nitrile Type C2	Modified Nitrile Type C2	Modified Nitrile Type C2	Modified Nitrile Type C2
Specialized Construction	High Tensile Steel Wire	High Tensile Steel Wire	High Tensile Steel Wire	High Tensile Steel Wire	High Tensile Steel Wire	High Tensile Steel Wire
Media	Hydraulic Fluid	Hydraulic Fluid	Hydraulic Fluid	Hydraulic Fluid	Hydraulic Fluid	Hydraulic Fluid
Application	Agricultural; Construction	Agricultural; Construction	Agricultural; Construction	Agricultural; Construction	Agricultural; Construction	Agricultural; Construction

HYDRAULIC HOSE INFORMATION

Part Number	A21533-13.5	A21533-26	A21533-30	A11481-217	A11481-284	A11482-30
Description	Hose Assembly 3/4" x 13.5" (~34,29 cm)	Hose Assembly 3/4" x 26" (~ 66,04 cm)	Hose Assembly 3/4" x 30" (~76,20 cm)	Hose Assembly 5/8" x 217" (551,18 cm)	Hose Assembly 5/8" x 284" (721,36 cm)	Hose Assembly 5/8" x 30" (76,20 cm)
JIC Size*	12F - 12F	12F - 12F	12F - 12F	10F - 10F	10F - 10F	10F - 12F
Product Category	Hydraulic Hose	Hydraulic Hose	Hydraulic Hose	Hydraulic Hose	Hydraulic Hose	Hydraulic Hose
Product Form	Hose; Assembly	Hose; Assembly	Hose; Assembly	Hose; Assembly	Hose; Assembly	Hose; Assembly
I.D.	3/4" (~19,05 mm)	3/4" (~19,05 mm)	3/4" (~19,05 mm)	5/8" (~15,88 mm)	5/8" (~15,88 mm)	5/8" (~15,88 mm)
O.D.	1 1/16" (~26,99 mm)	1 1/16" (~26,99 mm)	1 1/16" (~26,99 mm)	15/16" (~23,81 mm)	15/16" (~23,81 mm)	15/16" (~23,81 mm)
Minimum Bend Radius	4.75" (~120,65 mm)	4.75" (~120,65 mm)	4.75" (~120,65 mm)	4" (~101,60 mm)	4" (~101,60 mm)	4" (~101,60 mm)
Working Pressure	2250 PSI (~15500 kPa)	2250 PSI (~15500 kPa)	2250 PSI (~15500 kPa)	2750 PSI (~18960 kPa)	2750 PSI (~18960 kPa)	2750 PSI (~18960 kPa)
Temperature Range	-40°C - +100°C	-40°C - +100°C	-40°C - +100°C	-40°C - +100°C	-40°C - +100°C	-40°C - +100°C
Material	Modified Nitrile Type C2	Modified Nitrile Type C2	Modified Nitrile Type C2	Modified Nitrile Type C2	Modified Nitrile Type C2	Modified Nitrile Type C2
Specialized Construction	High Tensile Steel Wire	High Tensile Steel Wire	High Tensile Steel Wire	High Tensile Steel Wire	High Tensile Steel Wire	High Tensile Steel Wire
Media	Hydraulic Fluid	Hydraulic Fluid	Hydraulic Fluid	Hydraulic Fluid	Hydraulic Fluid	Hydraulic Fluid
Application	Agricultural; Construction	Agricultural; Construction	Agricultural; Construction	Agricultural; Construction	Agricultural; Construction	Agricultural; Construction
Part Number	A18629-390	A18629-88	A18630-215	A18630-240	A18678-102	A18678-120
Description	Hose Assembly 1/2" x 390" (~990,60 cm)	Hose Assembly 1/2" x 88" (~223,52 cm)	Hose Assembly 1/2" x 88" (~223,52 cm)	Hose Assembly 1/2" x 240" (~609,60 cm)	Hose Assembly 1/2" x 102" (~259,08 cm)	Hose Assembly 1/2" x 240" (~609,60 cm)
JIC Size*	10F - 10F	10F - 10F	08F - 08F	08F - 08F	08F - 12F	08F - 12F
Product Category	Hydraulic Hose	Hydraulic Hose	Hydraulic Hose	Hydraulic Hose	Hydraulic Hose	Hydraulic Hose
Product Form	Hose; Assembly	Hose; Assembly	Hose; Assembly	Hose; Assembly	Hose; Assembly	Hose; Assembly
I.D.	1/2" (~12,70 mm)	1/2" (~12,70 mm)	1/2" (~12,70 mm)	1/2" (~12,70 mm)	1/2" (~12,70 mm)	1/2" (~12,70 mm)
O.D.	13/16" (20,64 mm)	13/16" (20,64 mm)	13/16" (20,64 mm)	13/16" (20,64 mm)	13/16" (20,64 mm)	13/16" (20,64 mm)
Minimum Bend Radius	3.5" (~88,90 mm)	3.5" (~88,90 mm)	3.5" (~88,90 mm)	3.5" (~88,90 mm)	3.5" (~88,90 mm)	3.5" (~88,90 mm)
Working Pressure	2750 PSI (~18960 kPa)	2750 PSI (~18960 kPa)	3000 PSI (~20680 kPa)	3000 PSI (~20680 kPa)	3000 PSI (~20680 kPa)	3000 PSI (~20680 kPa)
Temperature Range	-40°C - +100°C	-40°C - +100°C	-40°C - +100°C	-40°C - +100°C	-40°C - +100°C	-40°C - +100°C
Material	Modified Nitrile Type C2	Modified Nitrile Type C2	Modified Nitrile Type C2	Modified Nitrile Type C2	Modified Nitrile Type C2	Modified Nitrile Type C2
Specialized Construction	High Tensile Steel Wire	High Tensile Steel Wire	High Tensile Steel Wire	High Tensile Steel Wire	High Tensile Steel Wire	High Tensile Steel Wire
Media	Hydraulic Fluid	Hydraulic Fluid	Hydraulic Fluid	Hydraulic Fluid	Hydraulic Fluid	Hydraulic Fluid
Application	Agricultural; Construction	Agricultural; Construction	Agricultural; Construction	Agricultural; Construction	Agricultural; Construction	Agricultural; Construction

HYDRAULIC HOSE INFORMATION







Part Number	A18686-482	A21525-12	A21533-13.5	A21534-114	A21536-242	A25704-128
Description	Hose Assembly ½" x 482" (~1224,28 cm)	Hose Assembly 5/8" x 12" (~30,48 cm)	Hose Assembly ¾" x 13.5" (~34,29 cm)	Hose Assembly 5/8" x 114" (~289,56 cm)	Hose Assembly 5/8" x 242" (~614,68 cm)	Hose Assembly ½" x 128" (~325,12 cm)
JIC Size*	08F - 08F90S	12F - 14M	12F - 12F	½ NPTF - 10F	10F - 10M	08F - 08M
Product Category	Hydraulic Hose	Hydraulic Hose	Hydraulic Hose	Hydraulic Hose	Hydraulic Hose	Hydraulic Hose
Product Form	Hose; Assembly	Hose; Assembly	Hose; Assembly	Hose; Assembly	Hose; Assembly	Hose; Assembly
I.D.	½" (~12,70 mm)	5/8" (~15,88 mm)	¾" (~19,05 mm)	5/8" (~15,88 mm)	5/8" (~15,88 mm)	½" (~12,70 mm)
O.D.	0.78" (~19,81 mm)	15/16" (~23,81 mm)	1 1/16" (~26,99 mm)	15/16" (~23,81 mm)	15/16" (~23,81 mm)	13/16" (~20,64 mm)
Minimum Bend Radius	3.5" (88,90 mm)	4" (~101,60 mm)	4.75" (~120,65 mm)	4" (~101,60 mm)	4" (~101,60 mm)	3.5" (89,00 mm)
Working Pressure	3000 PSI (~20680 kPa)	2750 PSI (~18960 kPa)	2250 PSI (~15500 kPa)	2750 PSI (~19000 kPa)	2750 PSI (~19000 kPa)	3000 PSI (~20680 kPa)
Temperature Range	-40°C - +100°C	-40°C - +100°C	-40°C - +100°C	-40°C - +100°C	-40°C - +100°C	-40°C - +100°C
Material	Modified Nitrile Type C2	Modified Nitrile Type C2	Modified Nitrile Type C2	Modified Nitrile Type C2	Modified Nitrile Type C2	Modified Nitrile Type C2
Specialized Construction	High Tensile Steel Wire	High Tensile Steel Wire	High Tensile Steel Wire	High Tensile Steel Wire	High Tensile Steel Wire	High Tensile Steel Wire
Media	Hydraulic Fluid	Hydraulic Fluid	Hydraulic Fluid	Hydraulic Fluid	Hydraulic Fluid	Hydraulic Fluid
Application	Agricultural; Construction	Agricultural; Construction	Agricultural; Construction	Agricultural; Construction	Agricultural; Construction	Agricultural; Construction
Part Number	A25691-148	A25961-248	A25691-287	A25691-98	A25695-115	A25703-115
Description	Hose Assembly .375" x 148" (~375,92 cm)	Hose Assembly .375" x 248" (~629,92 cm)	Hose Assembly .375" x 287" (~728,98 cm)	Hose Assembly .375" x 98" (~248,92 cm)	Hose Assembly .375" x 115" (~292,10 cm)	Hose Assembly ½" x 115" (~292,10 cm)
JIC Size*	06F - 06F	06F - 06F	06F - 06F	06F - 06F	½"NPTF - 06F	½"NPTF - 08F
Product Category	Hydraulic Hose	Hydraulic Hose	Hydraulic Hose	Hydraulic Hose	Hydraulic Hose	Hydraulic Hose
Product Form	Hose; Assembly	Hose; Assembly	Hose; Assembly	Hose; Assembly	Hose; Assembly	Hose; Assembly
I.D.	.375" (~9,53 mm)	.375" (~9,53 mm)	.375" (~9,53 mm)	.375" (~9,53 mm)	.375" (~9,53 mm)	½" (~12,70 mm)
O.D.	.62" (~15,75 mm)	.62" (~15,75 mm)	.62" (~15,75 mm)	.62" (~15,75 mm)	.62" (~15,75 mm)	.78" (~19,81 mm)
Minimum Bend Radius	2.5" (~63,50 mm)	2.5" (~63,50 mm)	2.5" (~63,50 mm)	2.5" (~63,50 mm)	2.5" (~63,50 mm)	3.5" (~88,90 mm)
Working Pressure	3000 PSI (~20680 kPa)	3000 PSI (~20680 kPa)	3000 PSI (~20680 kPa)	3000 PSI (~20680 kPa)	3000 PSI (~20680 kPa)	3000 PSI (~20680 kPa)
Temperature Range	-40°C - +100°C	-40°C - +100°C	-40°C - +100°C	-40°C - +100°C	-40°C - +100°C	-40°C - +100°C
Material	Modified Nitrile Type C2	Modified Nitrile Type C2	Modified Nitrile Type C2	Modified Nitrile Type C2	Modified Nitrile Type C2	Modified Nitrile Type C2
Specialized Construction	High Tensile Steel Wire	High Tensile Steel Wire	High Tensile Steel Wire	High Tensile Steel Wire	High Tensile Steel Wire	High Tensile Steel Wire
Media	Hydraulic Fluid	Hydraulic Fluid	Hydraulic Fluid	Hydraulic Fluid	Hydraulic Fluid	Hydraulic Fluid
Application	Agricultural; Construction	Agricultural; Construction	Agricultural; Construction	Agricultural; Construction	Agricultural; Construction	Agricultural; Construction

HYDRAULIC HOSE INFORMATION

Part Number	A25704-128	A25704-242				
Description	Hose Assembly 1/2" x 128" (~325,12 cm)	Hose Assembly 1/2" x 242" (~614,68 cm)				
JIC Size*	08F - 08M	08F - 08M				
Product Category	Hydraulic Hose	Hydraulic Hose				
Product Form	Hose; Assembly	Hose; Assembly				
I.D.	1/2" (~12,70 mm)	1/2" (~12,70 mm)				
O.D.	13/16" (~20,64 mm)	13/16" (~20,64 mm)				
Minimum Bend Radius	3.5" (89,00 mm)	3.5" (89,00 mm)				
Working Pressure	3000 PSI (~20680 kPa)	3000 PSI (~20680 kPa)				
Temperature Range	-40°C - +100°C	-40°C - +100°C				
Material	Modified Nitrile Type C2	Modified Nitrile Type C2				
Specialized Construction	High Tensile Steel Wire	High Tensile Steel Wire				
Media	Hydraulic Fluid	Hydraulic Fluid				
Application	Agricultural; Construction	Agricultural; Construction				

This page intentionally left blank.

TRANSPORTING PLANTER

- | | |
|---|--|
|  WARNING
 | <p>Uncontrolled movement of equipment can cause loss of control and could result in death, serious injury, or damage to property and equipment. Install all safety pins before transporting equipment.</p> |
|  WARNING
 | <p>Uncontrolled machine movement can crush or cause loss of control resulting in death, serious injury, or damage to property and equipment. Install all safety lockup devices before working under or transporting this equipment.</p> |
|  WARNING | <p>Transporting planter with hoppers over half full or unevenly loaded can cause loss of control and could result in death, serious injury, or damage to property and equipment. Properly load planter when transporting. Be aware of extra transport weight, and road conditions and limits.</p> |
|  WARNING | <p>To avoid unintended movement of axle during transport, return all SCV controls to the neutral position before transporting machine. DO NOT operate any hydraulic function while transporting machine. Doing so could result in death, serious injury, or damage to property and equipment.</p> |
|  WARNING | <p>Transport axle can lower from transport position without the use of any controller, causing death, serious injury, or damage to property and equipment. Do not operate any hydraulic function while transporting the planter. Make sure all transport safety lockups are installed on the four transport cylinders and all SCV controls are in their neutral state before transporting, storing and working on the planter.</p> |

Make sure safety/warning lights, reflective decals, and SMV sign are in place and visible before transporting machine on public roads. It is your responsibility to check and comply with all federal, state/provincial, and local regulations. Be aware of road and bridge weight limits. Allow for additional weight of added options and any additional material or substances that have been added to the machine.

LEVEL PLANTER

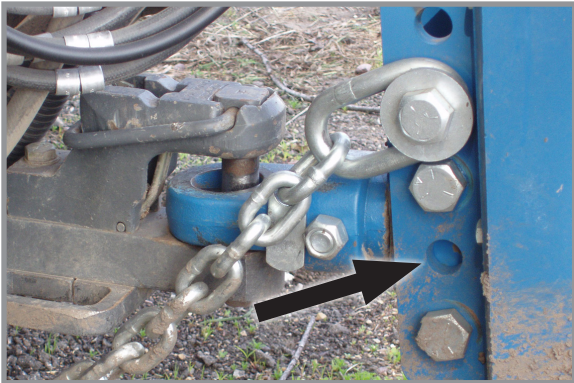

Clevis Adjustment Holes

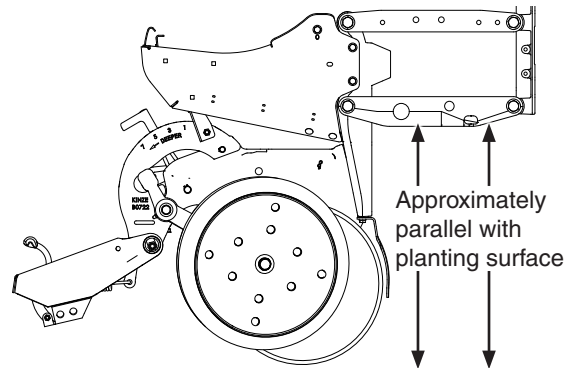

Level Row Units

Toolbar should operate at 23"-25" (~58 - 63 cm) height from planting surface. Tire pressures must be maintained at pressures specified for planter to operate level laterally. Check toolbar and row unit parallel arms are level front to back with planter lowered to proper operating height.

Field and actual planting conditions determine which wheel settings to use to ensure row unit parallel arms are approximately parallel with planting surface. If planting in extremely soft soil conditions it may be necessary to move ground drive tires to lower sets of mounting holes. To allow adequate drive force after lowering the ground drive tires, it may be necessary to lower contact drive arms to lower set of holes in wheel module and relocate down pressure springs to lower mounting rod on wheel module.

If planter center is higher or lower than wings after rephasing, contact your Kinze Dealer for valve adjustment or maintenance.

JUMP START SENSOR

The jump start sensor is intended to reduce the seed gap when starting from a stop with the planter in the ground. For the jump start sensor to work as intended, the planter speed sensor needs to be set within $\frac{1}{8}$ " (~0,3 cm) of the pick-up disc. The planter speed sensor also needs to be calibrated properly and have the speed source set to automatic. Refer to Kinze ISOBUS Operator's Manual (M0246) for calibration instructions.

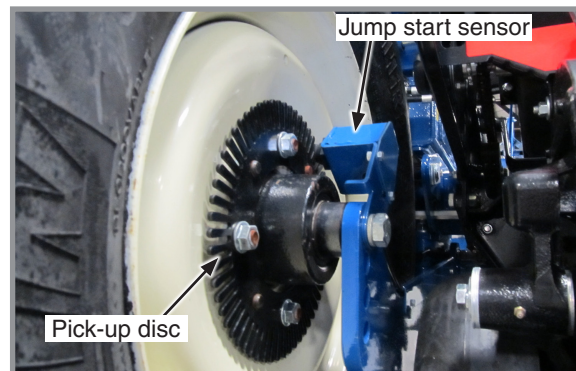

Jump Start Sensor and Pick-up Disc

If the planter speed sensor is set-up properly, the start-up gap should be no more than 4 feet (~1,2 m).

If no gap is desired, there are two options for eliminating the gap completely:

1. Use the jump start button available on the ISOBUS display. Pressing this button will start turning the drives. Once a speed source is acquired, it will take over control. Refer to the ISOBUS manual (M0246) for further instructions on the jump start button.
2. Pick the planter up, back up 10 - 12 feet (~3 - 3,6 m), set the planter down and resume planting. The section control will turn the drives on at the correct time.

AG LEADER INCOMMAND 1200 DISPLAY

The InCommand 1200 is a full-featured display for any precision farming operation. A large, full-color 12.1" HD touchscreen display is easy to read and offers powerful, year-round precision farming tools. Mapping, planter and application control, yield monitoring, real-time data logging, and more – are all controlled from the cab using the InCommand display.

Four video camera inputs provide operators a better view of equipment operation and safety by allowing them to view live video on the display.

NOTE: See InCommand operator manual for installation and programming.



Ag Leader InCommand Display

KINZE BLUE VANTAGE®

Blue Vantage® can be ready to plant in three taps after proper setup. The health screen provides all critical planting parameters and controls. The grower can observe row-by-row planting performance in real-time.

NOTE: See Kinze Blue Vantage® Operator's Manual for system operation and programming.



Kinze Blue Vantage®

FIELD OPERATION

Planters are designed to operate within a speed range of 3 - 13 km/h. Higher ground speeds can cause more variation in seed spacing. Speeds above 10 km/h are typically not recommended.

NOTICE

Always raise planter out of ground when making sharp turns or backing up.

Normal field planting operation requires use of tractor's hydraulic control to raise and lower planter frame when making field turnarounds.

NOTICE

Operate row markers in float position to prevent damage to row markers.

Operate row markers with Blue Vantage or tractor's hydraulic control. After markers are lowered to ground, move hydraulic control to operate markers in float position. Marker speed is controlled with flow control valves located in planter left hand wing block. One valve controls raise speed and other valve controls lower speed of both markers. See ["Row Marker Speed Adjustment"](#) on page 2-34 and ["Row Marker Cable Adjustment"](#) on page 2-36.

TRANSPORT TO FIELD SEQUENCE USING KINZE BLUE VANTAGE® SYSTEM

NOTE: Refer to the Blue Vantage® (M0288) manual for more information.

TRANSPORT TO FIELD SEQUENCE USING CONTROL BOX (AGLEADER)

Position planter in a relatively flat open area without furrows, etc.

NOTICE

It is critically important to follow the fold and unfold sequence to avoid possible significant damage to the planter.

SUMMARIZED TRANSPORT TO FIELD SEQUENCE USING CONTROL BOX

NOTICE

Tractor must be in neutral and allowed to roll freely when unfolding to prevent equipment damage, especially in soft conditions. Use tractor assist as needed to aid in unfolding and to reduce stress on frame and transport components.

1. Remove lockups.
2. Place function switch on control box in FOLD position.
3. Lower transport axle into field turnaround position.
4. Lower hitch to its lowest position.
5. Disengage wing hooks.
6. Fold wings outward until stub wing latch pins are sealed into H-frame receivers.
7. Lower planter and hold hydraulic lever until toolbar is level.
8. Raise hitch to level machine during planting.

NOTE: Read following information for detailed instructions.

NOTICE

DO NOT fold or unfold planter without planter attached to a tractor. DO NOT unhitch planter from tractor unless fully folded for transport or fully unfolded with planting units lowered to ground.

NOTICE

When adjusting vacuum fans with the control box, always allow a few seconds for the vacuum to adjust after each click.

1. Remove and store locking pin on drawbar hitch.
Remove lockups.

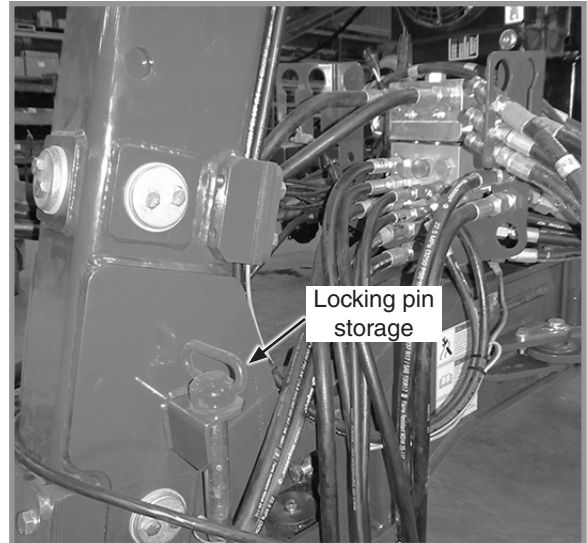

Locking Pin for Drawbar Hitch

2. Place FUNCTION switch on control box in fold position.
3. Operate the proper hydraulic tractor control and press and hold the AXLE switch up to lower transport axle to field turnaround position.
4. Operate the proper hydraulic tractor control and press and hold the HITCH button down to lower drawbar.

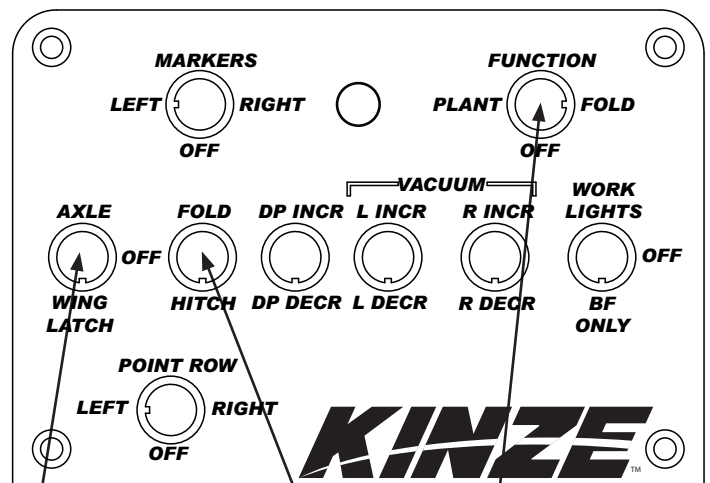

3

Control Box



Wing Wheels in Field Turnaround Position

- Operate the proper hydraulic tractor control and press and hold the WING LATCH switch down to unlatch wings.

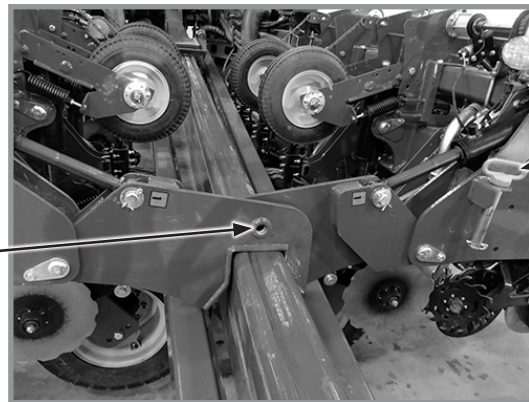
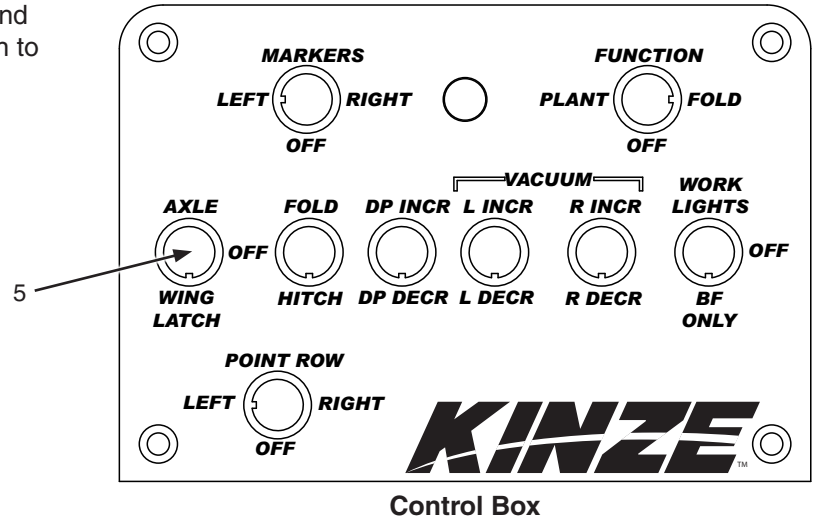

Hitch Release from Wing Latch

NOTICE Bulk fill/dry fertilizer hoses have to be inspected daily. Confirm that hoses are not pinched between stub wing and vacuum manifold.

NOTICE Unfolding planter without using tractor to assist may cause equipment damage especially in soft conditions or when loaded with seed or fertilizer. Use tractor to reduce stress on frame, drive, and transport components.

- Operate the proper hydraulic tractor control and press the FOLD switch up to move wings out, away from tractor. Planter is completely unfolded when stub wings are latched into the H-frame as shown in bottom photos.

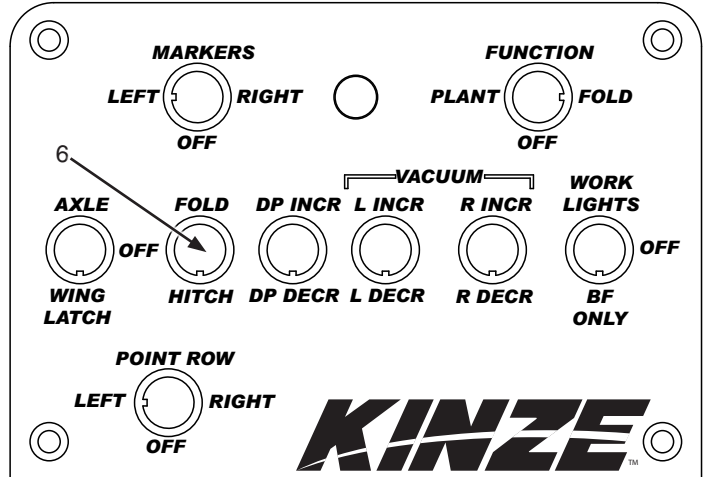

Control Box

- Move drawbar hitch to level machine during planting.
- Lower planter and hold hydraulic lever until toolbar is level.



Stub Wing Latched into Frame

FIELD TO TRANSPORT SEQUENCE USING KINZE BLUE VANTAGE® SYSTEM

NOTE: Refer to the Blue Vantage® (M0288) manual for more information.

FIELD TO TRANSPORT SEQUENCE USING CONTROL BOX (AGLEADER)

Position planter in a relatively flat open area without furrows, etc.

NOTICE	It is critically important to follow the fold and unfold sequence to avoid possible significant damage to the planter.
---------------	---

SUMMARIZED FIELD TO TRANSPORT SEQUENCE USING CONTROL BOX	
NOTICE	Tractor must be in neutral and allowed to roll freely when folding to prevent equipment damage, especially in soft conditions. Use tractor assist as needed to aid in unfolding and to reduce stress on frame and transport components.
<ol style="list-style-type: none"> 1. Place function switch on control box in FOLD position. 2. Place planter into field turnaround position. 3. Fold wings in toward tractor. 4. Engage wing latches around the hitch tube to lock the wings. 5. Raise hitch to transport height. 6. Raise transport axle to transport height. 7. Install lockups. 	
NOTE: Read following information for detailed instructions.	

NOTICE	DO NOT fold or unfold planter without planter attached to a tractor. DO NOT unhitch planter from tractor unless fully folded for transport or fully unfolded with planting units lowered to ground.
---------------	--

1. If equipped with row markers, remove lockups from storage and install on marker cylinder rods.



Row Marker Safety Lockup Installed

- Operate proper hydraulic tractor control to raise planter into field turnaround position.



- Place FUNCTION switch on control box in fold position.
- Operate proper hydraulic tractor control and press the HITCH switch down to lower drawbar all the way down.

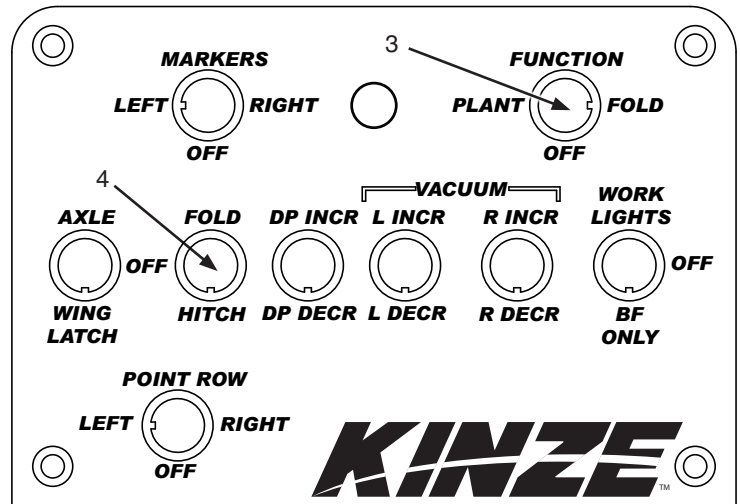

Control Box

NOTICE

Unfolding planter without using tractor to assist may cause equipment damage especially in soft conditions or when loaded with seed or fertilizer. Use tractor to reduce stress on frame, drive, and transport components.

- Operate the proper hydraulic tractor control and press the FOLD switch up until wings are parallel with hitch tube.
- Lower the wing latches around the hitch tube to lock the wings.

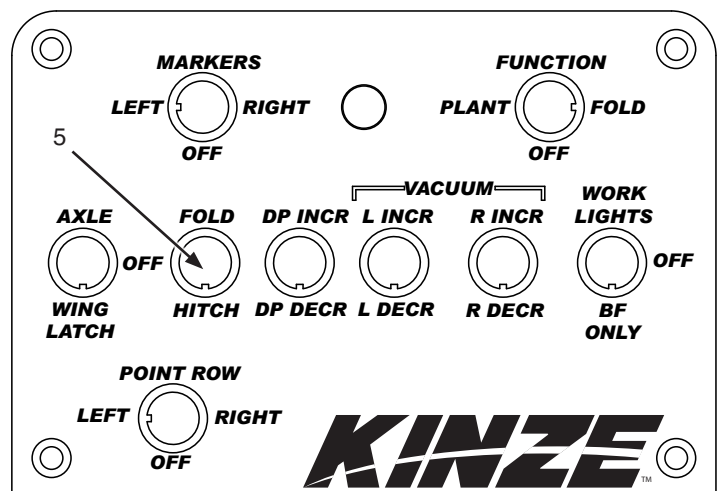

Control Box



Planter Folding



Wing Latch Pin
(Lock Position)

Wing Latch Pin
(Storage Position)

Wing Latch Engaged

7. Raise the hitch to transport height.
8. Raise transport axle.
9. Install locking pin on drawbar.
10. Install lockups.

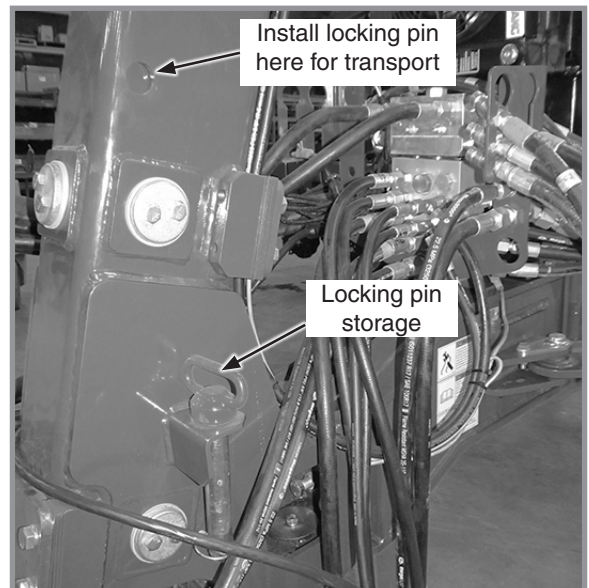

Locking Pin for Drawbar Hitch

ROW MARKER OPERATION USING KINZE BLUE VANTAGE® SYSTEM

NOTE: Refer to the Blue Vantage® (M0288) manual for more information.

ROW MARKER OPERATION USING CONTROL BOX (AGLEADER)

DANGER

Contacting or coming close to power lines or other high energy sources will cause death or serious injury.

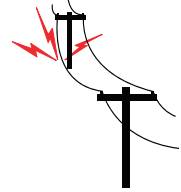

Keep away from power lines or high energy sources at all times.

NOTICE

When marker option is installed, a CAT 5 hitch must be used. A CAT 4 hitch will be overloaded.

1. Place FUNCTION switch in PLANT position.
2. Place MARKERS switch in LEFT or RIGHT position.
3. Toggle switch to other side to operate opposite row marker.
4. Raise row marker at end of field.
5. After turn, lower the pre-selected row marker.
6. Continue to follow this procedure.

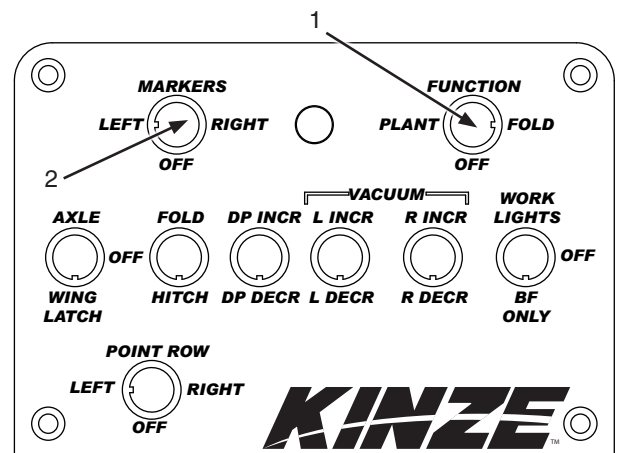

Control Box

Two solenoid valves on valve block at rear L.H. side of center frame, and a three position selector switch on control console permit operator to lower or raise desired row marker.

NOTE: See [“Row Marker Speed Adjustment”](#) on page 2-34 .

NOTE: Both row markers can be lowered by operating switch in each position and hydraulic control twice. Row markers raise simultaneously with hydraulic control in raise position.

If electrical system does not operate properly:

- Check fuse.
- Check wiring connections.
- Check control switch.
- Check solenoid. SOLENOID HOUSING IS MAGNETIZED WHEN ENERGIZED.



Row Marker Solenoid Valves

ROW MARKER SPEED ADJUSTMENT

NOTICE

Excessive row marker travel speed can damage row markers. Adjust flow controls before row markers are first used.

Marker hydraulic system includes two flow control valves. One flow control valve sets lowering speed and one sets raising speed of both markers. Flow controls determine amount of oil flow restriction through valves, varying marker travel speed.

Loosen jam nut and turn control clockwise, or IN to slow travel speed. Turn counterclockwise, or OUT to increase travel speed. Tighten jam nut after adjustments are complete.

NOTE: Tractors with flow control valves. Make row marker speed adjustment with tractor flow controls in maximum position. After row marker speed is set, adjust tractor flow controls to allow hydraulic control to stay in detent during marker raise or lower cycle.

NOTE: Hydraulics operate slowly when oil is cold. Make all adjustments with oil warm.

NOTE: On a tractor where oil flow cannot be controlled, tractor flow rate may be greater than rate marker cylinder can accept. Hold tractor hydraulic control lever until cylinder reaches end of its stroke. This occurs most often on tractors with an open center hydraulic system.

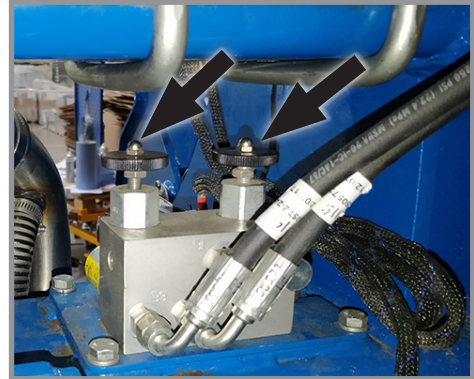

Row Marker Speed Control Adjustment

This page intentionally left blank.

ROW MARKER CABLE ADJUSTMENT

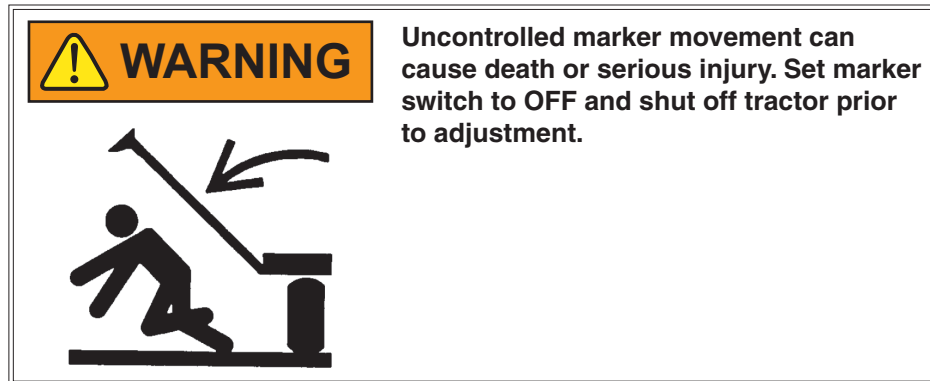

NOTE: Operate two-fold or three-fold row markers with the tractor's hydraulic valve in float position.

NOTE: A cable or chain may be used. For continuity, cable will be used in this manual.

Cable adjustment is critical. Adjust with second stage of marker in vertical position and first stage in horizontal position.

Cable must be adjusted so third stage of marker is pulled out as soon as second stage begins outward travel. Cable stretches with use and needs routine adjustment. It may be necessary to twist for a finer adjustment.

Marker cable is PROPERLY ADJUSTED if marker blade pushes dirt 12 (~31 cm) or less as marker completes fold into field operating position. Cable should have some slack when marker is in field operating position.

Marker cable is TOO LOOSE and should be adjusted if marker blade pushes dirt more than 12" (~31 cm) as it completes the fold into field operating position.

Marker cable is TOO TIGHT if it will not allow marker blade to follow ground contour and cable is tight when marker is in field operating position.

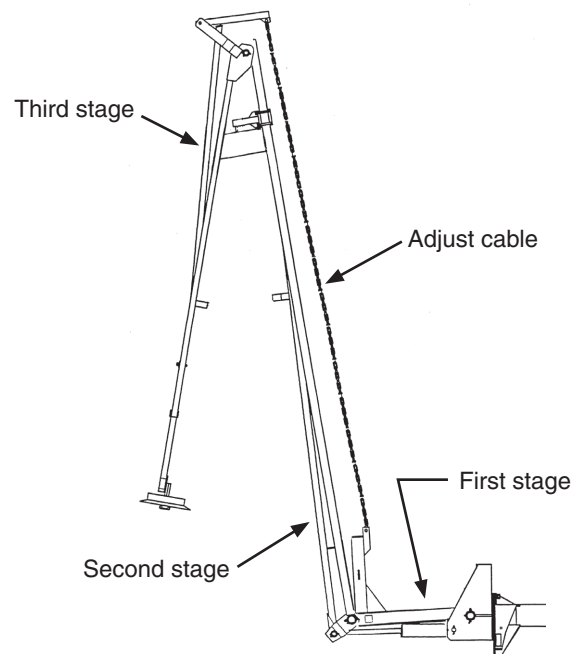

ROW MARKER LENGTH AND DISC BLADE ADJUSTMENT

1. Multiply number of rows by the average row spacing to determine total planting width.

Row Marker Lengths	
24 Row 70 cm	16,80 m

2. Lower planter and row marker assembly to ground.
3. Measure from planter center line to a point where blade contacts ground.
4. Adjust row marker extension so distance from marker disc blade to center line of planter is equal to total planting width. Adjust right and left row marker assemblies equally and securely tighten clamping bolts.

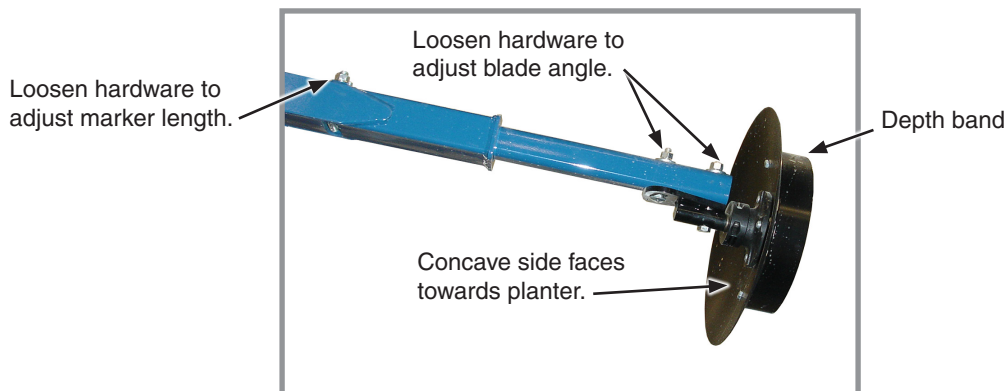

Row Marker Disc Blade Angle Adjustment

NOTICE

Setting marker disc blade assembly at a sharper angle than needed adds stress to row marker assembly and shortens bearing and blade life. Set blade angle only as needed to leave a clear mark.

Marker disc blade is installed with concave side facing inward. Spindle assembly is slotted so hub and blade can be angled to throw more or less dirt.

5. Loosen hardware and move assembly as required.
6. Tighten bolts to specified torque (see ["Mounting Bolts and Hardware" on page 6-7](#)).
7. Do a field test to ensure markers are properly adjusted (see ["Field Test" on page 2-46](#)).

NOTE: A notched marker blade is available from Kinze through your Kinze Dealer for use in more severe no till conditions.

VACUUM METER SYSTEM

Kinze vacuum meter seed metering system includes seed meters, seed discs, and an air system consisting of a hydraulic driven vacuum fan which draws air through manifolds, hoses, and seed meters on each row unit.

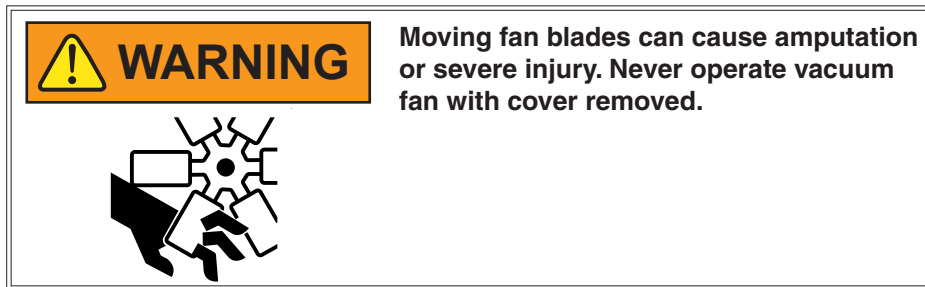

ANALOG VACUUM OR PRESSURE GAUGE

Analog vacuum or pressure gauge connects directly to vacuum manifold (vacuum) or bulk fill (pressure) manifold and is teed into digital sending units.

Only adjustment is to "zero" needle with no vacuum or pressure present. If there is a significant difference between gauge and a reading taken at meters, a different manifold location should be found to connect hose to gauge and digital sending unit.

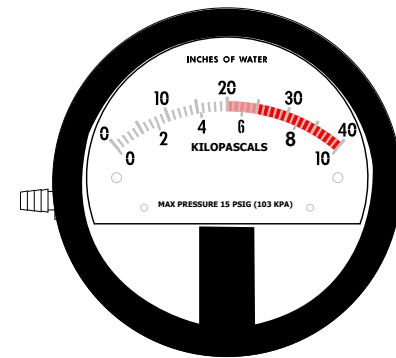

Analog Gauge

NOTE: Analog gauges are identical EXCEPT for plug and hose barb locations in side of gauge housing. DO NOT connect vacuum meter or bulk fill hose to wrong gauge. Check plug and hose barb installation if readout is erratic or appears inaccurate.

BULK FILL SYSTEM**WARNING**

Do not remove lid during machine operation. Contents are pressurized and could result in death, serious injuries or equipment damage.

Review operator manual for proper filling procedure.

**CAUTION**

Seed flying out of disconnected delivery tube at high velocity can cause injury. Do not disconnect delivery tubes when system is operating.

**DANGER**

DO NOT ENTER. Hazardous conditions inside will result in death or serious injury. Follow OSHA confined space procedures.

NOTICE

Foreign materials can plug system. Make sure seed is clean and free of debris when filling bulk fill hoppers.

NOTICE

Do not turn on system with tractor engine at full speed or system damage may occur.

NOTICE

Do not operate bulk fill system above maximum system operating pressure of 20 inches (~51 cm) of water or seed bridging may occur.

1. **Before filling hoppers, refer to “Additives” on page 3-9 for more information.** Fill hoppers with seed, then twist lid clockwise to close.
2. Start bulk fill delivery system with tractor engine at idle.
3. Increase engine speed to full and set initial system pressure using flow control valve.
4. Allow system to warm up and adjust pressure if necessary.

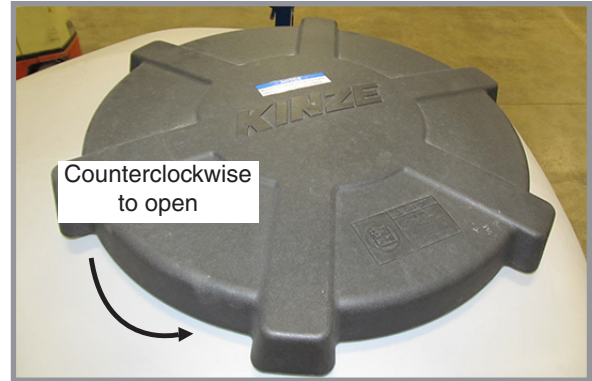

Bulk Fill Lid

Recommended pressures:

For optimal pressures for each type of culture and seed, see “[Vacuum Settings](#)” on page 3-5.

BULK FILL ENTRAINER ACCESS

1. Shut down bulk fill system.
2. Loosen wing nut and turn retainer holding shutoff door in its storage location.
3. Remove rubber plug closest to area in entrainer needing attention.
4. Insert shutoff door into open slot and push into entrainer at a slight upward angle.
5. When work is complete, remove shutoff door, return door to storage location, and plug open slot.

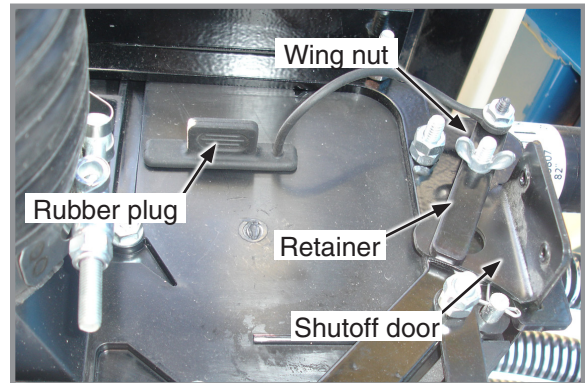

Bulk Fill Entrainer (End View)

BULK FILL TANKS - CLEAN OUT



Cleanout Chute Storage Location

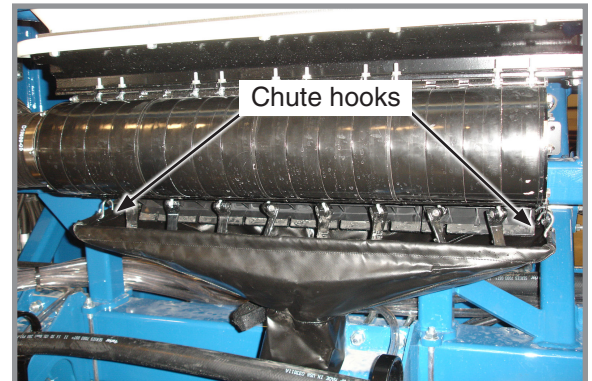

Cleanout Chute Installed

1. Remove bulk fill tank cleanout chute from storage location under L.H. bulk fill tank.
2. Position tube of chute under entrainer and attach hooks on each end of entrainment assembly.
3. Open cleanout doors and empty tank.
4. Close all cleanout doors and return cleanout chute to storage location.

BULK FILL SCALE PACKAGE OPTION

NOTICE

High-pressure water can damage display. Remove display before power washing planter.

NOTICE

Remove and store display at end of planting season. Damage from sun and weather exposure may result.

Bulk Fill Scale Package is capable of:

- Displaying seed weights and estimated acres remaining for bulk fill hoppers separately.
- Setting alarm to warn operator when seed goes below a pre-defined level.

NOTE: Operation of Bulk Fill Scale Package display is controlled by touchscreen.

NOTE: Screen position is changed by loosening the thumb screw on RAM™ mount.

STORAGE

At end of planting season, remove display. Otherwise damage from sun and weather exposure may result.

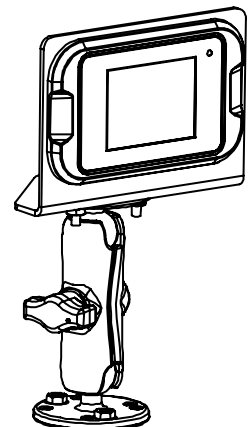

To monitor seed levels (Main Screen):

NOTE: Only applicable to Ag Leader InCommand, refer to Blue Vantage manual for bulk fill scale user information.

1. Main screen displays information for left and right hoppers.
2. Tap "Weight" to display left and right hopper weight.
3. Tap "Area to Empty" to display left and right acres to empty.

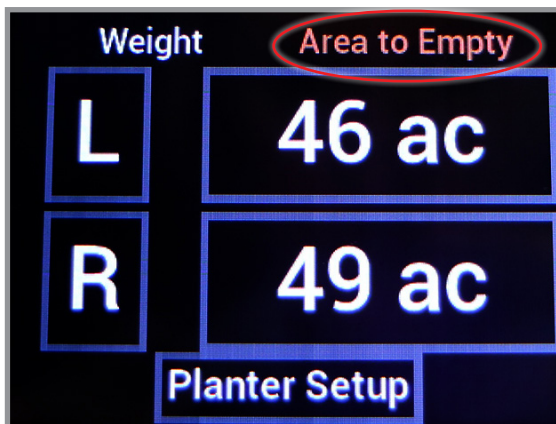

4. Tap either "L" or "R" to display detailed hopper screen.

NOTE: "Zero" is selected to zero hopper that is selected. If hopper(s) is zeroed out with seed, weight in hopper will not be recognized. To reset hopper correctly seed must be emptied from hopper(s) and then zeroed to reset.



5. Tap "Back" to return to main screen.
6. Tap "Planter Setup" to enter Seed information. See follow page for more information.

To enter seed information (Not applicable on Blue Vantage):

NOTE: Seed information entered must be accurate for remaining estimated acres to calculate correctly.

- SEEDS/ACRE is population rate.
- SEEDS/LB value comes from seed specifications.

1. From main screen, tap "Planter Setup".
2. From planter setup screen, tap "Seed Setup".

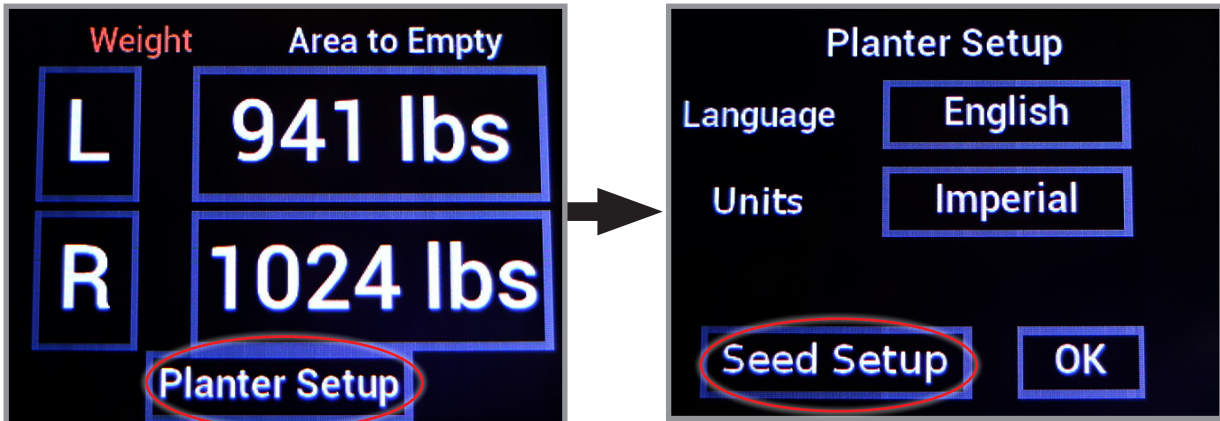

3. To change values in either "Seeds/Ac", "Seeds/lb", or "Alarm Level" tap in appropriate box.
4. At input screen, enter desired value. Tap "OK".

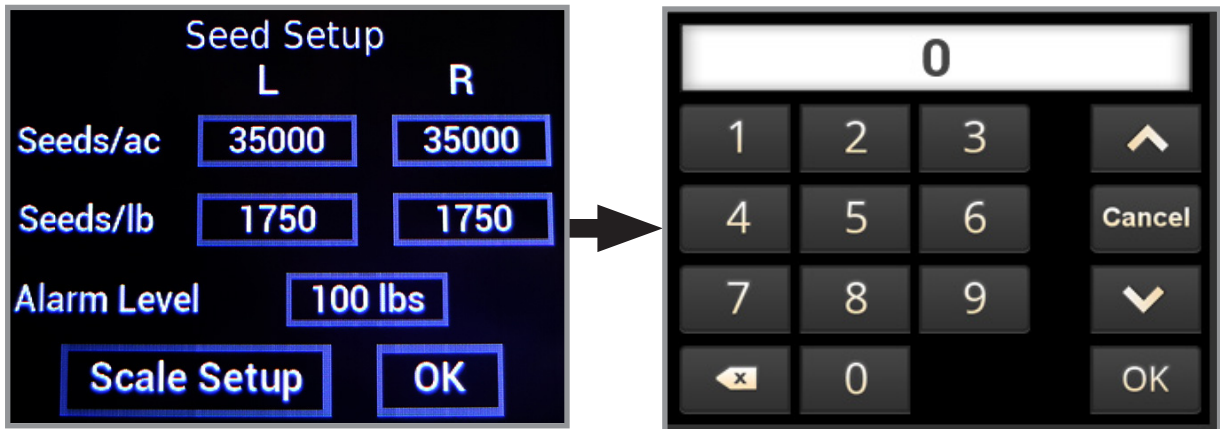

5. Once desired values have been entered tap "OK", to confirm changes tap "Accept" to return to main screen.

NOTE: It is NOT RECOMMENDED to make adjustments to setup in the "Scale Setup" screen.

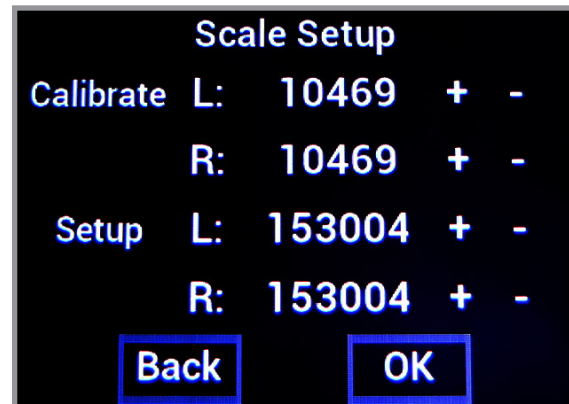

Software Version:

1. From main screen, tap "Planter Setup".
2. Tap on "English" to display software version.

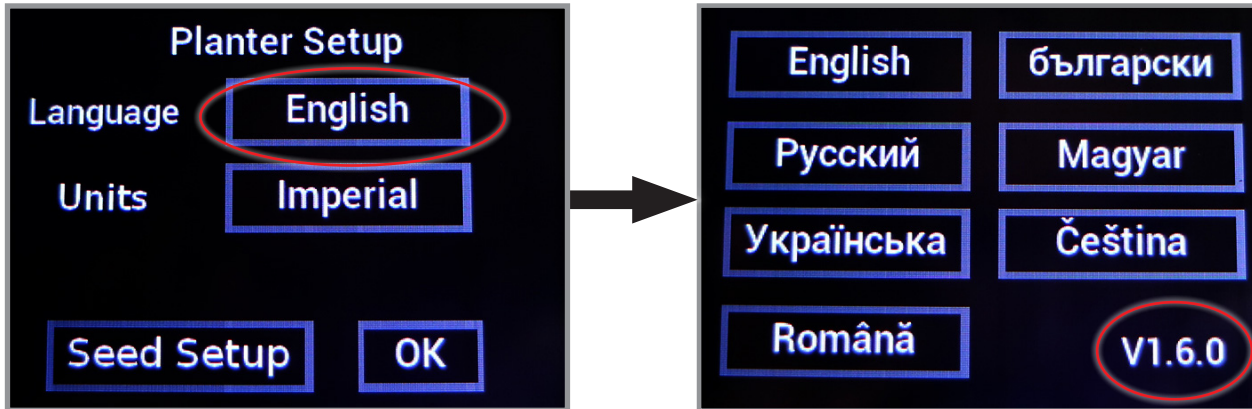

4. Tap "English" to return to planter setup screen.
3. Tap "OK" to return to main screen.

Language/Units:

NOTE: English is the default language. Imperial is the default units.

1. From main screen, tap "Planter Setup".
2. Tap on "English" to display language options.

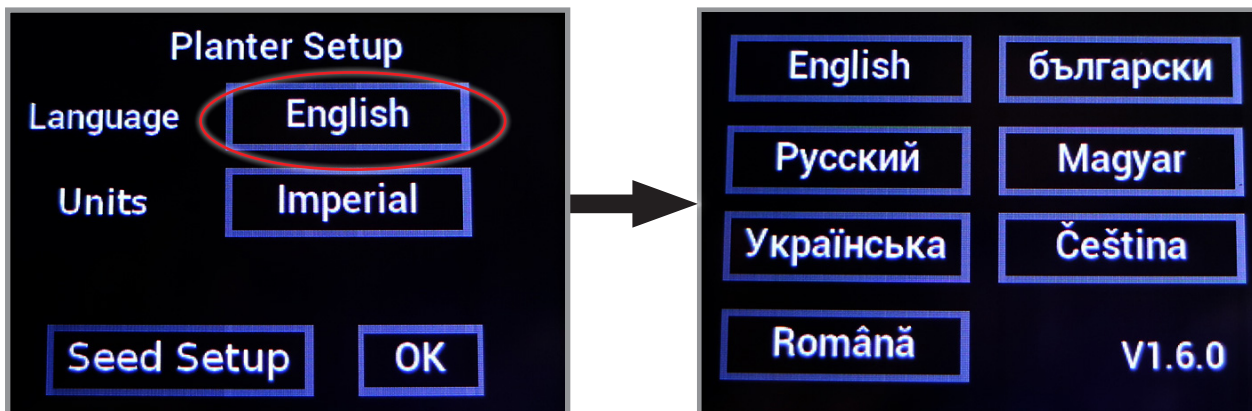

3. Tap on desired language to select and return to planter setup screen.
4. Tap on "Imperial" to switch to metric units and vice versa.

NOTE: If units are switched back and forth between imperial and metric, measurements will round up each time.

3. Tap "OK" to return to main screen.

POINT ROW CLUTCHES

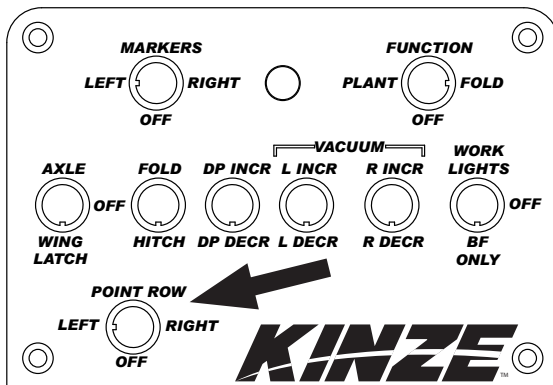

Control box

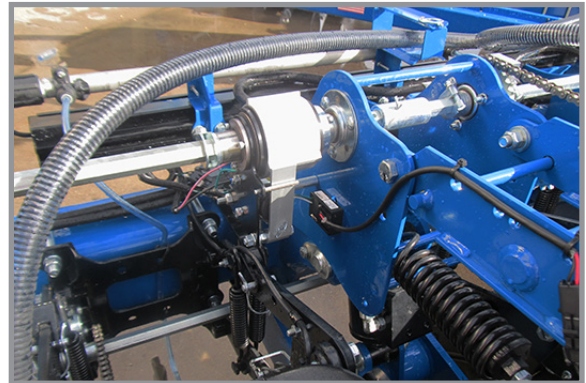

Point row clutch

Electric-activated clutches disengage drive on either half of planter for finishing up fields or for long point row situations. Clutch selector switch is located on tractor control box.

NOTE: Liquid fertilizer piston pump has its own drive wheel and is not affected by point row clutch.

NOTICE

Switch must be OFF when planter is not in use or tractor battery will be drained.

Clutch consists of a wrap spring riding on an input and output hub. Wrap spring is wrapped tightly over hubs during operation locking them together. Higher speeds create a tighter grip of spring on hubs.

Input end of spring is bent outward and is called the control tang. Control tang fits into a slot in stop collar located between input and output hubs over wrap spring. If stop collar is allowed to rotate with input hub, clutch is engaged. If stop collar is stopped from rotating, control tang connected to it is forced back and spring opens. This allows input hub to continue rotating without transmitting torque to output hub, stopping planter drive.

Stop collar is controlled by an electric solenoid and an actuator arm. When selector switch on tractor control box is OFF, solenoid coil is NOT ENERGIZED and actuator arm will not contact stop on stop collar, allowing it to rotate with hubs and drive planter.

When operational switch is in "DISENGAGE" (right or left) solenoid coil IS ENERGIZED and plunger in solenoid coil pulls actuator arm against stop on stop collar, disengaging wrap spring and stopping planter drive.

FIELD TEST

Perform a field test with any change of field and/or planting conditions, seed size or planter adjustment to ensure proper seed placement and operation of row units.

- Check planter for front to rear and lateral level operation. See [“Level Planter” on page 2-24.](#)
- Check **all** row units to be certain they are running level. Row unit parallel arms should be approximately parallel to the ground when planting.
- Check row markers for proper operation and adjustment. See [“Row Marker Speed Adjustment” on page 2-34,](#) [“Row Marker Cable Adjustment” on page 2-36,](#) and [“Row Marker Length And Disc Blade Adjustment” on page 2-37.](#)
- Check for desired depth placement and seed population on **all** rows. See [“Field Check Seed Population” on page 2-46.](#)
- Check for proper application rates of fertilizer on **all** rows. See [“General Planting Rate Information” on page 5-1.](#)

Reinspect machine after field testing.

- Hoses And Fittings
- Bolts And Nuts
- Cotter Pins And Spring Pins
- Drive Chain Alignment
- Confirm Bulk Fill and dry fertilizer hoses were not crushed during fold/unfold operation.

FIELD TEST USING BLUE VANTAGE SYSTEM

Refer to the Blue Vantage (M0288) manual for more information.

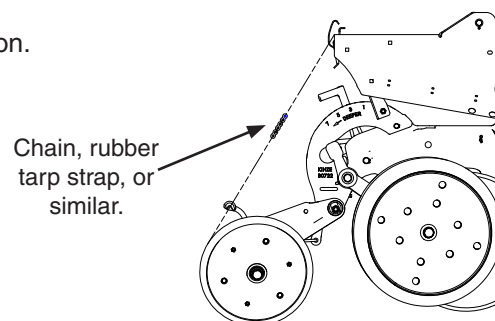

FIELD CHECK SEED POPULATION

1. Tie up one or more sets of closing wheels by running a chain or rubber tarp strap between the hopper support panel and closing wheels. It may be necessary to decrease closing wheel arm spring tension.
2. Plant a short distance and check to see if seed is visible in the seed trench. Adjust planting depth to a shallower setting if seed is not visible and recheck.

Planting depth adjustment handle

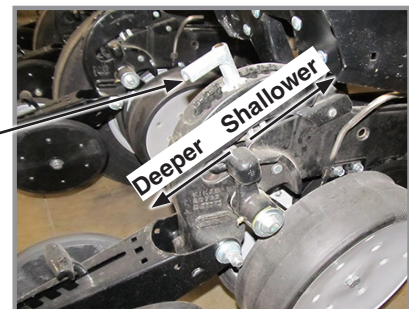

Planting Depth Adjustment

3. Measure 1/1000 of a hectare. See chart for correct distance for row width being planted. For example, if planting 70 cm rows 1/1000 of a hectare would be 14,28 m.

1/1000 Hectare Seed Population Count Row Width/ Distance	
Row Width	70 cm
Distance	14,28 m

NOTE: Seeds may bounce or roll when planting with closing wheels raised and planting depth set shallow affecting seed spacing accuracy.

4. Count seeds in measured distance.
5. Multiply number of seeds placed in 1/1000 of an hectare by 1000. This gives total population.

EXAMPLE: 70 cm row spacing 14,28 m equals 1/1000 hectare.

75 seeds counted x 1000 = 75000 seeds per hectare

Seed count can be affected by drive wheel and seed meter drive ratio, tire pressure, and/or seed meter malfunction.

1. If seed check shows average distance between seeds in centimeters is significantly different than seed rate chart indicates, first check drive ratio between drive wheel and seed meter. Check drive wheel air pressure, check for incorrect sprocket(s) in driveline and check drive and driven sprockets on transmission(s) for proper selection.
2. Check for seed meter malfunction. For example, if spacing between kernels of corn at the transmission setting being used is 20 cm and a gap of 40 cm is observed, a finger has lost its seed and not functioned properly. If two seeds are found within a short distance of each other, the finger has metered two seeds instead of one.
3. See [“Vacuum Seed Meter” on page 7-4](#) of this manual.

DETERMINING KILOGRAMS PER HECTARE

Seeds per hectare ÷ Seeds per kg (from label) = Kilograms per hectare

If seeds per kilogram information is not available use the following averages:

5700 seeds per kilogram for medium size soybeans

33000 seeds per kilogram for medium size milo/grain sorghum

9900 seeds per kilogram for medium size cotton

DETERMINING LITERS PER HECTARE

Kilograms per hectare ÷ Seed unit weight = Liters per hectare

Average Unit Weight of:



1 Liter Soybeans = 0,773 kg/l

1 Liter Milo/Grain Sorghum = 0,722 kg/l

1 Liter Cotton = 0,412 kg/l

FIELD CHECK GRANULAR CHEMICAL APPLICATION

Temperature, humidity, speed, ground conditions, flowability of different material, or meter obstructions can affect granular chemical rate of delivery.

 WARNING	<p>Agricultural chemicals can cause death or serious injury to persons, animals, and plants or seriously damage soil, equipment, or property. Read and follow all chemical and equipment manufacturers labels and instructions.</p>
	

Perform a field check to determine application rates.

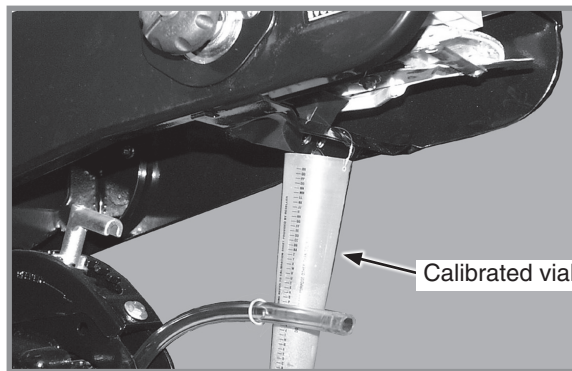

Granular chemical field check

1. Fill insecticide and/or herbicide hoppers.
2. Attach a calibrated vial to each granular chemical meter.

NOTE: Disengage clutch to avoid dropping seed during test.

3. Lower planter and drive 400 meters at planting speed.
4. Weigh chemical in grams caught in one vial.
5. Multiply that amount by factor shown to determine kilograms per hectare.

Kilograms Per Hectare	
Row Width	Factor
70 cm	0,0357

EXAMPLE: You are planting 70 cm rows. You have planted for 400 meters at desired planting speed. You caught 337 grams of chemical in one vial. 337 grams times 0,0357 equals 12 kilograms per hectare.

NOTE: Check calibration of all rows.

METERING GATE

Use metering gate setting as a starting point for distributing insecticide or herbicide. Charts are based on 8 km/h planting speed. Use a higher gate setting for speeds faster than 8 km/h and a lower setting for speeds slower than 8 km/h.

WATER TANK

The water tank is to only be filled with clean water or preferably potable water (water meeting local standards for drinking). The tank holds 4 gallons (~15 l) of water. Be sure to check for regulations pertaining to this use. Tank should be filled with new water at the beginning of each planting season and drained at the end of each planting season.

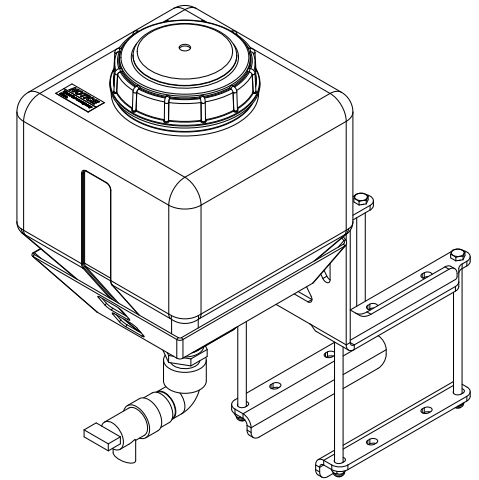

NOTICE

Drain tank if environmental conditions are 0° Celsius or below to prevent tank from cracking.

The water tank is to be used in the event of an accidental exposure to chemical. Chemicals are supplied with Material Safety Data Sheets (MSDS) that provide full information about the chemical, its effects on exposure, and first aid needs in the event of an emergency. Keep your MSDS file up-to-date and available for first responders in case of emergency.

If the water tank is used seek medical assistance immediately for further treatment.

This page intentionally left blank.

PLANTING DEPTH

Planting depth is maintained by adjustable row unit gauge wheels. Depth adjustment range is approximately $\frac{1}{2}$ " to $3\frac{1}{2}$ " (~1 cm to 9 cm).

1. Raise planter to remove weight from wheels.
2. Push down on depth adjustment handle and reposition it forward to decrease or rearward to increase planting depth. Initially adjust all units to the same setting.
3. Lower planter and check operation and planting depth of all row units. Readjust individual rows as needed for uniform operation.

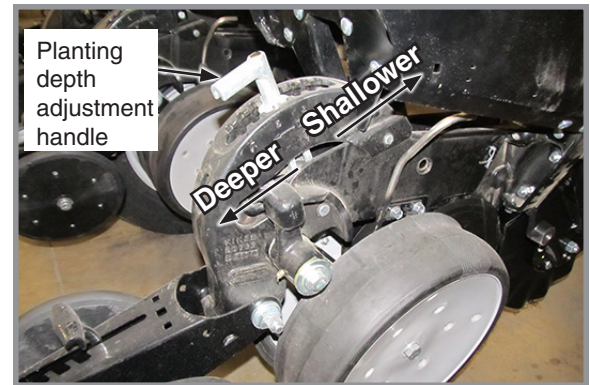

Planting Depth Adjustment

“V” CLOSING WHEEL ADJUSTMENT (RUBBER OR CAST IRON)

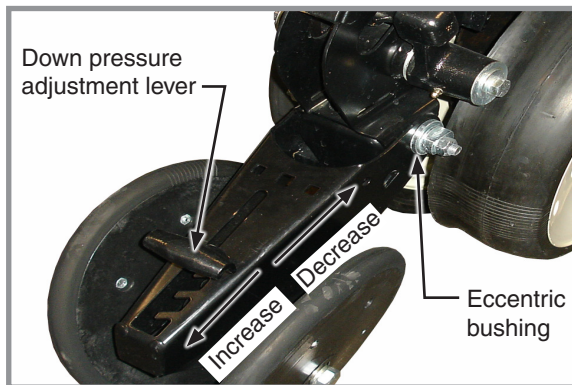

“V” Closing Wheel Adjustments

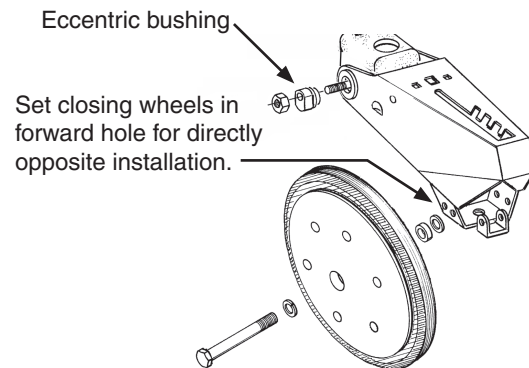

“V” closing wheels should have enough down pressure to close the seed trench and ensure good soil to seed contact. Move 5-position quick adjustable down force lever on the top of closing wheel arm to the rear to increase closing wheel spring pressure. Move lever forward to decrease pressure. Adjust all row units to a similar setting. Light soil usually requires less down force at average depth (approximately 5 cm) while heavy soil requires increased down force.

Eccentric bushings in the wheel arm stop allow for lateral adjustment of the “V” closing wheel assembly. Use a $\frac{3}{4}$ " wrench to loosen hardware attaching closing wheel arm to wheel arm stop. Use another $\frac{3}{4}$ " wrench to turn eccentric bushings until **closing wheels are aligned with seed trench**. Tighten hardware.

Closing wheels can be installed “offset” (to improve residue flow) or “directly” opposite. Use forward installation holes if set “directly” opposite.

CLOSING WHEEL SHIELD (RUBBER OR CAST IRON “V” CLOSING WHEELS)

Optional closing wheel shield is installed on underside of closing wheel arm to help prevent root balls and stalks from clogging closing wheels.

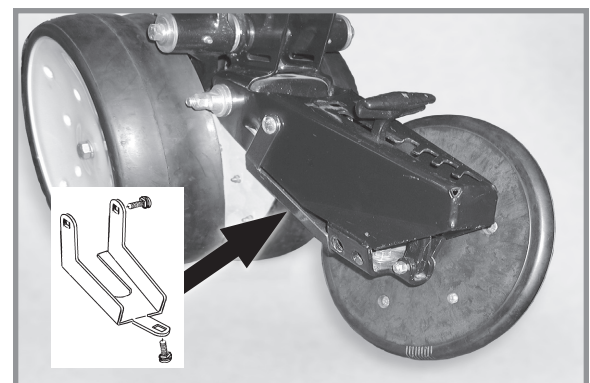

Closing Wheel Shield (closing wheel removed)

QUICK ADJUSTABLE DOWN FORCE SPRINGS OPTION

Quick adjustable down force springs increase penetration in hard soil and keep row unit from bouncing in rough field conditions. Two springs per row, one on each side parallel arms, are used unless equipped with row unit mounted no till coulters. Four springs per row are used with row unit mounted no till coulters.

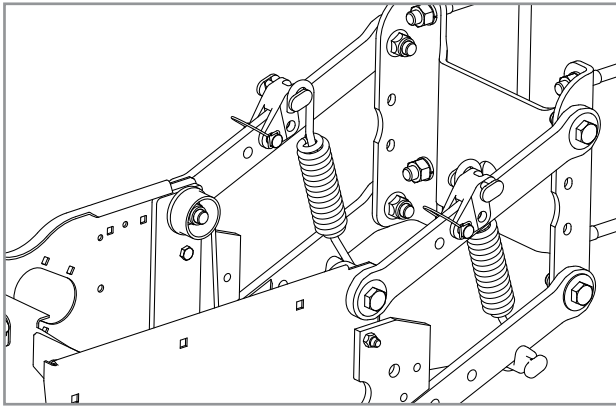

Two Springs Per Row (Dual)

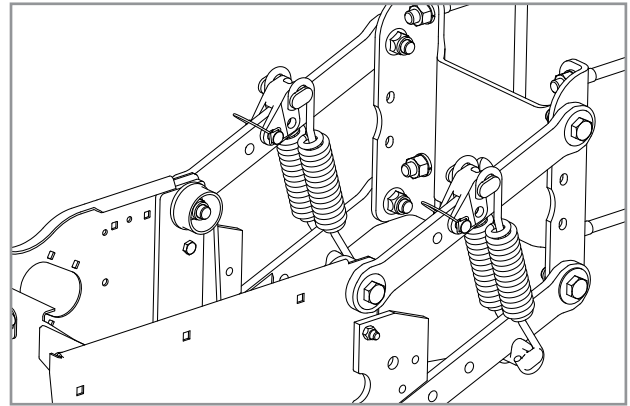

**Four Springs Per Row (Quad)
(Row Unit Mounted No Till Coulters Only)**

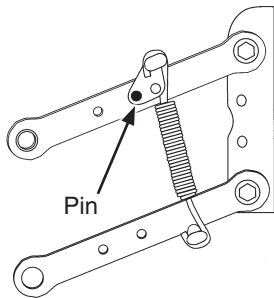

Position 1 (Least)

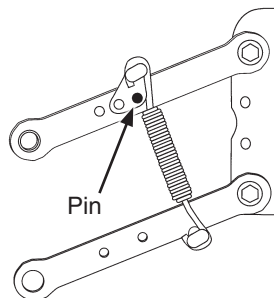

Position 2

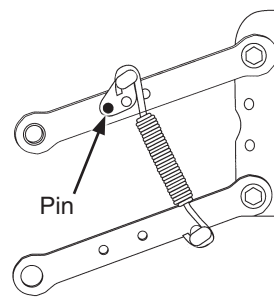

Position 3

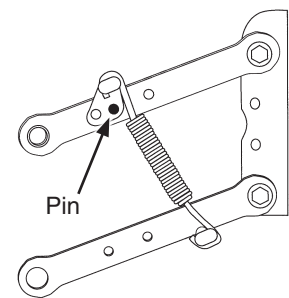

Position 4 (Most)

There are four positions to set down pressure spring tension.

NOTICE

Springs must be installed with open side of spring hooks toward seed hoppers to prevent binding on spring mount adjustment pins.

1. Raise planter and remove spring mount pin at top of spring.
2. Slide mount to desired position and install pin.

NOTE: Adjust springs for field conditions. Too much down pressure in hard field conditions can cause row units to lift planter and keep drive wheels from making contact. Too much down pressure in soft field conditions can cause row unit to run too deep.

Heavy Duty Spring Down Force Pressure*		
	2 Springs	4 Springs
Position	Heavy Duty P/N: D21337	Heavy Duty P/N: D21337
1	43 lb (19.5 kg)	80 lb (36.3 kg)
2	86 lb (39.0 kg)	144 lb (65.3 kg)
3	167 lb (75.7 kg)	307 lb (139.3 kg)
4	249 lb (113.0 kg)	470 lb (213.2 kg)

*Pressure does not include weight of row unit, seed, or options.

PNEUMATIC DOWN PRESSURE (PDP)

Row unit down pressure can be adjusted on-the-go as field conditions change. ISOBUS monitor adjusts pressure. One planter-mounted 12 VDC air compressor with 11 l capacity air tank supplies air for the down pressure system. PDP provides a maximum down pressure of approximately 218 kg/row.

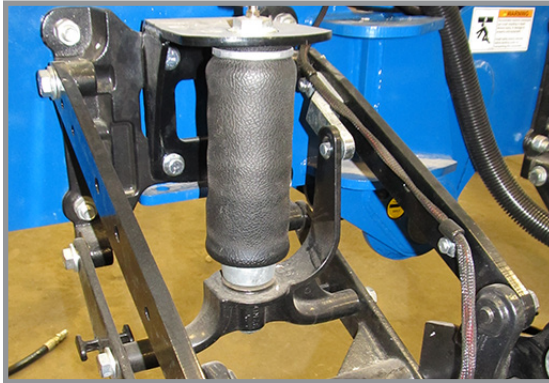

Row Unit Air Spring



Real-time downforce calculation

$$\text{PSI} \times 4 \times 0.45 = \downarrow \text{kg}$$

$$\text{MAX.} \sim 218 \text{ kg}$$

Packages include upper and lower air spring mounting castings for pull row units, 150 PSI (~1034 kPa) rated air springs, 3/8" O.D. nylon hoses, dual solenoid air valve and stainless steel, 160 PSI (~1103 kPa), 2" liquid-filled gauge and planter wiring harness.

NOTE: Assist springs are available through your Kinze dealer if additional down pressure is needed.

FIELD OPERATION

NOTE: Adjust down pressure with planter lowered and row openers in ground for most accurate adjustment.



Air Compressor

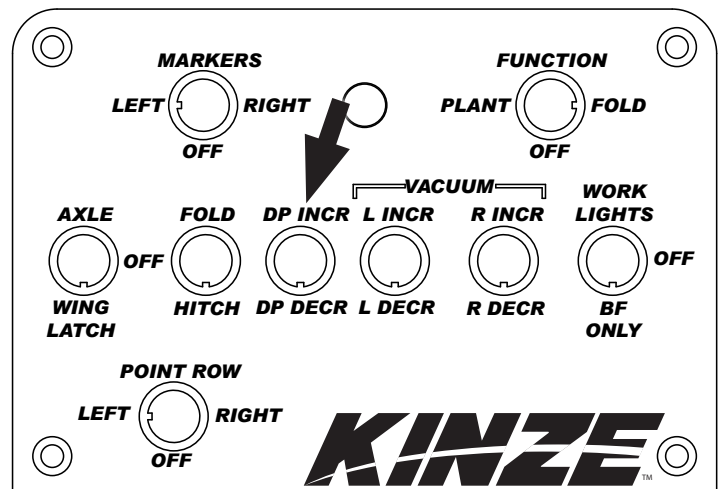

Control Box









ADJUST DOWN PRESSURE FROM CAB

For models equipped with a control box, toggle the Down Pressure Switch up or down to increase or decrease down force.

For models equipped with Kinze Blue Vantage system refer to Blue Vantage Manual (M0288).

This page intentionally blank.

VACUUM SETTINGS

Crop		**Seed Disc Kit	Seed Disc Part No.	Ejector Wheel (Color)	Cells	Seed Size Range	Singulator Zone Setting	Vacuum Setting Inches of Water (cm)	Lubricant
	Corn ‡ Large Sweet Corn	G11043X	B1219 (Light Blue)	1 row 5 punches (Light Blue)	40	2500-5000 seeds/kg	2	18-20 (46-51)	Graphite* Talc*
	Soybean	G11047X	B1232 (Black)	2 rows 6 punches (Black)	120	4850-8820 seeds/kg	0	10-14 (25-36)	Graphite* Talc*
	Sugar Beet	G11045X	B1229 (Dark Orange)	1 row 6 punches (Dark Orange)	60	Pelletized	2	15 (38)	Graphite*
	Milo	G11045X	B1229 (Dark Orange)	1 row 6 punches (Dark Orange)	60	22000-44000 seeds/kg	2	15 (38)	Graphite* Talc*
	Sunflower ‡ Small Sweet Corn	G11044X	B1230 (Gray)	1 row 5 punches (Gray)	40	Oil seeds #2, 3, 4	2	12-18 (30-46)	Graphite* Talc*
	Sunflower	G11044X	B1230 (Gray)	1 row 5 punches (Gray)	40	Oil seeds #5	2	5-8 (13-20)	Graphite* Talc*
	Specialty Disc 1	G11039X	B1233 (Green)	1 row 6 punches (Green)	60	Cotton	2	15-20 (38-51)	Graphite* Talc as needed*
	Specialty Disc 2	G11040X	B1235 (Brown)	1 row 6 punches (Green)	60	Black turtle & navy edible beans	2	15-20 (38-51)	Graphite* Talc as needed*
	Specialty Disc 3	G11041X	B1234 (Dark Blue)	1 row 6 punches (Green)	60	Pinto & Great Northern edible beans & low-rate soybean	2	15-20 (38-51)	Graphite* Talc as needed*

Install selected seed disc. Position vacuum cover on meter by aligning keyhole slots over bolt heads. Push cover on meter and turn counter clockwise to lock in place.

*For More information on application rate, see [“Additives” on page 3-9.](#)

**Includes seed disc, ejector wheel, and spring.

‡Conventional hoppers only, not applicable with bulk fill.

NOTE: See [“Field Check Seed Population” on page 2-44](#) for more information. Always field check seed population to ensure planting rates are correct.

NOTE: Singulator settings are marked from 0 - 3.

NOTE: Mixing seed sizes and shapes affects meter performance. Use consistent seed size and shape.

NOTE: Use 1 tablespoon powdered graphite with each standard hopper fill of seed. Seed treatment, foreign material, dirt or seed chaff may cause gradual reduction of seed disc fill (population). See [“Additives” on page 3-9](#) for more information.

NOTE: Excessive seed treatment, humidity, and light-weight seed can affect meter performance. Use ½ cup of talc with each standard hopper fill of seed and mix thoroughly to coat all seeds and adjust rates as needed. Use of talc aids seed flow into meter, singulation, and disc seed drop.

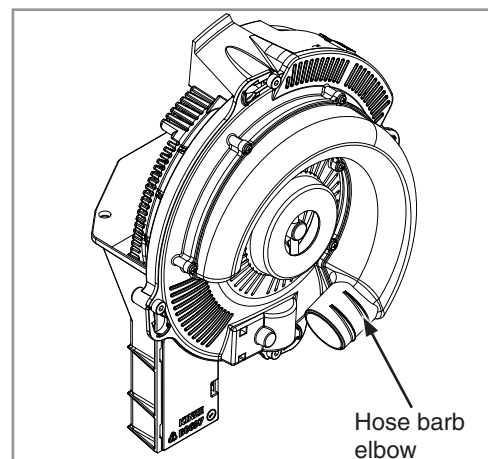
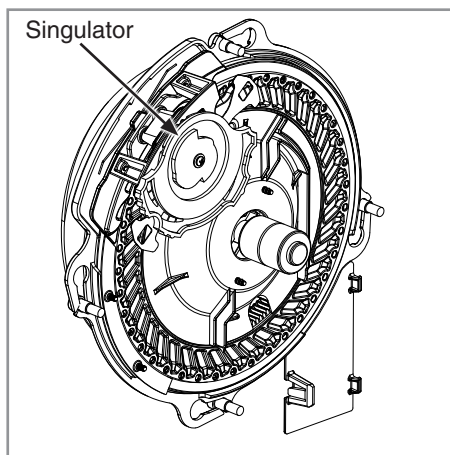

NOTE: Foreign material in seed disc orifices, such as seed chips, hulls, stems, etc., may affect seed delivery. Clean seed ensures accurate seed metering from vacuum seed meter. Remove Seed discs daily to check for buildup of foreign material in seed disc orifices.

Air inlet screens allow air to enter system and aids in keeping field residue or other foreign material out of meter.

See [“Vacuum Seed Meter” on page 7-4](#) and [“Preparation for Storage” on page 6-27](#) in Lubrication and Maintenance section for more information.

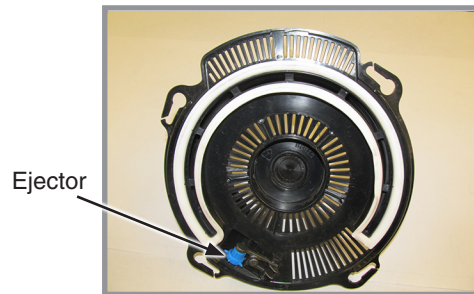

NOTE: Damaged seed or seed containing foreign material will cause plugging of seed disc orifices and require more frequent seed meter clean out to prevent underplanting.

Wheel-Type Ejectors

Wheel-type ejectors expel seed remnants from seed disc orifices. These ejectors are disc specific and colored coded to match disc.

NOTICE

Reinstall hopper lids after hoppers are filled to prevent accumulation of dust or dirt in seed meter which will cause premature wear.

NOTE: Seed size, seed shape, seed treatments, travel speed, and planting rate affect meter performance.

1. Select seed disc and ejector to match crop and population.

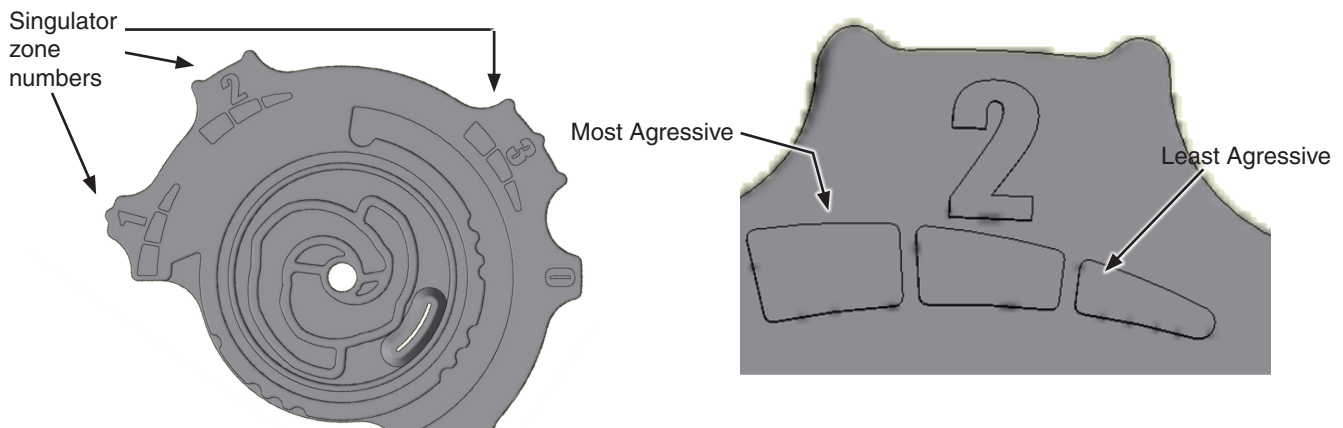

Singulator Adjustment Wheel

2. Adjust singulator wheel to initial setting. Seed size, seed shape, seed treatments, travel speed and planting rate all affect meter performance.
3. With vacuum fan running, lower planter to planting position and drive forward a short distance to load seed into seed disc cells.
4. Adjust vacuum level to initial setting according to tables on page.

NOTE: Vacuum reading will be much lower when seed disc cells are empty. Load all seed cells before setting vacuum level.

NOTE: Operate vacuum fan 3-5 minutes to bring oil up to normal operating temperature prior to making final vacuum level adjustment.

SEED METER CLEAN OUT

NOTE: Use of damaged seed or seed containing foreign material will cause plugging of seed cell orifices and require more frequent seed meter clean out to prevent underplanting.

Thorough seed meter clean out is important to maintain genetic purity.

1. Disengage seed drive and remove seed hopper and meter.
2. Dump seed from right rear corner of hopper into a container.
3. Lay hopper on its right side. Push release button and rotate seed meter vacuum cover clockwise to align keyhole slots with bolt heads. Lift off cover.
4. Rotate seed disc hub clockwise to unlock and remove seed disc.
5. Empty meter.
6. Thoroughly inspect meter to ensure all seed is removed.
7. Replace seed disc. Install vacuum cover.

ADDITIVES

GRAPHITE

The use of graphite is recommended to promote seed flow, provide lubrication for the seed meter and to help dissipate static charge buildup. Among the available dry seed lubricants graphite is the most effective and easiest to use and it requires no mechanical agitation

Row Hoppers

Mix one tablespoon of **powdered graphite** with seed each time hoppers are filled. Regular graphite use prolongs life of the seed meter components, improves seed spacing, and may reduce buildup of seed treatments.

NOTE: DO NOT apply graphite only in center of hopper. It will filter too quickly through the seed and not distribute as evenly as desired.

Apply graphite around outer perimeter of hopper.

Bulk Fill Hoppers

Mix 1 pound (~0,5 kg) bottle of powdered graphite each time the bulk seed hopper is filled. Graphite should be added in layers as the bulk seed hoppers are filled. Regular graphite use prolongs life of the seed meter components, improves seed spacing, and may reduce buildup of seed treatments.

NOTE: Additional graphite may be required to retard buildup of seed treatments on meter components. More frequent cleaning of monitor seed tubes may be necessary due to use of additional graphite.

Lubricant Application Rate	
Graphite	
Row Hoppers	1 Tbs. (~15 ml)/Hopper Fill
Bulk Fill Tan	1 Lb (~0,5 kg) Bottle/Tank
80/20 Talc-Graphite	
Row Hoppers	1/2 C (120 ml).**
Bulk Fill Tanks	8 Lbs (~4 kg)/Tank
**Must be evenly mixed during fill.	
Talc	
Row Hoppers	1/4" C. (~59 ml*)
Bulk Fill Tanks	4 Lbs (~2 kg)/Tank*
*Double amount of talc for sunflowers.	



Adding graphite to row hopper



Adding graphite Bulk Fill Hopper

80/20 TALC-GRAPHITE

Talc-Graphite lubricant is to be used for treated seed, providing benefits of both talc and graphite. It absorbs moisture to prevent bridging, minimizes static electricity for improved seed flow, and lubricates seed and meters.

Row Hoppers

Mix ½ C. of 80/20 talc-graphite evenly with seed each time hoppers are filled. Regular graphite use prolongs life of the seed meter components, improves seed spacing, and may reduce buildup of seed treatments.

NOTE: Talc-Graphite lubricant MUST be mixed evenly during fill.

Bulk Fill Hoppers

Mix 8 lbs. of 80/20 talc-graphite each time the bulk seed hopper is filled. Regular graphite use prolongs life of the seed meter components, improves seed spacing, and may reduce buildup of seed treatments.

NOTE: Talc-Graphite lubricant MUST be mixed evenly during fill.

TALC

Talc seed lubricant may be used as a drying agent in addition to graphite lubrication. The drying agent may improve seed release and/or **to retard buildup of seed treatments on meter components.**

1. Fill hopper ½ full of seed, add ¼ cup (conventional); 2 pounds (Bulk Fill) of talc and **mix thoroughly.**
2. Finish filling hopper, add another ¼ cup (conventional); 2 pounds (Bulk Fill) of talc and **mix thoroughly.**
3. Adjust rate of talc use as needed so all seeds are coated, while avoiding a buildup of talc in bottom of hopper.

Humid conditions and/or small sized seeds with extra seed treatment may require additional talc to maintain meter performance.

NOTE: Liquid seed treatments or inoculants may create buildup on the seed disc or brushes. Check frequently for proper population and/or seed delivery when using any liquid seed treatment.

Completely mix all treatments with seed following manufacturers' recommendations. Seed treatment dumped on top of seed after hopper is filled may not mix properly and cause seed bridging, reducing population or stopping meter from planting.

SPIKED CLOSING WHEEL

Spiked closing wheels crumble the sidewall, allowing roots to penetrate soil. They can be used on pull row units and push row units.

Align spiked closing wheels straight across from each other, in most rearward holes on closing wheel arm. Set the wheels 1" - 1 1/4" (~2,5 - 3 cm) apart at the closest point. If large amounts of contouring is being done, mount wheels in the forward most hole. This will reduce drifting of row unit.

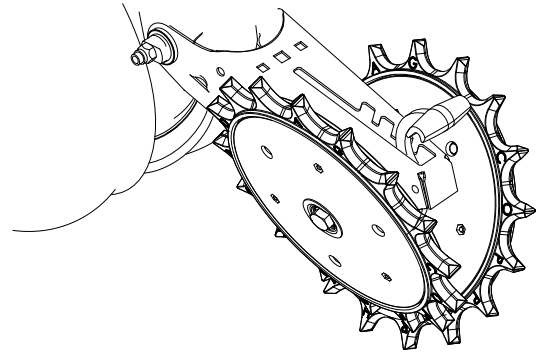

Row Unit Spiked Closing Wheel

ROW UNIT MOUNTED NO TILL COULTER

Row unit mounted no till coulters with 1" (2,5 cm) bubbled, 1" (~2,5 cm) fluted (8 flutes) or 3/4" (~2 cm) fluted (13 flutes) blades may be used on row units (3/4" (~2 cm) fluted shown). Four quick adjustable down force springs are required per row when using row unit mounted no till coulters. See "[Quick Adjustable Down Force Springs Option](#)" on page 3-2.

Coulter blade can be adjusted to one of four 1/2" (~1 cm) incremental settings in the forked arm. Initial location is the top hole.

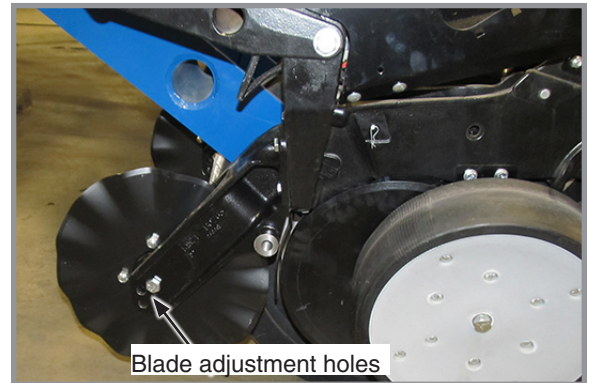

Row Unit Mounted No Till Coulter

Move blade as it wears to one of the three lower hole to maintain coulters blade at or slightly above opener discs. Adjust coulters below depth of double disc opener blades in very hard soil conditions such as compacted wheel tracks to improve opener penetration and cutting of surface residue.

Check operating depth by setting planter down on a level concrete floor and checking relationship between coulters blade and row unit opener blade. Make sure planter is level and coulters is square with planter frame and aligned with row unit disc opener.

NOTE: Torque 5/8" spindle hardware to 163 Nm.

COULTER MOUNTED RESIDUE WHEELS

Coulter mounted residue wheels are designed for use on row units.

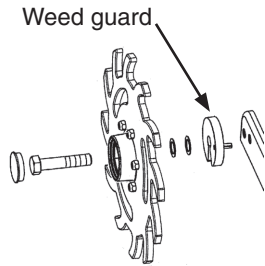

NOTE: Opening in weed guard must face down.



Coulter Mounted Residue Wheels

Residue wheels attach to row unit mounted coulter with two cap screws and sleeves allowing unit to free-float. A 2-position spindle bolt mounting positions wheels interlocked or staggered. Depth adjustment is made with a spring-loaded cam and pin with 11 positions in 1/4" (~0,6 cm) increments. A high point on the cam allows wheels to be locked up.

A weed guard on the inboard side of each wheel helps prevent weed wrap which can cause premature bearing failure.

GRANULAR CHEMICAL BANDING OPTIONS

Granular chemical banding options allow 4 1/2" (~12 cm) slope-compensating banding or straight drop in-furrow placement.

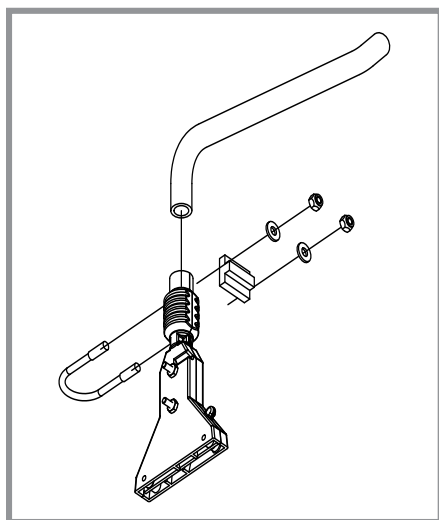

4 1/2" (~12 cm) Slope-compensating Bander

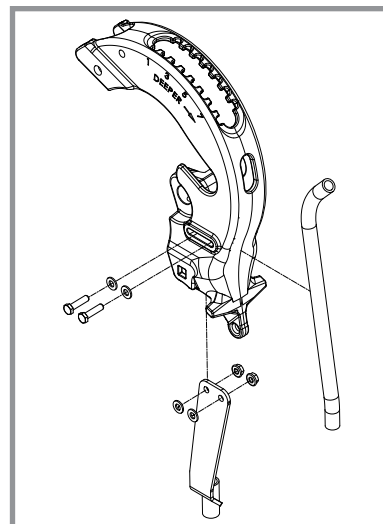

Straight Drop In-furrow Placement

GRANULAR CHEMICAL HOPPER AND DRIVE



WARNING



Agricultural chemicals can cause death or serious injury to persons, animals, and plants or seriously damage soil, equipment, or property. Read and follow all chemical and equipment manufacturers labels and instructions.

NOTICE

Do not store granular products in granular chemical hoppers. High humidity or rain may cause stored granular products to bind and block the product from flowing.

The granular chemical hopper has a 40 l capacity.

Make sure no foreign objects get into hopper when it is being filled. Replace hopper lids after filling to prevent accumulation of dirt and moisture.

A metering gate on bottom of hopper regulates the application rate. See [“Dry Insecticide Application Rates” on page 5-15](#). Calibrate using chemical manufacturers’ instructions.



Granular Chemical Hopper

Granular chemical clutch drive coupler and meter shaft can be disengaged and engaged by turning throw out knob at rear of hopper support panel.

Rotate knob $\frac{1}{4}$ turn counterclockwise to disengage and $\frac{1}{4}$ turn clockwise to engage.

Slotted holes in hopper support panel and clutch housing allow for alignment adjustment between clutch drive coupler and meter shaft.

NOTE: Not applicable with Kinze Blue Vantage system.

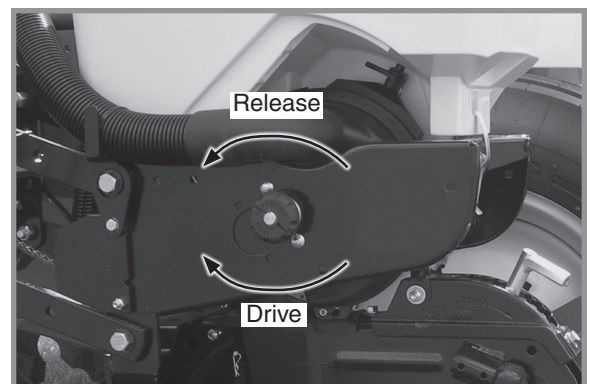

Granular chemical drive release

PREPARING THE SYSTEM FOR OPERATION

To optimize the performance of your applicator, it is best to make all adjustments before operation in the field.

ADJUSTMENTS BEFORE OPERATION

1. If your applicator is equipped with hydraulic gates, ensure that all gates are open and work well.
2. If your applicator is equipped with electronic scale, the monitor has been preset by the manufacturer by kilograms or pounds according to the customer specification. To change the monitor unit, refer to the CALIBRATION PROCEDURE (see "[Calibration Procedure](#)" on page 4-6).



PLANTING CORN CONFIGURATION

1. Make sure that all the gates of the distribution system are open.
2. If your planter is equipped with fertilizer openers, the basic adjustment at the factory is $2\frac{3}{8}$ " (~6 cm) to the side of seed. If necessary adjust the distance of each fertilizer disc relative to the corn row.

To move the fertilizer discs, loosen the nuts on the U-bolts and slide the complete set on the desired side.

Please note that mechanical constraints could affect the lateral movement of the discs.

3. If applicable, also adjust the height of each fertilizer disc to the ground.

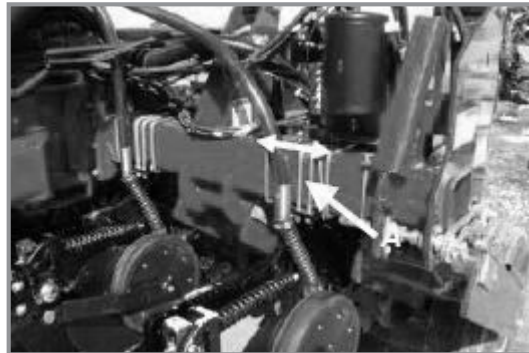

PISTON PUMP

NOTE: Keep manuals shipped with piston pump and flow divider with this manual.

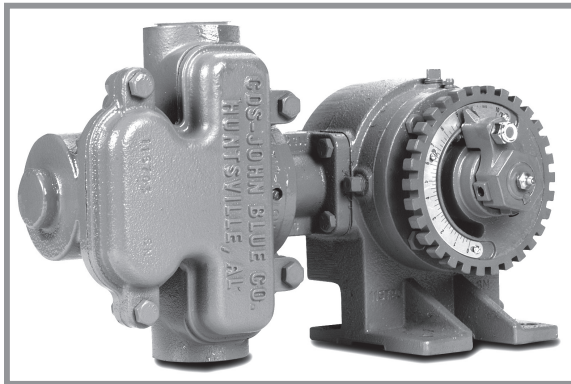

Piston pump

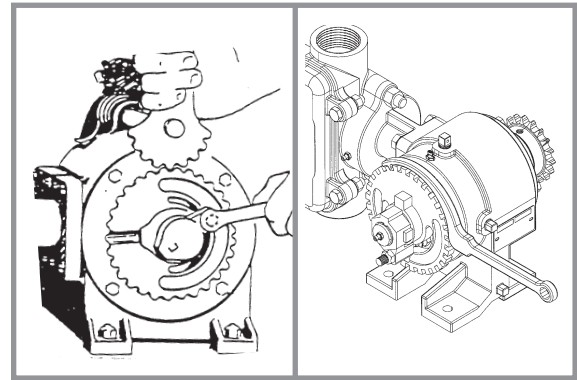

Adjusting delivery rate

NOTE: Delivery rate chart in Rate Chart section of this manual provides approximate application rate only. Delivery varies with temperature and fertilizer.

Loosen $\frac{3}{8}$ " lock nut that secures arm with pointer and rotate scale flange with adjustment wrench until pointer is over desired scale setting. Tighten $\frac{3}{8}$ " lock nut. **DO NOT OVERTIGHTEN.**

NOTE: Periodically check flow to all rows. Set rate is delivered to remaining rows if one or more lines are plugged.

PISTON PUMP GROUND DRIVE WHEEL SPRING ADJUSTMENT

Initial down pressure spring tension on piston pump ground drive wheel, is set leaving $12\frac{1}{4}$ " (~31 cm) between the bottom of mounting plate and plug on top of spring. This dimension is taken with planter raised (tire not contacting the ground). Further adjustment can be made to fit conditions.

NOTE: Piston pump ground drive wheel assembly can be locked in raised position when not in use. Remove two cap screws that attach upper end of spring to spring mount. Reattach spring using upper holes in spring mount. Reverse procedure to reset for field use.

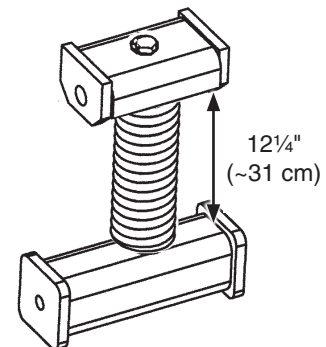

CLEANING

Clean tanks, hoses, and metering pump thoroughly with water at end of planting season or prior to an extended period of non-use. Do not allow fertilizer to crystallize from cold temperature or evaporation.

On machines equipped with piston pump, take apart and clean strainer located between piston pump and ball valve daily. Remove the end cap to clean the screen. See "[Piston Pump Storage](#)" on page 6-26.

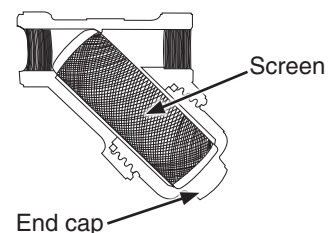

STARTUP PROCEDURE

Carefully take the time to follow all instructions listed in this section in order to benefit from optimal performance from your applicator.

1. Adjust the speed of transmission of the distribution system. Use handle for adjusting the indicator rule to the desired position. As a guide, position 6 is equivalent to approximately 225 kg/ha. (May vary depending on the density)
2. The optimum operating zone of the variable transmission is between 3 and 18 on the indicator rule. If you can not reach your dosage in this field of action, change the sprocket on the metering roll shaft. The sprocket installed by the manufacturer is 16 teeth. Consult the manufacturer to obtain a replacement gear.

If your dosage is too small and the transmission adjustment indicator is more than 18, then you need to change the 16 teeth sprocket for a 12 teeth sprocket. With a smaller sprocket, shaft will rotate faster and increase the application rate.

Refer to CALIBRATION PROCEDURE in this section for the calibration procedure of the applicator.

NOTICE

Maximum recommended dry fertilizer rate is 400kg/ha). Fertilizer rate difference between each row will exceed 10% at higher rates.



STARTUP PROCEDURE (CONTINUED)

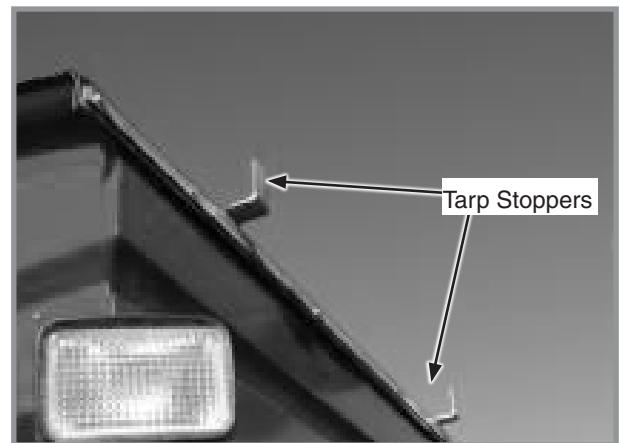

3. If the applicator is equipped with an electronic scale, be sure to press the ZERO / RESET key before filling the hopper.

NOTE: For greater precision calibration, always use the same method. For example, if you take data with tool bar and planter on the ground, always be sure the planter is in the same configuration whenever taking data.

4. To open the tarp of your distributor, turn the tarp wheel clockwise and lift the tarp lock latch. Then release the wheel down. Roll the tarp on itself using the tarp wheel to the tarp stopper at the other end of the hopper.
5. To close the tarp, turn the tarp over itself in the opposite direction. Align the tarp on the hopper. Stretch the fabric by turning the tarp wheel while keeping the lock in the teeth of the grooved gear.
6. Before initial filling of the hopper, you must ensure that hopper screens are install in the hopper and that no objects or debris are on hopper screen.

 WARNING	<p>Transporting planter with hoppers over half full or unevenly loaded can cause loss of control and could result in death, serious injury, or damage to property and equipment. Properly load planter when transporting. Be aware of extra transport weight, and road conditions and limits.</p>
--	---

PTO PUMP DRIVE STARTUP PROCEDURE

1. While the engine is running at low speed, start the tractor PTO.
2. Increase the speed of the PTO gradually to a minimum of 800 RPM.
3. If your applicator is equipped with electronic scale, make sure to take note of the weight reading and working area for future calibration.
4. Lower down planter to the ground. Always make sure there is enough space around the planter to perform various operations.
5. Start planting, while increasing the speed of the PTO to 1000 rpm. The pressure indicated on the pressure gauge should be between 5,2 - 6,2 kPa (21 - 25 in of water (~53-64 cm of water)) for a fan REM HE and between 74,7 - 89,6 kPa (30 - 36 in of water (~76-91 cm of water)) for an applicator equipped with a REM BC172CW fan. The fan REM HE should run at 5000 RPM when the tractor reaches 1000 RPM to the power take off. The fan REM BC172CW should run at 4500 RPM when the tractor reaches 1000 RPM to the power take off. The fan system was calibrated to reach its full potential at 1000 RPM. It is very important to respect these data to get the best efficiency from your distributor.
6. Always make sure there is no blockage or obstruction in the fertilizer distribution system.
7. Stop to verify the depth of the fertilizer and its positioning relative to the seed. To make corrections, if necessary, refer to ["Preparing the System for Operation" on page 4-1](#).
8. Make regular visual inspection of the distribution system, metering shaft and air box. Clean the metering roll splines, if necessary, with the scraper designed for this purpose. If the PTO speed is not sufficient when the applicator is in movement, the flow of material could be too large and cause a blockage in the hose. Always keep hopper screens in place for a good functioning of the distribution system.

CALIBRATION PROCEDURE

Contact Drive Wheel Circumference: 50.79" (~129 cm)

1 ha: 10.000m²

FOR APPLICATOR WITHOUT ELECTRONIC SCALE:

1. Open the gate and install the calibration pan under the metering system.
2. Turn the contact drive wheel constantly for 10 rotations OR use the hand crank and turn for 28 rotations.
3. Weigh the amount of fertilizer collected in the pan in kilograms.
4. Multiply by the calibration factor of 45.787 to obtain the application rate in kilograms per hectare.
5. Adjust the transmission and repeat steps 2 - 4 if necessary.

FOR APPLICATOR WITH ELECTRONIC SCALE:

1. Note the initial scale number.
2. Apply fertilizer on hectare in field.
3. Subtract the number on the scale from the number applied to the field. This is the application rate at which the transmission is now adjusted.
4. Adjust the transmission and repeat steps 1 - 3 if necessary.

NOTCHED SINGLE DISC OPENERS

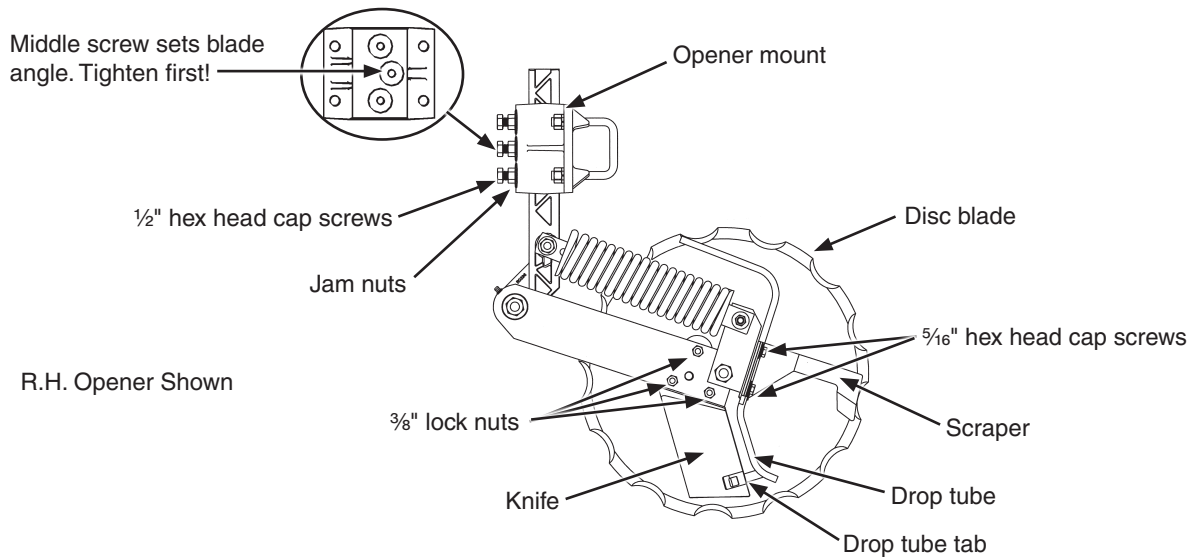

Notched single disc opener adjustments



CAUTION Compressed spring may fly out of this assembly if attempting to disassemble and cause injury. Do not take apart this assembly.

Disc blades are sharp and can cut causing serious injury. Wear gloves when working on or turning disc blades by hand.



NOTICE Never strike knife with heavy object. Damage to knife will occur.

If knife to disc blade clearance is too large, soil or residue can wedge between knife and blade, and blade will not turn.

1. Adjust knife to disc blade contact. Loosen or tighten $\frac{3}{8}$ " lock nuts to adjust knife's entire leading edge against disc blade. Turn blade and check for slight resistance without freewheeling. Readjust knife to blade's tight spot as needed.

NOTICE

Adjust liquid drop tube out of path of soil flow across knife. Drop tube and tab wear quickly if not correctly adjusted.

2. Adjust scraper and drop tube. Loosen two $\frac{5}{16}$ " hex head cap screws. Adjust scraper until just touching disc blade. Adjust drop tube until it is centered between knife and disc blade. Tighten screws. Turn blade and check for slight resistance without freewheeling. Repeat as needed. Insert flat bladed pry bar or screwdriver between knife and drop tube above drop tube tab. Carefully bend tube until $\frac{1}{4}$ "- $\frac{3}{8}$ " (~0,6 - 1 cm) from disc blade.

NOTE: Maximum disc blade depth 4" (~10 cm).

3. Adjust blade depth. Loosen three $\frac{1}{2}$ " hex head cap screws and jam nuts in opener mount. Adjust opener assembly up or down to desired blade depth. Tighten center hex head cap screw and jam nut first to set proper disc blade angle. Tighten remaining hex head cap screws and jam nuts. Torque hex head cap screws and jam nuts to 57 ft-lb (~77 Nm). Check fertilizer hose clearance and adjust as necessary.

DEPTH/GAUGE WHEEL ATTACHMENT FOR NOTCHED SINGLE DISC FERTILIZER OPENER

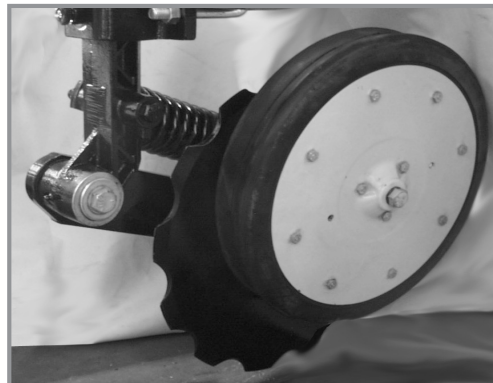

Notched single disc opener depth/gauge wheel

Depth/gauge wheel attachment for notched single disc fertilizer opener is used where additional gauging is required to maintain desired fertilizer opener depth. Depth/gauge wheel is attached to notched single disc fertilizer opener using a mounting block fastened to the pivot arm with $\frac{5}{8}$ " hardware through disc blade bearing.

Depth adjustment is made using 3 adjustment holes in depth/gauge wheel mounting block. Moving depth/gauge wheel increases/decreases depth in approximate 1" (~2,5 cm) increments in relation to blade depth setting made at vertical mounting post.

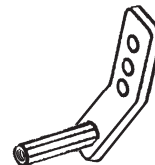

LIQUID FERTILIZER ATTACHMENT **WARNING**

Agricultural chemicals can cause death or serious injury to persons, animals, and plants or seriously damage soil, equipment, or property. Read and follow all chemical and equipment manufacturers labels and instructions.

 **CAUTION**

Overfilling tank can cause siphoning, tank collapse, personal injury, and damage to property and equipment. Do not overfill tank. Do not leave planter unattended when filling tank. Close fill valve and open tank lid if siphoning occurs. Follow all chemical manufacturers first aid, cleanup, and handling instructions.

NOTICE

Placing fertilizer too close to seeds or in excessive amounts can cause germination or seedling damage. Check with your fertilizer dealer or manufacturer for correct amount and placement.



Kinze 4805 24 Row 70 CM Planter W/ Liquid Fertilizer & Bulk Fill

SYSTEM OVERVIEW

Fertilizer is controlled through the Blue Vantage Display. You can increase or decrease fertilizer rate, turn fertilizer function on or off, and load a prescription. Refer to your Advanced Blue Vantage manual for more information.

CENTRIFUGAL PUMP

Note: Keep manuals shipped with centrifugal pump with this manual.

The centrifugal pump operates off of hydraulics from the bulk fill remote, which can be identified by yellow label hoses. It uses a common rail delivery system with orifice and control valve to achieve desired fertilizer rate. The fertilizer pump is factory set and has a hydraulic requirement of 4 GPM (~15 l/min).

Operating pressure while operating in the field should be 30-40 PSI. The orifice size installed in the factory is 0.037". If a different rate or travel speed is desired, use rate chart and install orifices for your rate.

The centrifugal pump should be running when:

- Bulk Fill remote is on (identified by yellow hoses)
- Blue Vantage system must be in a task before pump will start
- Fertilizer is turned on in the fertilizer section of your Blue Vantage system.

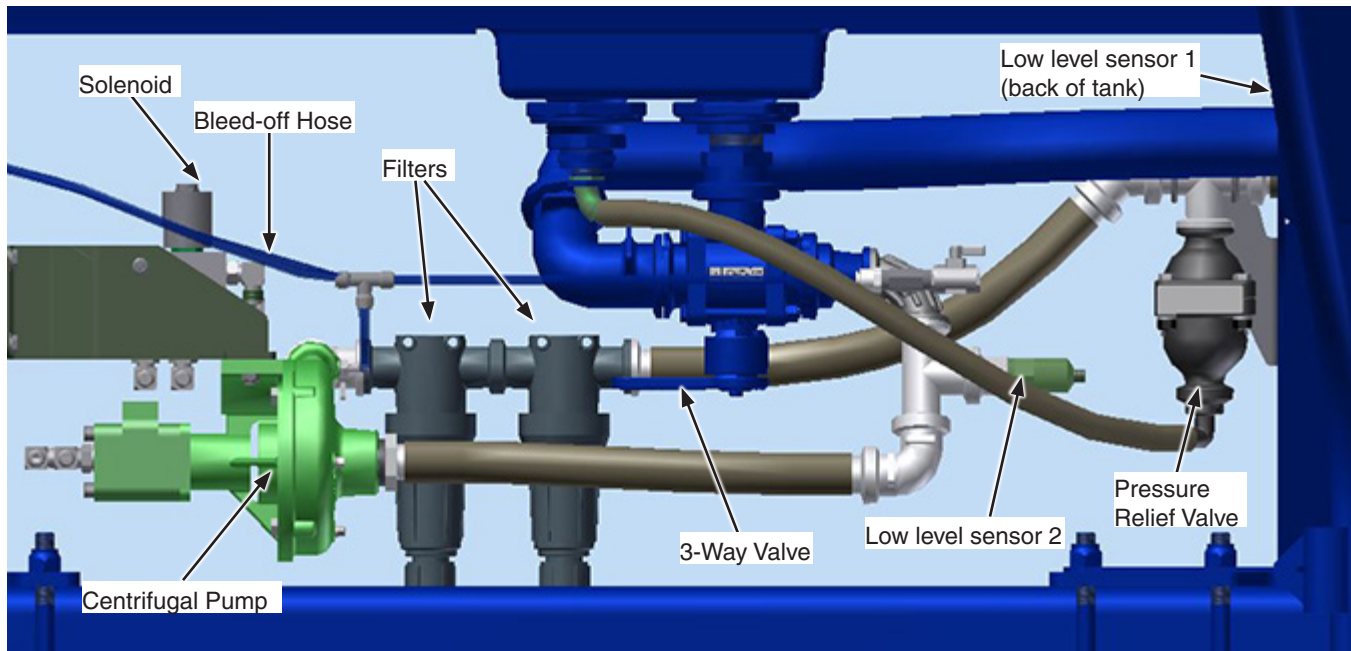

Underneath Fertilizer Tank

Solenoid allows oil to go to centrifugal pump and turn. It is controlled from the Master Module on the planter.

Safety Relay (not shown) shuts off the pump when no fluid is sensed in the lower Low Level Sensor.

Low Level Sensor 1 is located on back of tank and signals in the cab when tank fluid level is low.

Low Level Sensor 2 is located in the tee fitting after 3-way valve and prevents pump from running when fluid level in tank is too low.

Centrifugal Pump is hydraulically driven and pumps fertilizer to the manifold rail delivery system.

3-Way Valve has three positions for filling the tank. Use the “FILL” position to fill the tank. Use the “PUMP” position while operating. “OFF” turns the tank off.

Pressure Relief Valve is a 100 psi (689 kPa) relief valve that allows liquid to return to the tank when valves are shut off on all rows.

Bleed-off Hose is used for preventing or eliminating air-locking the centrifugal pump.

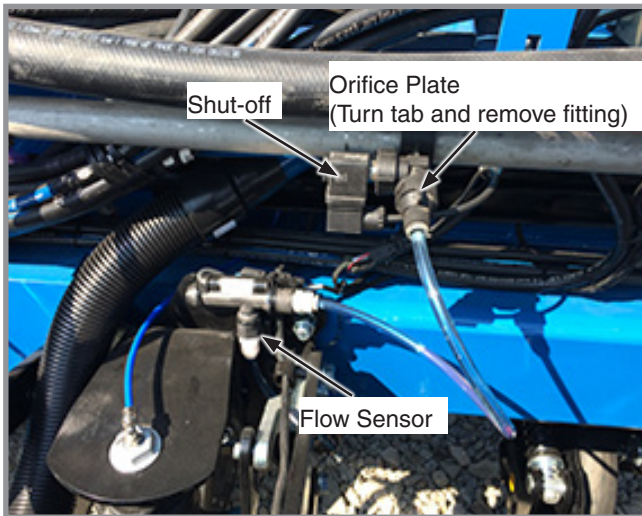

On Toolbar at Row

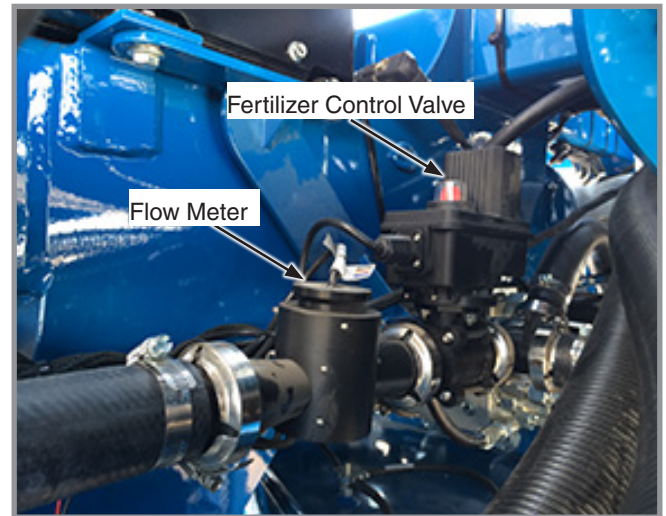

Underneath Bulk Fill Tank

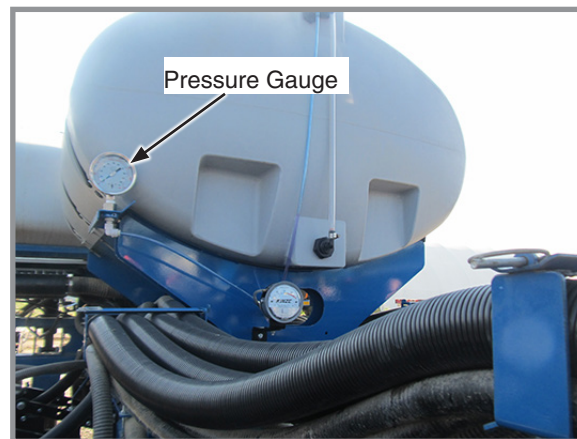

Flow Meter measures fertilizer rate when operating in the field and is displayed in the tractor cab.

Fertilizer Control Valve controls the fertilizer rate and changes rate with change in speed from input from the flow meter.

Shut-off 24 volt shut-off stops fertilizer when coming into a planted area.

Flow Sensor functions as a blockage sensor to signal operator when there is a blockage or no fertilizer flow when there should be. Flow sensor does not indicate rate.

Orifice Plate is factory installed with a 0.037" diameter. To access the orifice, turn the tab counterclockwise and remove the fitting and tube.

Pressure Gauge is located on the tank. On some models, the pressure gauge may be located on the end of the toolbar.

CHECK VALVES



Low rate check valves are provided for in-line installation between liquid fertilizer piston pump and openers or in-furrow to ensure equal distribution of product at low rates and siphon protection for field turns. Check valves eliminate the need for anti-siphon loops.

REAR TRAILER HITCH OPTION



Trailer Hitch

Rear trailer hitch is used to tow a 3 or 4 wheel wagon behind planter. Hitch height during field operation and transport is 15" (~38 cm). Hitch height will raise to approximately 42" (~107 cm) when planter is lifted.

NOTICE

Rear trailer hitch is designed for use with piston pump only. Maximum allowable hitch weight is 200 lb (~91 kg). Do not exceed 6000 lb (~2722 kg) gross towing weight or the equivalent of a loaded 500 gal (~1893 l) tank and running gear or equipment can be damaged.

NOTE: Periodically check feed hose for kinks to prevent restricted delivery rate.

Adjust rear trailer hitch length by loosening the $\frac{5}{8}$ " set screws at rear of outer tube, removing 1" x 8 $\frac{1}{2}$ " bolt at center of hitch, and sliding hitch in or out to one of 4 sets of adjustment holes. Reinstall and tighten hardware.

NOTICE

After fertilizer use, the planter must be cleaned to prevent fertilizer related rust on the frame and in the system.

This page left blank intentionally.

GENERAL PLANTING RATE INFORMATION

These planting rate charts apply to KINZE Model 4805 ground contact drive planters (Ag Leader).

For Blue Drive 4805 planters, see M0288 Blue Vantage Operator's Manual.

For True Speed 4805 planters, see M0308 True Speed Operator's Manual.

NOTICE

Sprocket combinations in these charts are for average conditions. Changes in sprocket combinations may be required for desired planting population. **ALWAYS MAKE FIELD CHECKS TO BE SURE YOU ARE PLANTING AT THE DESIRED RATE.**

NOTE: Seed size and shape may affect planting rate.

NOTE: Not all row spacings listed apply to all size planters.

NOTE: Speeds above 10 km/h can adversely affect seed spacing.

NOTE: Planting speed can affect actual seeding rate. Make a field check and adjust transmission setting to obtain desired seed drop.

NOTE: 15, 22, and 28 tooth drive sprockets are NOT applicable to all rate charts. Check chart titles to ensure proper rate chart is selected.

22 tooth sprockets require use of 148 pitch No. 40 chains.

28 tooth sprockets require use of 150 pitch No. 40 chains.

**VACUUM PLANTING RATES FOR CORN / SUNFLOWER 40 CELL DISC
15 TOOTH CONTACT WHEEL DRIVE SPROCKET
APPROXIMATE SEEDS / HECTARE FOR 70 CM ROWS**

70 cm Rows	Transmission Sprockets		Recomm. Speed Range (km/h)	Average Seed Spacing (cm)
	Drive	Driven		
40747	15	30	6 to 10	35,1
43657	15	28	6 to 10	32,7
45274	15	27	6 to 10	31,6
47014	15	26	6 to 10	30,4
48895	15	25	6 to 10	29,2
49478	17	28	6 to 10	28,9
50934	15	24	6 to 10	28,0
51310	17	27	6 to 10	27,8
53147	15	23	6 to 10	26,9
53285	17	26	6 to 10	26,8
55299	19	28	6 to 10	25,8
55415	17	25	6 to 10	25,8
57346	19	27	6 to 10	24,9
57723	17	24	6 to 10	24,7
59552	19	26	6 to 10	24,0
60233	17	23	6 to 10	23,7
61935	19	25	6 to 10	23,1
64337	15	19	6 to 10	22,2
64515	19	24	6 to 10	22,1
66941	23	28	6 to 10	21,3
67321	19	23	6 to 10	21,2
69419	23	27	6 to 10	20,6
69852	24	28	6 to 10	20,5
71904	15	17	6 to 10	19,9
72437	24	27	6 to 10	19,7
72916	17	19	6 to 10	19,6
74973	23	25	6 to 10	19,1
75673	26	28	6 to 10	18,9
78096	23	24	6 to 10	18,3
78234	24	25	6 to 10	18,3
78583	27	28	6 to 10	18,2
81494	23	23	6 to 10	17,5
84512	28	27	6 to 10	16,9
84628	27	26	6 to 10	16,9
85036	24	23	6 to 10	16,8
87761	28	26	6 to 10	16,3
88011	27	25	6 to 10	16,2
88579	25	23	6 to 10	16,1
91081	19	17	6 to 10	15,7
91680	27	24	6 to 10	15,6
92122	26	23	6 to 10	15,5
95075	28	24	6 to 10	15,0
95664	27	23	6 to 10	14,9
98650	23	19	6 to 10	14,5
99210	28	23	6 to 10	14,4
102938	24	19	6 to 10	13,9
107228	25	19	6 to 10	13,3
110254	23	17	6 to 10	13,0
111516	26	19	6 to 10	12,8
115048	24	17	6 to 10	12,4
115806	27	19	6 to 10	12,3
119841	25	17	6 to 10	11,9
120094	28	19	6 to 10	11,9
124637	26	17	6 to 10	11,5
124955	23	15	6 to 10	11,4
129431	27	17	6 to 10	11,0

NOTE: See ["General Planting Rate Information"](#) on page 5-1 and ["Field Check Seed Population"](#) on page 2-44" for additional information. Always check seed population in the field to ensure planting rates are correct.

**VACUUM PLANTING RATES FOR CORN /SUNFLOWER 40 CELL DISC
22 TOOTH CONTACT WHEEL DRIVE SPROCKET
APPROXIMATE SEEDS / HECTARE FOR 70 CM ROWS**

70 cm Rows	Transmission Sprockets		Recomm. Speed Range (km/h)	Average Seed Spacing (cm)
	Drive	Driven		
59762	15	30	6 to 10	23,9
64031	15	28	6 to 10	22,3
66401	15	27	6 to 10	21,5
68956	15	26	6 to 10	20,7
71716	15	25	6 to 10	19,9
72566	17	28	6 to 10	19,7
74702	15	24	6 to 10	19,1
75253	17	27	6 to 10	19,0
77948	15	23	6 to 10	18,3
78148	17	26	6 to 10	18,3
81106	19	28	6 to 10	17,6
81276	17	25	6 to 10	17,6
84108	19	27	6 to 10	17,0
84662	17	24	6 to 10	16,9
87344	19	26	6 to 10	16,4
88342	17	23	6 to 10	16,2
90836	19	25	6 to 10	15,7
94360	15	19	6 to 10	15,1
94621	19	24	6 to 10	15,1
98179	23	28	6 to 10	14,6
98736	19	23	6 to 10	14,5
101816	23	27	6 to 10	14,0
102448	24	28	6 to 10	13,9
105461	15	17	6 to 10	13,5
106241	24	27	6 to 10	13,4
106943	17	19	6 to 10	13,4
109961	23	25	6 to 10	13,0
110983	26	28	6 to 10	12,9
114545	23	24	6 to 10	12,5
114741	24	25	6 to 10	12,5
115255	27	28	6 to 10	12,4
119524	23	23	6 to 10	12,0
123949	28	27	6 to 10	11,5
124121	27	26	6 to 10	11,5
124718	24	23	6 to 10	11,5
128715	28	26	6 to 10	11,1
129086	27	25	6 to 10	11,1
129915	25	23	6 to 10	11,0
133587	19	17	6 to 10	10,7
134464	27	24	6 to 10	10,6
135115	26	23	6 to 10	10,6
139443	28	24	6 to 10	10,2
140309	27	23	6 to 10	10,2
144685	23	19	6 to 10	9,9
145506	28	23	6 to 10	9,8
150977	24	19	6 to 10	9,5
157269	25	19	6 to 10	9,1
161707	23	17	6 to 10	8,8
163558	26	19	6 to 10	8,7
168739	24	17	6 to 10	8,5
169850	27	19	6 to 10	8,4
175770	25	17	6 to 10	8,1
176139	28	19	6 to 10	8,1
182799	26	17	6 to 10	7,8
183267	23	15	6 to 10	7,8
189830	27	17	6 to 10	7,5

NOTE: See ["General Planting Rate Information"](#) on page 5-1 and ["Field Check Seed Population"](#) on page 2-44" for additional information.

**VACUUM PLANTING RATES FOR CORN / SUNFLOWER 40 CELL DISC
28 TOOTH CONTACT WHEEL DRIVE SPROCKET
APPROXIMATE SEEDS / HECTARE FOR 70 CM ROWS**

70 cm Rows	Transmission Sprockets		Recomm, Speed Range (km/h)	Average Seed Spacing (cm)
	Drive	Driven		
76058	15	30	6 to 10	18,8
81491	15	28	6 to 10	17,5
84509	15	27	6 to 10	16,9
87761	15	26	6 to 10	16,3
91272	15	25	6 to 10	15,7
92358	17	28	6 to 10	15,5
95075	15	24	6 to 10	15,0
95780	17	27	6 to 10	14,9
99210	15	23	6 to 10	14,4
99462	17	26	6 to 10	14,4
103223	19	28	6 to 10	13,8
103441	17	25	6 to 10	13,8
107048	19	27	6 to 10	13,3
107750	17	24	6 to 10	13,3
111164	19	26	6 to 10	12,9
112436	17	23	6 to 10	12,7
115610	19	25	6 to 10	12,4
120094	15	19	6 to 10	11,9
120428	19	24	6 to 10	11,9
124955	23	28	6 to 10	11,4
125665	19	23	6 to 10	11,4
129584	23	27	6 to 10	11,0
130388	24	28	6 to 10	11,0
134222	15	17	6 to 10	10,6
135220	24	27	6 to 10	10,6
136107	17	19	6 to 10	10,5
139951	23	25	6 to 10	10,2
141256	26	28	6 to 10	10,1
145783	23	24	6 to 10	9,8
146036	24	25	6 to 10	9,8
146687	27	28	6 to 10	9,7
152120	23	23	6 to 10	9,4
157753	28	27	6 to 10	9,1
157971	27	26	6 to 10	9,0
158732	24	23	6 to 10	9,0
163824	28	26	6 to 10	8,7
164289	27	25	6 to 10	8,7
165349	25	23	6 to 10	8,6
170016	19	17	6 to 10	8,4
171135	27	24	6 to 10	8,3
171961	26	23	6 to 10	8,3
177473	28	24	6 to 10	8,0
178576	27	23	6 to 10	8,0
184144	23	19	6 to 10	7,8
185190	28	23	6 to 10	7,7
192152	24	19	6 to 10	7,4
200157	25	19	6 to 10	7,1
205811	23	17	6 to 10	6,9
208165	26	19	6 to 10	6,9
214758	24	17	6 to 10	6,7
216170	27	19	6 to 10	6,6
223707	25	17	6 to 10	6,4
224175	28	19	6 to 10	6,4
232654	26	17	6 to 10	6,1
233251	23	15	6 to 10	6,1
241600	27	17	6 to 10	5,9

NOTE: See ["General Planting Rate Information"](#) on page 5-1 and ["Field Check Seed Population"](#) on page 2-44" for additional information Always field check seed population to verify planting rates.

**VACUUM PLANTING RATES FOR SUGAR BEET / MILO / SPECIALTY 60 CELL DISC
15 TOOTH CONTACT WHEEL DRIVE SPROCKET
APPROXIMATE SEEDS / HECTARE FOR 70 CM ROWS**

70 cm Rows	Transmission Sprockets		Recomm. Speed Range (km/h)	Average Seed Spacing (cm)
	Drive	Driven		
61120	15	30	6 to 10	23,4
65486	15	28	6 to 10	21,8
67910	15	27	6 to 10	21,0
70522	15	26	6 to 10	20,3
73343	15	25	6 to 10	19,5
74218	17	28	6 to 10	19,2
76399	15	24	6 to 10	18,7
76967	17	27	6 to 10	18,6
79721	15	23	6 to 10	17,9
79926	17	26	6 to 10	17,9
82949	19	28	6 to 10	17,2
83124	17	25	6 to 10	17,2
86021	19	27	6 to 10	16,6
86586	17	24	6 to 10	16,5
89330	19	26	6 to 10	16,0
90352	17	23	6 to 10	15,8
92902	19	25	6 to 10	15,4
96504	15	19	6 to 10	14,8
96773	19	24	6 to 10	14,8
100412	23	28	6 to 10	14,2
100980	19	23	6 to 10	14,1
104129	23	27	6 to 10	13,7
104778	24	28	6 to 10	13,6
107858	15	17	6 to 10	13,2
108657	24	27	6 to 10	13,1
109372	17	19	6 to 10	13,1
112460	23	25	6 to 10	12,7
113509	26	28	6 to 10	12,6
117146	23	24	6 to 10	12,2
117350	24	25	6 to 10	12,2
117872	27	28	6 to 10	12,1
122238	23	23	6 to 10	11,7
126768	28	27	6 to 10	11,3
126940	27	26	6 to 10	11,3
127553	24	23	6 to 10	11,2
131642	28	26	6 to 10	10,9
132019	27	25	6 to 10	10,8
132869	25	23	6 to 10	10,8
136621	19	17	6 to 10	10,5
137519	27	24	6 to 10	10,4
138184	26	23	6 to 10	10,3
142611	28	24	6 to 10	10,0
143499	27	23	6 to 10	10,0
147975	23	19	6 to 10	9,7
148812	28	23	6 to 10	9,6
154407	24	19	6 to 10	9,3
160841	25	19	6 to 10	8,9
165382	23	17	6 to 10	8,6
167275	26	19	6 to 10	8,5
172572	24	17	6 to 10	8,3
173710	27	19	6 to 10	8,2
179765	25	17	6 to 10	7,9
180141	28	19	6 to 10	7,9
186955	26	17	6 to 10	7,6
187434	23	15	6 to 10	7,6
194145	27	17	6 to 10	7,4

NOTE: See ["General Planting Rate Information"](#) on page 5-1 and ["Field Check Seed Population"](#) on page 2-44" for additional information Always field check seed population to verify planting rates.

VACUUM PLANTING RATES FOR MILO/SUGAR BEET/SPECIALTY 60 CELL DISCS
22 TOOTH CONTACT WHEEL DRIVE SPROCKET
APPROXIMATE SEEDS / HECTARE FOR 70 CM ROWS

70 cm Rows	Transmission Sprockets Drive	Driven	Recomm, Speed Range (km/h)	Average Seed Spacing (cm)
89643	15	30	6 to 10	15,9
96046	15	28	6 to 10	14,9
99602	15	27	6 to 10	14,3
103433	15	26	6 to 10	13,8
107570	15	25	6 to 10	13,3
108850	17	28	6 to 10	13,1
112054	15	24	6 to 10	12,7
112882	17	27	6 to 10	12,7
116925	15	23	6 to 10	12,2
117224	17	26	6 to 10	12,2
121657	19	28	6 to 10	11,7
121912	17	25	6 to 10	11,7
126163	19	27	6 to 10	11,3
126994	17	24	6 to 10	11,2
131015	19	26	6 to 10	10,9
132513	17	23	6 to 10	10,8
136255	19	25	6 to 10	10,5
141541	15	19	6 to 10	10,1
141934	19	24	6 to 10	10,1
147270	23	28	6 to 10	9,7
148104	19	23	6 to 10	9,6
152723	23	27	6 to 10	9,4
153672	24	28	6 to 10	9,3
158191	15	17	6 to 10	9,0
159364	24	27	6 to 10	9,0
160413	17	19	6 to 10	8,9
164940	23	25	6 to 10	8,7
166479	26	28	6 to 10	8,6
171813	23	24	6 to 10	8,3
172114	24	25	6 to 10	8,3
172881	27	28	6 to 10	8,3
179286	23	23	6 to 10	8,0
185924	28	27	6 to 10	7,7
186180	27	26	6 to 10	7,7
187078	24	23	6 to 10	7,6
193077	28	26	6 to 10	7,4
193628	27	25	6 to 10	7,4
194874	25	23	6 to 10	7,3
200377	19	17	6 to 10	7,1
201695	27	24	6 to 10	7,1
202669	26	23	6 to 10	7,0
209165	28	24	6 to 10	6,8
210465	27	23	6 to 10	6,8
217028	23	19	6 to 10	6,6
218260	28	23	6 to 10	6,5
226464	24	19	6 to 10	6,3
235900	25	19	6 to 10	6,1
242561	23	17	6 to 10	5,9
245337	26	19	6 to 10	5,8
253108	24	17	6 to 10	5,6
254773	27	19	6 to 10	5,6
263652	25	17	6 to 10	5,4
264209	28	19	6 to 10	5,4
274200	26	17	6 to 10	5,2
274902	23	15	6 to 10	5,2
284747	27	17	6 to 10	5,0

NOTE: See "General Planting Rate Information" on page 5-1 and "Field Check Seed Population" on page 2-44" for additional information Always field check seed population to verify planting rates.

VACUUM PLANTING RATES FOR MILO/SUGAR BEET/SPECIALTY 60 CELL DISCS
28 TOOTH CONTACT WHEEL DRIVE SPROCKET
APPROXIMATE SEEDS / HECTARE FOR 70 CM ROWS

70 cm Rows	Transmission Sprockets		Recomm, Speed Range (km/h)	Average Seed Spacing (cm)
	Drive	Driven		
114091	15	30	6 to 10	12,5
122241	15	28	6 to 10	11,7
126768	15	27	6 to 10	11,3
131642	15	26	6 to 10	10,9
136909	15	25	6 to 10	10,4
138539	17	28	6 to 10	10,3
142611	15	24	6 to 10	10,0
143669	17	27	6 to 10	9,9
148814	15	23	6 to 10	9,6
149194	17	26	6 to 10	9,6
154837	19	28	6 to 10	9,2
155163	17	25	6 to 10	9,2
160572	19	27	6 to 10	8,9
161626	17	24	6 to 10	8,8
166748	19	26	6 to 10	8,6
168655	17	23	6 to 10	8,5
173416	19	25	6 to 10	8,2
180141	15	19	6 to 10	7,9
180641	19	24	6 to 10	7,9
187434	23	28	6 to 10	7,6
188496	19	23	6 to 10	7,6
194376	23	27	6 to 10	7,3
195584	24	28	6 to 10	7,3
201335	15	17	6 to 10	7,1
202828	24	27	6 to 10	7,0
204162	17	19	6 to 10	7,0
209927	23	25	6 to 10	6,8
211882	26	28	6 to 10	6,7
218672	23	24	6 to 10	6,5
219054	24	25	6 to 10	6,5
220030	27	28	6 to 10	6,5
228180	23	23	6 to 10	6,3
236632	28	27	6 to 10	6,0
236958	27	26	6 to 10	6,0
238101	24	23	6 to 10	6,0
245732	28	26	6 to 10	5,8
246434	27	25	6 to 10	5,8
248021	25	23	6 to 10	5,8
255026	19	17	6 to 10	5,6
256702	27	24	6 to 10	5,6
257942	26	23	6 to 10	5,5
266210	28	24	6 to 10	5,4
267865	27	23	6 to 10	5,3
276217	23	19	6 to 10	5,2
277785	28	23	6 to 10	5,1
288227	24	19	6 to 10	5,0
300238	25	19	6 to 10	4,8
308714	23	17	6 to 10	4,6
312246	26	19	6 to 10	4,6
322137	24	17	6 to 10	4,4
324256	27	19	6 to 10	4,4
335559	25	17	6 to 10	4,3
336267	28	19	6 to 10	4,2
348982	26	17	6 to 10	4,1
349878	23	15	6 to 10	4,1
362405	27	17	6 to 10	3,9

NOTE: See ["General Planting Rate Information"](#) on page 5-1 and ["Field Check Seed Population"](#) on page 2-44" for additional information Always field check seed population to verify planting rates.

VACUUM PLANTING RATES FOR MILO/SUGAR BEET/SPECIALTY 60 CELL DISCS
44 TOOTH CONTACT WHEEL DRIVE SPROCKET
APPROXIMATE SEEDS / HECTARE FOR 70 CM ROWS

70 cm Rows	Transmission Drive	Sprockets Driven	Recomm, Speed Range (km/h)	Average Seed Spacing (cm)
179271	15	30	6 to 10	8,0
192076	15	28	6 to 10	7,4
199191	15	27	6 to 10	7,2
206852	15	26	6 to 10	6,9
215126	15	25	6 to 10	6,6
217687	17	28	6 to 10	6,6
224092	15	24	6 to 10	6,4
225751	17	27	6 to 10	6,3
233835	15	23	6 to 10	6,1
234434	17	26	6 to 10	6,1
243298	19	28	6 to 10	5,9
243812	17	25	6 to 10	5,9
252309	19	27	6 to 10	5,7
253969	17	24	6 to 10	5,6
262014	19	26	6 to 10	5,5
265011	17	23	6 to 10	5,4
272494	19	25	6 to 10	5,2
283063	15	19	6 to 10	5,0
283848	19	24	6 to 10	5,0
294519	23	28	6 to 10	4,9
296190	19	23	6 to 10	4,8
305427	23	27	6 to 10	4,7
307323	24	28	6 to 10	4,6
316364	15	17	6 to 10	4,5
318707	24	27	6 to 10	4,5
320802	17	19	6 to 10	4,5
329862	23	25	6 to 10	4,3
332934	26	28	6 to 10	4,3
343605	23	24	6 to 10	4,2
344202	24	25	6 to 10	4,2
345741	27	28	6 to 10	4,1
358545	23	23	6 to 10	4,0
371825	28	27	6 to 10	3,8
372336	27	26	6 to 10	3,8
374133	24	23	6 to 10	3,8
386124	28	26	6 to 10	3,7
387227	27	25	6 to 10	3,7
389723	25	23	6 to 10	3,7
400725	19	17	6 to 10	3,6
403364	27	24	6 to 10	3,5
405312	26	23	6 to 10	3,5
418301	28	24	6 to 10	3,4
420900	27	23	6 to 10	3,4
434029	23	19	6 to 10	3,3
436490	28	23	6 to 10	3,3
452899	24	19	6 to 10	3,2
471769	25	19	6 to 10	3,0
485089	23	17	6 to 10	2,9
490641	26	19	6 to 10	2,9
506181	24	17	6 to 10	2,8
509511	27	19	6 to 10	2,8
527272	25	17	6 to 10	2,7
528381	28	19	6 to 10	2,7
548361	26	17	6 to 10	2,6
549768	23	15	6 to 10	2,6
569453	27	17	6 to 10	2,5

NOTE: See ["General Planting Rate Information"](#) on page 5-1 and ["Field Check Seed Population"](#) on page 2-44" for additional information Always field check seed population to verify planting rates.

**VACUUM PLANTING RATES FOR SOYBEAN 120 CELL DISC
22 TOOTH CONTACT WHEEL DRIVE SPROCKET
APPROXIMATE SEEDS / HECTARE FOR 70 CM ROWS**

70 cm Rows	Transmission Sprockets		Recomm, Speed Range (km/h)	Average Seed Spacing (cm)
	Drive	Driven		
192090	15	28	6 to 10	7,4
199205	15	27	6 to 10	7,2
206865	15	26	6 to 10	6,9
215142	15	25	6 to 10	6,6
217703	17	28	6 to 10	6,6
224105	15	24	6 to 10	6,4
225765	17	27	6 to 10	6,3
233848	15	23	6 to 10	6,1
234448	17	26	6 to 10	6,1
243314	19	28	6 to 10	5,9
243828	17	25	6 to 10	5,9
252325	19	27	6 to 10	5,7
253987	17	24	6 to 10	5,6
262030	19	26	6 to 10	5,5
265030	17	23	6 to 10	5,4
272513	19	25	6 to 10	5,2
283082	15	19	6 to 10	5,0
283867	19	24	6 to 10	5,0
294538	23	28	6 to 10	4,9
296208	19	23	6 to 10	4,8
305448	23	27	6 to 10	4,7
307345	24	28	6 to 10	4,6
316386	15	17	6 to 10	4,5
318728	24	27	6 to 10	4,5
320824	17	19	6 to 10	4,5
329884	23	25	6 to 10	4,3
332958	26	28	6 to 10	4,3
343629	23	24	6 to 10	4,2
344226	24	25	6 to 10	4,2
345762	27	28	6 to 10	4,1
358569	23	23	6 to 10	4,0
371849	28	27	6 to 10	3,8
372360	27	26	6 to 10	3,8
374160	24	23	6 to 10	3,8
386151	28	26	6 to 10	3,7
387254	27	25	6 to 10	3,7
389748	25	23	6 to 10	3,7
400755	19	17	6 to 10	3,6
403391	27	24	6 to 10	3,5
405338	26	23	6 to 10	3,5
418331	28	24	6 to 10	3,4
420929	27	23	6 to 10	3,4
434056	23	19	6 to 10	3,3
436520	28	23	6 to 10	3,3
452928	24	19	6 to 10	3,2
471801	25	19	6 to 10	3,0
485124	23	17	6 to 10	2,9
490673	26	19	6 to 10	2,9
506216	24	17	6 to 10	2,8
509546	27	19	6 to 10	2,8
527307	25	17	6 to 10	2,7
528418	28	19	6 to 10	2,7
548399	26	17	6 to 10	2,6
549806	23	15	6 to 10	2,6
569491	27	17	6 to 10	2,5

NOTE: See ["General Planting Rate Information"](#) on page 5-1 and ["Field Check Seed Population"](#) on page 2-44" for additional information Always field check seed population to verify planting rates.

**VACUUM PLANTING RATES FOR SOYBEAN 120 CELL DISC
28 TOOTH CONTACT WHEEL DRIVE SPROCKET
APPROXIMATE SEEDS / HECTARE FOR 70 CM ROWS**

70 cm Rows	Transmission Sprockets Drive	Transmission Sprockets Driven	Recomm, Speed Range (km/h)	Average Seed Spacing (cm)
244479	15	28	6 to 10	5,8
253533	15	27	6 to 10	5,6
263284	15	26	6 to 10	5,4
273818	15	25	6 to 10	5,2
277075	17	28	6 to 10	5,2
285226	15	24	6 to 10	5,0
287337	17	27	6 to 10	5,0
297626	15	23	6 to 10	4,8
298390	17	26	6 to 10	4,8
309674	19	28	6 to 10	4,6
310325	17	25	6 to 10	4,6
321141	19	27	6 to 10	4,4
323256	17	24	6 to 10	4,4
333493	19	26	6 to 10	4,3
337310	17	23	6 to 10	4,2
346833	19	25	6 to 10	4,1
360285	15	19	6 to 10	4,0
361286	19	24	6 to 10	4,0
374867	23	28	6 to 10	3,8
376995	19	23	6 to 10	3,8
388752	23	27	6 to 10	3,7
391165	24	28	6 to 10	3,7
402670	15	17	6 to 10	3,5
405653	24	27	6 to 10	3,5
408322	17	19	6 to 10	3,5
419851	23	25	6 to 10	3,4
423764	26	28	6 to 10	3,4
437346	23	24	6 to 10	3,3
438107	24	25	6 to 10	3,3
440063	27	28	6 to 10	3,2
456361	23	23	6 to 10	3,1
473262	28	27	6 to 10	3,0
473913	27	26	6 to 10	3,0
476202	24	23	6 to 10	3,0
491464	28	26	6 to 10	2,9
492868	27	25	6 to 10	2,9
496045	25	23	6 to 10	2,9
510049	19	17	6 to 10	2,8
513406	27	24	6 to 10	2,8
515886	26	23	6 to 10	2,8
532421	28	24	6 to 10	2,7
535727	27	23	6 to 10	2,7
552437	23	19	6 to 10	2,6
555570	28	23	6 to 10	2,6
576455	24	19	6 to 10	2,5
600473	25	19	6 to 10	2,4
617428	23	17	6 to 10	2,3
624494	26	19	6 to 10	2,3
644273	24	17	6 to 10	2,2
648512	27	19	6 to 10	2,2
671119	25	17	6 to 10	2,1

NOTE: See "General Planting Rate Information" on page 5-1 and "Field Check Seed Population" on page 2-44" for additional information Always field check seed population to verify planting rates.

DRY INSECTICIDE APPLICATION RATES
APPROXIMATE POUNDS/ACRE AT 8 KM/H

Meter Setting	70 cm Rows
CLAY GRANULES	
10	5,0
11	5,6
12	6,3
13	7,1
14	7,9
15	8,8
16	9,9
17	11,0
18	11,7
19	13,5
20	14,6
21	16,0
22	16,9
23	17,7
24	19,4
25	21,5
26	23,7
27	24,8
28	26,2
29	28,6
30	30,5
SAND GRANULES	
5	3,0
6	5,0
7	5,5
8	6,5
9	8,0
10	9,2
11	10,5
12	11,5
13	13,0
14	14,5
15	16,0
16	18,0
17	20,0
18	22,4
19	25,0
20	26,5
21	28,4
22	30,5
23	33,0
24	35,4
25	38,0

NOTE: Chart represents average values and should be used only as a starting point. Granular chemical flows through meter opening at a nearly uniform rate regardless of roller speed. Your actual rate will vary depending on insecticide, planting speed, and plant population. Planting speed/ground speed has the greatest effect on application rate. Field check your actual rate with insecticide you are using at speed and population you will be planting. See ["Granular chemical field check" on page 2-46](#) for more information.

FERTILIZER APPLICATION RATE CHART

Model NGP-6055 Pumps With 18 Tooth Sprocket and Ground Drive (Planter equipped with two piston pumps)

Pump Setting	1	2	3	4	5	6	7	8	9	10
24 Row 70 cm (Litres per hectare)	41,1	86,0	127,2	170,2	213,2	256,2	299,2	342,2	385,2	426,4

Check tires for correct operating pressure.

Charts calculated based on a solution weighing ten pounds per gallon (1,2 kg/l).

NOTE: Fertilizer application rates can vary from weights calculated in above chart. Make field checks to be sure you are applying fertilizer at desired rate.

To check the exact number of litres your fertilizer attachment will actually deliver on a 70 cm row spacing:

1. Remove hose from one fertilizer opener and insert it into a collection container secured planter frame.
2. Engage fertilizer attachment and drive forward for 53 m.
3. Measure fluid ml caught in container and divide that amount by 4. Results is liters fertilizer delivered per hectare when planting in 70 cm (e.g. 20 ml= 2 l; 50 ml= 5 l; 100 ml= 10 l).
4. Rinse collection container and repeat test on other rows if necessary.

NOTE: Refer to piston pump manual provided with pump for additional information.

FERTILIZER RATES - CENTRIFUGAL PUMP

NOTE: Refer to the Fertilizer Rates table on this page to size orifice for approximately 40 psi pressure for even fertilizer distribution.

The following table can be used to determine which orifice plates can be used to achieve the desired gallons per acre application rate for fertilizer. Liters per hectare (l/ha) is calculated at 5 mph (8 km/h) with a 70 CM row width.

Speed (km/h)	Orifice Diameter								
	0.020"	0.025"	0.028"	0.032"	0.037"	0.041"	0.048"	0.055"	0.065"
6.4	31.8	43.0	56.1	73.0	94.5	110.4	161.8	200.2	272.2
7.2	29.0	38.4	49.6	66.4	85.1	99.2	144.1	178.7	241.3
8.0	26.2	34.6	44.9	59.9	76.7	91.7	130.0	160.9	217.0
8.9	23.4	31.8	41.2	54.3	70.2	84.2	117.9	145.9	197.4
9.7	21.5	29.0	37.4	50.5	64.5	76.7	108.5	133.8	180.5
10.5	19.6	27.1	34.6	45.8	58.9	71.1	100.1	123.5	166.5
11.3	18.7	25.3	31.8	43.0	55.2	65.5	93.5	115.1	155.3
12.1	16.8	23.4	29.9	40.2	51.4	61.7	88.9	106.6	144.1
12.9	15.9	21.5	28.1	37.4	47.7	58.0	83.3	100.1	135.6

NOTE: Operating pressure while operating in the field should be 30 - 40 psi. Orifice diameter is factory installed at 0.037".

This page intentionally left blank.

NOTICE

Disconnect all electronic monitor and control modules prior to making any repairs or modifications to the planter or mounted attachments. Failure to do so will result in permanent damage to sensitive electronic components and could void your warranty.

LUBRICATION

The following pages show locations of all lubrication points. Proper lubrication of moving parts helps ensure efficient operation of your Kinze planter and prolongs the life of friction producing parts.

Lubrication Symbols

Lubricate at frequency indicated with SAE multipurpose grease.



Lubricate at frequency indicated with high quality SAE 10 weight oil or spray lubricant.

WHEEL BEARINGS

All drive, transport, and marker hub wheel bearings should be repacked annually and checked for wear.

1. Raise wheel off ground.
2. Check for bearing endplay by moving wheel side to side.
3. Rotate wheel to check for bearing roughness. If bearings sound rough, remove hub and inspect bearings.

NOTE: To repack wheel hubs, follow procedure outlined for wheel bearing replacement in this section except bearings and bearing cups are reused.

GREASE FITTINGS



WARNING

Uncontrolled movement of equipment can cause loss of control and could result in death, serious injury, or damage to property and equipment. Install all safety lockup devices before transporting equipment.



Parts equipped with grease fittings should be lubricated at frequency indicated with an SAE multipurpose grease. Clean fitting thoroughly before using grease gun. Frequency of lubrication recommended is based on normal operating conditions. Severe or unusual conditions may require more frequent attention.

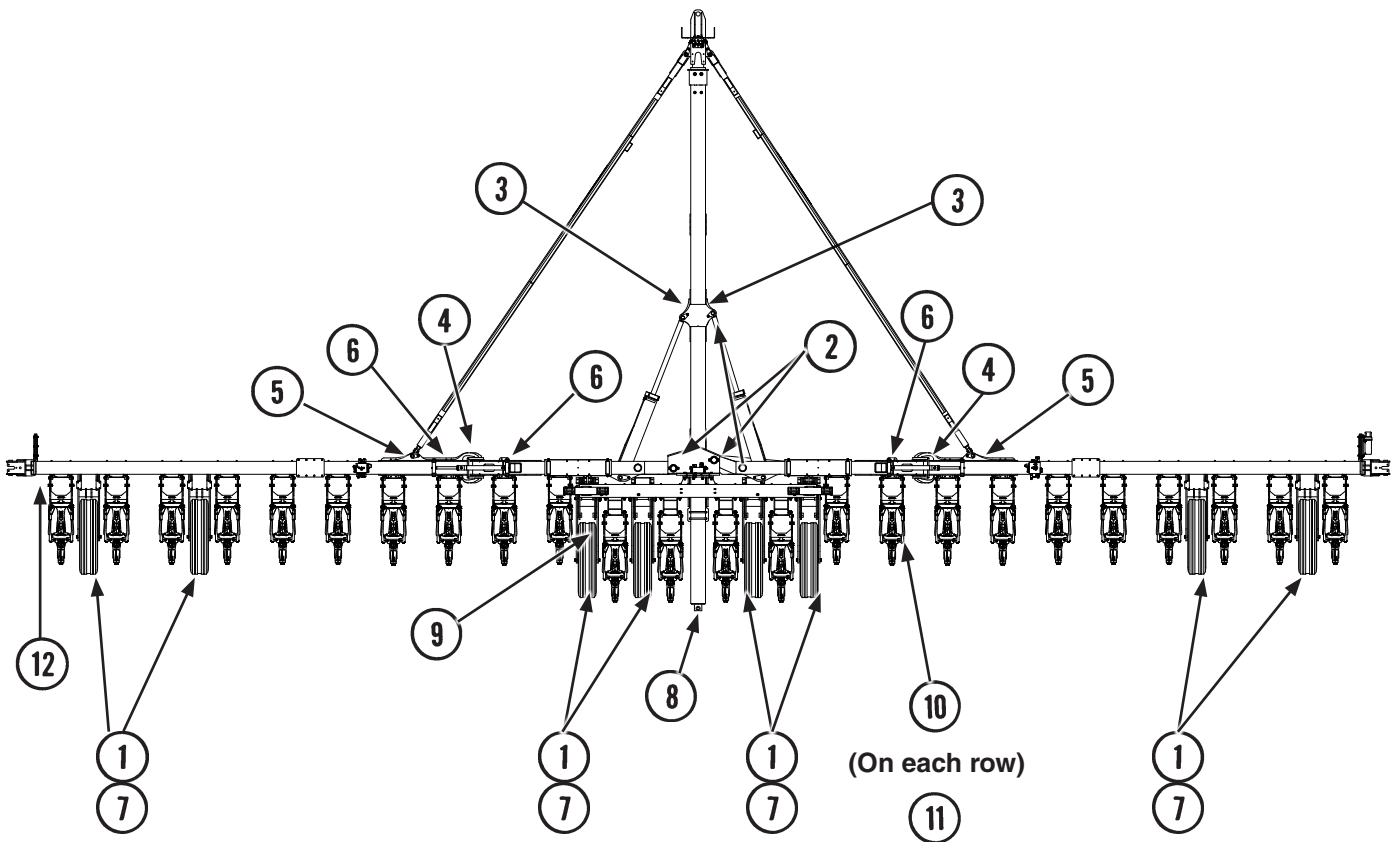

NOTE: Numbers on illustration above correspond to photos on following pages showing lubrication frequencies.

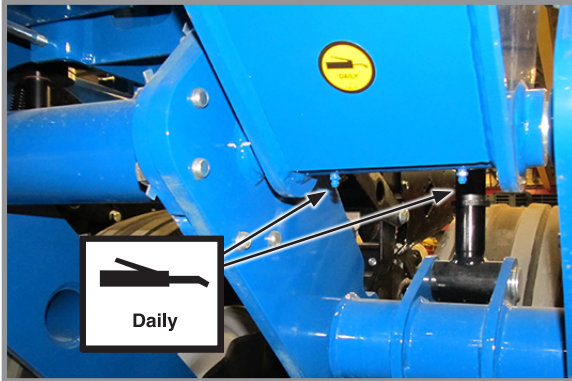

1. Wheel modules, 8 per machine
2 fittings per module



2. Fold pivot, 2 per machine
2 fittings per pivot

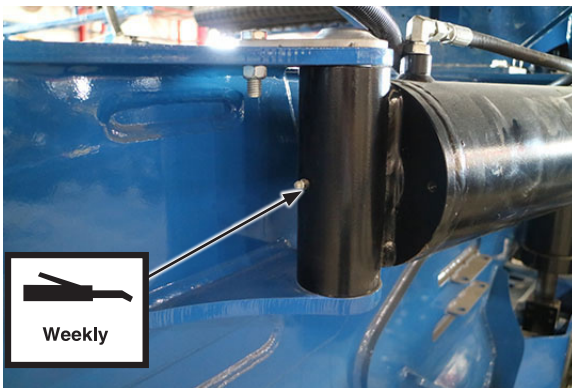

3. Fold cylinders, 2 per machine
2 fittings per cylinder (one each end)

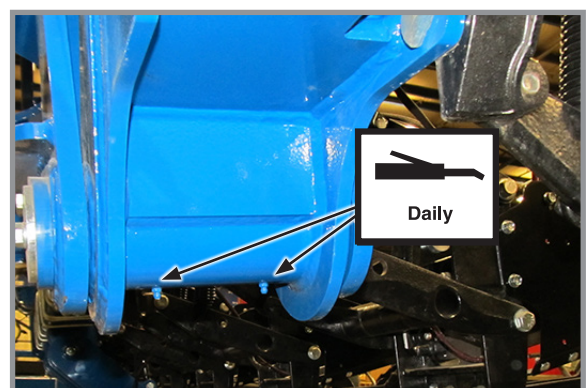

4. Wing pivot, 2 per machine
2 fittings per pivot



5. Draft Link, 2 per machine
1 fitting per link

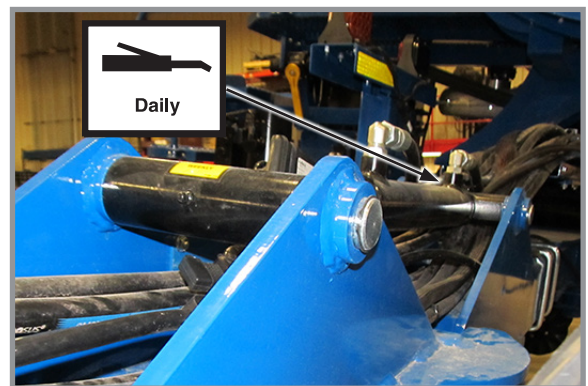

6. Wing Down Pressure Cylinder, 2 per machine
2 fittings per cylinder (one each end)

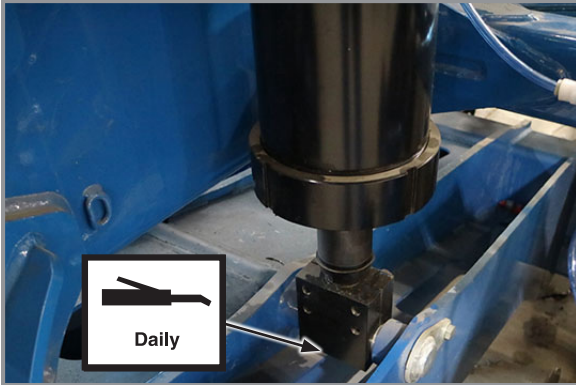

7. Lift Cylinder, 2 per machine
1 fitting per cylinder

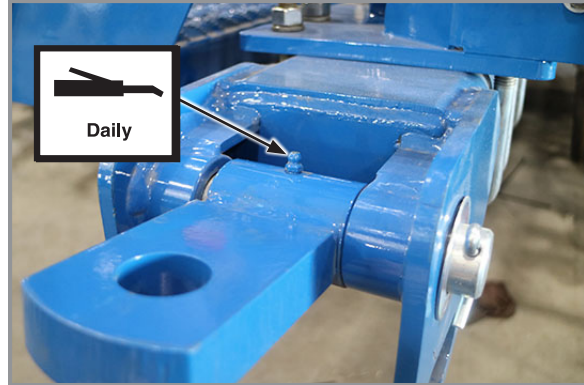

8. Trailer Hitch
1 fitting

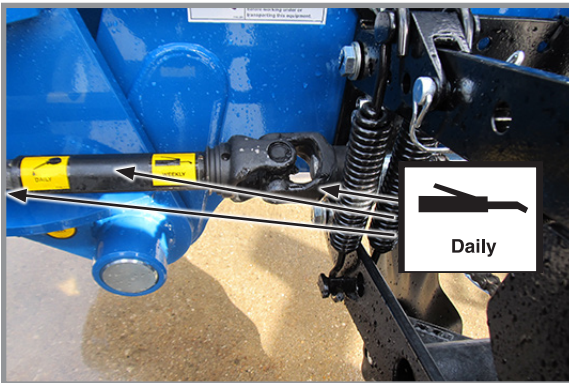

9. U-joint slide
3 fittings

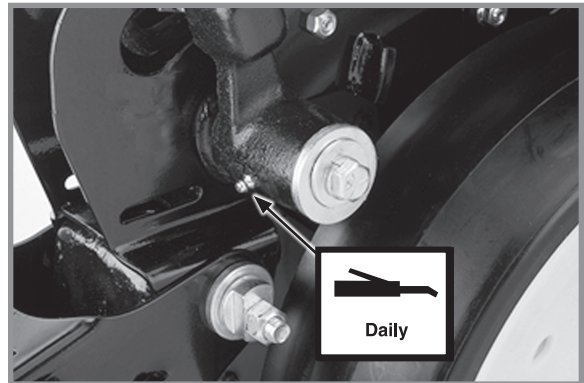

10. Gauge wheel arms - 1 per arm

(Seals in gauge wheel arm are installed with lip facing out to allow grease to purge dirt away from seal. Pump grease into arm until fresh grease appears between washers and arm.)

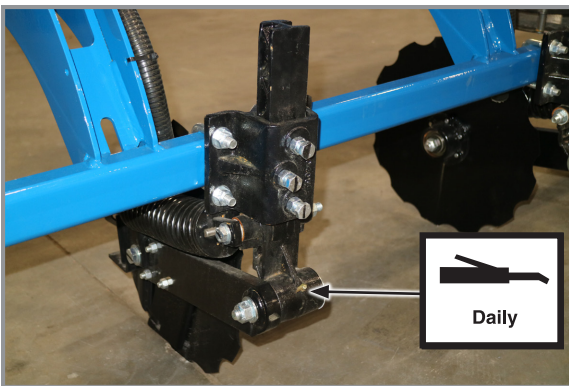

11. Fertilizer Opener

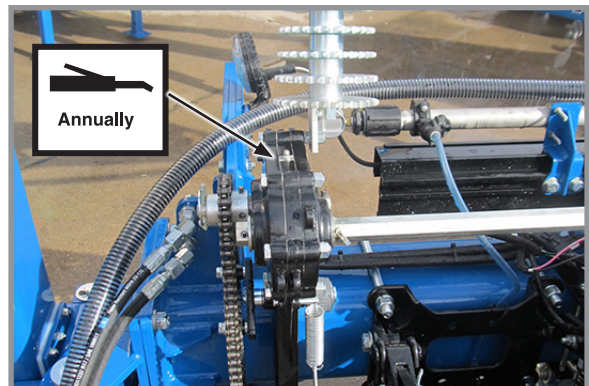

12. Transmission
1 fitting

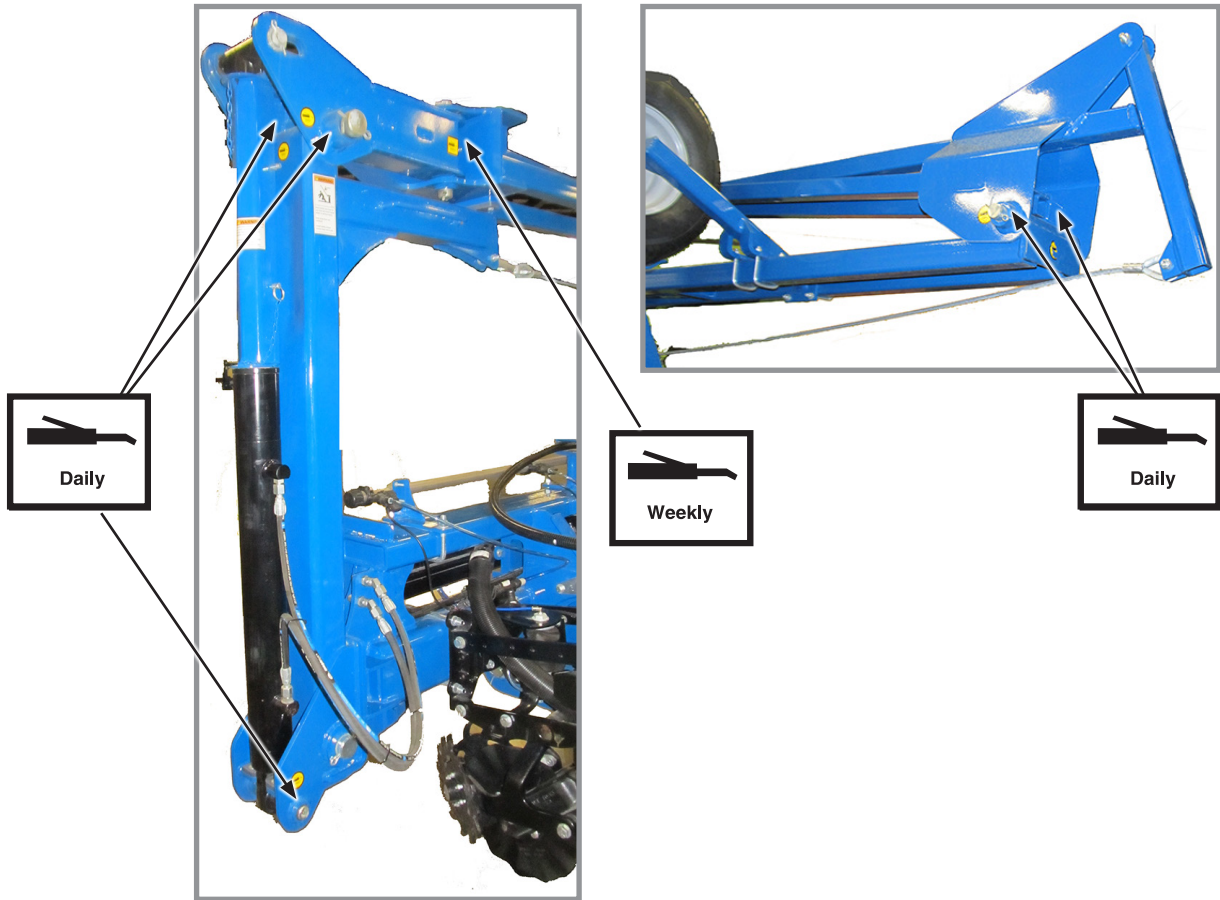

Row Markers

NOTCHED SINGLE DISC OPENER

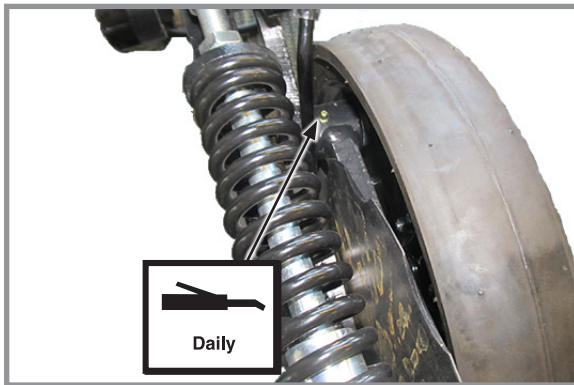

Grease to purge - 1 fitting

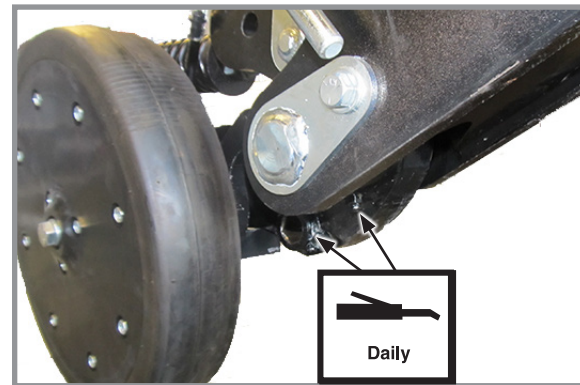

Grease to purge - 2 fittings

PTO SHAFT COUPLING

Clean and grease PTO shaft coupling each time pump is installed.

Apply coating of high-speed industrial coupling grease, such as Chevron® Coupling Grease meeting AGMA CG-1 and CG-2 Standards to extend shaft spline life.

MOUNTING BOLTS AND HARDWARE

Before operating planter for the first time, check all hardware is tight. Check all hardware again after first 50 hours of operation and beginning of each planting season.

All hardware used on the Kinze planter is Grade 5 (high strength) unless otherwise noted. Grade 5 cap screws are marked with three radial lines on the head. Hardware must be replaced with equal size, strength, and thread type.



WARNING



Loose transport wheel lug bolts can result in wheel separation from planter and result in death, serious injury, and damage to property and equipment. Check transport wheel lug nut torque before operating planter for the first time and periodically thereafter.



NOTICE

Over-tightening hardware can reduce its shock load capacity and cause equipment failure.

TORQUE VALUES CHART - PLATED HARDWARE

Diameter	Grade 2 (No marks) 		Grade 5 (3 marks) 		Grade 8 (6 marks) 	
	Coarse	Fine	Coarse	Fine	Coarse	Fine
1/4"	5.7 Nm	6.3 Nm	8.6 Nm	9.8 Nm	12 Nm	14 Nm
5/16"	11 Nm	12 Nm	18 Nm	19 Nm	24 Nm	27 Nm
3/8"	20 Nm	23 Nm	31 Nm	35 Nm	45 Nm	50 Nm
7/16"	34 Nm	37 Nm	50 Nm	56 Nm	71 Nm	79 Nm
1/2"	48 Nm	54 Nm	77 Nm	87 Nm	108 Nm	122 Nm
9/16"	68 Nm	81 Nm	108 Nm	122 Nm	156 Nm	176 Nm
5/8"	95 Nm	108 Nm	149 Nm	169 Nm	217 Nm	244 Nm
3/4"	176 Nm	197 Nm	271 Nm	298 Nm	380 Nm	427 Nm
7/8"	169 Nm	190 Nm	434 Nm	475 Nm	610 Nm	678 Nm
1"	258 Nm	278 Nm	651 Nm	719 Nm	915 Nm	1017 Nm
1 1/8"	359 Nm	407 Nm	814 Nm	908 Nm	1302 Nm	1458 Nm
1 1/4"	508 Nm	563 Nm	1139 Nm	1261 Nm	1844 Nm	2034 Nm
1 3/8"	664 Nm	759 Nm	1491 Nm	1695 Nm	2413 Nm	2752 Nm
1 1/2"	881 Nm	990 Nm	1966 Nm	2237 Nm	3128 Nm	3620 Nm

NOTE: Torque unplated hardware and bolts with lock nuts approximately 1/3 higher than above values. Torque bolts lubricated prior to installation to 70% of value shown in chart.

CYLINDER ROD PISTON RETAINING NUT TORQUE CHART

	Non-Nylock Nut	Nylock Nut
1/2"-20	55-70 ft-lb (~75-95 Nm)	45-55 ft-lb (~61-75 Nm)
3/4"-16	115-125 ft-lb (~156-169 Nm)	100-115 ft-lb (~136-156 Nm)
7/8"-14	150-180 ft-lb (~203-244 Nm)	130-150 ft-lb (~176-203 Nm)
1"-14	275-330 ft-lb (~373-447 Nm)	250-275 ft-lb (~339-373 Nm)
1 1/8"-12	300-375 ft-lb (~407-508 Nm)	275-300 ft-lb (~373-407 Nm)
1 1/4"-12	300-375 ft-lb (~407-508 Nm)	275-300 ft-lb (~373-407 Nm)

TORQUE VALUES- ALUMINUM

Diameter	Torque Value
1/8"	15-18 ft-lb (~20-24 Nm)
3/8"	29-32 ft-lb (~39-43 Nm)
1/2"	29-33 ft-lb (~39-45 Nm)
3/4"	29-33 ft-lb (~39-45 Nm)

NOTE: Use these torque values with pneumatic down pressure components.

SPECIAL TORQUE VALUES & INSTRUCTIONS

Row unit parallel linkage bushing hardware	130 ft-lb (~176 Nm)
5/8" No till coultter spindle hardware	120 ft-lb (~162 Nm)
Row Unit Disc Opener Blade Bolt**	110 ft-lb (~149 Nm) **Left hand side is left hand thread.
Row Unit Support (Face Plate)	90 ft-lb (~122 Nm)
Notched Single Disc Opener - 3/4" L-bolts	160 ft-lb (~217 Nm)
Notched Single Disc Opener - 5/8" Hex Head Cap Screws	90 ft-lb (~122 Nm)
Notched Single Disc Opener - 3/4" Hex Set Screws	160 ft-lb (~217 Nm)

TORQUE VALUES - TRUE DEPTH HYDRAULIC DOWN FORCE

Cylinder Head to Body:	95 Nm
Cylinder Piston to Rod:	68 Nm
Row Unit Valve Cartridge to Line Body:	41 Nm
Row Unit Valve Solenoid to Valve:	7 Nm

NOTE:

1. A 6-Pt Socket must be used to torque the cylinder head to the body.
2. Apply blue threadlocker to cylinder head threads when reassembling.
3. Replace piston to rod locknut with equivalent 7/16-20 locknut before reassembling.

TORQUE VALUES - WHEEL LUG NUTS

Wheel Nut Size	Torque Value	Interval
5/8" - 18 Wheel Lug Nuts and Lug Bolts	200 ft-lb (270 Nm)	<ul style="list-style-type: none"> • Once before first planting; • Again after first 50 km or 10 operational hours; • Periodically thereafter (at least once before every planting season).
9/16" - 18 Wheel Lug Nuts and Lug Bolts	125 ft-lb (170 Nm)	<ul style="list-style-type: none"> • Once before first planting; • Again after first 50 km or 10 operational hours; • Periodically thereafter (at least once before every planting season).

NOTICE	Wipe hose ends to remove any dirt before connecting couplers to tractor ports or contamination may cause equipment failure.
---------------	--

Hydraulic Fitting Installation

The following info is to help you identify and properly install some of our standard hydraulic fittings.

SAE (JIC) 37° Flare

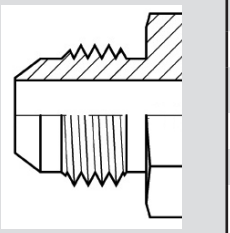
	Dash	Thread Size	Torque - ft-lb (Nm)
	-4	7/16-20	9-12 ft-lb (~12-16 Nm)
	-6	9/16-18	14-20 ft-lb (~19-27 Nm)
	-8	3/4-16	27-39 ft-lb (~37-53 Nm)
	-10	7/8-14	37-63 ft-lb (~50-85 Nm)
	-12	1 1/16-12	66-88 ft-lb (~90-119 Nm)

ORFS (O-Ring Face Seal)

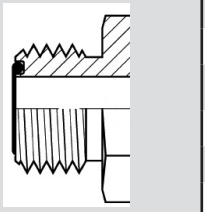
	Dash	Thread Size	Torque - ft-lb (Nm)
	-4	9/16-18	18 ft-lb (~25 Nm)
	-6	1 1/16-16	30 ft-lb (~40 Nm)
	-8	1 3/16-16	41 ft-lb (~55 Nm)
	-10	1-14	59 ft-lb (~80 Nm)
	-12	1 3/16-12	85 ft-lb (~115 Nm)

ORB (O-Ring Boss)

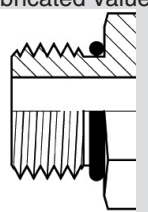
	(Lubricated Values)	Dash	Thread Size	Torque Non-Adjustable ft-lb (Nm)	Torque Adjustable ft-lb (Nm)
		-4	7/16-20	30 ft-lb (~40 Nm)	15 ft-lb (~20 Nm)
		-6	9/16-18	34 ft-lb (~46 Nm)	34 ft-lb (~46 Nm)
		-8	3/4-16	59 ft-lb (~80 Nm)	59 ft-lb (~80 Nm)
		-10	7/8-14	100 ft-lb (~135 Nm)	100 ft-lb (~135 Nm)
		-12	1 1/16-12	136 ft-lb (~185 Nm)	185 ft-lb (~185 Nm)

FERTILIZER MAINTENANCE

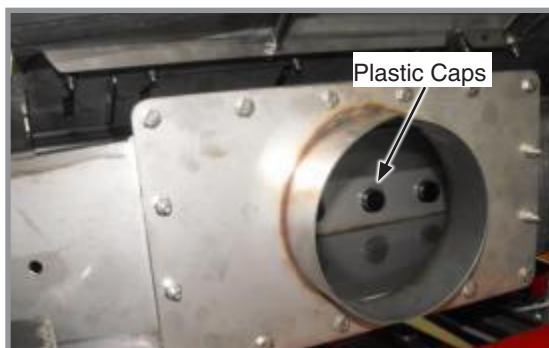

CLEANING THE SYSTEM

- Clean the hopper thoroughly. Abnormally dusty planting conditions may require more frequent cleaning.
- Do not leave deposits of fertilizer in the bottom of the distribution system or on the frame of the applicator.
- Open the stainless steel air box to aid in cleaning. **Do not remove the plastic caps (shown above).**
- Keep the flutes of the metering roller clean of residue during use. The accumulation of fertilizer on the flues will reduce the amount of fertilizer applied to the field.

END OF SEASON STORAGE

- Clean the applicator to remove residual fertilizer, dirt and debris that can hold moisture and cause rust.
- Confirm Bulk Fill and dry fertilizer hoses were not crushed during fold/unfold operation.
- Check for missing, damaged or worn parts and consult your dealer for replacement.
- Clean the frame to remove fertilizer dust that has accumulated during the planting season to prevent equipment from rusting prematurely.

FERTILIZER MAINTENANCE (CONTINUED)

LUBRICANTS AND CAPACITIES

APPLICATION	LUBRICANT	CAPACITY	INTERVAL
Variable Transmission	Clear Trans-Hydraulic Oil	1,75 l	Once per season. Check level daily.
Oil Reservoir	Dexron III Oil	8 l	Once per season. Check level daily.

- Grease 2 fittings on fan drive system every 100 hours.
- Grease 2 fittings on distribution drive system every 100 hours.

OTHER MAINTENANCE

OTHER MAINTENANCE OR VERIFICATION	INTERVAL
Check chains tension	Daily
Inspect rubber on fans	Daily
Check water accumulation in fan and empty	Daily

VACUUM SEED METER MAINTENANCE

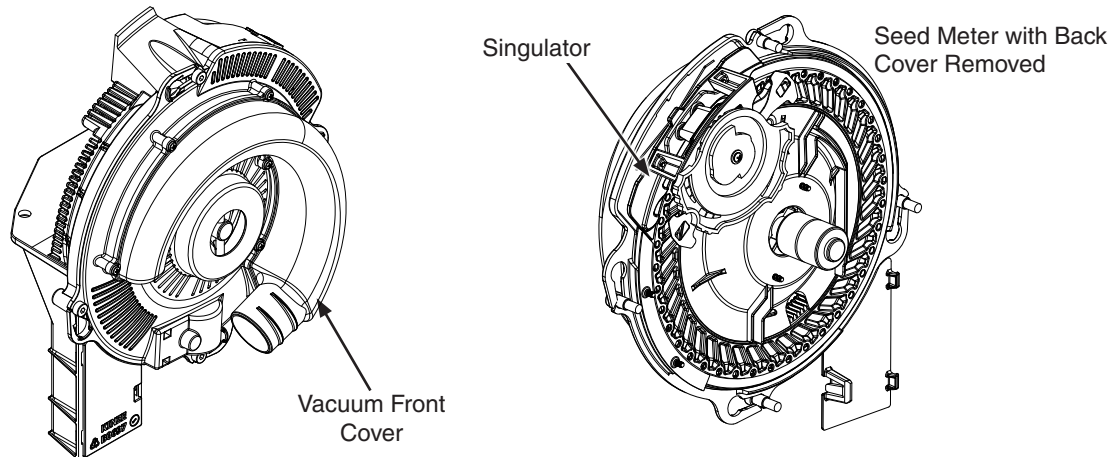

Before each planting season inspect seed discs and singulator and clean or replace as needed.

Use clean, high quality seed for maximum meter accuracy. Damaged or cracked seed, hulls, and foreign material may become lodged in seed disc orifices and greatly reduce meter accuracy.

Inspect and clean seed discs daily checking for any buildup of foreign material and blocked orifices. If seed disc orifices are plugged frequently with seed remnants, clean out brush with ball-type ejector (if applicable) may need to be replaced. Clean seed disc by washing it with soap and water. Dry thoroughly.

Inspect singulator blades and guide for wear after every 80 ha per row of operation. If adjustment of singulator blade does not affect meter performance or if blades appear worn, singulator blade may need to be replaced.

Replace seed disc or vacuum seal if abnormally high vacuum is required or if consistent operation cannot be achieved. See [“Preparation for Storage” on page 6-27](#) for additional Vacuum Seed Metering System maintenance.

NOTE: Remove seed discs from meters for annual storage and store them vertically on a dowel or pipe.

SEED METER CLEANOUT

NOTE: Use of damaged seed or seed containing foreign material will cause plugging of seed cell orifices and require more frequent seed meter cleanout to prevent underplanting.

Thorough seed meter cleanout is important to maintain genetic purity.

1. Disengage seed drive and remove seed hopper and meter.
2. Dump seed from right rear corner of hopper into a container.
3. Lay hopper on its right side. Push release button and rotate seed meter vacuum cover clockwise to align keyhole slots with bolt heads. Lift off cover.
4. Rotate seed disc hub clockwise to unlock and remove seed disc.
5. Empty meter.
6. Thoroughly inspect meter to ensure all seed is removed.
7. Replace seed disc. Install vacuum cover.

VACUUM MANIFOLD MAINTENANCE

Dust accumulates in manifolds and hoses during normal operation. Clean manifolds annually. Abnormally dusty planting conditions may require more frequent cleaning.

1. Remove vacuum hose from each seed meter.
2. Operate vacuum fan at full hydraulic flow from tractor for two minutes to clear manifolds, hoses, and fittings of dust and debris.
3. Shut down fan and replace hoses

GAUGE WHEEL ADJUSTMENT

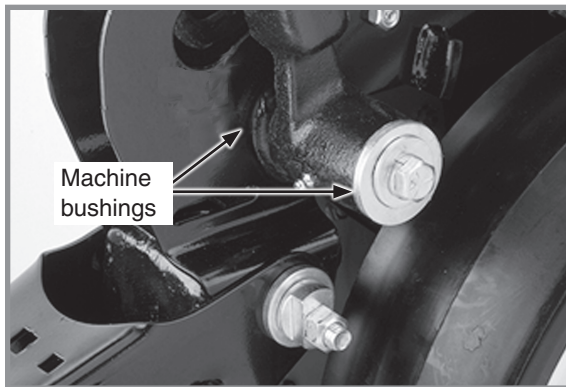

NOTE: It may be desirable to space gauge wheel further from blade when operating in sticky soils.

NOTE: Set depth adjustment handle at 3x2 position and lift gauge wheel to stop one side at a time.

Gauge wheels should lightly contact opener blades to prevent accumulation of dirt or trash. Gauge wheels and opener blades should turn with only slight resistance.

Add or remove machine bushings between shank and gauge wheel arm to adjust clearance between gauge wheels and opener blades. Store remaining machine bushings between gauge wheel arm and flat washer on outer side of gauge wheel arm.

Contact should be no less than one half of the rotation of the wheel, while not sticking in any position (it does not have to be continuous) Wheel should rotate in the direction of travel of the row unit. Wheel can be held in position by supporting the spindle bolt head.

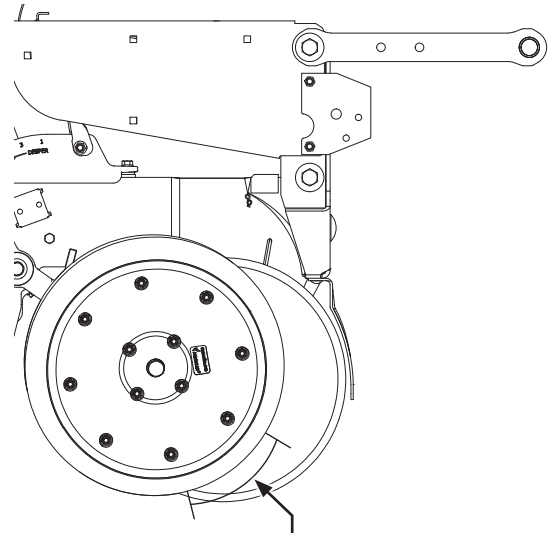

Shim gauge wheel to lightly contact opener disc blade in this area for 4" to 6" (10-15 cm). Check adjustment in operating position.

GAUGE WHEEL ARM BUSHING/SEAL REPLACEMENT

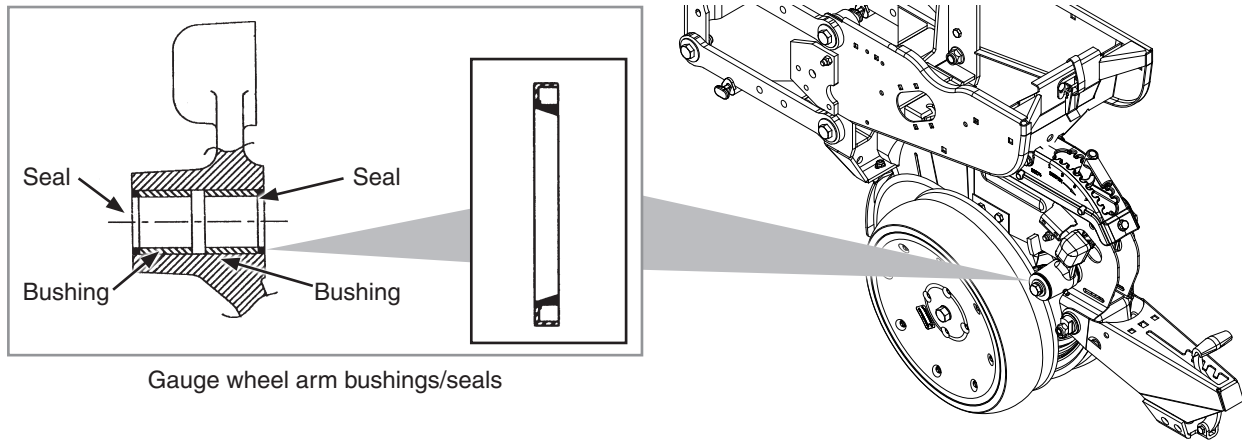

NOTE: Gauge Wheel Arm Bushing and Seal Driver Kit (G1K296) is available through your Kinze Dealer.

1. Remove gauge wheel from arm.
2. Remove gauge wheel arm from shank assembly.
3. Remove seal and bushing and discard. Clean and dry inner bore.
4. Drive/press replacement bushing inside bore of arm to a depth of .125" below flush.
5. Coat wiping edge of seal with grease.
6. Drive/press seal into place with lip to outside.

NOTE: Use extra care to protect the sealing lip during installation. Apply uniform pressure to assemble the seal into the bore of the arm. Never apply a direct hammer blow to the seal surface.

7. Inspect gauge wheel pivot spindle.
8. Reinstall gauge wheel arm assembly and gauge wheel.

NOTE: Use special machine bushing between gauge wheel arm and gauge wheel.

9. Shim for proper gauge wheel tire/disc blade clearance.
10. Lubricate with an SAE multipurpose grease.

15" SEED OPENER DISC BLADE/BEARING ASSEMBLY

NOTICE

Excessive blade contact may result in premature disc opener bearing/hub failures and excessive wear on seed tube guard/inner scraper. When properly adjusted, if one blade is held in fixed position, opposite blade should rotate with less than 5 pounds force (~22 N) at outer edge of blade.

Maintain approximately $1" \pm \frac{1}{2}"$ (~2,5 ± 1 cm) of blade-to-blade contact to properly open and form seed trench. As blade diameter decreases due to wear, it is necessary to relocate machine bushings from inside to outside to maintain $1" \pm \frac{1}{2}"$ (~2,5 ± 1 cm) of contact.

NOTE: Proper blade clearance is critical. Blades should have $1" \pm \frac{1}{2}"$ (~2,5 ± 1 cm) contact in this area. When blades are turned by hand in opposite directions against each other, there should be only light resistance to turning. Re-adjust blade scraper if necessary to center it between the blades.

NOTE: Replace blades if proper blade-to-blade contact cannot be maintained after relocating machine bushings or if blade diameter wears below $14\frac{1}{2}"$ (~37 cm).

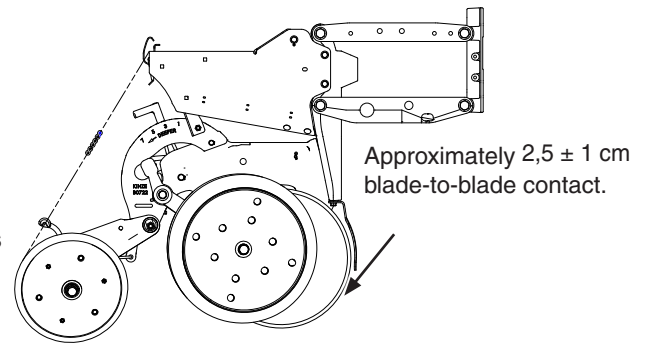

REPLACE DISC BLADE/BEARING ASSEMBLY

NOTE: Only bearing may need to be replaced if there is excessive endplay or if bearing sounds or feels rough when disc blade is rotated.

1. Remove gauge wheel, scraper, and bearing dust cap.
2. Remove cap screw, washer and disc blade/bearing assembly. Machine bushings between shank and disc blade are used to maintain approximate $1" \pm \frac{1}{2}"$ (~2,5 ± 1 cm) of blade-to-blade contact.

NOTICE

Left hand side of opener uses a left hand threaded cap screw. **DO NOT OVER TIGHTEN.** Damage to shank threads require replacement of row unit shank assembly.

3. Install machine bushing(s), new disc blade bearing assembly, washer and cap screw. Torque $\frac{5}{8}"$ -11 Grade 5 cap screw to 110 ft-lb (~149 Nm).

NOTE: Replace disc blades only with disc blades of equal thickness.

4. Install bearing dust cap, scraper, and gauge wheel.

15" SEED OPENER DISC BLADE/BEARING ASSEMBLY (CONTINUED)

REPLACE BEARING ONLY

1. Remove gauge wheel, scraper, bearing cap, cap screw, washer and disc blade/bearing assembly.
2. Remove ¼" rivets from bearing housing to expose bearing.
3. Installing new bearing. Install three evenly spaced ¼" cap screws into three of six holes in bearing housing to hold bearing and bearing housing in place. Install rivets in other three holes. Remove ¼" cap screws and install rivets in those three holes.
4. Reinstall disc blade/bearing assembly, washer and cap screw. Torque ⅝"-11 cap screw to 110 ft-lb (~149 Nm.)
5. Install bearing dust cap, scraper, and gauge wheel.

SEED TUBE GUARD/INNER SCRAPER

Seed tube guard protects seed tube and acts as inner scraper for seed opener disc blades.

Remove seed tube and check for wear. Excessive wear on seed tube indicates a worn seed tube guard. Replace seed tube guard if it measures ⅝" (~1,6 cm) or less at lower end. A new seed tube guard measures approximately ⅞" (~2,2 cm).

NOTE: No till planting or planting in hard ground conditions, especially when planter is not equipped with no till coulters, and/or excessive blade-to-blade contact increases seed tube guard wear and requires more frequent inspection and/or replacement.

Remove gauge wheel and disc blade from one side of row unit. Lift up inner scraper approximately 90° to remove from slot when replacement is necessary.

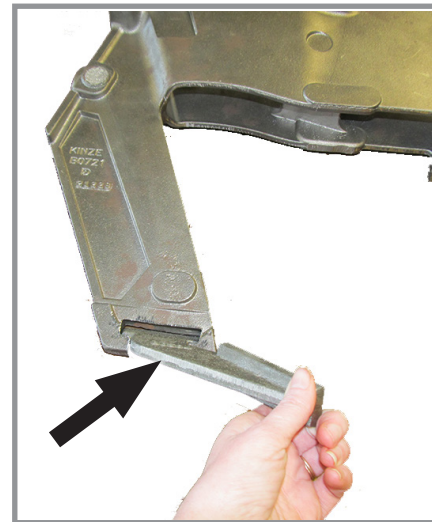

**Seed Tube Guard/Inner Scraper
(Gauge wheel/seed opener disc blade removed
for easier identification of scraper)**

ROW UNIT MOUNTED NO TILL COULTER

Check nuts and hardware periodically for proper torque.

NOTE: Torque $\frac{5}{8}$ " spindle hardware to 120 ft-lb (162 Nm).

Be sure coulters are positioned square with row unit and aligned in front of row unit disc opener.

Coulters can be adjusted to one of four settings. Initially the blade is set in the highest position. As the blade wears, it can be adjusted to one of three lower settings. See "Row Unit Mounted No Till Coulters" in the Row Unit Operation section of this manual.

Replace 16" (~41 cm) diameter coulters when worn to 14½" (~37 cm).

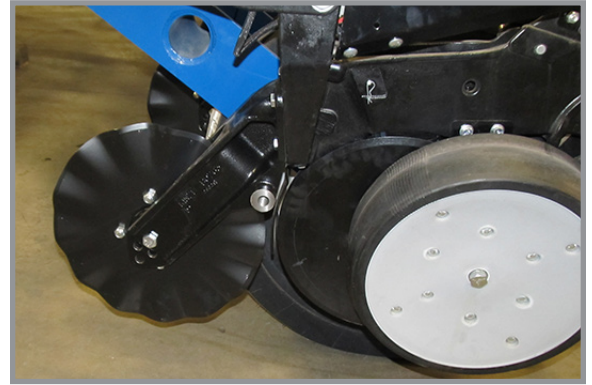

Row Unit Mounted No Till Coulters

COULTER OR ROW UNIT MOUNTED RESIDUE WHEELS



Coulters Mounted Residue Wheel

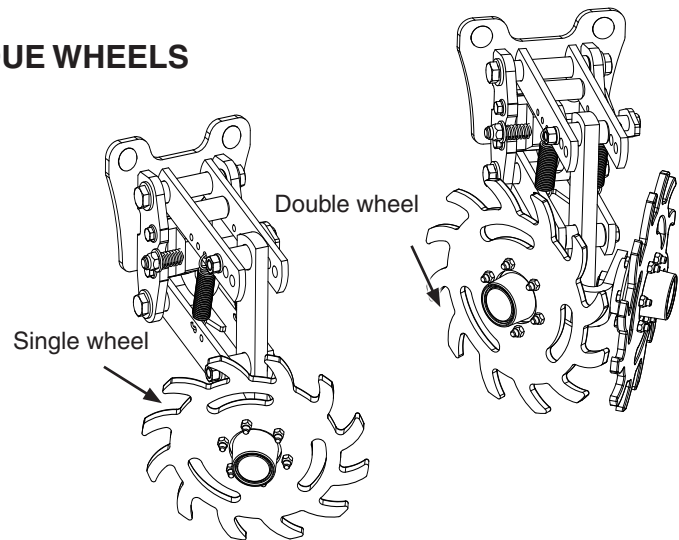

Row Unit Mounted Residue Wheel

Wheel hubs are equipped with sealed bearings. If a bearing sounds or feels rough when the wheel is rotated, replace them.

SPIKED CLOSING WHEEL

Inner parts of the spiked closing wheel will begin to wear at approximately 70% of life. Flip/reverse the wheel to utilize the remaining life of the wheel.

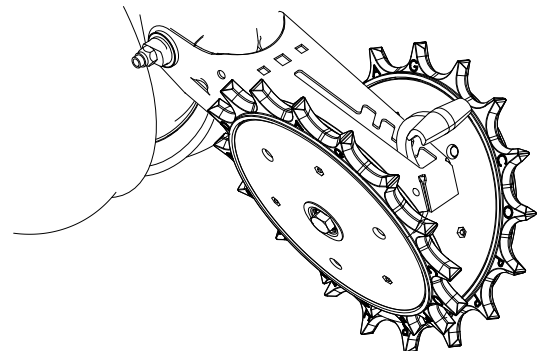

Row Unit Spiked Closing Wheel

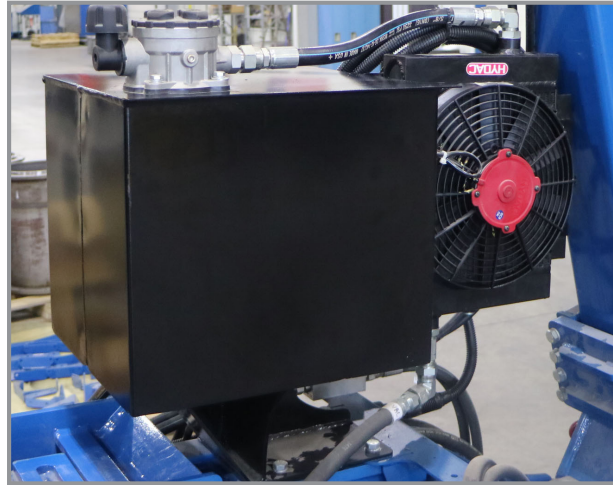
TRACTOR MOUNTED PUMP DRIVE AND OIL COOLER**NOTICE**

Clean and grease PTO shaft coupling with high-pressure industrial coupling grease (Chevron® coupling grease or equivalent) meeting AGMA CG-1 and CG-2 Standards each time driveshaft is installed or premature wear and equipment failure can occur.

NOTE: Periodically check and clean oil coolers.

1. Replace 10-micron spin-on filters on tank annually.
2. Fill system with multigrade wide temperature range transmission hydraulic fluid. Reservoir capacity is approximately 8 gallons (30 l). See ["OIL specification" on page 2-7](#) for more information.
3. Start system and run with tractor at idle and fans turned off for 1-2 minutes. Switch fans to full speed and run with tractor at idle for 1-2 minutes.
4. Check reservoir fluid level and fill as required. Hydraulic fluid level should be within 1"-2" (~2,5 cm - 5 cm) from top of reservoir after pump has run and hydraulic hoses have been primed to allow fluid to expand when heated.

CHECK VALVE

A check valve is located in each vacuum fan motor block assembly and operates as a return line check to prevent vacuum fan motor reverse operation. Remove and inspect valve. If it does not operate properly. Check for foreign material and if O-ring is leaking internally. Replace if defective.

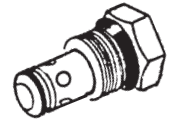

FLOW CONTROL VALVES

Two flow control valves are located in valve block on right wing of planter. Flow control valves should be adjusted for row marker raise and lower speed as part of assembly procedure or upon initial operation. If valve fails to function properly or requires frequent adjustment, it should be removed for inspection. Check for foreign material and contamination on valve and seating areas of valve body. Replace defective components.

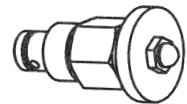

PRESSURE RELIEF VALVES

Pressure relief valve in valve block on left wing of planter functions during lowering out of raised transport sequence. Valve is factory set and should require no additional adjustment. Pressure relief valve located in valve block on tongue functions during tongue extend cycle. This pressure relief valve ensures latch cylinder extends and releases prior to tongue extending. Valve is factory set and should require no additional adjustment. Contact your Kinze Dealer for service.

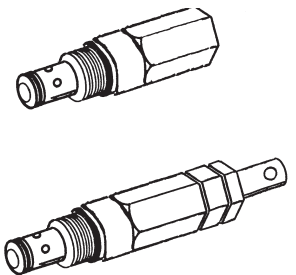

NOTICE

Connect hydraulic motor case drain to a case drain return line with zero pressure on tractor or hydraulic motor will be damaged. DO NOT connect hydraulic motor case drain to SCV outlet. Contact tractor manufacturer for specific details on “zero pressure return”.

PRESSURE COMPENSATED FLOW CONTROL VALVES

There are three pressure compensated flow control valves used on the planter. One is located on the vacuum fan block, on the Bulk Fill fan block and on the power pack block.

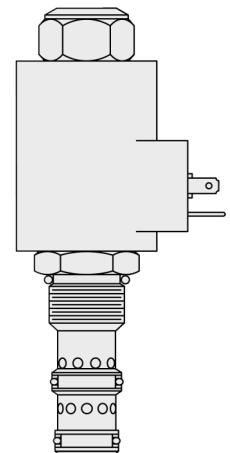

SOLENOID VALVE

Solenoid valve consists of a chambered body with an electric coil actuated cartridge valve.

If solenoid or solenoids fail to operate, first determine if problem is electrical or hydraulic. If valve is working properly, a click will be heard when solenoid coil is energized and valve stem opens. If no sound is heard, check solenoid coil by touching top of coil housing with a metallic object such as a pliers or screwdriver. If coil is working properly, coil housing will be strongly magnetized when energized. If voltage to coil is low it will be weakly magnetized when energized and no click will be heard.

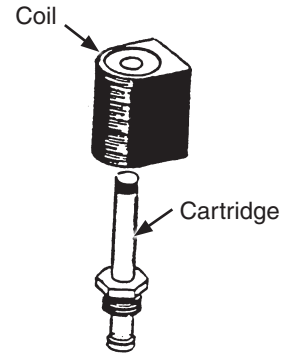

PWM FLOW CONTROL VALVE

PWM flow control valve is used to control the fans on the Blue Drive equipped planters. The Blue Vantage System controls the valve so no operator adjustment is required.

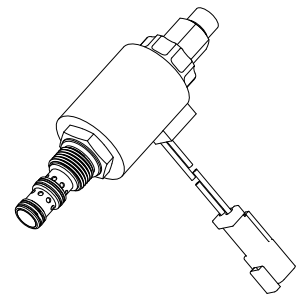

HYDRAULIC DOWN FORCE PROPORTIONAL PRESSURE REDUCING/RELIEVING VALVE (TRUE DEPTH OPTION)

Proportional pressure relief valves are located on each row of planters equipped with the True Depth hydraulic down force system. *These valves are factory set and should require no additional adjustment.* Each valve acts independently and controls the fluid pressure on the cap end of the down force cylinder. Consult your Kinze Dealer for service.

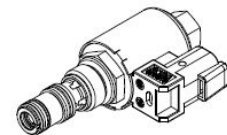

PNEUMATIC DOWN PRESSURE AIR COMPRESSOR TANK

Moisture should be drained daily from the tank. Tank should be drained completely for storage.

To drain tank, locate drain plug on the bottom of tank. Stand off to the side of tank and pull cable attached to drain.

NOTE: If moisture is not drained from tank rust particles will form inside tank.

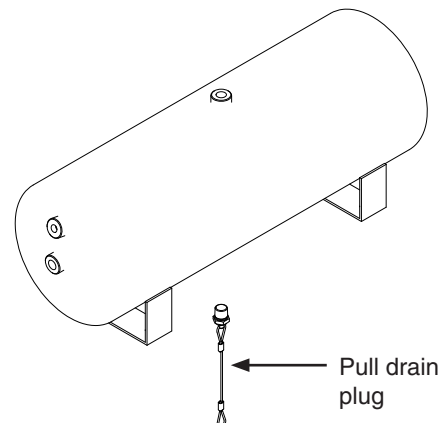

TRUE DEPTH HYDRAULIC SYSTEM SERVICING

True Depth Pressure Gauge

**WARNING**

Remove all hydraulic power sources and verify True Depth pressure gauge reads zero before servicing.

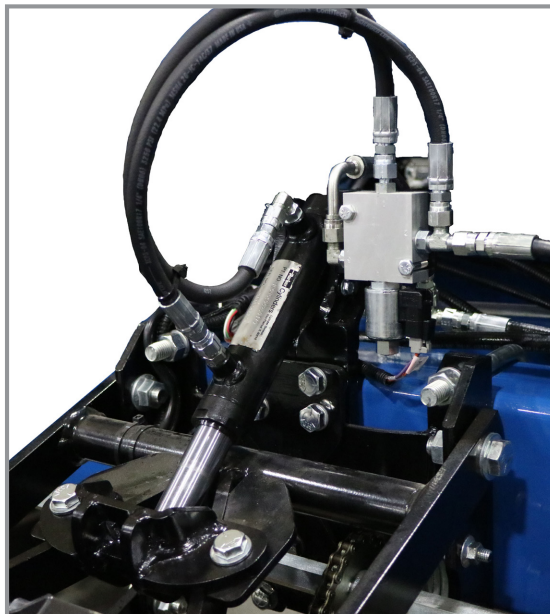

True Depth Cylinder

**WARNING**

Flow out of the rod end port of the cylinder must not be restricted when pressurizing cap end port as 4.5:1 pressure intensification will occur on the rod end of the cylinder potentially resulting in failure of the cylinder and loss of containment of the piston rod assembly.



True Depth Filter

TRUE DEPTH FILTER

Replace filter cartridge annually, every 100 hours of operation, or when the clogging indicators point out the limit pressure drop created inside the filter.

To replace the cartridge:

1. Stop the system in "Machine Stopped" status
2. Secure any shut-off valves on the hydraulic circuit.
3. Unscrew the filter container (1).
4. Remove the clogged filtering cartridge (5), making sure no residual particles have settled in the bowl bottom.
5. Make sure the O-ring (2-4) and the anti-extrusion ring (3) are not damaged, otherwise replace them and consequently position the new ones correctly.
6. Insert the new filtering cartridge, lubricating the sealing O-ring beforehand.
7. Screw the container tight (1) making sure the threading is screwed correctly. Tighten to a tightening torque of 65 Nm.
8. Start the machine for a few minutes.
9. Make sure there are no leaks.

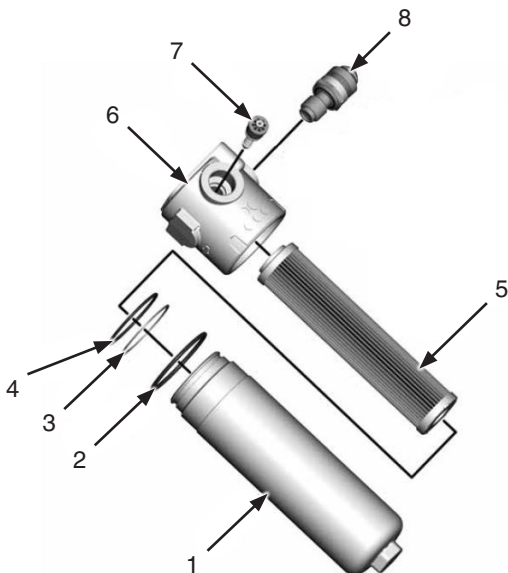

1. Filter Bowl
2. External O-Ring
3. Anti-extrusion ring
4. Sealing O-Ring
5. Filtering Element
6. Filter Head
7. By-pass valve
8. Visual differential indicator

True Depth Cylinder

ROW MARKER BEARING LUBRICATION OR REPLACEMENT

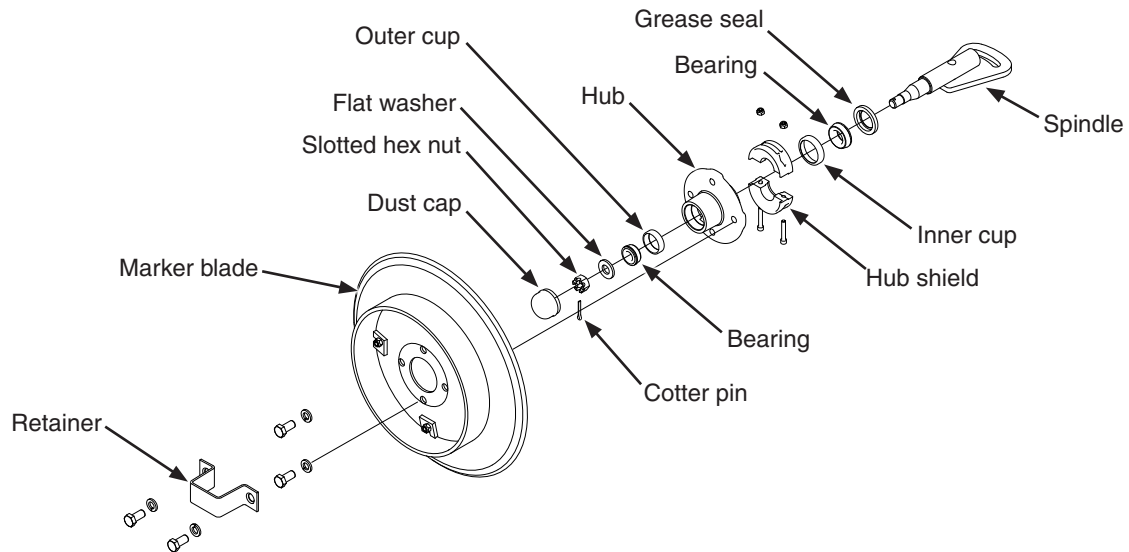

1. Remove retainer and marker blade.
2. Remove dust cap from hub.
3. Remove hub shield. Note direction of installation.
4. Remove cotter pin, slotted hex nut, and washer.
5. Slide hub from spindle.
6. Remove bearings and cups and discard if bearings are being replaced. Clean hub and dry. Remove bearings only and not cups if repacking.
7. Press in new bearing cups with thickest edge facing in. (Bearing replacement procedure only.)
8. Pack bearings with heavy duty wheel bearing grease thoroughly forcing grease between roller cone and bearing cage. Fill the space between the bearing cups in the hub with grease.
9. Install rubber seal into grease seal. Place inner bearing in place and press in new rubber seal/grease seal.
10. Clean spindle and install hub.
11. Install outer bearing, washer and slotted hex nut. Tighten slotted hex nut while rotating hub until there is some drag. This ensures all bearing surfaces are in contact. Back off slotted nut to nearest locking slot and install cotter pin.
12. Fill dust caps approximately $\frac{3}{4}$ full of wheel bearing grease and install on hub.
13. Install hub shield.
14. Install marker blade and retainer on hub. Tighten hardware evenly.

!
WARNING

Uncontrolled movement of equipment can cause loss of control and could result in death, serious injury, or damage to property and equipment. Install all safety lockup devices before transporting equipment.



TRANSPORT AND LIFT/GROUND DRIVE WHEEL BEARING REPACK OR REPLACEMENT

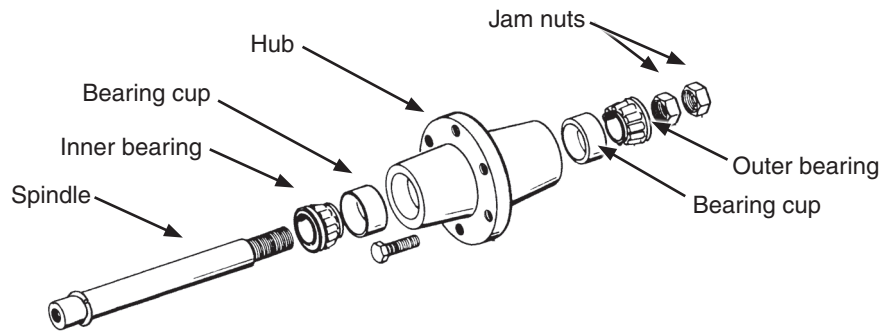

1. Raise tire clear of ground and remove wheel.
2. Remove double jam nuts and slide hub from spindle.
3. Remove bearings and cups and discard if bearings are being replaced. Clean hub and dry. Remove bearings only and not cups if repacking.
4. Press in new bearing cups with thickest edge facing in. (Bearing replacement procedure only.)
5. Pack bearings with heavy duty wheel bearing grease thoroughly forcing grease between roller cone and bearing cage. Fill space between bearing cups and hub with grease.
6. Place inner bearing in place.
7. Clean spindle and install hub.
8. Install outer bearing and jam nut. Tighten jam nut while rotating hub until there is some drag. This ensures all bearing surfaces are in contact. Back off jam nut $\frac{1}{4}$ turn or until there is only slight drag when rotating hub. Install second jam nut to lock against first.
9. Install wheel on hub. Tighten hardware evenly. Refer to the torque chart information included previously in this section.

FERTILIZER CHECK VALVE CLEANING AND REPAIR

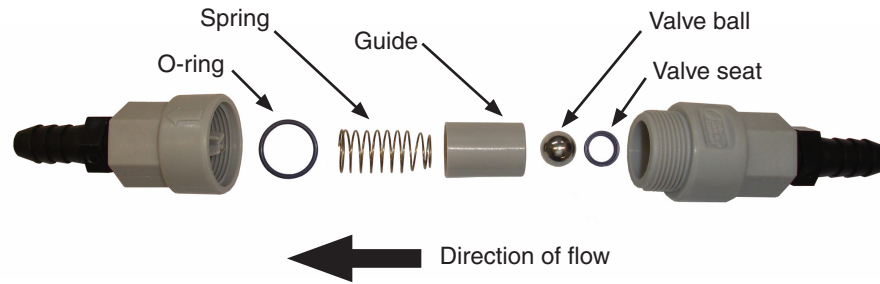

1. Unscrew valve body and separate halves. Note direction and location of parts.
2. Clean and inspect parts. Flush with clean water. Replace damaged parts.
3. Reassemble exactly as shown. O-ring and valve seat must be firmly in place inside each half of valve body.

LIQUID FERTILIZER PISTON PUMP CRANKCASE OIL LEVEL

Check crankcase oil daily and maintain at oil level check plug. Fill as needed with EP 90 weight gear oil. Total oil capacity is approximately $\frac{3}{4}$ pint.

Refer to operator and instruction manual supplied with pump and flow divider for more information.

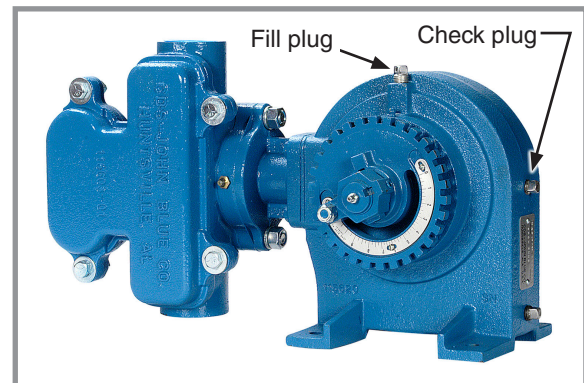

Piston Pump Oil Fill and Check Plug Locations

PISTON PUMP MAINTENANCE

- Check oil daily and fill crankcase to proper level with a quality grade SAE 90 weight gear oil. With the pumpsitting level, the oil should be within $\frac{1}{2}$ " of the bottom of the hole on back of crankcase. You may use along wire or zip tie as a dipstick to check the level – some length is required due to the hole's depth.
- Lubricate all grease zerks on roller chain sprocket spacer, outboard cover plate, crankshaft end, and at stuffing box flange daily. Fill zerks until grease is visibly seen seeping from mating parts. For the stuffing box flange zerk, grease will be seen seeping from the vent on the opposite side of the flange.
- Pump oil should be changed seasonally or more often in extreme use conditions.
- Visually inspect sprocket and drive chain daily for excessive wear or corrosion. Lubricate chain regularly to reduce corrosion. Chain alignment must be straight.

PISTON PUMP STORAGE

NOTICE

Keep air out of the pump! This is the only way to prevent corrosion. Even for short periods of storage, the entrance of air into the pump causes **RAPID and SEVERE CORROSION**. Freezing temperatures can cause the fluid or water to freeze internally to the pump, which can cause severe damage to the wet-end castings.

OVERNIGHT

Suspension fertilizer must be flushed from the pump for ANY storage period. For Clear Liquids:

1. Steady or rising temperatures: leave pump and hoses filled with solution. DO NOT DRAIN nor admit air to the pumps.
2. Cooling weather: (solution likely to salt out), fill pump with water and leave filled. DO NOT admit air.
3. Freezing temperature: fill pump with RV-antifreeze and leave filled, DO NOT admit air.

ONE TO TWO WEEKS

ACCEPTABLE: Flush pump thoroughly with 5 to 10 gallons of a solution that will neutralize the liquid last pumped (refer to that manufacturer's instructions). Fill with clean water and DO NOT DRAIN. Keep pump sealed to exclude air. If freezing temperatures are remotely possible, the winter storage procedure (see below) must be used to avoid damage to the pump castings.

PREFERRED: Flush pump as detailed above. IMMEDIATELY fill all passages in pump with straight RV antifreeze which contains a rust inhibitor. Place 1-1/2" NPT PVC plugs in the suction and discharge fittings to keep pump full and exclude air.

WINTER STORAGE

1. Flush pump as detailed above.
2. With pump set on 10, draw in straight RV-antifreeze until the discharge is clean. If system utilizes a flow divider (FD), pump the RV-antifreeze through the FD manifold until it is seen in the discharge lines. Fill pump and plug suction and discharge fittings of pump to retain RV-antifreeze.

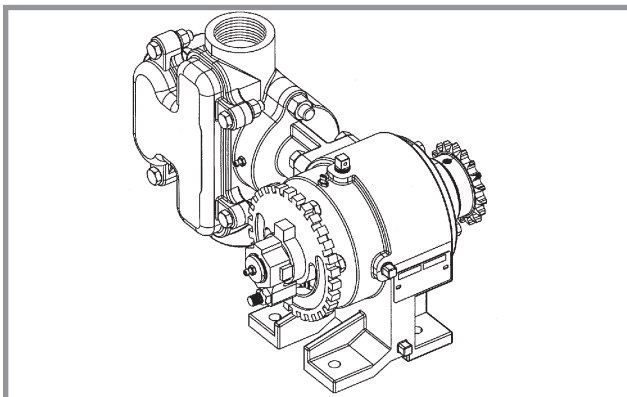

Liquid fertilizer piston pump

PREPARATION FOR STORAGE

Store planter in a dry sheltered area if possible.

Remove all trash wrapped on sprockets or shafts and remove dirt that can draw and hold moisture.

Clean all drive chains and coat with a rust preventative spray, or remove chains and submerge in oil.

Lubricate planter and row units at all lubrication points (see [“Lubrication” on page 6-1](#) for more details).

Inspect planter for parts that in need of replacement and order during “off” season.

Make sure all seed and granular chemical hoppers are empty and clean.

Remove seed discs from seed meters, clean and store meters in a rodent-free, dry area with discs removed. Store seed discs vertically on a dowel or pipe.

Remove vacuum hose from each seed meter. Operate vacuum fan at full hydraulic flow from tractor for two minutes to clear manifolds, hoses and fittings of dust and debris.

Clean breather on analog vacuum and pressure gauges.

Disassemble, clean and grease all U-joint slides.

Grease or paint disc openers/blades and row marker disc blades to prevent rust.

Flush liquid fertilizer tanks, hoses and metering pump with clean water. See [“Piston pump” on page 4-3](#) “Piston Pump Storage” if applicable.

Bulk Fill System:

- Clean out bulk fill hopper, entrainment assembly, and delivery hoses.
- Disconnect delivery hoses from entrainer ports. Install small orange caps onto ports. Attach hoses to caps.
- Disconnect delivery hoses from air dissipator at each row unit. Install large orange caps. Attach hoses to caps.
- Check all bolts and fasteners used to assemble and attach entrainment device are tight (if applicable).
- Loosen knobs on entrainer cleanout doors to remove pressure from door gaskets.
- Inspect all seed delivery hoses and replace any that are worn, cut, or cracked.

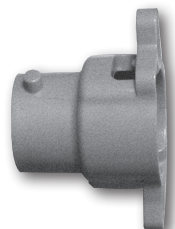

Entrainer Cap

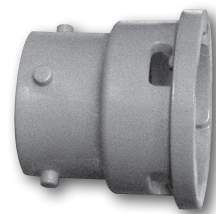

Air Dissipator Cap

TIRE PRESSURE



WARNING

Explosive separation of rim and tire parts can cause death or serious injury. Overinflation, rim and tire servicing, improper use of rims and tires, or worn or improperly maintained tires could result in a tire explosion.



- Maintain proper tire pressure. Inflating a tire above or below the recommended pressure can cause tire damage. See [“Tire Specifications” on page 1-6](#) for more information.
- Mount tires only by properly trained personnel using proper equipment.
- Replace tires with cuts or bubbles. Replace damaged rims. Replace missing lug bolts and nuts.
- Do not weld or heat wheel assembly. Heating increases tire pressure.

INFLATION SPECIFICATIONS

Row Marker
(Not Shown)

Contact Drive
(N/A with
Blue Vantage
System)

Wing



Transport

Tire Locations (R.H. shown)

See [“Tire Specifications” on page 1-6](#) for additional information.

HYDRAULIC HOSE LIFE

 WARNING	Pressurized hydraulic fluid can penetrate body tissue and result in death, serious infection, or other injuries. Fluid injected under skin must be IMMEDIATELY removed by a surgeon familiar with this type of injury. Make sure connections are tight and hoses and fittings are not damaged before applying system pressure. Leaks can be invisible. Keep away from suspected leaks. Relieve pressure before searching for leaks or performing any system maintenance.
--	---

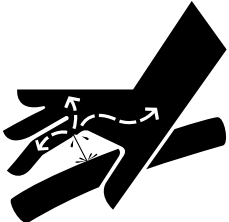

Proper storage of hydraulic hoses can significantly increase the life of the hoses, for a period of three to five years. After this period, service life of hoses may decrease, depending on variables such as variances in rubber materials and storage environment. Refer to the guidelines below for best practices when storing.

- Store in a clean, cool and dry area
- Avoid direct sunlight or moisture
- Do not store near high power electrical equipment
- Avoid contact with corrosive chemicals
- Avoid ultraviolet light
- Avoid areas with obvious signs of insects or rodents

Unusually long periods of storage or poor storage environment may lead to performance issues or premature failure. Always inspect all hoses prior to use for extensive wear, cuts, or holes. If such flaws are identified, replace immediately to avoid potential failure, property damage or bodily injury.

LIFT/FOLD/WING DOWNFORCE HYDRAULIC SCHEMATIC

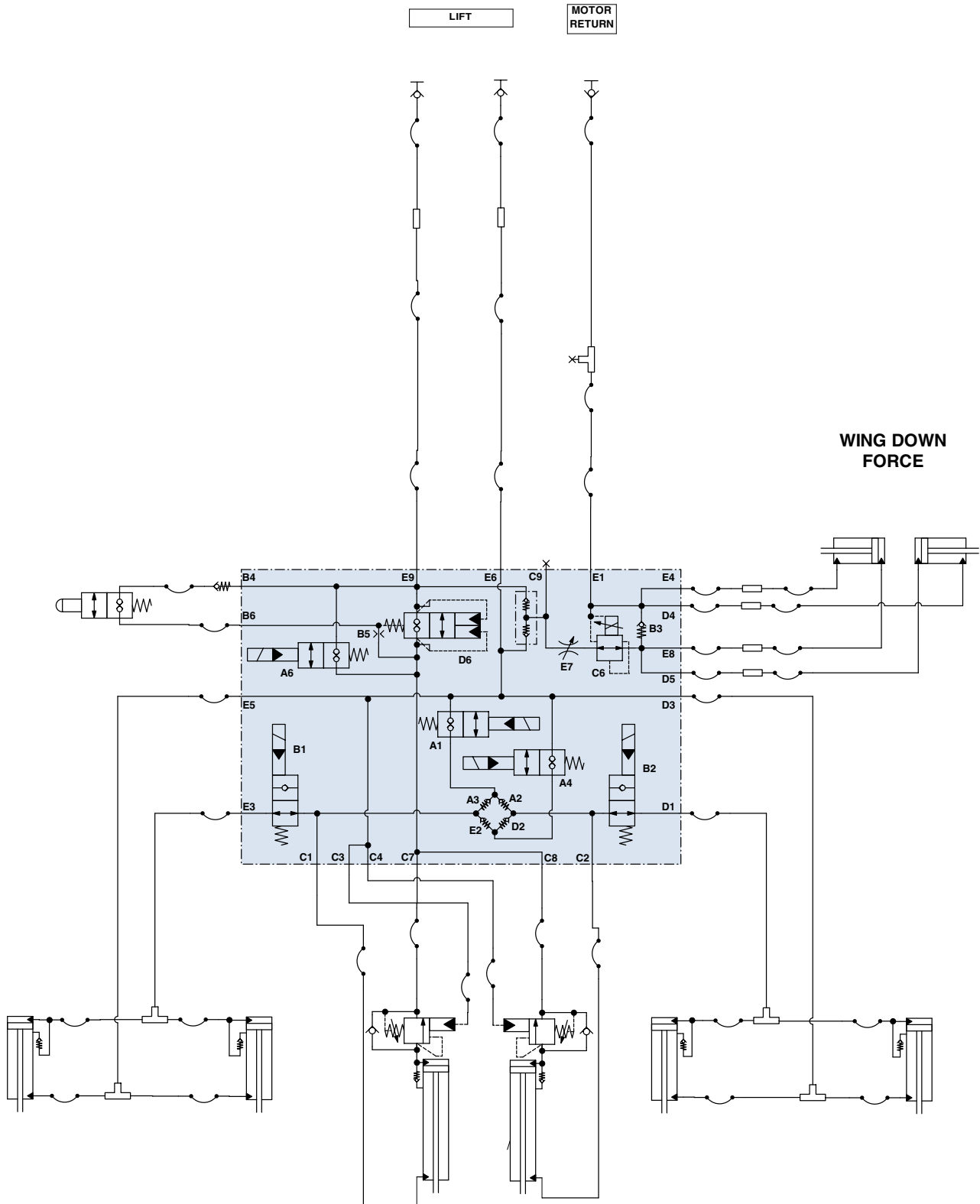

LIFT/WING DOWN
FORCE

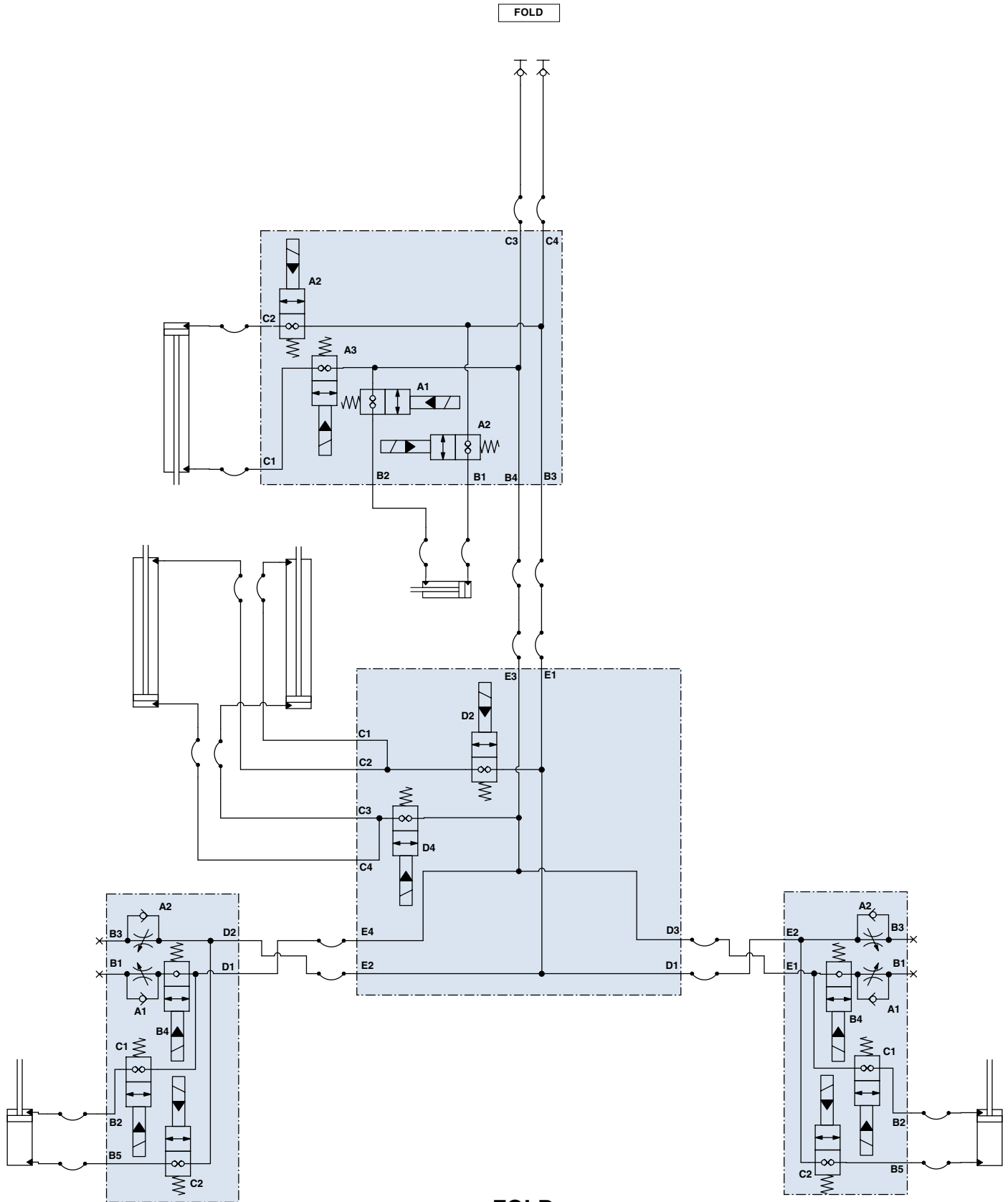

FOLD

FOLD

VACUUM AND BULK DRY FERTILIZER SYSTEM HYDRAULIC SCHEMATIC

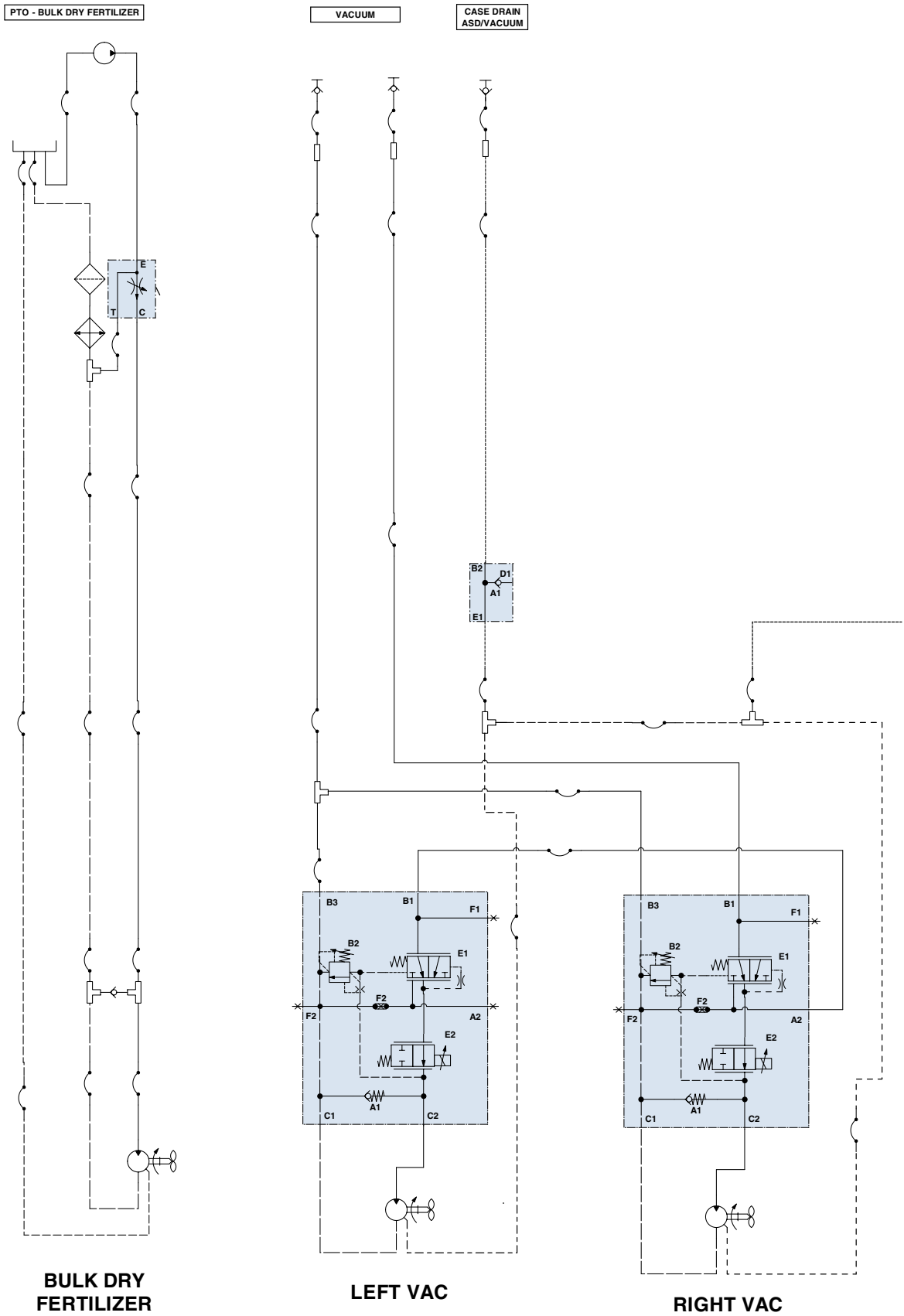

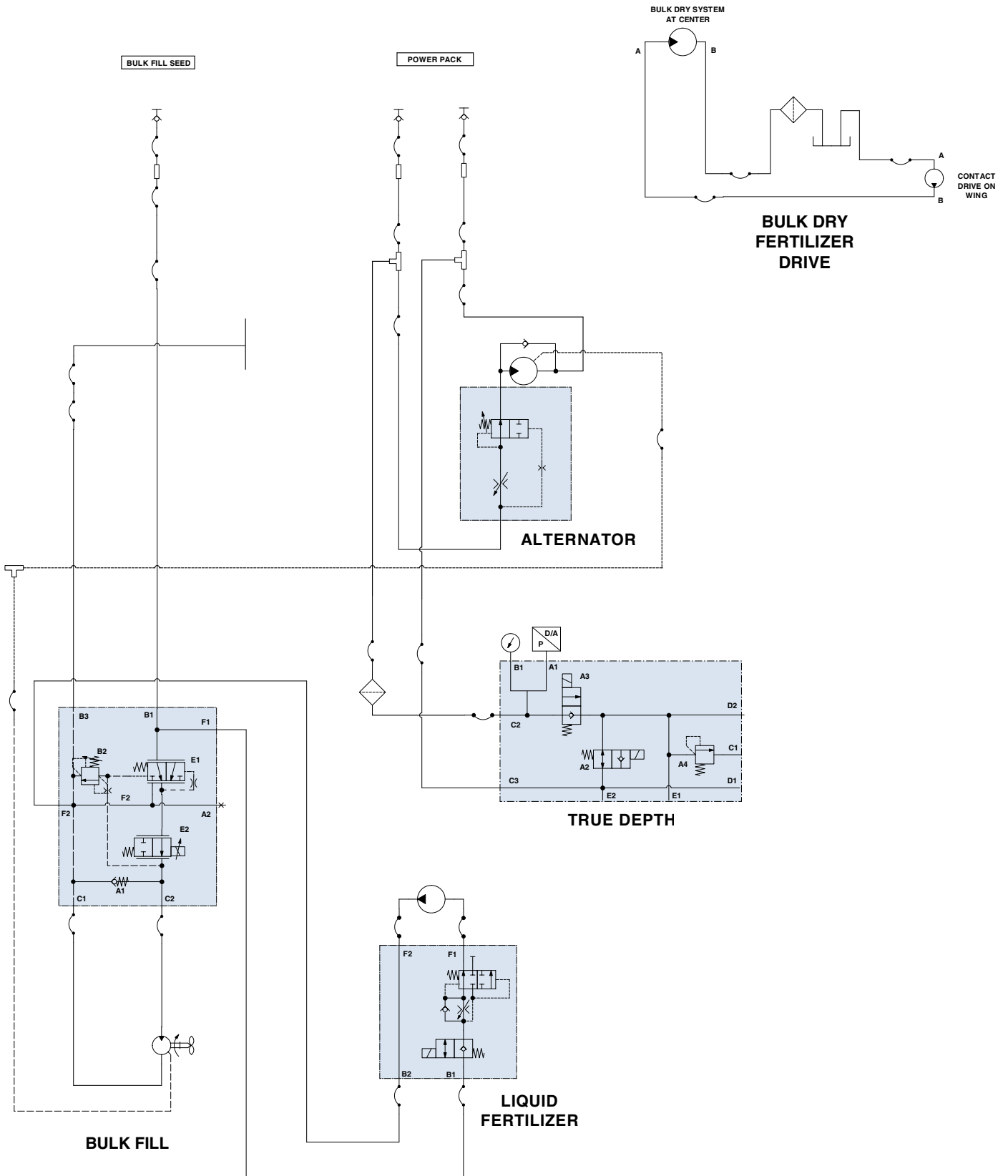

POWER PACK WIRING DIAGRAM (BLUE DRIVE)

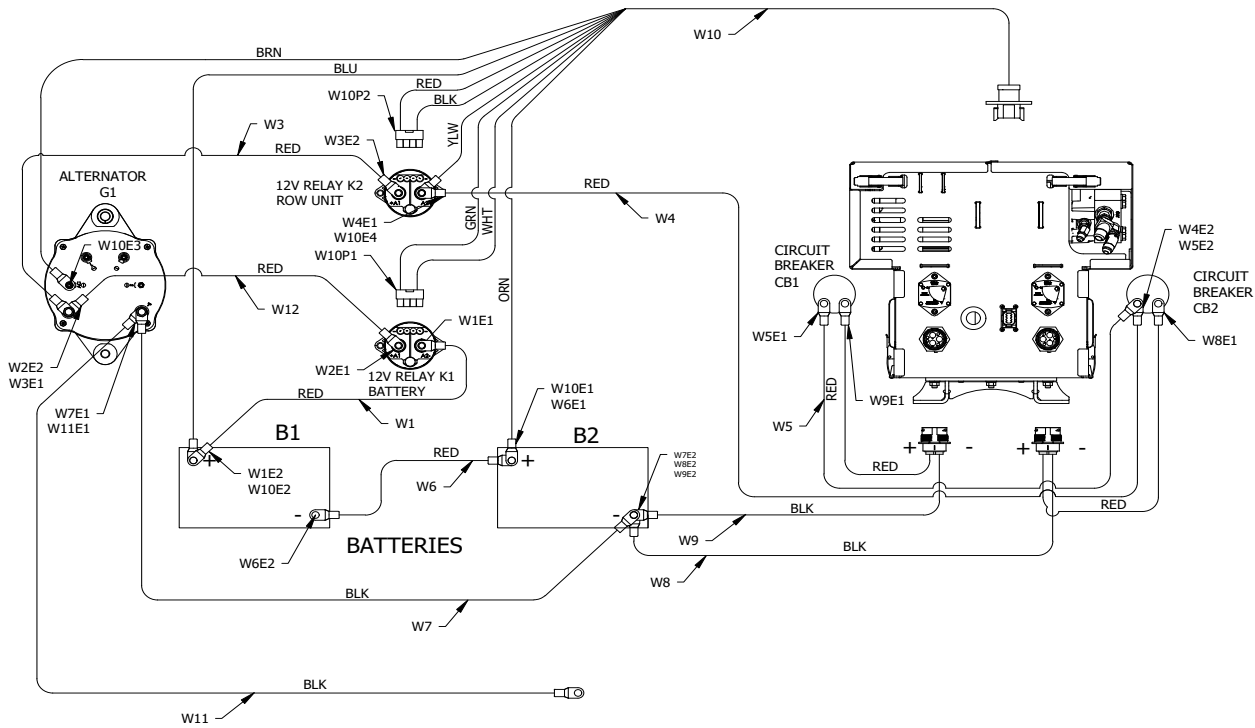

Component Hookup Chart, P/N 10112901

Reference Designator	From	Used with Item	To	Used with Item	Color	Function
W1	B1+	E2	K1A2-	E1	Red	Power
W12	K1A1+	E1	GB1+	E2	Red	Power
W3	GB1+	E1	K2A1+	E2	Red	Power
W4	K2A2-	E1	CB2, Line	E2	Red	Power
W5	CB1, Line	E1	CB2, Line	E2	Red	Power
W6	B2+	E1	B1-	E2	Red	Power
W7	B2-	E2	GB2-	E1	Black	Ground
W8	Pan	J1	CB2, Load	E1	Red	Power
			B2-	E2	Black	Ground
W9	Pan	J1	CB1, Load	E1	Red	Power
			B2-	E2	Black	Ground
W10	Pan	J1	K2	P2	Red/Black	RU Power Relay (Power & Ground)
			AC	E3	Brown	Alternator Sensor Frequency
			K2A2-	E4	Yellow	RU Power Feedback
			K1	P1	Green/White	Battery Pack Relay (Power & Ground)
			B1+	E2	Blue	Battery #1 Voltage Monitor
			B2+	E1	Orange	Battery #2 Voltage Monitor
W11	GB2-	E1	NC	E2	Black	Planter Ground

BATTERY CARE

NOTICE

Read and follow all manufacturer labels and instructions.

Battery Specifications	
Chemistry:	Wet lead acid (low maintenance)
Voltage:	12.00 V
Capacity:	>7.00 Ah
Weight:	15.3 lbs (6.9 kg)
Length:	194 mm
Width:	126 mm
Height:	183 mm
Termination:	Top post L Terminal

BEFORE PLANTING SEASON

- Check and clean all connections.
- Fully charge batteries before installing into the planter.
- Batteries more than two years old should be load checked.
- Reinstall batteries or connect the negative ground cables.

PREPARATION FOR STORAGE

Planter batteries that are stored for more than one month should be cared for as follows:

- Remove the batteries or disconnect the negative ground cable.
- Fully charge batteries before storing.
- Store in a cool and dry location.
- Keep from freezing.

NOTICE

When replacing batteries, replace both at the same time. NEVER replace one battery at a time. Batteries in Power Pack must be identical to one another.

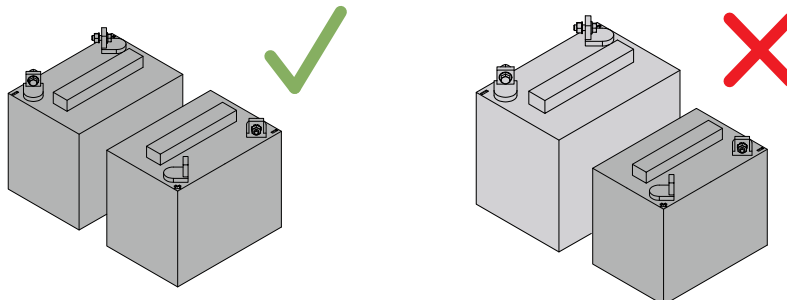

ELECTRICAL CONTROL CONSOLE CONNECTIONS - AGLEADER

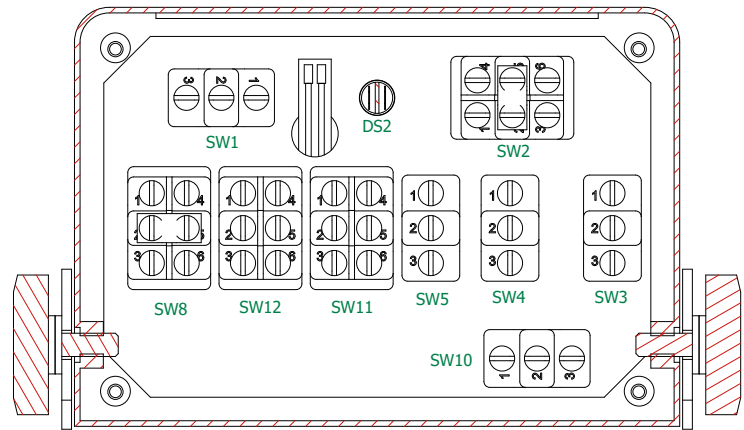
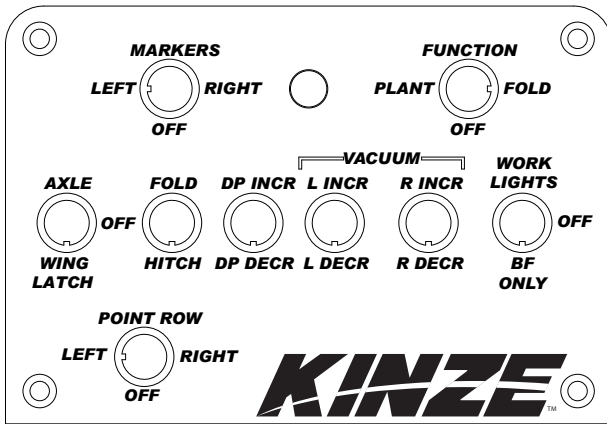

Wire Hookup Chart

Reference Designator	From	To	Color	Function
JP1	SW2-2	SW2-5		Jumper 1
JP2	SW8-2	SW8-5		Jumper 2
W1	E1	SW2-1	Orange	Marker Left
	E2	SW2-3	White/Orange	Marker Right
	E3	SW3-3	Brown	Axle
	E4	SW3-1	White/Brown	Wing Hooks
	E5	SW4-3	Gray	Fold
	E6	SW4-1	White/Gray	Hitch
	E7	SW5-3	Green	PDP Increase
	E8	SW5-1	White/Green	PDP Decrease
	W9	TB4	Blue	L VAC Increase
	W10	TB5	White/Blue	L VAC Increase
	W11	TB6	Violet	R VAC Increase
	W12	TB7	White/Violet	R VAC Decrease
	E13	SW8-3	Yellow	Work Light - Tank
	E14	SW8-6	White/Yellow	Work Light - Marker
	E15	SW10-1	Pink	Point Row L
	E16	SW10-3	White/Pink	Point Row R
	W15	TB2	Black	Tractor Ground
	W16	TB2	Black	Tractor Ground
W17W2	TB2	Black	Tractor Ground	
W18	TB1	Red	Tractor Power	
W2	SW3-2	SW4-2	Red	Jumper Wire
W3	SW8-5	SW12-2	Red	Jumper Wire
W4	SW11-2	SW12-2	Red	Jumper Wire

(Continued on next page)

Wire Hookup Chart (Continued)				
Reference Designator	From	To	Color	Function
W5	SW5-2	SW11-2	Red	Jumper Wire
W6	SW8-1	SW8-3	Red	Jumper Wire
W7	SW1-3	SW2-5	Red	Jumper Wire
W8	SW1-1	SW4-2	Red	Jumper Wire
W9	SW1-2	TB1	Red	Tractor Power
W10	SW8-2	TB1	Red	Tractor Power
W11	SW2-4	TB3	Red	Marker LED
W12	SW2-6	TB3	Red	Marker LED
W13	DS2(+)	TB3	Red	Marker LED
W14	DS2(-)	SW12-5	Black	Tractor Ground
W15	SW10-2	TB1	Red	Tractor Power
W16	SW11-3	TB4	Blue	L VAC Increase
W17	SW11-4	TB4	Blue	L VAC Increase
W18	SW11-1	TB5	White/ Blue	L VAC Decrease
W19	SW11-6	TB5	White/ Blue	L VAC Decrease
W20	SW12-3	TB6	Violet	R VAC Increase
W21	SW12-4	TB6	Violet	R VAC Increase
W22	SW12-1	TB7	White/ Violet	R VAC Decrease
W23	SW12-6	TB7	White/ Violet	R VAC Decrease
W24	SW11-5	TB2	Black	Tractor Ground
W25	SW11-5	SW12-5	Black	Jumper Wire
U1	Red	TB1	Red	Tractor Power
	Black	TB2	Black	Tractor Ground
	Yellow	DS1-1	Yellow	Display Light
	Orange	DS1-2	Orange	Display Light

CABLES AND HARNESSSES

This section includes information on planter cable and harness connections, make up and wiring for troubleshooting, maintenance and repair purposes.

DANGER

Before attempting to repair electrical wiring, make sure the harness or cable in question is disconnected from the battery or any other power source. Failing to do so might lead to serious injury.

Worklights Relay Cable

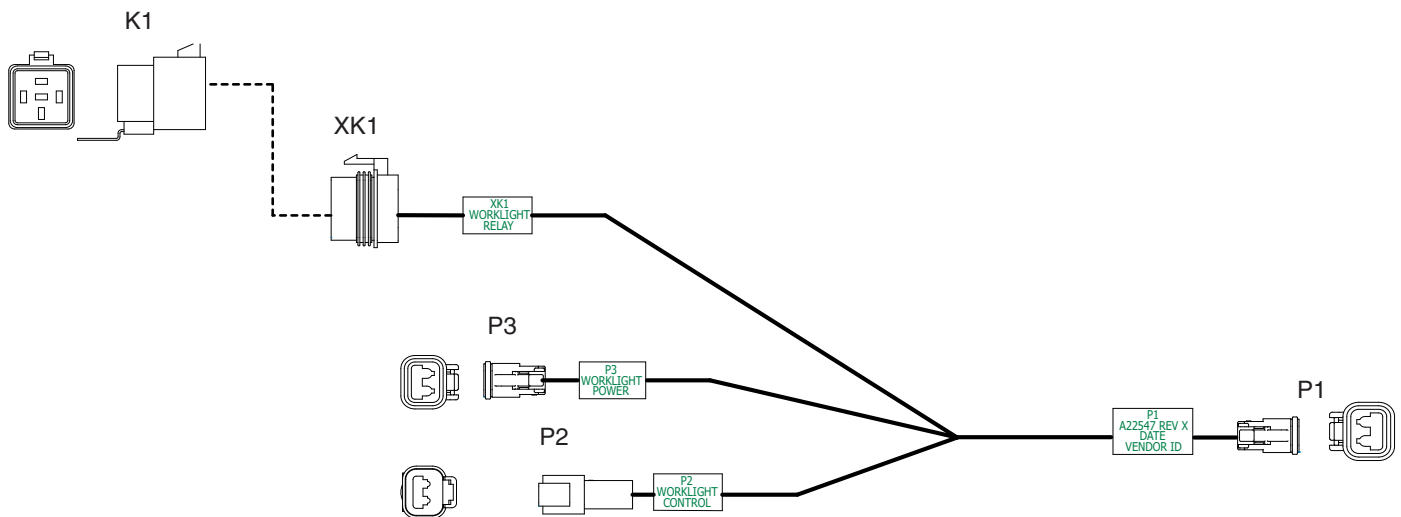

P/N A22547				
Signal	Wire Gauge	Color	From	To
Worklight Power -	16	Blue	P3-1	P1-1
Worklight Power +	16	Red	P3-2	XK1-30
Relay Ground	16	Black	P2-1	XK1-85
Relay 12V	16	Blue	P2-2	XK1-86
Worklight Power +	16	Red	XK1-87	P1-2

ETHERNET CABLES

Color	From	To
White/Orange	P1-1	P2-1
White/Green	P1-2	P2-2
Orange	P1-3	P2-3
Green	P1-4	P2-4

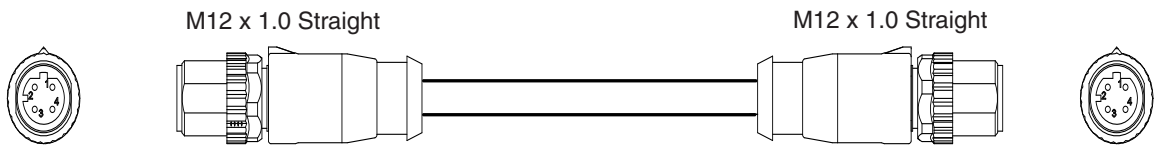

Ethernet Cable	
Part Number	Description
A22554-	Ethernet Ca CAT 5E (M12 STR-M12 STR)

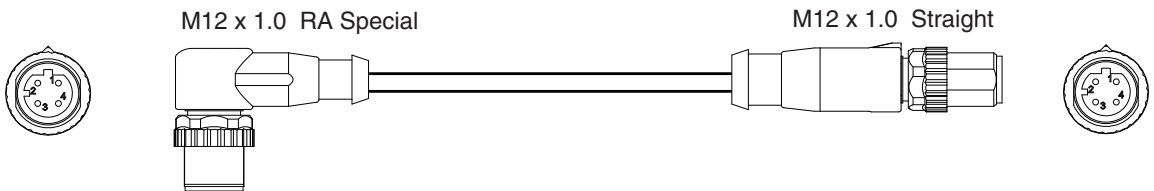

Ethernet Cable	
Part Number	Description
A22555-	Ethernet Ca CAT 5E (M12 RA-M12 STR)

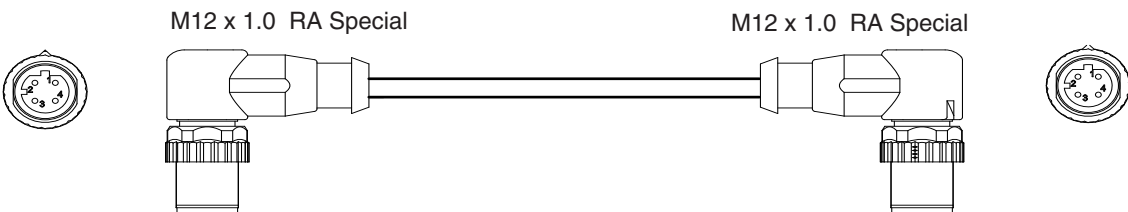

Ethernet Cable	
Part Number	Description
A22556-	Ethernet Ca CAT 5E (M12 RA-M12 RA)

Continue on the next page.

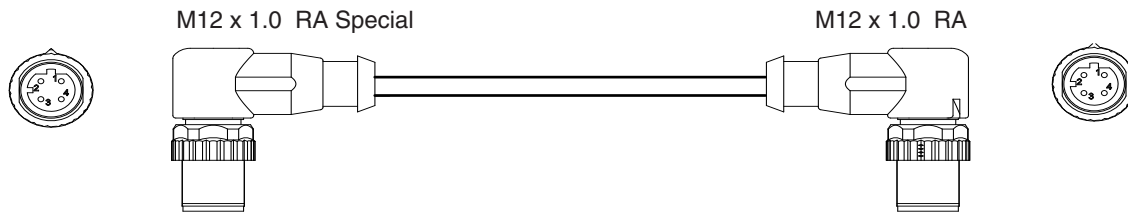

Ethernet Cable	
Part Number	Description
A24869-	Ethernet Ca CAT 5E (M12 RA-M12 RA)

12V Tail Light Harness

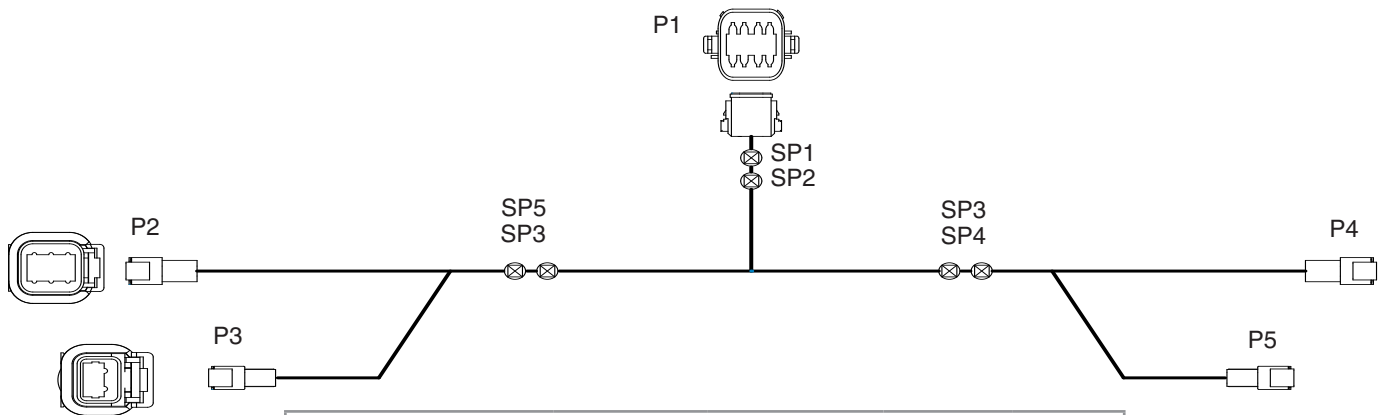

P/N A25159				
Signal	Wire Gauge	Color	From	To
LH FASH	16	YELLOW	P1-1	P2-4
FOG	16	BLUE	P1-2	P2-5
GND	16	WHITE	P1-3	SP1
RH FLASH	16	GREEN	P1-4	P4-4
RH TAILLIGHT	16	BROWN	P1-5	SP6
STOP LIGHTS	16	RED	P1-6	SP2
LH TAILLIGHT	16	BLACK	P1-7	SP5
GND	16	WHITE	SP1	SP3
GND	16	WHITE	SP1	SP4
STOP LIGHTS	16	RED	SP2	P2-2
STOP LIGHTS	16	RED	SP2	P4-2
GND	16	WHITE	SP3	P2-6
GND	16	WHITE	SP3	P3-1
GND	16	WHITE	SP4	P4-6
GND	16	WHITE	SP4	P5-1
LH TAILLIGHT	16	BLACK	SP5	P2-3
LH TAILLIGHT	16	BLACK	SP5	P3-2
RH TAILLIGHT	16	BROWN	SP6	P4-3
RH TAILLIGHT	16	BROWN	SP6	P5-2

Pneumatic Downpressure Power Harness

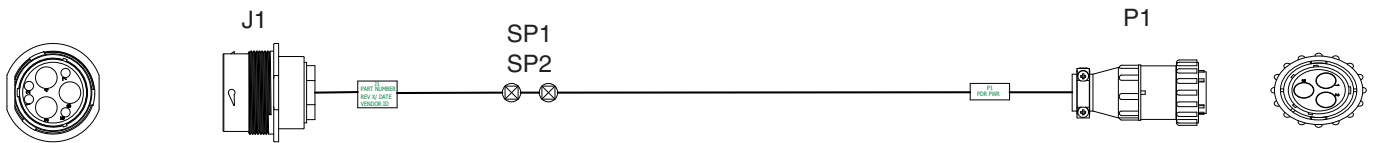

P/N A25158				
Signal	Wire Gauge	Color	From	To
PDP Power	4	RED	J1-3	SP1
PDP Ground	4	BLACK	J1-4	SP2
PDP Power	8	RED	SP1	P1-1
PDP Ground	8	BLACK	SP2	P1-2

Row Unit Power Extension Harness

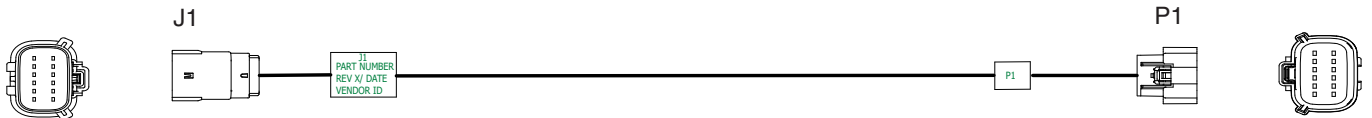

P/N A25029				
Signal	Wire Gauge	Color	FROM	TO
Power	16	RED	J1-1	P1-1
Ground	16	BLACK	J1-2	P1-2
Power	16	RED	J1-3	P1-3
Ground	16	BLACK	J1-4	P1-4
Strapping	20	YELLOW	J1-5	P1-5
Strapping	20	ORANGE	J1-6	P1-6
Strapping	20	WHITE	J1-7	P1-7
Strapping	20	GREEN	J1-8	P1-8
Strapping	20	BLUE	J1-9	P1-9
Strapping	20	VIOLET	J1-10	P1-10
Strapping	20	BLUE/RED	J1-11	P1-11
Strapping	20	BROWN	J1-12	P1-12

Tail Light Harness

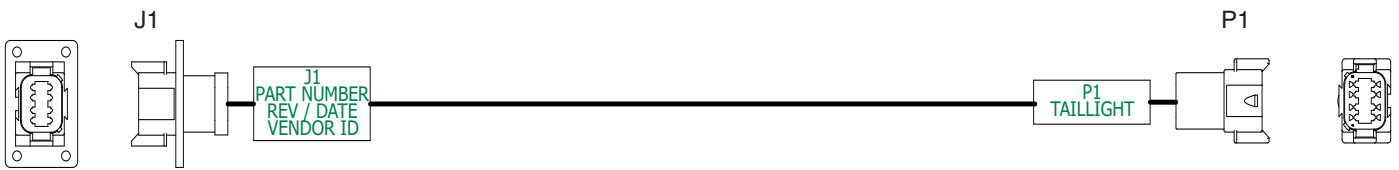

P/N A25160				
Signal	Wire Gauge	Color	From	To
LH FLASH	16	YELLOW	J1-1	P1-1
FOG	16	BLUE	J1-2	P1-2
GND	16	WHITE	J1-3	P1-3
RH FLASH	16	GREEN	J1-4	P1-4
RH TAIL LIGHT	16	BROWN	J1-5	P1-5
STOP LIGHTS	16	RED	J1-6	P1-6
LH TAIL LIGHT	16	BLACK	J1-7	P1-7

Axle Position Relay Harness

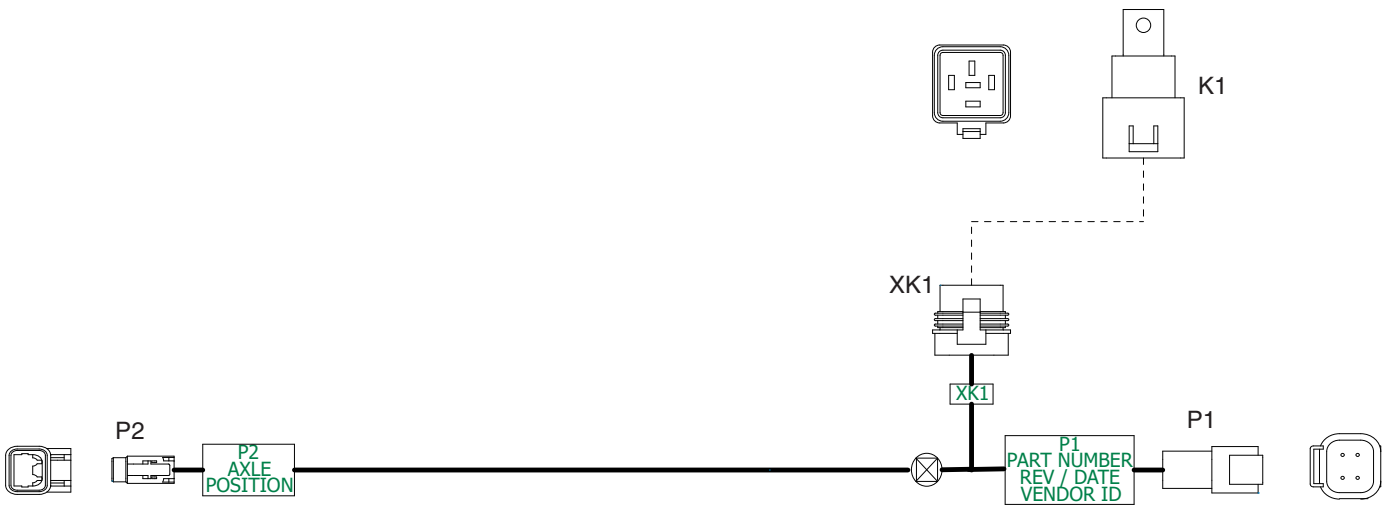

P/N A25166				
Signal	Wire Gauge	Color	From	To
PWR IN+	16	RED	P1-1	SP1
GND	16	BLACK	P1-2	XK1-85
PWR OUT+	16	RED	P1-4	XK1-87A
PWR IN+	16	RED	SP1	P2-1
PWR IN+	16	RED	SP1	XK1-30
SIGNAL	16	BLUE	P2-2	XK1-86

Row Unit Seed Meter Harness

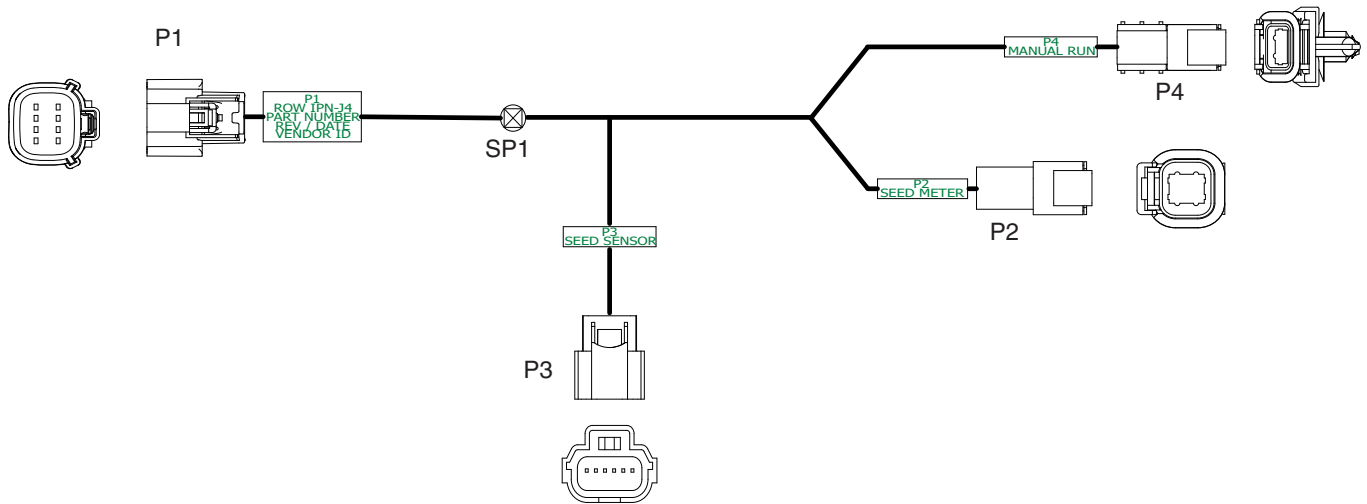

P/N A25203				
Signal	Wire Gauge	Color	From	To
Seed Meter Motor 1+	18	RED	P1-1	P2-1
Seed Meter Motor 1-	18	WHITE	P1-2	P2-2
Seed Meter Motor 2-	18	BLACK	P1-3	P2-4
Seed Meter Motor 2+	18	GREEN	P1-4	P2-3
Seed Sensor (Power)	18 TXL	RED	P1-5	P3-1
Ground	18	BLACK	P1-6	SP1
Seed Sensor (Lin)	18 TXL	BLUE	P1-7	P3-2
Seed Sensor (Ground)	18 TXL	BLACK	SP1	P3-6
Manual Run (Ground)	18	BLACK	SP1	P4-1
Manual Run (Input)	18	RED	P1-8	P4-2

Wing IPP Harness

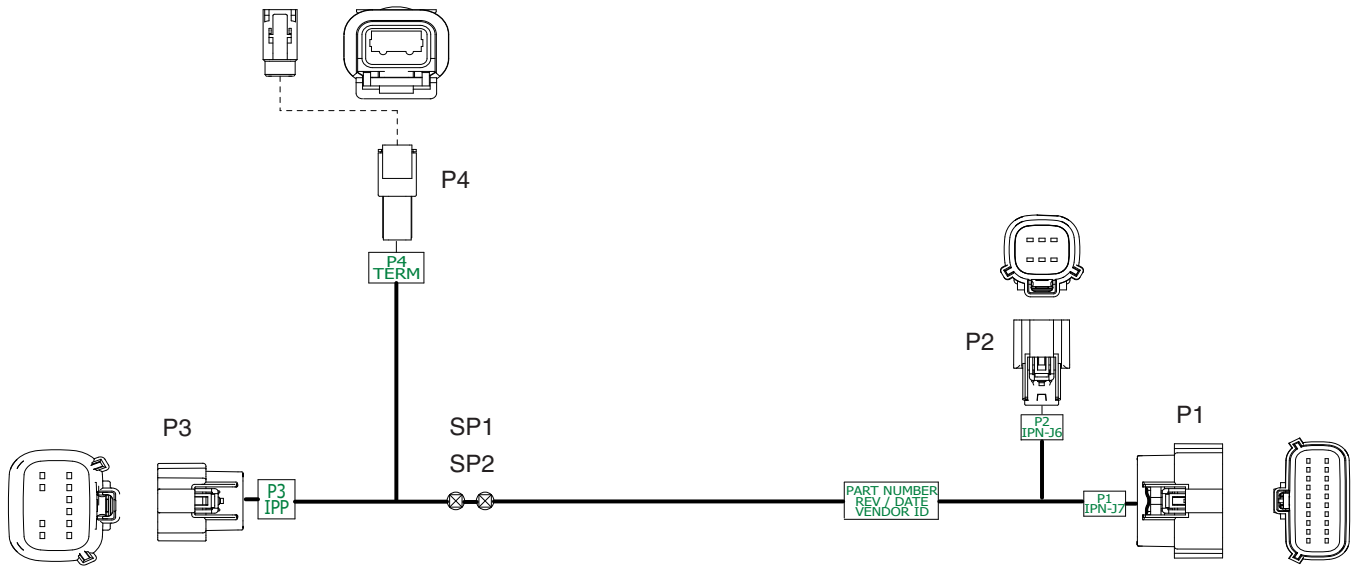

P/N A25214				
Signal	Wire Gauge	Color	From	To
RS232 RX	18(TP)	ORN	P1-1	P3-1
RS232 TX	18(TP)	BRN	P1-2	P3-2
CAN HI	18(TP)	YEL	P2-1	SP1
CAN LO	18(TP)	GRN	P2-2	SP2
Power	16	RED	P2-3	P3-12
Ground	16	BLK	P2-4	P3-6
IPP Software Update	18	BLU	P2-5	P3-11
CAN HI	18(TP)	YEL	SP1	P3-5
CAN LO	18(TP)	GRN	SP2	P3-4
CAN HI	18(TP)	YEL	SP1	P4-1
CAN LO	18(TP)	GRN	SP2	P4-2

Power Harness

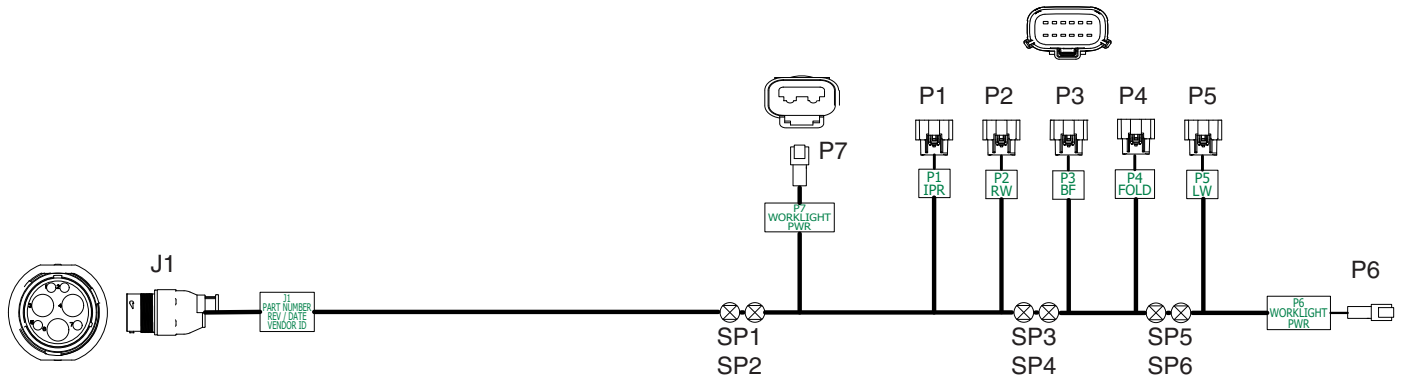

P/N A25588				
Signal	Wire Gauge	Color	From	To
12V DC+	6	RED	J1-3	SP1
12V DC-	6	BLACK	J1-4	SP2
WORKLIGHT (PWR)	16	RED	SP1	P7-2
IPR (PWR)	16	RED	SP1	P1-1
(PWR)	8	RED	SP1	SP3
WORKLIGHT (GND)	16	BLACK	SP2	P7-1
IPR (GND)	16	BLACK	SP2	P1-2
(GND)	8	BLACK	SP2	SP4
RW IPN (PWR)	16	RED	SP3	P2-1
RW IPN (PWR)	16	RED	SP3	P2-3
BF IPN (PWR)	16	RED	SP3	P3-1
BF IPN (PWR)	16	RED	SP3	P3-3
(PWR)	12	RED	SP3	SP5
RW IPN (GND)	16	BLACK	SP4	P2-2
RW IPN (GND)	16	BLACK	SP4	P2-4
BF IPN (GND)	16	BLACK	SP4	P3-2
BF IPN (GND)	16	BLACK	SP4	P3-4
(GND)	12	BLACK	SP4	SP6
FOLD (PWR)	16	RED	SP5	P4-1
FOLD (PWR)	16	RED	SP5	P4-3
LW IPN (PWR)	16	RED	SP5	P5-1
LW IPN (PWR)	16	RED	SP5	P5-3
WORKLIGHT (PWR)	16	RED	SP5	P6-2
FOLD (GND)	16	BLACK	SP6	P4-2
FOLD (GND)	16	BLACK	SP6	P4-4
LW IPN (GND)	16	BLACK	SP6	P5-2
LW IPN (GND)	16	BLACK	SP6	P5-4
WORKLIGHT (GND)	16	BLACK	SP6	P6-1

Left Wing IPN Harness

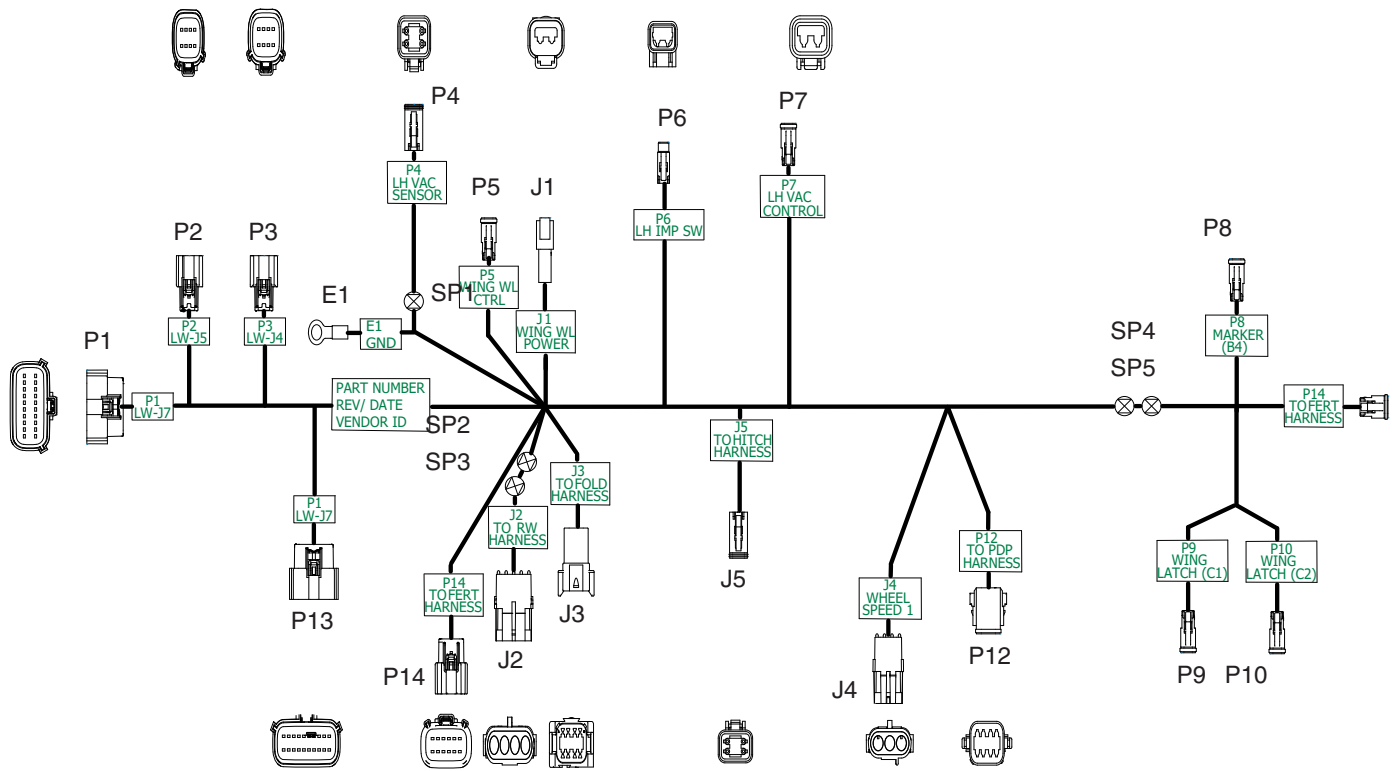

P/N A25589				
Signal	Wire Gauge	Color	From	To
PDP DECREASE (+)	16	VIOLENT	P1-3	P12-3
PDP DECREASE (-)	16	BROWN	P1-4	P12-4
WING WORKLIGHT RELAY (+)	16	RED	P1-7	P5-2
WING WORKLIGHT RELAY (-)	16	BLACK	P1-8	P5-1
PDP SENSOR (SIG)	18	WHITE	P1-16	P12-7
PDP SENSOR (GND)	18	BLACK	P1-19	P12-6
PDP SENSOR (PWR)	18	ORANGE	P1-20	P12-5
PDP INCREASE (+)	16	RED	P2-1	P12-1
PDP INCREASE (-)	16	YELLOW	P2-2	P12-2
LEFT VAC SENSOR (PWR)	18	ORNANGE	P2-5	P4-2
LEFT VAC SENSOR (GND)	18	BLACK	P2-6	SP1
LEFT VAC SENSOR (SIG)	18	WHITE	P2-7	P4-4
LEFT VAC FAN SOLENOID (+)	16	RED	P3-1	P7-1
LEFT VAC FAN SOLENOID (-)	16	BLACK	P3-2	P7-2
LEFT IMPLEMENT SWITCH (PWR)	18	BROWN	P3-5	P6-1
LEFT IMPLEMENT SWITCH (SIG)	18	GREEN	P3-7	P6-2
LEFT VAC SENSOR (GND)	18	BLACK	SP1	P4-1

PLANTER GROUND	18	BLACK	SP1	E1
WING WORKLIGHT (-)	16	BLACK	J1-1	SP2
WING WORKLIGHT (+)	16	RED	J1-2	SP3
LEFT WING WORKLIGHT (-)	16	BLACK	SP2	P11-1
RIGHT WING WORKLIGHT (-)	16	BLACK	SP2	J2-B
LEFT WING WORKLIGHT (+)	16	RED	SP3	P11-2
RIGHT WING WORKLIGHT (+)	16	RED	SP3	J2-A
LEFT MARKER SOLENOID (+)	16	RED	J2-C	P8-1
LEFT MARKER SOLENOID (-)	16	BLACK	J2-D	P8-2
WHEEL SPEED #1 (PWR)	18	RED	J3-1	J4-A
WHEEL SPEED #1 (GND)	18	BLACK	J3-2	J4-B
WHEEL SPEED #1 (FREQ)	18	WHITE	J3-3	J4-C
LEFT WING LATCH (+)	16	RED	J3-4	SP4
LEFT WING LATCH (-)	16	BLACK	J3-5	SP5
LEFT WING LATCH (+)	16	RED	SP4	P9-1
LEFT WING LATCH (+)	16	RED	SP4	P10-1
LEFT WING LATCH (-)	16	BLACK	SP5	P9-2
LEFT WING LATCH (-)	16	BLACK	SP5	P10-2
DRAWBAR HITCH SOLENOID (+)	16	WHITE	P13-3	J5-1
DRAWBAR HITCH SOLENOID (-)	16	GRAY	P13-4	J5-2
FERTILIZER PUMP SOLENOID (+)	16	RED	P13-7	P14-1
FERTILIZER PUMP SOLENOID (-)	16	BLACK	P13-8	P14-2
FERT PUMP SHUTOFF (SIG)	18	BLUE	P13-13	P14-3
FERT FLOW METER (SIG)	18	WHITE	P13-15	P14-5
FERT LOW LEVEL SENSOR (SIG)	18	YELLOW	P13-16	P14-6
FERT LOW LEVEL/SHUTOFF (GND)	18	BLACK	P13-17	P14-7
FERT LOW LEVEL/SHUTOFF (PWR)	18	RED	P13-18	P14-8
FERT FLOW METER (GND)	18	BLACK	P13-19	P14-9
FERT FLOW METER (PWR)	18	ORANGE	P13-20	P14-10
FOLD (+)	16	RED	J3-7	J5-3
FOLD (-)	16	BLACK	J3-8	J5-4

Right Wing IPN Harness

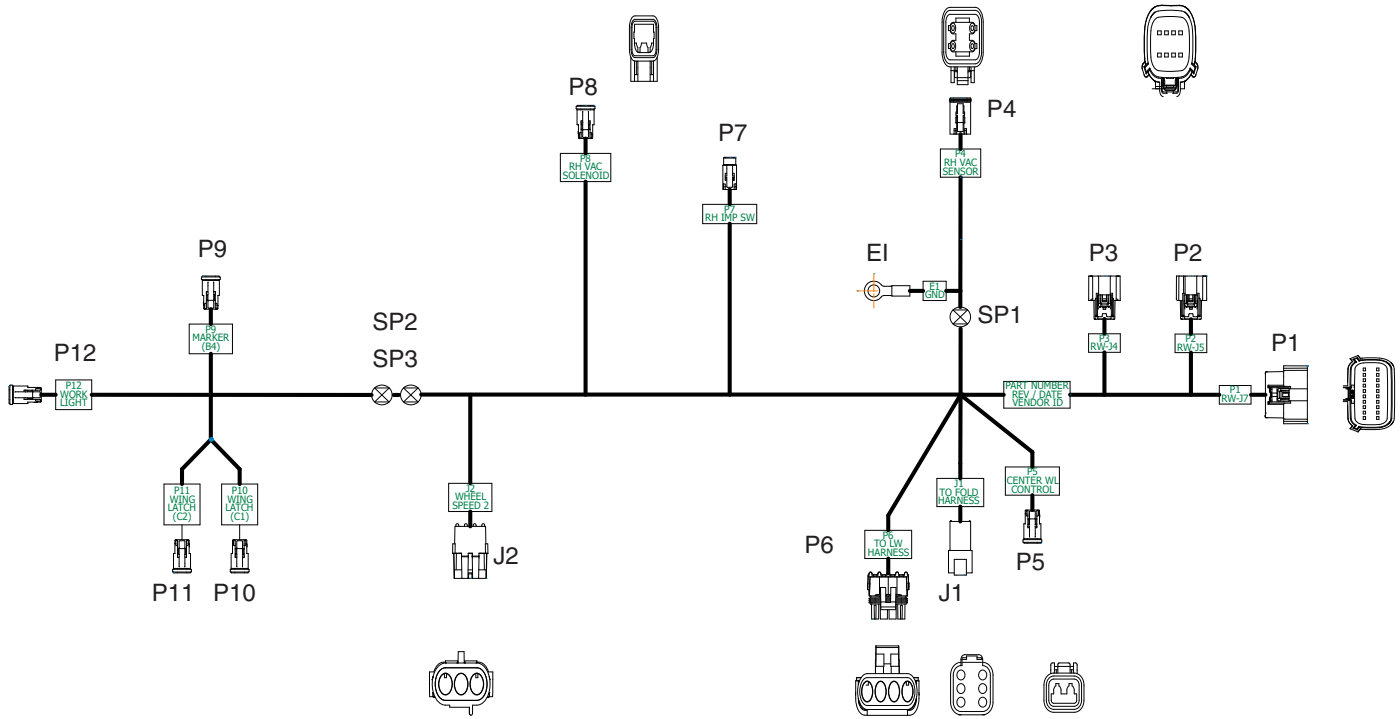

P/N A25590				
Signal	Wire Gauge	Color	From	To
LEFT MARKER SOLENOID (+)	16	RED	P1-3	P6-C
LEFT MARKER SOLENOID (-)	16	BLACK	P1-4	P6-D
CENTER WORK LIGHT RELAY (+)	16	RED	P1-7	P5-2
CENTER WORK LIGHT RELAY (-)	16	BLACK	P1-8	P5-1
RIGHT MARKER SOLENOID (+)	16	RED	P2-1	P9-1
RIGHT MARKER SOLENOID (-)	16	BLACK	P2-2	P9-2
RIGHT VAC PRESS SENSOR (PWR)	18	WHITE	P2-5	P4-2
RIGHT VAC PRESS SENSOR (GND)	18	BLACK	P2-6	SP1
RIGHT VAC PRESS SENSOR (SIG)	18	YELLOW	P2-7	P4-4
RIGHT VAC FAN SOLENOID (+)	16	RED	P3-1	P8-1
RIGHT VAC FAN SOLENOID (-)	16	BLACK	P3-2	P8-2
RIGHT IMPLEMENT SWITCH (PWR)	18	BROWN	P3-5	P7-1
RIGHT IMPLEMENT SWITCH (SIG)	18	GREEN	P3-7	P7-2
RIGHT VAC PRESS SENSOR (GND)	18	BLACK	SP1	P4-1
PLANTER GROUND	18	BLACK	SP1	E1
RIGHT WING LATCH (+)	16	RED	J1-4	SP2
RIGHT WING LATCH (-)	16	BLACK	J1-5	SP3
RIGHT WING LATCH (+)	16	RED	SP2	P10-1
RIGHT WING LATCH (+)	16	RED	SP2	P11-1
RIGHT WING LATCH (-)	16	BLACK	SP3	P10-2
RIGHT WING LATCH (-)	16	BLACK	SP3	P11-2

WHEEL SPEED #2 (PWR)	18	RED	J1-1	J2-A
WHEEL SPEED #2 (GND)	18	BLACK	J1-2	J2-B
WHEEL SPEED #2 (FREQ)	18	WHITE	J1-3	J2-C
WING WORKLIGHT RH (+)	16	BLACK	P6-A	P12-2
WING WORKLIGHT RH (-)	16	RED	P6-B	P12-1

Hitch Drawbar Harness

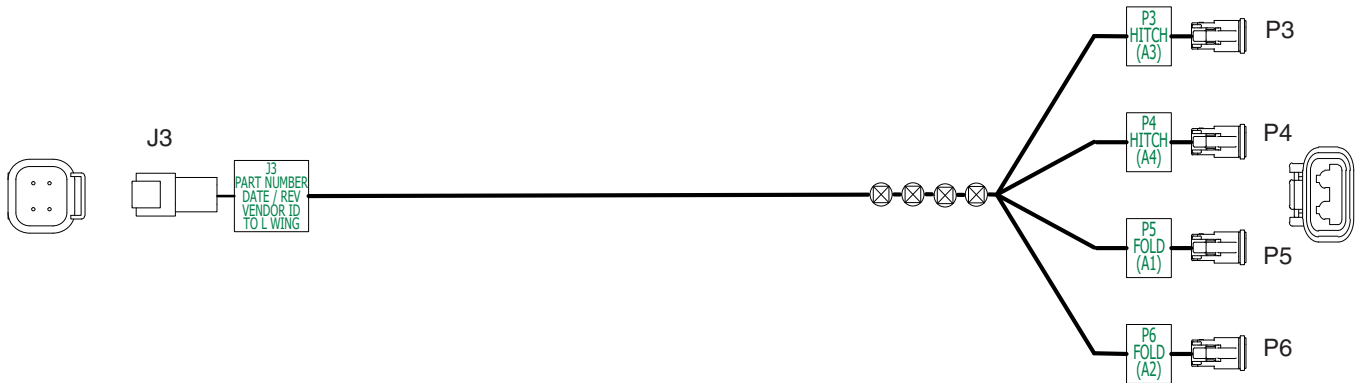

P/N A25591				
Signal	Wire Gauge	Color	From	To
DRAWBAR HITCH SOLENOID +	16	WHITE	J3-1	SP1
DRAWBAR HITCH SOLENOID -	16	GREEN	J3-2	SP2
WING FOLD SOLENOID+	16	RED	J3-3	SP3
WING FOLD SOLENOID-	16	BLACK	J3-4	SP4
DRAWBAR HITCH SOLENOID +	16	WHITE	SP1	P3-1
DRAWBAR HITCH SOLENOID +	16	WHITE	SP1	P4-1
DRAWBAR HITCH SOLENOID -	16	GREEN	SP2	P3-2
DRAWBAR HITCH SOLENOID -	16	GREEN	SP2	P4-2
WING FOLD SOLENOID+	16	RED	SP3	P5-1
WING FOLD SOLENOID+	16	RED	SP3	P6-1
WING FOLD SOLENOID-	16	BLACK	SP4	P5-2
WING FOLD SOLENOID-	16	BLACK	SP4	P6-2

Fold IPN Harness

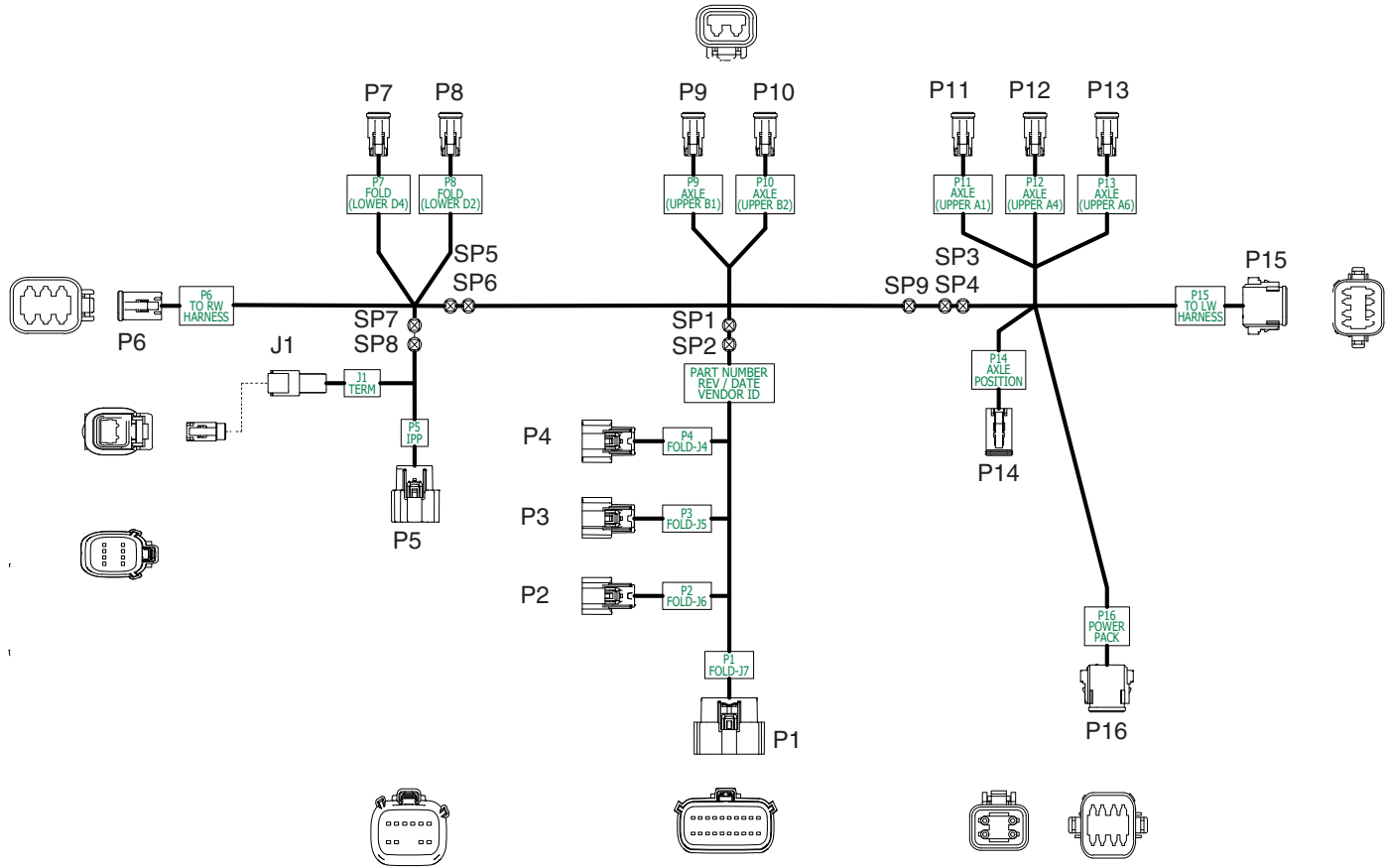

P/N A25592				
Signal	Wire Gauge	Color	From	To
IPP UPDATE/DEBUG (RS232 RX)	18 (TP)	ORANGE	P1-1	P5-1
IPP UPDATE/DEBUG (RS232 TX)	18 (TP)	BROWN	P1-2	P5-2
FOLD (+)	16	RED	P1-3	SP3
FOLD (-)	16	BLACK	P1-4	SP4
AXLE RELAY INPUT (+)	16	RED	P1-7	P14-1
AXLE RELAY (-)	16	BLACK	P1-8	SP9
RU PWR FEEDBACK FROM POWER PACK	20	YELLOW	P1-13	P16-4
BATTERY 1 VOLTAGE	14	ORANGE	P1-14	P16-7
SPEED WHEEL #2 (FREQ)	18	WHITE	P1-15	P6-3
BATTERY 2 VOLTAGE	14	BLUE	P1-16	P16-8
SPEED WHEEL #2 (GND)	18	BLACK	P1-17	P6-2
SPEED WHEEL #2 (PWR)	18	RED	P1-18	P6-1
RU POWER RELAY (GND)	16	BLACK	P1-19	P16-2
RU POWER RELAY (PWR)	16	RED	P1-20	P16-1

IPP CAN HI	18 (TP)	YELLOW	P2-1	SP7
IPP CAN LO	18 (TP)	GREEN	P2-2	SP8
IPP PWR (+)	16	RED	P2-3	P5-12
IPP PWR (-)	16	BLACK	P2-4	P5-6
AXLE (+)	16	RED	P3-1	SP1
AXLE (-)	16	BLACK	P3-2	SP2
BATTERY PACK RELAY (PWR)	16	WHITE	P3-5	P16-5
BATTERY PACK RELAY (GND)	16	GREEN	P3-6	P16-6
SPEED WHEEL #1 (FREQ)	18	WHITE	P3-7	P15-3
WING LATCHES (+)	16	RED	P4-1	SP5
WING LATCHES (-)	16	BLACK	P4-2	SP6
SPEED WHEEL #1 (PWR)	18	RED	P4-5	P15-1
SPEED WHEEL #1 (GND)	18	BLACK	P4-6	P15-2
ALTERNATOR SENSE (FREQ)	16	BROWN	P4-8	P16-3
RIGHT WING LATCH (+)	16	RED	SP5	P6-4
AXLE (+)	16	RED	SP1	P9-1
AXLE (+)	16	RED	SP1	P10-1
LEFT WING LATCH (+)	16	RED	SP5	P15-4
RIGHT WING LATCH (-)	16	BLACK	SP6	P6-5
AXLE (-)	16	BLACK	SP2	P9-2
AXLE (-)	16	BLACK	SP2	P10-2
LEFT WING LATCH (-)	16	BLACK	SP6	P15-5
AXLE RELAY (-)	16	BLACK	SP9	P13-2
AXLE (+)	16	RED	SP1	P11-1
AXLE (+)	16	RED	SP1	P12-1
FOLD (+)	16	RED	SP3	P15-7
AXLE (-)	16	BLACK	SP2	P11-2
AXLE (-)	16	BLACK	SP2	P12-2
FOLD (-)	16	BLACK	SP4	P15-8
FOLD (+)	16	RED	SP3	P7-1
FOLD (+)	16	RED	SP3	P8-1
FOLD (-)	16	BLACK	SP4	P7-2
FOLD (-)	16	BLACK	SP4	P8-2
AXLE RELAY OUTPUT (+)	16	RED	P14-4	P13-1
IPP CAN H	18 (TP)	YELLOW	SP7	P5-5
IPP CAN L	18 (TP)	GREEN	SP8	P5-4
CAN HI TERMINATOR	18 (TP)	YELLOW	SP7	J1-1
CAN LO TERMINATOR	18 (TP)	GREEN	SP8	J1-2
AXLE RELAY (-)	16	BLACK	SP9	P14-2
IPP SOFTWARE UPDATE ENABLE	18	BLUE	P2-5	P5-11

Power Harness (1-9)

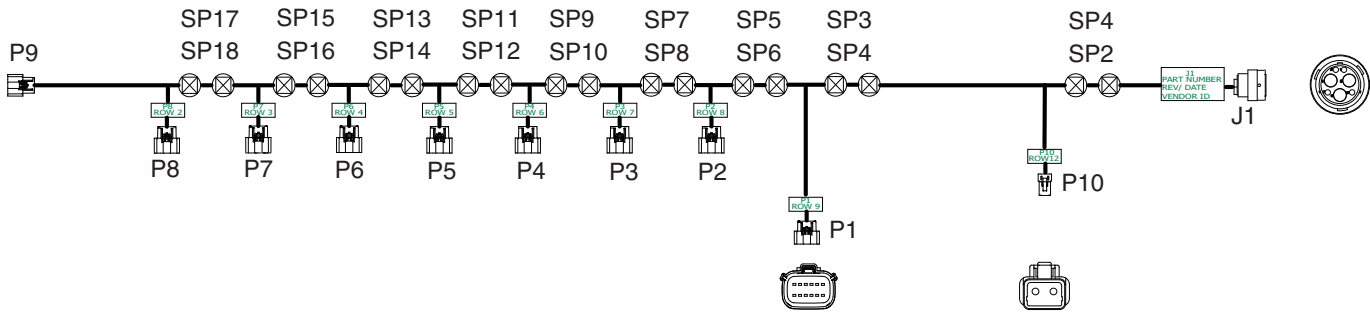

P/N A25596				
Signal	Wire Gauge	Color	From	To
PWR	4	RED	J1-6	SP1
GND	4	BLACK	J1-4	SP2
RU 10-12 (PWR)	10	RED	SP1	P10-1
PWR	4	RED	SP1	SP3
RU 10-12 (GND)	10	BLACK	SP2	P10-2
GND	4	BLACK	SP2	SP4
RU 9 (PWR)	16	RED	SP3	P1-1
RU 9 (PWR)	16	RED	SP3	P1-3
PWR	4	RED	SP3	SP5
RU 9 (GND)	16	BLACK	SP4	P1-2
RU 9 (GND)	16	BLACK	SP4	P1-4
GND	4	BLACK	SP4	SP6
RU 8 (PWR)	16	RED	SP5	P2-1
RU 8 (PWR)	16	RED	SP5	P2-3
PWR	6	RED	SP5	SP7
RU 8 (GND)	16	BLACK	SP6	P2-2
RU 8 (GND)	16	BLACK	SP6	P2-4
GND	6	BLACK	SP6	SP8
RU 7 (PWR)	16	RED	SP7	P3-1
RU 7 (PWR)	16	RED	SP7	P3-3
PWR	6	RED	SP7	SP9
RU 7 (GND)	16	BLACK	SP8	P3-2
RU 7 (GND)	16	BLACK	SP8	P3-4
GND	6	BLACK	SP8	SP10
RU 6 (PWR)	16	RED	SP9	P4-1
RU 6 (PWR)	16	RED	SP9	P4-3
PWR	8	RED	SP9	SP11
RU 6 (GND)	16	BLACK	SP10	P4-2
RU 6 (GND)	16	BLACK	SP10	P4-4
GND	8	BLACK	SP10	SP12

RU 5 (PWR)	16	RED	SP11	P5-1
RU 5 (PWR)	16	RED	SP11	P5-3
PWR	8	RED	SP11	SP13
RU 5 (GND)	16	BLACK	SP12	P5-2
RU 5 (GND)	16	BLACK	SP12	P5-4
GND	8	BLACK	SP12	SP14
RU 4 (PWR)	16	RED	SP13	P6-1
RU 4 (PWR)	16	RED	SP13	P6-3
PWR	10	RED	SP13	SP15
RU 4 (GND)	16	BLACK	SP14	P6-2
RU 4 (GND)	16	BLACK	SP14	P6-4
GND	10	BLACK	SP14	SP16
RU 3 (PWR)	16	RED	SP15	P7-1
RU 3 (PWR)	16	RED	SP15	P7-3
PWR	10	RED	SP15	SP17
RU 3 (GND)	16	BLACK	SP16	P7-2
RU 3 (GND)	16	BLACK	SP16	P7-4
GND	10	BLACK	SP16	SP18
RU 2 (PWR)	16	RED	SP17	P8-1
RU 2 (PWR)	16	RED	SP17	P8-3
RU 1 (PWR)	16	RED	SP17	P9-1
RU 1 (PWR)	16	RED	SP17	P9-3
RU 2 (GND)	16	BLACK	SP18	P8-2
RU 2 (GND)	16	BLACK	SP18	P8-4
RU 1 (GND)	16	BLACK	SP18	P9-2
RU 1 (GND)	16	BLACK	SP18	P9-4

Bulk Fill IPN Harness

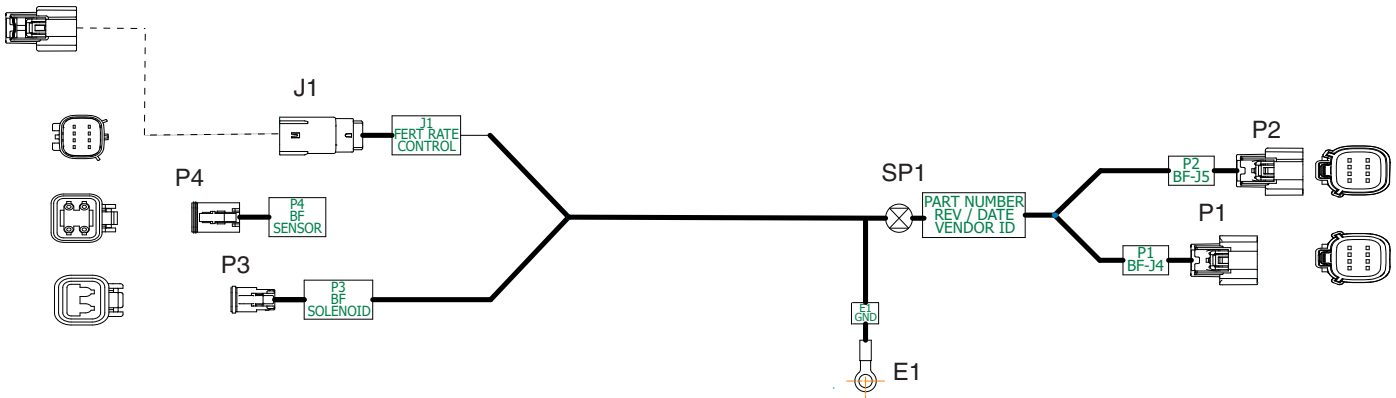

P/N A25593				
Signal	Wire Gauge	Color	From	To
BULK FILL FAN SOLENOID +	16	RED	P1-1	P3-1
BULK FILL FAN SOLENOID -	16	BLACK	P1-2	P3-2
FERTILIZER RATE INCREASE	18	YELLOW	P2-1	J1-1
FERTILIZER RATE DECREASE	18	GREEN	P2-2	J1-2
BULK FILL PRESS SENSOR (PWR)	18	ORANGE	P2-5	P4-2
BULK FILL PRESS SENSOR (GND)	18	BLACK	P2-6	SP1
BULK FILL PRESS SENSOR (SIG)	18	WHITE	P2-7	P4-4
BULK FILL PRESS SENSOR (GND)	18	BLACK	SP1	P4-1
PLANTER GND	18	BLACK	SP1	E1

12V DL Power Harness

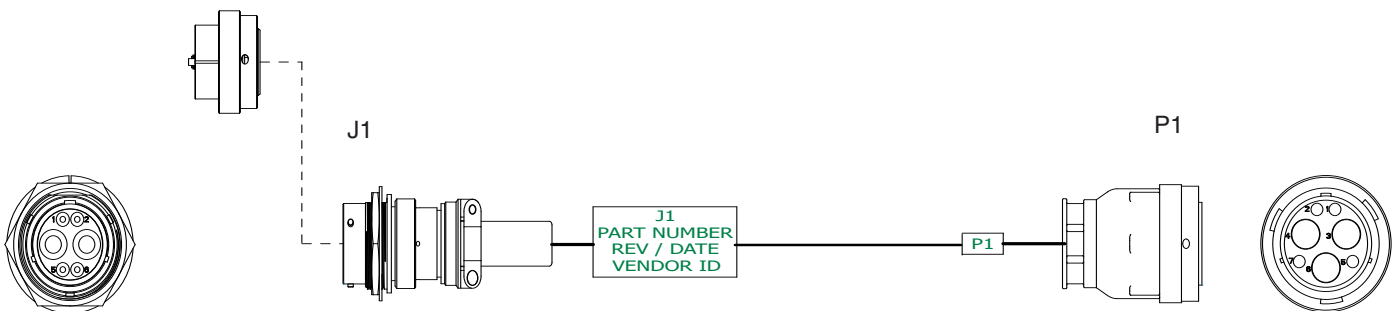

P/N A25626				
Signal	Wire Gauge	Color	From	To
12V DC+	6	RED	J1-3	P1-3
12V DC-	6	BLACK	J1-4	P1-4

24V Power Harness (16-24)

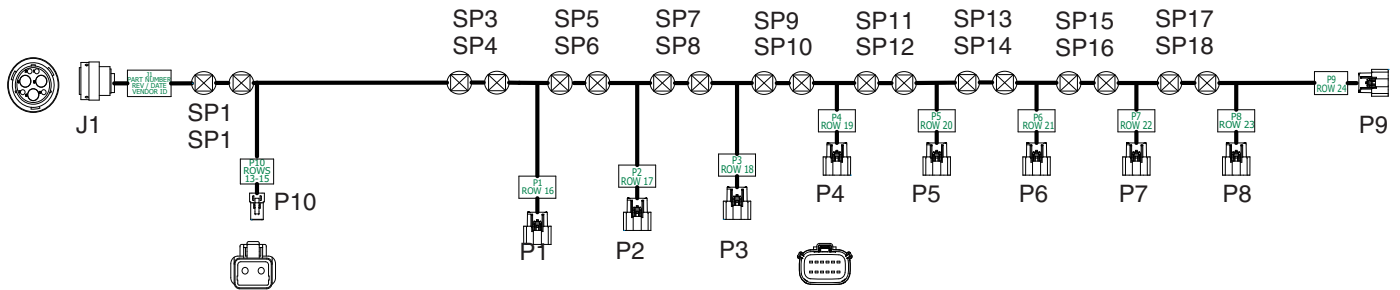

P/N A25597				
Signal	Wire Gauge	Color	From	To
PWR	4	RED	J1-6	SP1
GND	4	BLACK	J1-4	SP2
RU 13-15 (PWR)	10	RED	SP1	P10-1
PWR	4	RED	SP1	SP3
RU 13-15 (GND)	10	BLACK	SP2	P10-2
GND	4	BLACK	SP2	SP4
RU 16 (PWR)	16	RED	SP3	P1-1
RU 16 (PWR)	16	RED	SP3	P1-3
PWR	4	RED	SP3	SP5
RU 16 (GND)	16	BLACK	SP4	P1-2
RU 16 (GND)	16	BLACK	SP4	P1-4
GND	4	BLACK	SP4	SP6
RU 17 (PWR)	16	RED	SP5	P2-1
RU 17 (PWR)	16	RED	SP5	P2-3
PWR	6	RED	SP5	SP7
RU 17 (GND)	16	BLACK	SP6	P2-2
RU 17 (GND)	16	BLACK	SP6	P2-4
GND	6	BLACK	SP6	SP8
RU 18 (PWR)	16	RED	SP7	P3-1
RU 18 (PWR)	16	RED	SP7	P3-3
PWR	6	RED	SP7	SP9
RU 18 (GND)	16	BLACK	SP8	P3-2
RU 18 (GND)	16	BLACK	SP8	P3-4
GND	6	BLACK	SP8	SP10
RU 19 (PWR)	16	RED	SP9	P4-1
RU 19 (PWR)	16	RED	SP9	P4-3
PWR	8	RED	SP9	SP11
RU 19 (GND)	16	BLACK	SP10	P4-2
RU 19 (GND)	16	BLACK	SP10	P4-4
GND	8	BLACK	SP10	SP12
RU 20 (PWR)	16	RED	SP11	P5-1

RU 20 (PWR)	16	RED	SP11	P5-3
PWR	8	RED	SP11	SP13
RU 20 (GND)	16	BLACK	SP12	P5-2
RU 20 (GND)	16	BLACK	SP12	P5-4
GND	8	BLACK	SP12	SP14
RU 21 (PWR)	16	RED	SP13	P6-1
RU 21 (PWR)	16	RED	SP13	P6-3
PWR	10	RED	SP13	SP15
RU 21 (GND)	16	BLACK	SP14	P6-2
RU 21 (GND)	16	BLACK	SP14	P6-4
GND	10	BLACK	SP14	SP16
RU 22 (PWR)	16	RED	SP15	P7-1
RU 22 (PWR)	16	RED	SP15	P7-3
PWR	10	RED	SP15	SP17
RU 22 (GND)	16	BLACK	SP16	P7-2
RU 22 (GND)	16	BLACK	SP16	P7-4
GND	10	BLACK	SP16	SP18
RU 23 (PWR)	16	RED	SP17	P8-1
RU 23 (PWR)	16	RED	SP17	P8-3
RU 23 (GND)	16	BLACK	SP18	P8-2
RU 23 (GND)	16	BLACK	SP18	P8-4
RU 24 (PWR)	16	RED	SP17	P9-1
RU 24 (PWR)	16	RED	SP17	P9-3
RU 24 (GND)	16	BLACK	SP18	P9-2
RU 24 (GND)	16	BLACK	SP18	P9-4

24V Power Harness (10-12)

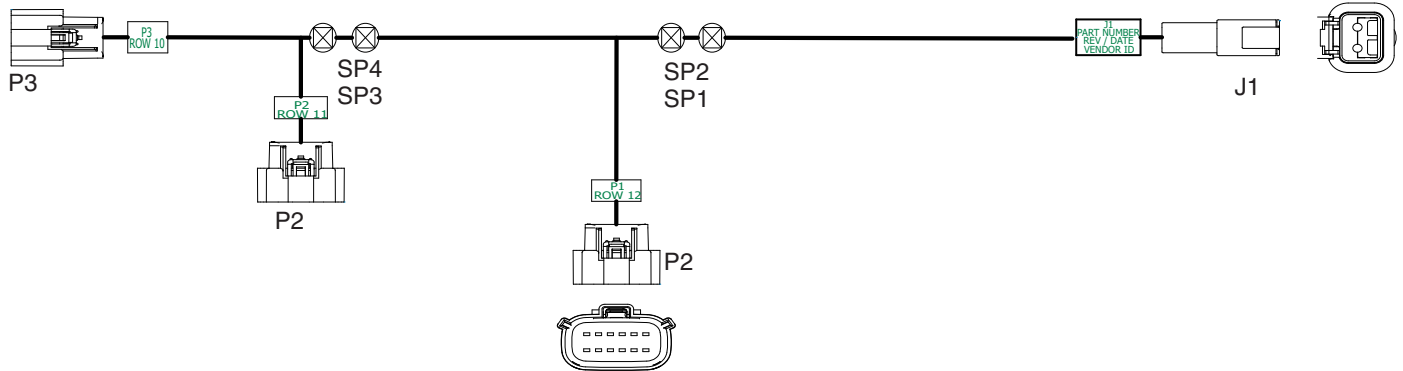

P/N A25598				
Signal	Wire Gauge	Color	From	To
PWR	10	RED	J1-1	SP1
GND	10	BLACK	J1-2	SP2
ROW 12 (PWR)	16	RED	SP1	P1-1
ROW 12 (PWR)	16	RED	SP1	P1-3
PWR	10	RED	SP1	SP3
ROW 12 (GND)	16	BLACK	SP2	P1-2
ROW 12 (GND)	16	BLACK	SP2	P1-4
GND	10	BLACK	SP2	SP4
ROW 11 (PWR)	16	RED	SP3	P2-1
ROW 11 (PWR)	16	RED	SP3	P2-3
ROW 10 (PWR)	16	RED	SP3	P3-1
ROW 10 (PWR)	16	RED	SP3	P3-3
ROW 11 (GND)	16	BLACK	SP4	P2-2
ROW 11 (GND)	16	BLACK	SP4	P2-4
ROW 10 (GND)	16	BLACK	SP4	P3-2
ROW 10 (GND)	16	BLACK	SP4	P3-4

24V Power Harness (13-15)

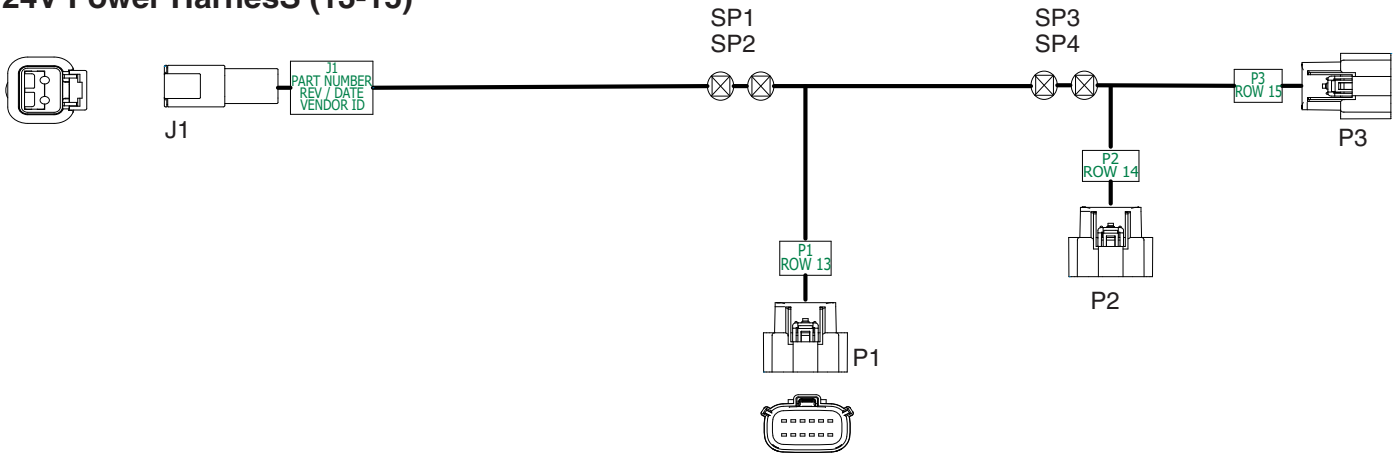

P/N A25599				
Signal	Wire Gauge	Color	From	To
PWR	10	RED	J1-1	SP1
GND	10	BLACK	J1-2	SP2
ROW 13 (PWR)	16	RED	SP1	P1-1
ROW 13 (PWR)	16	RED	SP1	P1-3
PWR	10	RED	SP1	SP3
ROW 13 (GND)	16	BLACK	SP2	P1-2
ROW 13 (GND)	16	BLACK	SP2	P1-4
GND	10	BLACK	SP2	SP4
ROW 14 (PWR)	16	RED	SP3	P2-1
ROW 14 (PWR)	16	RED	SP3	P2-3
ROW 15 (PWR)	16	RED	SP3	P3-1
ROW 15 (PWR)	16	RED	SP3	P3-3
ROW 14 (GND)	16	BLACK	SP4	P2-2
ROW 14 (GND)	16	BLACK	SP4	P2-4
ROW 15 (GND)	16	BLACK	SP4	P3-2
ROW 15 (GND)	16	BLACK	SP4	P3-4

24V Power Harness (13-15)

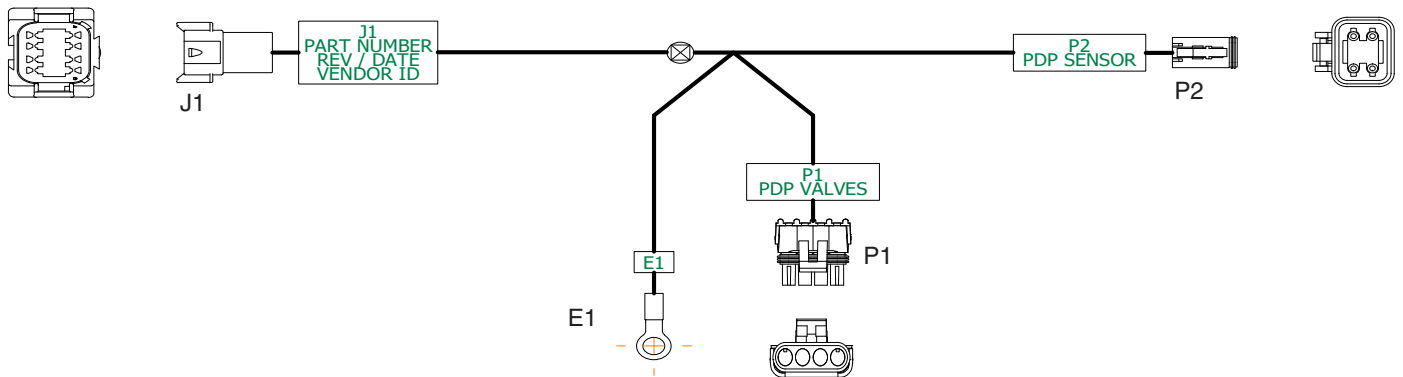

P/N A25653				
Signal	Wire Gauge	Color	From	To
PDP INCREASE (+)	16	RED	J1-1	P1-A
PDP INCREASE (-)	16	YELLOW	J1-2	P1-B
PDP DECREASE (+)	16	VIOLET	J1-3	P1-C
PDP DECREASE (-)	16	BROWN	J1-4	P1-D
PDP SENSOR (PWR)	18	ORANGE	J1-5	P2-2
PDP SENSOR (GND)	18	BLACK	J1-6	SP1
PDP SENSOR (SIGNAL)	18	WHITE	J1-7	P2-4
PDP SENSOR (GND)	18	BLACK	SP1	E1
PDP SENSOR (GND)	18	BLACK	SP1	P2-1

Harness Bulk Fill Scale

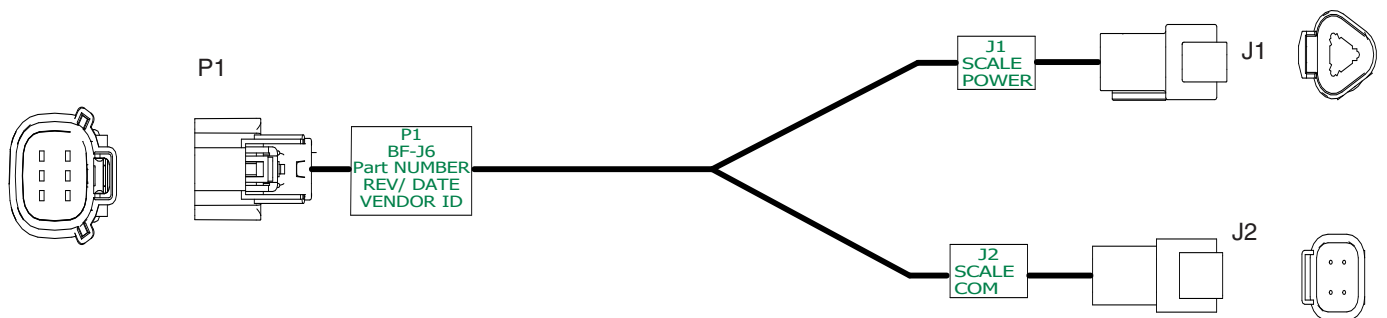

P/N A25218				
Signal	Wire Gauge	Color	From	To
BULK FILL SCALE (CAN H)	8	YELLOW	P1-1	J2-1
BULK FILL SCALE (CAN L)	8	GREEN	P1-2	J2-2
BULK FILL SCALE HEAD (PWR+)	8	RED	P1-3	J1-A
BULK FILL SCALE HEAD (PWR-)	8	BLACK	P1-4	J1-B

Bulk Fill Scale CAN Harness

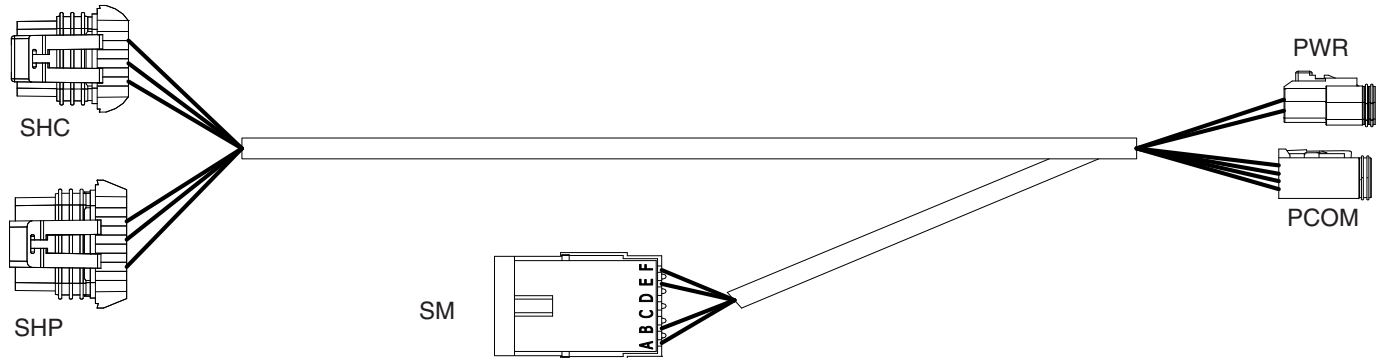

P/N A19388				
Signal	Wire Gauge	Color	From	To
PWR 12 VDC	16	RED	PWR-1	SHP-C
PWR 12 VDC	16	RED	PWR-1	SHP-E
PWR 12 VDC	16	RED	PWR-1	SM-A
Ground	16	BLACK	PWR-2	SHP-F
Ground	16	BLACK	PWR-2	SM-B
CAN H	18 TP	YELLOW	PCOM-1	SHC-A
CAN H	18 TP	YELLOW	PCOM-1	SM-E
CAN L	18 TP	GREEN	SHC-A	SM-E
CAN L	18 TP	GREEN	SHC-H	SM-F

Row Unit ESD Drain Harness

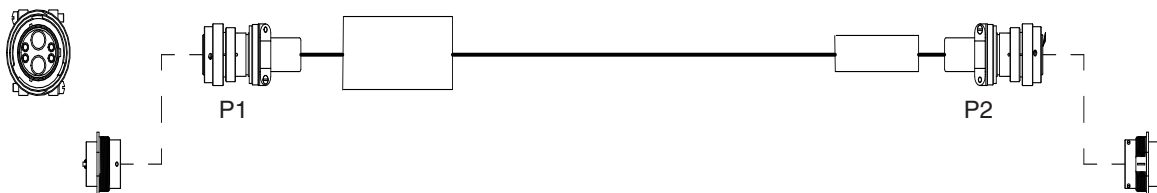

P/N A25032				
Signal	Wire Gauge	Color	From	To
12V PWR	6	RED	P1-3	P2-3
GND	6	BLACK	P1-4	P2-4

Bulk Fill Scale CAN Harness

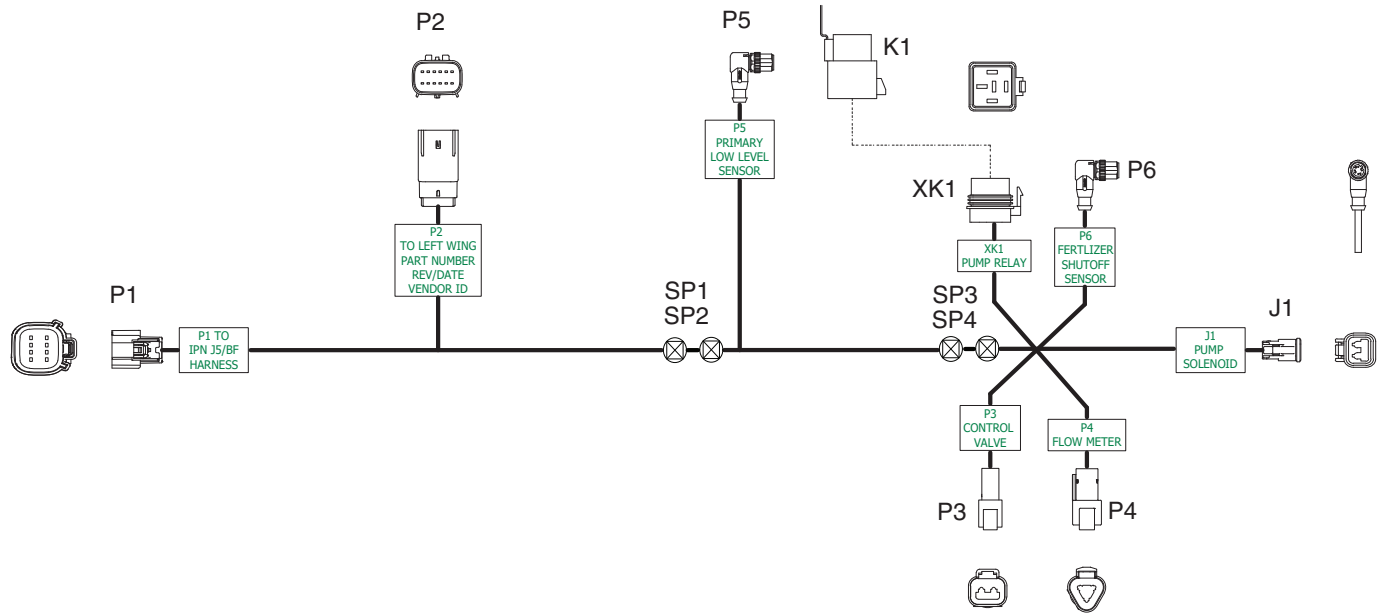

P/N A25712				
Signal	Wire Gauge	Color	From	To
FERTILIZER RATE INCREASE	18	YELLOW	P1-1	P3-1
FERTILIZER RATE DECREASE	18	ORANGE	P1-2	P3-2
FERT PUMP SOLENOID (12V)	16	RED	P2-1	XK1-30
FERT PUMP SOLENOID (12V)	16	RED	XK1-87	J1-1
FERT PUMP SOLENOID (GND)	16	BLACK	P2-2	SP3
FERT PUMP SHUTOFF (SIG)	18	BLUE	P2-3	SP4
FERT PUMP FLOW METER (FREQ)	18	WHITE	P2-5	P4-B
FERT PRIMARY TANK LOW LEVEL (SIG)	18	YELLOW	P2-6	P5-4
FERT LOW LEVEL/PUMP SHUTOFF (GND)	18	BLACK	P2-7	SP2
FERT LOW LEVEL/PUMP SHUTOFF (PWR)	18	RED	P2-8	SP1
FERT PUMP FLOW METER (GND)	18	BLACK	P2-9	P4-C
FERT PUMP FLOW METER (PWR)	18	ORANGE	P2-10	P4-A
FERT PUMP SOLENOID (GND)	16	BLACK	SP3	J1-2
FERT PUMP SOLENOID (GND)	18	BLACK	SP3	XK1-85
FERT PUMP SHUTOFF (SIG)	18	BLUE	SP4	P6-4
FERT PUMP SHUTOFF (SIG)	18	BLUE	SP4	XK1-86
FERT LOW LEVEL/PUMP SHUTOFF (GND)	18	BLACK	SP2	P5-3
FERT LOW LEVEL/PUMP SHUTOFF (GND)	18	BLACK	SP2	P6-3
FERT LOW LEVEL/PUMP SHUTOFF (PWR)	18	RED	SP1	P5-1
FERT LOW LEVEL/PUMP SHUTOFF (PWR)	18	RED	SP1	P6-1

Fertilizer Flow Center Harness

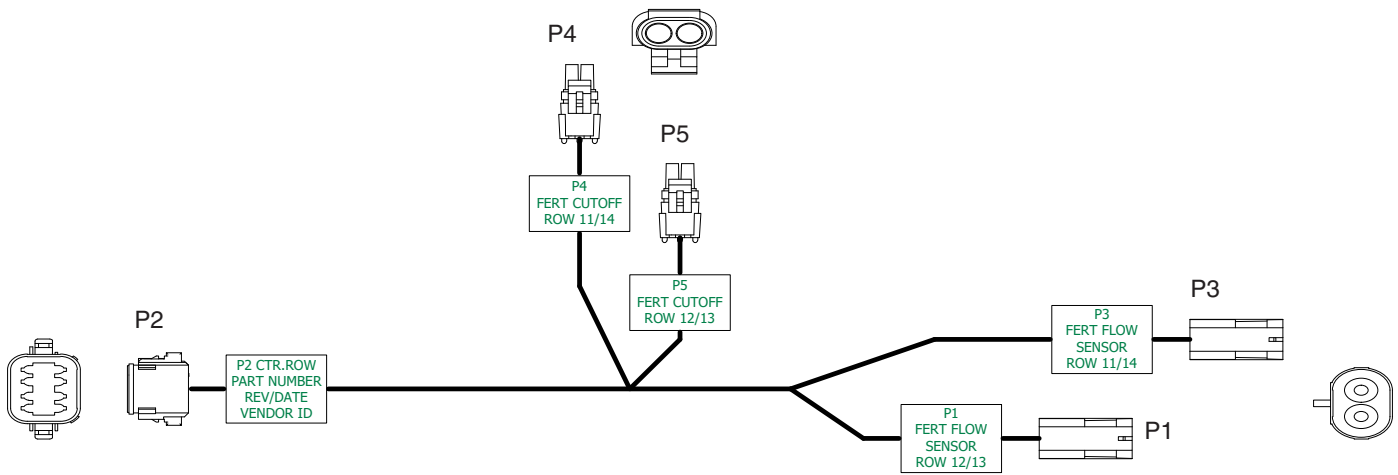

P/N A25713				
Signal	Wire Gauge	Color	From	To
FERT ROW CUTOFF VALVE (PWR)	18	RED	P2-1	P4-A
FERT ROW CUTOFF VALVE (GND)	18	BLACK	P2-8	P4-B
FERT FLOW SENSOR (PWR/SIGNAL)	18	RED	P2-2	P3-A
FERT FLOW SENSOR (GND)	18	BLACK	P2-7	P3-B
FERT ROW CUTOFF VALVE (PWR)	18	RED	P2-3	P5-A
FERT ROW CUTOFF VALVE (GND)	18	BLACK	P2-6	P5-B
FERT FLOW SENSOR (PWR/SIGNAL)	18	RED	P2-4	P1-A
FERT FLOW SENSOR (GND)	18	BLACK	P2-5	P1-B

Fertilizer Flow Harness

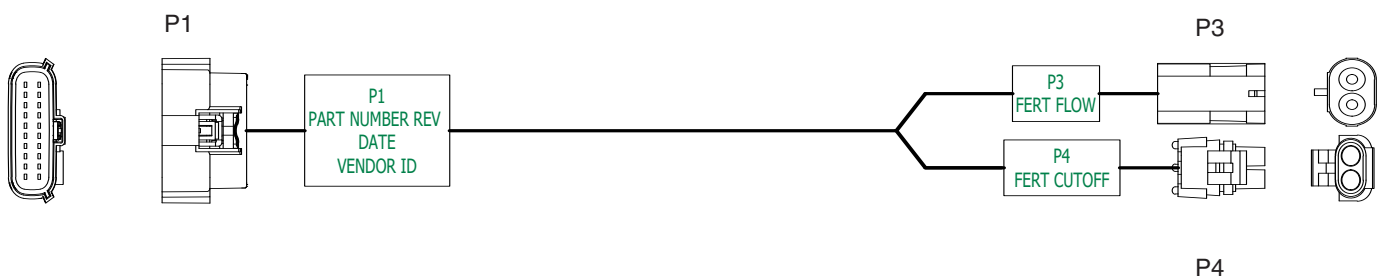

P/N A26332				
Signal	Wire Gauge	Color	From	To
FERT ROW CUTOFF VALVE (PWR)	18	RED	P1-3	P4-A
FERT ROW CUTOFF VALVE (GND)	18	BLACK	P1-4	P4-B
FERT FLOW SENSOR (PWR/SIGNAL)	18	RED	P1-13	P3-A
FERT FLOW SENSOR (GND)	18	BLACK	P1-19	P3-B

Fertilizer Flow Stub Wing Harness

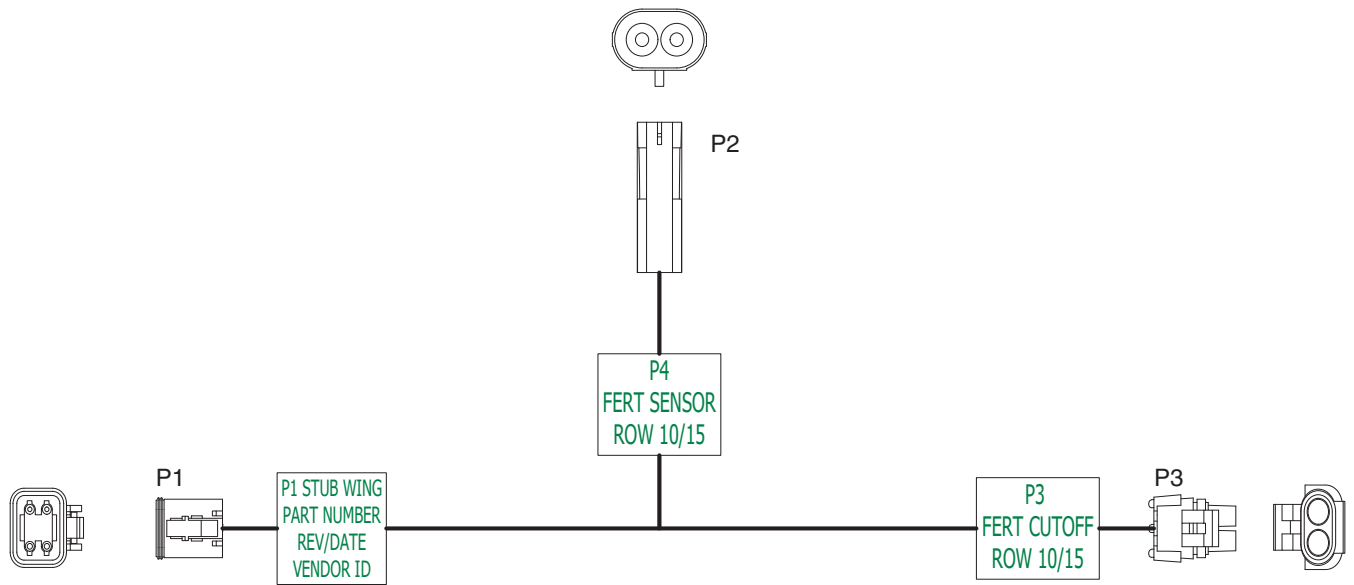

P/N A25714				
Signal	Wire Gauge	Color	From	To
FERT ROW CUTOFF VALVE (PWR)	18	RED	P1-1	P3-A
FERT ROW CUTOFF VALVE (GND)	18	BLACK	P1-2	P3-B
FERT FLOW SENSOR (PWR/SIGNAL)	18	RED	P1-3	P2-A
FERT FLOW SENSOR (GND)	18	BLACK	P1-4	P2-B

Harness Extension Cable

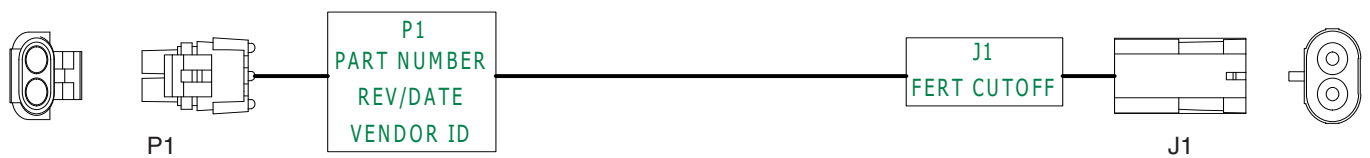

P/N A25814				
Signal	Wire Gauge	Color	From	To
FERT ROW CUTOFF VALVE (PWR)	18	RED	P1-A	J1-A
FERT ROW CUTOFF VALVE (GND)	18	BLACK	P1-B	J1-B

This page intentionally left blank.

BULK FILL

PROBLEM	POSSIBLE CAUSE	SOLUTION
Seed does not travel through delivery tubes.	System pressure set too low.	Increase system pressure.
Seed stops flowing to row unit during planting.	Seed surging.	Shut down air seed delivery system and restart system from idle; seed should start flowing.
	Debris in system.	Insert shutoff door, open cleanout door. remove plug.
Seed does not move from entrainer at startup after exposure to water.	Seed swelled in entrainer.	Insert shutoff door, open cleanout door. remove swelled seed.
Seed bridging in entrainer.	System pressure too high.	Decrease system pressure to recommended pressures: <ul style="list-style-type: none"> • Corn - 12" (~30 cm) of water • Soybean - 10" (~25 cm) of water <p>NOTE: Actual pressure needed is affected by seed size, shape and coating.</p>

CLOSING WHEEL

PROBLEM	POSSIBLE CAUSE	SOLUTION
Closing wheel(s) leave severe imprint in soil.	Too much closing wheel down pressure.	Adjust closing wheel pressure.
Closing wheel(s) not firming soil around seed.	Not enough closing wheel down pressure.	Adjust closing wheel pressure. Severe no till conditions may require use of cast iron closing wheels.
"V" closing wheel running on top of seed furrow.	Improper centering.	Align. See "V" Closing Wheel Adjustment (Rubber or Cast Iron)" on page 3-1.
Single closing wheel not directly over seed.	Improper centering.	Align. See "Covering Disc Adjustments" on page 3-2

PISTON PUMP

PROBLEM	POSSIBLE CAUSE	SOLUTION
Pump hard or impossible to prime.	Valves fouled or in wrong place.	Inspect and clean valves.
	Air leak in suction line.	Repair leak.
	Pump set too low.	Adjust pump setting.
	Packing washers worn out.	Replace.
Low metering.	Valves fouled or in wrong place.	Inspect and clean valves.
	Air leak in suction line.	Repair leak.
	Pump set too low.	Adjust pump setting.
	Broken valve spring.	Replace spring.
Over meters.	Broken discharge valve spring.	Replace spring.
	Trash under valves.	Inspect and clean valves.
	Improper rate setting.	Adjust pump setting.
Leaks through when stopped.	Broken discharge valve spring.	Replace spring.
	Trash under valves.	Inspect and clean valves.
Fertilizer solution leaking under stuffing box.	Packing washers worn out.	Replace.
Pump using excessive oil.	Oil seals or O-ring worn and leaking.	Replace.
Pump operates noisily.	Crankcase components worn excessively.	Inspect and replace if necessary.

ROW MARKER OPERATION

PROBLEM	POSSIBLE CAUSE	SOLUTION
Right marker lowering slower than left marker.	Solenoid valve cartridge in port V1 not opening completely.	Switch with cartridge in port V2. If problem repeats, replace cartridge.
	Hose pinched or collapsed.	Inspect hose routing. Replace or repair hoses as required.
Left marker lowering slower than right marker.	Solenoid valve cartridge in port V2 not opening completely.	Switch with cartridge in port V1. If problem repeats, replace cartridge.
	Hose pinched or collapsed.	Inspect hose routing. Replace or repair hoses as required.
Both markers lowering.	Solenoid valve cartridge stuck open. If left marker switch is selected, right cartridge (V1) is defective. If right marker switch is selected, left cartridge (V2) is defective.	Replace solenoid valve cartridge.
Neither marker lowers.	Blown fuse.	Check red light on control console. It should be on if switch is on. If light is not on, switch to opposite marker position. If light comes on, switch may be defective. Replace switch. Otherwise replace fuse.
	Coils at V1 and V2 not energized.	Poor ground on wire, bad wire connection or damaged wire. Repair as required.
	Marker flow control valve closed too far.	See "Row Marker Speed Adjustment" on page 2-35.
Neither marker will raise.	Marker flow control valve closed too far.	See "Row Marker Speed Adjustment" on page 2-35.
Right marker will not lower.	Solenoid coil in port V1 not energized.	Check switch on control console. Replace if defective. Check coil ground wire. Check for poor connection or damaged wire.
	Solenoid cartridge in port V1 stuck closed.	Switch cartridge with one on the planter you know is operating properly. If right marker lowers, replace defective cartridge.
Left marker will not lower.	Solenoid coil in port V2 not energized.	Check switch on control console. Replace if defective. Check coil ground wire. Check for poor connection or damaged wire.
	Solenoid cartridge in port V2 stuck closed.	Switch cartridge with one on the planter you know is operating properly. If left marker lowers, replace defective cartridge.
Markers traveling too fast and damaging rubber stop on transport stands and/or damaging pivot at rod end of marker cylinders.	Adjust row marker flow control valve.	See "Row Marker Speed Adjustment" on page 2-35.

VACUUM SEED METER

PROBLEM	POSSIBLE CAUSE	SOLUTION
Low seed count.	Meter RPM too high.	Reduce planting rate or planting speed.
	Singulator blade setting too aggressive.	Adjust singulator blade.
	Vacuum level too low.	Increase fan speed.
	Seed sensor not picking up all seeds dropped.	Clean seed tube. Move meter to different row.
	Seeds sticking to seed disc.	Use graphite or talc to aid release.
	Seed treatment buildup in seed disc recesses.	Reduce amount of treatment used and or mix thoroughly. Add talc.
	Seed size too large for disc used.	Use appropriate disc for seed size.
	Wrong seed disc.	Use appropriate disc for seed type and size.
	Failed/worn drive components.	Inspect and replace parts as required.
	Plugged orifices in seed disc.	Inspect and clean disc. Check remnant ejector.
	Loss of vacuum at meter.	Check for foreign material between vacuum cover and disc. Inspect parts for wear/damage. Clean or replace as required.
	Seed bridging in hopper.	Add graphite to improve seed flow.
	Faulty vacuum gauge reading.	Repair/replace gauge.
	Dirt in vacuum manifold.	Check vacuum manifold for dirt and clean.
	Seed baffle (If applicable) not allowing seed flow due to bridging of seed.	Mix talc thoroughly to coat all seeds. Remove seed baffle. See "Row Unit Operation" on page 3-1 for more information.
	Seed disc worn.	Replace.
Vacuum seal worn.	Replace.	
Not planting seed.	Seed hoppers empty.	Fill seed hopper.
	Seed tube plugged/damaged.	Clean or replace tube.
	Meter drive damaged.	Repair/replace drive components.
	Low/no vacuum.	Inspect vacuum system and repair as necessary.
	Singulator blade setting too aggressive.	Adjust singulator blade.
	Faulty vacuum gauge.	Repair/replace vacuum gauge.
	Seed bridging in hopper.	Add graphite to improve seed flow.
	Loss of vacuum at meter.	Check for foreign material between vacuum cover and disc. Inspect parts for wear/ damage. Clean and/or replace as required.
	Wrong seed disc.	Use appropriate disc for seed type and size.
	Meter drive clutch not engaged.	Engage drive clutch.
	Fan not running.	Start fan.
Dirt in vacuum manifold.	Check vacuum manifold for dirt and clean.	

Continued on next page.

VACUUM SEED METER - Continued

PROBLEM	POSSIBLE CAUSE	SOLUTION
Not planting seed. (Continued)	Seed baffle (if applicable) not allowing seed flow due to bridging of seed.	Mix talc thoroughly to coat all seeds. Remove seed baffle. Row Unit Operation section.
	High vacuum.	Adjust vacuum level to appropriate level.
	Wrong seed disc.	Replace seed disc.
	Singulator setting not aggressive enough.	Adjust singulator.
	Faulty vacuum gauge.	Check gauge line for dirt/obstruction. Repair/replace vacuum gauge.
Poor seed spacing.	Obstruction in seed tube.	Clean seed tube.
	Dirty/damaged seed disc.	Inspect seed disc for damage, foreign material in orifices or seed treatment buildup in recesses. Clean or replace.
	Wrong vacuum setting.	Adjust vacuum to appropriate level.
	Excess foreign material in seed.	Inspect and clean meter and seed discs. Use clean, undamaged seed.
	Incorrect singulator setting.	Adjust singulator to appropriate setting.
	Inconsistent driveline.	Inspect drive components for rust, misalignment, worn or damaged parts. Replace/repair as required.
	Toolbar not level or wrong height.	Adjust hitch to level toolbar and row units.
	Planting too fast for conditions.	Reduce speed.
	Rough field conditions.	Reduce speed.
Irregular seed population.	Driving too fast.	Reduce speed.
Unable to achieve desired vacuum level.	Tractor hydraulic flow set too low.	Increase flow to fan motor.
	Incorrect hydraulic connections.	Check all hydraulic connections and hose routings.
	Damaged fan components.	Inspect motor and impeller for wear/damage and repair/replace as necessary.
	Vacuum hose pinched/kinked/blocked.	Inspect air lines for any damage or obstruction. Clean air lines and manifold by removing end cap from manifold and running fan at high speed.
	Vacuum hose loose/disconnected.	Inspect and reattach all air hoses.
	Tractor not producing required hydraulic flow/pressure.	Have tractor serviced by qualified technician.
	Dirt in vacuum gauge line.	Check gauge line for dirt/obstruction and clean.

SOLENOID VALVE

PROBLEM	POSSIBLE CAUSE	SOLUTION
No solenoids operate.	Low voltage.	Must be connected to 12 VDC only. Negative ground.
	Blown fuse.	Replace control console fuse with AGC-15 amp.
	Battery connection.	Clean and tighten.
	Wiring harness damaged.	Repair or replace.
One solenoid valve will not operate.	Bad switch.	Replace on control panel.
	Cut wire in harness.	Locate and repair.
	Bad coil.	Replace.
	Poor connection at coil.	Check.
Valve operating when not energized.	Valve stem stuck open.	Replace cartridge.
	O-ring leaking.	Install new O-ring kit.
	Foreign material under poppet.	Remove and clean cartridge.

PTO PUMP DRIVE AND OIL COOLER OPTION

PROBLEM	POSSIBLE CAUSE	SOLUTION
Pump is squealing.	Lack of oil to pump.	Check for plugged suction strainer. Check oil level.
Oil temperature high.	Low oil level.	Check oil level and add as required.
Desired fan speed cannot be achieved.	Low oil level.	Check oil level and add as required.
	Plugged filter.	Check and change as required.