

MODEL 3705 FRONT FOLD EXPORT PLANTER OPERATOR'S MANUAL

M0313-01

Rev. 10/21

This manual is applicable to: Model 3705 Front Folding Planters
24 Row 70 cm; 2021 Production and on

Record the model number and serial number of your planter along with date purchased:

Model Number _____ 3705 _____

Serial Number _____

Date Purchased _____

Monitor Serial Number _____

Measured Pulses Per Mile/Km (Radar Distance Sensor) _____

Measured Pulses Per Mile/Km (Magnetic Distance Sensor) _____

SERIAL NUMBER

The serial number plate is located on the planter frame as shown below. The serial number provides important information about your planter and is needed to obtain correct replacement parts. Always provide model number and serial number to your Kinze Dealer when ordering parts or when contacting Kinze Manufacturing, Inc.

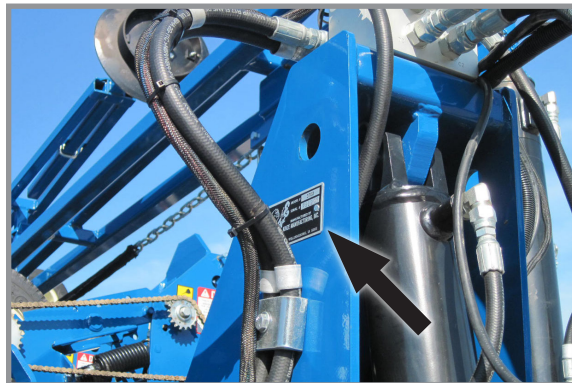

Serial number plate location



EUROPEAN DECLARATION OF CONFORMITY

Kinze Manufacturing
2172 M Avenue
Williamsburg, IA 53261

Kinze Europe UAB
Guopstu k., Senuju Traku sen
LT-21148 Traku r., Lithuania

We, Kinze Manufacturing and Kinze Europe UAB declare, under our sole responsibility, the following products – agricultural planter models 3005, 3035, 3115, 3145, 3205, 3505, 3605, 3665, 3705, 4805, and 4905 – to which this declaration relates, are in conformity with the applicable provisions of the following standards, other normative documents and Directives, as appropriate by version and model:

2006/42/EC; EN 1037:1995+A1:2008; EN ISO 13850:2008; EN ISO 13857:2008; EN 349:1993+A1:2008; EN 547-1:1996+A1:2008; EN 547-2:1996+A1:2008; EN 547-3:1996+A1:2008; EN ISO 13732-1:2008; EN 614-1:2006+A1:2009; EN 614-2:2000+A1:2008; EN 953:1997+A1:2009; EN ISO 13849-1:2008; EN ISO 13849-2:2012; EN ISO 4254-1; EN ISO 12100:2010; EN ISO 4413:2010.

The Technical Construction File is maintained at: Kinze Manufacturing, Inc., 2172 M Avenue, Williamsburg, Iowa, USA, 52361-0806.

The authorized representative located within the community is: Edvardas Melys, Kinze Europe UAB, Guopstu k., Senuju Traku sen, LT-21148 Traku r., Lithuania.

Place of Issue: Kinze Manufacturing Inc., Williamsburg, Iowa, USA.

Date of Issue: 20200821 | August 21, 2020

Signed on behalf of Kinze Manufacturing Inc. and Kinze Europe UAB:

Jay D. Grimes

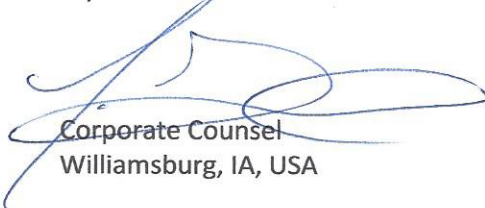

Corporate Counsel
Williamsburg, IA, USA



Kinze Manufacturing, Inc.



СЕРТИФИКАТ СООТВЕТСТВИЯ

№ ЕАЭС RU C-US.АД07.В.02342/20

Серия **RU** № **0225035**

ОРГАН ПО СЕРТИФИКАЦИИ Орган по сертификации Общество с ограниченной ответственностью «Центр Сертификации «ВЕЛЕС». Место нахождения (адрес юридического лица): 195009, РОССИЯ, город Санкт-Петербург, улица Академика Лебедева, дом 12, корпус 2, литера А, этаж 2, комната 26. Адрес места осуществления деятельности: 190068, РОССИЯ, город Санкт-Петербург, переулок Никольский, дом 4 литер А, помещение 8Н. Уникальный номер записи об аккредитации в реестре аккредитованных лиц № RA.RU.10АД07. Дата решения об аккредитации: 24.03.2016. Телефон: +74952211810 Адрес электронной почты: info@velessert.ru

ЗАЯВИТЕЛЬ ОБЩЕСТВО С ОГРАНИЧЕННОЙ ОТВЕТСТВЕННОСТЬЮ "МИР ТЕХНОЛОГИЙ"
Место нахождения (адрес юридического лица) и адрес места осуществления деятельности: 117042, Россия, город Москва, улица Адмирала Руднева, дом 4, этаж 6, помещение IV, офис 613
Основной государственный регистрационный номер 1187746469096.
Телефон: 89154152183. Адрес электронной почты: MirTekhnology@gmail.com

ИЗГОТОВИТЕЛЬ KINZE Manufacturing, Inc.
Место нахождения (адрес юридического лица): Соединенные Штаты, 2172 M Avenue, Williamsburg, IA 52631-0806
Филиал изготовителя: KINZE Europe, UAB Литва, Guopstu kelias 17, Guopstos, LT-21148 Traku rajonas

ПРОДУКЦИЯ Машины сельскохозяйственные: сеялка точного высева торговой марки KINZE, моделей: 3000, 3005, 3030, 3035, 3110, 3115, 3140, 3145, 3200, 3205, 3500, 3505, 3600, 3605, 3660, 3665, 3700, 3705, 4700, 4705, 4800, 4805, 4900, 4905.
Продукция изготовлена в соответствии с Директивой 2006/42/ЕС «Машины и механизмы».

Серийный выпуск

КОД ТН ВЭД ЕАЭС 8432311100

СООТВЕТСТВУЕТ ТРЕБОВАНИЯМ

Технического регламента Таможенного союза "О безопасности машин и оборудования" (ТР ТС 010/2011)

СЕРТИФИКАТ СООТВЕТСТВИЯ ВЫДАН НА ОСНОВАНИИ протокола испытаний № 1023/3АТС-2020 от 27.10.2020 года, выданного Испытательной лабораторией «АвтоТракторные Средства» Общество с ограниченной ответственностью «ПРОММАШ ТЕСТ» (регистрационный номер аттестата аккредитации RA.RU.21НА71) акта анализа состояния производства от 21.09.2020 года, выданного Органом по сертификации Общество с ограниченной ответственностью «Центр Сертификации «ВЕЛЕС» обоснования безопасности; руководства по эксплуатации; паспорта

Схема сертификации: 1с

ДОПОЛНИТЕЛЬНАЯ ИНФОРМАЦИЯ ГОСТ Р 53489-2009 "Система стандартов безопасности труда. Машины сельскохозяйственные навесные и прицепные. Общие требования безопасности" разделы 4 и 5. Срок службы, срок и условия хранения указаны в эксплуатационной документации, приложенной к изделию.

СРОК ДЕЙСТВИЯ С 28.10.2020 **ПО** 27.10.2025
ВКЛЮЧИТЕЛЬНО

Руководитель (уполномоченное лицо) органа по сертификации

Эксперт (эксперт-аудитор) (эксперты (эксперты-аудиторы))



 Родзина Галина Александровна (Ф.И.О.)
 Киренко Константин Борисович (Ф.И.О.)

TO THE DEALER

Predelivery service includes assembly, lubrication, adjustment and test. This service helps ensure planter is delivered to retail customer/end user ready for field use.

PREDELIVERY CHECKLIST

Use the following checklist after planter is completely assembled. Check off each item as it is found satisfactory or after proper adjustment is made.

- Row units properly spaced and optional attachments correctly assembled.
- Row marker assemblies installed and adjusted at each end of the planter.
- Vacuum and bulk fill components properly installed (as applicable).
- All grease fittings in place and lubricated.
- All working parts move freely, bolts are tight, and cotter pins are spread.
- Check all drive chains for proper tension and alignment.
- Check for oil leaks and proper hydraulic operation.
- Hydraulic hoses correctly routed to prevent damage.
- Inflate tires to specified air pressure and torque wheel lug bolts and lug nuts as specified in the Operator Manual.
- All safety decals correctly located and legible. Replace if damaged.
- All reflective decals and SMV sign correctly located and visible when the planter is in transport position.
- Safety/warning lights correctly installed and working properly.
- Paint all parts scratched during shipment or assembly.
- All safety lockup devices on the planter and correctly located.
- Auxiliary safety chain properly installed and hardware torqued to specification.
- Vacuum fan PTO-driven pump correctly attached to tractor. Oil reservoir filled to capacity and system inspected for leaks (If applicable).
- Control box properly installed in tractor. All cables correctly routed and secure.

Planter has been thoroughly checked and to the best of my knowledge is ready for delivery to the customer.

(Signature of Set-Up Person/Dealer Name/Date)

OWNER REGISTER

Name _____ Delivery Date _____

Street Address _____ Model No. 3705 Serial No. _____

City, State/Province _____ Dealer Name _____

ZIP/Postal Code _____ Dealer No. _____

DELIVERY CHECKLIST

Use the following checklist at time planter is delivered as a reminder of very important information which should be conveyed to retail customer/end user. Check off each item as it is fully explained.

- Check proper operation of vacuum fan, bulk fill fan, and PTO-driven pump (If applicable) with tractor used with planter.
- Life expectancy of this or any other machine is dependent on regular lubrication as directed in the Operator Manual.
- All applicable safety precautions.
- Along with retail customer/end user, check reflective decals and SMV sign are clearly visible with planter in transport position and attached to tractor. Check safety/warning lights are in working condition. Tell retail customer/end user to check federal, state/provincial, and local regulations before towing or transporting on a road or highway.
- Give Operator Manual, Parts Manual, and all Instruction Sheets to retail customer/end user and explain all operating adjustments.
- Read warranty to retail customer/end user.
- Complete Warranty and Delivery Report form.

To the best of my knowledge this machine has been delivered ready for field use and customer has been fully informed as to proper care and operation.

(Signature of Delivery Person/Dealer Name/Date)

AFTER DELIVERY CHECKLIST

The following is a list of items we suggest to check during the first season of use of the equipment.

- Check planter performance with retail customer/end user.
- Check performance of vacuum seed metering system with retail customer/end user.
- Review importance of proper maintenance and adherence to all safety precautions with retail customer/end user.
- Check for parts that may need to be adjusted or replaced.
- Check all safety decals, reflective decals, and SMV sign are correctly located as shown in the Parts Manual and that decals are legible. Replace if damaged or missing.
- Check safety/warning lights are working properly.

(Signature of Follow-Up Person/Dealer Name/Date)

**All registrations must be submitted online at "business.kinze.com" within 5 business days of delivery.
Retain a copy of this form for auditing purposes.**

Tear Along Perforation

OVERVIEW

To The Owner	1-1
Warranty	1-3
General Information	1-4
Specifications	1-5
General Safety Rules	1-6
Safety Precautions	1-7
Safety Instructions, Signs, and Decals	1-9

MACHINE OPERATION

Planter Lift Safety Lockup	2-1
Row Marker Safety Lockup	2-1
Hitch Parallel Linkage Lockup	2-2
2-Speed Jack Assembly	2-2
Initial Planter Preparation	2-3
Tractor Preparation and Hookup	2-5
Transporting Planter	2-8
Cylinder Information	2-9
Hydraulic Hose Information	2-10
Level Planter	2-15
Contact Wheel Spring Adjustment	2-15
Contact Wheel Drive Sprockets	2-16
Seed Rate Transmission Adjustment	2-16
Wrap Spring Wrench Operation	2-17
Shear Protection	2-17
Sliding Hitch Linkage	2-18
PTO Pump Initial Startup	2-18
Hydraulic/Electric Operation	2-19
Transport to Field Sequence	2-20
Field Operation	2-24
Field to Transport Sequence	2-25
Row Marker Operation	2-29
Row Marker Speed Adjustment	2-30
Row Marker Chain Adjustment	2-31
Row Marker Length And Disc Blade Adjustment	2-32
Vacuum System	2-33
Vacuum Fan Valve Block Assembly	2-33
Analog Vacuum or Pressure Gauge	2-33
Ag Leader Integra Display	2-34
Ag Leader Monitoring Control Package (PMM)	2-34
Ag Leader InCommand 1200 Display	2-34
Point Row Clutches	2-35
Piston Pump	2-36
Check Valves	2-37
Low-Rate (Pop-Up) Liquid Fertilizer System	2-37
Rear Trailer Hitch (24 Row 70 CM Only)	2-37

Field Test	2-38
Field Check Seed Population	2-38
Determining Liters Per Hectare	2-39
Field Check Granular Chemical Application	2-40
Water Tank	2-41

ROW UNIT OPERATION

Planting Depth	3-1
“V” Closing Wheel Adjustment (Rubber or Cast Iron)	3-1
Closing Wheel Shield (Rubber or Cast Iron “V” Closing Wheels)	3-1
Drag Closing Attachment	3-2
Row Unit Extension Brackets	3-2
Seed Hoppers	3-3
Seed Meter Drive Release	3-3
Row Unit Chain Routing	3-4
Quick Adjustable Down Force Springs Option	3-5
Pneumatic Down Pressure (PDP)	3-6
Vacuum Settings	3-8
Seed Meter Cleanout	3-11
Additives	3-12
Row Unit Mounted Residue Wheel	3-13
Spiked Closing Wheel	3-14
Row Unit Mounted No Till Coulter	3-15
Coulter Mounted Residue Wheels	3-15
Granular Chemical Hopper and Drive	3-16
Granular Chemical Banding Options	3-17
Granular Chemical Bander Shield	3-17

RATE CHARTS 4-1**LUBRICATION AND MAINTENANCE**

Lubrication	5-1
Sealed Bearings	5-1
Wheel Bearings	5-1
Drive Chains	5-2
Bushings	5-4
Sliding Hitch Linkage	5-4
PTO Shaft Coupling	5-5
Wrap Spring Wrench Assembly	5-5
Liquid Fertilizer Piston Pump Crankcase Oil Level	5-5
Grease Fittings	5-6
Mounting Bolts and Hardware	5-10
Tire Pressure	5-11
Vacuum Seed Meter Maintenance	5-13
Seed Meter Cleanout	5-13
Gauge Wheel Adjustment	5-14

Gauge Wheel Arm Pivot Spindle Replacement 5-14

Gauge Wheel Arm Bushing/Seal Replacement 5-15

15" Seed Opener Disc Blade/Bearing Assembly 5-16

Seed Tube Guard/Inner Scraper 5-18

Row Unit Mounted Disc Furrower 5-19

Granular Chemical Attachment 5-19

Spiked Closing Wheel 5-19

Row Unit Mounted No Till Coulter 5-20

Coulter or Row Unit Mounted Residue Wheels 5-20

Point Row Clutch Maintenance 5-21

Wrap Spring Wrench Cleaning and repair 5-21

Planter Mounted Pump Drive and Oil Cooler 5-23

Digital Vacuum Gauge Adjustment 5-23

Check Valve 5-24

Detent Lever Valve 5-24

Flow Control Valves 5-24

Pressure Relief Valves 5-24

Relief Valve Cartridge 5-24

Solenoid Valve 5-25

Stroke Limiter Valve 5-25

Chain Tension Adjustment 5-25

Stroke Limiter (Height Stop) Valve Adjustment 5-26

Detent Lever (Lowering Control) Valve Adjustment 5-27

Row Marker Bearing Lubrication or Replacement 5-28

Lift/Ground Drive Wheel Bearing Repack
or Replacement 5-29

Transport Wheel Bearing Replacement 5-30

Fertilizer Check Valve Cleaning and Repair 5-31

Low-Rate Liquid Fertilizer System 5-31

Pneumatic Down Pressure Air Compressor Tank 5-31

Preparation for Storage 5-32

Piston Pump Storage 5-33

Electrical Wiring Diagram for Lighting Package 5-34

Electrical Control Console Schematic 5-35

Electrical Wiring Harness Schematic (on tractor) 5-36

Electrical Wiring Harness Schematic (on planter) 5-37

Valve Block - Located on Hitch 5-38

Valve Blocks - Located on Tower and R.H. Wing 5-39

Electrical Wiring Harness Schematic
(Vacuum Fan Control) 5-40

Hydraulic Hose Life 5-41

Hydraulic Schematic
(Vacuum Fan System) 24 Row 70 cm 5-42

Hydraulic System Schematic (24 Row 70 cm) 5-44

Hydraulic Valve Block Locations 5-46

Hydraulic Valve Block Functions 5-47

TROUBLESHOOTING

Closing Wheel 6-1

Lift Circuit 6-1

Piston Pump 6-1

Stroke Limiter Valve 6-2

Solenoid Valve 6-2

PTO Pump Drive and Oil Cooler Option 6-2

Row Marker Operation 6-4





Vacuum Seed Meter 6-5

Kinze Manufacturing, Inc. thanks you for your patronage. We appreciate your confidence in Kinze farm machinery. Your Kinze planter has been carefully designed to provide dependable operation in return for your investment.

This manual has been prepared to aid you in the operation and maintenance of the planter. It should be considered a permanent part of the machine and remain with the machine when you sell it.

It is the responsibility of the user to read and understand the Operator Manual in regards to safety, operation, lubrication and maintenance before operation of this equipment. It is the user's responsibility to inspect and service the machine routinely as directed in the Operator Manual. We have attempted to cover all areas of safety, operation, lubrication and maintenance; however, there may be times when special care must be taken to fit your conditions.

Throughout this manual the symbol  and the words **DANGER**, **WARNING**, and **CAUTION** are used to call attention to safety information that if not followed, will or could result in death or injury. **NOTICE** and **NOTE** are used to call your attention to important information. The definition of each of these terms follows:

	Indicates an imminently hazardous situation that, if not avoided, will result in death or serious injury. This signal word is to be limited to the most extreme situations, typically for machine components which, for functional purposes, cannot be guarded.
	Indicates a potentially hazardous situation that, if not avoided, could result in death or serious injury, and includes hazards that are exposed when guards are removed. It may also be used to alert against unsafe practices.
	Indicates a potentially hazardous situation that, if not avoided, may result in minor or moderate injury. It may also be used to alert against unsafe practices.
	Used to address safety practices not related to personal injury.

NOTE: Special point of information or machine adjustment instructions.

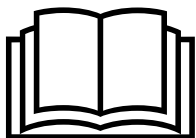
**WARNING**

Improperly operating or working on this equipment could result in death or serious injury. Read and follow all instructions in Operator Manual before operating or working on this equipment.

**WARNING**

Some photos in this manual may show safety covers, shields, or lockup devices removed for visual clarity. **NEVER OPERATOR OR WORK ON** machine without all safety covers, shields, and lockup device in place as required.

NOTE: Some photos in this manual may have been taken of prototype machines. Production machines may vary in appearance.

NOTE: Some photos and illustrations in this manual show optional attachments installed. Contact your Kinze Dealer for purchase of optional attachments.

The Kinze Limited Warranty for your new machine is stated on the retail purchaser's copy of the Warranty And Delivery Receipt form. Additional copies of the Limited Warranty can be obtained through your Kinze Dealer.

Warranty, within the warranty period, is provided as part of Kinze's support program for registered Kinze products which have been operated and maintained as described in this manual. Evidence of equipment abuse or modification beyond original factory specifications will void the warranty. Normal maintenance, service and repair is not covered by Kinze warranty.

To register your Kinze product for warranty, a Warranty And Delivery Receipt form must be completed by the Kinze Dealer and signed by the retail purchaser, with copies to the Dealer, and to the retail purchaser. Registration must be completed and submitted to Kinze Manufacturing, Inc. within 5 business days of delivery of the Kinze product to the retail purchaser. Kinze Manufacturing, Inc. reserves the right to refuse warranty on serial numbered products which have not been properly registered.

If service or replacement of failed parts which are covered by the Limited Warranty are required, it is the user's responsibility to deliver the machine along with the retail purchaser's copy of the Warranty And Delivery Receipt to the Kinze Dealer for service. Kinze warranty does not include cost of travel time, mileage, hauling or labor. Any prior arrangement made between the Dealer and the retail purchaser in which the Dealer agrees to absorb all or part of this expense should be considered a courtesy to the retail purchaser.

Kinze warranty does not include cost of travel time, mileage, hauling, or labor.

The Model 3705 Front Folding Planter is available with vacuum meters, row hoppers, and various options. Contact your Kinze Dealer for additional details.



Model 3705 24 Row Conventional Planter

Information used in this manual was current at time of printing. However, due to Kinze’s ongoing product improvement, production changes may cause your machine to appear slightly different in detail. Kinze Manufacturing, Inc. reserves the right to change specifications or design without notice and without incurring obligation to install the same on machines previously manufactured. To obtain the most recent version of your publication, please contact your Kinze dealer.

Right hand (R.H.) and left hand (L.H.), as used throughout this manual, are determined by facing direction machine travels in use unless otherwise stated.

TOOLS REQUIRED

Hardware Size / Tool Required			
1/4" = 7/16"	7/16" = 5/8" (nut for 7/16" hardware uses 1 1/16" tool)	3/4" = 1 1/8"	1 1/4" = 1 7/8"
5/16" = 1/2"	1/2" = 3/4"	7/8" = 1 5/16"	1 1/2" = 2 1/4"
3/8" = 9/16"	5/8" = 15/16"	1" = 1 1/2"	

Specifications

Specification	24 Row, 70CM
Weight Empty**	18,298-19,996 lb (8300-9070 kg)
Axle Weight Empty*	13,199 lb (5987 kg)
Tongue Weight Empty*	5481 lb (2486 kg)
*Weight based off a typical configuration of a complete machine. **Base machine weight depending on how machine is equipped (markers, PTO, etc.).	
Transport Height	11' 4" (3.50 m)
Planting Length	27' 3" (8.30 m)
Transport Length	32' 2" (9.80 m)
Planting Width	47' 11" (14.60 m)
Transport Width	13' 1" (4.00 m)
	With Granular Chemical Option: 14' 5" (4.40 m)
Seed Capacity	1.75 bu (62 L)/Hopper
Transport Tire Size	(4) 36 x 16-17.5 rib duplex 14-ply tubeless
Wing/Lift Tires	(4) 7.5" x 20", 8-ply, Tubeless Rib Implement
Contact Drive Tires	(4) 4.80" x 8"
Piston Pump Drive Tires (Optional)	(2) 7.60" x 15"
Field Lift	Four Master/Two Slave Hydraulics
Row Markers	Independently controlled, three stage, low profile equipped disk blade depth bands.

Tractor Hydraulic* and Power Requirements**

SCV Requirements	
Lift	1
Fold/Marker	1
Vacuum	2
Number of SCV (w/o PTO):	4
Number of SCV (w/ PTO):	2 (Dual Stage PTO)
Hydraulic Capacity Requirements (l/min)	
Lift & Fold	57
Vacuum	42
Estimated minimum flow (l/min) (w/o PTO):	98
Estimated minimum flow (l/min) (w/ PTO):	57
Tractor Power Requirements (HP)	
Power Requirements (HP)	From 250

*All data above is indicative. The table shown above describes the specific hydraulic demands by planter model and functional area. Planter hydraulic requirements depend on a specific planter configuration.



**Soil type, field tillage, terrain, and planter configuration will affect tractor power requirements.

1. Read and understand instructions provided in this manual and warning labels. Review these instructions frequently!
 2. This machine is designed and built with your safety in mind. Do not make any alterations or changes to this machine. Any alteration to design or construction may create safety hazards.
 3. A large portion of farm accidents happen from fatigue or carelessness. Safe and careful operation of tractor and planter will help prevent accidents.
 4. Never allow planter to be operated by anyone unfamiliar with operation of all functions of the unit. Operators must read and thoroughly understand all instructions given in this manual before operating or working on equipment.
 5. Be aware of bystanders, particularly children! Always look around to make sure it is safe to start tow vehicle engine or move planter. This is particularly important with higher noise levels and quiet cabs, as you may not hear people shouting.
 6. Make sure planter weight does not exceed towing capacity of tractor, or bridge and road limits. This is critical to maintain safe control and prevent death or injury, or property and equipment damage.
 7. Never ride or allow others to ride on planter.
 8. Store planter in an area away from human activity. DO NOT permit children to play on or around the stored unit.
 9. Keep hands, feet, and clothing away from moving parts. Do not wear loose-fitting clothing which may catch in moving parts.
 10. Always wear protective clothing, shoes, gloves, hearing, and eye protection applicable for the situation.
 11. Do not allow anyone to stand between tongue or hitch and towing vehicle when backing up to planter.
 13. Prevent electrocution, other injuries, or property and equipment damage. Watch for obstructions such as wires, tree limbs, etc. when operating machine. Be aware of clearances during turns and when folding/unfolding planter.
 14. Reinstall all guards removed for maintenance activities. Never leave guards off during operation.
 15. Use of aftermarket hydraulic, electric, or PTO drives may create serious safety hazards to you and people nearby. If you install such drives, follow all appropriate safety standards and practices to protect you and others near this planter from injury.
 16. Follow all federal, state/provincial, and local regulations when towing farm equipment on a public highway. Use safety chain (not an elastic or nylon/plastic tow strap) to retain connection between towing and towed machines in the event of primary attaching system separation.
 17. Make sure all safety/warning lights, SMV sign, and reflective decals are in place and working properly before transporting the machine on public roads.
 18. Limit towing speed to 15 MPH (25 km/h). Tow only with farm tractor of a minimum 90 HP. Allow for unit length when making turns.
 19. Reduce speed prior to turns to avoid the risk of overturning. Always drive at a safe speed relative to local conditions and ensure your speed is slow enough for a safe emergency stop.
 20. Chemical application is often an integral part of planting. Follow label instructions for proper chemical mixing, handling and container disposal methods.
 21. Be familiar with safety procedures for immediate first aid should you accidentally contact chemical substances.
 22. Use the proper protective clothing and safety equipment when handling chemicals.
 23. Chemicals are supplied with Material Safety Data Sheets (MSDS) that provide full information about the chemical, its effects on exposure, and first aid needs in the event of an emergency. Keep your MSDS file up-to-date and available for first responders in case of emergency.
 24. When servicing ground engaging components such as opening disks and firming points, use special care to avoid points and edges worn sharp during use.
 25. Use professional help if you are unfamiliar with working on hydraulic systems. Pressurized hydraulic fluid can penetrate body tissue and result in death, serious infection, or other injuries.
- Never pour waste onto the ground, down a drain, or into any water source.
- When disposing of waste such as oil, use leakproof containers. Be sure to use containers that do not resemble food or beverage which may mislead someone into consuming them. Dispose of oil per your local, regional requirements.
- When disposing of any fertilizer chemicals used, contact the supplier of the chemicals.
- Model 3705 planter consists of 85% recyclable metals, 10% recyclable plastic and rubber, and 5% waste.

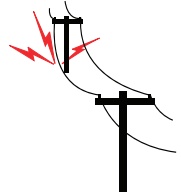
Following are some common hazard warnings associated with this equipment. Pay close attention to all safety, operating, and maintenance information in this manual and decals applied to your equipment.

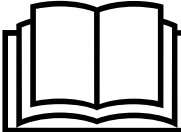
 DANGER	Contacting or coming close to power lines or other high energy sources will cause death or serious injury.
	Keep away from power lines or high energy sources at all times.

 WARNING	Improperly operating or working on this equipment could result in death or serious injury. Read and follow all instructions in Operator Manual before operating or working on this equipment.
	

 WARNING	Falling equipment can cause death or serious injury. Install all lockup devices or lower planter to ground before working on equipment.
	

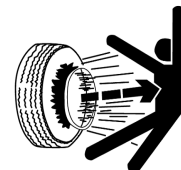
 WARNING	Explosive separation of rim and tire parts can cause death or serious injury. Overinflation, rim and tire servicing, improper use of rims and tires, or worn or improperly maintained tires could result in a tire explosion.
	

SAFETY SIGNS AND DECALS

	<p>All safety/warning lights, reflective decals, and SMV sign must be in place and visible before transporting machine on public roads or death, serious injury, and damage to property and equipment may result. Check federal, state/provincial, and local regulations before transporting equipment on public roads.</p>
---	---



Safety signs and decals are placed on the machine to warn of hazards and provide important operating and maintenance instructions. Information on these signs are for your personal safety and the safety of those around you. FOLLOW ALL SAFETY INSTRUCTIONS!

- Keep signs clean so they can be easily seen. Wash with soap and water or cleaning solution as required.
- Replace safety signs if damaged, painted over, or missing.
- Check reflective decals and SMV sign periodically. Replace if they show any loss of reflective properties.
- When replacing decals, clean machine surface thoroughly with soap and water or cleaning solution to remove all dirt and grease.

NOTE: Safety sign and decal locations are shown in the Parts Manual for this machine.

NOTE: Style and locations of SMV sign, reflective decals, and safety/warning lights conform to ANSI/ASABE S279.14 JUL 2008 and ANSI/ASABE S276.6 JAN 2005.



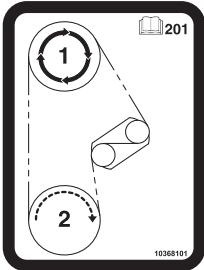
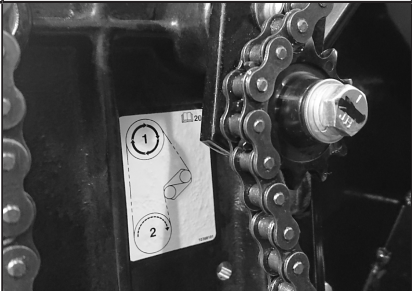
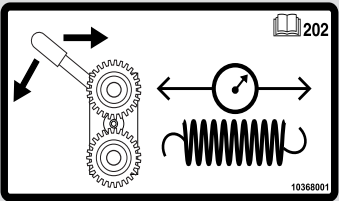
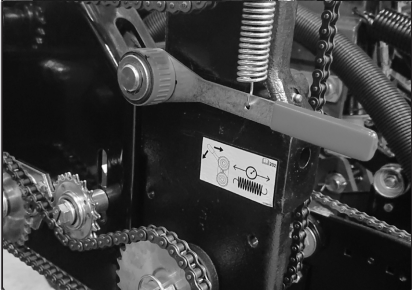
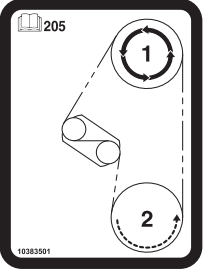
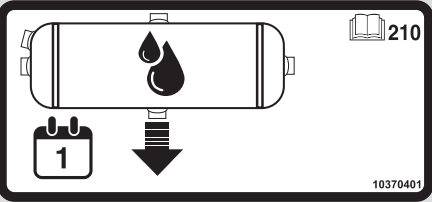
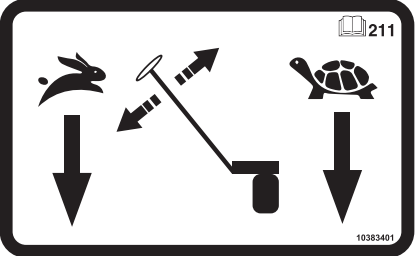

PICTORIAL DECALS

No.	Decal	Placement	Meaning
101			Oil/Grease daily.
102			Oil/Grease weekly.





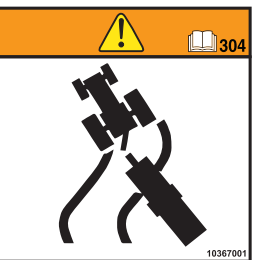



PICTORIAL DECALS

No.	Decal	Placement	Meaning
201			<p>Upper sprocket is the drive sprocket. Lower sprocket is the driven sprocket.</p>
202			<p>Rotate knurled collar on wrap spring tightener to release spring tension.</p>
205		<p>On transmission.</p>	<p>Upper sprocket is the drive sprocket. Lower sprocket is the driven sprocket.</p>
210		<p>On PDP tank.</p>	<p>Drain moisture from air tank daily. Drain tank completely for storage.</p>
211		<p>On hydraulic block cover.</p>	<p>Control the speed at which row markers raise/lower. Tortoise for slower speed, rabbit for faster speed.</p>

PICTORIAL DECALS

No.	Decal	Placement	Meaning
213		On water tank.	Water for emergency rinse.
301		On transport wheel arm.	Overinflation may cause explosive separation of tire and rim, which could result in death or serious injury. Follow inflation specifications and maintenance instructions in the Operator's Manual.
302		On insecticide hopper lids.	Agricultural chemicals can cause death or serious injury to persons, animals, and plants or seriously damage soil, equipment, and property. Read and follow all chemical and equipment manufacturer labels and instructions.
304		On planter hitch.	Loss of control can cause death or serious injury, or damage to property and equipment. Tow only with farm tractor weight rated and configured for this equipment. Use safety chains and transport as specified in the Operator's and Parts Manuals.
306			<p>Uncontrolled machine movement can crush resulting in death, serious injury, or damage to property and equipment.</p> <p>Install safety lockup devices before working under or transporting this equipment.</p>

PICTORIAL DECALS

No.	Decal	Placement	Meaning
307			<p>Removing this wheel and axle assembly can cause equipment to tip over, which could result in death, serious injury, or damage to property and equipment.</p>
308			<p>Improperly operating or working on this equipment could result in death or serious injury. Read and follow all instructions in Operator Manual before operating or working on this equipment.</p>
309		<p>On row markers.</p>	<p>Row marker can lower at any time and could cause death or serious injury.</p> <p>Stay away from row markers!</p> <p>Install safety lockup device when not in use.</p>
310			<p>Uncontrolled movement of planter components can cause death, serious injury, or damage to property and equipment.</p> <p>Raise planter and install cylinder lockups before folding. Fold on level ground. Install wing safety latches before towing.</p>
401		<p>On Vacuum fan.</p>	<p>Fan can start at any time. Operating fan can blow debris and has a high noise level.</p> <p>Always wear eye and hearing protection when working around fan.</p>

PLANTER LIFT SAFETY LOCKUP



Uncontrolled machine movement can crush or cause loss of control resulting in death, serious injury, or damage to property and equipment. Install all safety lockup devices before working under or transporting this equipment.

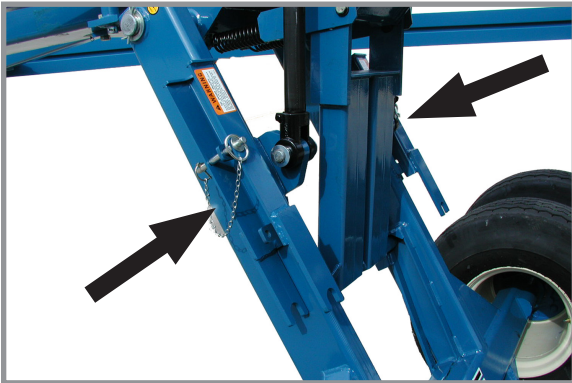

Safety lockup in storage position

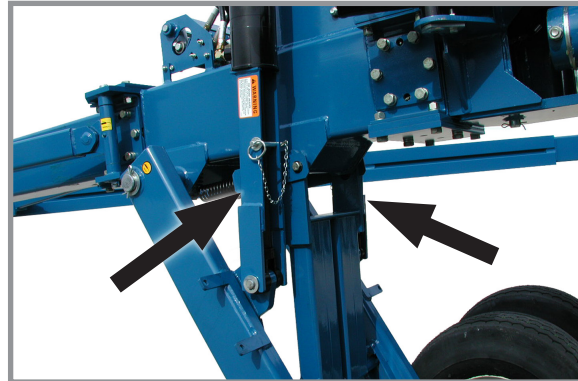

Safety lockup in transport/maintenance position

Planter lift safety lockup is installed between lift cylinder and wheel lift arm. It is held in place by a pin and lynch pin. Remove safety lockup and store on hose take-up for field operation.

ROW MARKER SAFETY LOCKUP



Row marker can lower at any time and could cause death or serious injury. Stay away from row markers! Install safety lockup device when not in use.



Row marker safety lockup stored



Row marker safety lockup installed

Always install row marker lockups when working on, storing, or transporting planter. Hold in place with two clevis pins.

**WARNING**

Planter hitch may raise uncontrollably during folding/unfolding and can cause death, serious injury, or damage property and equipment. **DO NOT** fold or unfold planter without planter attached to a tractor. **DO NOT** unhitch planter from tractor unless fully folded for transport or fully unfolded with planting units lowered to ground.

**WARNING**

Uncontrolled movement of equipment can cause loss of control and could result in death, serious injury, or damage to property and equipment. Install all safety pins before transporting equipment.

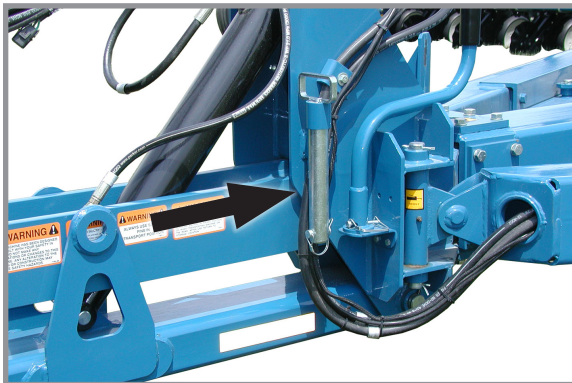
HITCH PARALLEL LINKAGE LOCKUP

Hitch parallel linkage pin stored

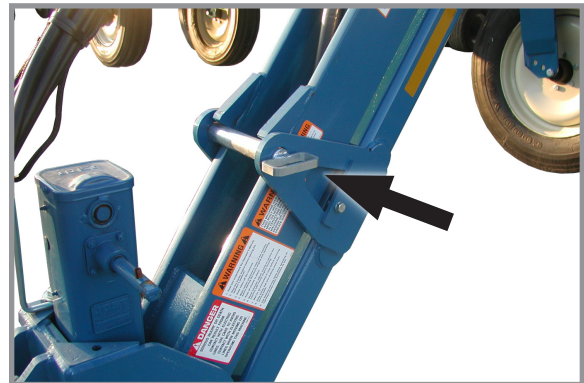

Hitch parallel linkage pin installed

A hitch parallel linkage lock pin locks hitch parallel linkage in raised (transport) position.

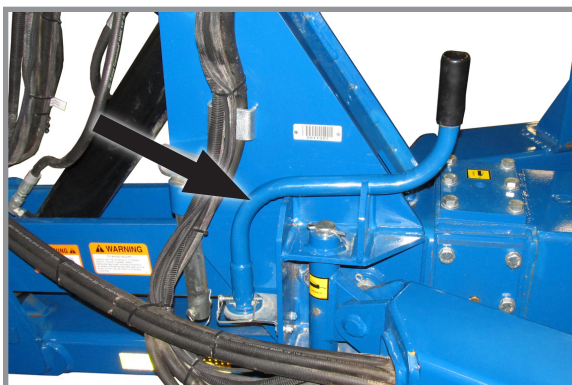
2-SPEED JACK ASSEMBLY

Jack handle stored

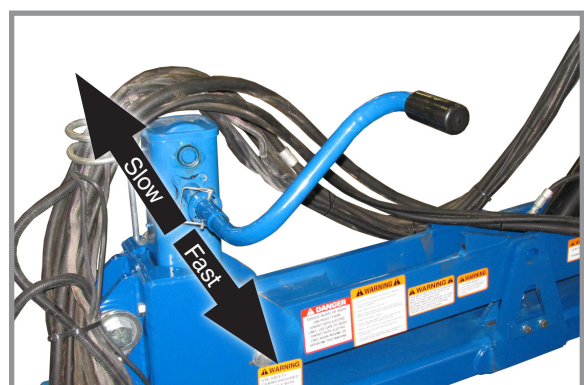

Jack handle installed

Store jack on L.H. side of hitch. Secure in place with spring pin. Install jack on hitch post and secure in place with spring pin. Pull out on handle for high speed or push in on handle for low speed operation.

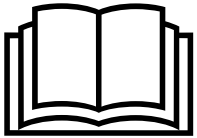
 **WARNING**

Improperly operating or working on this equipment could result in death or serious injury. Read and follow all instructions in Operator Manual before operating or working on this equipment.

INITIAL PLANTER PREPARATION

Following information is general in nature to aid in preparation of tractor and planter for use, and to provide general operating procedures. Operator experience, familiarity with the machine, and the following information should combine for efficient planter operation and good working habits.

 **WARNING**

Explosive separation of rim and tire parts can cause death or serious injury. Overinflation, rim and tire servicing, improper use of rims and tires, or worn or improperly maintained tires could result in a tire explosion.

 **WARNING**

Wheel separation can cause loss of control resulting in death, serious injury, or damage to property and equipment. Check lug nuts on transport wheels are tight before operating planter for first time and periodically after.

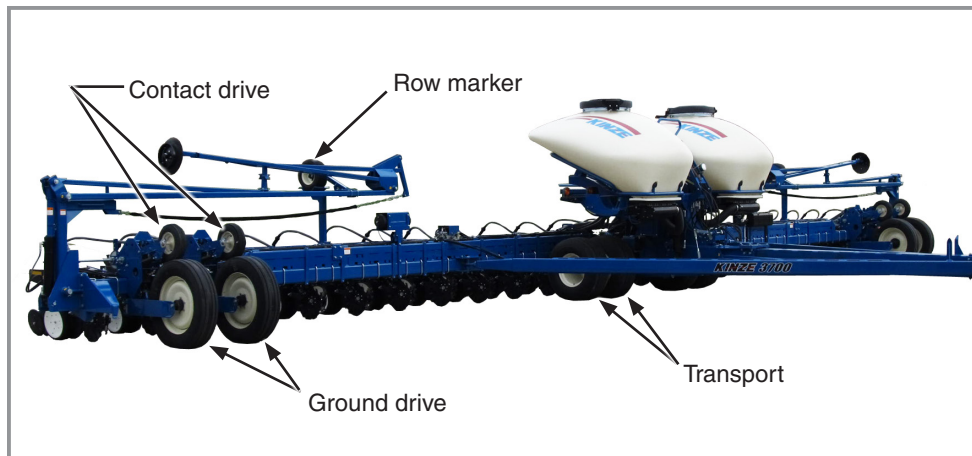

Tire locations (L.H. mirrors R.H. shown)

1. Torque transport wheel $\frac{3}{4}$ "-16 lug nuts to 244 Nm.
2. Inflate tires to the following specifications:
 - Ground drive (wings) - 225 x 70R 22.5 75 PSI (517 kPa)
 - Transport - 36" x 16" x 17.5" 75 PSI (517 kPa)
 - Contact drive - 4.80" x 8" 50 PSI (345 kPa)
 - Row marker - 16" x 6.5" x 8" 14 PSI (97 kPa)
 - Liquid fertilizer piston pump (Not shown) - 4.10" x 6" 50 PSI (345 kPa)
3. Lubricate planter and row units per lubrication information in this manual.
4. Check all drive chains for proper tension, alignment, and lubrication.

TRACTOR PREPARATION AND HOOKUP



Planter control console



Digital vacuum gauge control console

1. Install planter control console (all) and digital vacuum gauge (vacuum only) control consoles on tractor in convenient locations within operator reach and close to hydraulic controls. Mount control consoles securely and route power cables to power source. A power lead adapter may be required. See Lubrication and Maintenance section for wiring schematics.

NOTE: Control console operates on 12 VDC only. If two 6 volt batteries are connected in series, make sure power connection provides 12 VDC across positive terminal on one battery and negative terminal of second battery. ALWAYS make power connection on battery grounded to tractor chassis.

2. Adjust tractor drawbar 33 cm - 43 cm above ground with hitch pin hole directly below PTO shaft center line. Make sure drawbar is in a stationary position.



WARNING

Planter hitch may raise uncontrollably during folding/unfolding and can cause death, serious injury, or damage property and equipment. **DO NOT** fold or unfold planter without planter attached to a tractor. **DO NOT** unhitch planter from tractor unless fully folded for transport or fully unfolded with planting units lowered to ground.

3. Back tractor to planter and connect with minimum 1¼" diameter hitch pin. Make sure hitch pin is secured with a locking pin or cotter pin. If tractor is not equipped with a hitch pin locking device.

NOTE: DO NOT install safety chain using clevis mounting hardware. Safety chain MUST be installed separately.

4. Safety chain must be used to keep planter and tractor connected in case of a hitch pin/drawbar failure. Attach safety chain at an unused clevis mounting hole on the planter hitch. Torque hardware to 1140 Nm.

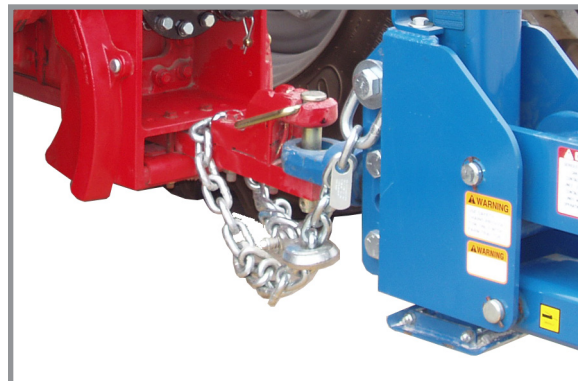

Tractor and safety chain hookup

**WARNING**

Pressurized hydraulic fluid can penetrate body tissue and result in death, serious infection, or other injuries. Fluid injected under skin must be **IMMEDIATELY** removed by a surgeon familiar with this type of injury. Make sure connections are tight and hoses and fittings are not damaged before applying system pressure. Leaks can be invisible. Keep away from suspected leaks. Relieve pressure before searching for leaks or performing any system maintenance.

NOTICE

Wipe hose ends to remove any dirt before connecting couplers to tractor parts or contamination may cause equipment failure.

5. Connect hydraulic hoses to tractor ports in a sequence familiar and comfortable to the operator.

NOTICE

Connect hydraulic motor case drain to a case drain return line with zero PSI on tractor. Failure to connect to a return with zero PSI will cause hydraulic motor shaft seal damage. **DO NOT** connect hydraulic motor case drain to a SCV outlet or motor return circuit connection. Contact tractor manufacturer for specific details on “zero pressure return”.

NOTICE

Always connect hydraulic motor return hose to tractor motor return port. Do not connect to tractor SCV unless through a motor spool or hydraulic motor failure can occur. If a motor return port is not available on the tractor, the SCV controlling the bulk fill system **MUST** be in the float position before planter is moved in planting or field raised position when bulk fill system is not in use.

NOTICE

Clean and grease PTO shaft coupling with high-pressure industrial coupling grease (Chevron® coupling grease or equivalent) meeting AGMA CG-1 and CG-2 Standards each time driveshaft is installed or premature wear and equipment failure can occur.

NOTE: A tractor model-specific PTO mount kit is and available from Ag Power Systems, LLC (agpowersystems.com).

6. (If applicable) Install PTO pump onto tractor PTO shaft. Make sure shaft rotation matches direction indicated on pump housing.
7. Connect ASABE Standards 7 terminal connector for safety/warning lights on planter to ASABE Standards receptacle on tractor. If your tractor is not equipped with an ASABE Standards receptacle, check with your tractor manufacturer for availability. Check warning lights on planter work in conjunction with warning lights on tractor.

NOTE: A 12V battery connection is required to power the vacuum fan digital gauge. Connect “red” wire to positive (+) battery terminal and “black” wire to negative (-) battery terminal.

Completely raise parking jack to prevent damage to jack assembly and equipment when moving planter.

TRANSPORTING PLANTER



WARNING

Loss of control of equipment during transport can result in death, serious injury, or damage to property and equipment. Tractor gross weight must be greater than planter gross weight with attachments and options.



WARNING



Uncontrolled movement of equipment can cause loss of control and could result in death, serious injury, or damage to property and equipment. Install all safety pins before transporting equipment.



WARNING



Uncontrolled machine movement can crush or cause loss of control resulting in death, serious injury, or damage to property and equipment. Install all safety lockup devices before working under or transporting this equipment.



WARNING

Transporting planter with hoppers over half full or unevenly loaded can cause loss of control and could result in death, serious injury, or damage to property and equipment. Properly load planter when transporting. Be aware of extra transport weight, and road conditions and limits.

Make sure safety/warning lights, reflective decals, and SMV sign are in place and visible before transporting machine on public roads. It is your responsibility to check and comply with all federal, state/provincial, and local regulations.

Be aware of road and bridge weight limits. Allow for additional weight of added options and any additional material or substances that have been added to the machine.

CYLINDER INFORMATION

	Master Cylinder	Slave Cylinder	Hitch Parallel Cylinder	Assist Cylinder	Row Marker Cylinder	Helper Cylinder (R.H. side)	Tongue Cylinder (24R 20/22")	Tongue Cylinder (24R 30/36R 20)
Intended Use	Double Acting Applications	Double Acting Applications	Double Acting Applications	Double Acting Applications	Double Acting Applications	Double Acting Applications	Double Acting Applications	Double Acting Applications
Piston	Ductile Iron	Ductile Iron	Ductile Iron	Ductile Iron	Ductile Iron	Ductile Iron	Ductile Iron	Ductile Iron
Gland	Ductile Iron	Ductile Iron	Ductile Iron	Ductile Iron	Ductile Iron	Ductile Iron	Ductile Iron	Ductile Iron
Tube	ST 52 DOM Tubing	ST 52 DOM Tubing	ST 52 DOM Tubing	ST 52 DOM Tubing	ST 52 DOM Tubing	ST 52 DOM Tubing	ST 52 Pre-honed	ST 52 Pre-honed
Rod	1045 Nitro Rod	1045 Nitro Rod	1045 Nitro Rod	1045 Nitro Rod	1045 Nitro Rod	1045 Nitro Rod	1045 Chrome Rod	1045 Chrome Rod
End Mounts	Tang	Tang	Tang	Tang	Sleeve	Trunnion	Sleeve	Sleeve
Tube Seal	Buna O-Ring with Polytemp Back-up	Buna O-Ring with Polytemp Back-up	Buna O-Ring with Polytemp Back-up	Buna O-Ring with Polytemp Back-up	Buna O-Ring with Polytemp Back-up	Buna O-Ring with Polytemp Back-up	Buna O-Ring with Polytemp Back-up	Buna O-Ring with Polytemp Back-up
Rod Seal	Polyester Alloy U-cup	Polyester Alloy U-cup	Polyester Alloy U-cup	Polyester Alloy U-cup	Polyester Alloy U-cup	Polyester Alloy U-cup	Polyester Alloy U-cup	Polyester Alloy U-cup
Rod Wiper	Polyester Alloy Snap In	Polyester Alloy Snap In	Polyester Alloy Snap In	Polyester Alloy Snap In	Polyester Alloy Snap In	Polyester Alloy Snap In	Polyester Alloy Snap In	Polyester Alloy Snap In
Piston Seal	PTFE Seal	PTFE Seal	PTFE Seal	PTFE Seal	T-Seal	T-Seal	PTFE Seal	PTFE Seal
Specifications								
Product Category	Hydraulic Cylinder	Hydraulic Cylinder	Hydraulic Cylinder	Hydraulic Cylinder	Hydraulic Cylinder	Hydraulic Cylinder	Hydraulic Cylinder	Hydraulic Cylinder
Maximum Stroke	10" (254 mm)	20" (508 mm)	20" (508 mm)	10" (254 mm)	20" (508 mm)	13.265" (336 mm)	132" (335 cm)	162" (157.4 cm)
Working Pressure	3000 PSI (20700 kPa)	3000 PSI (20700 kPa)	3000 PSI (20700 kPa)	3000 PSI (20700 kPa)	3000 PSI (20700 kPa)	3000 PSI (20700 kPa)	3000 PSI (20700 kPa)	3000 PSI (20700 kPa)
Bore Size	4.5" (114 mm)	4.75" (120 mm)	3.5" (88 mm)	3" (76 mm)	3.5" (88 mm)	4" (101 mm)	4" (101 mm)	4" (101 mm)
Shaft Diameter	2" (51 mm)	2" (51 mm)	2.5" (63 mm)	1.75" (44 mm)	1.5" (38 mm)	1.5" (38 mm)	2.5" (63 mm)	2.5" (63 mm)
Cylinder Configuration	Simple	Simple	Simple	Simple	Simple	Simple	Simple	Simple
Cylinder Action	Double	Double	Double	Double	Double	Double	Double	Double
Material	Steel, Ductile Iron	Steel, Ductile Iron	Steel, Ductile Iron	Steel, Ductile Iron	Steel, Ductile Iron	Steel, Ductile Iron	Steel, Ductile Iron	Steel, Ductile Iron
Mounting Method	Tang	Tang	Tang	Tang	Sleeve	Trunnion	Sleeve	Sleeve
Mount Location	End Cap	End Cap	End Cap	End Cap	End Cap	End Cap	End Cap	End Cap
Cylinder Style	Welded	Welded	Welded	Welded	Welded	Welded	Welded	Welded

HYDRAULIC HOSE INFORMATION

Part Number	A1044	A1412	A1499	A1498	A1089	A3141
Description	Hose Assembly, 3/8" x 34" (0.86 m)	Hose Assembly, 1/2" x 130" (3.30 m)	Hose Assembly, 1/2" x 280" (7.11 m)	Hose Assembly, 1/2" x 452" (11.4 m)	Hose Assembly, 3/8" x 240" (6.09 m)	Hose Assembly, 3/8" x 260" (6.60 m)
Product Category	Hydraulic Hose	Hydraulic Hose	Hydraulic Hose	Hydraulic Hose	Hydraulic Hose	Hydraulic Hose
Product Form	Hose; Assembly	Hose; Assembly	Hose; Assembly	Hose; Assembly	Hose; Assembly	Hose; Assembly
I.D.	3/8" (9.5 mm)	1/2" (12.7 mm)	1/2" (12.7 mm)	1/2" (12.7 mm)	3/8" (9.5 mm)	3/8" (9.5 mm)
O.D.	1 1/16" (17.5 mm)	1 3/16" (20.6 mm)	1 3/16" (20.6 mm)	1 3/16" (20.6 mm)	1 1/16" (17.5 mm)	1 1/16" (17.5 mm)
Minimum Bend Radius	2 1/2" (64 mm)	3 1/2" (89 mm)	3 1/2" (89 mm)	3 1/2" (89 mm)	2 1/2" (64 mm)	2 1/2" (64 mm)
Working Pressure	3000 PSI (20700 kPa)	3000 PSI (20700 kPa)	3000 PSI (20700 kPa)	3000 PSI (20700 kPa)	3000 PSI (20700 kPa)	3000 PSI (20700 kPa)
Temperature Range	-40°C - +100°C	-40°C - +100°C	-40°C - +100°C	-40°C - +100°C	-40°C - +100°C	-40°C - +100°C
Material	Modified Nitrile Type C2	Modified Nitrile Type C2	Modified Nitrile Type C2	Modified Nitrile Type C2	Modified Nitrile Type C2	Modified Nitrile Type C2
Specialized Construction	High tensile steel wire	High tensile steel wire	High tensile steel wire	High tensile steel wire	High tensile steel wire	High tensile steel wire
Media	Hydraulic Fluid	Hydraulic Fluid	Hydraulic Fluid	Hydraulic Fluid	Hydraulic Fluid	Hydraulic Fluid
Application	Agricultural; Construction	Agricultural; Construction	Agricultural; Construction	Agricultural; Construction	Agricultural; Construction	Agricultural; Construction

Part Number	A1487	A3196	A3212	A1404	A1072	A1049
Description	Hose Assembly, 1/2" x 150" (3.8 m)	Hose Assembly, 3/8" x 240" (6.09 m)	Hose Assembly, 3/8" x 260" (6.60 m)	Hose Assembly, 1/2" x 41" (1.0 m) (10F - 10F)	Hose Assembly, 3/8" x 48" (1.21 m)	Hose Assembly, 3/8" x 160" (4.06 m)
Product Category	Hydraulic Hose	Hydraulic Hose	Hydraulic Hose	Hydraulic Hose	Hydraulic Hose	Hydraulic Hose
Product Form	Hose; Assembly	Hose; Assembly	Hose; Assembly	Hose; Assembly	Hose; Assembly	Hose; Assembly
I.D.	1/2" (12.7 mm)	3/8" (9.5 mm)	3/8" (9.5 mm)	1/2" (12.7 mm)	3/8" (9.5 mm)	3/8" (9.5 mm)
O.D.	1 3/16" (20.6 mm)	1 1/16" (17.5 mm)	1 1/16" (17.5 mm)	1 3/16" (20.6 mm)	1 1/16" (17.5 mm)	1 1/16" (17.5 mm)
Minimum Bend Radius	3 1/2" (89 mm)	2 1/2" (64 mm)	2 1/2" (64 mm)	3 1/2" (89 mm)	2 1/2" (64 mm)	2 1/2" (51 mm)
Working Pressure	3000 PSI (20700 kPa)	3000 PSI (20700 kPa)	3000 PSI (20700 kPa)	3000 PSI (20700 kPa)	3250 PSI (22400 kPa)	3000 PSI (20700 kPa)
Temperature Range	-40°C - +100°C	-40°C - +100°C	-40°C - +100°C	-40°C - +100°C	-40°C - +100°C	-40°C - +100°C
Material	Modified Nitrile Type C2	Modified Nitrile Type C2	Modified Nitrile Type C2	Modified Nitrile Type C2	Modified Nitrile Type C2	Modified Nitrile Type C2
Specialized Construction	High tensile steel wire	High tensile steel wire	High tensile steel wire	Single Wire Braid	High tensile steel wire	High tensile steel wire
Media	Hydraulic Fluid	Hydraulic Fluid	Hydraulic Fluid	Hydraulic Fluid	Hydraulic Fluid	Hydraulic Fluid
Application	Agricultural; Construction	Agricultural; Construction	Agricultural; Construction	Agricultural; Construction	Agricultural; Construction	Agricultural; Construction

HYDRAULIC HOSE INFORMATION

Part Number	A3175	A1020	A1010	A3271	A3272	A3119
Description	Hose Assembly, 3/8" x 38" (0.97 m)	Hose Assembly, 3/8" x 38" (0.97 m)	Hose Assembly, 3/8" x 120" (3.05 m)	Hose Assembly, 3/8" x 402" (10.21 m)	Hose Assembly, 3/8" x 426" (10.82 m)	Hose Assembly, 3/8" x 36" (0.91 m)
Product Category	Hydraulic Hose	Hydraulic Hose	Hydraulic Hose	Hydraulic Hose	Hydraulic Hose	Hydraulic Hose
Product Form	Hose; Assembly	Hose; Assembly	Hose; Assembly	Hose; Assembly	Hose; Assembly	Hose; Assembly
I.D.	3/8" (9.5 mm)	3/8" (9.5 mm)	3/8" (9.5 mm)	3/8" (9.5 mm)	3/8" (9.5 mm)	3/8" (9.5 mm)
O.D.	1 1/16" (17.5 mm)	1 1/16" (17.5 mm)	1 1/16" (17.5 mm)	1 1/16" (17.5 mm)	1 1/16" (17.5 mm)	1 1/16" (17.5 mm)
Minimum Bend Radius	2 1/2" (64 mm)	2 1/2" (64 mm)	2 1/2" (64 mm)	2 1/2" (64 mm)	2 1/2" (64 mm)	2 1/2" (64 mm)
Working Pressure	3000 PSI (20700 kPa)	3000 PSI (20700 kPa)	3000 PSI (20700 kPa)	3000 PSI (20700 kPa)	3000 PSI (20700 kPa)	3000 PSI (20700 kPa)
Temperature Range	-40°C - +100°C	-40°C - +100°C	-40°C - +100°C	-40°C - +100°C	-40°C - +100°C	-40°C - +100°C
Material	Modified Nitrile Type C2	Modified Nitrile Type C2	Modified Nitrile Type C2	Modified Nitrile Type C2	Modified Nitrile Type C2	Modified Nitrile Type C2
Specialized Construction	High tensile steel wire	High tensile steel wire	High tensile steel wire	High tensile steel wire	High tensile steel wire	High tensile steel wire
Media	Hydraulic Fluid	Hydraulic Fluid	Hydraulic Fluid	Hydraulic Fluid	Hydraulic Fluid	Hydraulic Fluid
Application	Agricultural; Construction	Agricultural; Construction	Agricultural; Construction	Agricultural; Construction	Agricultural; Construction	Agricultural; Construction

Part Number	A1475	A1057	A1019	A1146	A1189	A12026
Description	Hose Assembly, 1/2" x 108" (2.74 m)	Hose Assembly, 3/8" x 216" (5.48 m)	Hose Assembly, 3/8" x 44" (1.11 m)	Hose Assembly, 1/4" x 12" (0.30 m)	Hose Assembly, 1/4" x 36" (0.91 m)	Hose Assembly, 3/8" x 148" (3.76 m)
Product Category	Hydraulic Hose	Hydraulic Hose	Hydraulic Hose	Hydraulic Hose	Hydraulic Hose	Hydraulic Hose
Product Form	Hose; Assembly	Hose; Assembly	Hose; Assembly	Hose; Assembly	Hose; Assembly	Hose; Assembly
I.D.	1/2" (12.7 mm)	3/8" (9.5 mm)	3/8" (9.5 mm)	1/4" (6.4 mm)	1/4" (6.4 mm)	3/8" (9.5 mm)
O.D.	1 3/16" (20.6 mm)	1 1/16" (17.5 mm)	1 1/16" (17.5 mm)	1 7/32" (13.5 mm)	1 7/32" (13.5 mm)	1 1/16" (17.5 mm)
Minimum Bend Radius	3 1/2" (89 mm)	2 1/2" (64 mm)	2 1/2" (64 mm)	4" (102 mm)	4" (102 mm)	2 1/2" (64 mm)
Working Pressure	3000 PSI (20700 kPa)	3000 PSI (20700 kPa)	3000 PSI (20700 kPa)	3275 PSI (22600 kPa)	3275 PSI (22600 kPa)	3000 PSI (20700 kPa)
Temperature Range	-40°C - +100°C	-40°C - +100°C	-40°C - +100°C	-40°C - +100°C	-40°C - +100°C	-40°C - +100°C
Material	Modified Nitrile Type C2	Modified Nitrile Type C2	Modified Nitrile Type C2	Modified Nitrile Type C2	Modified Nitrile Type C2	Modified Nitrile Type C2
Specialized Construction	High tensile steel wire	High tensile steel wire	High tensile steel wire	High tensile steel wire	High tensile steel wire	High tensile steel wire
Media	Hydraulic Fluid	Hydraulic Fluid	Hydraulic Fluid	Hydraulic Fluid	Hydraulic Fluid	Hydraulic Fluid
Application	Agricultural; Construction	Agricultural; Construction	Agricultural; Construction	Agricultural; Construction	Agricultural; Construction	Agricultural; Construction

HYDRAULIC HOSE INFORMATION

Part Number	A1424	A1025	A3105	A1013	A15022	A1073
Description	Hose Assembly ½" x 30" (0.76 m)	Hose Assembly ⅜" x 148" (3.76 m)	Hose Assembly ⅜" x 170" (4.32 m)	Hose Assembly ⅜" x 150" (3.81 m)	Hose Assembly ⅜" x 438" (11.13 m)	Hose Assembly ⅜" x 18" (0.46 m)
Product Category	Hydraulic Hose	Hydraulic Hose	Hydraulic Hose	Hydraulic Hose	Hydraulic Hose	Hydraulic Hose
Product Form	Hose; Assembly	Hose; Assembly	Hose; Assembly	Hose; Assembly	Hose; Assembly	Hose; Assembly
I.D.	½" (12.7 mm)	⅜" (9.5 mm)	⅜" (9.5 mm)	⅜" (9.5 mm)	⅜" (9.5 mm)	⅜" (9.5 mm)
O.D.	⅜" (20.6 mm)	1½" (17.5 mm)	1½" (17.5 mm)	1½" (17.5 mm)	1½" (17.5 mm)	1½" (17.5 mm)
Minimum Bend Radius	3½" (89 mm)	2½" (64 mm)	2½" (64 mm)	2½" (64 mm)	2½" (64 mm)	2½" (64 mm)
Working Pressure	3000 PSI (20700 kPa)	3000 PSI (20700 kPa)	3000 PSI (20700 kPa)	3000 PSI (20700 kPa)	3000 PSI (20700 kPa)	3000 PSI (20700 kPa)
Temperature Range	-40°C - +100°C	-40°C - +100°C	-40°C - +100°C	-40°C - +100°C	-40°C - +100°C	-40°C - +100°C
Material	Modified Nitrile Type C2	Modified Nitrile Type C2	Modified Nitrile Type C2	Modified Nitrile Type C2	Modified Nitrile Type C2	Modified Nitrile Type C2
Specialized Construction	Single Wire Braid	Single Wire Braid	Single Wire Braid	Single Wire Braid	Single Wire Braid	Single Wire Braid
Media	Hydraulic Fluid	Hydraulic Fluid	Hydraulic Fluid	Hydraulic Fluid	Hydraulic Fluid	Hydraulic Fluid
Application	Agricultural and Construction	Agricultural; Construction	Agricultural; Construction	Agricultural; Construction	Agricultural; Construction	Agricultural; Construction

Part Number	A8500	A3140	A3111	A1026	A1031	A3161
Description	Hose Assembly ⅜" x 260" (6.60 m)	Hose Assembly ⅜" x 94" (2.39 m)	Hose Assembly ⅜" x 200" (5.08 m) (08F - 08F)	Hose Assembly ⅜" x 152" (3.86 m)	Hose Assembly ⅜" x 234" (5.94 m)	Hose Assembly ⅜" x 210" (5.33 m)
Product Category	Hydraulic Hose	Hydraulic Hose	Hydraulic Hose	Hydraulic Hose	Hydraulic Hose	Hydraulic Hose
Product Form	Hose; Assembly	Hose; Assembly	Hose; Assembly	Hose; Assembly	Hose; Assembly	Hose; Assembly
I.D.	⅜" (9.5 mm)	⅜" (9.5 mm)	⅜" (9.5 mm)	⅜" (9.5 mm)	⅜" (9.5 mm)	⅜" (9.5 mm)
O.D.	.42" (11.0 mm)	1½" (17.5 mm)	1½" (17.5 mm)	1½" (17.5 mm)	1½" (17.5 mm)	1½" (17.5 mm)
Minimum Bend Radius	¾" (19.0 mm)	2½" (64 mm)	2½" (64 mm)	2½" (64 mm)	2½" (64 mm)	2½" (64 mm)
Working Pressure	3500 PSI (24100 kPa)	3000 PSI (20700 kPa)	3000 PSI (20700 kPa)	3000 PSI (20700 kPa)	3000 PSI (20700 kPa)	3000 PSI (20700 kPa)
Temperature Range	-40°C - +100°C	-40°C - +100°C	-40°C - +100°C	-40°C - +100°C	-40°C - +100°C	-40°C - +100°C
Material	Modified Nitrile Type C2	Modified Nitrile Type C2	Modified Nitrile Type C2	Modified Nitrile Type C2	Modified Nitrile Type C2	Modified Nitrile Type C2
Specialized Construction	Single Wire Braid	Single Wire Braid	Single Wire Braid	Single Wire Braid	Single Wire Braid	Single Wire Braid
Media	Hydraulic Fluid	Hydraulic Fluid	Hydraulic Fluid	Hydraulic Fluid	Hydraulic Fluid	Hydraulic Fluid
Application	Agricultural; Construction	Agricultural; Construction	Agricultural; Construction	Agricultural; Construction	Agricultural; Construction	Agricultural; Construction

HYDRAULIC HOSE INFORMATION

Part Number	A3299	A8201	A12000	A1485	A8208	A8273
Description	Hose Assembly 3/8" x 164" (4.17 m)	Hose Assembly, 1/2" x 90" (2.29 m)	Hose Assembly, 3/8" x 548" (13.92 m)	Hose Assembly, 1/2" x 330" (8.38 m)	Hose Assembly, 1/2" x 374" (9.51 m)	Hose Assembly, 1/2" x 21" (0.53 m)
Product Category	Hydraulic Hose	Hydraulic Hose	Hydraulic Hose	Hydraulic Hose	Hydraulic Hose	Hydraulic Hose
Product Form	Hose; Assembly	Hose; Assembly	Hose; Assembly	Hose; Assembly	Hose; Assembly	Hose; Assembly
I.D.	3/8" (9.5 mm)	1/2" (12.7 mm)	3/8" (9.5 mm)	1/2" (12.7 mm)	1/2" (12.7 mm)	1/2" (12.7 mm)
O.D.	1 1/16" (16.0 mm)	1 3/16" (20.6 mm)	1 1/16" (16.0 mm)	1 3/16" (20.6 mm)	1 3/16" (20.6 mm)	1 3/16" (20.6 mm)
Minimum Bend Radius	2 1/2" (64 mm)	3 1/2" (89 mm)	2 1/2" (64 mm)	3 1/2" (89 mm)	3 1/2" (89 mm)	3 1/2" (89 mm)
Working Pressure	3000 PSI (20700 kPa)	3000 PSI (20700 kPa)	3000 PSI (20700 kPa)	3000 PSI (20700 kPa)	3250 PSI (22400 kPa)	3000 PSI (20700 kPa)
Temperature Range	-40°C - +100°C	-40°C - +100°C	-40°C - +100°C	-40°C - +100°C	-40°C - +100°C	-40°C - +100°C
Material	Modified Nitrile Type C2	Modified Nitrile Type C2	Modified Nitrile Type C2	Modified Nitrile Type C2	Modified Nitrile Type C2	Modified Nitrile Type C2
Specialized Construction	Single Wire Braid	High tensile steel wire	High tensile steel wire	High tensile steel wire	High tensile steel wire	High tensile steel wire
Media	Hydraulic Fluid	Hydraulic Fluid	Hydraulic Fluid	Hydraulic Fluid	Hydraulic Fluid	Hydraulic Fluid
Application	Agricultural; Construction	Agricultural; Construction	Agricultural; Construction	Agricultural; Construction	Agricultural; Construction	Agricultural; Construction

Part Number	A12749	A1465	A8501	A8503	A12082	A1038
Description	Hose Assembly, 1/2" x 198" (5.03 m)	Hose Assembly, 1/2" x 84" (2.13 m)	Hose Assembly 3/16" x 426" (10.82 m)	Hose Assembly 3/16" x 436" (11.07 m)	Hose Assembly, 3/8" x 418" (10.62 m)	Hose Assembly, 3/8" x 370" (9.41 m)
Product Category	Hydraulic Hose	Hydraulic Hose	Hydraulic Hose	Hydraulic Hose	Hydraulic Hose	Hydraulic Hose
Product Form	Hose; Assembly	Hose; Assembly	Hose; Assembly	Hose; Assembly	Hose; Assembly	Hose; Assembly
I.D.	1/2" (12.7 mm)	1/2" (12.7 mm)	3/16" (4.7 mm)	3/16" (4.7 mm)	3/8" (9.5 mm)	3/8" (9.5 mm)
O.D.	1 3/16" (20.6 mm)	1 3/16" (20.6 mm)	.42" (10.2 mm)	.42" (10.2 mm)	1 1/16" (17.5 mm)	1 1/16" (17.5 mm)
Minimum Bend Radius	3 1/2" (89 mm)	3 1/2" (89 mm)	3/4" (19 mm)	3/4" (19 mm)	2 1/2" (64 mm)	2 1/2" (64 mm)
Working Pressure	3000 PSI (20700 kPa)	3000 PSI (20700 kPa)	3500 PSI (24100 kPa)	3500 PSI (24100 kPa)	3000 PSI (20700 kPa)	3000 PSI (20700 kPa)
Temperature Range	-40°C - +100°C	-40°C - +100°C	-40°C - +100°C	-40°C - +100°C	-40°C - +100°C	-40°C - +100°C
Material	Modified Nitrile Type C2	Modified Nitrile Type C2	Modified Nitrile Type C2	Modified Nitrile Type C2	Modified Nitrile Type C2	Modified Nitrile Type C2
Specialized Construction	High tensile steel wire	High tensile steel wire	Single Wire Braid	Single Wire Braid	High tensile steel wire	High tensile steel wire
Media	Hydraulic Fluid	Hydraulic Fluid	Hydraulic Fluid	Hydraulic Fluid	Hydraulic Fluid	Hydraulic Fluid
Application	Agricultural; Construction	Agricultural; Construction	Agricultural; Construction	Agricultural; Construction	Agricultural; Construction	Agricultural; Construction

HYDRAULIC HOSE INFORMATION

Part Number	A8283	A3122	A12083	A8502	A3178	A1098
Description	Hose Assembly, 1/2" x 158" (4.01 m)	Hose Assembly 3/8" x 10.5" (0.31 m)	Hose Assembly 3/8" x 436" (11.10 m)	Hose Assembly 3/16" x 270" (6.91 m)	Hose Assembly, 3/8" x 536" (13.61 m)	Hose Assembly, 3/8" x 26" (0.66 m)
Product Category	Hydraulic Hose	Hydraulic Hose	Hydraulic Hose	Hydraulic Hose	Hydraulic Hose	Hydraulic Hose
Product Form	Hose; Assembly	Hose; Assembly	Hose; Assembly	Hose; Assembly	Hose; Assembly	Hose; Assembly
I.D.	1/2" (12.7 mm)	3/8" (9.5 mm)	3/8" (9.5 mm)	3/16" (4.7 mm)	3/8" (9.5 mm)	3/8" (9.5 mm)
O.D.	13/16" (20.6 mm)	1 1/16" (17.5 mm)	1 1/16" (17.5 mm)	.42" (10.2 mm)	1 1/16" (17.5 mm)	1 1/16" (17.5 mm)
Minimum Bend Radius	3 1/2" (89 mm)	2 1/2" (64 mm)	2 1/2" (64 mm)	3/4" (7.6 cm)	2 1/2" (64 mm)	2 1/2" (51 mm)
Working Pressure	3000 PSI (20700 kPa)	3000 PSI (20700 kPa)	3000 PSI (20700 kPa)	3500 PSI (24100 kPa)	3000 PSI (20700 kPa)	3000 PSI (20700 kPa)
Temperature Range	-40°C - +100°C	-40°C - +100°C	-40°C - +100°C	-40°C - +100°C	-40°C - +100°C	-40°C - +100°C
Material	Modified Nitrile Type C2	Modified Nitrile Type C2	Modified Nitrile Type C2	Modified Nitrile Type C2	Modified Nitrile Type C2	Modified Nitrile Type C2
Specialized Construction	High tensile steel wire	Single Wire Braid	Single Wire Braid	Single Wire Braid	High tensile steel wire	High tensile steel wire
Media	Hydraulic Fluid	Hydraulic Fluid	Hydraulic Fluid	Hydraulic Fluid	Hydraulic Fluid	Hydraulic Fluid
Application	Agricultural; Construction	Agricultural; Construction	Agricultural; Construction	Agricultural; Construction	Agricultural; Construction	Agricultural; Construction

LEVEL PLANTER

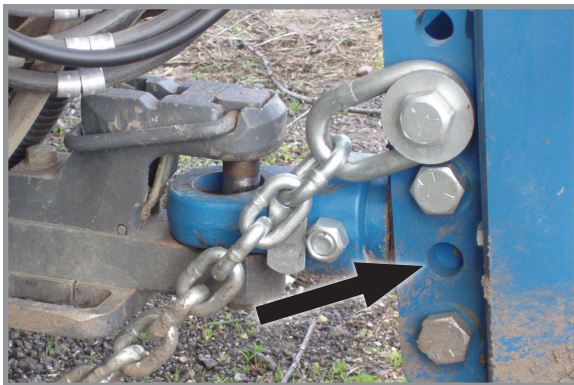

Clevis adjustment holes

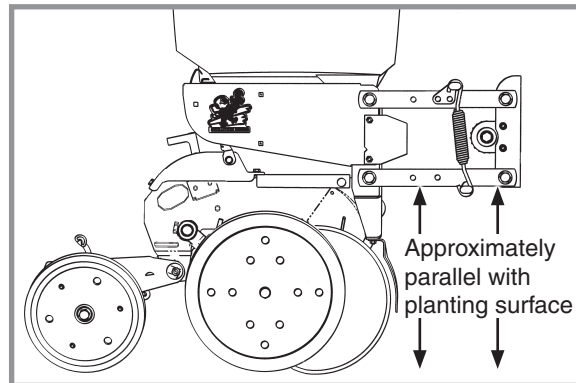

Level row units

Toolbar should operate at 50 cm - 56 cm height from planting surface. Tire pressures must be maintained at pressures specified for planter to operate level laterally. Check toolbar and row unit parallel arms are level front to back with planter lowered to proper operating height.

Five holes in the hitch bracket allow clevis to be raised or lowered. Clevis may be turned over for a finer adjustment between mounting holes. Torque hardware to 1138.8 Nm.

Field and actual planting conditions determine which wheel settings to use to ensure row unit parallel arms are approximately parallel with planting surface. If planting in extremely soft soil conditions it may be necessary to move ground drive tires to lower sets of mounting holes. To allow adequate drive force after lowering the ground drive tires, it may be necessary to lower contact drive arms to lower set of holes in wheel module and relocate down pressure springs to lower mounting rod on wheel module.

If planter center is higher or lower than wings after rephasing, contact your Kinze Dealer for valve adjustment or maintenance.

CONTACT WHEEL SPRING ADJUSTMENT

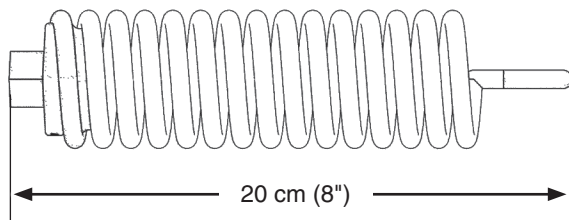

Spring length measurement (Factory setting)

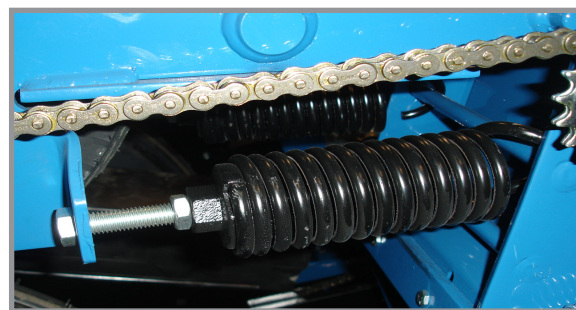

Contact drive springs

There are two down pressure springs on each contact drive wheel. Spring tension is factory set to approximately 90 kg of down force at tire contact point and should require no further adjustment.

NOTE: Measurement must be taken in planting position with proper tire pressure.

CONTACT WHEEL DRIVE SPROCKETS



Contact wheel drive



Optional half-rate drive sprocket

Contact wheel drive works the same for mechanical or vacuum planters except for sprocket size. Chain tension is controlled by a spring-loaded sprocket idler. Planting rate charts in “Rate Chart” section help you select correct sprockets.

NOTE: Make a field test after each sprocket combination change to be sure you are planting at desired rate.

22 tooth, 28 tooth or 44 tooth sprockets at each contact drive wheel can be exchanged with sprockets on storage rod bolted to wheel module on each side of planter chains. 22 tooth sprockets require 148 pitch No. 40 chains. 28 tooth sprockets require 150 pitch chains. 44 tooth sprockets require use 158 pitch chains.

NOTE: 22, 28 and 44 tooth drive sprockets do NOT apply to all rate charts. Check chart titles to make sure proper rate chart is selected.

NOTE: 54 cell sunflower disc uses 15 tooth drive sprocket at contact wheels and 28 tooth drive sprocket at wheel module reverser plates with 19 tooth sprocket. 15 tooth sprockets require 144 pitch No. 40 chains. Applicable sprockets, chains and instructions supplied in G1K469 Sunflower Rate Reduction Kit.

Seed planting rate charts are based on standard rate drive. Standard rate drive uses a 30 tooth sprocket and No. 40 118 pitch chain on each contact wheel. Optional half-rate (2 to 1) drive is recommended only when population falls below planting rate charts. Replace 30 tooth sprocket on each contact wheel with a 15 tooth sprocket and shorter No. 40 110 pitch chain. This reduces planter transmission speed and planting and application rates by approximately 50%.

SEED RATE TRANSMISSION ADJUSTMENT

Planting population rate changes are made using seed rate transmissions at end of each planter wing. Seed rate transmissions allow simple, rapid changes of sprockets by removing lynch pins on hexagon shafts and changing sprockets with those from the sprocket storage rod bolted to transmissions.

Chain tension is controlled by a spring-loaded dual sprocket idler. Idler assembly is adjusted with a easy-release idler arm with a release position to adjust spring tension for planting or remove spring tension for replacing sprockets. See “Wrap Spring Wrench Operation”.

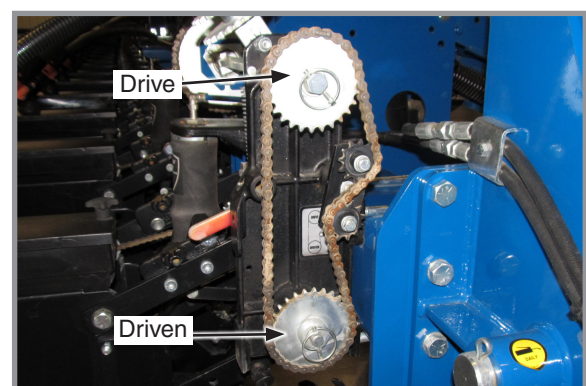

Seed rate transmission

A decal on the transmission (behind chain idler) shows proper chain routing. “Rate Charts” section of this manual will help you select correct sprocket combinations.

WRAP SPRING WRENCH OPERATION

Chain idlers are equipped with wrap spring wrenches. L.H. rotation wrap spring wrenches have a blue release collar and R.H. rotation wrap spring wrenches have a grey or black release collar.

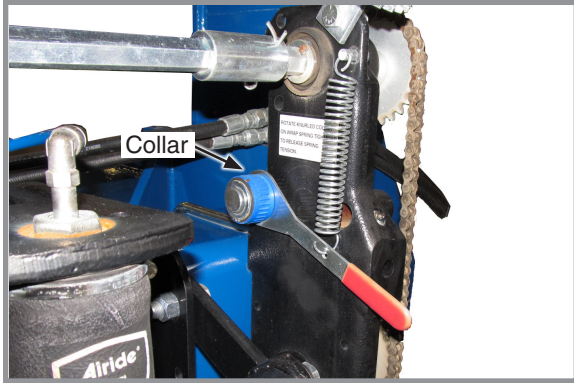

Wrap spring wrench (L.H. rotation shown)



Chain idler tensioning

Rotate collar on wrap spring wrench and pull handle to release chain tension.

Rotate chain idler into chain and pull handle to tension idler spring.

SHEAR PROTECTION

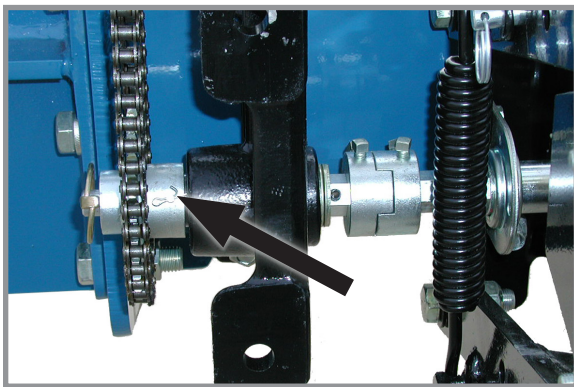

Transmission shaft shear pin



Spare shear pin storage

Planter driveline and seed and granular chemical drivelines are protected from damage by shear pins.

NOTICE	Misalignment of drill shaft/transmission coupler alignment will cause equipment damage.
---------------	--

Determine where binding has occurred if excessive load causes a pin to shear before replacing pin. Replace shear pins with same size and type.

Additional shear pins are in the storage area located at end of each planter wing on inboard side of transport hook.

SLIDING HITCH LINKAGE



Axle link slide (L.H. shown)

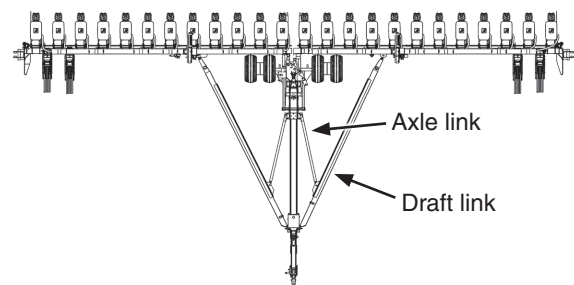

24 Row 70 cm planters are equipped with sliding axle links which connect R.H. and L.H. draft links to transport axle. Axle links move in a slide on inner side of each draft link when planter folds or unfolds. When axle links reach end of slides, main transport axle is telescoped forward into transport position or rearward into field position.

NOTICE

DO NOT GREASE axle link slides or excess dirt accumulation may cause equipment failure. Inspect daily to ensure free movement of axle links in slides. Keep axle link slides clean. Use only powdered graphite if lubrication is desired.

Stops at either end of slides are designed to allow dirt to escape in normal operating conditions. Under extremely dusty conditions it may be necessary to clean slides.

DIGITAL VACUUM GAUGE

Digital vacuum gauge control console is equipped with a power toggle switch, run/stop (fans) toggle switch, and two fan speed control toggle switches for the vacuum fans.

Power switch applies power to control console. Run/stop toggle switch turns both fans on when power switch is ON. Fan speed control switches adjust each fan (left or right).



Digital vacuum gauge control console

PTO PUMP INITIAL STARTUP

1. Fill reservoir with SAE 10W-20 multigrade wide temperature range transmission hydraulic fluid or equivalent.
2. Start system. Allow to run with tractor at idle and fans turned off for 1-2 minutes.
3. Allow to run with tractor at idle and fans at full speed for 1-2 minutes.
4. Check fluid level in reservoir and fill as required.

NOTE: Fluid level in each tank should be within 1.5 cm - 5 cm from top of the tank after pump has run and hydraulic hoses are primed to allow fluid to expand when heated.

5. Bring tractor to PTO speed and adjust flow control to desired vacuum level using switches on vacuum fan control console.

HYDRAULIC/ELECTRIC OPERATION

Control console switches and tractor's hydraulic system are used to raise planter to transport position, operate rotate and tongue extension functions, lock and release planter wings, and raise and lower row markers.

NOTE: Turn console backlighting OFF during extended periods of non-use using push button switch on back of console.



Single point row clutch control box

Two dual remote hydraulic outlets (SCV) are required on all sizes of conventional planters equipped with row markers. Three dual remote hydraulic outlets (SCV) are required on all sizes of bulk fill planters equipped with row markers. One set of outlets is used to operate lift function, one set is used to operate markers, tongue and fold/unfold functions and the third set is used to operate bulk fill functions (If Applicable).

Marker and point row selector switches are an ON-OFF-ON type.

Power to marker switch is fed through auxiliary switch and two transport function switches. Operating any lower row switch disables markers and turns off marker indicator light.

Raise/wing lock and rotate/tongue (fold function) switches are MOMENTARY ON-OFF-MOMENTARY ON type and must be held in position while operating tractor hydraulic SCV control. Activating a fold function switch disables marker circuit.



WARNING

Marker selector switch must be OFF (center position) when not in use to prevent accidental extension which could result in death or serious injury, or damage to property and equipment. An indicator light on control box panel is ON whenever marker circuits or point row clutch circuits are energized.

Auxiliary switch is not used. Keep switch OFF at all times.

NOTE: Activating auxiliary switch disables all other control console switches except point row clutch switch.

TRANSPORT TO FIELD SEQUENCE

Position planter in a relatively flat open area without furrows, etc.

SUMMARIZED TRANSPORT TO FIELD SEQUENCE

1. Remove hitch parallel linkage lock pin or lockup.
2. Lower hitch parallel linkage to release wing hooks.

NOTICE

Unfolding planter without using tractor to assist may cause equipment damage especially in soft conditions or when loaded with seed or fertilizer. Use tractor to reduce stress on frame, drive, and transport components.

3. Place tractor in reverse and hold in clutch. Start unfolding planter and slowly back up tractor as planter unfolds.
4. Raise planter to remove weight from center (slave) lift cylinder lockups and remove lockups.
5. Lower planter.
6. Remove row marker lockups.

NOTE: Read following information for detailed instructions.

**WARNING**

Planter hitch may raise uncontrollably during folding/unfolding and can cause death, serious injury, or damage property and equipment. **DO NOT** fold or unfold planter without planter attached to a tractor. **DO NOT** unhitch planter from tractor unless fully folded for transport or fully unfolded with planting units lowered to ground.

NOTICE

DO NOT LOWER planter frame onto transport axle in folded transport position or transport tires and row units will be damaged.

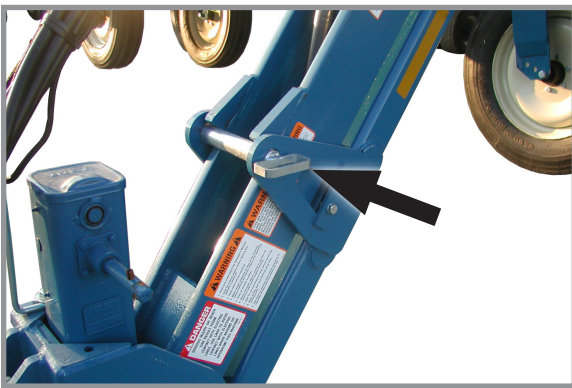

Hitch parallel linkage pin installed

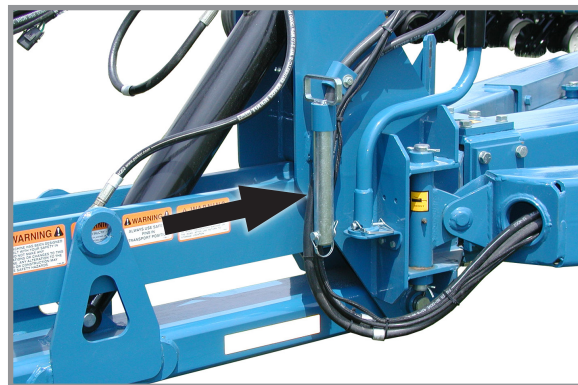

Hitch parallel linkage pin stored

1. Fully extend hitch parallel linkage cylinder located on hitch. Remove hitch parallel linkage lock pin from hitch parallel linkage or cylinder lockup from cylinder rod. Store in location provided.

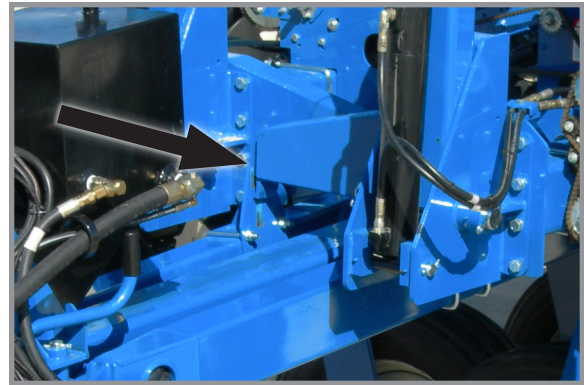
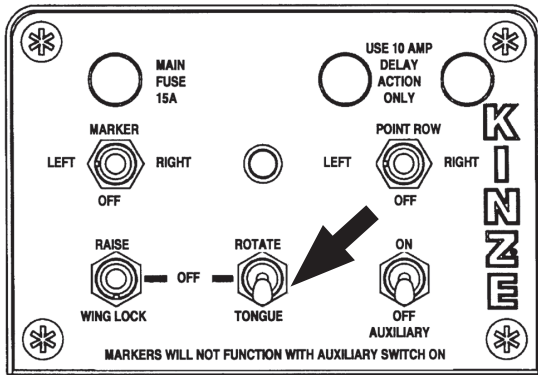

Hitch release from wing hook

2. Hold “ROTATE/TONGUE” switch in “TONGUE” position while operating proper tractor hydraulic control to completely retract hitch parallel linkage cylinder and lower hitch until wing wheels are on ground and hitch has released from hooks on ends of wings.

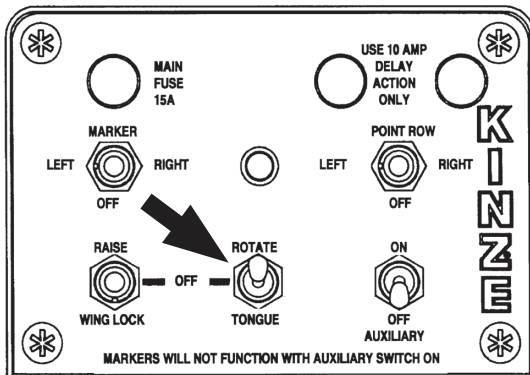

Planter unfolding

NOTICE	<p>Unfolding planter without using tractor to assist may cause equipment damage especially in soft conditions or when loaded with seed or fertilizer. Use tractor to reduce stress on frame, drive, and transport components.</p>
---------------	---

3. Hold control console ROTATE/TONGUE switch in **ROTATE** and operate hydraulic control to unfold planter. Tongue begins to retract and wings (supported by wing wheels) begin to unfold. Place tractor transmission in a low reverse gear and slowly back up as planter unfolds. Center axle tires should remain stationary and wing tires should roll in a continuous arc with minimal side loading on tires or their mounting structures. Hold switch in “ROTATE” position until tongue cylinder is fully retracted.

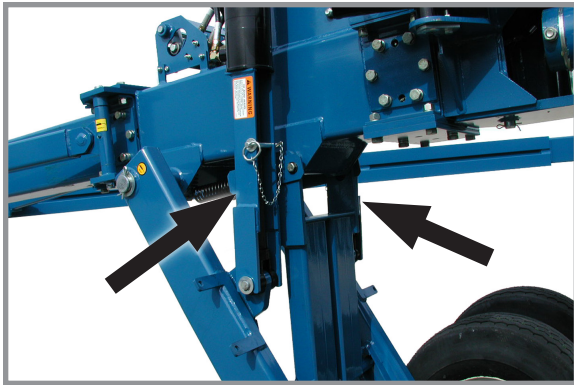

Safety lockups in transport position

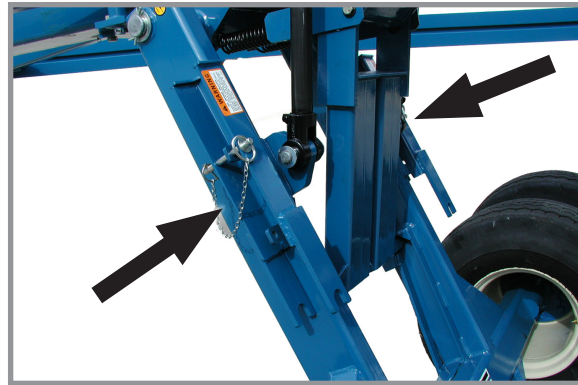

Safety lockups in storage position

NOTE: Automatic safety lock will release when planter is raised to remove weight from center lift cylinder lockups. Raising planter too high will reset the mechanism. If this happens, lower machine until hydraulic system stalls against the automatic safety, raise machine slightly to release automatic safety lock and then lower planter.

4. Raise planter to remove weight from center lift (slave) cylinder safety lockups. Remove pins and safety lockups and place in storage location.
5. Lower machine to ground. Center drops until toolbar is level and then entire planter lowers evenly. Hold tractor's hydraulic lever 5 to 10 seconds to rephase system when all lift cylinders are fully retracted.



Lowering planter



Row marker safety lockup installed



Row marker safety lockup stored

6. Remove and store marker lockups.

FIELD OPERATION

Planters are designed to operate within a speed range of 3 - 13 km/h. Higher ground speeds can cause more variation in seed spacing. Speeds above 9 km/h are typically not recommended.

NOTICE

Always raise planter out of ground when making sharp turns or backing up.

Normal field planting operation requires use of tractor's hydraulic control to raise and lower planter frame when making field turn arounds. Place hydraulic lever in float position during normal field operation.

NOTICE

Operate row markers in float position to prevent damage to row markers.

Operate row markers with control console switch for that marker in ON (LEFT or RIGHT) position and tractor's hydraulic control. After markers are lowered to ground, move hydraulic control to operate markers in float position. Marker speed is controlled with flow control valves located in planter hitch valve block. One valve controls raise speed and other valve controls lower speed of both markers. See "Row Marker Speed Adjustment" and "Row Marker Operation".

FIELD TO TRANSPORT SEQUENCE

Position planter in a relatively flat open area without furrows, etc.

SUMMARIZED FIELD TO TRANSPORT SEQUENCE

1. Install marker lockups.
2. Raise planter to fully extend master/slave cylinders.
3. Install center (slave) lift cylinder lockups.
4. Lower planter onto center lift cylinder lockups.

NOTICE

Folding planter without using tractor to assist may cause equipment damage especially in soft conditions or when loaded with seed or fertilizer. Use tractor to reduce stress on frame, drive, and transport components.

5. Place tractor in low forward gear and hold in clutch. Start folding planter and move tractor slowly forward as planter folds to keep wing wheel side pressure to a minimum.
6. Raise hitch parallel linkage to engage wing hooks.
7. Install hitch parallel linkage lock pin or lockup bracket.
8. Lower hitch parallel linkage cylinder.

NOTE: Read following information for detailed instructions.

WARNING

Planter hitch may raise uncontrollably during folding/unfolding and can cause death, serious injury, or damage property and equipment. DO NOT fold or unfold planter without planter attached to a tractor. DO NOT unhitch planter from tractor unless fully folded for transport or fully unfolded with planting units lowered to ground.

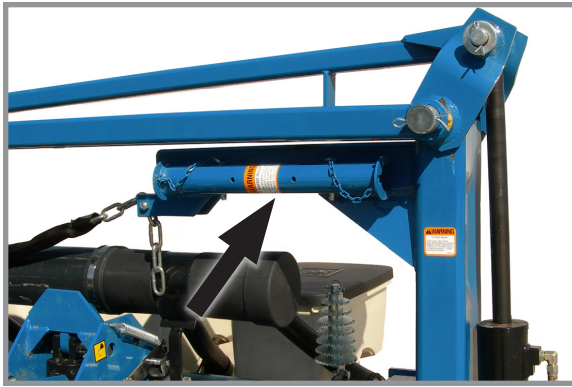

Row marker safety lockup stored



Row marker safety lockup installed

1. Install cylinder lockups on marker cylinders to prevent markers from unfolding when not in use or planter is in transport position.

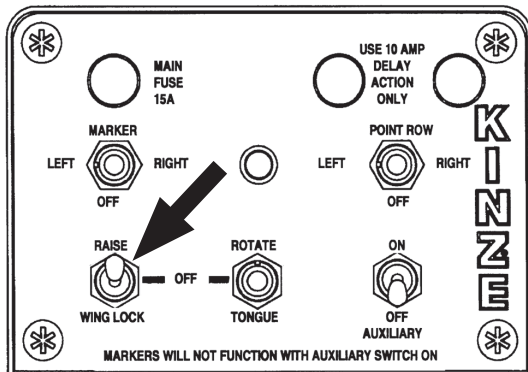

Raising planter

2. Hold RAISE/WING LOCK switch on control console in **RAISE** while operating proper tractor hydraulic control to raise planter. Planter frame should raise level until lift (master) cylinders at ends of wings are fully extended. Center lift (slave) cylinders will continue to extend (at a somewhat slower rate) until they are fully extended.

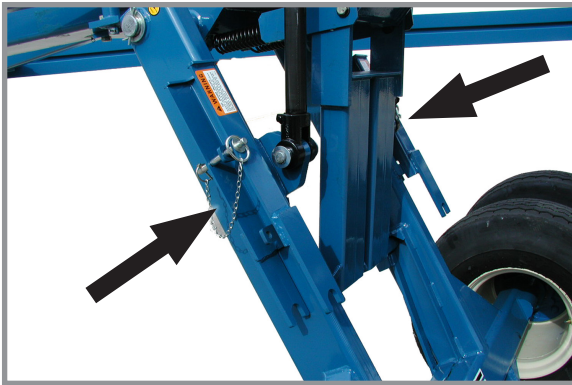

Safety lockups in storage position

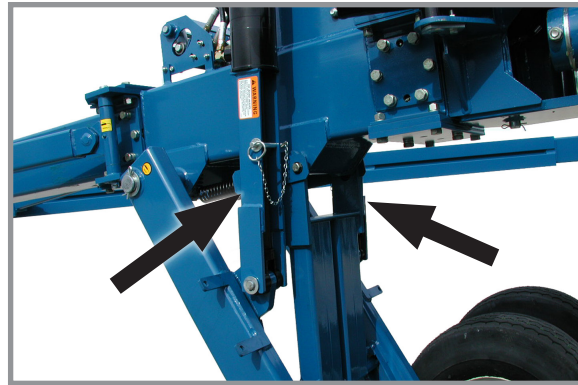

Safety lockups in transport position

NOTICE

DO NOT fold planter into transport position without lift cylinder lockups installed or uncontrolled planter settling can damage equipment.

3. Install center (slave) lift cylinder lockups. Install pin assembly to lock each in place.
4. Lower planter onto center lift (slave) cylinder lockups.

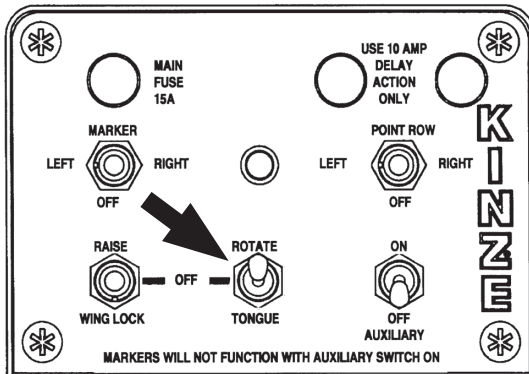

Planter folding

5. Hold **ROTATE/TONGUE** switch in **ROTATE** and operate hydraulic control to fold planter. Slowly idle tractor forward as you fold planter, allowing center axle tires to remain stationary and wing tires to roll in a continuous arc with minimal side loading on tires or their mounting structure. Hooks on wing ends should pass over planter hitch and contact stops on draft links.

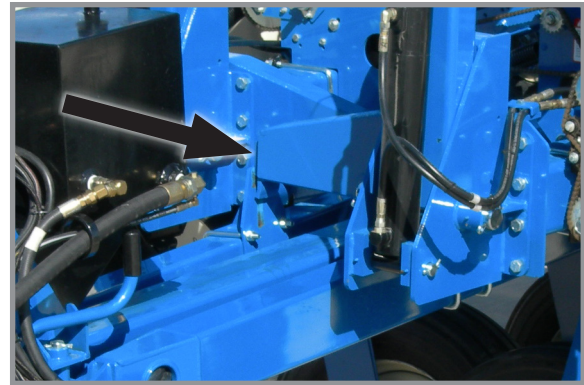
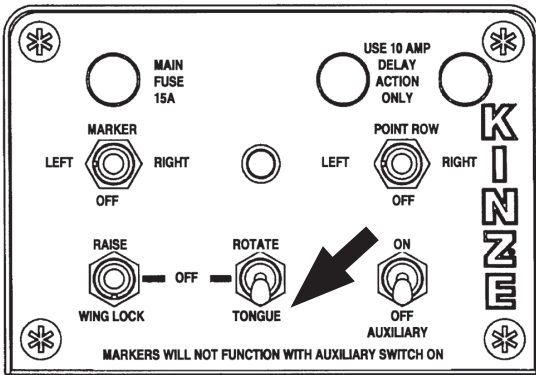

Wing end hook

NOTICE DO NOT LOWER planter frame onto transport axle in folded transport position or transport tires and row units will be damaged.

6. Raise hitch parallel linkage to completely engage wing hooks and completely lift wing wheels off ground.

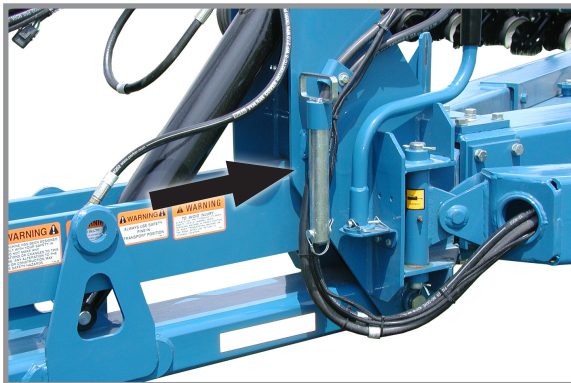

Hitch parallel linkage pin stored

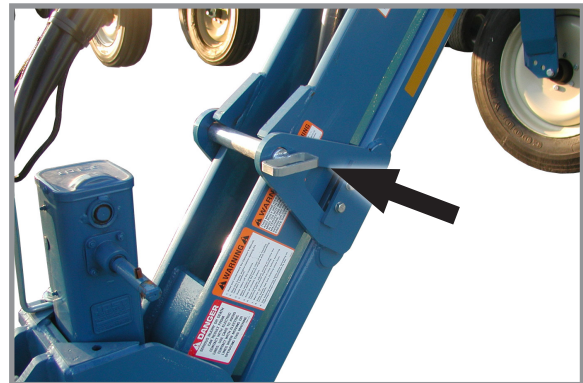

Hitch parallel linkage pin installed

7. Install parallel linkage lock pin.
8. Lower parallel link cylinder onto lock pin.

ROW MARKER OPERATION

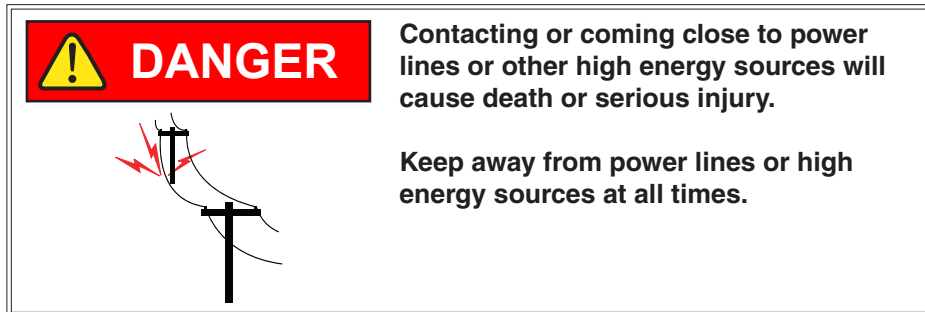

Marker switch

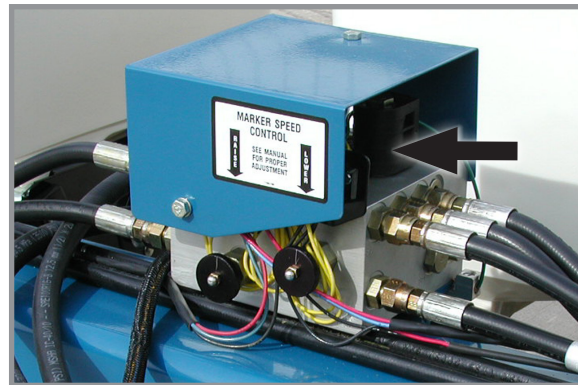

Row marker solenoid valves

Two solenoid valves on valve block at rear R.H. side of center frame, and a three position selector switch on control console permit operator to lower or raise desired row marker.

NOTICE

Marker position switch must be OFF when planter is not in use or tractor battery will drain.

NOTE: See row marker adjustments on following pages.

1. Select which row marker to lower on control console.
2. Operate hydraulic control to lower row marker.
3. Move control switch to other side to operate opposite row marker.
4. Raise row marker at end of field using hydraulic control.
5. After turn, using the hydraulic control, lower the pre-selected row marker.
6. Continue to follow this procedure.

NOTE: Both row markers can be lowered by operating switch in each position and hydraulic control twice. Row markers raise simultaneously with hydraulic control in raise position.

If electrical system does not operate properly:

- Check fuse.
- Check wiring connections.
- Check control switch.
- Check solenoid. SOLENOID HOUSING IS MAGNETIZED WHEN ENERGIZED.

ROW MARKER SPEED ADJUSTMENT

NOTICE

Excessive row marker travel speed can damage row markers. Adjust flow controls before row markers are first used.

Marker hydraulic system includes two flow control valves. One flow control valve sets lowering speed and one sets raising speed of both markers. Flow controls determine amount of oil flow restriction through valves, varying marker travel speed.

Loosen jam nut and turn control clockwise, or IN to slow travel speed. Turn counterclockwise, or OUT to increase travel speed. Tighten jam nut after adjustments are complete.

NOTE: Tractors with flow control valves. Make row marker speed adjustment with tractor flow controls in maximum position. After row marker speed is set, adjust tractor flow controls to allow hydraulic control to stay in detent during marker raise or lower cycle.

NOTE: Hydraulics operate slowly when oil is cold. Make all adjustments with oil warm.

NOTE: On a tractor where oil flow cannot be controlled, tractor flow rate may be greater than rate marker cylinder can accept. Hold tractor hydraulic control lever until cylinder reaches end of its stroke. This occurs most often on tractors with an open center hydraulic system.

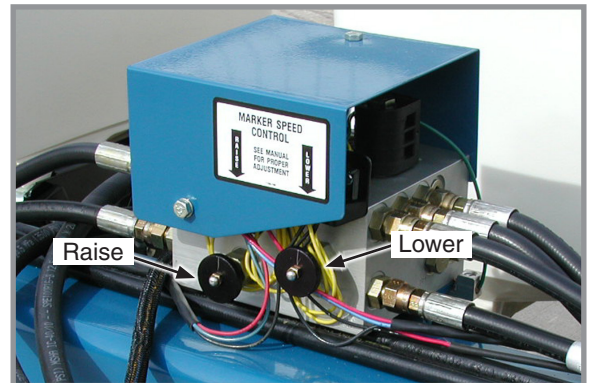

Row marker speed control adjustment

ROW MARKER CHAIN ADJUSTMENT



NOTE: Operate two-fold or three-fold row markers with the tractor's hydraulic valve in float position.

Chain adjustment is critical. Adjust chain with second stage of marker in vertical position and first stage in horizontal position.

Chain must be adjusted so third stage of marker is pulled out as soon as second stage begins outward travel. Chain stretches with use and needs routine adjustment. It may be necessary to twist chain for a finer adjustment.

Marker chain is **PROPERLY ADJUSTED** if marker blade pushes dirt 30 cm or less as marker completes fold into field operating position. Chain should have some slack when marker is in field operating position.

Marker chain is **TOO LOOSE** and should be adjusted if marker blade pushes dirt more than 30 cm as it completes the fold into field operating position.

Marker chain is **TOO TIGHT** if it will not allow marker blade to follow ground contour and chain is tight when marker is in field operating position.

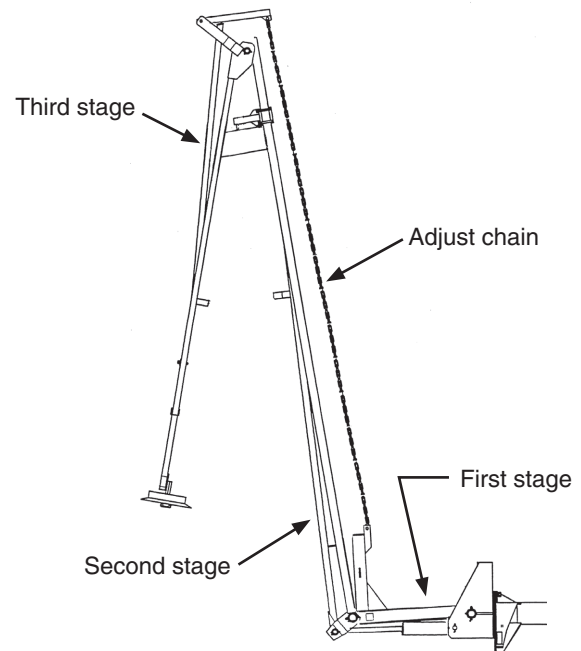

ROW MARKER LENGTH AND DISC BLADE ADJUSTMENT

1. Multiply number of rows by the average row spacing in inches to determine total planting width.

Row Marker Lengths	
24 Row 70 cm	16.80 m

2. Lower planter and row marker assembly to ground.
3. Measure from planter center line to a point where blade contacts ground.
4. Adjust row marker extension so distance from marker disc blade to center line of planter is equal to total planting width. Adjust right and left row marker assemblies equally and securely tighten clamping bolts.

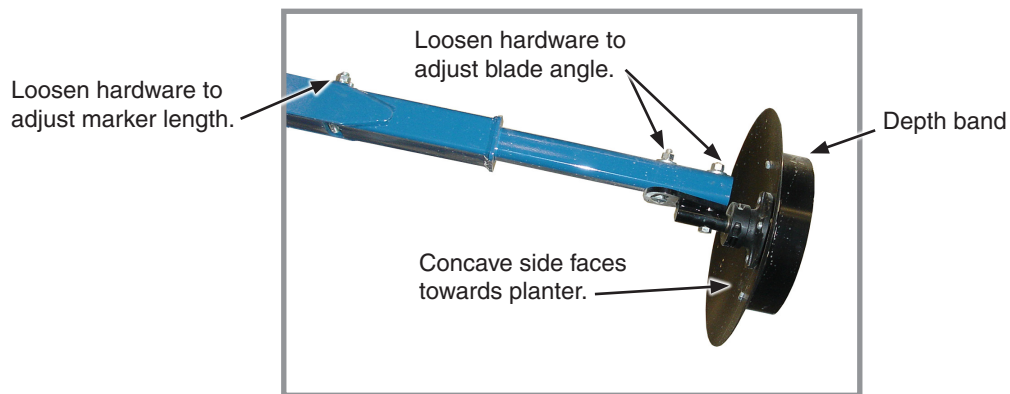

Row marker disc blade angle adjustment

NOTICE

Setting marker disc blade assembly at a sharper angle than needed adds stress to row marker assembly and shortens bearing and blade life. Set blade angle only as needed to leave a clear mark.

Marker disc blade is installed with concave side facing inward. Spindle assembly is slotted so hub and blade can be angled to throw more or less dirt.

5. Loosen hardware and move assembly as required.
6. Tighten bolts to specified torque.
7. Do a field test to ensure markers are properly adjusted.

NOTE: A notched marker blade is available from Kinze through your Kinze Dealer for use in more severe no till conditions.

VACUUM SYSTEM

Kinze vacuum seed metering system includes seed meters, seed discs, and an air system consisting of a hydraulic driven vacuum fan which draws air through manifolds, hoses, and seed meters on each row unit.

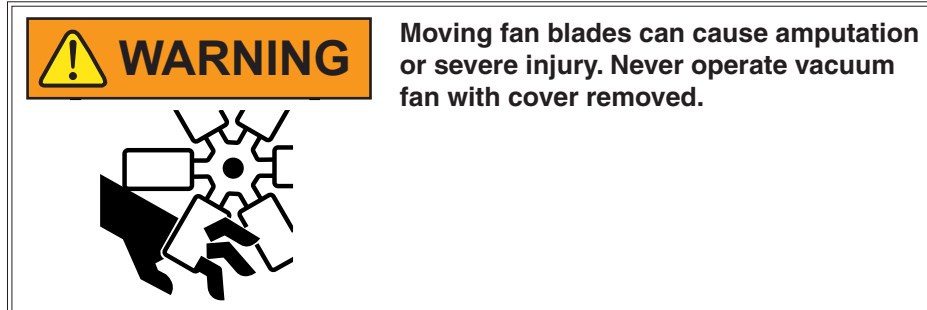

VACUUM FAN VALVE BLOCK ASSEMBLY

A pressure relief valve prevents build up of oil pressure over 35 PSI (241 kPa) in case drain line when vacuum fan motor is operating. This valve vents oils outside through a drain hole in aluminum valve block. This can occur whenever case drain is improperly connected or pressure in motor circuit builds.

Valve block contains a check valve that prevents vacuum fan from operating in wrong direction if pressure is applied to return side of motor and allows fan to coast to a stop when tractor hydraulic control is returned to neutral position.

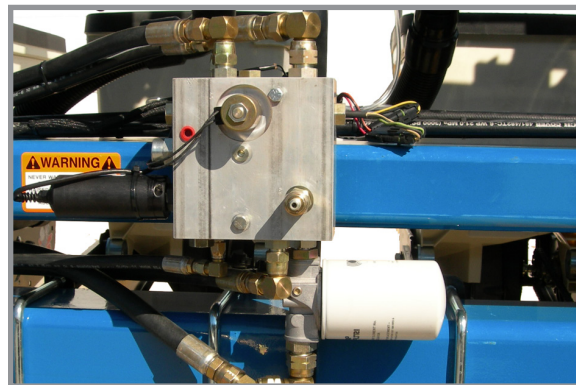

Vacuum fan valve block

See “Hydraulic Schematic (Vacuum Fan System)” in Lubrication and Maintenance section.

NOTE: Fan turns at a reduced speed if reverse pressure is applied.

ANALOG VACUUM OR PRESSURE GAUGE

Analog vacuum or pressure gauge connects directly to vacuum meter (vacuum) or bulk fill (pressure) manifold and is tied into digital sending units.

Only adjustment is to “zero” needle with no vacuum or pressure present. If there is a significant difference between gauge and a reading taken at meters, a different manifold location should be found to connect hose to gauge and digital sending unit.

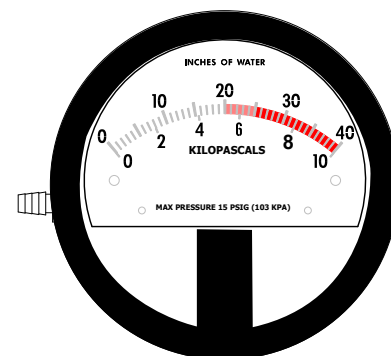

Analog Gauge

NOTE: Analog gauges are identical EXCEPT for plug and hose barb locations in side of gauge housing. DO NOT connect vacuum meter or bulk fill hose to wrong gauge. Check plug and hose barb installation if readout is erratic or appears inaccurate.

AG LEADER INTEGRA DISPLAY

INTEGRA is a full-featured hub of any precision farming operation. A large, full-color 12.1" HD touchscreen display is easy to read and offers powerful, year-round precision farming tools. Mapping, planter and application control, yield monitoring, real-time data logging, and more – are all controlled from the cab using the Integra display.

Four video camera inputs provide operators a better view of equipment operation and safety by allowing them to view live video on the display.

NOTE: See Integra operator manual for installation and programming.



Ag Leader Integra display

AG LEADER MONITORING CONTROL PACKAGE (PMM)

The PMM Magnetic Distance Sensor Package includes a planter-mounted module enclosure with cover and mounting hardware, seed tubes w/sensors, planter harness, planter monitor cable, shaft rotation sensors and magnetic distance sensor components.

Ag Leader Integra display and associated cab harnesses are also required.



Planter monitor module (PMM)

AG LEADER INCOMMAND 1200 DISPLAY

The InCommand 1200 is a full-featured display for any precision farming operation. A large, full-color 12.1" HD touchscreen display is easy to read and offers powerful, year-round precision farming tools. Mapping, planter and application control, yield monitoring, real-time data logging, and more – are all controlled from the cab using the InCommand display.

Four video camera inputs provide operators a better view of equipment operation and safety by allowing them to view live video on the display.

NOTE: See InCommand operator manual for installation and programming.



Ag Leader InCommand Display

POINT ROW CLUTCHES

L.H. point row clutch switch
10 amp time delay fuse

R.H. point row clutch switch
10 amp time delay fuse

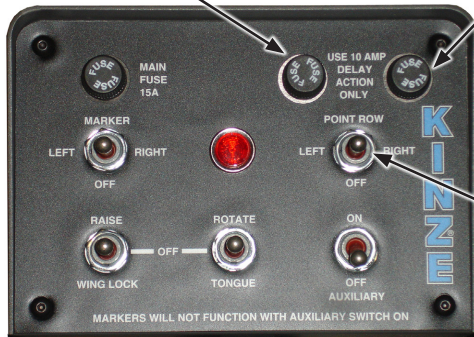

Single point row clutch control box



Point row clutch

Electric-activated clutches disengage drive on either half of planter for finishing up fields or for long point row situations. Clutch selector switch is located on tractor control box.

NOTICE

Switch must be OFF when planter is not in use or tractor battery will be drained.

NOTE: Liquid fertilizer piston pump has its own drive wheel and is not affected by point row clutch.

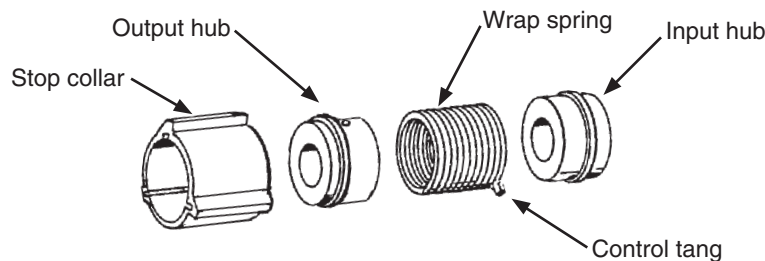

Clutch consists of a wrap spring riding on an input and output hub. Wrap spring is wrapped tightly over hubs during operation locking them together. Higher speeds create a tighter grip of spring on hubs.

Input end of spring is bent outward and is called the control tang. Control tang fits into a slot in stop collar located between input and output hubs over wrap spring. If stop collar is allowed to rotate with input hub, clutch is engaged. If stop collar is stopped from rotating, control tang connected to it is forced back and spring opens. This allows input hub to continue rotating without transmitting torque to output hub, stopping planter drive.

Stop collar is controlled by an electric solenoid and an actuator arm. When selector switch on tractor control box is OFF, solenoid coil is NOT ENERGIZED and actuator arm will not contact stop on stop collar, allowing it to rotate with hubs and drive planter.

When operational switch is in "DISENGAGE" (right or left) solenoid coil IS ENERGIZED and plunger in solenoid coil pulls actuator arm against stop on stop collar, disengaging wrap spring and stopping planter drive.

PISTON PUMP

NOTE: Keep manuals shipped with pump and flow divider with this manual.

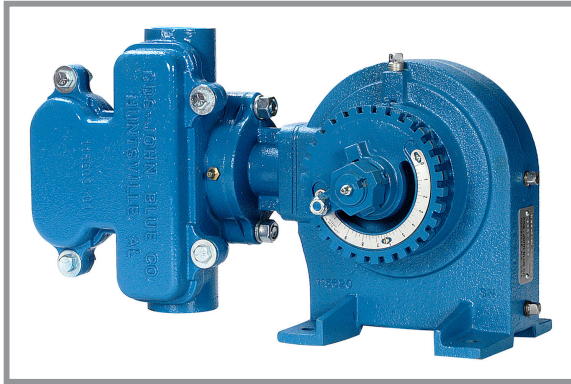

Piston pump

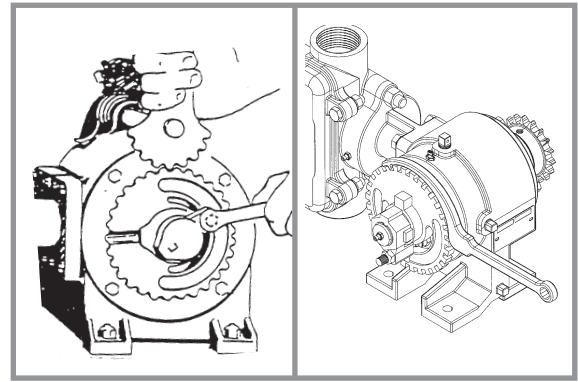

Adjusting delivery rate

NOTE: Delivery rate chart in Rate Chart section of this manual provides approximate application rate only. Delivery varies with temperature and fertilizer.

Loosen $\frac{3}{8}$ " lock nut that secures arm with pointer and rotate scale flange with adjustment wrench until pointer is over desired scale setting. Tighten $\frac{3}{8}$ " lock nut. **DO NOT OVERTIGHTEN.**

NOTE: Periodically check flow to all rows. Set rate is delivered to remaining rows if one or more lines are plugged.

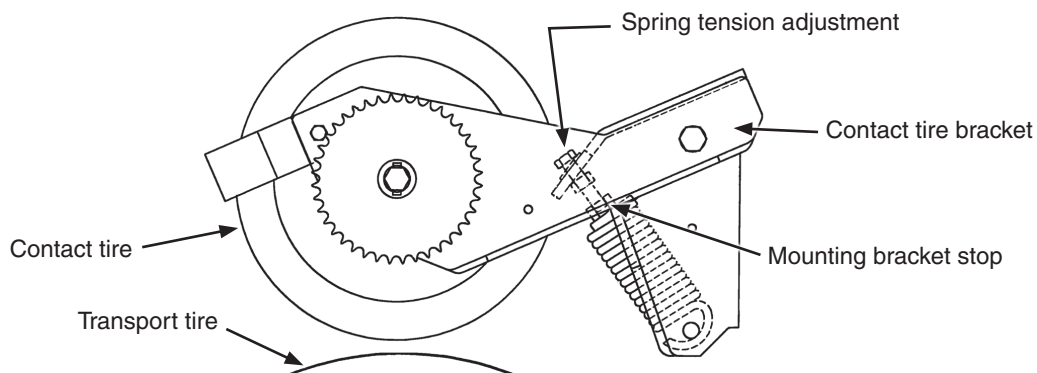

Set piston pump drive spring tension so there is no slack in springs when contact tire bracket is resting on mounting bracket stop. Contact tire and transport tire should not be touching.

CLEANING

Clean tanks, hoses, and metering pump thoroughly with water at end of planting season or prior to an extended period of non-use. Do not allow fertilizer to crystallize from cold temperature or evaporation.

On machines equipped with piston pump, take apart and clean strainer located between piston pump and ball valve daily. Remove the end cap to clean the screen. See Piston Pump Storage in Maintenance Section of this manual.

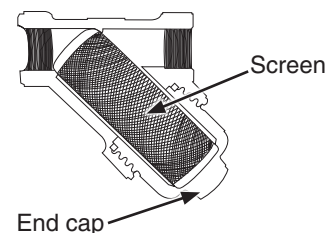

CHECK VALVES



Check valve

Optional low rate check valves are available for in-line installation between liquid fertilizer piston pump and openers to ensure equal distribution of product at low rates. Check valves eliminate anti-siphon loops.

LOW-RATE (POP-UP) LIQUID FERTILIZER SYSTEM

Check flow out of each row frequently to ensure orifices have not been plugged.

If fluid is allowed to sit in the lines overnight and the temperature drops below 0 Celsius it is recommended that the orifices be removed and the lines be flushed before continuing operations. Many fertilizers can salt out in temperatures under 0 Celsius and clog orifices.

REAR TRAILER HITCH (24 ROW 70 CM ONLY)



Trailer hitch



Hitch position during lift

Rear trailer hitch is used to tow a 3 or 4 wheel wagon behind planter. Hitch height during field operation and transport is 38 cm. Hitch height will raise to approximately 107 cm when planter is lifted.

NOTICE

Rear trailer hitch is designed for use with piston pump only. Maximum allowable hitch weight is 200 lb (91 kg). Do not exceed 6000 lb (2.7 tons) gross towing weight or the equivalent of a loaded 500 gal (1893 L) tank and running gear or equipment can be damaged.

NOTE: Periodically check feed hose for kinks to prevent restricted delivery rate.

Adjust rear trailer hitch length by loosening the 5/8" set screws at rear of outer tube, removing 1" x 8 1/2" bolt at center of hitch, and sliding hitch in or out to one of 4 sets of adjustment holes. Reinstall and tighten hardware.

FIELD TEST

Perform a field test with any change of field and/or planting conditions, seed size or planter adjustment to ensure proper seed placement and operation of row units.

- Check planter for front to rear and lateral level operation. See “Level Planter”.
- Check **all** row units to be certain they are running level. Row unit parallel arms should be approximately parallel to the ground when planting.
- Check row markers for proper operation and adjustment. See “Row Marker Speed Adjustment”, “Row Marker Chain Adjustment”, and “Row Marker Length and Disc Blade Adjustment”.
- Check for proper application rates and placement of granular chemicals on **all** rows. See “Field Check Granular Chemical Application”.
- Check for desired depth placement and seed population on **all** rows. See “Field Check Seed Population”.
- Check for proper application rates of fertilizer on **all** rows. See “Fertilizer Application Rate Chart”.

Reinspect machine after field testing.

- Hoses And Fittings
- Bolts And Nuts
- Cotter Pins And Spring Pins
- Drive Chain Alignment

FIELD CHECK SEED POPULATION

1. Tie up one or more sets of closing wheels by running a chain or rubber tarp strap between the hopper support panel and closing wheels. It may be necessary to decrease closing wheel arm spring tension.

Chain, rubber tarp strap, or similar.

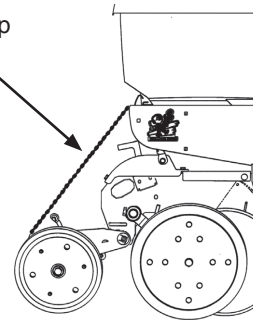

2. Plant a short distance and check to see if seed is visible in the seed trench. Adjust planting depth to a shallower setting if seed is not visible and recheck.

Planting depth adjustment handle

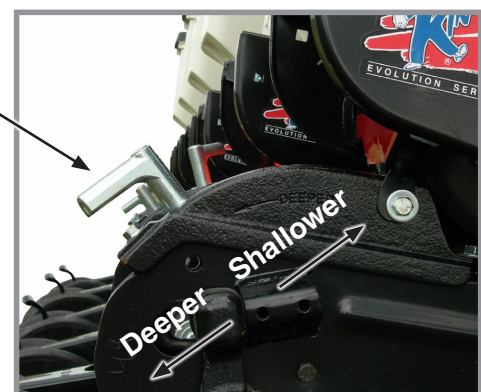

Planting depth adjustment

3. Measure $\frac{1}{1000}$ of an hectare. See chart for correct distance for row width being planted. For example, if planting 76 cm rows $\frac{1}{1000}$ of an hectare would be 14.28 m.

$\frac{1}{1000}$ Acre Seed Population Count Row Width/Distance	
Row Width	70 cm
Distance	14.28 m

NOTE: Seeds may bounce or roll when planting with closing wheels raised and planting depth set shallow affecting seed spacing accuracy.

4. Count seeds in measured distance.
5. Multiply number of seeds placed in $\frac{1}{1000}$ of an hectare by 1000. This gives total population.

EXAMPLE: 70 cm row spacing 14.28 m equals $\frac{1}{1000}$ hectare.

75 seeds counted x 1000 = 75,000 seeds per hectare

Seed count can be affected by drive wheel and seed meter drive ratio, tire pressure, and/or seed meter malfunction.

1. If seed check shows average distance between seeds in inches is significantly different than seed rate chart indicates, first check drive ratio between drive wheel and seed meter. Check drive wheel air pressure, check for incorrect sprocket(s) in driveline and check drive and driven sprockets on transmission(s) for proper selection.
2. Check for seed meter malfunction. "Vacuum Seed Meter" on page 6-5.

DETERMINING LITERS PER HECTARE

Kilograms per hectare ÷ Seed unit weight = Liters per hectare

Average Unit Weight of:

- 1 Liter Soybeans = 1.90 Kilograms
- 1 Liter Milo/Grain Sorghum = 1.78 Kilograms
- 1 Liter Cotton = 1.01 Kilograms

If seed population check shows planting rate is significantly different than seed rate chart shows or if a particular meter is not planting accurately, "Vacuum Seed Meter" on page 6-5

FIELD CHECK GRANULAR CHEMICAL APPLICATION

Temperature, humidity, speed, ground conditions, flowability of different material, or meter obstructions can affect granular chemical rate of delivery.



WARNING

Agricultural chemicals can cause death or serious injury to persons, animals, and plants or seriously damage soil, equipment, or property. Read and follow all chemical and equipment manufacturers labels and instructions.

Perform a field check to determine application rates.

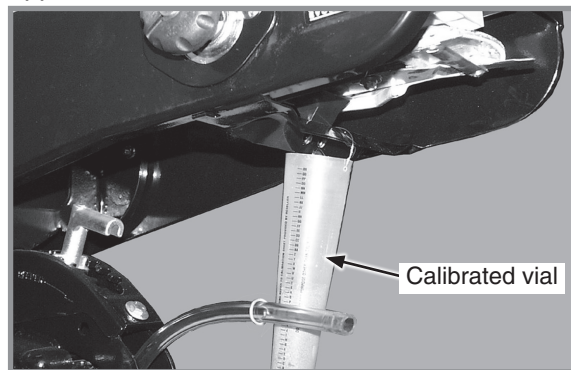

Granular chemical field check

1. Fill insecticide and/or herbicide hoppers.
2. Attach a calibrated vial to each granular chemical meter.

NOTE: Disengage clutch to avoid dropping seed during test.

3. Lower planter and drive 400 meters at planting speed.
4. Weigh chemical in ounces caught in one vial.
5. Multiply that amount by factor shown to determine pounds (kilograms) per acre (hectare).

Pounds (Kg) Per Acre (Hectares)	
Row Width	Factor
70 cm	0.0357

EXAMPLE: You are planting 70 cm rows. You have planted for 400 meters at desired planting speed. You caught 337 grams of chemical in one vial. 337 grams times 0.0357 equals 12 kilograms per hectare.

NOTE: Check calibration of all rows.

METERING GATE

Use metering gate setting as a starting point for distributing insecticide or herbicide. Charts are based on 8 km/h planting speed. Use a higher gate setting for speeds faster than 8 km/h and a lower setting for speeds slower than 8 km/h.

WATER TANK

The water tank is to only be filled with clean water or preferably potable water (water meeting local standards for drinking). The tank holds 15 L of water. Be sure to check for regulations pertaining to this use. Tank should be filled with new water at the beginning of each planting season and drained at the end of each planting season.

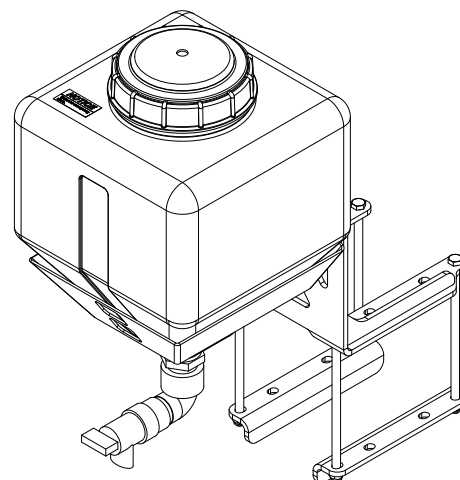

NOTICE

Drain tank if environmental conditions are 0° Celsius or below to prevent tank from cracking.

The water tank is to be used in the event of an accidental exposure to chemical. Chemicals are supplied with Material Safety Data Sheets (MSDS) that provide full information about the chemical, its effects on exposure, and first aid needs in the event of an emergency. Keep your MSDS file up-to-date and available for first responders in case of emergency.

If the water tank is used seek medical assistance immediately for further treatment.

PLANTING DEPTH

Planting depth is maintained by adjustable row unit gauge wheels. Depth adjustment range is approximately 1.2 to 8.9 cm).

1. Raise planter to remove weight from wheels.
2. Push down on depth adjustment handle and reposition it forward to decrease or rearward to increase planting depth. Initially adjust all units to the same setting.
3. Lower planter and check operation and planting depth of all row units. Readjust individual rows as needed for uniform operation.



Planting depth adjustment

“V” CLOSING WHEEL ADJUSTMENT (RUBBER OR CAST IRON)

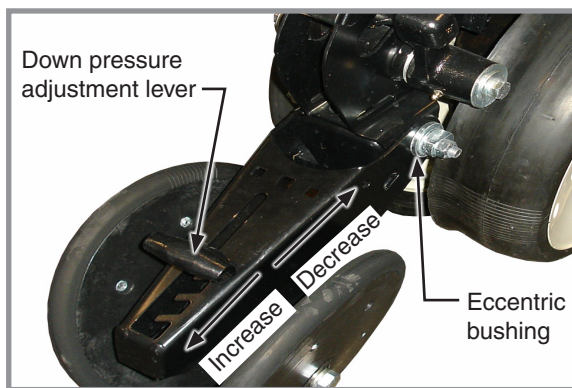

“V” Closing wheel adjustments

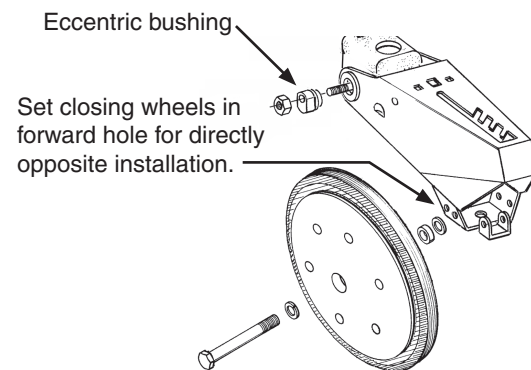

“V” closing wheels should have enough down pressure to close the seed trench and ensure good soil to seed contact. Move 5-position quick adjustable down force lever on the top of closing wheel arm to the rear to increase closing wheel spring pressure. Move lever forward to decrease pressure. Adjust all row units to a similar setting. Light soil usually requires less down force at average depth, approximately 5 cm, while heavy soil requires increased down force.

Eccentric bushings in the wheel arm stop allow for lateral adjustment of the “V” closing wheel assembly. Use a $\frac{3}{4}$ " wrench to loosen hardware attaching closing wheel arm to wheel arm stop. Use another $\frac{3}{4}$ " wrench to turn eccentric bushings until **closing wheels are aligned with seed trench**. Tighten hardware.

Closing wheels can be installed “offset” (to improve residue flow) or “directly” opposite. Use forward installation holes if set “directly” opposite.

CLOSING WHEEL SHIELD (RUBBER OR CAST IRON “V” CLOSING WHEELS)

Optional closing wheel shield is installed on underside of closing wheel arm to help prevent root balls and stalks from clogging closing wheels.

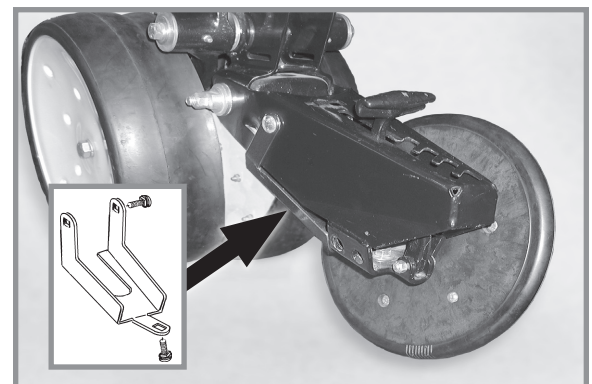

Closing wheel shield (Closing wheel removed)

DRAG CLOSING ATTACHMENT

Drag closing attachment pulls loose soil over seed trench.

NOTE: Use of a seed firming wheel or other seed firming device is recommended with drag closing attachment.

Front and rear adjustment is made using slotted holes in blades. Adjust all rows the same. Wheel arm stop eccentric bushings provide lateral adjustment. Use a $\frac{3}{4}$ " wrench to loosen closing wheel arm to wheel arm stop hardware. Use another $\frac{3}{4}$ " wrench to turn eccentric bushings until drag closing attachment is aligned with seed trench. Tighten hardware.

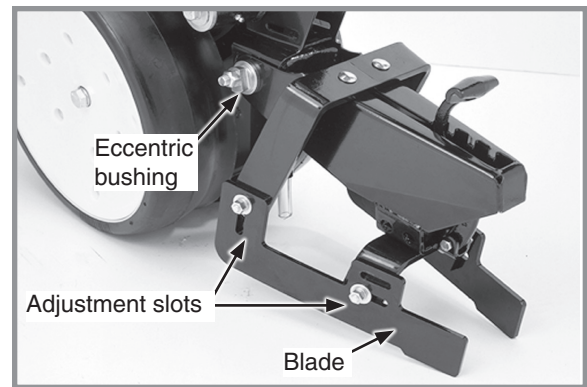

Drag closing attachment

ROW UNIT EXTENSION BRACKETS

Row unit extension brackets extend row units rearward 4" (10.1 cm) to provide clearance for coulter mounted residue wheels and HD single disc fertilizer openers.

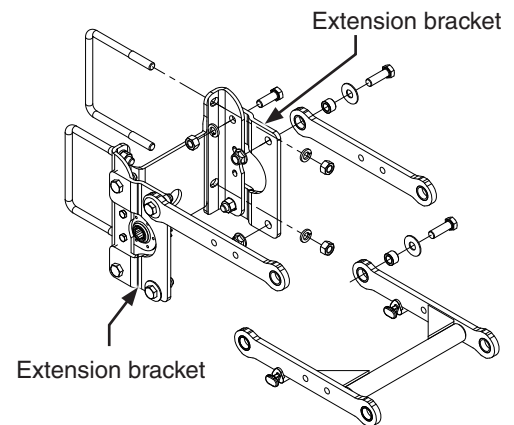

Row unit extension brackets

SEED HOPPERS

Vacuum seed hopper has a capacity of 62 L.

Use clean seed and make certain there are no foreign objects inside when filling seed hopper. **Replace hopper lids after hoppers are filled to prevent accumulation of dust or dirt in seed meter which can cause premature wear.**

Periodically empty hoppers completely to remove any foreign objects and to ensure proper seed meter operation. Disengage meter drive and hopper latch and lift hopper off hopper support. See "Seed Meter Drive Release".

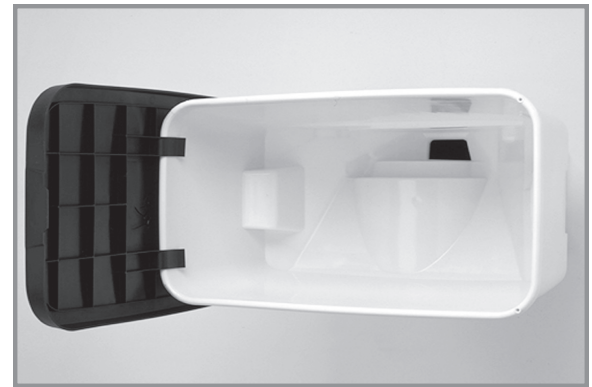

Seed Hopper

SEED METER DRIVE RELEASE

A clutch release mechanism disengages seed meter drive from seed meter to remove seed hopper or prevent meter from operating. Releasing drive allows operator to check granular chemical application rates without dropping seed. It also allows one or more rows to be disconnected when finishing fields.

Turn knob $\frac{1}{4}$ turn counterclockwise to release or $\frac{1}{4}$ turn clockwise to engage drive.

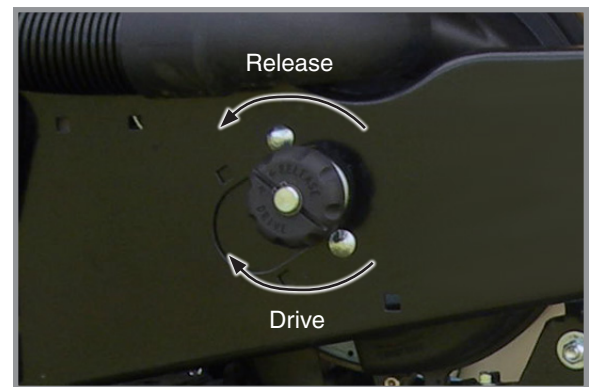

Seed meter drive release

ROW UNIT CHAIN ROUTING

Row unit drive chains must be properly tensioned and aligned for proper operation and to minimize wear.

Inspect and replace weak, worn or broken springs, idlers, and idler bushings.

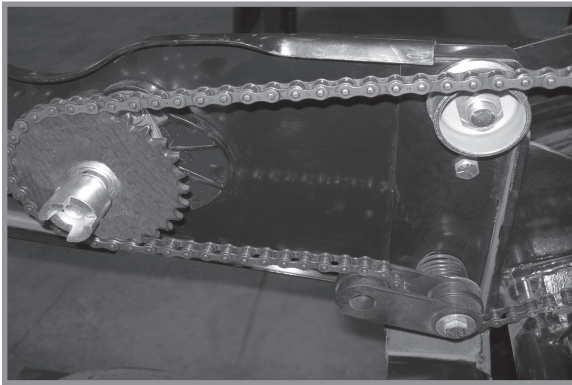

Vacuum pull row unit meter drive

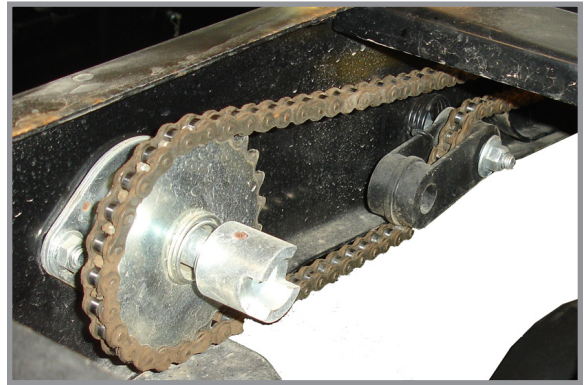

Row unit granular chemical drive

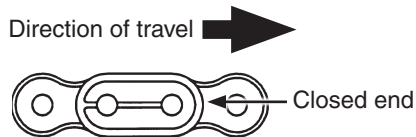

NOTE: Install connector link with closed end facing direction of travel.

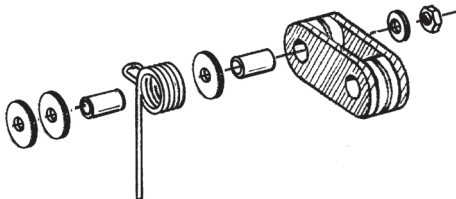

NOTE: Reverse idler when worn on one side for extended use.

QUICK ADJUSTABLE DOWN FORCE SPRINGS OPTION

Quick adjustable down force springs increase penetration in hard soil and keep row unit from bouncing in rough field conditions. Two springs per row, one on each side parallel arms, are used unless equipped with row unit mounted no till coulters. Four springs per row are used with row unit mounted no till coulters.

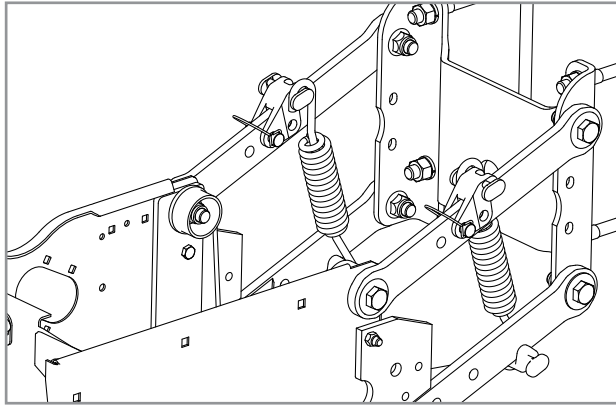

Two Springs Per Row (Dual)

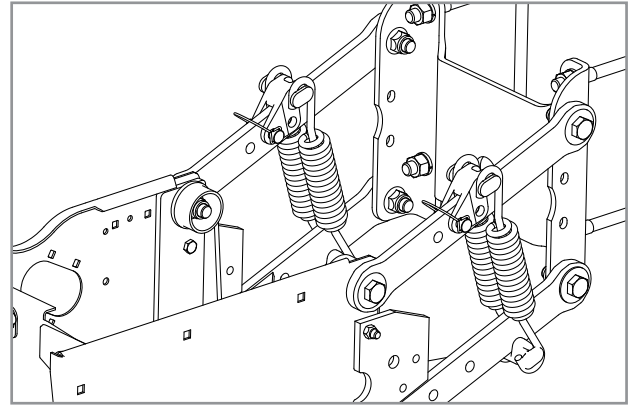

**Four Springs Per Row (Quad)
(Row Unit Mounted No Till Coulters Only)**

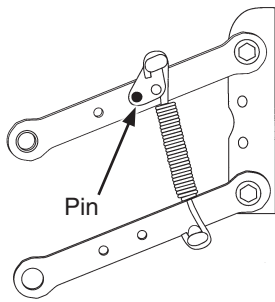

Position 1 (Least)

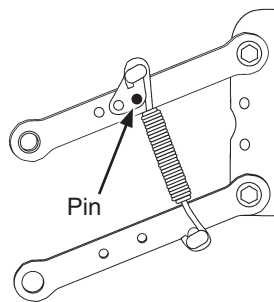

Position 2

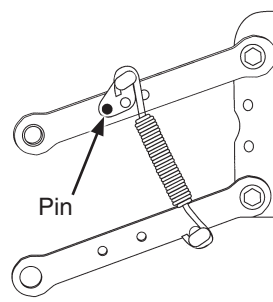

Position 3

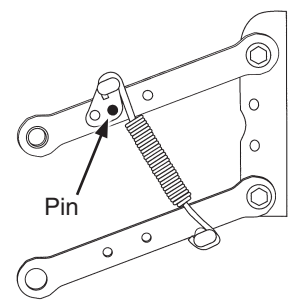

Position 4 (Most)

There are four positions to set down pressure spring tension.

NOTICE	Springs must be installed with open side of spring hooks toward seed hoppers to prevent binding on spring mount adjustment pins.
---------------	---

1. Raise planter and remove spring mount pin at top of spring.
2. Slide mount to desired position and install pin.

NOTE: Adjust springs for field conditions. Too much down pressure in hard field conditions can cause row units to lift planter and keep drive wheels from making contact. Too much down pressure in soft field conditions can cause row unit to run too deep.

Heavy Duty Spring Down Force Pressure*		
	2 Springs	4 Springs
Position	Heavy Duty P/N: D21337	Heavy Duty P/N: D21337
1	43 lb (19.5 kg)	80 lb (36.3 kg)
2	86 lb (39.0 kg)	144 lb (65.3 kg)
3	167 lb (75.7 kg)	307 lb (139.3 kg)
4	249 lb (113.0 kg)	470 lb (213.2 kg)

*Pressure does not include weight of row unit, seed, or options.

PNEUMATIC DOWN PRESSURE (PDP)

Row unit down pressure can be adjusted on-the-go as field conditions change. A cab-mounted control box adjusts pressure (Older models may have a digital readout). Two planter-mounted 12 VDC air compressors with 3 gallon capacity air tank supplies air for the down pressure system. Maximum downforce provided by PDP is ~218 kg/row.

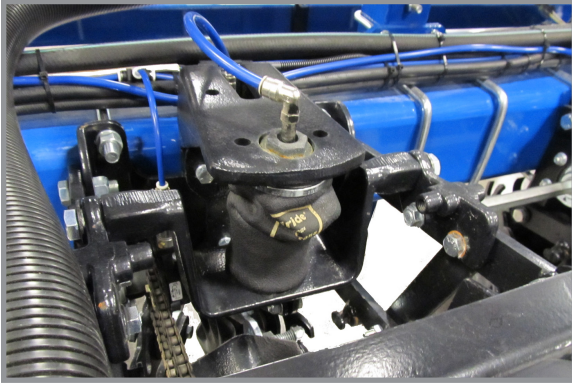

Pull row unit air spring

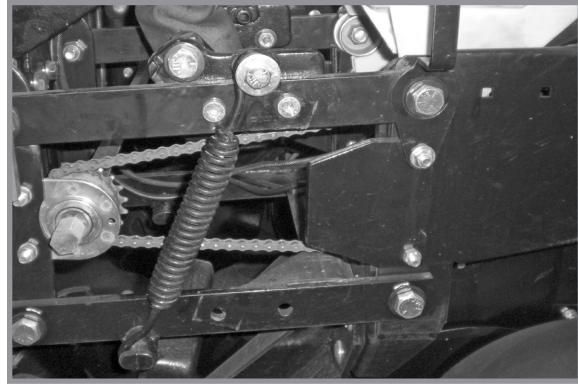

Pull row unit assist springs

Packages include upper and lower air spring mounting castings for pull row units, 150 PSI (1034 kPa) rated air springs, $\frac{3}{8}$ " O.D. nylon hoses, dual solenoid air valve and stainless steel, 160 PSI (1103 kPa), 2" liquid-filled gauge and planter wiring harness.

Pneumatic down pressure row unit extension brackets are required in some applications.

NOTE: Assist springs are available through your Kinze dealer if additional down pressure is needed. One spring is installed on outer side of parallel arms on each side of row unit.

FIELD OPERATION

NOTE: Adjust down pressure with planter lowered and row openers in ground for most accurate adjustment. Pressure can be adjusted from tractor using control console, or at planter using manual control valves on compressor assembly.



Control console

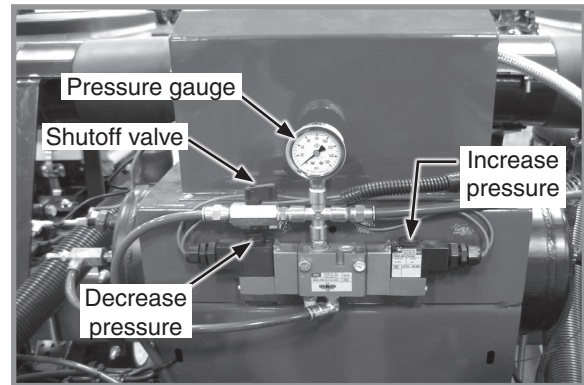

Air compressor assembly controls

ADJUST DOWN PRESSURE FROM CAB









Push toggle switch left to increase or right to decrease pressure.

ADJUST DOWN PRESSURE AT PLANTER

Push and hold decrease or increase button on compressor assembly to decrease or increase pressure.

NOTE: Value on the air pressure gauge is NOT down pressure force. Multiply air pressure (PSI) by four (4) to calculate down pressure (lbs).

VACUUM SETTINGS

Crop		**Seed Disc Kit	Seed Disc Part No.	Ejector Wheel (Color)	Cells	Seed Size Range	Singulator Zone Setting	Vacuum Setting Inches of Water (cm)	Lubricant
	Corn ‡ Large Sweet Corn	G11043X	B1219 (Light Blue)	1 row 5 punches (Light Blue)	40	35-70 lbs/80k (2500-5000 seeds/kg)	2	18-20 (46-51)	Graphite* Talc*
	Soybean	G11047X	B1232 (Black)	2 rows 6 punches (Black)	120	2200-4000 seeds/lb (4850-8820 seeds/kg)	0	10-14 (25-36)	Graphite* Talc*
	Sugar Beet	G11045X	B1229 (Dark Orange)	1 row 6 punches (Dark Orange)	60	Pelletized	2	15 (38)	Graphite*
	Milo	G11045X	B1229 (Dark Orange)	1 row 6 punches (Dark Orange)	60	10,000-20,000 seeds/lb (22000-44000 seeds/kg)	2	15 (38)	Graphite* Talc*
	Sunflower ‡ Small Sweet Corn	1044X	B1230 (Gray)	1 row 5 punches (Gray)	40	Oil seeds #2, 3, 4	2	12-18 (30-46)	Graphite* Talc*
	Sunflower	G11044X	B1230 (Gray)	1 row 5 punches (Gray)	40	Oil seeds #5	2	5-8 (13-20)	Graphite* Talc*
	Specialty Disc 1	G11039X	B1233 (Green)	1 row 6 punches (Green)	60	Cotton	2	15-20 (37-50)	Graphite* Talc as needed*
	Specialty Disc 2	G11040X	B1235 (Brown)	1 row 6 punches (Green)	60	Black turtle & navy edible beans	2	15-20 (38-51)	Graphite* Talc as needed*
	Specialty Disc 3	G11041X	B1234 (Dark Blue)	1 row 6 punches (Green)	60	Pinto & Great Northern edible beans & low-rate soybean	2	15-20 (38-51)	Graphite* Talc as needed*

Install selected seed disc. Position vacuum cover on meter by aligning keyhole slots over bolt heads. Push cover on meter and turn counter clockwise to lock in place.

*For More information on application rate, see Additives section.

**Includes seed disc, ejector wheel, and spring.

‡Conventional hoppers only, not applicable with bulk fill.

NOTE: See [“Field Check Seed Population” on page 2-38](#) for more information. Always field check seed population to ensure planting rates are correct.

NOTE: Singulator settings are marked from 0 - 3.

NOTE: Mixing seed sizes and shapes affects meter performance. Use consistent seed size and shape.

NOTE: Use 1 tablespoon powdered graphite with each standard hopper fill of seed. Seed treatment, foreign material, dirt or seed chaff may cause gradual reduction of seed disc fill (population). See “Additives” pages for more information.

NOTE: Excessive seed treatment, humidity, and light-weight seed can affect meter performance. Use 118 ml of talc with each standard hopper fill of seed and mix thoroughly to coat all seeds and adjust rates as needed. Use of talc aids seed flow into meter, singulation, and disc seed drop.

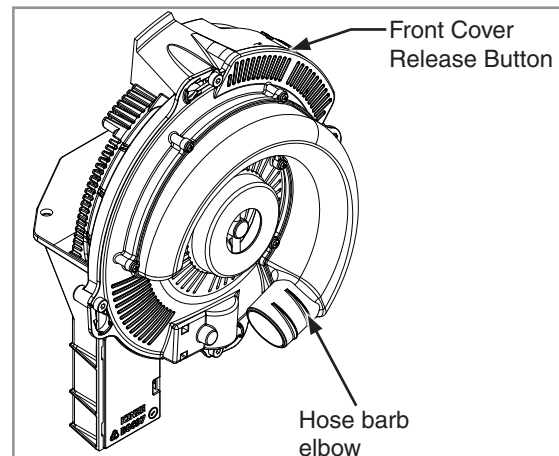
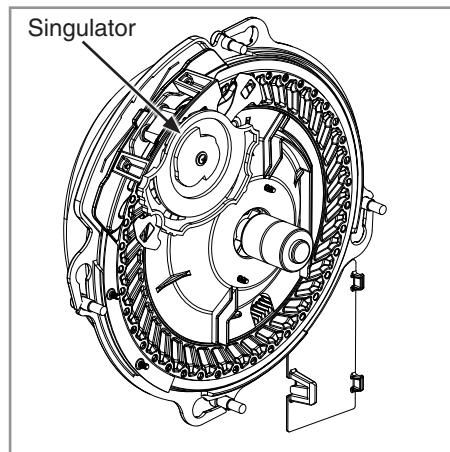

NOTE: Foreign material in seed disc orifices, such as seed chips, hulls, stems, etc., may affect seed delivery. Clean seed ensures accurate seed metering from vacuum seed meter. Remove Seed discs daily to check for buildup of foreign material in seed disc orifices.

Air inlet screens allow air to enter system and aids in keeping field residue or other foreign material out of meter.

See [“Vacuum Seed Meter Maintenance” on page 5-13](#) and [“Preparation for Storage” on page 5-32](#) in Lubrication and Maintenance section for more information.

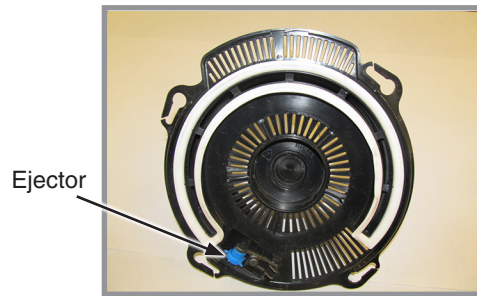

NOTE: Damaged seed or seed containing foreign material will cause plugging of seed disc orifices and require more frequent seed meter cleanout to prevent underplanting.

Wheel-Type Ejectors

Wheel-type ejectors expel seed remnants from seed disc orifices. These ejectors are disc specific and colored coded to match disc.

NOTICE	Replace hopper or tank lids after filling to prevent accumulation of dust or dirt in seed meter resulting in premature wear.
---------------	---

NOTE: Seed size, seed shape, seed treatments, travel speed, and planting rate affect meter performance.

1. Select seed disc and ejector to match crop and population.

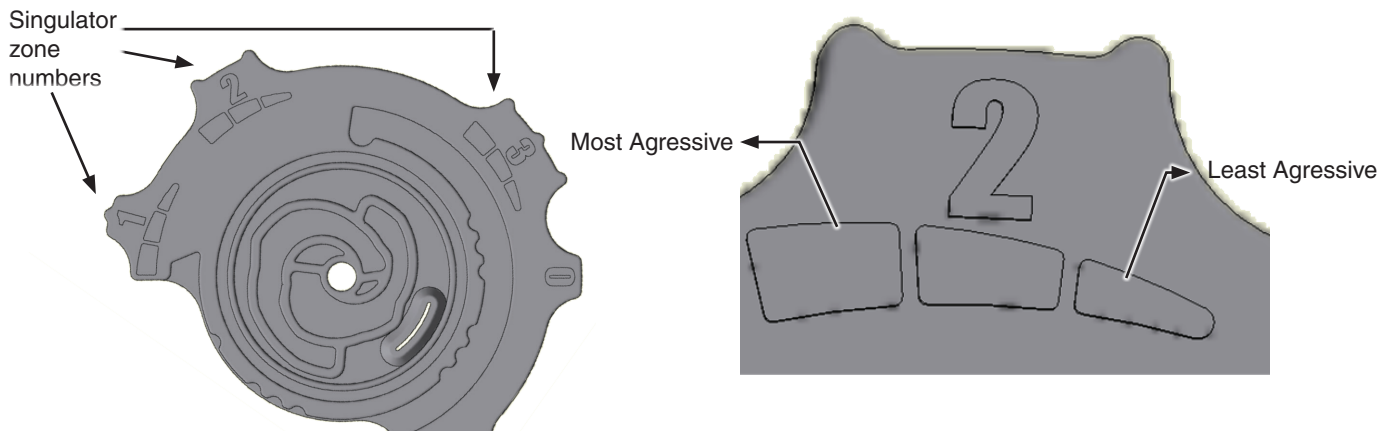

Singulator Adjustment Wheel

2. Adjust singulator wheel to initial setting. Seed size, seed shape, seed treatments, travel speed and planting rate all affect meter performance.
3. With vacuum fan running, lower planter to planting position and drive forward a short distance to load seed into seed disc cells.
4. Adjust vacuum level to initial setting according to tables on page.

NOTE: Vacuum reading will be much lower when seed disc cells are empty. Load all seed cells before setting vacuum level.

NOTE: Operate vacuum fan 3-5 minutes to bring oil up to normal operating temperature prior to making final vacuum level adjustment.

SEED METER CLEANOUT

NOTE: Use of damaged seed or seed containing foreign material will cause plugging of seed cell orifices and require more frequent seed meter cleanout to prevent underplanting.

Thorough seed meter cleanout is important to maintain genetic purity.

1. Disengage seed drive and remove seed hopper and meter.
2. Dump seed from right rear corner of hopper into a container.
3. Lay hopper on its right side. Push release button and rotate seed meter vacuum cover clockwise to align keyhole slots with bolt heads. Lift off cover.
4. Rotate seed disc hub clockwise to unlock and remove seed disc.
5. Empty meter.
6. Thoroughly inspect meter to ensure all seed is removed.
7. Replace seed disc. Install vacuum cover.

ADDITIVES

GRAPHITE

The use of graphite is recommended to promote seed flow, provide lubrication for the seed meter and to help dissipate static charge buildup. Among the available dry seed lubricants graphite is the most effective and easiest to use and it requires no mechanical agitation

CONVENTIONAL HOPPERS

Mix one tablespoon of **powdered graphite** with seed each time hoppers are filled. Regular graphite use prolongs life of the seed meter components, improves seed spacing, and may reduce buildup of seed treatments.

NOTE: DO NOT apply graphite only in center of hopper. It will filter too quickly through the seed and not distribute as evenly as desired.

Apply graphite around outer perimeter of hopper.

NOTE: Additional graphite may be required to retard buildup of seed treatments on meter components. More frequent cleaning of monitor seed tubes may be necessary due to use of additional graphite.

80/20 TALC-GRAPHITE

Talc-Graphite lubricant is to be used for treated seed, providing benefits of both talc and graphite. It absorbs moisture to prevent bridging, minimizes static electricity for improved seed flow, and lubricates seed and meters.

Conventional Hoppers

Mix ½ C. of 80/20 talc-graphite evenly with seed each time hoppers are filled. Regular graphite use prolongs life of the seed meter components, improves seed spacing, and may reduce buildup of seed treatments.

NOTE: Talc-Graphite lubricant MUST be mixed evenly during fill.

TALC

Talc seed lubricant may be used as a drying agent in addition to graphite lubrication. The drying agent may improve seed release and/or **to retard buildup of seed treatments on meter components.**

1. Fill hopper ½ full of seed, add ¼ cup (conventional) of talc and **mix thoroughly**.
2. Finish filling hopper, add another ¼ cup (conventional) of talc and **mix thoroughly**.
3. Adjust rate of talc use as needed so all seeds are coated, while avoiding a buildup of talc in bottom of hopper.

Humid conditions and/or small sized seeds with extra seed treatment may require additional talc to maintain meter performance.

NOTE: Liquid seed treatments or inoculants may create buildup on the seed disc or brushes. Check frequently for proper population and/or seed delivery when using any liquid seed treatment.

Completely mix all treatments with seed following manufacturers' recommendations. Seed treatment dumped on top of seed after hopper is filled may not mix properly and cause seed bridging, reducing population or stopping meter from planting.

Lubricant Application Rate	
Graphite	
Conventional Hoppers	1 Tbs. (~15 ml)/Hopper Fill
80/20 Talc-Graphite	
Conventional Hoppers	1/2 C (120 ml).**
**Must be evenly mixed during fill.	
Talc	
Conventional Hoppers	¼" C. (~59 ml*)
*Double amount of talc for sunflowers.	



Adding graphite to conventional hopper

ROW UNIT MOUNTED RESIDUE WHEEL

Row unit mounted residue wheels are used on pull and push row units.

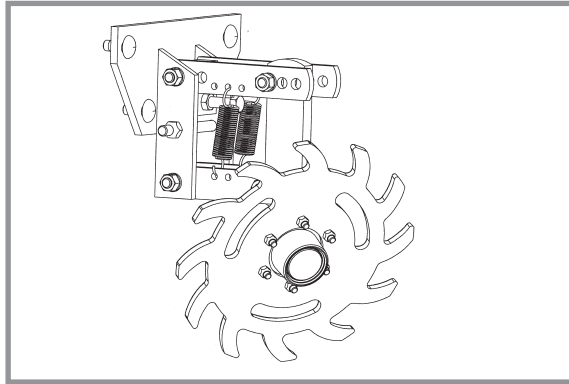

Row Unit Mounted Residue Wheel

Two adjustable springs on each residue wheel parallel links provide down force adjustment. Position 1 provides minimum down pressure and position 3 maximum down pressure.

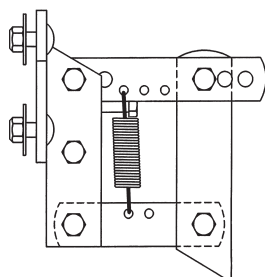

Position 1 (Least)

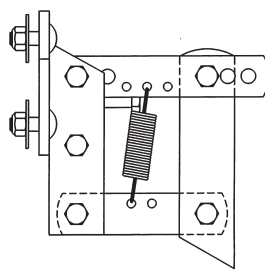

Position 2

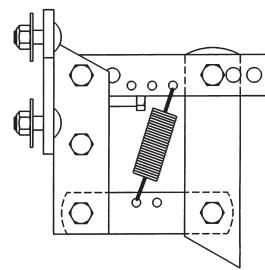

Position 3 (Most)

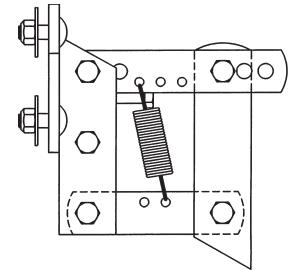

Additional uplift or float

Raise row unit and reposition springs to adjust down pressure.

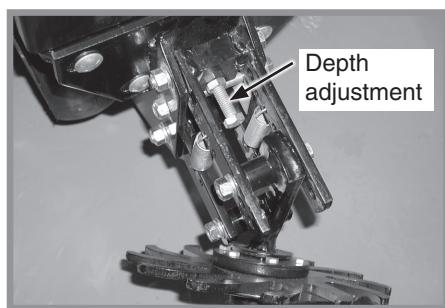

Wheel depth adjustment

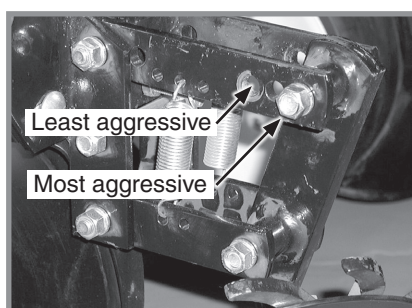

Wheel angle adjustment

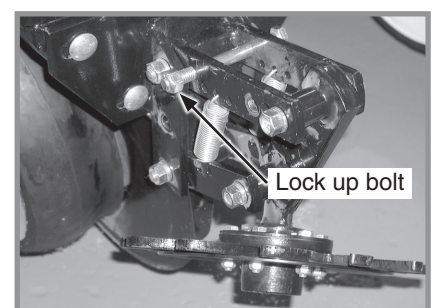

Wheel lock up

A full threaded bolt and jam nut located on the upper link sets maximum depth for loose soil conditions. Initial setting is 1 $\frac{3}{4}$ " (45 mm) above row unit double disc opener depth.

Three holes in upper link adjust wheel angle. With wheel mount in most vertical position, using the rear hole in the upper link, the residue wheel is most aggressive. Moving wheel mount to a forward hole reduces aggressiveness of residue wheel for use in mulch till applications where soil is loose.

To lock residue wheel up, remove 1/2" x 5" lockup bolt, raise residue wheel and install bolt.

SPIKED CLOSING WHEEL

Spiked closing wheels crumble the sidewall, allowing roots to penetrate soil. They can be used on pull row units and push row units.

Align spiked closing wheels straight across from each other, in most rearward holes on closing wheel arm. Set the wheels 1" - 1¼" (25 - 31 mm) apart at the closest point. If large amounts of contouring is being done, mount wheels in the forward most hole. This will reduce drifting of row unit.

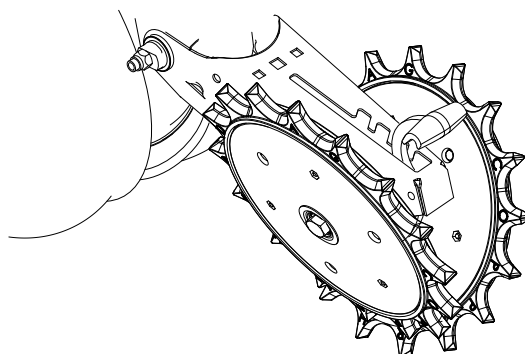

Row Unit Spiked Closing Wheel

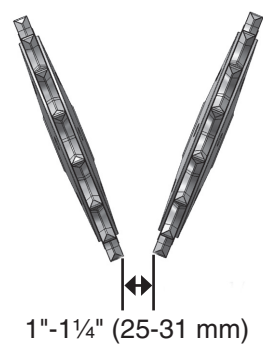

ROW UNIT MOUNTED NO TILL COULTER

Row unit mounted no till coulters with 1" bubbled, 1" fluted (8 flutes) or 3/4" fluted (13 flutes) blades may be used on pull row units and push row units (3/4" fluted shown). Four quick adjustable down force springs are required per row when using row unit mounted no till coulters. See "Quick Adjustable Down Force Springs Options".

Align coulters to row unit double disc openers. Adjust by loosening four attaching bolts, moving coulters, and tightening four attaching bolts. Coulters can be adjusted to one of four 13mm incremental settings in the forked arm. Initial location is the top hole.

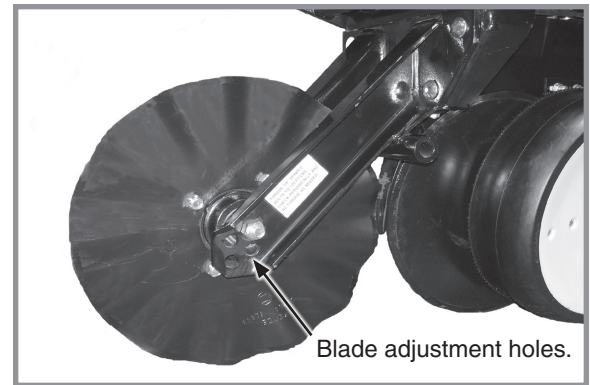

Row Unit Mounted No Till Coulters

Move blade as it wears to one of the three lower holes to maintain coulters at or slightly above opener discs as needed. Adjust coulters below depth of double disc opener blades in very hard soil conditions such as compacted wheel tracks to improve opener penetration and cutting of surface residue.

Check operating depth by setting planter down on a level concrete floor and checking relationship between coulters and row unit opener blades. Make sure planter is level and coulters are square with planter frame and aligned with row unit disc opener.

NOTE: Torque 5/8" spindle hardware to 163 Nm.

COULTER MOUNTED RESIDUE WHEELS

Coulters mounted residue wheels are designed for use on pull row units and push row units. Row unit extension brackets are required on the four center pull row units if the planter is equipped with coulters mounted residue wheels.

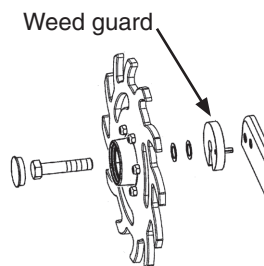

NOTE: Opening in weed guard must face down.



Coulters mounted residue wheels

Residue wheels attach to row unit mounted coulters with two cap screws and sleeves allowing unit to free-float. A 2-position spindle bolt mounting positions wheels interlocked or staggered. Depth adjustment is made with a spring-loaded cam and pin with 11 positions in 6 mm increments. A high point on the cam allows wheels to be locked up.

A weed guard on the inboard side of each wheel helps prevent weed wrap which can cause premature bearing failure.

GRANULAR CHEMICAL HOPPER AND DRIVE



WARNING

Agricultural chemicals can cause death or serious injury to persons, animals, and plants or seriously damage soil, equipment, or property. Read and follow all chemical and equipment manufacturers labels and instructions.

The granular chemical hopper has a 40 L cubic feet capacity.

Make sure no foreign objects get into hopper when it is being filled. Replace hopper lids after filling to prevent accumulation of dirt and moisture.

A metering gate on bottom of hopper regulates the application rate. See “Dry Insecticide and Dry Herbicide Application Rate Charts” in this manual. Calibrate using chemical manufacturers’ instructions.



Granular chemical hopper

Granular chemical clutch drive coupler and meter shaft can be disengaged and engaged by turning throwout knob at rear of hopper support panel.

Rotate knob $\frac{1}{4}$ turn counterclockwise to disengage and $\frac{1}{4}$ turn clockwise to engage.

Slotted holes in hopper support panel and clutch housing allow for alignment adjustment between clutch drive coupler and meter shaft.

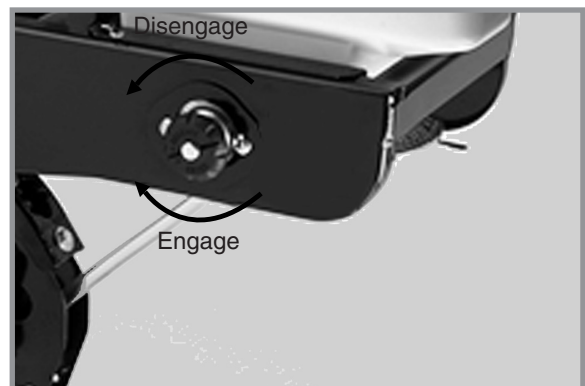

Granular chemical drive release

GRANULAR CHEMICAL BANDING OPTIONS

Granular chemical banding options allow 4½" (115 mm) slope-compensating banding or straight drop in-furrow placement.

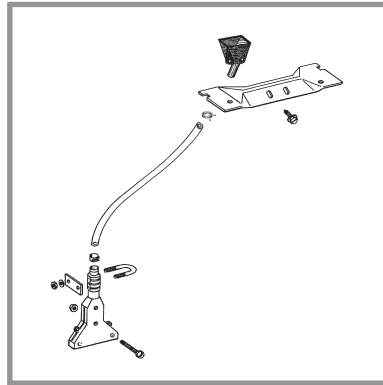

4½" (115 mm) slope-compensating bander

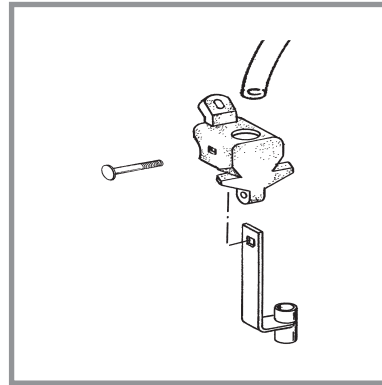

Straight drop in-furrow placement

GRANULAR CHEMICAL BANDER SHIELD

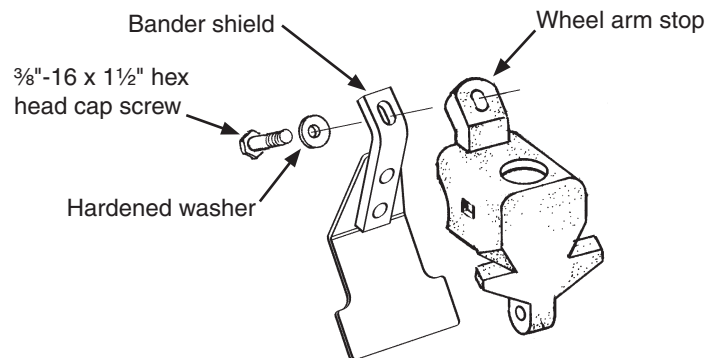

Optional granular chemical bander shield is installed on underside of wheel arm stop to shield crop residue from lodging in granular chemical bander.

GENERAL PLANTING RATE INFORMATION**NOTICE**

Sprocket combinations in these charts are for average conditions. Changes in sprocket combinations may be required for desired planting population. **ALWAYS MAKE FIELD CHECKS TO BE SURE YOU ARE PLANTING AT DESIRED RATE.**

NOTE: Seed size and shape may affect planting rate.

NOTE: Speeds above 9 km/h can adversely affect seed spacing.

NOTE: Planting speed can affect actual seeding rate. Make a field check and adjust transmission setting to obtain desired seed drop.

NOTE: Contact wheel drive sprocket references are located in each chart title.

NOTE: 22, 28 and 44 tooth drive sprockets are NOT applicable to all rate charts. Check chart titles to ensure proper rate chart is selected. 22 tooth sprockets require use of 148 pitch No. 40 chains, 28 tooth sprockets require use of 150 pitch No. 40 chains and 44 tooth sprockets require use of 158 pitch No. 40 chains.

NOTE: 30 tooth sprockets are not standard with the model 3705 planter. See your authorized Kinze dealer.

**VACUUM PLANTING RATES FOR CORN / SUNFLOWER 40 CELL DISC
15 TOOTH CONTACT WHEEL DRIVE SPROCKET
APPROXIMATE SEEDS / HECTARE FOR 70 CM ROWS**

70 cm Rows	Transmission Sprockets		Recomm. Speed Range (km/h)	Average Seed Spacing (cm)
	Drive	Driven		
40747	15	30*	6 to 10	35.1
43657	15	28	6 to 10	32.7
45274	15	27	6 to 10	31.6
47014	15	26	6 to 10	30.4
48895	15	25	6 to 10	29.2
49478	17	28	6 to 10	28.9
50934	15	24	6 to 10	28.0
51310	17	27	6 to 10	27.8
53147	15	23	6 to 10	26.9
53285	17	26	6 to 10	26.8
55299	19	28	6 to 10	25.8
55415	17	25	6 to 10	25.8
57346	19	27	6 to 10	24.9
57723	17	24	6 to 10	24.7
59552	19	26	6 to 10	24.0
60233	17	23	6 to 10	23.7
61935	19	25	6 to 10	23.1
64337	15	19	6 to 10	22.2
64515	19	24	6 to 10	22.1
66941	23	28	6 to 10	21.3
67321	19	23	6 to 10	21.2
69419	23	27	6 to 10	20.6
69852	24	28	6 to 10	20.5
71904	15	17	6 to 10	19.9
72437	24	27	6 to 10	19.7
72916	17	19	6 to 10	19.6
74973	23	25	6 to 10	19.1
75673	26	28	6 to 10	18.9
78096	23	24	6 to 10	18.3
78234	24	25	6 to 10	18.3
78583	27	28	6 to 10	18.2
81494	23	23	6 to 10	17.5
84512	28	27	6 to 10	16.9
84628	27	26	6 to 10	16.9
85036	24	23	6 to 10	16.8
87761	28	26	6 to 10	16.3
88011	27	25	6 to 10	16.2
88579	25	23	6 to 10	16.1
91081	19	17	6 to 10	15.7
91680	27	24	6 to 10	15.6
92122	26	23	6 to 10	15.5
95075	28	24	6 to 10	15.0
95664	27	23	6 to 10	14.9
98650	23	19	6 to 10	14.5
99210	28	23	6 to 10	14.4
102938	24	19	6 to 10	13.9
107228	25	19	6 to 10	13.3
110254	23	17	6 to 10	13.0
111516	26	19	6 to 10	12.8
115048	24	17	6 to 10	12.4
115806	27	19	6 to 10	12.3
119841	25	17	6 to 10	11.9
120094	28	19	6 to 10	11.9
124637	26	17	6 to 10	11.5
124955	23	15	6 to 10	11.4
129431	27	17	6 to 10	11.0

NOTE: See “General Planting Rate Information” and “Checking Seed Population” (located in operator’s manual) pages for additional information. Always check seed population in the field to ensure planting rates are correct.

**VACUUM PLANTING RATES FOR CORN /SUNFLOWER 40 CELL DISC
22 TOOTH CONTACT WHEEL DRIVE SPROCKET
APPROXIMATE SEEDS / HECTARE FOR 70 CM ROWS**

70 cm Rows	Transmission Sprockets		Recomm. Speed Range (km/h)	Average Seed Spacing (cm)
	Drive	Driven		
59762	15	30*	6 to 10	23.9
64031	15	28	6 to 10	22.3
66401	15	27	6 to 10	21.5
68956	15	26	6 to 10	20.7
71716	15	25	6 to 10	19.9
72566	17	28	6 to 10	19.7
74702	15	24	6 to 10	19.1
75253	17	27	6 to 10	19.0
77948	15	23	6 to 10	18.3
78148	17	26	6 to 10	18.3
81106	19	28	6 to 10	17.6
81276	17	25	6 to 10	17.6
84108	19	27	6 to 10	17.0
84662	17	24	6 to 10	16.9
87344	19	26	6 to 10	16.4
88342	17	23	6 to 10	16.2
90836	19	25	6 to 10	15.7
94360	15	19	6 to 10	15.1
94621	19	24	6 to 10	15.1
98179	23	28	6 to 10	14.6
98736	19	23	6 to 10	14.5
101816	23	27	6 to 10	14.0
102448	24	28	6 to 10	13.9
105461	15	17	6 to 10	13.5
106241	24	27	6 to 10	13.4
106943	17	19	6 to 10	13.4
109961	23	25	6 to 10	13.0
110983	26	28	6 to 10	12.9
114545	23	24	6 to 10	12.5
114741	24	25	6 to 10	12.5
115255	27	28	6 to 10	12.4
119524	23	23	6 to 10	12.0
123949	28	27	6 to 10	11.5
124121	27	26	6 to 10	11.5
124718	24	23	6 to 10	11.5
128715	28	26	6 to 10	11.1
129086	27	25	6 to 10	11.1
129915	25	23	6 to 10	11.0
133587	19	17	6 to 10	10.7
134464	27	24	6 to 10	10.6
135115	26	23	6 to 10	10.6
139443	28	24	6 to 10	10.2
140309	27	23	6 to 10	10.2
144685	23	19	6 to 10	9.9
145506	28	23	6 to 10	9.8
150977	24	19	6 to 10	9.5
157269	25	19	6 to 10	9.1
161707	23	17	6 to 10	8.8
163558	26	19	6 to 10	8.7
168739	24	17	6 to 10	8.5
169850	27	19	6 to 10	8.4
175770	25	17	6 to 10	8.1
176139	28	19	6 to 10	8.1
182799	26	17	6 to 10	7.8
183267	23	15	6 to 10	7.8
189830	27	17	6 to 10	7.5

NOTE: See "General Planting Rate Information" and "Check Seed Population" pages for more information. Always field check seed population to verify planting rates.

**VACUUM PLANTING RATES FOR CORN / SUNFLOWER 40 CELL DISC
28 TOOTH CONTACT WHEEL DRIVE SPROCKET
APPROXIMATE SEEDS / HECTARE FOR 70 CM ROWS**

70 cm Rows	Transmission Sprockets		Recomm. Speed Range (km/h)	Average Seed Spacing (cm)
	Drive	Driven		
76058	15	30*	6 to 10	18.8
81491	15	28	6 to 10	17.5
84509	15	27	6 to 10	16.9
87761	15	26	6 to 10	16.3
91272	15	25	6 to 10	15.7
92358	17	28	6 to 10	15.5
95075	15	24	6 to 10	15.0
95780	17	27	6 to 10	14.9
99210	15	23	6 to 10	14.4
99462	17	26	6 to 10	14.4
103223	19	28	6 to 10	13.8
103441	17	25	6 to 10	13.8
107048	19	27	6 to 10	13.3
107750	17	24	6 to 10	13.3
111164	19	26	6 to 10	12.9
112436	17	23	6 to 10	12.7
115610	19	25	6 to 10	12.4
120094	15	19	6 to 10	11.9
120428	19	24	6 to 10	11.9
124955	23	28	6 to 10	11.4
125665	19	23	6 to 10	11.4
129584	23	27	6 to 10	11.0
130388	24	28	6 to 10	11.0
134222	15	17	6 to 10	10.6
135220	24	27	6 to 10	10.6
136107	17	19	6 to 10	10.5
139951	23	25	6 to 10	10.2
141256	26	28	6 to 10	10.1
145783	23	24	6 to 10	9.8
146036	24	25	6 to 10	9.8
146687	27	28	6 to 10	9.7
152120	23	23	6 to 10	9.4
157753	28	27	6 to 10	9.1
157971	27	26	6 to 10	9.0
158732	24	23	6 to 10	9.0
163824	28	26	6 to 10	8.7
164289	27	25	6 to 10	8.7
165349	25	23	6 to 10	8.6
170016	19	17	6 to 10	8.4
171135	27	24	6 to 10	8.3
171961	26	23	6 to 10	8.3
177473	28	24	6 to 10	8.0
178576	27	23	6 to 10	8.0
184144	23	19	6 to 10	7.8
185190	28	23	6 to 10	7.7
192152	24	19	6 to 10	7.4
200157	25	19	6 to 10	7.1
205811	23	17	6 to 10	6.9
208165	26	19	6 to 10	6.9
214758	24	17	6 to 10	6.7
216170	27	19	6 to 10	6.6
223707	25	17	6 to 10	6.4
224175	28	19	6 to 10	6.4
232654	26	17	6 to 10	6.1
233251	23	15	6 to 10	6.1
241600	27	17	6 to 10	5.9

NOTE: See “General Planting Rate Information” and “Check Seed Population” pages for more information. Always field check seed population to verify planting rates.

**VACUUM PLANTING RATES FOR SUGAR BEET / MILO / SPECIALTY 60 CELL DISC
15 TOOTH CONTACT WHEEL DRIVE SPROCKET
APPROXIMATE SEEDS / HECTARE FOR 70 CM ROWS**

70 cm Rows	Transmission Sprockets		Recomm. Speed Range (km/h)	Average Seed Spacing (cm)
	Drive	Driven		
61120	15	30*	6 to 10	23.4
65486	15	28	6 to 10	21.8
67910	15	27	6 to 10	21.0
70522	15	26	6 to 10	20.3
73343	15	25	6 to 10	19.5
74218	17	28	6 to 10	19.2
76399	15	24	6 to 10	18.7
76967	17	27	6 to 10	18.6
79721	15	23	6 to 10	17.9
79926	17	26	6 to 10	17.9
82949	19	28	6 to 10	17.2
83124	17	25	6 to 10	17.2
86021	19	27	6 to 10	16.6
86586	17	24	6 to 10	16.5
89330	19	26	6 to 10	16.0
90352	17	23	6 to 10	15.8
92902	19	25	6 to 10	15.4
96504	15	19	6 to 10	14.8
96773	19	24	6 to 10	14.8
100412	23	28	6 to 10	14.2
100980	19	23	6 to 10	14.1
104129	23	27	6 to 10	13.7
104778	24	28	6 to 10	13.6
107858	15	17	6 to 10	13.2
108657	24	27	6 to 10	13.1
109372	17	19	6 to 10	13.1
112460	23	25	6 to 10	12.7
113509	26	28	6 to 10	12.6
117146	23	24	6 to 10	12.2
117350	24	25	6 to 10	12.2
117872	27	28	6 to 10	12.1
122238	23	23	6 to 10	11.7
126768	28	27	6 to 10	11.3
126940	27	26	6 to 10	11.3
127553	24	23	6 to 10	11.2
131642	28	26	6 to 10	10.9
132019	27	25	6 to 10	10.8
132869	25	23	6 to 10	10.8
136621	19	17	6 to 10	10.5
137519	27	24	6 to 10	10.4
138184	26	23	6 to 10	10.3
142611	28	24	6 to 10	10.0
143499	27	23	6 to 10	10.0
147975	23	19	6 to 10	9.7
148812	28	23	6 to 10	9.6
154407	24	19	6 to 10	9.3
160841	25	19	6 to 10	8.9
165382	23	17	6 to 10	8.6
167275	26	19	6 to 10	8.5
172572	24	17	6 to 10	8.3
173710	27	19	6 to 10	8.2
179765	25	17	6 to 10	7.9
180141	28	19	6 to 10	7.9
186955	26	17	6 to 10	7.6
187434	23	15	6 to 10	7.6
194145	27	17	6 to 10	7.4

NOTE: See "General Planting Rate Information" and "Checking Seed Population" (located in operator's manual) pages for additional information. Always check seed population in the field to ensure planting rates are correct.

VACUUM PLANTING RATES FOR MILO/SUGAR BEET/SPECIALTY 60 CELL DISCS
22 TOOTH CONTACT WHEEL DRIVE SPROCKET
APPROXIMATE SEEDS / HECTARE FOR 70 CM ROWS

70 cm Rows	Transmission Sprockets		Recomm. Speed Range (km/h)	Average Seed Spacing (cm)
	Drive	Driven		
89643	15	30*	6 to 10	15.9
96046	15	28	6 to 10	14.9
99602	15	27	6 to 10	14.3
103433	15	26	6 to 10	13.8
107570	15	25	6 to 10	13.3
108850	17	28	6 to 10	13.1
112054	15	24	6 to 10	12.7
112882	17	27	6 to 10	12.7
116925	15	23	6 to 10	12.2
117224	17	26	6 to 10	12.2
121657	19	28	6 to 10	11.7
121912	17	25	6 to 10	11.7
126163	19	27	6 to 10	11.3
126994	17	24	6 to 10	11.2
131015	19	26	6 to 10	10.9
132513	17	23	6 to 10	10.8
136255	19	25	6 to 10	10.5
141541	15	19	6 to 10	10.1
141934	19	24	6 to 10	10.1
147270	23	28	6 to 10	9.7
148104	19	23	6 to 10	9.6
152723	23	27	6 to 10	9.4
153672	24	28	6 to 10	9.3
158191	15	17	6 to 10	9.0
159364	24	27	6 to 10	9.0
160413	17	19	6 to 10	8.9
164940	23	25	6 to 10	8.7
166479	26	28	6 to 10	8.6
171813	23	24	6 to 10	8.3
172114	24	25	6 to 10	8.3
172881	27	28	6 to 10	8.3
179286	23	23	6 to 10	8.0
185924	28	27	6 to 10	7.7
186180	27	26	6 to 10	7.7
187078	24	23	6 to 10	7.6
193077	28	26	6 to 10	7.4
193628	27	25	6 to 10	7.4
194874	25	23	6 to 10	7.3
200377	19	17	6 to 10	7.1
201695	27	24	6 to 10	7.1
202669	26	23	6 to 10	7.0
209165	28	24	6 to 10	6.8
210465	27	23	6 to 10	6.8
217028	23	19	6 to 10	6.6
218260	28	23	6 to 10	6.5
226464	24	19	6 to 10	6.3
235900	25	19	6 to 10	6.1
242561	23	17	6 to 10	5.9
245337	26	19	6 to 10	5.8
253108	24	17	6 to 10	5.6
254773	27	19	6 to 10	5.6
263652	25	17	6 to 10	5.4
264209	28	19	6 to 10	5.4
274200	26	17	6 to 10	5.2
274902	23	15	6 to 10	5.2
284747	27	17	6 to 10	5.0

NOTE: See "General Planting Rate Information" and "Check Seed Population" pages for more information. Always field check seed population to verify planting rates.

VACUUM PLANTING RATES FOR MILO/SUGAR BEET/SPECIALTY 60 CELL DISCS
28 TOOTH CONTACT WHEEL DRIVE SPROCKET
APPROXIMATE SEEDS / HECTARE FOR 70 CM ROWS

70 cm Rows	Transmission Sprockets		Recomm. Speed Range (km/h)	Average Seed Spacing (cm)
	Drive	Driven		
114091	15	30*	6 to 10	12.5
122241	15	28	6 to 10	11.7
126768	15	27	6 to 10	11.3
131642	15	26	6 to 10	10.9
136909	15	25	6 to 10	10.4
138539	17	28	6 to 10	10.3
142611	15	24	6 to 10	10.0
143669	17	27	6 to 10	9.9
148814	15	23	6 to 10	9.6
149194	17	26	6 to 10	9.6
154837	19	28	6 to 10	9.2
155163	17	25	6 to 10	9.2
160572	19	27	6 to 10	8.9
161626	17	24	6 to 10	8.8
166748	19	26	6 to 10	8.6
168655	17	23	6 to 10	8.5
173416	19	25	6 to 10	8.2
180141	15	19	6 to 10	7.9
180641	19	24	6 to 10	7.9
187434	23	28	6 to 10	7.6
188496	19	23	6 to 10	7.6
194376	23	27	6 to 10	7.3
195584	24	28	6 to 10	7.3
201335	15	17	6 to 10	7.1
202828	24	27	6 to 10	7.0
204162	17	19	6 to 10	7.0
209927	23	25	6 to 10	6.8
211882	26	28	6 to 10	6.7
218672	23	24	6 to 10	6.5
219054	24	25	6 to 10	6.5
220030	27	28	6 to 10	6.5
228180	23	23	6 to 10	6.3
236632	28	27	6 to 10	6.0
236958	27	26	6 to 10	6.0
238101	24	23	6 to 10	6.0
245732	28	26	6 to 10	5.8
246434	27	25	6 to 10	5.8
248021	25	23	6 to 10	5.8
255026	19	17	6 to 10	5.6
256702	27	24	6 to 10	5.6
257942	26	23	6 to 10	5.5
266210	28	24	6 to 10	5.4
267865	27	23	6 to 10	5.3
276217	23	19	6 to 10	5.2
277785	28	23	6 to 10	5.1
288227	24	19	6 to 10	5.0
300238	25	19	6 to 10	4.8
308714	23	17	6 to 10	4.6
312246	26	19	6 to 10	4.6
322137	24	17	6 to 10	4.4
324256	27	19	6 to 10	4.4
335559	25	17	6 to 10	4.3
336267	28	19	6 to 10	4.2
348982	26	17	6 to 10	4.1
349878	23	15	6 to 10	4.1
362405	27	17	6 to 10	3.9

NOTE: See "General Planting Rate Information" and "Check Seed Population" pages for more information. Always field check seed population to verify planting rates.

VACUUM PLANTING RATES FOR MILO/SUGAR BEET/SPECIALTY 60 CELL DISCS
44 TOOTH CONTACT WHEEL DRIVE SPROCKET
APPROXIMATE SEEDS / HECTARE FOR 70 CM ROWS

70 cm Rows	Transmission Sprockets		Recomm. Speed Range (km/h)	Average Seed Spacing (cm)
	Drive	Driven		
179271	15	30*	6 to 10	8.0
192076	15	28	6 to 10	7.4
199191	15	27	6 to 10	7.2
206852	15	26	6 to 10	6.9
215126	15	25	6 to 10	6.6
217687	17	28	6 to 10	6.6
224092	15	24	6 to 10	6.4
225751	17	27	6 to 10	6.3
233835	15	23	6 to 10	6.1
234434	17	26	6 to 10	6.1
243298	19	28	6 to 10	5.9
243812	17	25	6 to 10	5.9
252309	19	27	6 to 10	5.7
253969	17	24	6 to 10	5.6
262014	19	26	6 to 10	5.5
265011	17	23	6 to 10	5.4
272494	19	25	6 to 10	5.2
283063	15	19	6 to 10	5.0
283848	19	24	6 to 10	5.0
294519	23	28	6 to 10	4.9
296190	19	23	6 to 10	4.8
305427	23	27	6 to 10	4.7
307323	24	28	6 to 10	4.6
316364	15	17	6 to 10	4.5
318707	24	27	6 to 10	4.5
320802	17	19	6 to 10	4.5
329862	23	25	6 to 10	4.3
332934	26	28	6 to 10	4.3
343605	23	24	6 to 10	4.2
344202	24	25	6 to 10	4.2
345741	27	28	6 to 10	4.1
358545	23	23	6 to 10	4.0
371825	28	27	6 to 10	3.8
372336	27	26	6 to 10	3.8
374133	24	23	6 to 10	3.8
386124	28	26	6 to 10	3.7
387227	27	25	6 to 10	3.7
389723	25	23	6 to 10	3.7
400725	19	17	6 to 10	3.6
403364	27	24	6 to 10	3.5
405312	26	23	6 to 10	3.5
418301	28	24	6 to 10	3.4
420900	27	23	6 to 10	3.4
434029	23	19	6 to 10	3.3
436490	28	23	6 to 10	3.3
452899	24	19	6 to 10	3.2
471769	25	19	6 to 10	3.0
485089	23	17	6 to 10	2.9
490641	26	19	6 to 10	2.9
506181	24	17	6 to 10	2.8
509511	27	19	6 to 10	2.8
527272	25	17	6 to 10	2.7
528381	28	19	6 to 10	2.7
548361	26	17	6 to 10	2.6
549768	23	15	6 to 10	2.6
569453	27	17	6 to 10	2.5

NOTE: See "General Planting Rate Information" and "Check Seed Population" pages for more information. Always field check seed population to verify planting rates.

**VACUUM PLANTING RATES FOR SOYBEAN 120 CELL DISC
22 TOOTH CONTACT WHEEL DRIVE SPROCKET
APPROXIMATE SEEDS / HECTARE FOR 70 CM ROWS**

70 cm Rows	Transmission Sprockets		Recomm. Speed Range (km/h)	Average Seed Spacing (cm)
	Drive	Driven		
192090	15	28	6 to 10	7.4
199205	15	27	6 to 10	7.2
206865	15	26	6 to 10	6.9
215142	15	25	6 to 10	6.6
217703	17	28	6 to 10	6.6
224105	15	24	6 to 10	6.4
225765	17	27	6 to 10	6.3
233848	15	23	6 to 10	6.1
234448	17	26	6 to 10	6.1
243314	19	28	6 to 10	5.9
243828	17	25	6 to 10	5.9
252325	19	27	6 to 10	5.7
253987	17	24	6 to 10	5.6
262030	19	26	6 to 10	5.5
265030	17	23	6 to 10	5.4
272513	19	25	6 to 10	5.2
283082	15	19	6 to 10	5.0
283867	19	24	6 to 10	5.0
294538	23	28	6 to 10	4.9
296208	19	23	6 to 10	4.8
305448	23	27	6 to 10	4.7
307345	24	28	6 to 10	4.6
316386	15	17	6 to 10	4.5
318728	24	27	6 to 10	4.5
320824	17	19	6 to 10	4.5
329884	23	25	6 to 10	4.3
332958	26	28	6 to 10	4.3
343629	23	24	6 to 10	4.2
344226	24	25	6 to 10	4.2
345762	27	28	6 to 10	4.1
358569	23	23	6 to 10	4.0
371849	28	27	6 to 10	3.8
372360	27	26	6 to 10	3.8
374160	24	23	6 to 10	3.8
386151	28	26	6 to 10	3.7
387254	27	25	6 to 10	3.7
389748	25	23	6 to 10	3.7
400755	19	17	6 to 10	3.6
403391	27	24	6 to 10	3.5
405338	26	23	6 to 10	3.5
418331	28	24	6 to 10	3.4
420929	27	23	6 to 10	3.4
434056	23	19	6 to 10	3.3
436520	28	23	6 to 10	3.3
452928	24	19	6 to 10	3.2
471801	25	19	6 to 10	3.0
485124	23	17	6 to 10	2.9
490673	26	19	6 to 10	2.9
506216	24	17	6 to 10	2.8
509546	27	19	6 to 10	2.8
527307	25	17	6 to 10	2.7
528418	28	19	6 to 10	2.7
548399	26	17	6 to 10	2.6
549806	23	15	6 to 10	2.6
569491	27	17	6 to 10	2.5

NOTE: See "General Planting Rate Information" and "Check Seed Population" pages for more information. Always field check seed population to verify planting rates.

**VACUUM PLANTING RATES FOR SOYBEAN 120 CELL DISC
28 TOOTH CONTACT WHEEL DRIVE SPROCKET
APPROXIMATE SEEDS / HECTARE FOR 70 CM ROWS**

70 cm Rows	Transmission Sprockets		Recomm. Speed Range (km/h)	Average Seed Spacing (cm)
	Drive	Driven		
244479	15	28	6 to 10	5.8
253533	15	27	6 to 10	5.6
263284	15	26	6 to 10	5.4
273818	15	25	6 to 10	5.2
277075	17	28	6 to 10	5.2
285226	15	24	6 to 10	5.0
287337	17	27	6 to 10	5.0
297626	15	23	6 to 10	4.8
298390	17	26	6 to 10	4.8
309674	19	28	6 to 10	4.6
310325	17	25	6 to 10	4.6
321141	19	27	6 to 10	4.4
323256	17	24	6 to 10	4.4
333493	19	26	6 to 10	4.3
337310	17	23	6 to 10	4.2
346833	19	25	6 to 10	4.1
360285	15	19	6 to 10	4.0
361286	19	24	6 to 10	4.0
374867	23	28	6 to 10	3.8
376995	19	23	6 to 10	3.8
388752	23	27	6 to 10	3.7
391165	24	28	6 to 10	3.7
402670	15	17	6 to 10	3.5
405653	24	27	6 to 10	3.5
408322	17	19	6 to 10	3.5
419851	23	25	6 to 10	3.4
423764	26	28	6 to 10	3.4
437346	23	24	6 to 10	3.3
438107	24	25	6 to 10	3.3
440063	27	28	6 to 10	3.2
456361	23	23	6 to 10	3.1
473262	28	27	6 to 10	3.0
473913	27	26	6 to 10	3.0
476202	24	23	6 to 10	3.0
491464	28	26	6 to 10	2.9
492868	27	25	6 to 10	2.9
496045	25	23	6 to 10	2.9
510049	19	17	6 to 10	2.8
513406	27	24	6 to 10	2.8
515886	26	23	6 to 10	2.8
532421	28	24	6 to 10	2.7
535727	27	23	6 to 10	2.7
552437	23	19	6 to 10	2.6
555570	28	23	6 to 10	2.6
576455	24	19	6 to 10	2.5
600473	25	19	6 to 10	2.4
617428	23	17	6 to 10	2.3
624494	26	19	6 to 10	2.3
644273	24	17	6 to 10	2.2
648512	27	19	6 to 10	2.2
671119	25	17	6 to 10	2.1

NOTE: See "General Planting Rate Information" and "Check Seed Population" pages for more information. Always field check seed population to verify planting rates.

**LIQUID FERTILIZER PISTON PUMP APPLICATION RATES
LITERS PER HECTARE**

**Model NGP-6055 Pumps With 18 Tooth Contact Wheel Drive Sprocket
(Planter equipped with two piston pumps.)**

Pump Setting	2	3	4	5	6	7	8	9	10
24 Row 70 cm	93.7	138.5	185.3	232.2	279.0	325.8	372.7	419.5	464.3

**Model NGP-7055 Pumps With 18 Tooth Sprocket and Ground Drive
(Planter equipped with two piston pumps.)**

Pump Setting	2	3	4	5	6	7	8	9	10
24 Row 70 cm	75.4	113.0	150.7	188.4	225.0	262.7	300.4	338.1	375.7

Charts are for planters equipped with contact drive. Check tires for correct operating pressure.

Charts calculated based on a solution weighing 1.2 kilograms per liter.

NOTE: Fertilizer application rates can vary from weights calculated in above chart. Make field checks to be sure you are applying fertilizer at desired rate.

To check the exact number of liters your fertilizer attachment will actually deliver on a 70 cm row spacing:

1. Remove hose from one fertilizer opener and insert it into a collection container secured planter frame.
2. Engage fertilizer attachment and drive forward for 53m.
3. Measure fluid mL caught in container and divide that amount by 4. Result is liters fertilizer delivered per hectare when planting in 70 cm rows (e.g. 20ml = 2 L ; 50ml= 5L; 100ml = 10L)..
4. Rinse collection container and repeat test on other rows if necessary.

DRY INSECTICIDE APPLICATION RATES
APPROXIMATE KG/HECTARE AT 8 km/h

Meter Setting	70 cm Rows
CLAY GRANULES	
10	6.0
11	6.6
12	7.4
13	8.4
14	9.4
15	10.4
16	11.7
17	13.1
18	13.9
19	16.0
20	17.3
21	18.9
22	20.0
23	21.0
24	22.9
25	25.5
26	28.1
27	29.4
28	31.0
29	33.9
30	36.1
SAND GRANULES	
5	3.5
6	6.0
7	6.5
8	7.7
9	9.5
10	10.9
11	12.4
12	13.7
13	15.4
14	17.2
15	18.9
16	21.4
17	23.7
18	26.6
19	29.6
20	31.4
21	33.7
22	36.1
23	39.0
24	42.0
25	45.0

NOTE: Chart represents average values and should be used only as a starting point. Granular chemical flows through meter opening at a nearly uniform rate regardless of roller speed. Your actual rate will vary depending on insecticide, planting speed, and plant population. Planting speed/ground speed has the greatest effect on application rate.

Field check your actual rate with insecticide you are using at speed and population you will be planting. See "Checking Granular Chemical Application Rate" in Machine Operation section for more information..

DRY HERBICIDE APPLICATION RATES
APPROXIMATE KG/HECTARE AT 8 km/h

CLAY GRANULES

Meter Setting	70 cm Rows
10	5.7
11	6.3
12	7.1
13	7.9
14	8.9
15	10.0
16	11.0
17	12.1
18	13.1
19	14.2
20	15.4
21	16.6
22	17.8
23	19.2
24	20.7
25	22.1
26	23.7
27	25.5
28	27.6
29	29.6
30	32.6

NOTE: Chart represents average values and should be used only as a starting point. Granular chemical flows through given meter opening at a nearly uniform rate regardless of roller speed. Your actual rate will vary depending on specific herbicide, planting speed, and plant population. Planting speed/ground speed has the greatest effect on application rate.

Field check your actual rate with herbicide you are using at speed and population you will be planting. See "Checking Granular Chemical Application Rate" in Machine Operation section for more information.

LUBRICATION

Following pages show locations of all lubrication points. Proper lubrication of moving parts helps ensure efficient operation of your Kinze planter and prolongs the life of friction producing parts.

Lubrication Symbols



Lubricate at frequency indicated with SAE multipurpose grease.



Lubricate at frequency indicated with high quality SAE 10 weight oil or spray lubricant.

SEALED BEARINGS

Sealed bearings are used on your Kinze planter to provide trouble free operation.

These are located on drive shafts, row units, and transmission bearings. Sealed bearings are lubricated for life and are not serviceable.

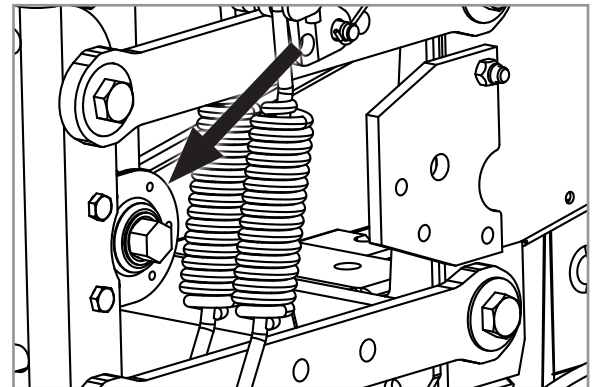

Sealed bearing (Typical)

WHEEL BEARINGS

All drive, transport, and marker hub wheel bearings should be repacked annually and checked for wear.

1. Raise wheel off ground.
2. Check for bearing endplay by moving wheel side to side.
3. Rotate wheel to check for bearing roughness. If bearings sound rough, remove hub and inspect bearings.

NOTE: To repack wheel hubs, follow procedure outlined for wheel bearing replacement in this section except bearings and bearing cups are reused.

DRIVE CHAINS

Lubricate all transmission and drive chains daily with a high quality chain lubricant. Extreme operating conditions such as dirt, temperature, or speed may require more frequent lubrication.

If a chain becomes stiff, it should be removed, soaked, and washed in solvent to loosen and remove dirt from joints. Soak chain in oil so lubricant can penetrate between rollers and bushings.

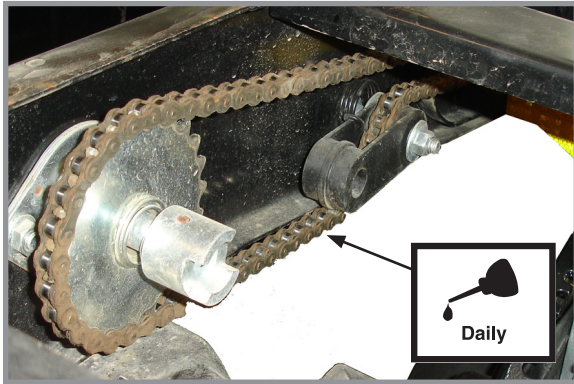

Row unit granular chemical drive chains

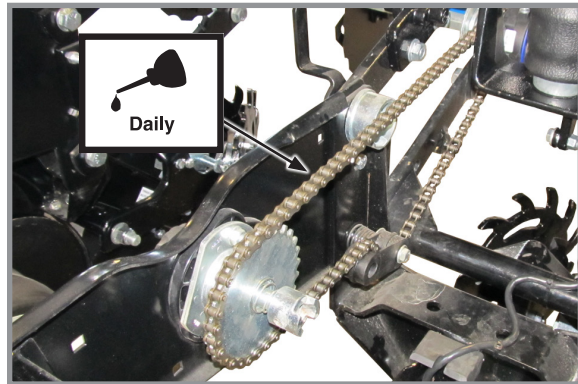

Row unit drive chains

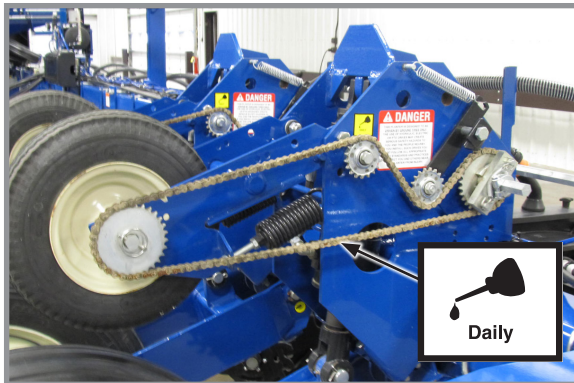

Contact wheel drive chains

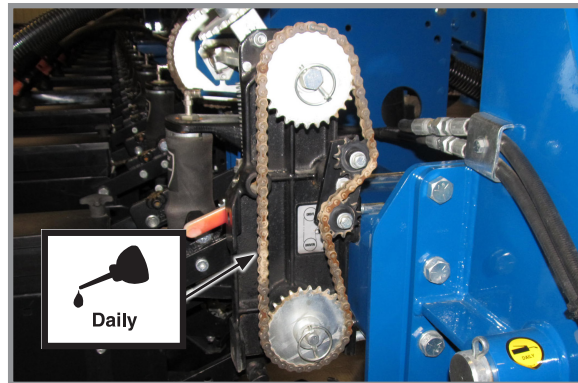

Transmission chains

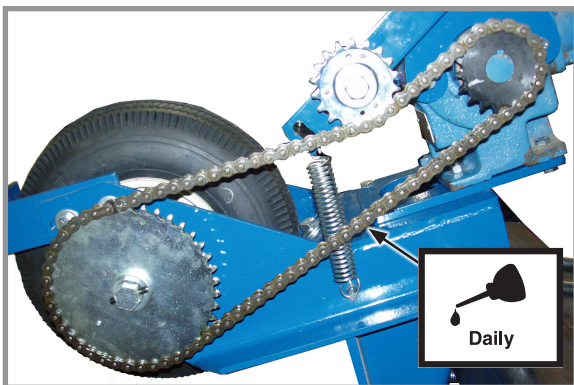

Optional piston pump drive chain

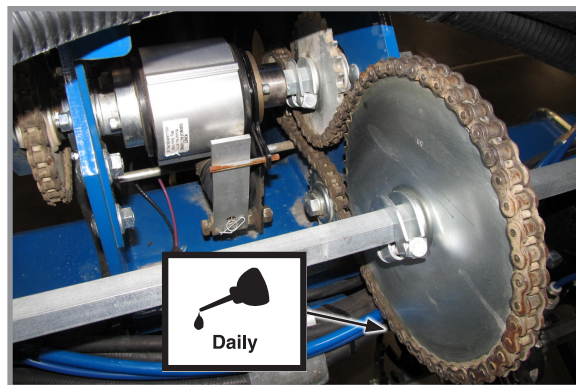

Inner module (point row clutch) drive chains

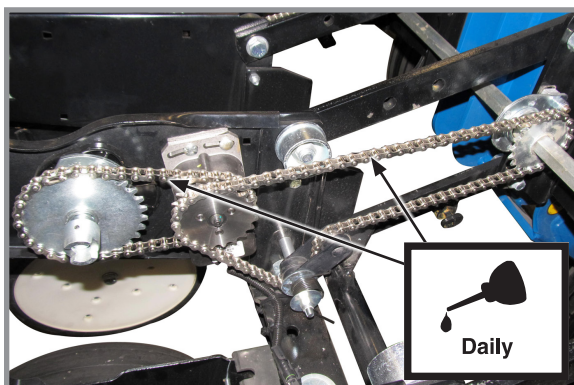

Row Unit Electric Clutches

BUSHINGS

Lubricate bushings at frequency indicated.

Check each bolt for proper torque. If bolt is loose, removed it and inspect bushing for cracks and wear. Replace bushing if necessary. Use **only hardened flat washers**. **Replace damaged flat washers with proper part. Torque hardware to 176 Nm.**

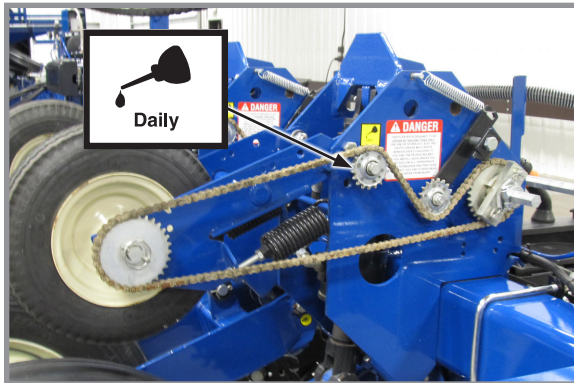

Contact wheel arm (2 per assembly)

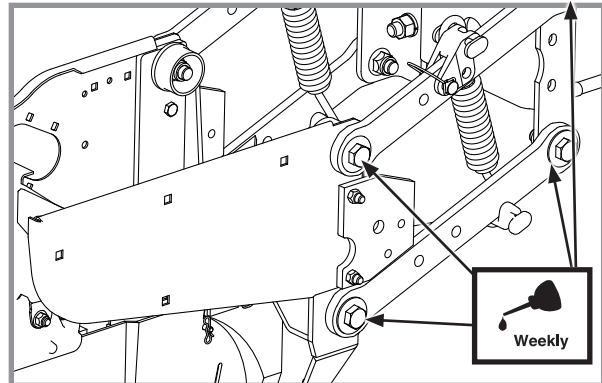

Pull Row Unit And/Or Push Row Unit Parallel Linkages (8 Per Row)

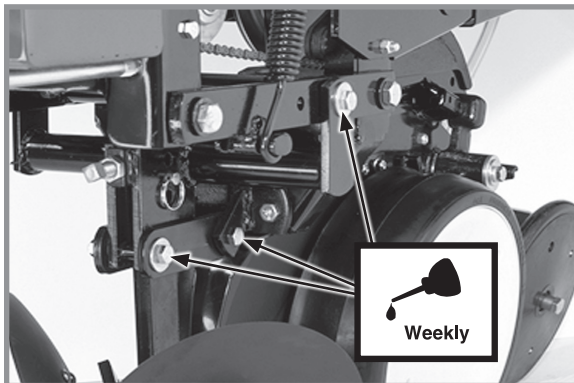

Row unit mounted disc furrower parallel linkages (6 per row)

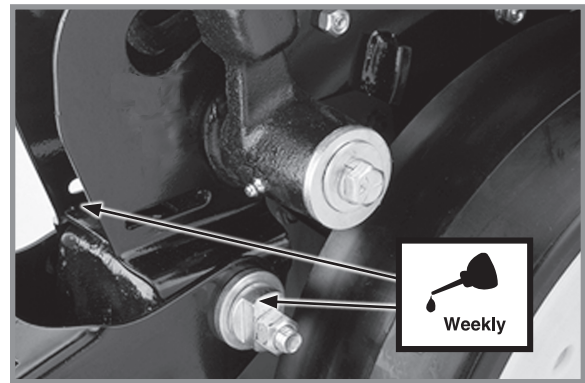

Row unit "v" closing wheel, covering discs/ single press wheel and/or drag closing wheel eccentric bushings (2 per row)

SLIDING HITCH LINKAGE

Inspect linkage daily to ensure free movement of axle links in slides.

Keep axle link slides clean. **DO NOT GREASE** the axle link slides. Powdered graphite may be used if lubrication is desired.

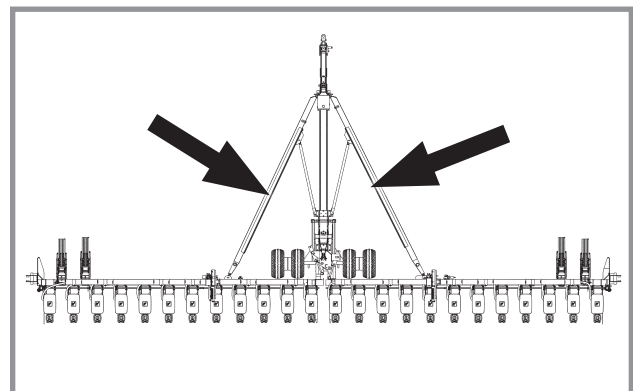

PTO SHAFT COUPLING

Clean and grease PTO shaft coupling each time pump is installed.

Apply coating of high-speed industrial coupling grease, such as Chevron® Coupling Grease meeting AGMA CG-1 and CG-2 Standards to extend shaft spline life.

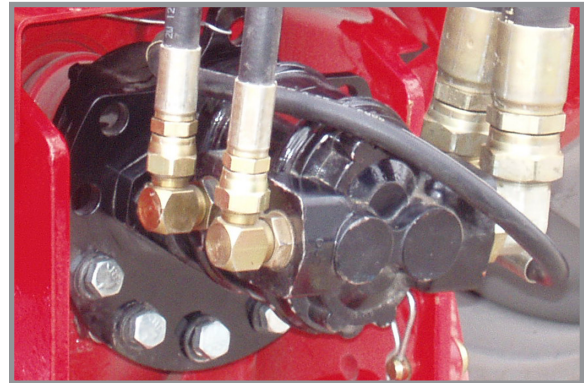

PTO pump installed

WRAP SPRING WRENCH ASSEMBLY

Wrap spring wrench components may require occasional lubrication to operate correctly using a high quality spray lubricant.

Operate wrap spring wrench when lubricating so lubricant can be absorbed into wrap spring area.

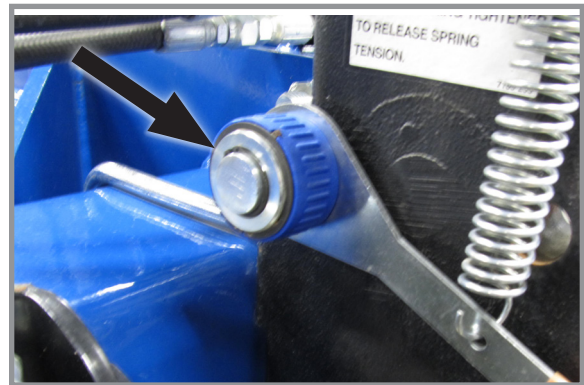

Wrap spring wrench lubrication

LIQUID FERTILIZER PISTON PUMP CRANKCASE OIL LEVEL

Check crankcase oil daily and maintain at oil level check plug. Fill as needed with EP 90 weight gear oil. Total oil capacity is approximately $\frac{3}{4}$ pint.

Refer to operator and instruction manual supplied with pump and flow divider for more information.

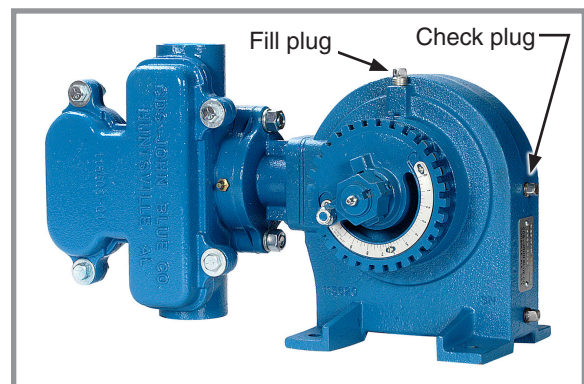

Piston pump oil fill and check plug locations

GREASE FITTINGS



WARNING

Uncontrolled machine movement can crush or cause loss of control resulting in death, serious injury, or damage to property and equipment. Install all safety lockup devices before working under or transporting this equipment.

Parts equipped with grease fittings should be lubricated at frequency indicated with an SAE multipurpose grease. Clean fitting thoroughly before using grease gun. Frequency of lubrication recommended is based on normal operating conditions. Severe or unusual conditions may require more frequent attention.

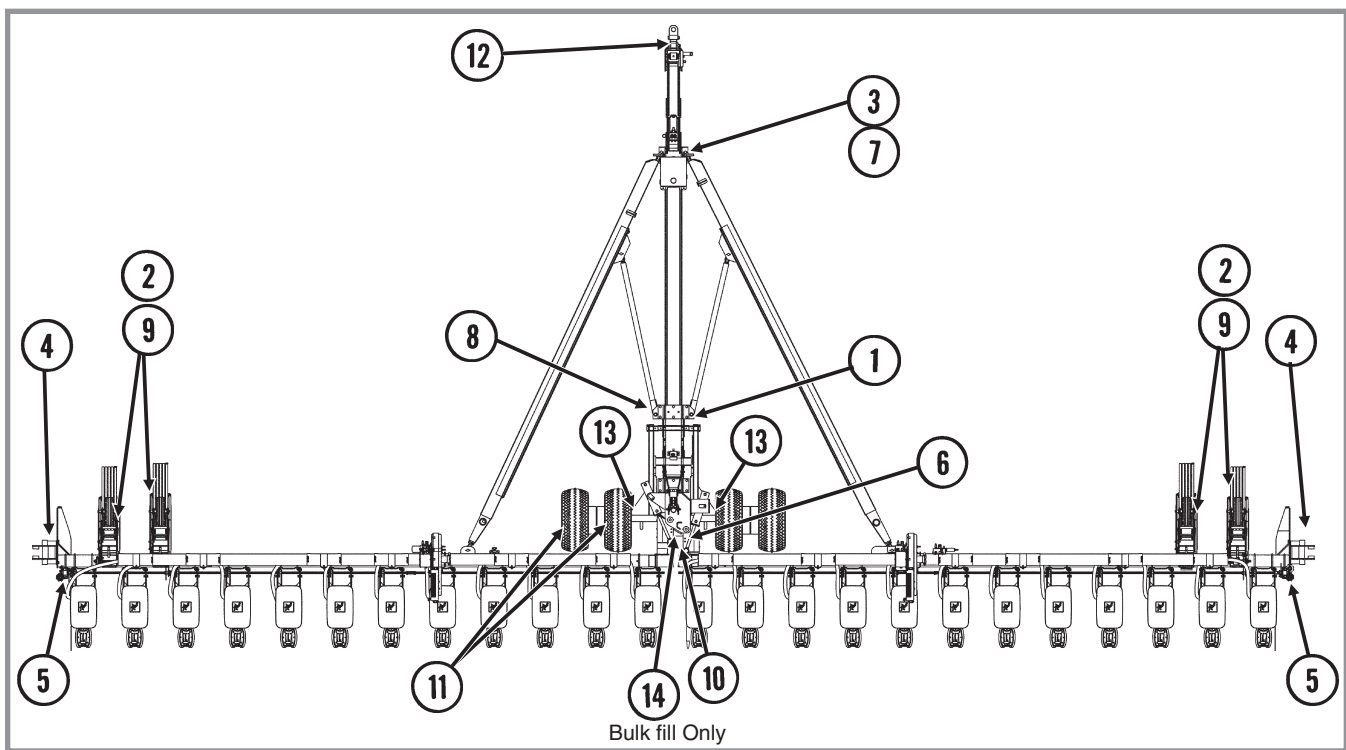

NOTE: Numbers on illustration above correspond to photos on following pages showing lubrication frequencies.

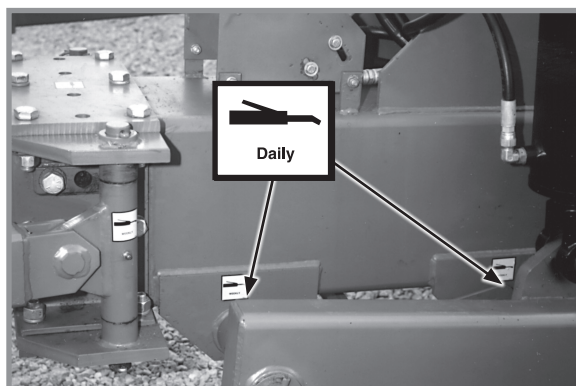

1. Axle and automatic safety lock pivots (7)

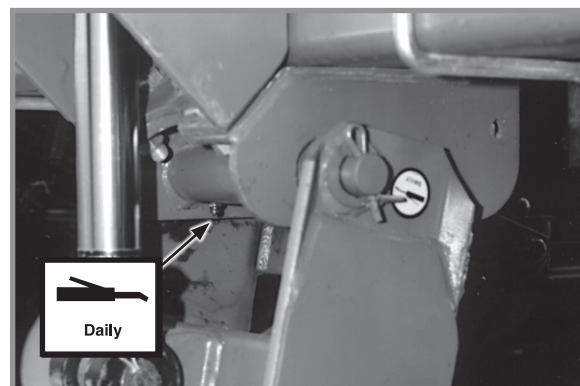

2. Ground drive wheel pivot (2 per wheel module)

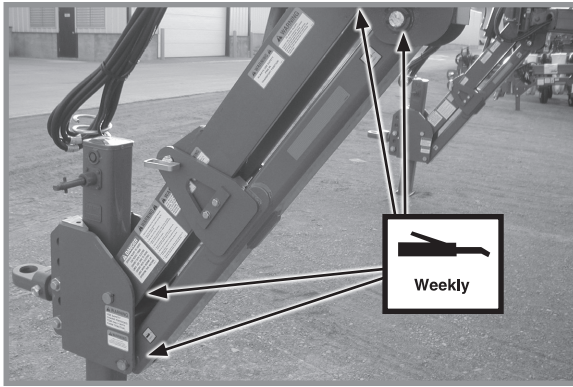

3. Upper and lower hitch linkage (2 per link)

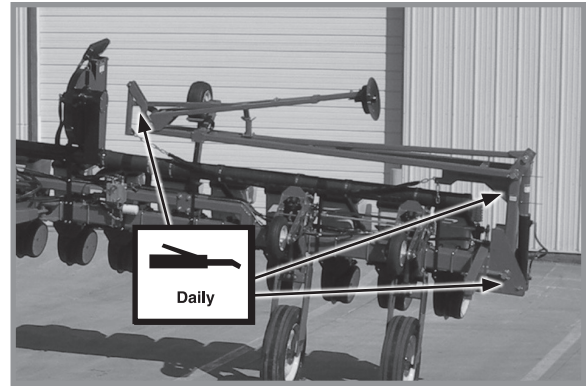

4. Row Marker Assemblies (11 per side)
(General locations shown)

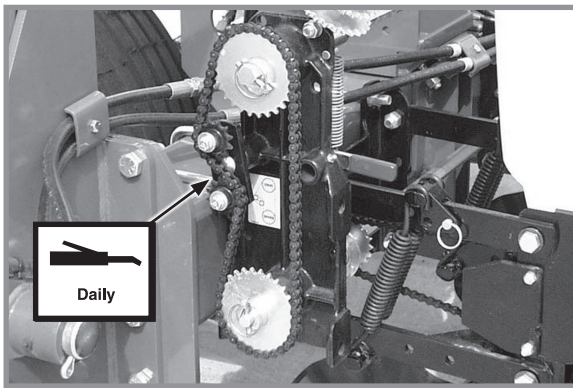

5. Seed rate transmission assembly idler pivot
(1 per assembly)

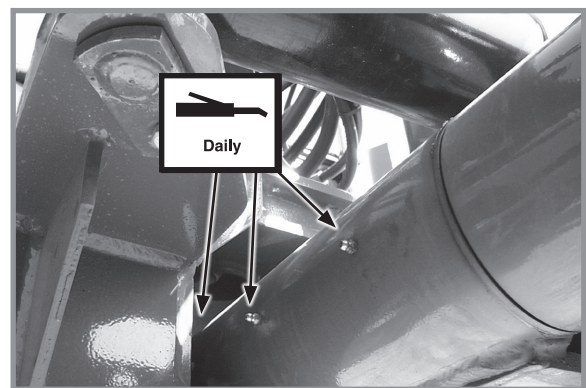

6. Wing pivot knuckle
(3 per knuckle on horizontal shaft)

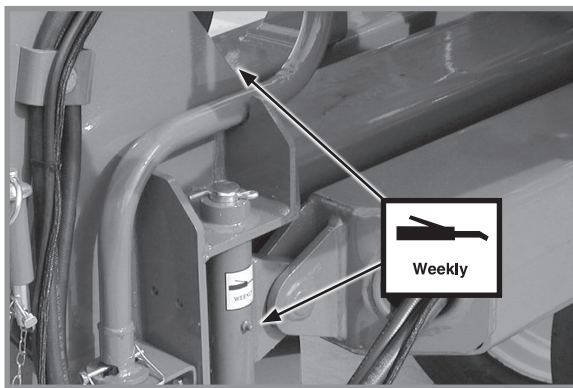

7. Link assemblies (1 per assembly)
Front wear pads (4)

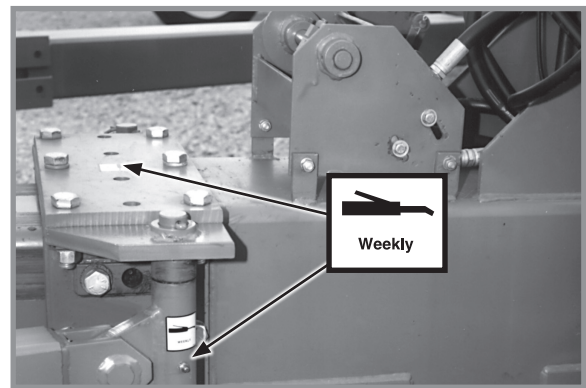

8. Axle link assemblies (1 per assembly)
Rear wear pads (2 sets - 16)

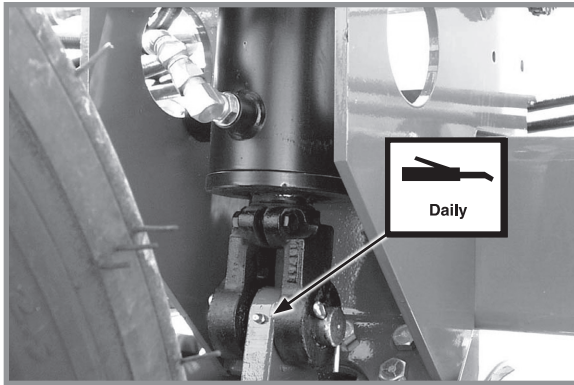

9. Wheel module lift cylinder mount (1 per wheel module)

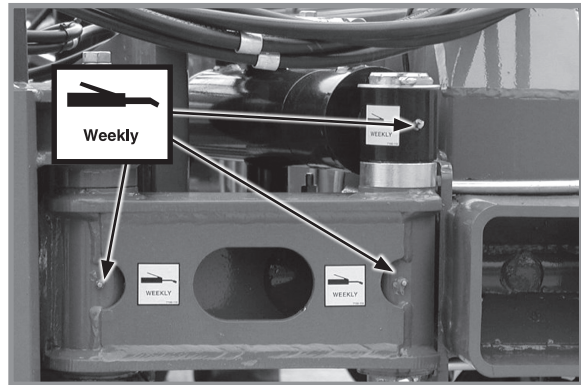

10. Wing pivot knuckle - 1 per knuckle on shaft
Helper cylinders (1 per cylinder)



11. Transport wheel bearing (1 per wheel hub)

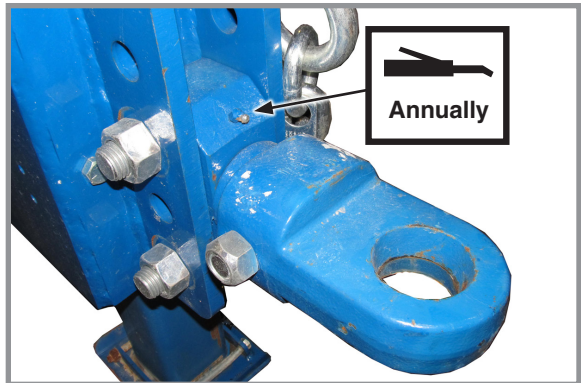

12. Swivel block (1)

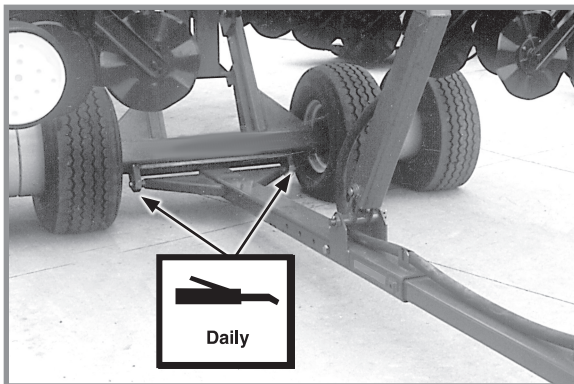

13. Rear trailer hitch pivot (2)

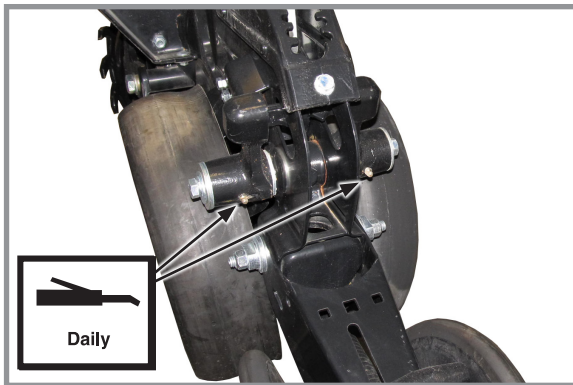

Gauge wheel arms (2)

Seals in gauge wheel arm are installed with lip facing out to allow grease to purge dirt away from seal. Pump grease into arm until fresh grease appears between washers and arm.

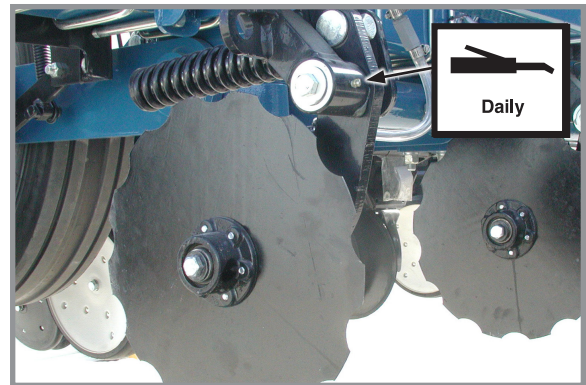

Notched single disc opener (1 per arm)

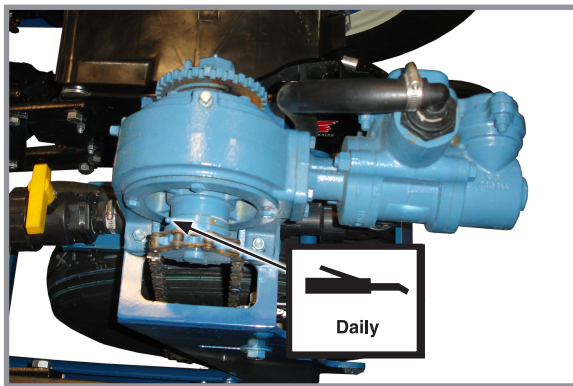

Piston pump L.H. side (1)

Fill until grease seeps out of bottom drain hole.

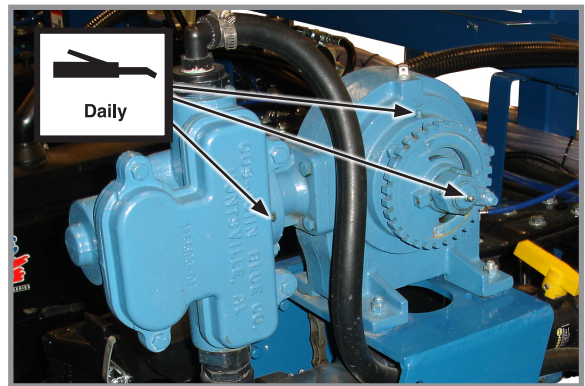

Piston pump R.H. side (3)

MOUNTING BOLTS AND HARDWARE

Before operating planter for the first time, check all hardware is tight. Check all hardware again after first 50 hours of operation and beginning of each planting season.

All hardware used on the Kinze planter is Grade 5 (high strength) unless otherwise noted. Grade 5 cap screws are marked with three radial lines on the head. Hardware must be replaced with equal size, strength, and thread type.

WARNING

Loose transport wheel lug nuts can result in wheel separation from planter and can result in death, serious injury, and damage to property and equipment. Check transport wheel lug nut torque before operating planter for the first time and periodically thereafter.

NOTICE

Over-tightening hardware can reduce its shock load capacity and cause equipment failure.

TORQUE VALUES CHART - PLATED HARDWARE

Diameter	Grade 2 (No marks)		Grade 5 (3 marks)		Grade 8 (6 marks)	
	Coarse	Fine	Coarse	Fine	Coarse	Fine
1/4"	5.6 Nm	6.3 Nm	8.6 Nm	9.8 Nm	12 Nm	14 Nm
5/16"	11 Nm	12 Nm	18 Nm	19 Nm	24 Nm	27 Nm
3/8"	20 Nm	23 Nm	31 Nm	35 Nm	45 Nm	50 Nm
7/16"	34 Nm	37 Nm	50 Nm	56 Nm	71 Nm	79 Nm
1/2"	48 Nm	54 Nm	77 Nm	87 Nm	108 Nm	122 Nm
9/16"	68 Nm	81 Nm	108 Nm	122 Nm	156 Nm	176 Nm
5/8"	95 Nm	108 Nm	149 Nm	169 Nm	217 Nm	244 Nm
3/4"	176 Nm	197 Nm	271 Nm	298 Nm	380 Nm	427 Nm
7/8"	169 Nm	190 Nm	434 Nm	475 Nm	610 Nm	678 Nm
1"	258 Nm	278 Nm	651 Nm	719 Nm	915 Nm	1017 Nm
1 1/8"	359 Nm	407 Nm	814 Nm	908 Nm	1302 Nm	1458 Nm
1 1/4"	508 Nm	563 Nm	1139 Nm	1261 Nm	1844 Nm	2034 Nm
1 3/8"	664 Nm	759 Nm	1491 Nm	1695 Nm	2413 Nm	2752 Nm
1 1/2"	881 Nm	990 Nm	1966 Nm	2237 Nm	3128 Nm	3620 Nm

TORQUE VALUES - PNEUMATIC DOWN PRESSURE

Diameter	Torque Value
1/8" NPT	120 in-lb (14 Nm) Maximum
1/2"-13	180 in-lb (20 Nm) Maximum
3/4"-16	180 in-lb (20 Nm) Maximum

NOTE: Use these torque values with pneumatic down pressure components.

SPECIAL TORQUE VALUES & INSTRUCTIONS

Row unit parallel linkage bushing hardware	130 ft-lb (176 Nm)
5/8" No till coulter spindle hardware	120 ft-lb (162 Nm)
Transport Tire Inner Budd Nuts**	315 ft-lb (427 Nm)
Transport Tire Outer Budd Nuts**	1075 ft-lb (1458 Nm)

****NOTE: Loosen outer budd nut first, then loosen inner budd nut.**

CYLINDER ROD PISTON RETAINING NUT TORQUE CHART

	Non-Nylock Nut	Nylock Nut
½"-20	55-70 ft-lb (75-95 Nm)	45-55 ft-lb (61-75 Nm)
¾"-16	115-125 ft-lb (156-169 Nm)	100-115 ft-lb (136-156 Nm)
7/8"-14	150-180 ft-lb (203-244 Nm)	130-150 ft-lb (176-203 Nm)
1"-14	275-330 ft-lb (373-447 Nm)	250-275 ft-lb (339-373 Nm)
1 1/8"-12	300-375 ft-lb (407-508 Nm)	275-300 ft-lb (373-407 Nm)
1 1/4"-12	300-375 ft-lb (407-508 Nm)	275-300 ft-lb (373-407 Nm)

TORQUE VALUES - WHEEL LUG NUTS

Wheel Nut Size	Torque Value	Interval
5/8" - 18 Wheel Lug Nuts and Lug Bolts	200 ft-lb (270 Nm)	<ul style="list-style-type: none"> Once before first planting; Again after first 50 km or 10 operational hours; Periodically thereafter (at least once before every planting season).
9/16" - 18 Wheel Lug Nuts and Lug Bolts	125 ft-lb (170 Nm)	<ul style="list-style-type: none"> Once before first planting; Again after first 50 km or 10 operational hours; Periodically thereafter (at least once before every planting season).

TIRE PRESSURE



WARNING

Explosive separation of rim and tire parts can cause death or serious injury. Overinflation, rim and tire servicing, improper use of rims and tires, or worn or improperly maintained tires could result in a tire explosion.



- Maintain proper tire pressure. Inflating a tire above or below the recommended pressure can cause tire damage.
- Mount tires only by properly trained personnel using proper equipment.
- Replace tires with cuts or bubbles. Replace damaged rims. Replace missing lug bolts and nuts.
- Do not weld or heat wheel assembly. Heating increases tire pressure.

TRANSPORT TIRES

WARNING

Over-inflation of tires can result in explosive separation of rim and tire and cause death or serious injury. Different size rims are designed for different tire pressures. Inflate to correct pressure for specific rim size.

Do not exceed following maximum pressures:

- Rims stamped with “224”: 75 PSI (517 kPa) maximum pressure.
- Rims stamped with “276”: 100 PSI (689 kPa) maximum pressure.

INFLATION SPECIFICATIONS

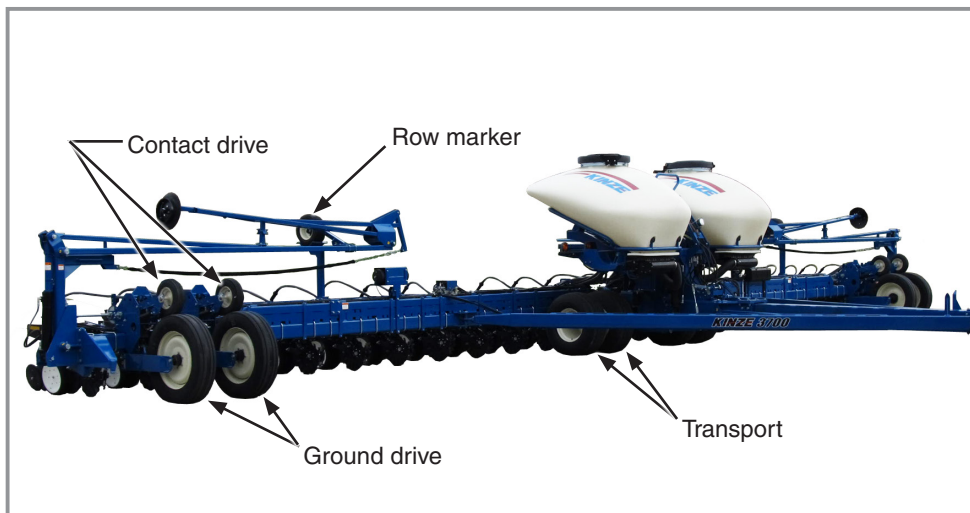

Tire locations (L.H. mirrors R.H. shown)

Ground drive (wings) 255-70R 22.5	75 PSI (517 kPa)
Transport - 36" x 16" x 17.5"	75 PSI (517 kPa)
Contact drive - 4.80" x 8"	50 PSI (345 kPa)
Row marker - 16" x 6.5" x 8"	14 PSI (97 kPa)
Liquid fertilizer piston pump (Not shown) 4.10" x 6"	50 PSI (345 kPa)

VACUUM SEED METER MAINTENANCE

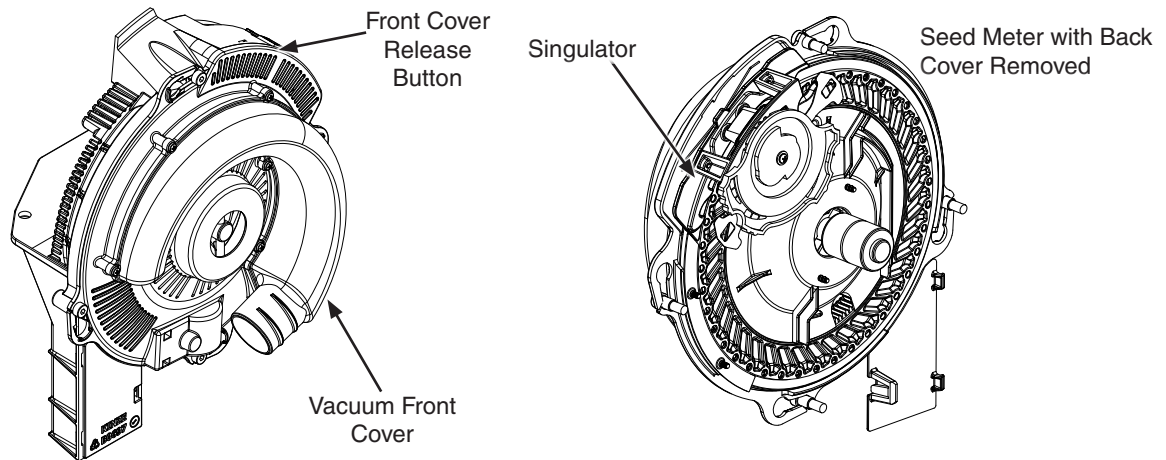

Before each planting season inspect seed discs and singulator and clean or replace as needed.

Use clean, high quality seed for maximum meter accuracy. Damaged or cracked seed, hulls, and foreign material may become lodged in seed disc orifices and greatly reduce meter accuracy.

Inspect and clean seed discs daily checking for any buildup of foreign material and blocked orifices. If seed disc orifices are plugged frequently with seed remnants, remnants ejector wheel may need to be replaced. Clean seed disc by washing it with soap and water. Dry thoroughly.

Inspect singulator blades and guide for wear after every 80 hectares per row of operation. If adjustment of singulator blade does not affect meter performance or if blades appear worn, singulator blade may need to be replaced.

Replace seed disc or vacuum seal if abnormally high vacuum is required or if consistent operation cannot be achieved.

See [“Preparation for Storage” on page 5-32](#) for additional Vacuum Seed Metering System maintenance.

NOTE: Remove seed discs from meters for annual storage and store them vertically on a dowel or pipe.

SEED METER CLEANOUT

NOTE: Use of damaged seed or seed containing foreign material will cause plugging of seed cell orifices and require more frequent seed meter cleanout to prevent underplanting.

Thorough seed meter cleanout is important to maintain genetic purity.

1. Disengage seed drive and remove seed hopper and meter.
2. Dump seed from right rear corner of hopper into a container.
3. Lay hopper on its right side. Push release button and rotate seed meter vacuum cover clockwise to align keyhole slots with bolt heads. Lift off cover.
4. Rotate seed disc hub clockwise to unlock and remove seed disc.
5. Empty meter.
6. Thoroughly inspect meter to ensure all seed is removed.
7. Replace seed disc. Install vacuum cover.

GAUGE WHEEL ADJUSTMENT

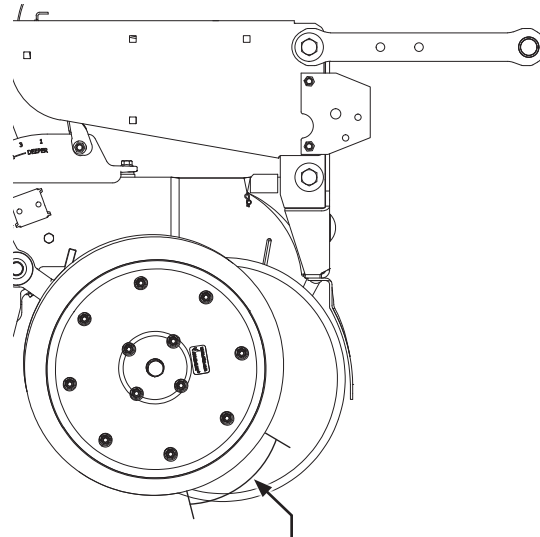
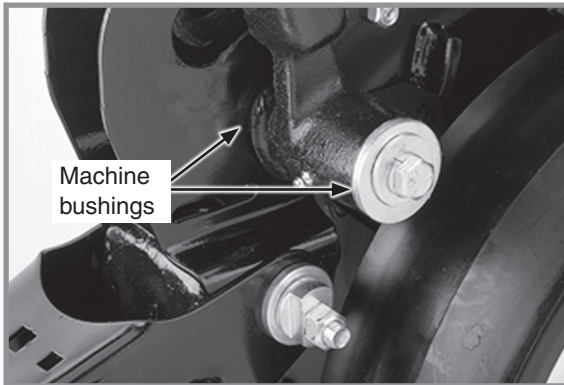

NOTE: It may be desirable to space gauge wheel further from blade when operating in sticky soils.

NOTE: Set depth adjustment handle at 3x2 position and lift gauge wheel to stop one side at a time.

Shim gauge wheel to lightly contact opener disc blade in this area for 4" to 6" (10-15 cm). Check adjustment in operating position.

Gauge wheels should lightly contact opener blades to prevent accumulation of dirt or trash. Gauge wheels and opener blades should turn with only slight resistance.

Add or remove machine bushings between shank and gauge wheel arm to adjust clearance between gauge wheels and opener blades. Store remaining machine bushings between gauge wheel arm and flat washer on outer side of gauge wheel arm.

Contact should be no less than one half of the rotation of the wheel, while not sticking in any position (it does not have to be continuous) Wheel should rotate in the direction of travel of the row unit. Wheel can be held in position by supporting the spindle bolt head.

GAUGE WHEEL ARM PIVOT SPINDLE REPLACEMENT

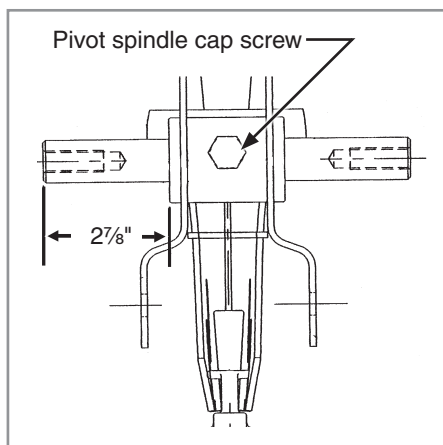

Gauge Wheel Pivot Spindle

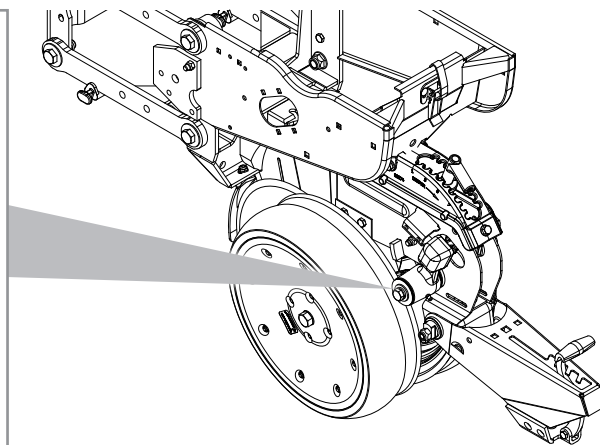

1. Remove gauge wheel and arm assemblies from shank assembly.

2. Remove 1/2" x 3/4" cap screw that locks pivot spindle in place and remove spindle.
3. Install replacement spindle and position as shown. Exact centering is critical.
4. Install 1/2" x 3/4" cap screw and torque to lock pivot spindle in place.
5. Install gauge wheel and arm assemblies. Shim for proper gauge wheel tire/disc blade clearance.

GAUGE WHEEL ARM BUSHING/SEAL REPLACEMENT

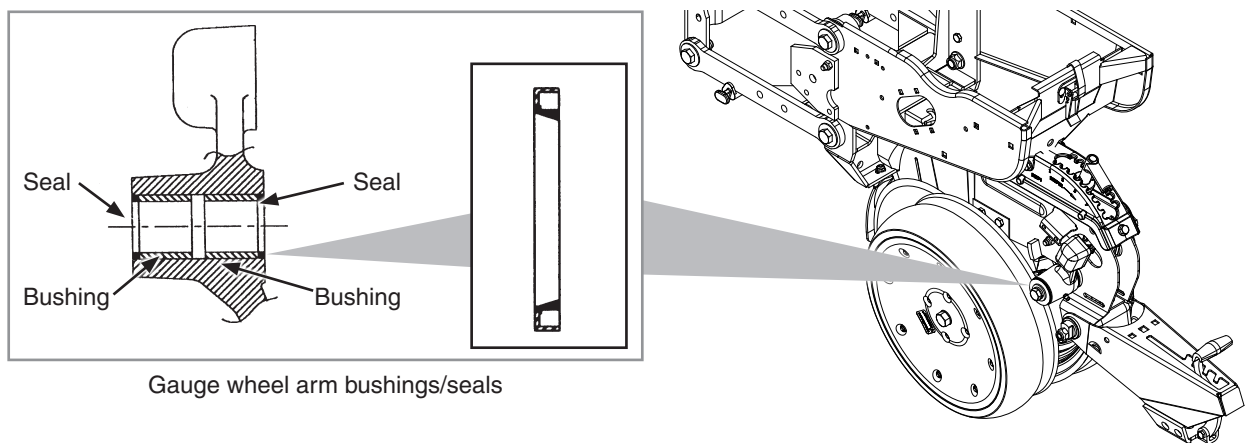

NOTE: Gauge Wheel Arm Bushing and Seal Driver Kit (G1K296) is available through your Kinze Dealer.

1. Remove gauge wheel from arm.
2. Remove gauge wheel arm from shank assembly.
3. Remove seal and bushing and discard. Clean and dry inner bore.
4. Drive/press replacement bushing inside bore of arm to a depth of .125" below flush.
5. Coat wiping edge of seal with grease.
6. Drive/press seal into place with lip to outside.

NOTE: Use extra care to protect the sealing lip during installation. Apply uniform pressure to assemble the seal into the bore of the arm. Never apply a direct hammer blow to the seal surface.

7. Inspect gauge wheel pivot spindle.
8. Reinstall gauge wheel arm assembly and gauge wheel.

NOTE: Use special machine bushing between gauge wheel arm and gauge wheel.

9. Shim for proper gauge wheel tire/disc blade clearance.
10. Lubricate with an SAE multipurpose grease.

15" SEED OPENER DISC BLADE/BEARING ASSEMBLY

NOTICE

Excessive blade contact may result in premature disc opener bearing/hub failures and excessive wear on seed tube guard/inner scraper. When properly adjusted, if one blade is held in fixed position, opposite blade should rotate with less than 5 pounds force (~22 N) at outer edge of blade.

Maintain approximately $1" \pm \frac{1}{2}"$ (~2.5 ± 1 cm) of blade-to-blade contact to properly open and form seed trench. As blade diameter decreases due to wear, it is necessary to relocate machine bushings from inside to outside to maintain $1" \pm \frac{1}{2}"$ (~2,5 ± 1 cm) of contact.

NOTE: Proper blade clearance is critical. Blades should have $1" \pm \frac{1}{2}"$ (~2,5 ± 1 cm) contact in this area. When blades are turned by hand in opposite directions against each other, there should be only light resistance to turning. Re-adjust blade scraper if necessary to center it between the blades.

NOTE: Replace blades if proper blade-to-blade contact cannot be maintained after relocating machine bushings or if blade diameter wears below $14\frac{1}{2}"$ (~37 cm).

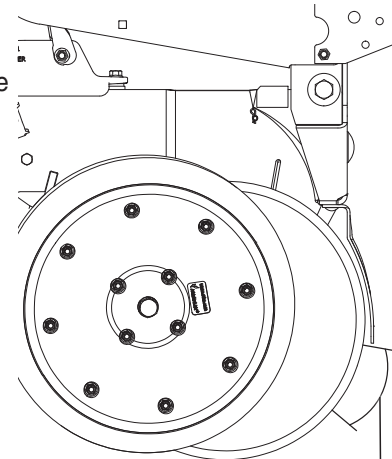

Approximately $1" \pm \frac{1}{2}"$
(3 ± .5 cm) of
blade-to-blade contact.

REPLACE DISC BLADE/BEARING ASSEMBLY

NOTE: Only bearing may need to be replaced if there is excessive endplay or if bearing sounds or feels rough when disc blade is rotated.

1. Remove gauge wheel, scraper, and bearing dust cap.
2. Remove cap screw, washer and disc blade/bearing assembly. Machine bushings between shank and disc blade are used to maintain approximate 25 mm \pm 13 mm of blade-to-blade contact.

NOTICE

Left hand side of opener uses a left hand threaded cap screw. DO NOT OVER TIGHTEN. Damage to shank threads require replacement of row unit shank assembly.

3. Install machine bushing(s), new disc blade bearing assembly, washer and cap screw. Torque $\frac{5}{8}$ "-11 Grade 5 cap screw to 150 Nm.

NOTE: Replace disc blades only with disc blades of equal thickness.

4. Install bearing dust cap, scraper, and gauge wheel.

REPLACE BEARING ONLY

1. Remove gauge wheel, scraper, bearing cap, cap screw, washer and disc blade/bearing assembly.
2. Remove $\frac{1}{4}$ " rivets from bearing housing to expose bearing.
3. Installing new bearing. install three evenly spaced $\frac{1}{4}$ " cap screws into three of six holes in bearing housing to hold bearing and bearing housing in place. Install rivets in other three holes. Remove $\frac{1}{4}$ " cap screws and install rivets in those three holes.
4. Reinstall disc blade/bearing assembly, washer and cap screw. Torque $\frac{5}{8}$ "-11 cap screw to 150 Nm.
5. Install bearing dust cap, scraper, and gauge wheel.

SEED TUBE GUARD/INNER SCRAPER

Seed tube guard protects seed tube and acts as inner scraper for seed opener disc blades.

Remove seed tube and check for wear. Excessive wear on seed tube indicates a worn seed tube guard. Replace seed tube guard if it measures 16 mm or less at lower end. A new seed tube guard measures approximately 22 mm.

NOTE: No till planting or planting in hard ground conditions, especially when planter is not equipped with no till coulters, and/or excessive blade-to-blade contact increases seed tube guard wear and requires more frequent inspection and/or replacement.

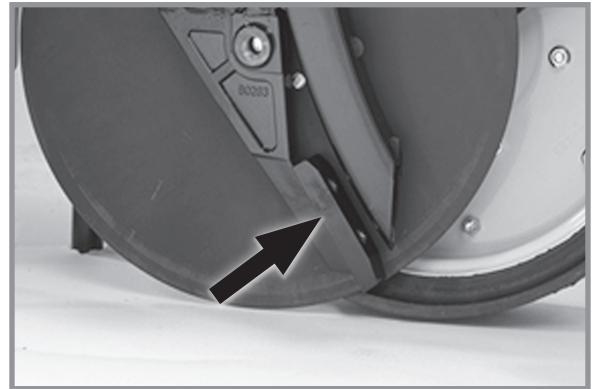

Seed tube guard/inner scraper
(Gauge wheel/seed opener disc blade removed)

NOTICE

Over tightening hex socket head cap screws may damage shank threads and require replacement of shank. An excessively worn seed tube guard may allow blades to wear into row unit shank, also requiring replacement of shank.

Remove seed tube and two hex socket head cap screws that attach seed tube guard. Hold replacement seed tube guard centered between seed opener disc blades. Install hex socket head cap screws. **DO NOT TIGHTEN.** Using a clamp or vise-grip, squeeze opener blades together in front of seed tube guard. Tighten seed tube guard retaining screws. Remove clamps. Distance between seed tube guard and opener blades should be equal on both sides. Reinstall seed tube.

ROW UNIT MOUNTED DISC FURROWER

Lubricate bushings in support arm mounting bracket at frequency indicated in Lubrication of this section. Check each bolt for proper torque. If bolt is loose, it should be removed and bushing inspected for cracks and wear. Replace bushings as necessary.

NOTE: Use only hardened flat washers. Replace damaged flat washers with proper part. Torque bolts to 176 Nm.

Blade hubs are equipped with sealed bearings. Replace bearings if a bearing sounds or feels rough when wheel is rotated.

Replace solid or notched 12" (30.5 cm) diameter blades when worn to 28 cm.

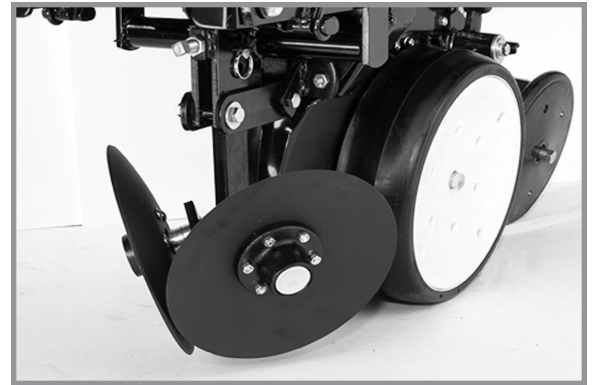

Row unit mounted disc furrower

GRANULAR CHEMICAL ATTACHMENT

Before storing planter, disengage granular chemical drive by rotating throwout knob $\frac{1}{4}$ turn counterclockwise. Remove drive chain and empty and clean all granular chemical hoppers. Clean drive chains and coat them with a rust preventive spray or submerge chains in oil. Inspect and replace worn or broken parts.

Install hoppers and chains. Check chain alignment.

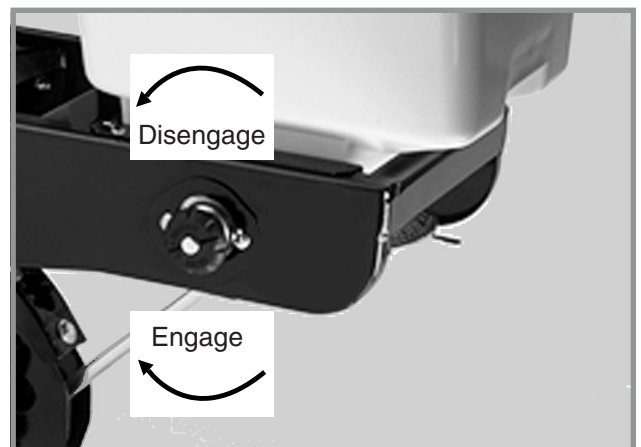

SPIKED CLOSING WHEEL

Inner parts of spiked closing wheel will begin to wear at approximately 70% of life. Flip/reverse wheel to utilize remaining life of wheel.

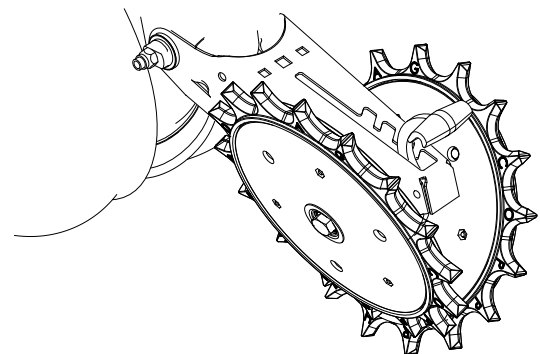

Row Unit Spiked Closing Wheel

ROW UNIT MOUNTED NO TILL COULTER

Check nuts and hardware periodically for proper torque. Be sure coulters are positioned square with row unit and aligned in front of row unit disc opener.

NOTE: Torque $\frac{5}{8}$ " spindle hardware to 162 Nm.

Coulter blade can be adjusted to one of four settings. Initially blade is set in highest position. As blade wears it can be adjusted to one of three lower settings. See "Row Unit Mounted No Till Coulter" in Row Unit Operation section of this manual.

Replace 16" (40.6 cm) diameter coulters when worn to 37 cm.



Row unit mounted no till coulters

COULTER OR ROW UNIT MOUNTED RESIDUE WHEELS



Coulter mounted residue wheels

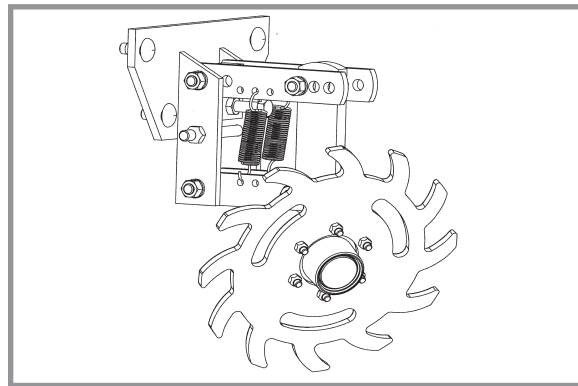

Row unit mounted residue wheels

Wheel hubs are equipped with sealed bearings. If a bearing sounds or feels rough when wheel is rotated, replace them.

POINT ROW CLUTCH MAINTENANCE

Point row clutch is permanently lubricated and sealed and requires no periodic maintenance.

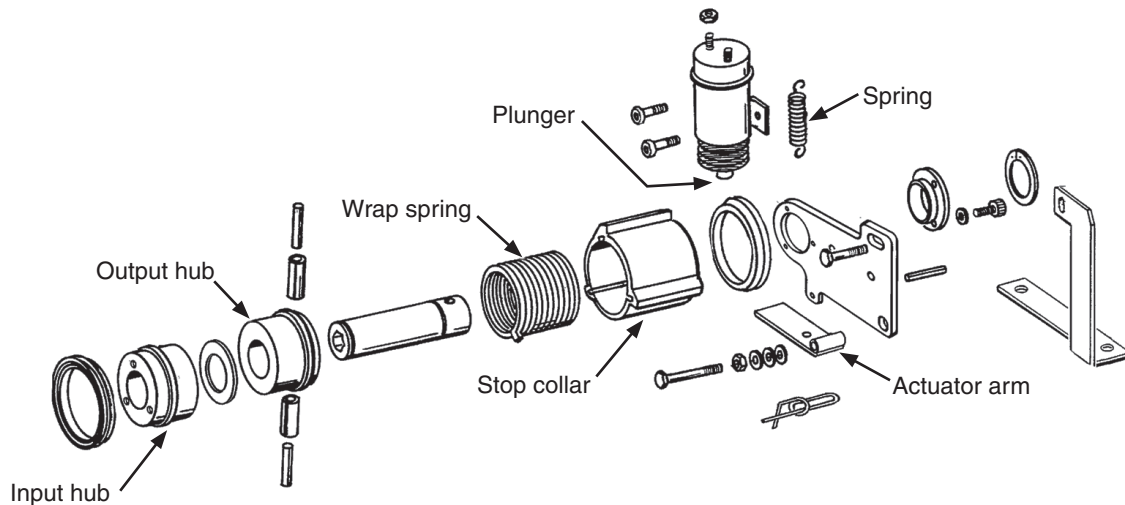

Single point row clutch main parts

WRAP SPRING WRENCH CLEANING AND REPAIR

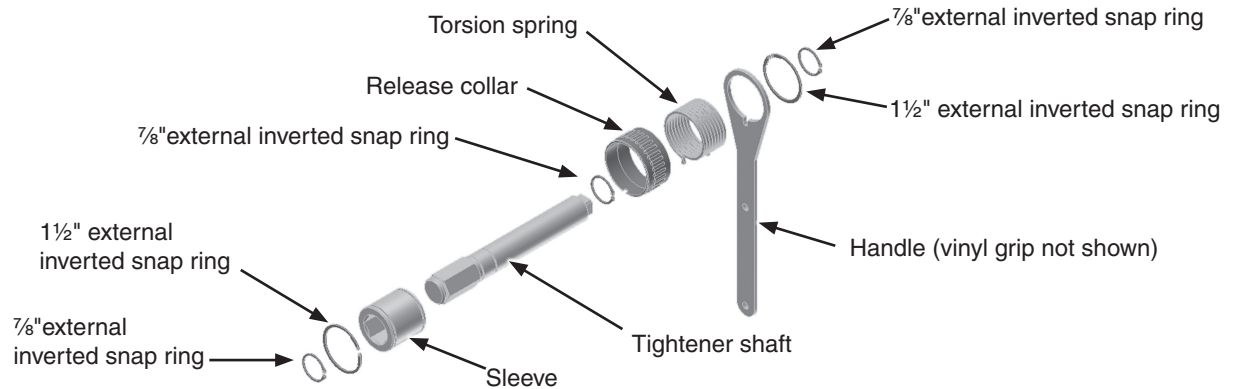

1. Remove $\frac{1}{4}$ "-20 x $\frac{1}{2}$ " cap screw securing idler with sprockets to wrench tightener shaft and remove wrap spring wrench from planter.
2. Remove split rings and disassemble as shown above. Soak metal parts in solvent and thoroughly clean.

NOTE: L.H. and R.H. release collars and torsion springs are different. Order correct parts for each assembly.

3. Replace damaged parts. Lubricate parts with high quality silicon lubricant and reassemble.
4. Reinstall wrap spring wrench on planter.

TESTING AND FUSE REPLACEMENT

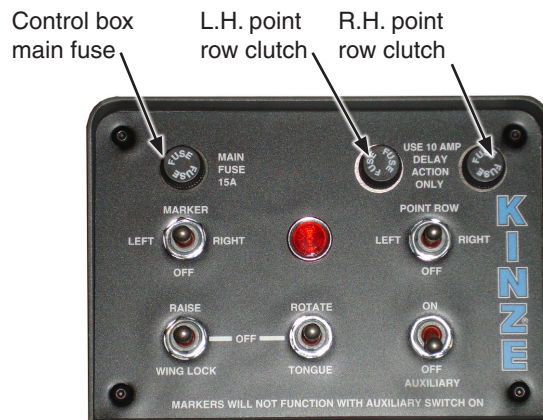

Single speed point row clutch control box (Front View)

NOTE: Replace all point row fuses with MDL 10 amp slow blow fuses.

If the clutch or clutches fail to operate, first determine if problem is electrical or mechanical.

Place operation switch in RIGHT or LEFT position. Solenoid plunger will retract causing a clicking sound if it is operating properly. Touch plunger with a metal object to check if it is electrically magnetized. Check clutch and wiring harness for power with a test light or volt meter.

NOTE: R.H. clutch operates clockwise and L.H. clutch operates counterclockwise. Clutch parts such as the wrap spring are side specific. Use correct repair part if a clutch must be repaired.

Also see “Point Row Clutch Troubleshooting” in Troubleshooting section.

ACTUATOR ARM ADJUSTMENT

Gap between actuator arm and stop on stop collar should be 3.2 mm (± .8 mm) when solenoid is NOT engaged.

Loosen nut on mounting pin and move pin in slot until there is a 3.2 mm (± .8 mm) gap between arm and stop on stop collar. Retighten nut.

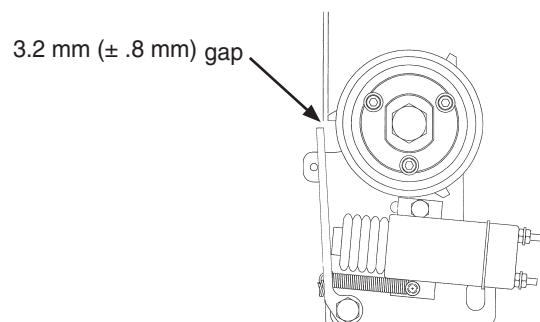

PLANTER MOUNTED PUMP DRIVE AND OIL COOLER

NOTICE

Clean and grease PTO shaft coupling with high-pressure industrial coupling grease (Chevron® coupling grease or equivalent) meeting AGMA CG-1 and CG-2 Standards each time driveshaft is installed or premature wear and equipment failure can occur.

NOTE: Periodically check and clean oil coolers.

1. Replace 10-micron spin-on filters on each wing annually.
2. Fill system with SAE 10W-20 multigrade wide temperature range transmission hydraulic fluid. Reservoir capacity is approximately 38L.
3. Start system and run with tractor at idle and fans turned off for 1-2 minutes. Switch fans to full speed and run with tractor at idle for 1-2 minutes.
4. Check reservoir fluid level and fill as required. Hydraulic fluid level should be within 2.5 cm - 5 cm from top of reservoir after pump has run and hydraulic hoses have been primed to allow fluid to expand when heated.

DIGITAL VACUUM GAUGE ADJUSTMENT

Digital vacuum gauge is factory calibrated. However, vacuum varies throughout manifold system and it may be necessary to adjust digital readout to match actual vacuum at meter.

Load seed discs with seed and compare digital vacuum gauge readouts to reading taken from analog gauges or a hand held gauge at several meters along length of planter. Elbow connections located on covers of seed meters allow testing of meter vacuum levels without removing vacuum hoses.



Digital vacuum gauge

If there is more than 1" or 2" (H₂O) difference, adjust digital gauge by inserting a small flat bladed screwdriver into opening on back of digital gauge housing and turning potentiometer until digital gauge displays vacuum present at meter. Compare readings at 10" and 20" of vacuum.

CHECK VALVE

A check valve is located in each vacuum fan motor block assembly and operates as a return line check to prevent vacuum fan motor reverse operation. Check valves are also located in valve block on left wing and trap oil flow in planter's lift system to keep toolbar level during field operation. Another check valve is located in junction block on left wing of planter on 24 Row 70 cm. Remove and inspect valve. If it does not operate properly. Check for foreign material and if O-ring is leaking internally. Replace if defective.



DENTENT LEVER VALVE

Detent lever valve, located near tower assembly on R.H. side of machine, blocks oil flow from master cylinders until slave cylinders are at same height as master cylinders when planter is being lowered from transport into field position. Contact your Kinze Dealer for service.

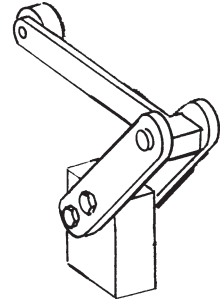

FLOW CONTROL VALVES

Two flow control valves are located in valve block on right wing of planter. Flow control valves should be adjusted for row marker raise and lower speed as part of assembly procedure or upon initial operation. If valve fails to function properly or requires frequent adjustment, it should be removed for inspection. Check for foreign material and contamination on valve and seating areas of valve body. Replace defective components.

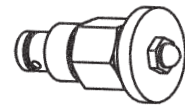

PRESSURE RELIEF VALVES

Pressure relief valve in valve block on left wing of planter functions during lowering out of raised transport sequence. Valve is factory set and should require no additional adjustment. Pressure relief valve located in valve block on tongue functions during tongue extend cycle. This pressure relief valve ensures latch cylinder extends and releases prior to tongue extending. Valve is factory set and should require no additional adjustment. Contact your Kinze Dealer for service.

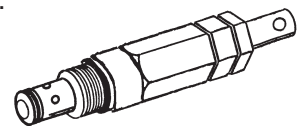
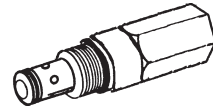

NOTICE

Connect hydraulic motor case drain to a case drain return line with zero pressure on tractor or hydraulic motor will be damaged. DO NOT connect hydraulic motor case drain to SCV outlet. Contact tractor manufacturer for specific details on "zero pressure return".

RELIEF VALVE CARTRIDGE

Pressure relief valve located in vacuum fan motor block assembly helps prevent damage to vacuum fan motor by limiting pressure in the motor case drain line. It is set to open at 35 PSI (241 kPa). If valve fails to function properly, it should be removed for inspection. Check for foreign material and contamination on valve and the seating area of valve body. Replace if defective.



SOLENOID VALVE

Solenoid valve consists of a chambered body with an electric coil actuated cartridge valve.

If solenoid or solenoids fail to operate, first determine if problem is electrical or hydraulic. If valve is working properly, a click will be heard when solenoid coil is energized and valve stem opens. If no sound is heard, check solenoid coil by touching top of coil housing with a metallic object such as a pliers or screwdriver. If coil is working properly, coil housing will be strongly magnetized when energized. If voltage to coil is low it will be weakly magnetized when energized and no click will be heard.

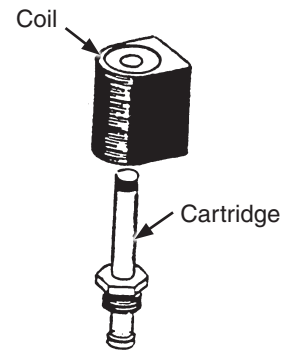

STROKE LIMITER VALVE

Stroke limiter valve, located near tower assembly on L.H. side of machine, limits height planter will raise during turn around when planter is in field operation. Contact your Kinze Dealer for service.

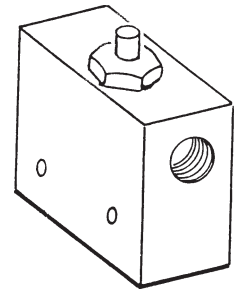

CHAIN TENSION ADJUSTMENT

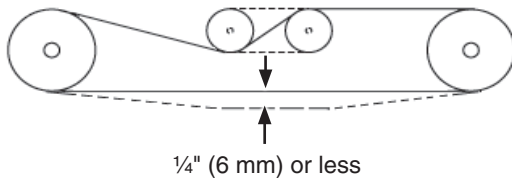

Chain link storage location (each wing)

Most drive chains have a spring loaded idler and are self-adjusting. The only adjustment needed is to shorten chain if wear stretches chain and reduces spring tension. Check idler pivot point periodically to ensure they rotate freely.

On chains with slotted idlers for adjustment, adjust so chain has 6 mm or less sag at longest span. See "Wrap Spring Wrench Assembly" for additional information.

Additional chain links can be found in the storage area located at end of planter frame on inboard side of transport hook.

STROKE LIMITER (HEIGHT STOP) VALVE ADJUSTMENT

Field turn around height of toolbar should measure 99 cm - 104 cm from ground if stroke limiter valve is correctly adjusted.

1. Lower planter to ground and hold hydraulic lever for 15-20 seconds to rephase system.

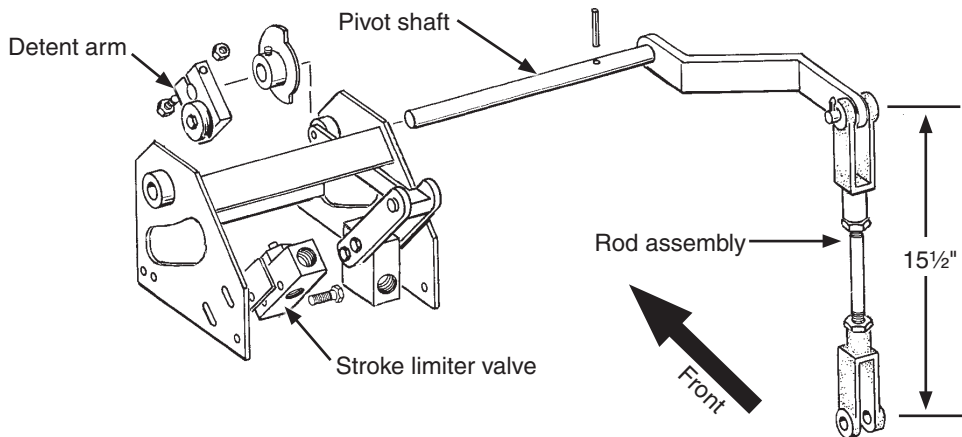

2. Check rod assembly adjustment bolt is set at $15\frac{3}{4}$ " (400 mm) pin to pin when planter is fully lowered. Adjust as needed.

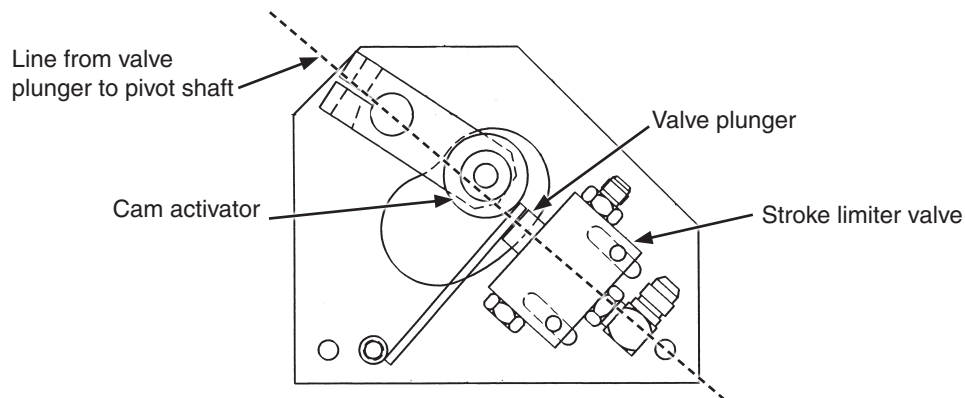

3. Check stroke limiter (height stop) valve plunger is depressed and pointing in a straight line to center of pivot shaft on cam activator.
4. Loosen detent arm (height stop assembly) clamping bolt and rotate detent arm over depressed stroke limiter valve plunger. Valve plunger should be fully depressed when detent arm is rotated over plunger arm, but must not bind. If binding occurs, move valve assembly away from detent arm while keeping valve plunger aligned with pivot shaft. Slide stroke limiter valve up or down in slotted mounting holes as needed to adjust. Tighten stroke limiter valve mounting bolts and recheck adjustment. Be sure detent arm is positioned as shown and tighten detent arm clamping bolt.
5. Raise planter until stroke limiter valve (height stop assembly) halts lift cylinder. Toolbar should measure 99 cm - 104 cm from ground. If adjustment is needed, loosen detent arm clamping bolt and rotate detent arm counterclockwise to reduce and clockwise to increase lift height. Tighten clamping bolt and mark a line on detent arm and cam activator shaft for easier alignment later.

NOTE: When lowering from transport position, planter toolbar should level out to a height of 99 cm - 104 cm from ground at field turn around. If it doesn't, rephase and/or remove air from the hydraulic lines and recheck toolbar height. Repeat above adjustments as needed.

DETENT LEVER (LOWERING CONTROL) VALVE ADJUSTMENT

Center of planter should drop until toolbar is level and then entire planter should lower evenly when lowering planter for field operation from transport position if detent lever valve is correctly adjusted.

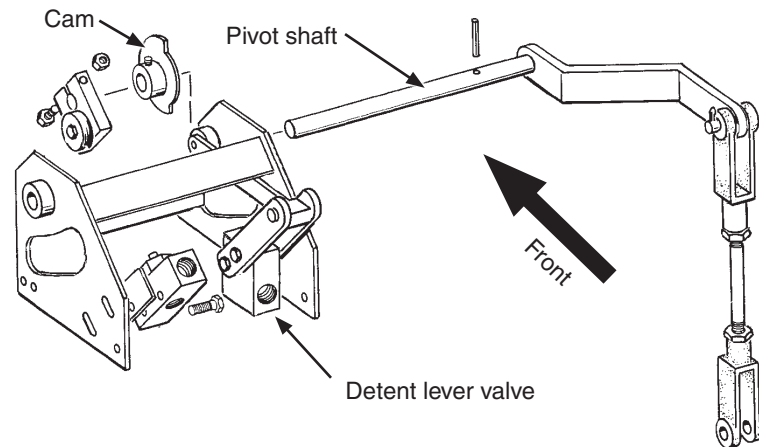

1. Raise planter to field turn around position and check toolbar height is 99 cm - 104 cm. Adjust following procedure for stroke limiter valve adjustment. Stroke limiter (height stop) valve must be correctly adjusted prior to adjusting detent lever (lowering control) valve.

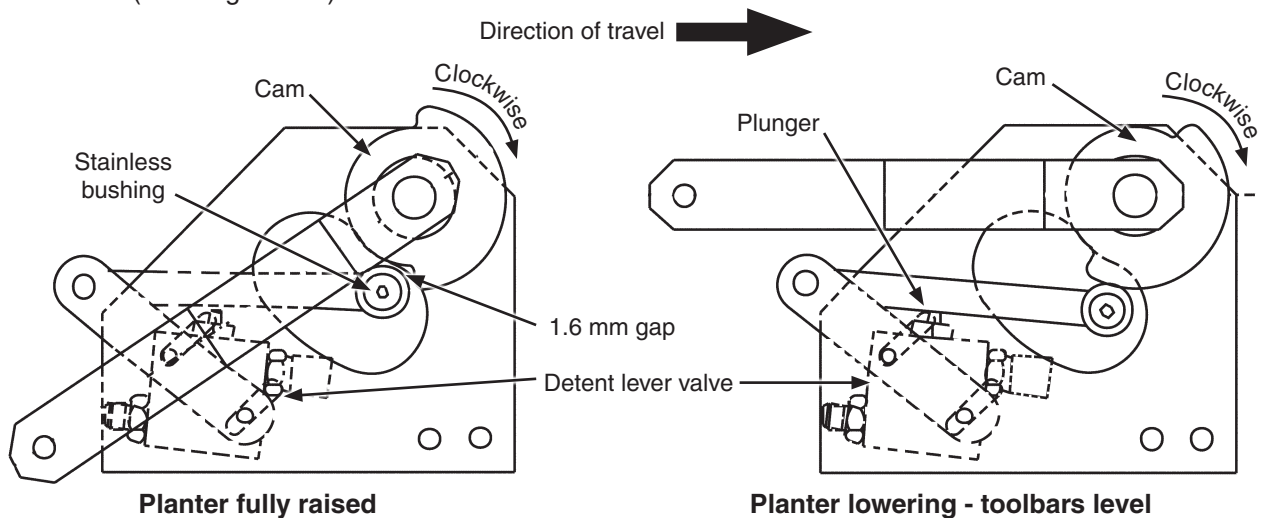

2. Raise planter to fully raised position. With cam positioned as shown, adjust detent lever (lowering control) valve in its mounting slots so there is 1.6 mm gap between stainless bushing and cam. Lower edge of cam must be above pivot point of stainless bushing.

NOTE: While lowering planter, center cylinders should begin to retract while wing cylinders stay extended. When toolbar becomes level, large radius of cam should cause arm to depress plunger on detent lever valve allowing wing cylinders to start retracting.

3. Lower planter. If center of planter drops lower than wings, loosen set screws and rotate cam clockwise. If wing cylinder begins to retract too early and wings drop lower than center of planter, rotate cam counterclockwise. Adjust cam with planter in raised position.
4. After final adjustment, remove one set screw and drill a depression in cam activator shaft with a ¼" drill bit. Reinstall set screw and repeat with second set screw. This prevents cam from slipping on pivot shaft.

ROW MARKER BEARING LUBRICATION OR REPLACEMENT

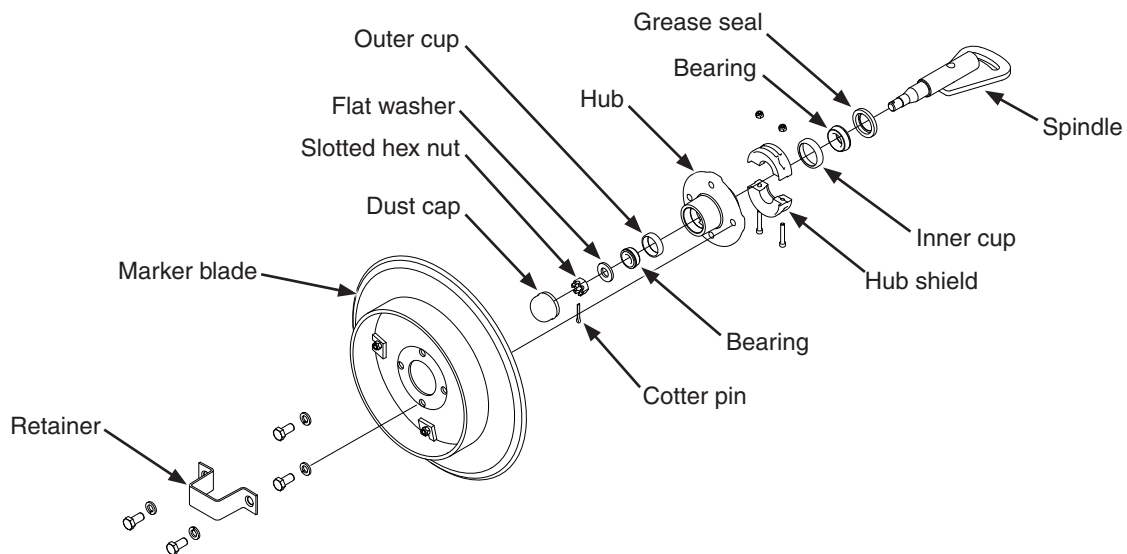

1. Remove retainer and marker blade.
2. Remove dust cap from hub.
2. Remove hub shield. Note direction of installation.
3. Remove cotter pin, slotted hex nut, and washer.
4. Slide hub from spindle.
5. Remove bearings and cups and discard if bearings are being replaced. Clean hub and dry. Remove bearings only and not cups if repacking.
6. Press in new bearing cups with thickest edge facing in. (Bearing replacement procedure only.)
7. Pack bearings with heavy duty wheel bearing grease thoroughly forcing grease between roller cone and bearing cage. Fill the space between the bearing cups in the hub with grease.
8. Install rubber seal into grease seal. Place inner bearing in place and press in new rubber seal/grease seal.
9. Clean spindle and install hub.
10. Install outer bearing, washer and slotted hex nut. Tighten slotted hex nut while rotating hub until there is some drag. This ensures all bearing surfaces are in contact. Back off slotted nut to nearest locking slot and install cotter pin.
11. Fill dust caps approximately $\frac{3}{4}$ full of wheel bearing grease and install on hub.
12. Install hub shield.
13. Install marker blade and retainer on hub. Tighten hardware evenly.

 WARNING	<p>Uncontrolled machine movement can crush or cause loss of control resulting in death, serious injury, or damage to property and equipment. Install all safety lockup devices before working under or transporting this equipment.</p>
--	---

LIFT/GROUND DRIVE WHEEL BEARING REPACK OR REPLACEMENT

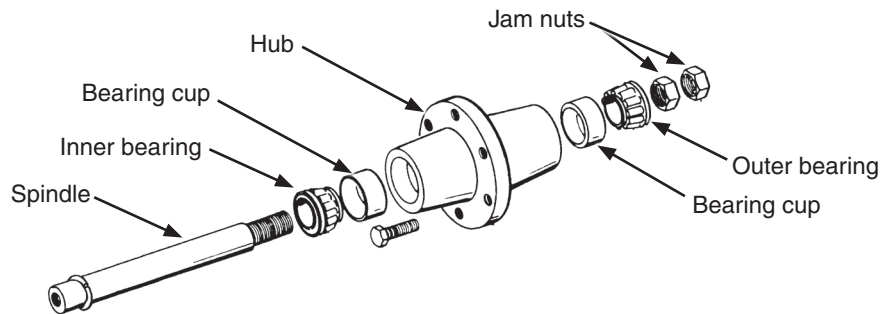

1. Raise tire clear of ground and remove wheel.
2. Remove double jam nuts and slide hub from spindle.
3. Remove bearings and cups and discard if bearings are being replaced. Clean hub and dry. Remove bearings only and not cups if repacking.
4. Press in new bearing cups with thickest edge facing in. (Bearing replacement procedure only.)
5. Pack bearings with heavy duty wheel bearing grease thoroughly forcing grease between roller cone and bearing cage. Fill space between bearing cups and hub with grease.
6. Place inner bearing in place.
7. Clean spindle and install hub.
8. Install outer bearing and jam nut. Tighten jam nut while rotating hub until there is some drag. This ensures all bearing surfaces are in contact. Back off jam nut $\frac{1}{4}$ turn or until there is only slight drag when rotating hub. Install second jam nut to lock against first.
9. Install wheel on hub. Tighten hardware evenly.

**WARNING**

Uncontrolled machine movement can crush or cause loss of control resulting in death, serious injury, or damage to property and equipment. Install all safety lockup devices before working under or transporting this equipment.

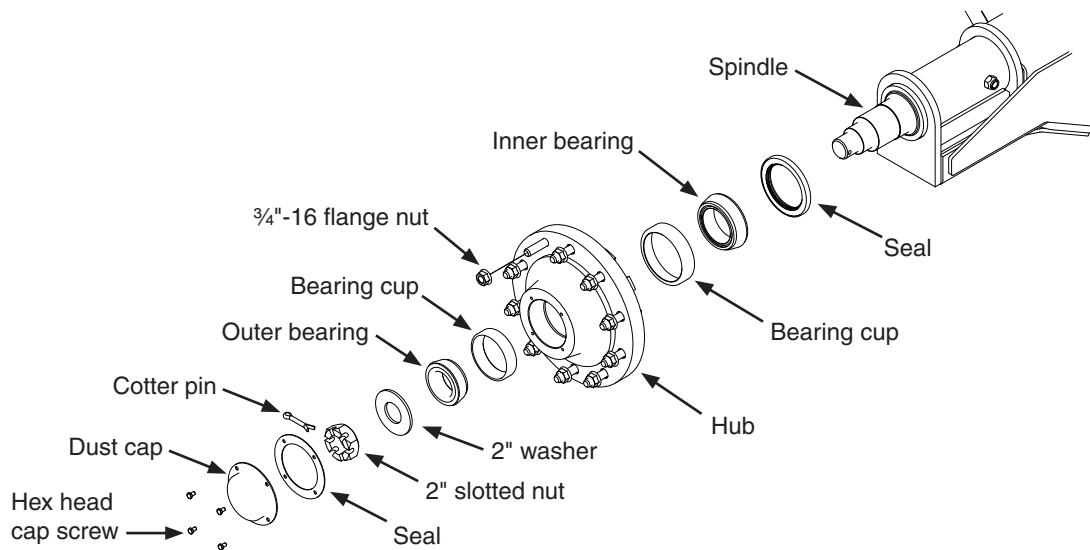
TRANSPORT WHEEL BEARING REPLACEMENT

1. Raise tires clear of ground and support with jack stand. Remove wheels.
2. Remove dust cap attachment hardware and cap from wheel hub.
3. Remove cotter pin, slotted nut, and 2" washer.
4. Slide hub from axle spindle. Use a hub puller if necessary.
5. Remove bearings and cups from hub and discard. Thoroughly clean and dry wheel hub.
6. Press in new bearing cups with thickest edges facing in.
7. Pack bearing with heavy-duty wheel bearing grease. Thoroughly force grease between roller cone and bearing cage. Fill space between bearing cups and hub with grease.
8. Place inner bearing in hub and press in new grease seal with lip pointing towards bearing.
9. Clean axle spindle and install hub.
10. Install outer bearing, 2" washer, and slotted nut. Tighten slotted nut while rotating hub until there is some drag. This ensures all bearing surfaces are in contact. Back off slotted nut to nearest locking slot and install cotter pin. Check bearing endplay.
11. Fill dust cap half full of wheel bearing grease and install on hub with four hex head cap screws.
12. Install wheels and remove jack stand. Torque $\frac{3}{4}$ " flange nuts to 380 Nm.

FERTILIZER CHECK VALVE CLEANING AND REPAIR

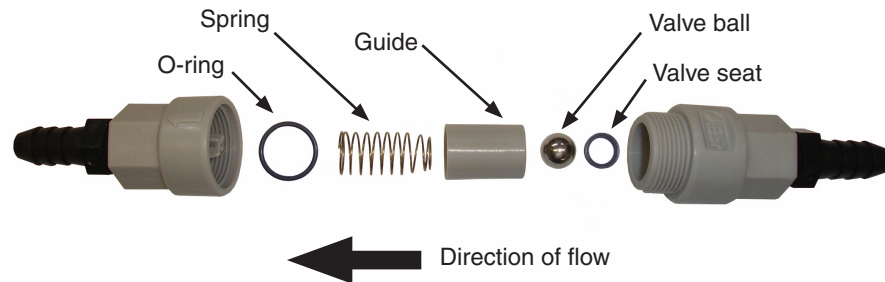

1. Unscrew valve body and separate halves. Note direction and location of parts.
2. Clean and inspect parts. Flush with clean water. Replace damaged parts.
3. Reassemble exactly as shown. O-ring and valve seat must be firmly in place inside each half of valve body.

LOW-RATE LIQUID FERTILIZER SYSTEM

Clean strainers daily.

Flush all lines with water for 30 to 60 seconds then drain water before storage.

PNEUMATIC DOWN PRESSURE AIR COMPRESSOR TANK

Moisture should be drained daily from the tank. Tank should be drained completely for storage.

To drain tank, locate drain plug on the bottom of tank. Stand off to the side of tank and pull cable attached to drain.

NOTE: If moisture is not drained from tank rust particles will form inside tank.

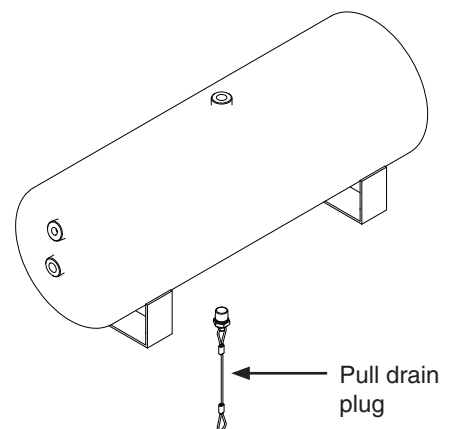

PREPARATION FOR STORAGE

- Store planter in a dry sheltered area if possible.
- Remove all trash wrapped on sprockets or shafts and remove dirt that can draw and hold moisture.
- Clean all drive chains and coat with a rust preventative spray, or remove chains and submerge in oil.
- Lubricate planter and row units at all lubrication points.
- Inspect planter for parts that in need of replacement and order during “off” season.
- Make sure all seed and granular chemical hoppers are empty and clean.
- Remove seed discs from seed meters, clean and store meters in a rodent-free, dry area with discs removed. Store seed discs vertically on a dowel or pipe.
- Remove vacuum hose from each seed meter. Operate vacuum fan at full hydraulic flow from tractor for two minutes to clear manifolds, hoses and fittings of dust and debris.
- Clean breather on analog vacuum and pressure gauges.
- Disassemble, clean and grease all U-joint slides.
- Grease or paint disc openers/blades and row marker disc blades to prevent rust.
- Flush liquid fertilizer tanks, hoses and metering pump with clean water. See “Piston Pump Storage” if applicable.
- Empty dry fertilizer hoppers. Clean hoppers. Disassemble and clean metering augers. Reassemble, coating all metal parts with rust preventative.

PISTON PUMP STORAGE

NOTICE

Keep air out of the pump! This is the only way to prevent corrosion. Even for short periods of storage, the entrance of air into the pump causes **RAPID and SEVERE CORROSION**. Freezing temperatures can cause the fluid or water to freeze internally to the pump, which can cause severe damage to the wet-end castings.

OVERNIGHT

Suspension fertilizer must be flushed from the pump for ANY storage period. For Clear Liquids:

1. Steady or rising temperatures: leave pump and hoses filled with solution. DO NOT DRAIN nor admit air to the pumps.
2. Cooling weather: (solution likely to salt out), fill pump with water and leave filled. DO NOT admit air.
3. Freezing temperature: fill pump with RV-antifreeze and leave filled, DO NOT admit air.

ONE TO TWO WEEKS

ACCEPTABLE: Flush pump thoroughly with 5 to 10 gallons of a solution that will neutralize the liquid last pumped (refer to that manufacturer's instructions). Fill with clean water and DO NOT DRAIN. Keep pump sealed to exclude air. If freezing temperatures are remotely possible, the winter storage procedure (see below) must be used to avoid damage to the pump castings.

PREFERRED: Flush pump as detailed above. IMMEDIATELY fill all passages in pump with straight RV antifreeze which contains a rust inhibitor. Place 1-1/2" NPT PVC plugs in the suction and discharge fittings to keep pump full and exclude air.

WINTER STORAGE

1. Flush pump as detailed above.
2. With pump set on 10, draw in straight RV-antifreeze until the discharge is clean. If system utilizes a flow divider (FD), pump the RV-antifreeze through the FD manifold until it is seen in the discharge lines. Fill pump and plug suction and discharge fittings of pump to retain RV-antifreeze.

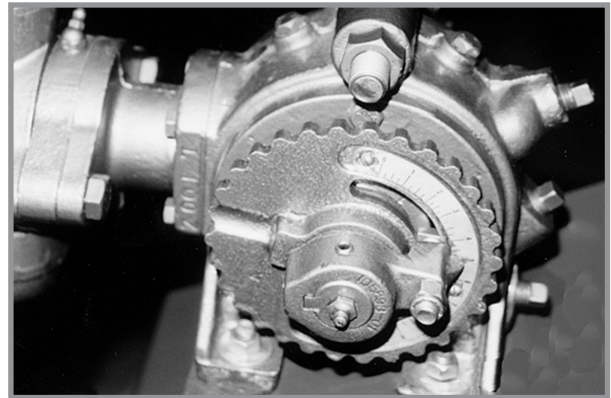
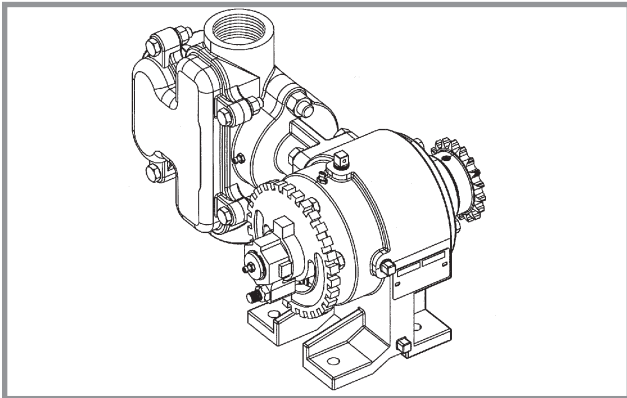

Liquid fertilizer piston pump

ELECTRICAL WIRING DIAGRAM FOR LIGHTING PACKAGE

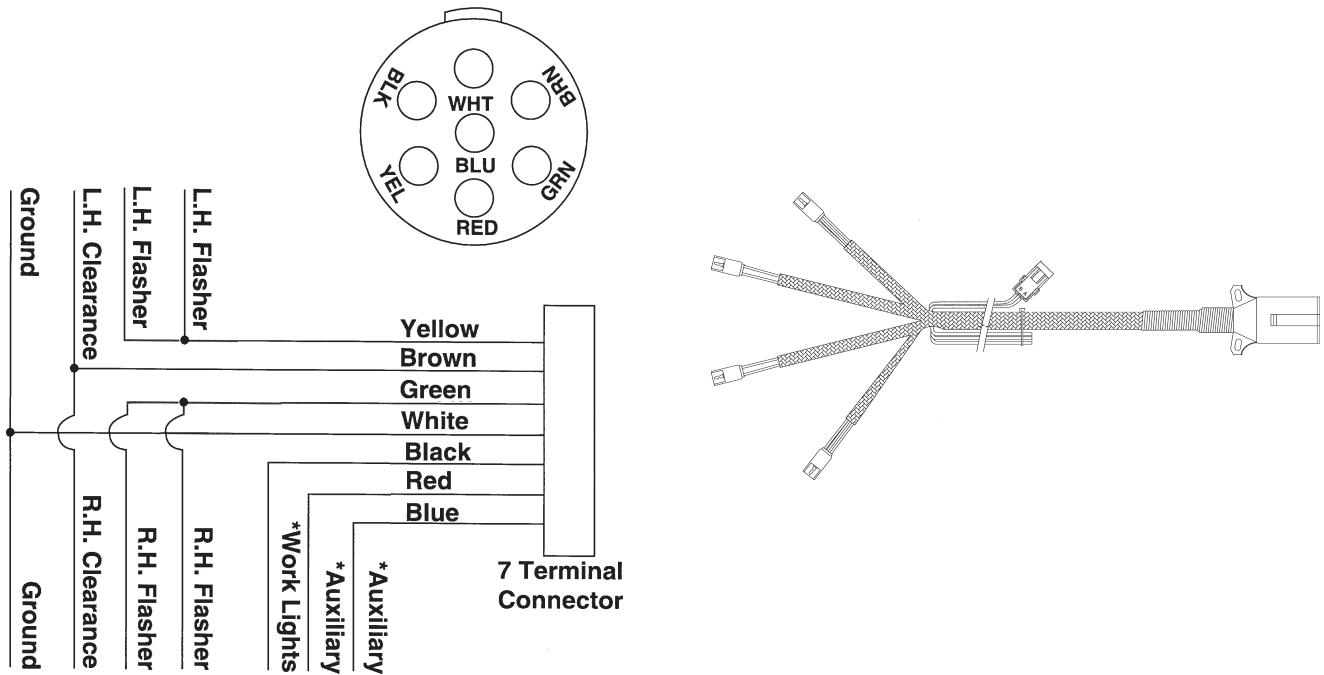

Light packages supplied on Model 3705 Front Folding Planters meet ASABE Standards. Check with tractor manufacturer for correct wiring harness to be wired into lights on your tractor, .

***Optional customer-supplied auxiliary lights and wires may be wired into existing plug terminals.**

ELECTRICAL CONTROL CONSOLE SCHEMATIC

NOTICE

Disconnect control console from tractor battery before doing any electrical work or shorting will damage equipment. Keep wiring harnesses away from high temperature areas or sharp edges. **DO NOT** route wiring harnesses along battery cables. Use cable ties to keep wire harness away from moving parts on tractor and planter. Ground connections to tractor frame must be clean to provide good electrical contact.

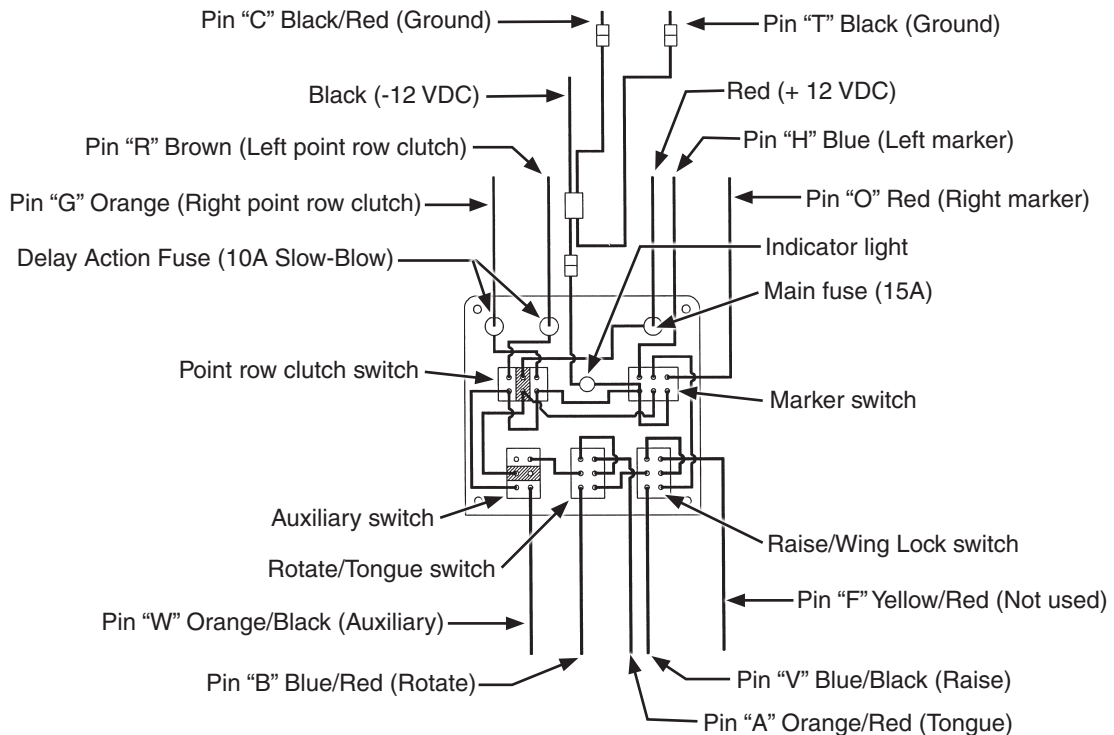
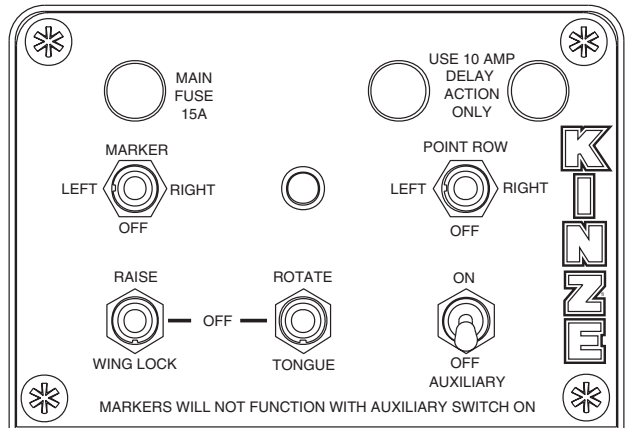

NOTE:

1. Operating row marker or point row switch in either direction lights panel light.
2. Point row clutch switch operates independently from rest of control box.
3. Power to row marker switch is fed through auxiliary switch and two transport function switches. Operating any switch in lower row disables row marker function and turns off panel light. (If point row clutch switch is "OFF".)

ELECTRICAL WIRING HARNESS SCHEMATIC (ON TRACTOR)

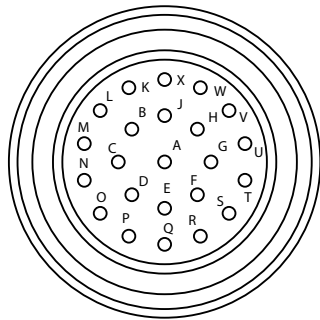

Pin No.	Wire Color	Function	Wire Ga.
A	Orange/Red	Tongue Raise	14
B	Blue/Red	Fold	14
C	Black/Red	Ground	14
D	White	Monitor B 12V	14
E	Green	Monitor B DATA	14
F	Yellow/Red	Wing Lock	14
G	Orange	Point Row - Right	12
H	Blue	Marker - Left	14
J	Black	Monitor B Ground	14
K	White	Monitor A 12V	14
L	Green	Monitor A DATA	14
M	Black	Monitor A Ground	14
N	---	---	---
O	Red	Marker - Right	14
P	---	---	---
Q	---	---	---
R	Brown	Point Row - Left	12
S	Yellow	Reduced Rate - Left	12
T	Black	Ground	12
U	Red/Black	Reduced Rate - Right	12
V	Blue/Black	Raise to Transport	14
W	Orange/Black	Auxiliary	14
X	---	---	---

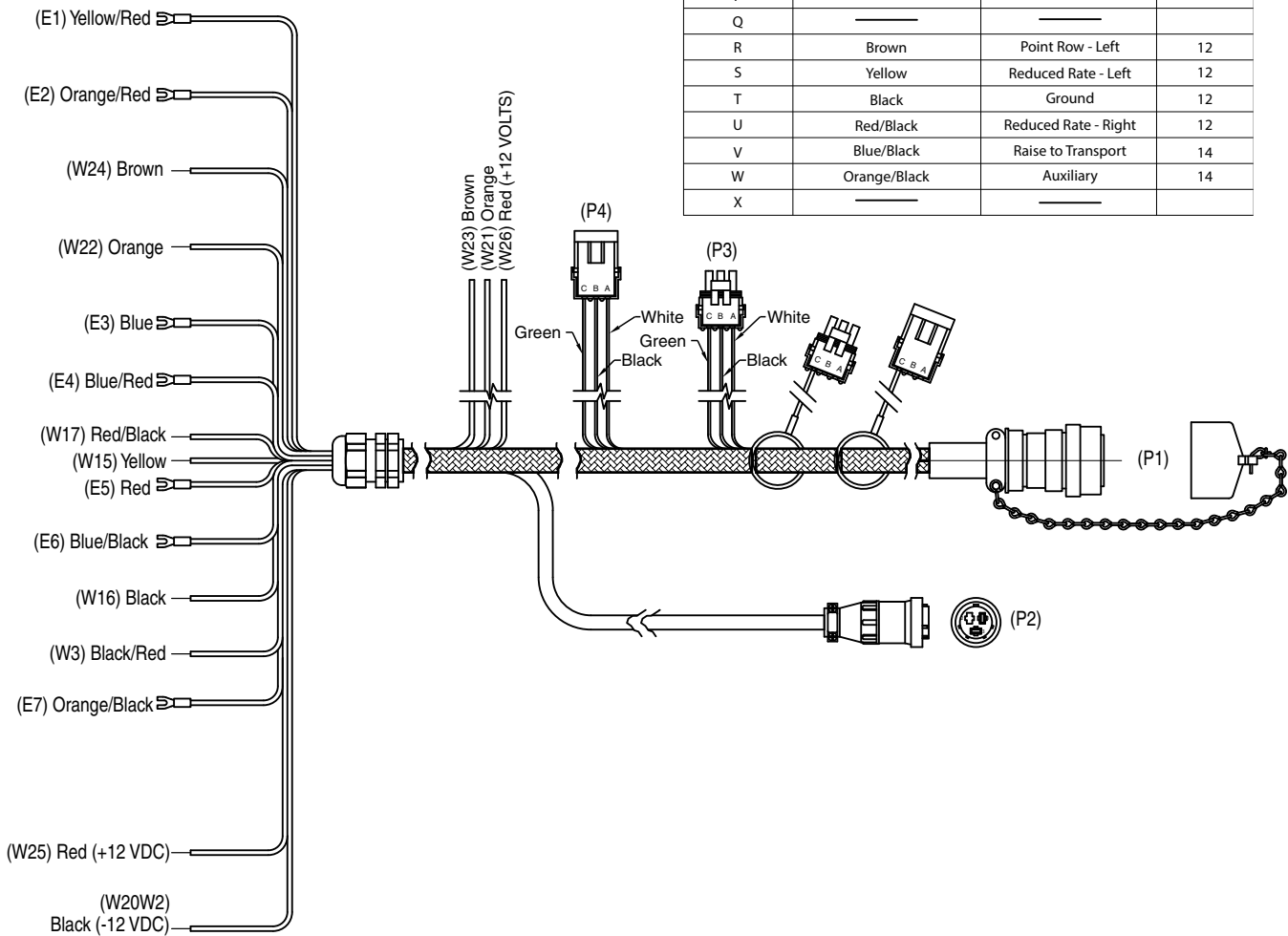

ELECTRICAL WIRING HARNESS SCHEMATIC (ON PLANTER)

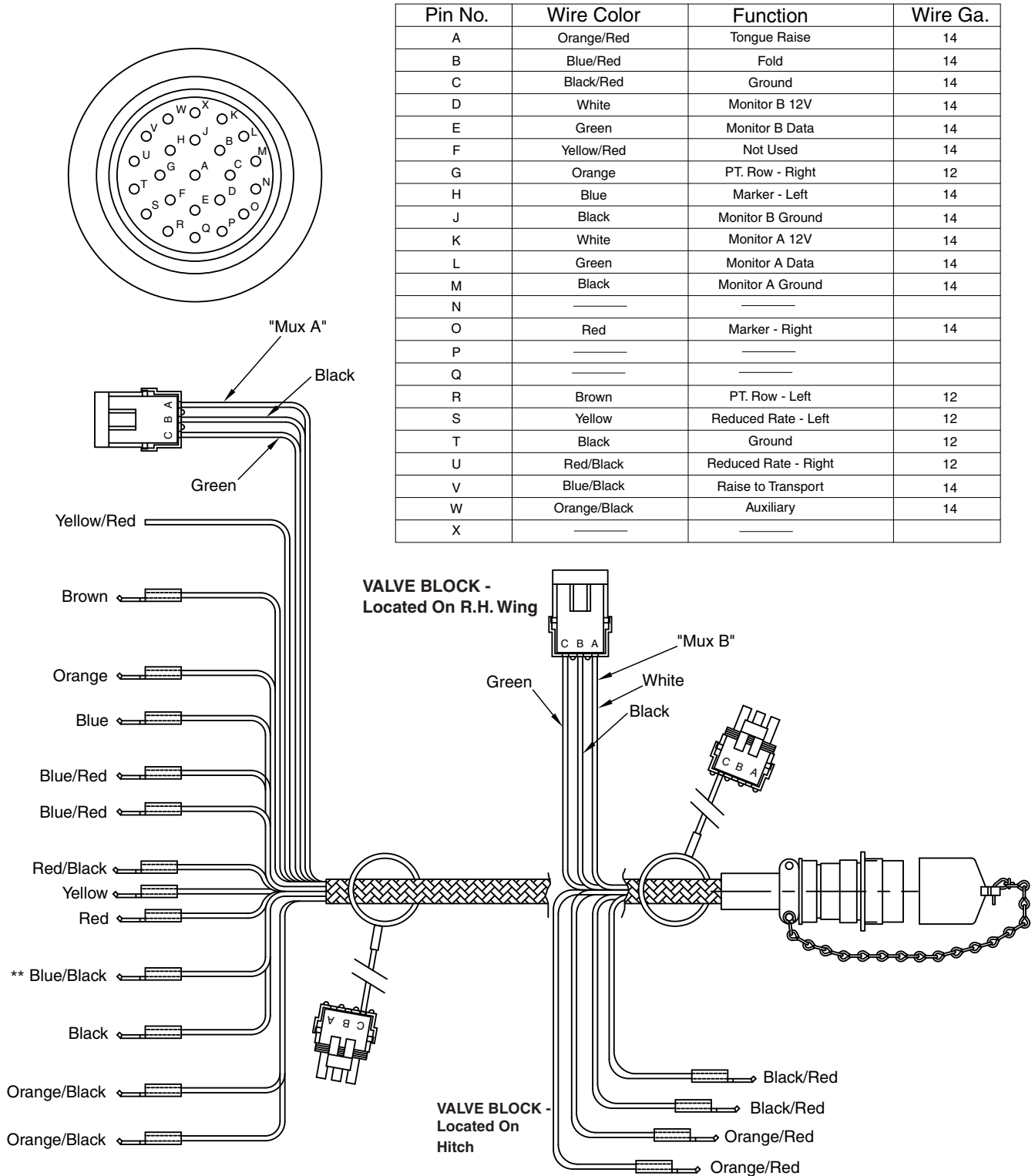

** NOTE: Harness To Port V14 On Valve Block Located On Tower

VALVE BLOCK - LOCATED ON HITCH

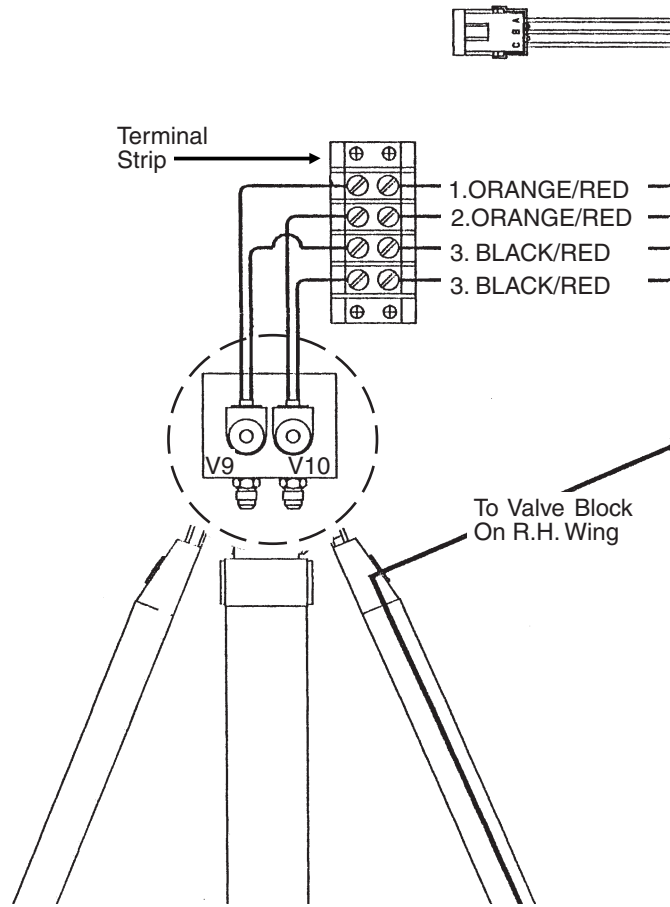

- 1. ORANGE/RED - Pin "A" (Tongue Retract/Extend) - Port V9
- 2. ORANGE/RED - Pin "A" (Tongue Retract/Extend) - Port V10
- 3. BLACK/RED - Pin "C" (Ground)

VALVE BLOCKS - LOCATED ON TOWER AND R.H. WING

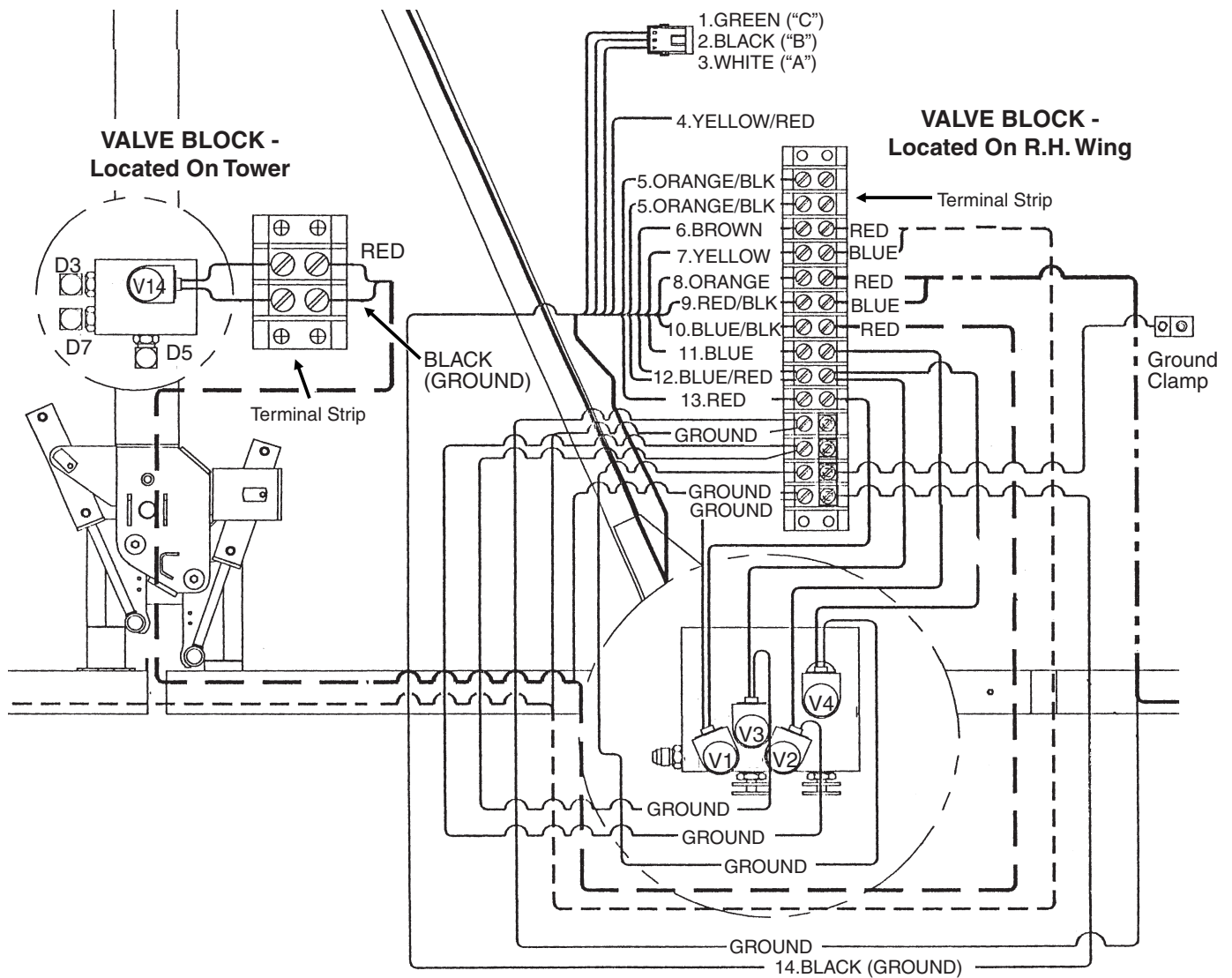

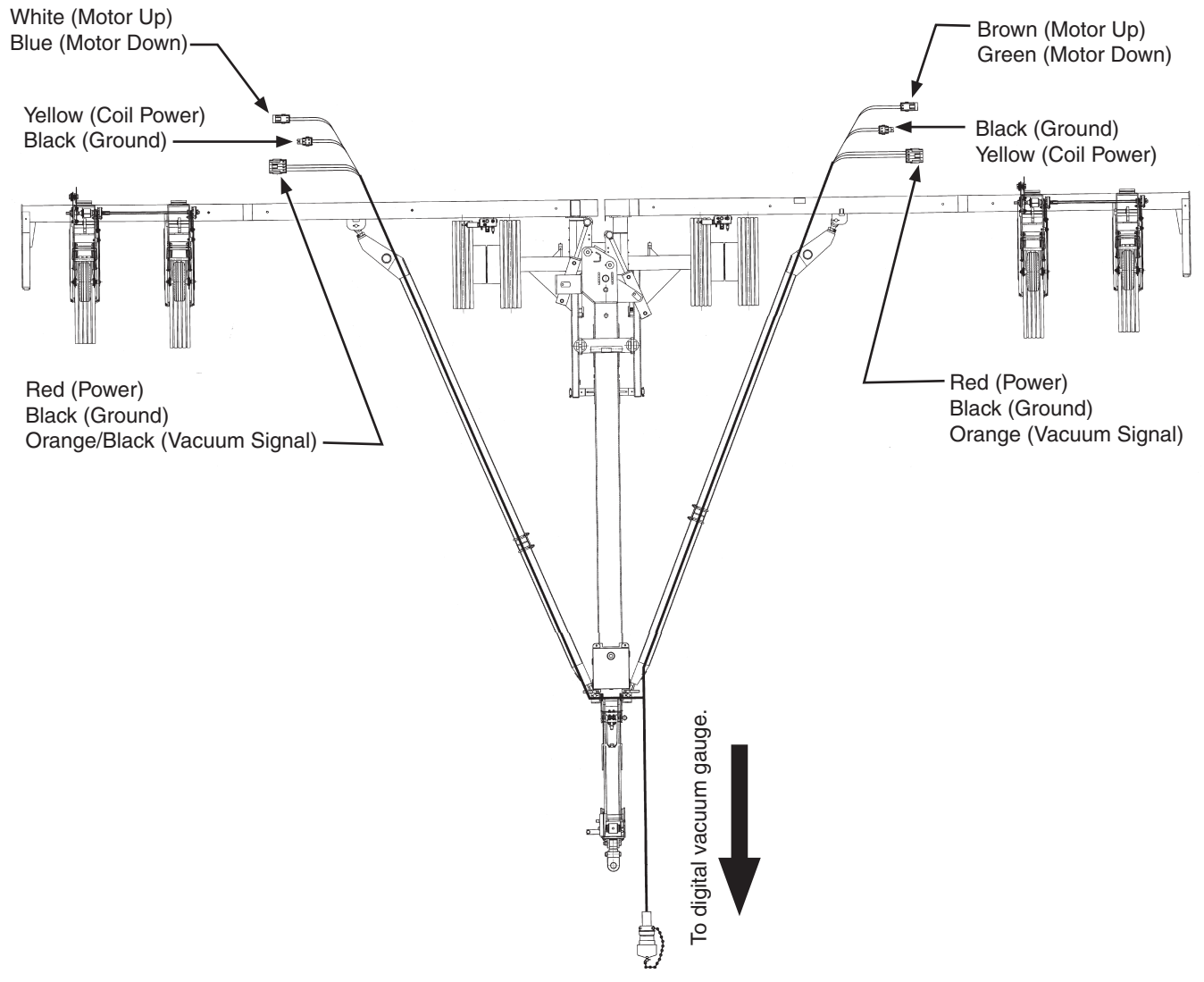

1. GREEN - Pin "L" ("C" MONITOR DATA)
2. BLACK - Pin "M" ("B" MONITOR GROUND)
3. WHITE - Pin "K" ("A" MONITOR +12V)
4. YELLOW/RED - Pin "F" (NOT USED)
5. ORANGE/BLACK - Pin "W" (Auxiliary)
6. BROWN - Pin "R" (L.H. Point Row Clutch)
7. YELLOW - Pin "S" (L.H. Two-Speed Clutch)*
8. ORANGE - Pin "G" (R.H. Point Row Clutch)
9. RED/BLACK - Pin "U" (R.H. Two-Speed Clutch)*
10. BLUE/BLACK - Pin "V" (Raise)
11. BLUE - Pin "H" (L.H. Marker) - Port V2
12. BLUE/RED - Pin "B" (Rotate) - Ports V3 And V4
13. RED - Pin "O" (R.H. Marker) - Port V1
14. BLACK - Pin "T" (Ground)

ELECTRICAL WIRING HARNESS SCHEMATIC (VACUUM FAN CONTROL)



HYDRAULIC HOSE LIFE

 WARNING	Pressurized hydraulic fluid can penetrate body tissue and result in death, serious infection, or other injuries. Fluid injected under skin must be IMMEDIATELY removed by a surgeon familiar with this type of injury. Make sure connections are tight and hoses and fittings are not damaged before applying system pressure. Leaks can be invisible. Keep away from suspected leaks. Relieve pressure before searching for leaks or performing any system maintenance.
	

Proper storage of hydraulic hoses can significantly increase the life of the hoses, for a period of three to five years. After this period, service life of hoses may decrease, depending on variables such as variances in rubber materials and storage environment. Refer to the guidelines below for best practices when storing.

- Store in a clean, cool and dry area
- Avoid direct sunlight or moisture
- Do not store near high power electrical equipment
- Avoid contact with corrosive chemicals
- Avoid ultraviolet light
- Avoid areas with obvious signs of insects or rodents

Unusually long periods of storage or poor storage environment may lead to performance issues or premature failure. Always inspect all hoses prior to use for extensive wear, cuts, or holes. If such flaws are identified, replace immediately to avoid potential failure, property damage or bodily injury.

HYDRAULIC SCHEMATIC (VACUUM FAN SYSTEM) 24 ROW 70 CM

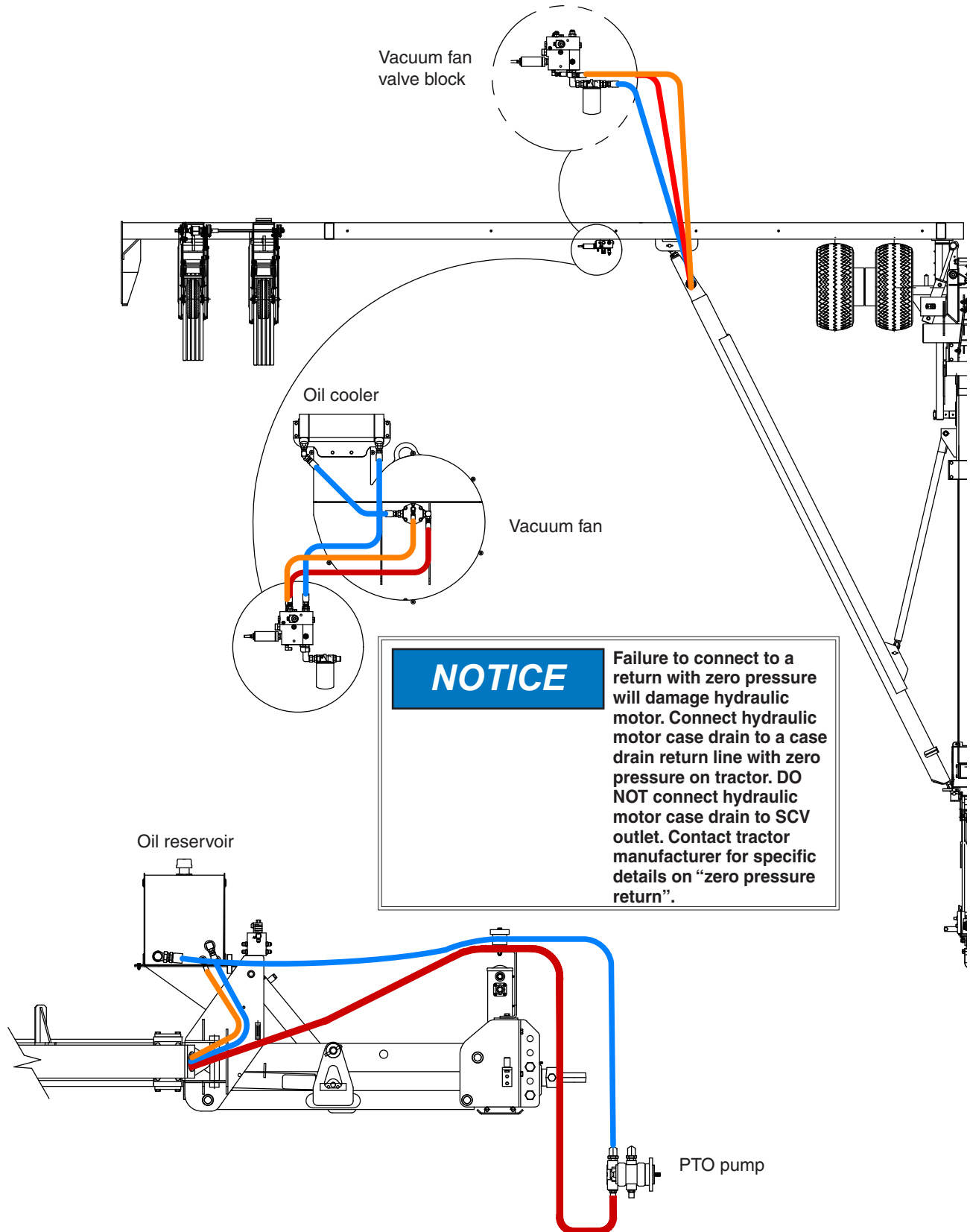

NOTICE Failure to connect to a return with zero pressure will damage hydraulic motor. Connect hydraulic motor case drain to a case drain return line with zero pressure on tractor. DO NOT connect hydraulic motor case drain to SCV outlet. Contact tractor manufacturer for specific details on "zero pressure return".

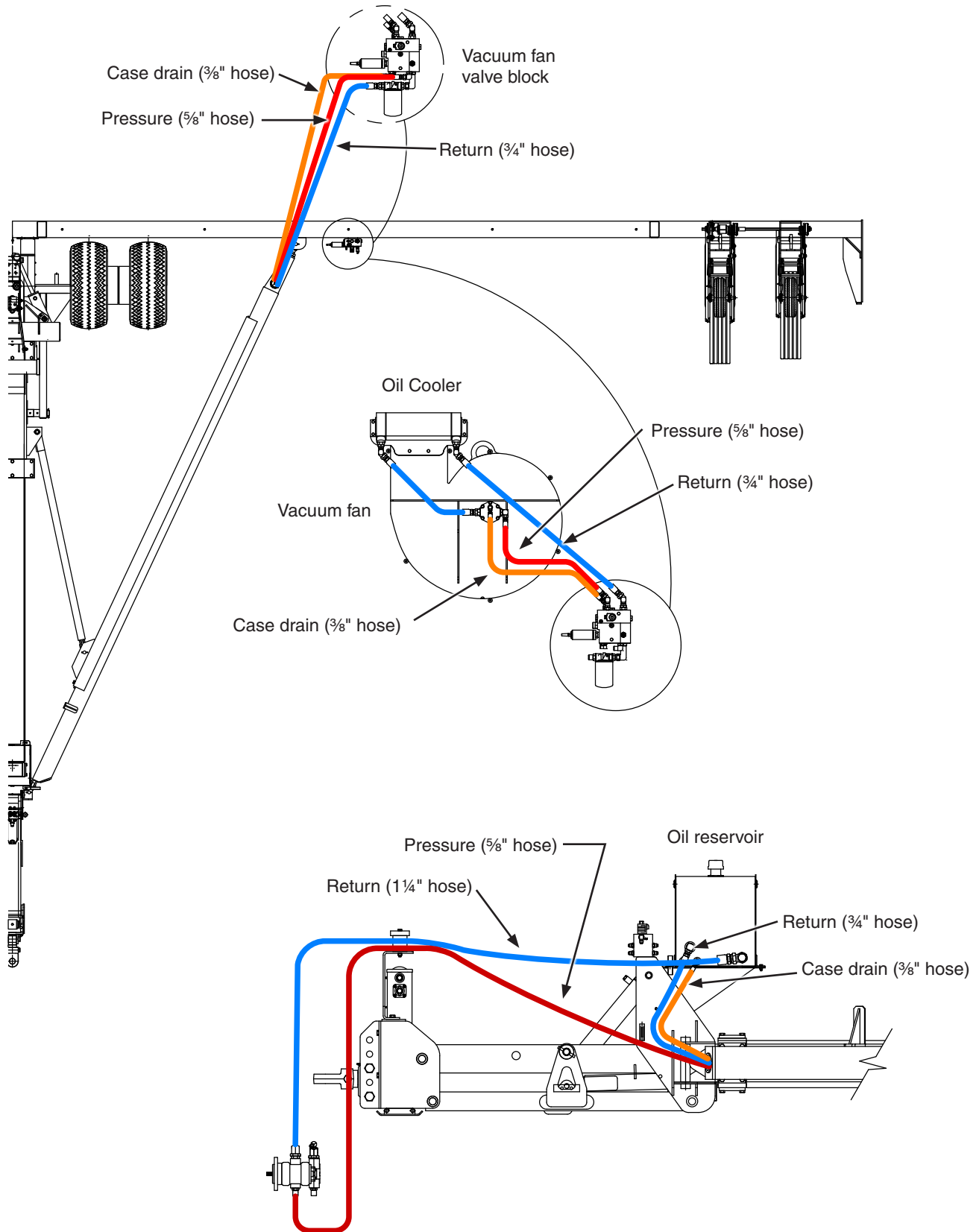

HYDRAULIC SYSTEM SCHEMATIC (24 ROW 70 CM)

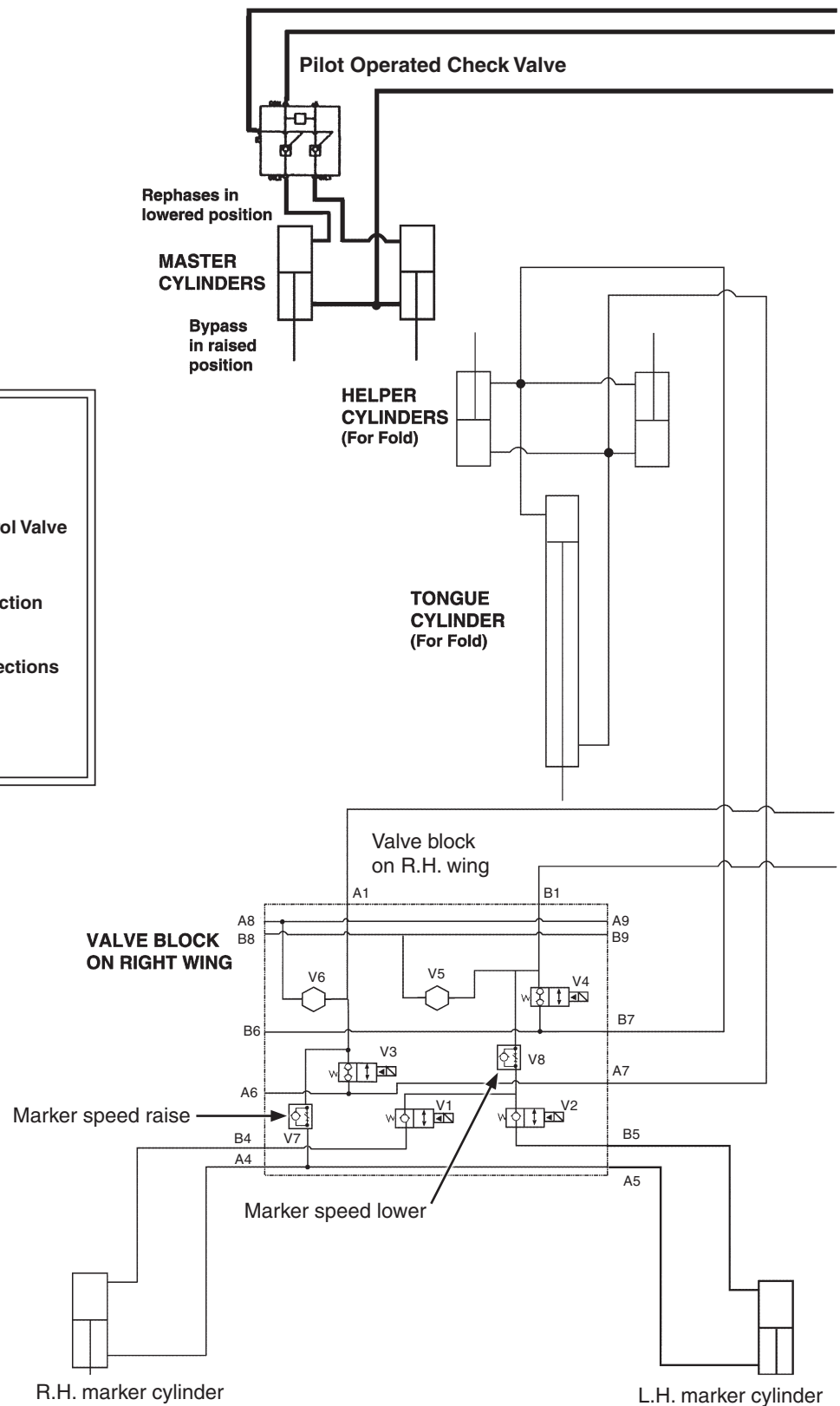
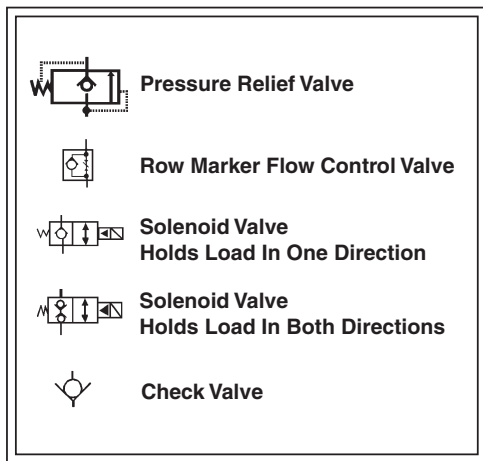

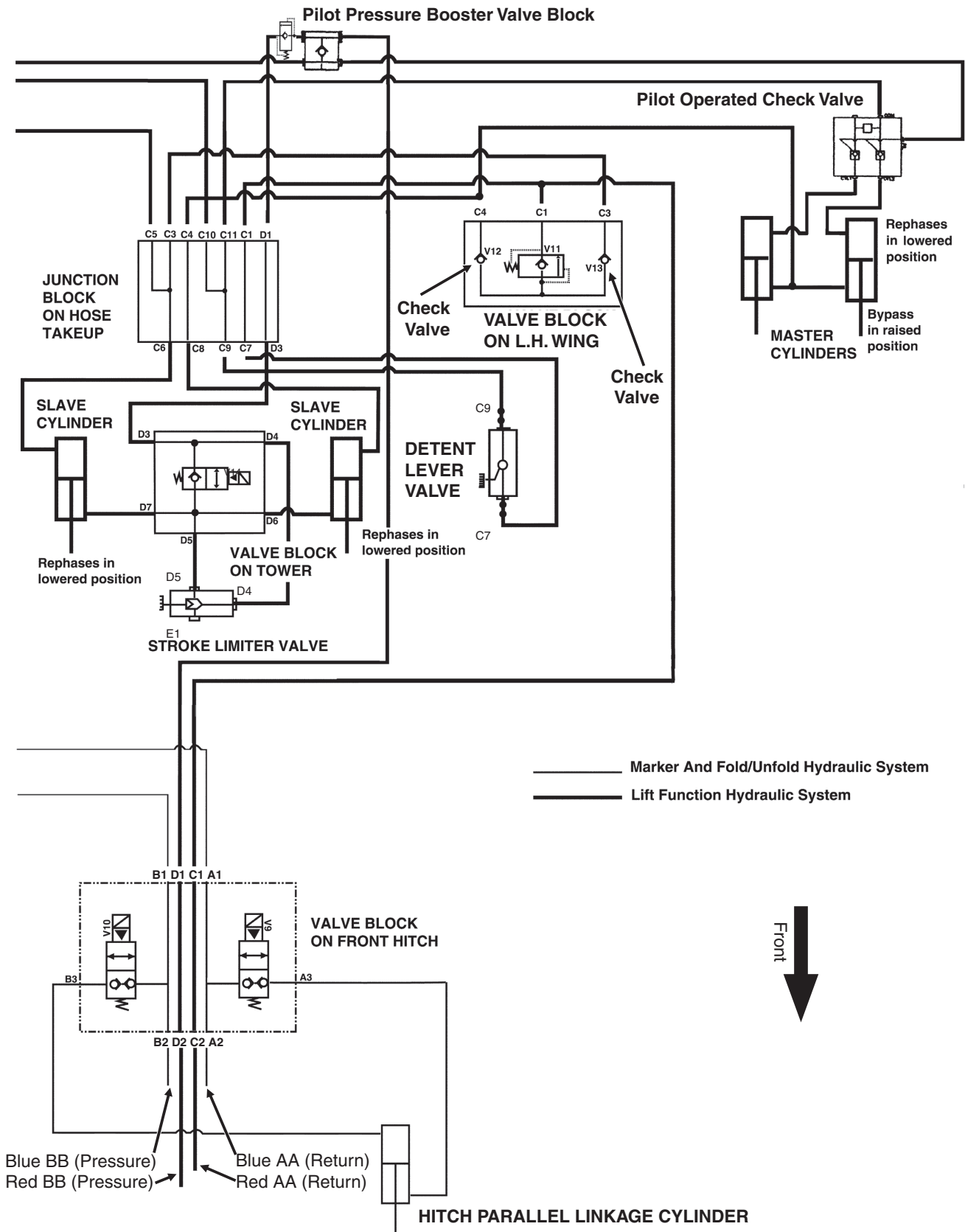

HYDRAULIC VALVE BLOCK LOCATIONS

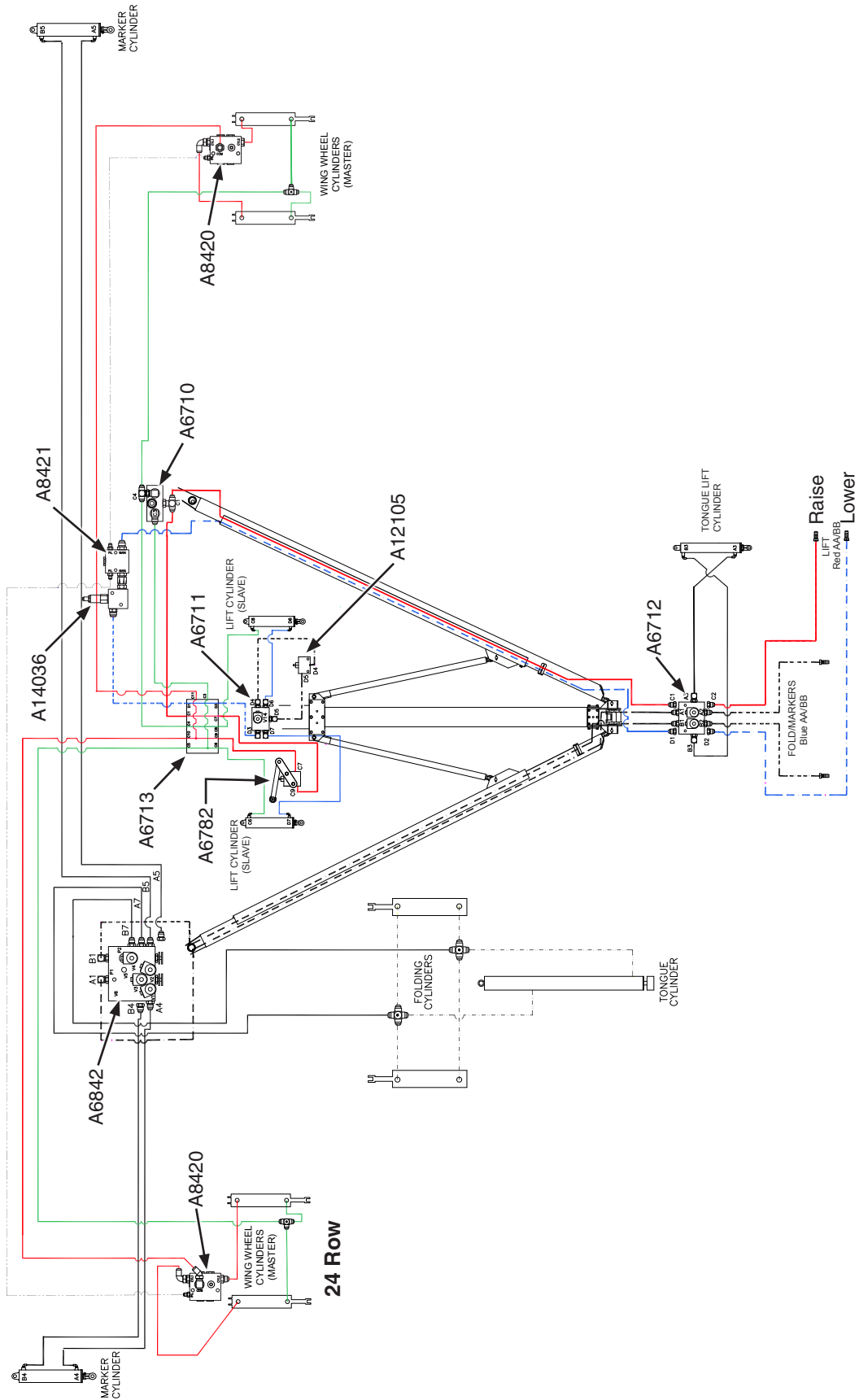

24 Row

HYDRAULIC VALVE BLOCK FUNCTIONS

Valve Assembly	Name	Function
A6710	Valve block on L.H. wing	1500 PSI relief valve. Allows lower from transport.
A6711	Valve block on tower	Oil enters D3 and flows past V14 to rod end of slave cylinders when lowering planter. Oil from rod side of slave cylinders goes in D6 and D7 when raising planter. V14 is closed so oil goes out D5 to height stop plunger and comes back in on D4 to tractor. Oil flows directly to tractor when V14 is energized and allows planter to raise to transport height.
A6712	Valve block on front hitch	Controls tongue lift cylinder and routes hydraulic hoses to left and right side drag links.
A6713	Junction block on hose take-up	Planter lift circuit junction block. Routes hydraulic flow to all planter lift related valves.
A6782	Detent Lever Valve	Blocks oil from exiting wing cylinders when lowering until center of planter reaches a predetermined height (level toolbars) and then is mechanically opened.
A6842	Valve block on R.H. wing	Controls markers and marker speed. Routes hydraulic flow to tongue and fold cylinders.
A8420	Pilot Operated Check Valve	Traps oil in butt ends of wing cylinders until pilot pressure from A8421 opens check valves and allows cylinders to retract.
A8421	Valve block on L.H. wing	Opens pilot operated check valves in A8420 when lowering.
A12105	Stroke Limiter Valve	Shuts off hydraulic flow to set field turn height.
A12113	Valve block on L.H. and R.H. wheel module (36 row 20 only)	Blocks flow from port 2 to 1 until pressure exceeds valve set pressure (1000 PSI). Allows free reverse flow from 1 to 2 if pressure at 1 is at least 10 PSI greater than pressure at 2.
A14036	Pilot Pressure Booster Valve Block	Located on inboard side of A8421 to create 1000 PSI pressure on pilot lines to ensure wing wheels lower together.

CLOSING WHEEL

PROBLEM	POSSIBLE CAUSE	SOLUTION
Closing wheel(s) leave severe imprint in soil.	Too much closing wheel down pressure.	Adjust closing wheel pressure.
Closing wheel(s) not firming soil around seed.	Not enough closing wheel down pressure.	Adjust closing wheel pressure. Severe no till conditions may require use of cast iron closing wheels.
"V" closing wheel running on top of seed furrow.	Improper centering.	Align. See "V Closing Wheel Adjustment".
Single closing wheel not directly over seed.	Improper centering.	Align. See "Covering Discs/Single Press Wheel Adjustment".

LIFT CIRCUIT

PROBLEM	POSSIBLE CAUSE	SOLUTION
Field turn around toolbar height is not 39"-41".	Stroke limiter valve is out of adjustment.	Consult your Kinze Dealer for service.
Planter not leveling out when lowering from transport.	Detent lever valve out of adjustment.	Consult your Kinze Dealer for service.
Planter settles.	Lift cylinder leaking.	Repair or replace cylinder.

PISTON PUMP

PROBLEM	POSSIBLE CAUSE	SOLUTION
Pump hard or impossible to prime.	Valves fouled or in wrong place.	Inspect and clean valves.
	Air leak in suction line.	Repair leak.
	Pump set too low.	Adjust pump setting.
	Packing washers worn out.	Replace.
Low metering.	Valves fouled or in wrong place.	Inspect and clean valves.
	Air leak in suction line.	Repair leak.
	Pump set too low.	Adjust pump setting.
	Broken valve spring.	Replace spring.
Over meters.	Broken discharge valve spring.	Replace spring.
	Trash under valves.	Inspect and clean valves.
	Improper rate setting.	Adjust pump setting.
Leaks through when stopped.	Broken discharge valve spring.	Replace spring.
	Trash under valves.	Inspect and clean valves.
Fertilizer solution leaking under stuffing box.	Packing washers worn out.	Replace.
Pump using excessive oil.	Oil seals or O-ring worn and leaking.	Replace.
Pump operates noisily.	Crankcase components worn excessively.	Inspect and replace if necessary.

STROKE LIMITER VALVE

PROBLEM	POSSIBLE CAUSE	SOLUTION
Planter will not raise.	Poppet not moving freely in adapter and mechanical stop has poppet pushed completely in with no air gap.	Remove adapter from valve block. Check movement of poppet in adapter. It should move freely. If not, remove poppet from adapter and clean seal area. Inspect poppet stem for damage.
Planter will not stop at the raised field position.	Mechanical stop arm not adjusted correctly.	Adjust mechanical stop arm.
External leak.	Worn or damaged O-rings.	Install seal kit.

SOLENOID VALVE

PROBLEM	POSSIBLE CAUSE	SOLUTION
No solenoids operate.	Low voltage.	Must be connected to 12 volt DC only. Negative ground.
	Blown fuse.	Replace control console fuse with AGC-15 amp.
	Battery connection.	Clean and tighten.
	Wiring harness damaged.	Repair or replace.
One solenoid valve will not operate.	Bad switch.	Replace on control panel.
	Cut wire in harness.	Locate and repair.
	Bad coil.	Replace.
	Poor connection at coil.	Check.
Valve operating when not energized.	Valve stem stuck open.	Replace cartridge.
	O-ring leaking.	Install new O-ring kit.
	Foreign material under poppet.	Remove and clean cartridge.

PTO PUMP DRIVE AND OIL COOLER OPTION

PROBLEM	POSSIBLE CAUSE	SOLUTION
Pump is squealing.	Lack of oil to pump.	Check for plugged suction strainer. Check oil level.
Oil temperature high.	Low oil level.	Check oil level and add as required.
Desired fan speed cannot be achieved.	Low oil level.	Check oil level and add as required.
	Plugged filter.	Check and change as required.
Vacuum level not displayed.	Digital vacuum gauge console power OFF.	Turn ON.
	Cable not plugged in.	Check connection.
	Digital vacuum gauge console has no power.	Check fuse.

POINT ROW CLUTCH

PROBLEM	POSSIBLE CAUSE	SOLUTION
No clutches disengage.	Main fuse blown in control console.	Replace defective fuse.
	Poor terminal connection in wiring harness.	Repair or replace.
	Wiring damage in wiring harness.	Repair or replace.
	Low voltage at coil. (12 volts required)	Check battery connections.
One section of planter will not re-engage.	Shear pin at seed drive transmission(s) sheared.	Replace pin with one of equal size and grade.
One clutch will not engage.	Fuses blown.	Replace defective fuses.
	Actuator arm and plunger stuck in disengaged position.	Remove, free up, and reinstall.
	Actuator arm out of adjustment.	Adjust actuator arm mounting pin in slot so that actuator arm clears stop on stop collar by approximately " when clutch is rotated.
	Wrap spring broken or stretched.	Disassemble clutch and replace spring.
	Something touching the stop collar.	Check to ensure collar is free to turn with clutch.
	Clutch assembled incorrectly.	Check clutch and diagram for correct assembly.
Clutch slipping.	Wrap spring stretched.	"Lock" clutch output shaft from turning. Place torque wrench on input shaft and rotate in direction of drive. After input shaft has rotated a short distance the wrap spring should tighten onto the input hub. If slippage occurs at less than 100 ft. lbs. replace spring. If spring still slips after installing new spring, replace input hub.
Planter section does not re-engage while planter is moving forward.	Spring in actuator arm not strong enough to push arm operational switch is turned to the ON position.	Remove spring from inside solenoid and stretch spring slightly or replace. Reinstall spring. If that fails, file the away from stop collar when stop on the stop collar slightly so that the stop is not as aggressive.
Frequent solenoid burnout.	Fuses too large.	Replace fuses on front panel with 10 amp slow blow fuses.
Frequent fuse burnout.	Low voltage (12 volts required).	Check power source voltage for partially discharged battery, etc.
	Damage to wiring harness.	Repair or replace harness.
Clutch or clutches will not disengage.	Input and output shafts out of alignment.	Align input and output shafts to prevent drag.
	Input or output shaft is pushed in too far creating a coupler.	Reposition input and output shafts.

ROW MARKER OPERATION

PROBLEM	POSSIBLE CAUSE	SOLUTION
Right marker lowering slower than left marker.	Solenoid valve cartridge in port V1 not opening completely.	Switch with cartridge in port V2. If problem repeats, replace cartridge.
	Hose pinched or collapsed.	Inspect hose routing. Replace or repair hoses as required.
Left marker lowering slower than right marker.	Solenoid valve cartridge in port V2 not opening completely.	Switch with cartridge in port V1. If problem repeats, replace cartridge.
	Hose pinched or collapsed.	Inspect hose routing. Replace or repair hoses as required.
Both markers lowering.	Solenoid valve cartridge stuck open. If left marker switch is selected, right cartridge (V1) is defective. If right marker switch is selected, left cartridge (V2) is defective.	Replace solenoid valve cartridge.
Neither marker lowers.	Blown fuse.	Check red light on control console. It should be on if switch is on. If light is not on, switch to opposite marker position. If light comes on, switch may be defective. Replace switch. Otherwise replace fuse.
	Coils at V1 and V2 not energized.	Poor ground on wire, bad wire connection or damaged wire. Repair as required.
	Marker flow control valve closed too far.	See "Row Marker Speed Adjustment".
Neither marker will raise.	Marker flow control valve closed too far.	See "Row Marker Speed Adjustment".
Right marker will not lower.	Solenoid coil in port V1 not energized.	Check switch on control console. Replace if defective. Check coil ground wire. Check for poor connection or damaged wire.
	Solenoid cartridge in port V1 stuck closed.	Switch cartridge with one on the planter you know is operating properly. If right marker lowers, replace defective cartridge.
Left marker will not lower.	Solenoid coil in port V2 not energized.	Check switch on control console. Replace if defective. Check coil ground wire. Check for poor connection or damaged wire.
	Solenoid cartridge in port V2 stuck closed.	Switch cartridge with one on the planter you know is operating properly. If left marker lowers, replace defective cartridge.
Markers traveling too fast and damaging rubber stop on transport stands and/or damaging pivot at rod end of marker cylinders.	Marker transport stand not adjusted correctly to allow marker cushion cylinders to operate as designed.	See "Row Marker Transport Stand Adjustment".
	Adjust row marker flow control valve.	See "Row Marker Speed Adjustment".

VACUUM SEED METER

PROBLEM	POSSIBLE CAUSE	SOLUTION
Low seed count.	Meter RPM too high.	Reduce planting rate or planting speed.
	Singulator blade setting too aggressive.	Adjust singulator blade.
	Vacuum level too low.	Increase fan speed.
	Seed sensor not picking up all seeds dropped.	Clean seed tube. Move meter to different row.
	Seeds sticking to seed disc.	Use graphite or talc to aid release.
	Seed treatment buildup in seed disc recesses.	Reduce amount of treatment used and or mix thoroughly. Add talc.
	Seed size too large for disc used.	Use appropriate disc for seed size.
	Wrong seed disc.	Use appropriate disc for seed type and size.
	Failed/worn drive components.	Inspect and replace parts as required.
	Plugged orifices in seed disc.	Inspect and clean disc. Check remnant ejector.
	Loss of vacuum at meter.	Check for foreign material between vacuum cover and disc. Inspect parts for wear/damage. Clean or replace as required.
	Seed bridging in hopper.	Add graphite to improve seed flow.
	Faulty vacuum gauge reading.	Repair/replace gauge.
	Dirt in vacuum manifold.	Check vacuum manifold for dirt and clean.
	Seed baffle (If applicable) not allowing seed flow due to bridging of seed.	Mix talc thoroughly to coat all seeds. Remove seed baffle. See Row Unit Operation section.
Seed disc worn.	Replace.	
Vacuum seal worn.	Replace.	
Not planting seed.	Seed hoppers empty.	Fill seed hopper.
	Seed tube plugged/damaged.	Clean or replace tube.
	Meter drive damaged.	Repair/replace drive components.
	Low/no vacuum.	Inspect vacuum system and repair as necessary.
	Singulator blade setting too aggressive.	Adjust singulator blade.
	Faulty vacuum gauge.	Repair/replace vacuum gauge.
	Seed bridging in hopper.	Add graphite to improve seed flow.
	Loss of vacuum at meter.	Check for foreign material between vacuum cover and disc. Inspect parts for wear/ damage. Clean and/or replace as required.
	Wrong seed disc.	Use appropriate disc for seed type and size.
	Meter drive clutch not engaged.	Engage drive clutch.
	Fan not running.	Start fan.
Dirt in vacuum manifold.	Check vacuum manifold for dirt and clean.	

VACUUM SEED METER - Continued

PROBLEM	POSSIBLE CAUSE	SOLUTION
Not planting seed. (Continued)	Seed baffle (if applicable) not allowing seed flow due to bridging of seed.	Mix talc thoroughly to coat all seeds. Remove seed baffle. Row Unit Operation section.
	High vacuum.	Adjust vacuum level to appropriate level.
	Wrong seed disc.	Replace seed disc.
	Singulator setting not aggressive enough.	Adjust singulator.
	Faulty vacuum gauge.	Check gauge line for dirt/obstruction. Repair/replace vacuum gauge.
Poor seed spacing.	Obstruction in seed tube.	Clean seed tube.
	Dirty/damaged seed disc.	Inspect seed disc for damage, foreign material in orifices or seed treatment buildup in recesses. Clean or replace.
	Wrong vacuum setting.	Adjust vacuum to appropriate level.
	Excess foreign material in seed.	Inspect and clean meter and seed discs. Use clean, undamaged seed.
	Incorrect singulator setting.	Adjust singulator to appropriate setting.
	Inconsistent driveline.	Inspect drive components for rust, misalignment, worn or damaged parts. Replace/repair as required.
	Toolbar not level or wrong height.	Adjust hitch to level toolbar and row units.
	Planting too fast for conditions.	Reduce speed.
	Rough field conditions.	Reduce speed.
Irregular seed population.	Driving too fast.	Reduce speed.
Unable to achieve desired vacuum level.	Tractor hydraulic flow set too low.	Increase flow to fan motor.
	Incorrect hydraulic connections.	Check all hydraulic connections and hose routings.
	Damaged fan components.	Inspect motor and impeller for wear/damage and repair/replace as necessary.
	Vacuum hose pinched/kinked/blocked.	Inspect air lines for any damage or obstruction. Clean air lines and manifold by removing end cap from manifold and running fan at high speed.
	Vacuum hose loose/disconnected.	Inspect and reattach all air hoses.
	Tractor not producing required hydraulic flow/pressure.	Have tractor serviced by qualified technician.
	Dirt in vacuum gauge line.	Check gauge line for dirt/obstruction and clean.