

# CORNER DUAL AUGER 1721 1521

## SPECIFICATIONS

Model	1721	1521	
Undercarriage	Tracks	Tracks	Flotation Tires
<b>Specifications</b>			
Heaped capacity*	1700 bu.	1500 bu.	1450 bu.
Unload speed - maximum**	750 bu/min	750 bu/min	750 bu/min
Total weight - empty	35,180 lbs.	31,680 lbs.	25,400 lbs.
Hitch weight - empty	5,250 lbs.	4,040 lbs.	4,040 lbs.
Hitch weight - loaded	7,380 lbs.	6,600 lbs.	6,600 lbs.
Width - overall	13'-0"	13'-0"	13'-10"
Length - overall	39'-3"	39'-3"	35'-4"
Height - overall	12'-5"	12'-5"	12'-3"
PSI capacity***	17 psi	16 psi	24 psi
<b>Tractor Requirements (minimum)</b>			
Tractor horsepower	450 hp	370 hp	
Tractor hydraulics	2 SCVs; 2,320 system psi	2 SCVs; 2,320 system psi	
<b>Features and options</b>			
Vertical auger	STD with 22" diameter flighting with a 24" diameter tube		
Horizontal auger	STD with 20" diameter flighting with a 22" diameter tube		
Gearbox	STD with bevel and spur gears, 2:1 ratio		
Drive belts	STD with two 4-band, multi-strand V-belts		
Drive sheaves	STD with 8-groove 8" diameter drive and 16" diameter driven sheaves		
PTO	STD with 1-3/4" diameter, 20 spline, 1000 rpm PTO		
Joystick control	STD ; controls four cart functions: spout tip, horizontal auger on/off, flow gate, and auger tilt		
Tracks	STD; 36" x 108" contact area	OPT; 36" x 100" contact	---
Flotation tires	N/A	---	OPT; IF1250/50R32 CFO (R1)
5-point scale package	STD	STD	
GT400 scale display	OPT	OPT	
GT560 Autolog scale display	OPT	OPT	
Remote scale readout	OPT	OPT	
Roll tarp - manual	STD	STD	
Roll tarp - electric	OPT	OPT	
Safety chains	STD	STD	
Adjustable spout	STD	STD	

\*Cart capacity and hitch weight are based on #2 corn at 15% moisture (56lb test weight). Cart capacity and hitch weight may vary based on crop type, grade, moisture and other environmental factors.

\*\*Approximate with 15% moisture corn. Bushels/minute will vary with moisture content of grain and/or PTO rpm.

\*\*\*Comparative PSI @ 3" soil penetration depth using 56 lb. test weight grain at 15% moisture at posted capacities.

### Tracks

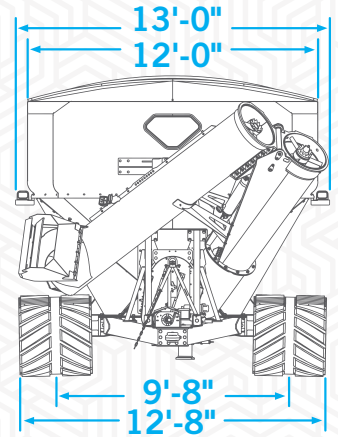

### Flotation Tires

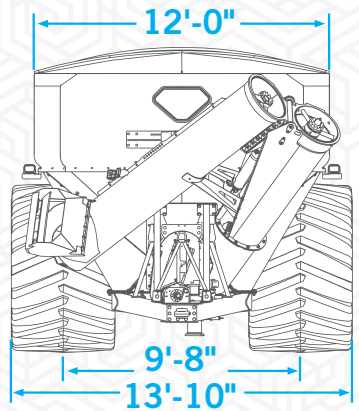

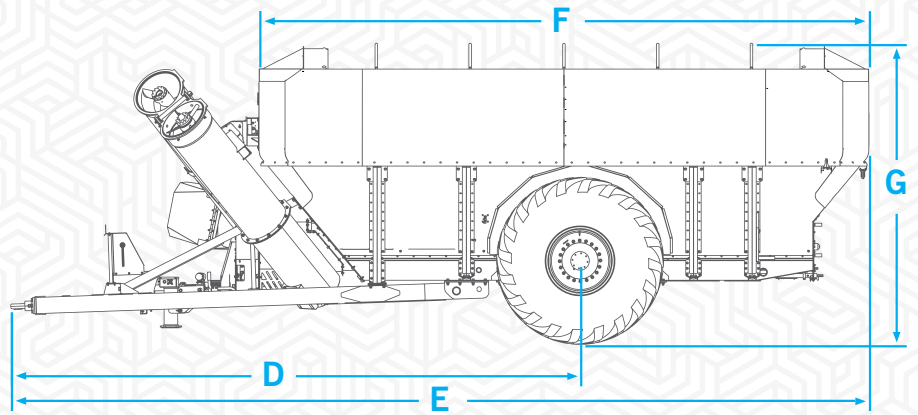
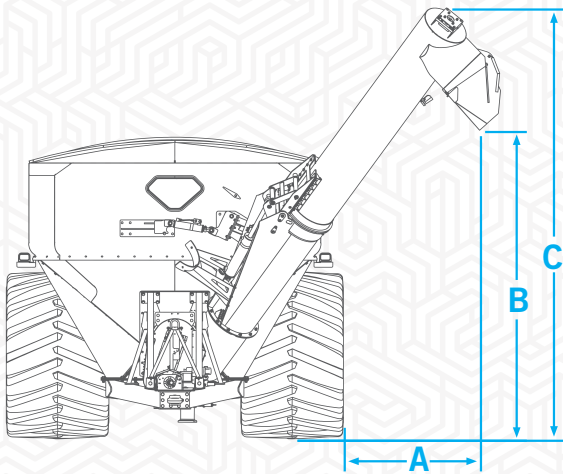
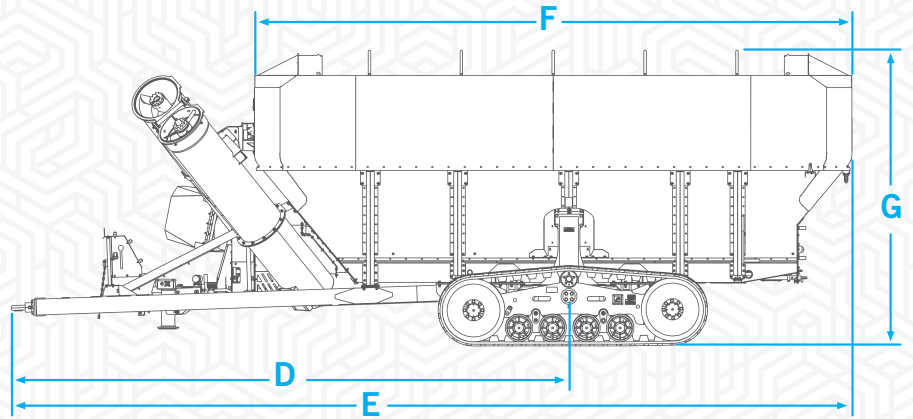
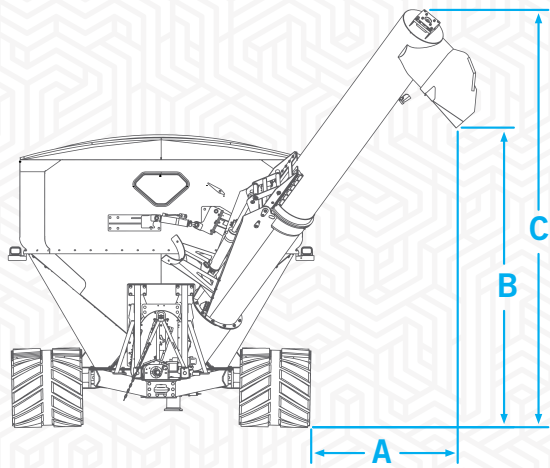

DIMENSION	1721		1521
	Tracks	Tracks	Floats
A—Auger and spout rotated down	6'-11"	6'-11"	7'-5"
A—Auger and spout rotated up	6'-9"	6'-9"	7'-1"
B—Auger and spout rotated down	10'-2"	10'-2"	10'-0"
B—Auger and spout rotated up	13'-5"	13'-5"	13'-4"
C—Auger rotated down	15'-8"	15'-8"	15'-6"
C—Auger rotated up	17'-9"	17'-9"	17'-7"
D	25'-4"	25'-4"	23'-6"
E	39'-3"	39'-3"	35'-4"
F	29'-0"	29'-0"	25'-1"
G	12'-5"	12'-5"	12'-3"



# CORNER DUAL AUGER 1421 1321

## SPECIFICATIONS

Model	1421		1321	
Undercarriage	Tracks	Flotation Tires	Tracks	Flotation Tires
<b>Specifications</b>				
Heaped capacity*	1400 bu.	1350 bu.	1300 bu.	1250 bu.
Unload speed - maximum**	750 bu/min	750 bu/min	750 bu/min	750 bu/min
Total weight - empty	31,470 lbs.	25,190 lbs.	31,000 lbs.	24,900 lbs.
Hitch weight - empty	4,000 lbs.	4,000 lbs.	3,950 lbs.	3,950 lbs.
Hitch weight - loaded	6,540 lbs.	6,540 lbs.	6,280 lbs.	6,280 lbs.
Width - overall	13'-0"	13'-10"	13'-0"	13'-10"
Length - overall	35'-4"	35'-4"	32'-0"	32'-0"
Height - overall	11'-11"	11'-9"	12'-5"	12'-3"
PSI capacity***	15 psi	23 psi	14 psi	22 psi
<b>Tractor Requirements (minimum)</b>				
Tractor horsepower	350 hp		300 hp	
Tractor hydraulics	2 SCVs; 2,320 system psi		2 SCVs; 2,320 system psi	
<b>Features and options</b>				
Vertical auger	STD with 22" diameter flighting with a 24" diameter tube			
Horizontal auger	STD with 20" diameter flighting with a 22" diameter tube			
Gearbox	STD with bevel and spur gears, 2:1 ratio			
Drive belts	STD with two 4-band, multi-strand V-belts			
Drive sheaves	STD with 8-groove 8" diameter drive and 16" diameter driven sheaves			
PTO	STD with 1-3/4" diameter, 20 spline, 1000 rpm PTO			
Joystick control	STD ; controls four cart functions: spout tip, horizontal auger on/off, flow gate, and auger tilt			
Tracks	OPT; 36" x 100" contact	---	OPT; 36" x 100" contact	---
Flotation tires	---	OPT; IF1250/50R32 CFO (R1)	---	OPT; IF1250/50R32 CFO (R1)
5-point scale package	STD		STD	
GT400 scale display	OPT		OPT	
GT560 Autolog scale display	OPT		OPT	
Remote scale readout	OPT		OPT	
Roll tarp - manual	STD		STD	
Roll tarp - electric	OPT		OPT	
Safety chains	STD		STD	
Adjustable spout	STD		STD	

\*Cart capacity and hitch weight are based on #2 corn at 15% moisture (56lb test weight). Cart capacity and hitch weight may vary based on crop type, grade, moisture and other environmental factors.

\*\*Approximate with 15% moisture corn. Bushels/minute will vary with moisture content of grain and/or PTO rpm.

\*\*\*Comparative PSI @ 3" soil penetration depth using 56 lb. test weight grain at 15% moisture at posted capacities.

### Tracks

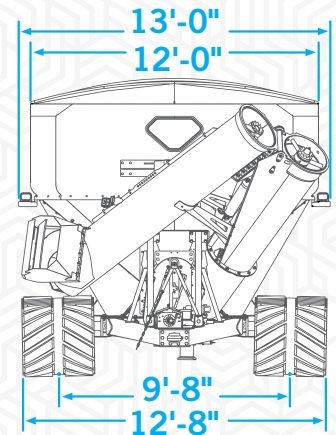

### Flotation Tires

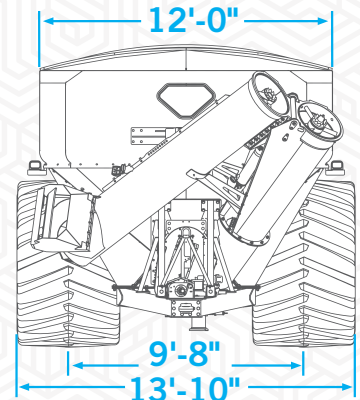

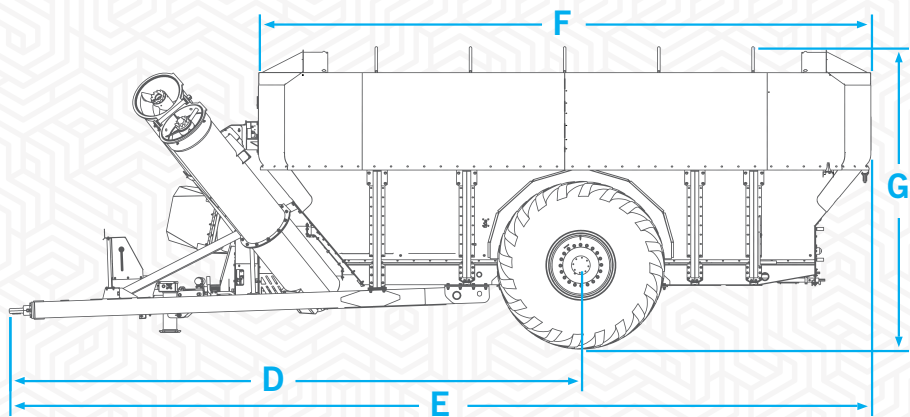
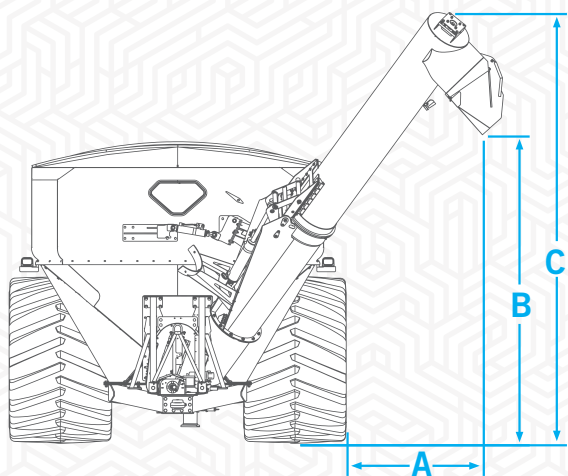
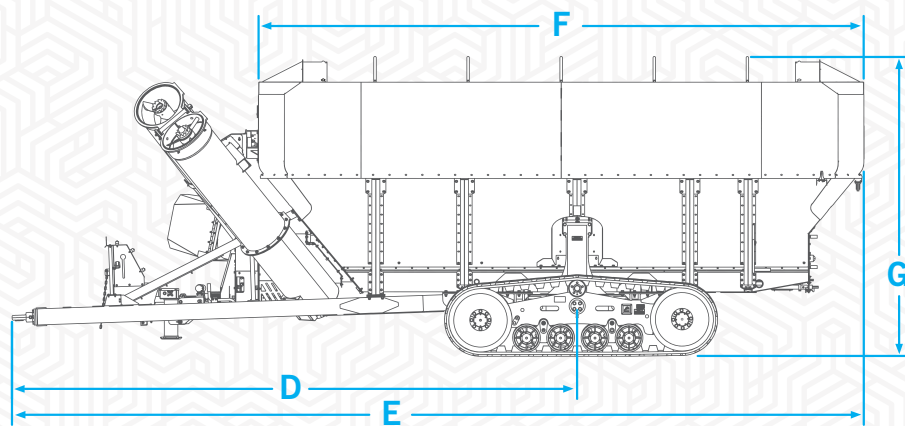
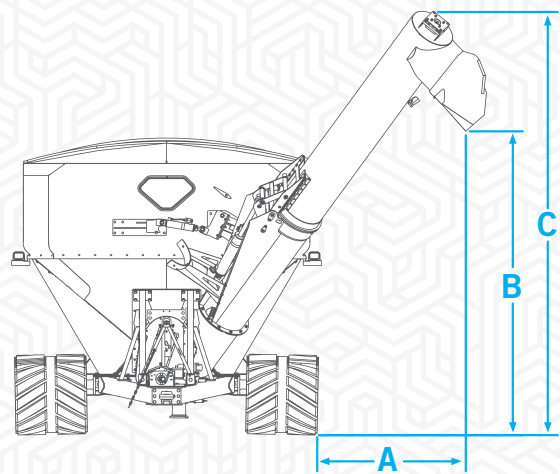

DIMENSION	1421		1321	
	Tracks	Floats	Tracks	Floats
A—Auger and Spout rotated down	6'-11"	7'-5"	6'-11"	7'-5"
A—Auger and Spout rotated up	6'-9"	7'-1"	6'-9"	7'-1"
B—Auger and spout rotated down	10'-2"	10'-0"	10'-2"	10'-0"
B—Auger and spout rotated up	13'-5"	13'-4"	13'-5"	13'-4"
C—Auger rotated down	15'-8"	15'-6"	15'-8"	15'-6"
C—Auger rotated up	17'-9"	17'-7"	17'-9"	17'-7"
D	23'-6"	23'-6"	21'-11"	21'-11"
E	35'-4"	35'-4"	32'-0"	32'-0"
F	25'-1"	25'-1"	23'-9"	10'-3"
G	11'-11"	11'-9"	12'-5"	12'-3"

Model	1121		
Undercarriage	Tracks	Flotation Tires	Row Crop Tires
<b>Specifications</b>			
Heaped capacity*	1125 bu.	1100 bu.	1100 bu.
Unload speed - maximum**	550 bu/min	550 bu/min	550 bu/min
Total weight - empty	26,620 lbs.	20,880 lbs.	21,440 lbs.
Hitch weight - empty	3,820 lbs.	3,820 lbs.	3,820 lbs.
Hitch weight - loaded	6,260 lbs.	6,260 lbs.	6,260 lbs.
Width - overall	12'-0"	12'-1"	12'-0"
Length - overall	30'-10"	30'-10"	30'-10"
Height - short side	10'-11"	11'-0"	11'-0"
Height - high side	12'-0"	12'-1"	12'-1"
PSI capacity***	12 psi	23 psi	25 psi
<b>Tractor Requirements (minimum)</b>			
Tractor horsepower	250 hp	250 hp	250 hp
Tractor hydraulics	3 SCVs; 2,320 system psi		
<b>Features and options</b>			
Vertical auger	STD with 20" diameter flighting with a 22" diameter tube		
Horizontal auger	STD with 20" diameter flighting with a 22" diameter tube		
Gearbox	STD with 90 degree, 3.5" - 4" pitch cut gears, 2:1 ratio		
Drive belts	STD with two 4-band, multi-strand V-belts		
Drive sheaves	STD with 8-groove 7-1/2" diameter drive and 15" diameter driven sheaves		
PTO	STD with 1-3/4" diameter, 20 spline, 1000 rpm PTO		
Tracks	OPT; 36" x 100" contact area	---	---
Flotation tires	---	OPT; 1245/50R32	---
Row crop tires	---	---	OPT; 480/80 R42
3-point scale package	STD	STD	STD
GT400 scale display	OPT	OPT	OPT
GT560 Autolog scale display	OPT	OPT	OPT
Remote scale readout	OPT	OPT	OPT
Roll tarp - manual	STD	STD	STD
Safety chains	STD	STD	STD
Adjustable spout	STD	STD	STD

\*Cart capacity and hitch weight are based on #2 corn at 15% moisture (56lb test weight). Cart capacity and hitch weight may vary based on crop type, grade, moisture and other environmental factors.

\*\*Approximate with 15% moisture corn. Bushels/minute will vary with moisture content of grain and/or PTO rpm.

\*\*\*Comparative PSI @ 3" soil penetration depth using 56 lb. test weight grain at 15% moisture at posted capacities.

### Tracks

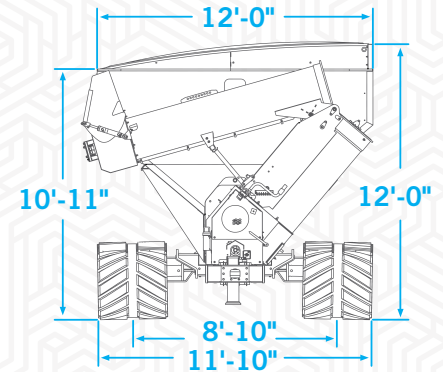

### Flotation Tires

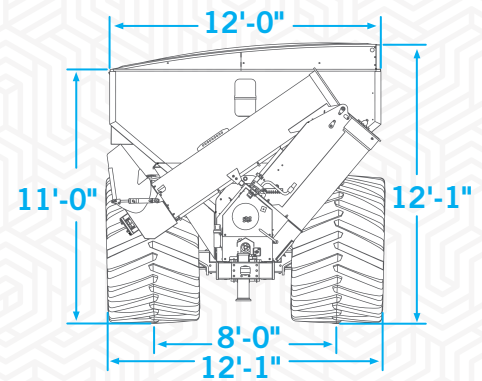

### Row Crop Tires

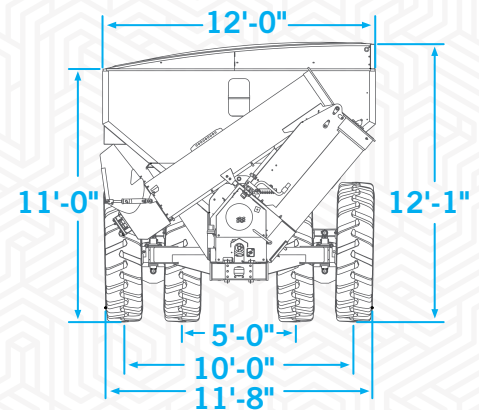

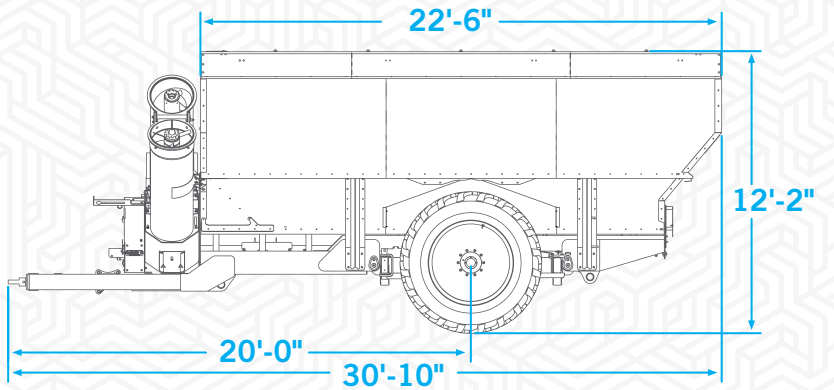
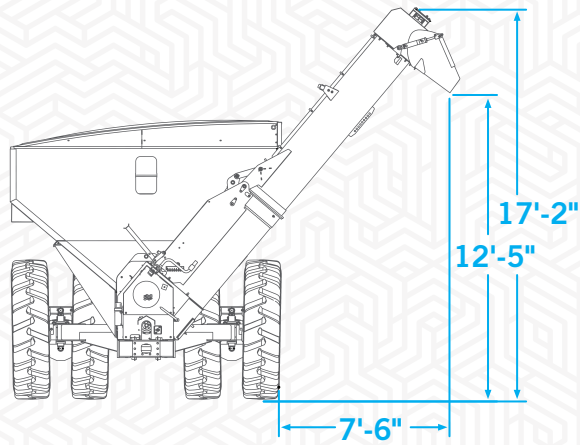
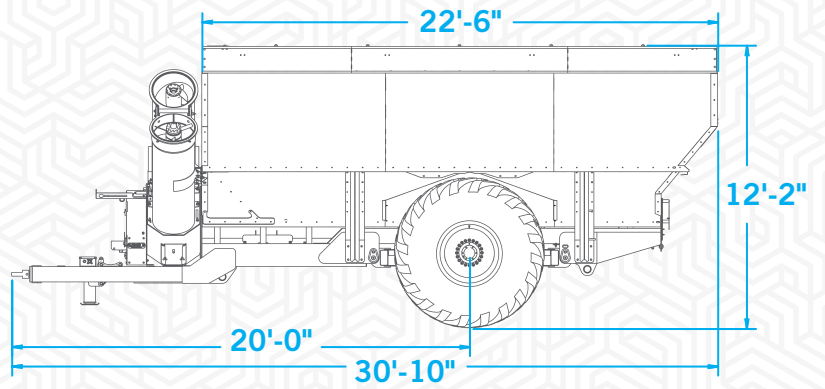
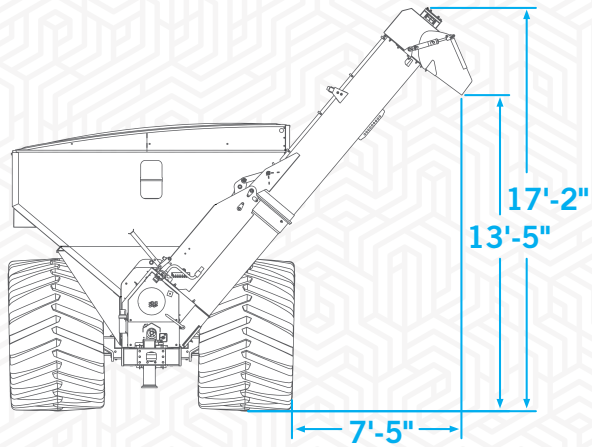
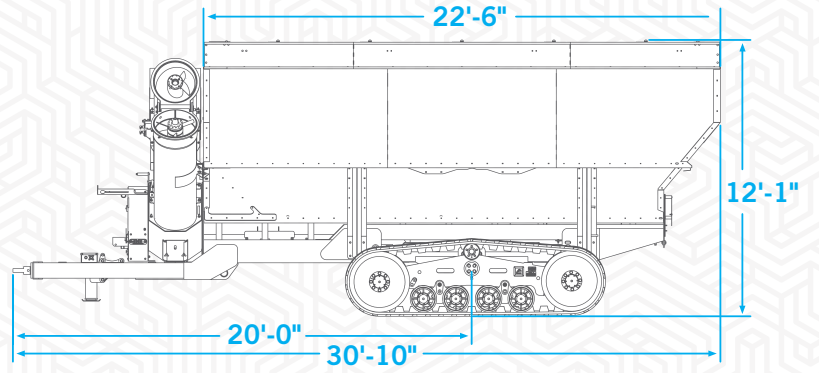
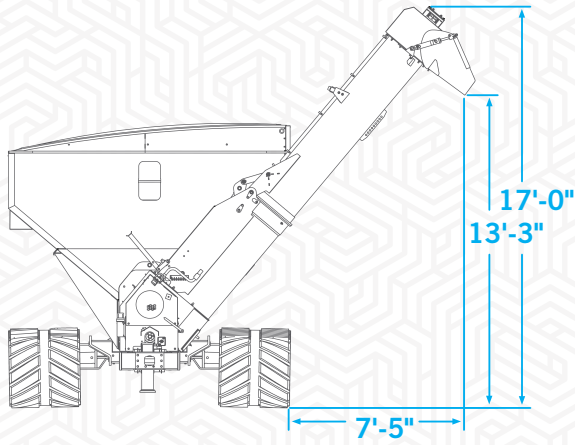

# CORNER SINGLE AUGER 1051

SPECIFICATIONS

Model	1051	
Undercarriage	Tracks	Flotation Tires
<b>Specifications</b>		
Heaped capacity*	1050 bu.	1050 bu.
Unload speed - maximum**	475 bu/min	475 bu/min
Total weight - empty	23,000 lbs.	15,100 lbs.
Hitch weight - empty	2,500 lbs.	2,500 lbs.
Hitch weight - loaded	5,000 lbs.	5,000 lbs.
Width - grain tank	12'-4"	12'-4"
Length - grain tank	19'-4"	19'-4"
Height - short side	11'-9"	11'-9"
Height - high side	12'-9"	12'-9"
Length - overall	30'-7"	30'-7"
PSI capacity***	11 psi	23 psi/ 29 psi diamond float
<b>Tractor Requirements (minimum)</b>		
Tractor horsepower	250 hp	
Tractor hydraulics	3 SCVs; 2,320 system psi	
<b>Features and options</b>		
Vertical auger	STD with 20" diameter flighting with a 21" diameter tube	
Gearbox	STD with 90 degree, 3.5" - 4" pitch cut gears, 2:1 ratio	
PTO	STD with 1-3/4" diameter, 20 spline, 1000 rpm PTO	
Tracks	OPT; 36" x 100" contact area	---
Diamond tread tires	---	OPT; 900/60 R32
Lug tread tires	---	OPT; VF 1050/50 R32
5-point scale package	OPT	OPT
GT400 scale display	OPT	OPT
GT560 Autolog scale display	OPT	OPT
Remote scale readout	OPT	OPT
Roll tarp - manual	STD	STD
Safety chains	STD	STD
Adjustable spout	STD	STD

## Tracks

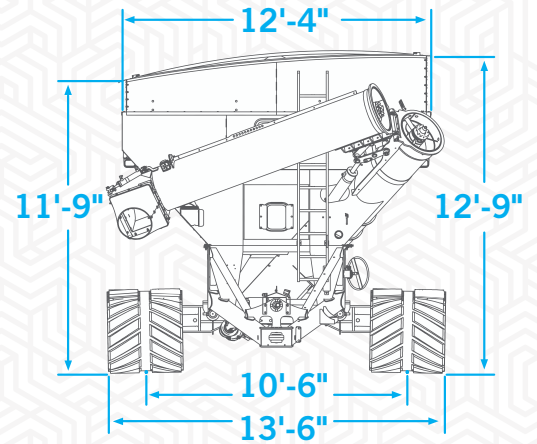

## Flotation Tires

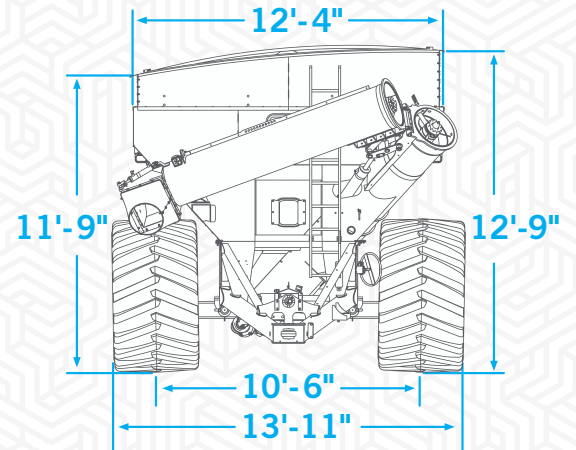

\*Cart capacity and hitch weight are based on #2 corn at 15% moisture (56lb test weight). Cart capacity and hitch weight may vary based on crop type, grade, moisture and other environmental factors.

\*\*Approximate with 15% moisture corn. Bushels/minute will vary with moisture content of grain and/or PTO rpm.

\*\*\*Comparative PSI @ 3" soil penetration depth using 56 lb. test weight grain at 15% moisture at posted capacities.

