

KINZE[®]

GRAIN CARTS



WHY A KINZE

In 1971, Kinze pioneered and introduced the very first dual auger grain cart to help farmers get their crop out during adverse weather. For the 50 years since then Kinze has been constantly innovating the dual auger cart lineup to be the standard of reliability and efficiency. Built for long life and ease of use, Kinze grain carts have a great return on investment because of their dependability, generous capacities, and strong trade-in values. Kinze dual auger grain carts have the only 2-year grain cart warranty in the industry.



- Low driveline maintenance from the auto-reset, torque limiting overrunning clutch



- 50% longer auger wear life from thickened edge auger design
- Kinze dual auger grain carts have the only 2-year warranty in the industry; single auger grain carts are covered by a 1-year warranty



DURABLE

- Easily navigate rolling terrain with the low-profile design
- Exceptional operator line-of-sight visibility and easy control of grain with clean auger designs



RELIABLE

- Proven design with all the features necessary for a successful harvest
- Easy tool-less access to the inspection cover and grain transfer cleanout
- Quick and quiet unloading with the large diameter augers and positive driveline engagement



THE FIRST CARTS ARE STILL RUNNING

To celebrate the 50th anniversary of the Kinze grain cart, we ran a contest not only to find the oldest operating grain cart but to give our customers an opportunity to brag about their trusted Kinze carts. There were some definite surprise discoveries along the way. Here's the story . . .



SCAN ME

CORNER DUAL AUGER

HARVEST COMMANDER

1721

1700 BUSHELS* | 750 BU/MIN**

True reliability. Simple to operate. Easily maintained. When chasing multiple combines in a field, the large-capacity Kinze 1721 Dual Auger grain cart with up to 1,700 bushels of heaped capacity is up to the task. Unmatched line-of-sight visibility from the clean corner auger design, and easy operating features, enable drivers of all experience levels to operate it confidently. An intuitive and ergonomic joystick provides control of auger tilt, spout tip, horizontal auger, and flow gate for efficient operation. When changing crops or moving to a new field, cleanout is swift and easy with horizontal auger cleanout doors. Tracked undercarriage has a low-pressure footprint from dedicated high flotation 36" x 108" of tracks.

*Cart capacity and hitch weight are based on #2 corn at 15% moisture (56lb test weight). Cart capacity and hitch weight may vary based on crop type, grade, moisture and other environmental factors.

**Approximate with 15% moisture corn. Bushels/minute will vary with moisture content of grain and/or PTO rpm.



HARVEST COMMANDER

1521

1500 BUSHELS* (TRACKS) | 1450 BUSHELS* (TIRES) | 750 BU/MIN**

True reliability. Simple to operate. Easily maintained. Complete your harvest with ease, enjoy years of dependable service, and realize an excellent return on investment with the 1521 dual auger grain cart. Unmatched line-of-sight visibility from the clean corner auger design, and easy operating features, enable drivers of all experience levels to operate it confidently. An intuitive and ergonomic joystick provides control of auger tilt, spout tip, horizontal auger, and flow gate for efficient operation. To help ensure an uninterrupted harvest, the driveline and track system have minimum maintenance requirements.

Optional 36" x 100" Camso tracks reduce soil compaction and enable easy transfer of grain from field to truck in adverse conditions.



HARVEST COMMANDER

1421

1400 BUSHELS* (TRACKS) | 1350 BUSHELS* (TIRES) | 750 BU/MIN**

Do you need more clearance between the combine spout and the cart? The 1421 dual auger grain cart has the same great features as our other dual auger carts, but with 6" lower sidewalls. With up to 1,400 bushels of heaped capacity, it efficiently gets crop out of the field. Unmatched line-of-sight visibility from the clean corner auger design, and easy operating features, enable drivers of all experience levels to operate it confidently. An intuitive and ergonomic joystick provides control of auger tilt, spout tip, horizontal auger, and flow gate for efficient operation. To help ensure an uninterrupted harvest, the driveline and track system have minimum maintenance requirements.

Optional 36" x 100" Camso tracks reduce soil compaction and enable easy transfer of grain from field to truck in adverse conditions.



HARVEST COMMANDER

1321

1300 BUSHELS (TRACKS) | 1250 BUSHELS (TIRES) | 750 BU/MIN*

When it's time to harvest, you need a grain cart that you can rely on. With up to 1300 bushels heaped capacity, the 1321 dual auger grain cart will increase harvest efficiency while being durable and easy to use. Unmatched line-of-sight visibility from the clean corner auger design, and easy operating features, enable drivers of all experience levels to operate it confidently. An intuitive and ergonomic joystick provides control of auger tilt, spout tip, horizontal auger, and flow gate for efficient operation. To help ensure an uninterrupted harvest, the driveline and track system have minimum maintenance requirements.

Optional 36" x 100" Camso tracks reduce soil compaction and enable easy transfer of grain from field to truck in adverse conditions.



CORNER DUAL AUGER

OPTIMUM CAPACITIES



1321
1300-bushel capacity



1421
1400-bushel capacity



Central Grease Bank

A centralized grease bank enables swift and easy lubrication of all grease points

Auger Cleanout

Horizontal auger cleanout doors for easy crop changeover

Tool-less Access

Oversized wing fasteners allow tool-less access to the inspection cover and grain transfer cleanout

Hose Cradle

Hydraulic hose cradle and colored hose handles for easy hook-up and storage



Tip Spout

The joystick-controlled aligned tip spout delivers smooth grain flow and precision unloading of grain

Rolling Tarp

Standard equipped, manually operated rolling tarp protects harvest from the weather; electrically operated rolling tarp is optional

Remote Scale Readout

Optional remote scale readout for viewing by combine operator now connects to the serial port on the scale head

Joystick Control

Easily control the spout tip, horizontal auger on/off, flow gate, and auger tilt with the intuitive joystick controller



1521
1500-bushel capacity



1721
1700-bushel capacity



TRANSPORT OPTIONS

1721 Tracks

- The 1721 grain cart comes with dedicated 36" x 108" tracks

Camso Tracks

- Camso tracks are available on 1321, 1421, and 1521 model grain carts
- The 36" x 100" footprint provides low soil pressure in adverse conditions
- Equipped with self-tensioning belts, pivoting bogie wheels, and oil bath hubs

Flotation Tire

- Available on 1321, 1421, and 1521 model grain carts
- The high flotation 1250/50R32 tires deliver low ground pressure
- Lug design provides great mud-handling performance

FEATURES & OPTIONS

Hydraulically adjustable flow gate

24" vertical and 22" horizontal augers

Torque limiting driveline clutch

Tracks or flotation tires

Electronic 5-point scale options

Remote scale readout

Pivoting external corner auger

Joystick auger control

Horizontal auger cleanout doors

Smooth flow aligned tip spout

Centralized grease bank

Hydraulic hose cradle and colored ends

2-year warranty

DUAL AUGER

HARVEST COMMANDER

1121

HARVEST COMMANDER 1121 DUAL AUGER GRAIN CART 1100 BUSHELS* | 550 BU/MIN**

Based on the proven and legendary 1050 dual auger grain cart, the 1121 is establishing its own place as a legend. The 1121 is available with dual 480/80 R42 row crop tires – ideally suited for easy truck transport from farm to farm.

The proven, straightforward dual auger design of the 1121 provides the key features necessary for efficient grain handling. The on-demand horizontal auger, optimum 1100-bushel capacity, tip spout control, and multiple undercarriage options deliver high value at a low cost of ownership. Robust construction, along with minimum driveline and track system maintenance, ensures an uninterrupted and productive harvest.

*Cart capacity and hitch weight are based on #2 corn at 15% moisture (56lb test weight). Cart capacity and hitch weight may vary based on crop type, grade, moisture and other environmental factors.

**Approximate with 15% moisture corn. Bushels/minute will vary with moisture content of grain and/or PTO rpm.



FEATURES & OPTIONS

20" vertical and horizontal augers

Torque limiting driveline clutch

Camso tracks

Flotation tires

Row crop tires

Electronic 3-point scale options

Remote scale readout

Centralized grease bank

Vertical auger tip spout

Horizontal auger cleanout doors

Hydraulic hose cradle and colored ends

2-year warranty

DUAL AUGER

1121

Remote Scale Readout

Optional remote scale readout for viewing by combine operator now connects to the serial port on the scale head

Tip Spout

Simple tip spout grain control using tractor SCV

Central Grease Bank

A centralized grease bank enables swift and easy lubrication of all grease points



Rolling Tarp

Standard equipped, manually operated rolling tarp protects harvest from the weather

Optimum Capacity

Efficient 1100-bushel capacity; secure load containment with high and low backboards



LED Lighting

Rear, spout, and hopper LED lighting for greater visibility

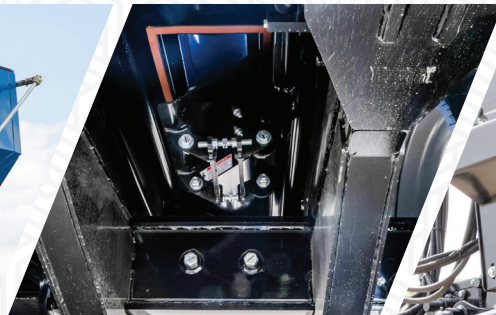

Auger Cleanout

Horizontal auger cleanout doors for easy crop changeover

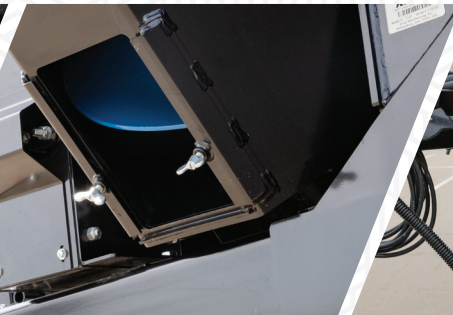

Tool-less Access

Oversized wing fasteners allow tool-less access to the inspection cover and grain transfer cleanout



Hose Cradle

Hydraulic hose cradle and colored hose handles for easy hook-up and storage



TRANSPORT OPTIONS

Camso Tracks

- The 36" x 100" footprint provides low soil pressure in adverse conditions
- Equipped with self-tensioning belts, pivoting bogie wheels, and oil bath hubs



Flotation Tires

- The high flotation 1245/50R32 tires deliver low ground pressure
- Lug design provides great mud-handling performance



Row Crop Tires

- Dual row crop 480/80 R42 tires for easy truck transport
- Swing axle design enables easy access and maintenance of the dual tires
- Central grease bank for quick lubrication of all row crop tire grease points

CORNER SINGLE AUGER

HARVEST COMMANDER

1051

1050 BUSHELS* | 475 BU/MIN**

Harvest demands dependable grain handling equipment. Just like Kinze's dual auger carts, the 1051 single auger grain cart is built with robust materials and components to make it tough, durable, and reliable, but at a lower cost of ownership. With unmatched line-of-sight visibility from the clean corner auger design, and easy operating features, drivers at all experience levels can operate it confidently. Equipped with a quiet operating driveline free of sheer bolts, uptime is significantly improved for a more efficient harvest. The easy to operate pit dump door makes pit unloading quick and effortless, and makes fast work of complete cleanout for crop changeover.

Optional Camso tracks reduce soil compaction and enable easy transfer of grain from field to truck in adverse conditions.

*Cart capacity and hitch weight are based on #2 corn at 15% moisture (56lb test weight). Cart capacity and hitch weight may vary based on crop type, grade, moisture and other environmental factors.

**Approximate with 15% moisture corn. Bushels/minute will vary with moisture content of grain and/or PTO rpm.



FEATURES & OPTIONS

35-degree adjustable spout

Hydraulically adjustable flow gate

20" front fold corner auger

Pit dump door

Torque limiting driveline clutch

Camso tracks or flotation tires

Electronic scale options

Remote scale readout

1-year warranty on single auger cart



Tip Spout

Delivers smooth grain flow and precision unloading of grain



Pit Dump Unloading

Fast pit unloading, and quick and easy cleanout with standard pit dump door



Auger Visibility

Front folding corner auger for excellent visibility



Simple Hookup

Hydraulic hose cradle and colored hose handles for easy hookup and storage



TRANSPORT OPTIONS

Camso Tracks

- The 36" x 100" footprint provides low soil pressure in adverse conditions
- Equipped with self-tensioning belts, pivoting bogie wheels, and oil bath hubs



Flotation Tires

- The high flotation 1050/50R32 tires deliver low ground pressure
- Lug design provides great mud-handling performance
- Radial diamond tread flotation is also available

CORNER DUAL AUGER 1721 1521

SPECIFICATIONS

Model	1721	1521	
Undercarriage	Tracks	Tracks	Flotation Tires
Specifications			
Heaped capacity*	1700 bu.	1500 bu.	1450 bu.
Unload speed - maximum**	750 bu/min	750 bu/min	750 bu/min
Total weight - empty	35,180 lbs.	31,680 lbs.	25,400 lbs.
Hitch weight - empty	5,250 lbs.	4,040 lbs.	4,040 lbs.
Hitch weight - loaded	7,380 lbs.	6,600 lbs.	6,600 lbs.
Width - overall	13'-0"	13'-0"	13'-10"
Length - overall	39'-3"	39'-3"	35'-4"
Height - overall	12'-5"	12'-5"	12'-3"
PSI capacity***	17 psi	16 psi	24 psi
Tractor Requirements (minimum)			
Tractor horsepower	450 hp	370 hp	
Tractor hydraulics	2 SCVs; 2,320 system psi	2 SCVs; 2,320 system psi	
Features and options			
Vertical auger	STD with 22" diameter flighting with a 24" diameter tube		
Horizontal auger	STD with 20" diameter flighting with a 22" diameter tube		
Gearbox	STD with bevel and spur gears, 2:1 ratio		
Drive belts	STD with two 4-band, multi-strand V-belts		
Drive sheaves	STD with 8-groove 8" diameter drive and 16" diameter driven sheaves		
PTO	STD with 1-3/4" diameter, 20 spline, 1000 rpm PTO		
Joystick control	STD ; controls four cart functions: spout tip, horizontal auger on/off, flow gate, and auger tilt		
Tracks	STD; 36" x 108" contact area	OPT; 36" x 100" contact	---
Flotation tires	N/A	---	OPT; IF1250/50R32 CFO (R1)
5-point scale package	STD	STD	
GT400 scale display	OPT	OPT	
GT560 Autolog scale display	OPT	OPT	
Remote scale readout	OPT	OPT	
Roll tarp - manual	STD	STD	
Roll tarp - electric	OPT	OPT	
Safety chains	STD	STD	
Adjustable spout	STD	STD	

*Cart capacity and hitch weight are based on #2 corn at 15% moisture (56lb test weight). Cart capacity and hitch weight may vary based on crop type, grade, moisture and other environmental factors.

**Approximate with 15% moisture corn. Bushels/minute will vary with moisture content of grain and/or PTO rpm.

***Comparative PSI @ 3" soil penetration depth using 56 lb. test weight grain at 15% moisture at posted capacities.

Tracks

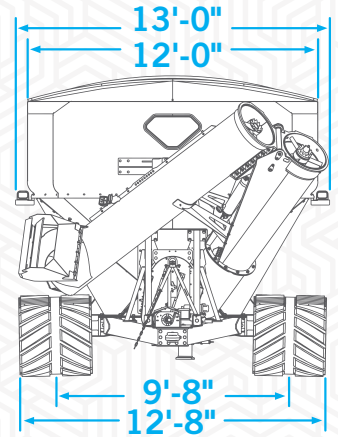

Flotation Tires

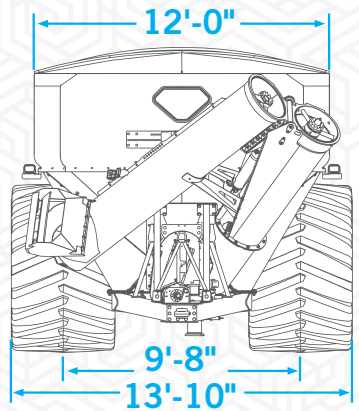

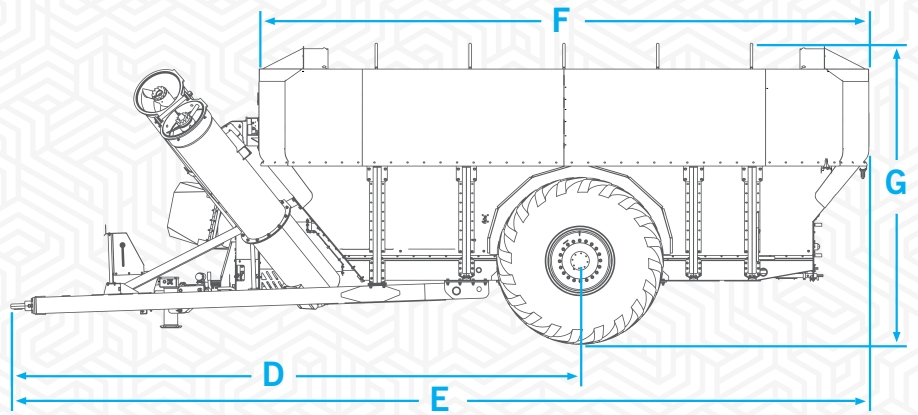
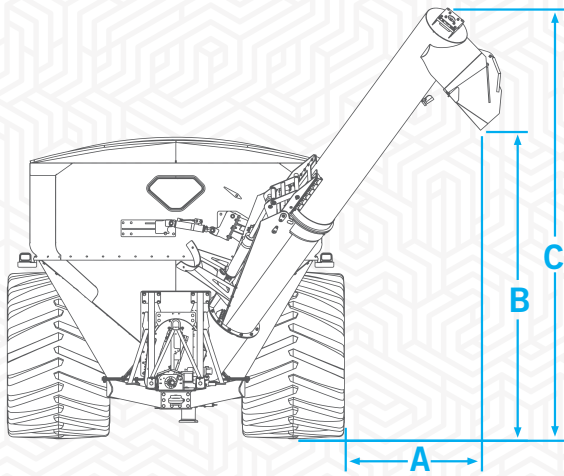
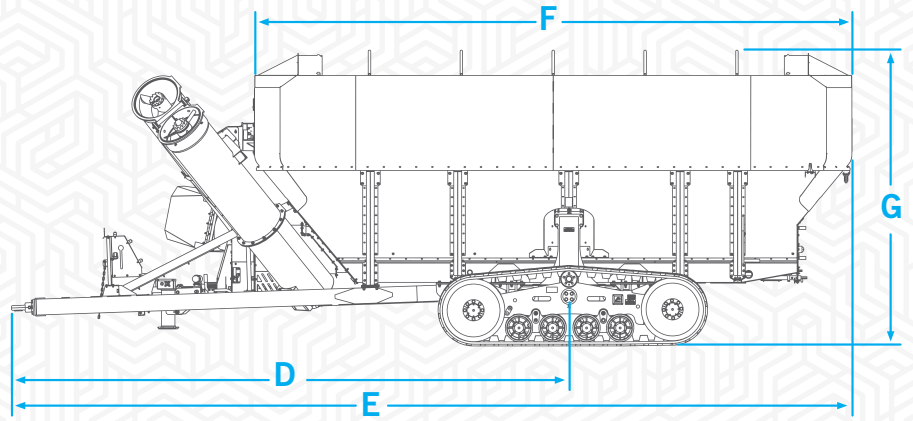
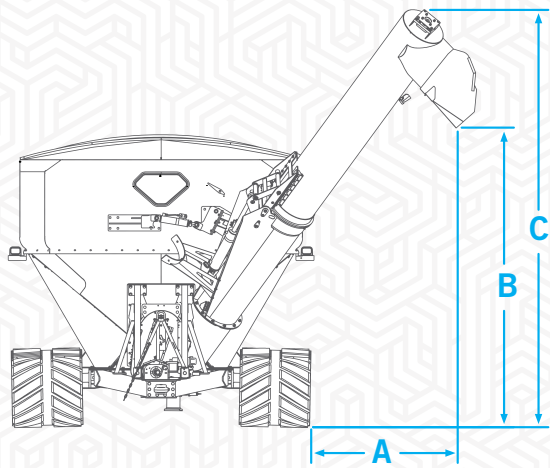

DIMENSION	1721		1521
	Tracks	Tracks	Floats
A—Auger and spout rotated down	6'-11"	6'-11"	7'-5"
A—Auger and spout rotated up	6'-9"	6'-9"	7'-1"
B—Auger and spout rotated down	10'-2"	10'-2"	10'-0"
B—Auger and spout rotated up	13'-5"	13'-5"	13'-4"
C—Auger rotated down	15'-8"	15'-8"	15'-6"
C—Auger rotated up	17'-9"	17'-9"	17'-7"
D	25'-4"	25'-4"	23'-6"
E	39'-3"	39'-3"	35'-4"
F	29'-0"	29'-0"	25'-1"
G	12'-5"	12'-5"	12'-3"



CORNER DUAL AUGER 1421 1321

SPECIFICATIONS

Model	1421		1321	
Undercarriage	Tracks	Flotation Tires	Tracks	Flotation Tires
Specifications				
Heaped capacity*	1400 bu.	1350 bu.	1300 bu.	1250 bu.
Unload speed - maximum**	750 bu/min	750 bu/min	750 bu/min	750 bu/min
Total weight - empty	31,470 lbs.	25,190 lbs.	31,000 lbs.	24,900 lbs.
Hitch weight - empty	4,000 lbs.	4,000 lbs.	3,950 lbs.	3,950 lbs.
Hitch weight - loaded	6,540 lbs.	6,540 lbs.	6,280 lbs.	6,280 lbs.
Width - overall	13'-0"	13'-10"	13'-0"	13'-10"
Length - overall	35'-4"	35'-4"	32'-0"	32'-0"
Height - overall	11'-11"	11'-9"	12'-5"	12'-3"
PSI capacity***	15 psi	23 psi	14 psi	22 psi
Tractor Requirements (minimum)				
Tractor horsepower	350 hp		300 hp	
Tractor hydraulics	2 SCVs; 2,320 system psi		2 SCVs; 2,320 system psi	
Features and options				
Vertical auger	STD with 22" diameter flighting with a 24" diameter tube			
Horizontal auger	STD with 20" diameter flighting with a 22" diameter tube			
Gearbox	STD with bevel and spur gears, 2:1 ratio			
Drive belts	STD with two 4-band, multi-strand V-belts			
Drive sheaves	STD with 8-groove 8" diameter drive and 16" diameter driven sheaves			
PTO	STD with 1-3/4" diameter, 20 spline, 1000 rpm PTO			
Joystick control	STD ; controls four cart functions: spout tip, horizontal auger on/off, flow gate, and auger tilt			
Tracks	OPT; 36" x 100" contact	---	OPT; 36" x 100" contact	---
Flotation tires	---	OPT; IF1250/50R32 CFO (R1)	---	OPT; IF1250/50R32 CFO (R1)
5-point scale package	STD		STD	
GT400 scale display	OPT		OPT	
GT560 Autolog scale display	OPT		OPT	
Remote scale readout	OPT		OPT	
Roll tarp - manual	STD		STD	
Roll tarp - electric	OPT		OPT	
Safety chains	STD		STD	
Adjustable spout	STD		STD	

*Cart capacity and hitch weight are based on #2 corn at 15% moisture (56lb test weight). Cart capacity and hitch weight may vary based on crop type, grade, moisture and other environmental factors.

**Approximate with 15% moisture corn. Bushels/minute will vary with moisture content of grain and/or PTO rpm.

***Comparative PSI @ 3" soil penetration depth using 56 lb. test weight grain at 15% moisture at posted capacities.

Tracks

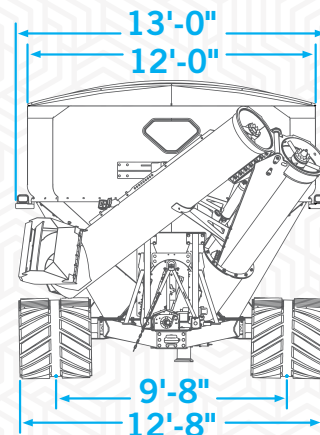

Flotation Tires

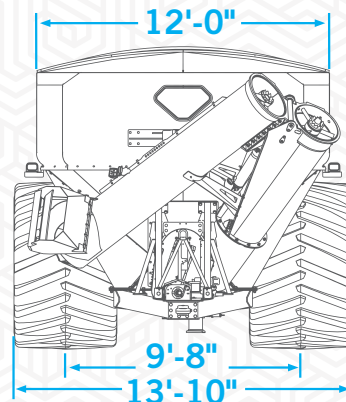

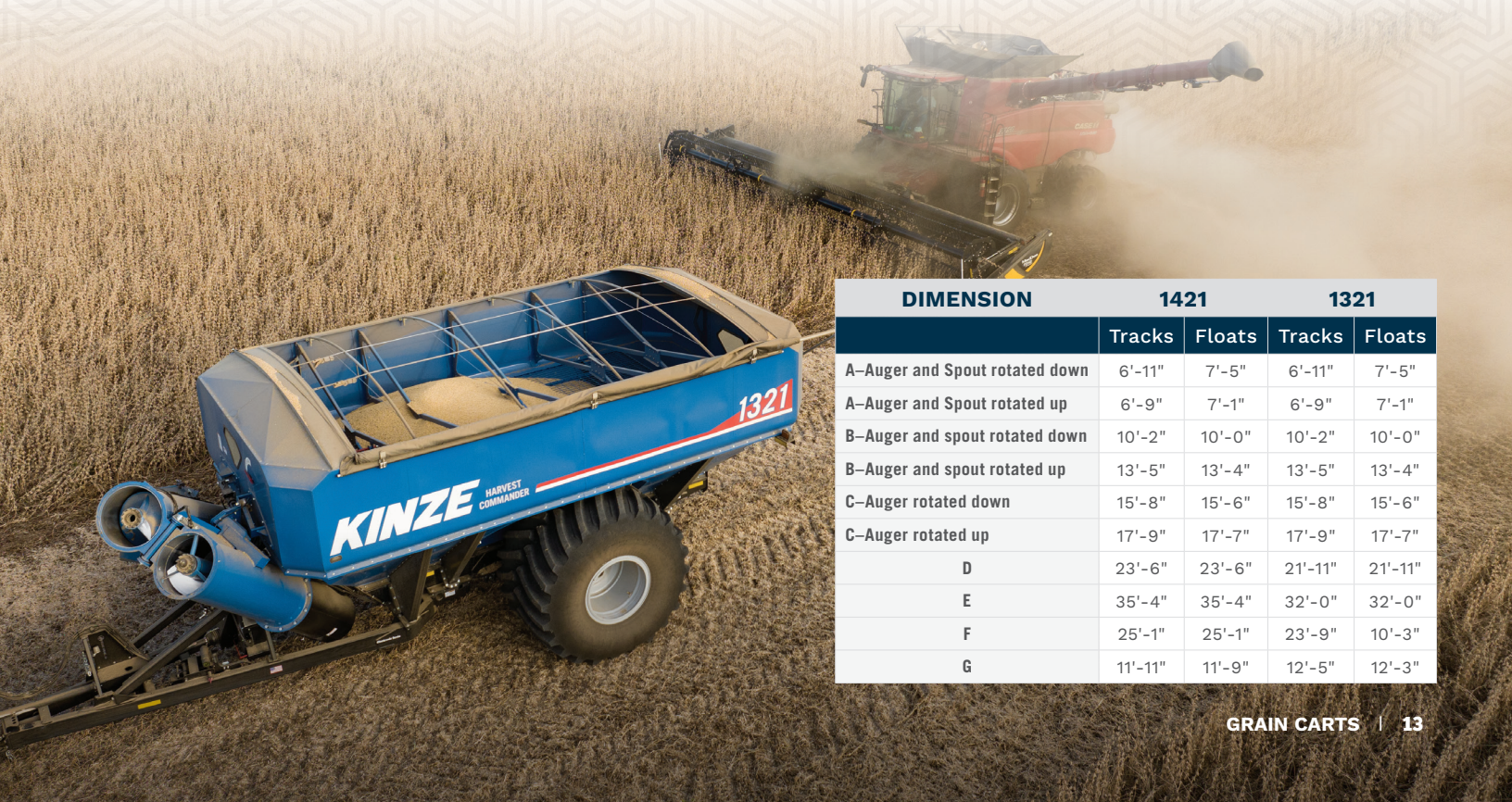
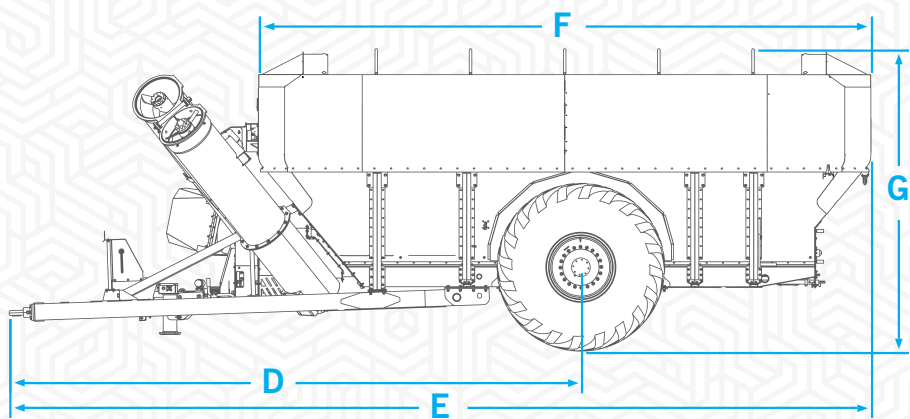
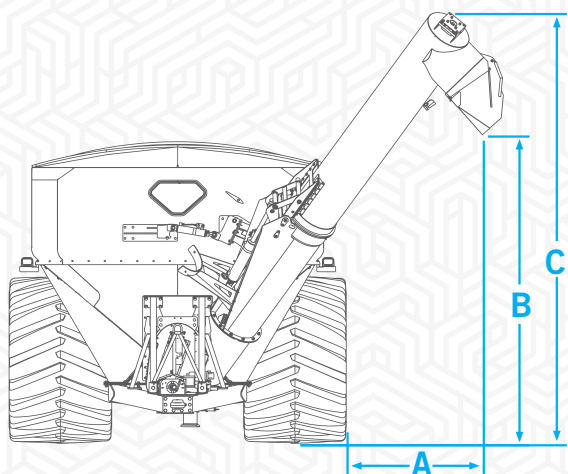
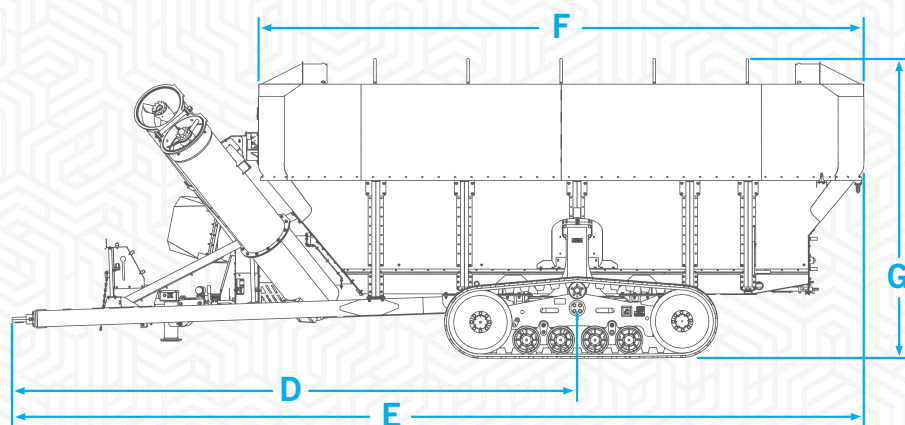
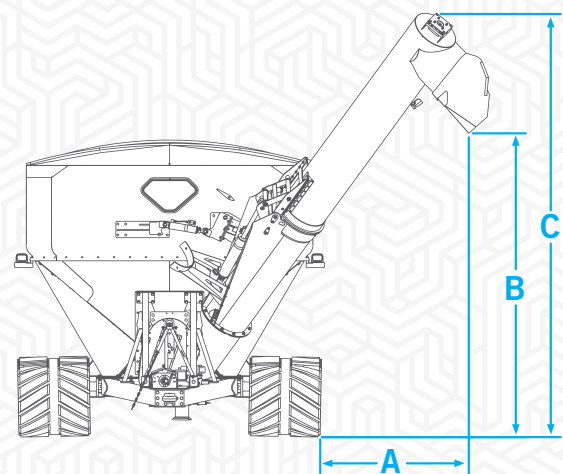

DIMENSION	1421		1321	
	Tracks	Floats	Tracks	Floats
A—Auger and Spout rotated down	6'-11"	7'-5"	6'-11"	7'-5"
A—Auger and Spout rotated up	6'-9"	7'-1"	6'-9"	7'-1"
B—Auger and spout rotated down	10'-2"	10'-0"	10'-2"	10'-0"
B—Auger and spout rotated up	13'-5"	13'-4"	13'-5"	13'-4"
C—Auger rotated down	15'-8"	15'-6"	15'-8"	15'-6"
C—Auger rotated up	17'-9"	17'-7"	17'-9"	17'-7"
D	23'-6"	23'-6"	21'-11"	21'-11"
E	35'-4"	35'-4"	32'-0"	32'-0"
F	25'-1"	25'-1"	23'-9"	10'-3"
G	11'-11"	11'-9"	12'-5"	12'-3"

Model	1121		
Undercarriage	Tracks	Flotation Tires	Row Crop Tires
Specifications			
Heaped capacity*	1125 bu.	1100 bu.	1100 bu.
Unload speed - maximum**	550 bu/min	550 bu/min	550 bu/min
Total weight - empty	26,620 lbs.	20,880 lbs.	21,440 lbs.
Hitch weight - empty	3,820 lbs.	3,820 lbs.	3,820 lbs.
Hitch weight - loaded	6,260 lbs.	6,260 lbs.	6,260 lbs.
Width - overall	12'-0"	12'-1"	12'-0"
Length - overall	30'-10"	30'-10"	30'-10"
Height - short side	10'-11"	11'-0"	11'-0"
Height - high side	12'-0"	12'-1"	12'-1"
PSI capacity***	12 psi	23 psi	25 psi
Tractor Requirements (minimum)			
Tractor horsepower	250 hp	250 hp	250 hp
Tractor hydraulics	3 SCVs; 2,320 system psi		
Features and options			
Vertical auger	STD with 20" diameter flighting with a 22" diameter tube		
Horizontal auger	STD with 20" diameter flighting with a 22" diameter tube		
Gearbox	STD with 90 degree, 3.5" - 4" pitch cut gears, 2:1 ratio		
Drive belts	STD with two 4-band, multi-strand V-belts		
Drive sheaves	STD with 8-groove 7-1/2" diameter drive and 15" diameter driven sheaves		
PTO	STD with 1-3/4" diameter, 20 spline, 1000 rpm PTO		
Tracks	OPT; 36" x 100" contact area	---	---
Flotation tires	---	OPT; 1245/50R32	---
Row crop tires	---	---	OPT; 480/80 R42
3-point scale package	STD	STD	STD
GT400 scale display	OPT	OPT	OPT
GT560 Autolog scale display	OPT	OPT	OPT
Remote scale readout	OPT	OPT	OPT
Roll tarp - manual	STD	STD	STD
Safety chains	STD	STD	STD
Adjustable spout	STD	STD	STD

*Cart capacity and hitch weight are based on #2 corn at 15% moisture (56lb test weight). Cart capacity and hitch weight may vary based on crop type, grade, moisture and other environmental factors.

**Approximate with 15% moisture corn. Bushels/minute will vary with moisture content of grain and/or PTO rpm.

***Comparative PSI @ 3" soil penetration depth using 56 lb. test weight grain at 15% moisture at posted capacities.

Tracks

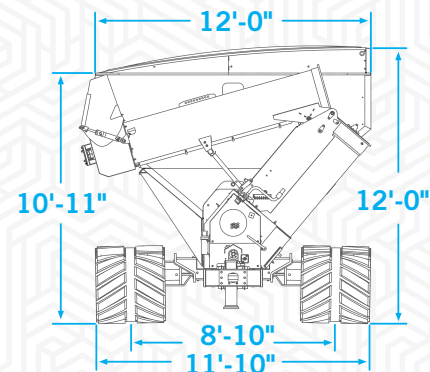

Flotation Tires

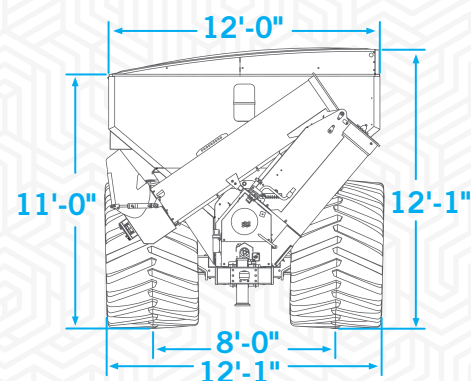

Row Crop Tires

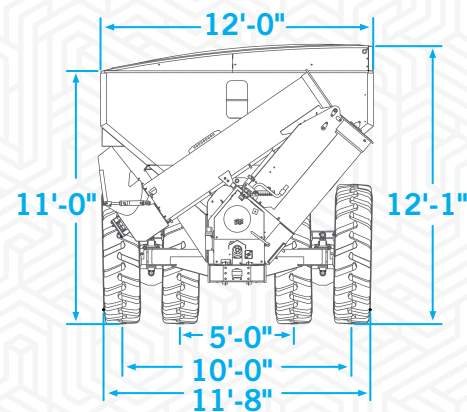

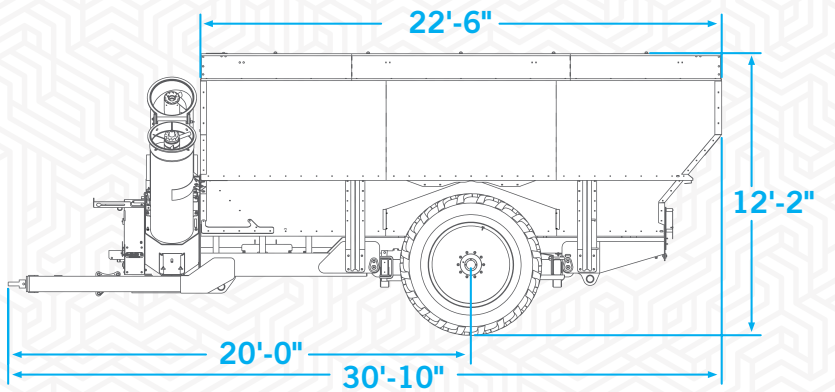
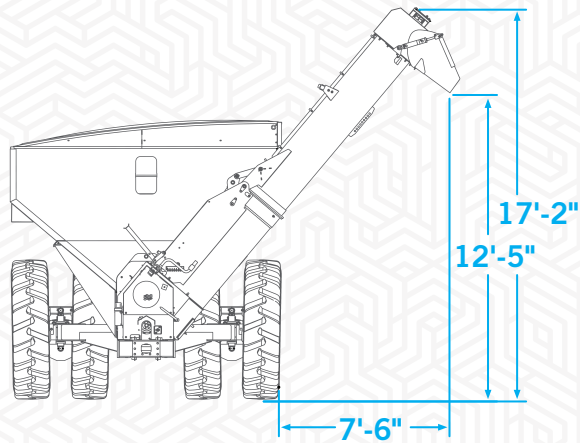
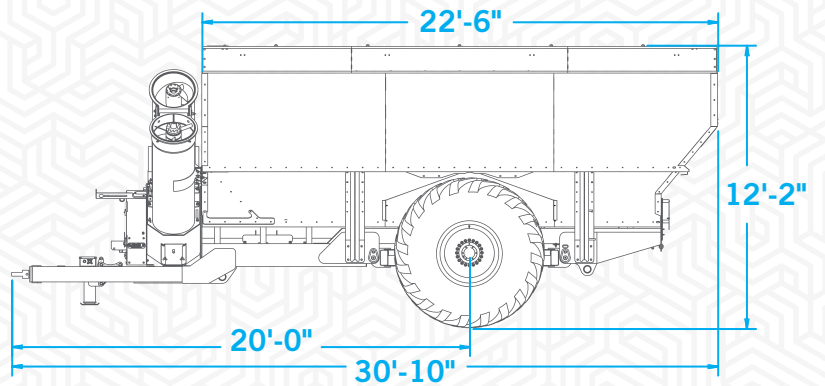
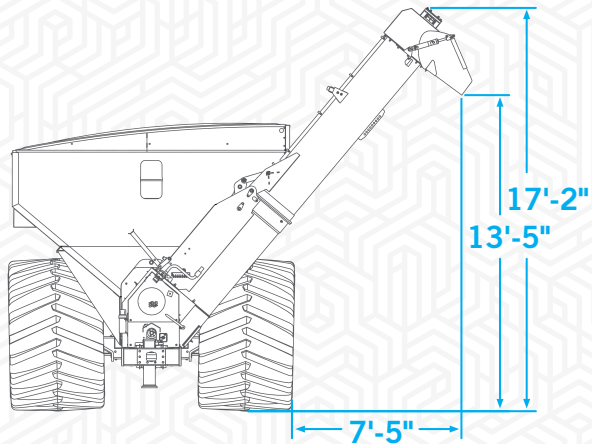
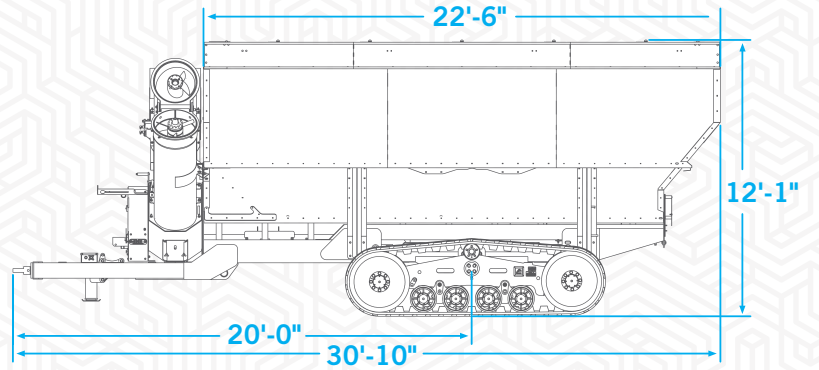
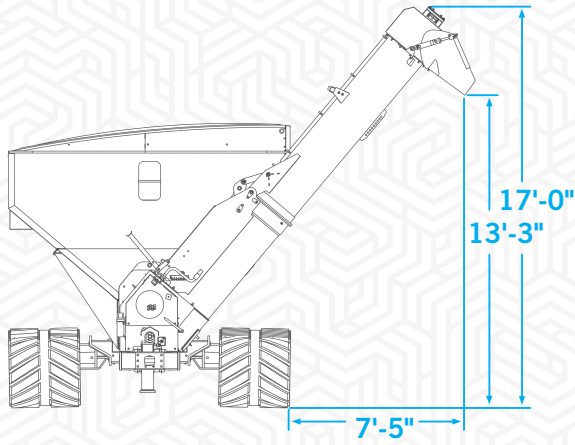

CORNER SINGLE AUGER 1051

SPECIFICATIONS

Model	1051	
Undercarriage	Tracks	Flotation Tires
Specifications		
Heaped capacity*	1050 bu.	1050 bu.
Unload speed - maximum**	475 bu/min	475 bu/min
Total weight - empty	23,000 lbs.	15,100 lbs.
Hitch weight - empty	2,500 lbs.	2,500 lbs.
Hitch weight - loaded	5,000 lbs.	5,000 lbs.
Width - grain tank	12'-4"	12'-4"
Length - grain tank	19'-4"	19'-4"
Height - short side	11'-9"	11'-9"
Height - high side	12'-9"	12'-9"
Length - overall	30'-7"	30'-7"
PSI capacity***	11 psi	23 psi/ 29 psi diamond float
Tractor Requirements (minimum)		
Tractor horsepower	250 hp	
Tractor hydraulics	3 SCVs; 2,320 system psi	
Features and options		
Vertical auger	STD with 20" diameter flighting with a 21" diameter tube	
Gearbox	STD with 90 degree, 3.5" - 4" pitch cut gears, 2:1 ratio	
PTO	STD with 1-3/4" diameter, 20 spline, 1000 rpm PTO	
Tracks	OPT; 36" x 100" contact area	---
Diamond tread tires	---	OPT; 900/60 R32
Lug tread tires	---	OPT; VF 1050/50 R32
5-point scale package	OPT	OPT
GT400 scale display	OPT	OPT
GT560 Autolog scale display	OPT	OPT
Remote scale readout	OPT	OPT
Roll tarp - manual	STD	STD
Safety chains	STD	STD
Adjustable spout	STD	STD

Tracks

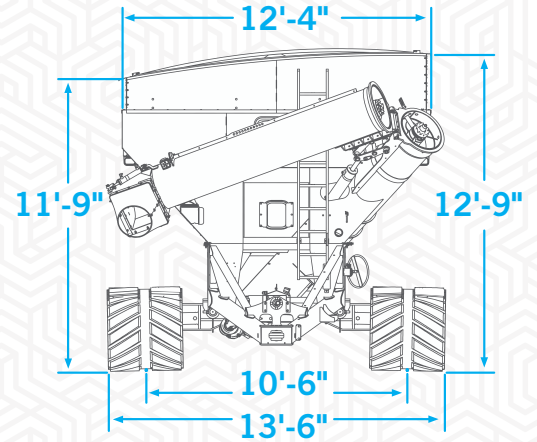

Flotation Tires

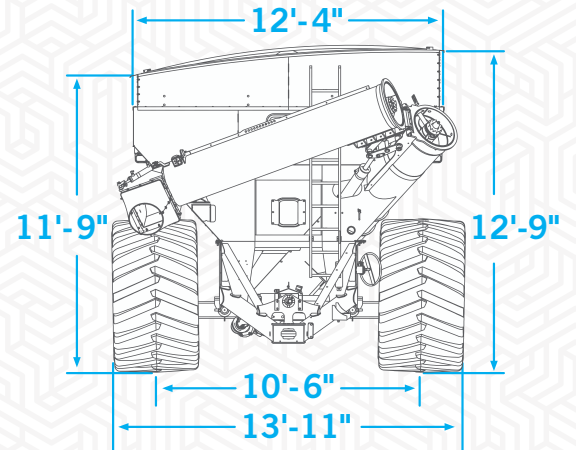

*Cart capacity and hitch weight are based on #2 corn at 15% moisture (56lb test weight). Cart capacity and hitch weight may vary based on crop type, grade, moisture and other environmental factors.

**Approximate with 15% moisture corn. Bushels/minute will vary with moisture content of grain and/or PTO rpm.

***Comparative PSI @ 3" soil penetration depth using 56 lb. test weight grain at 15% moisture at posted capacities.

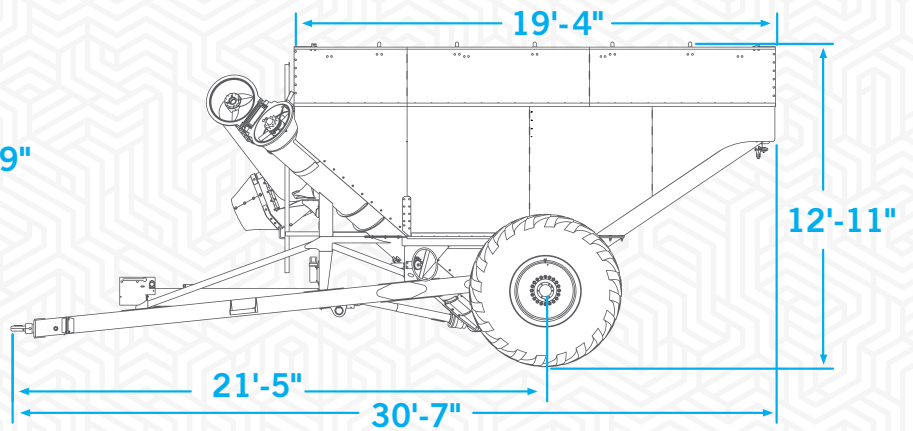
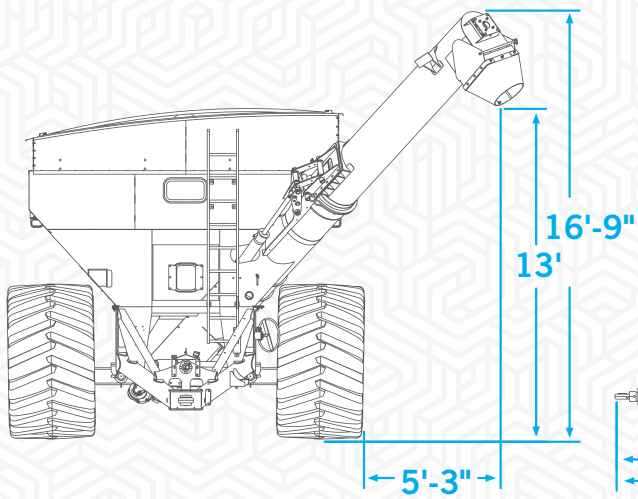
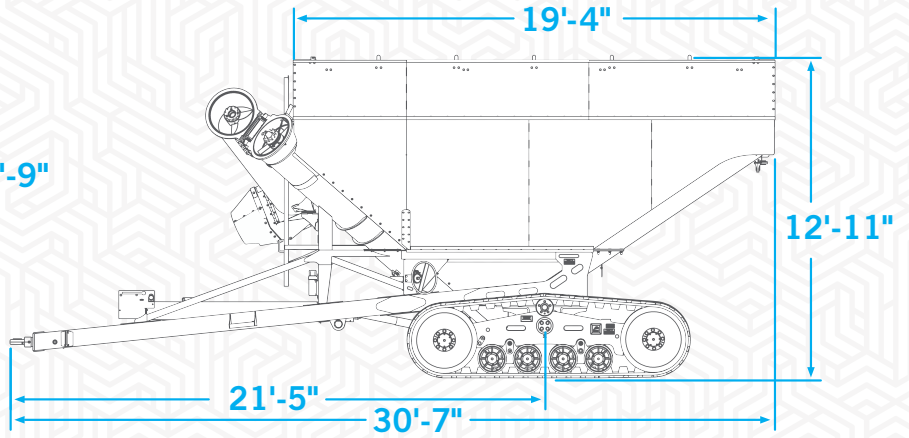
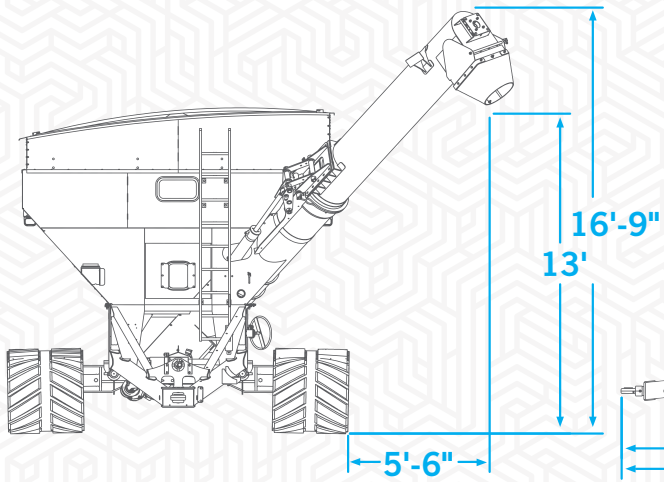



KINZE[®]

Kinze Manufacturing, Inc. • I-80 at Exit 216
Williamsburg, Iowa 52361-0806 USA • visit kinze.com



Authorized Dealer:

© 2024 by Kinze Manufacturing, Inc. Kinze[®], the Kinze[®] logo, are trademarks owned by Kinze Manufacturing, Inc. Kinze Manufacturing, Inc. reserves the right to make changes in engineering, design and specifications, or add improvements at any time without notice or obligation.

MY2024 / GLITGC24MPP
02.2024 / WEB