

| Model | 1121 | | |
|---------------------------------------|---|-----------------|-----------------|
| Undercarriage | Tracks | Flotation Tires | Row Crop Tires |
| Specifications | | | |
| Heaped capacity* | 1125 bu. | 1100 bu. | 1100 bu. |
| Unload speed - maximum** | 550 bu/min | 550 bu/min | 550 bu/min |
| Total weight - empty | 26,620 lbs. | 20,880 lbs. | 21,440 lbs. |
| Hitch weight - empty | 3,820 lbs. | 3,820 lbs. | 3,820 lbs. |
| Hitch weight - loaded | 6,260 lbs. | 6,260 lbs. | 6,260 lbs. |
| Width - overall | 12'-0" | 12'-1" | 12'-0" |
| Length - overall | 30'-10" | 30'-10" | 30'-10" |
| Height - short side | 10'-11" | 11'-0" | 11'-0" |
| Height - high side | 12'-0" | 12'-1" | 12'-1" |
| PSI capacity*** | 12 psi | 23 psi | 25 psi |
| Tractor Requirements (minimum) | | | |
| Tractor horsepower | 250 hp | 250 hp | 250 hp |
| Tractor hydraulics | 3 SCVs; 2,320 system psi | | |
| Features and options | | | |
| Vertical auger | STD with 20" diameter flighting with a 22" diameter tube | | |
| Horizontal auger | STD with 20" diameter flighting with a 22" diameter tube | | |
| Gearbox | STD with 90 degree, 3.5" - 4" pitch cut gears, 2:1 ratio | | |
| Drive belts | STD with two 4-band, multi-strand V-belts | | |
| Drive sheaves | STD with 8-groove 7-1/2" diameter drive and 15" diameter driven sheaves | | |
| PTO | STD with 1-3/4" diameter, 20 spline, 1000 rpm PTO | | |
| Tracks | OPT; 36" x 100" contact area | --- | --- |
| Flotation tires | --- | OPT; 1245/50R32 | --- |
| Row crop tires | --- | --- | OPT; 480/80 R42 |
| 3-point scale package | STD | STD | STD |
| GT400 scale display | OPT | OPT | OPT |
| GT560 Autolog scale display | OPT | OPT | OPT |
| Remote scale readout | OPT | OPT | OPT |
| Roll tarp - manual | STD | STD | STD |
| Safety chains | STD | STD | STD |
| Adjustable spout | STD | STD | STD |

*Cart capacity and hitch weight are based on #2 corn at 15% moisture (56lb test weight). Cart capacity and hitch weight may vary based on crop type, grade, moisture and other environmental factors.

**Approximate with 15% moisture corn. Bushels/minute will vary with moisture content of grain and/or PTO rpm.

***Comparative PSI @ 3" soil penetration depth using 56 lb. test weight grain at 15% moisture at posted capacities.

Tracks

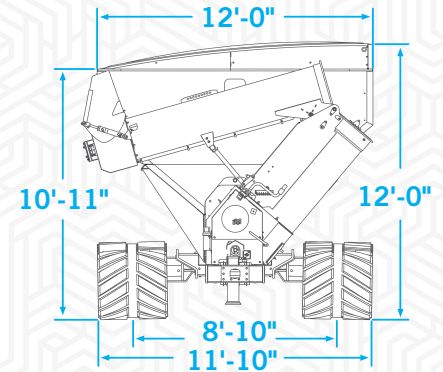

Flotation Tires

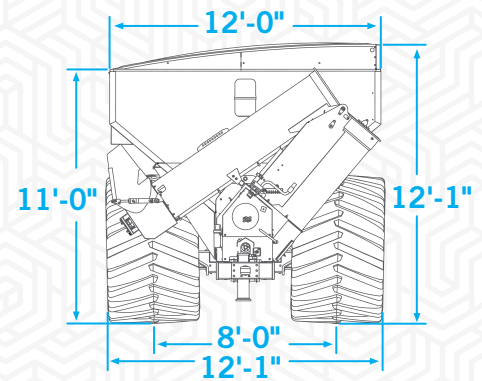

Row Crop Tires

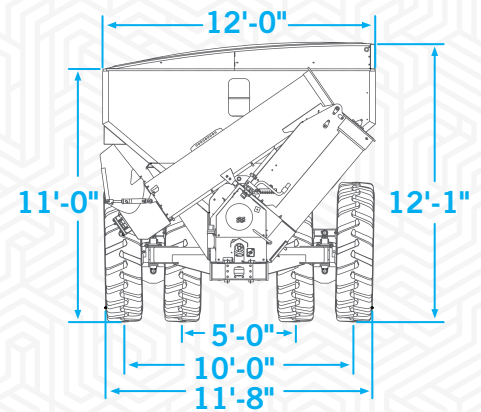

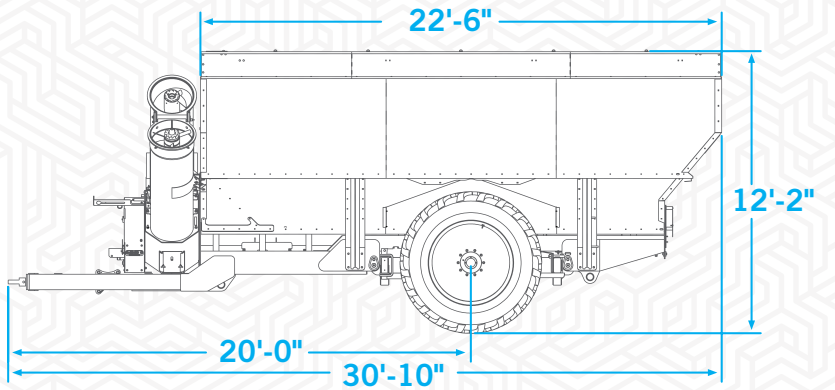
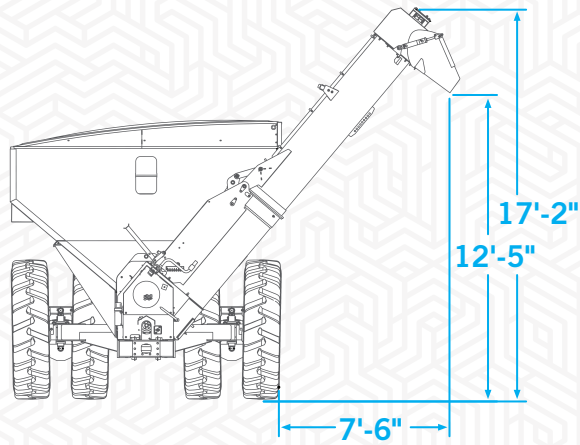
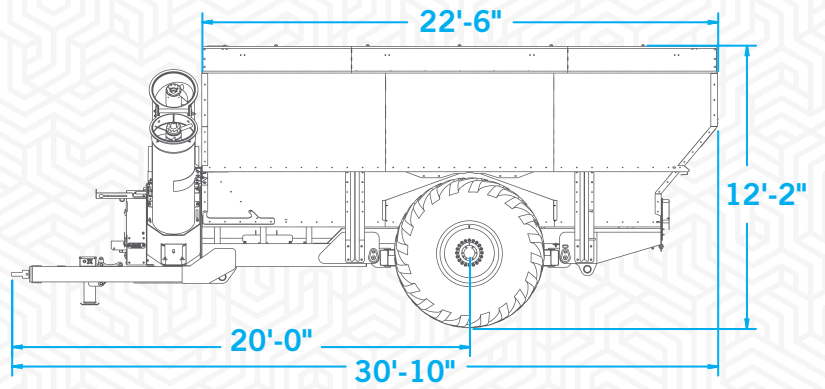
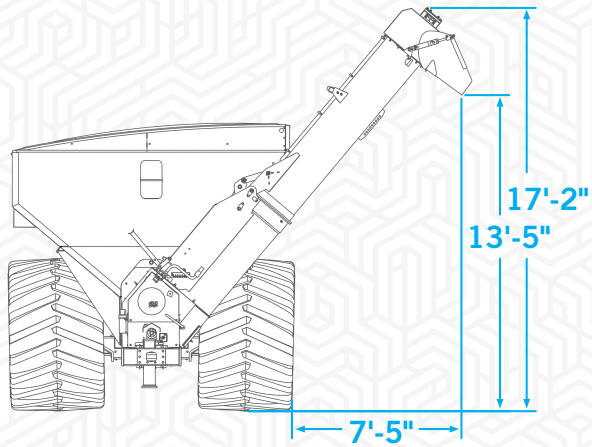
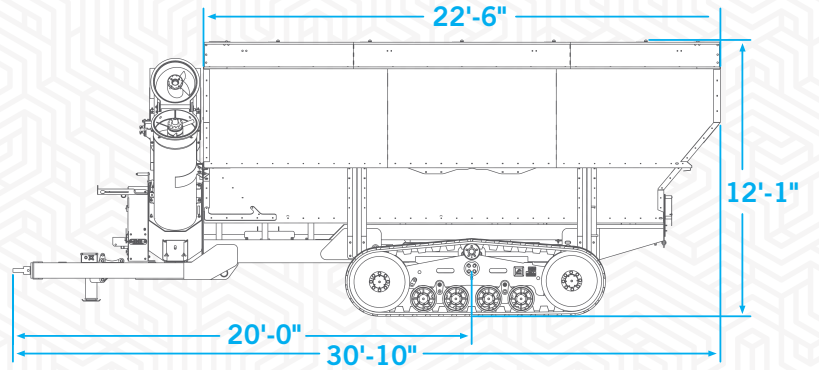
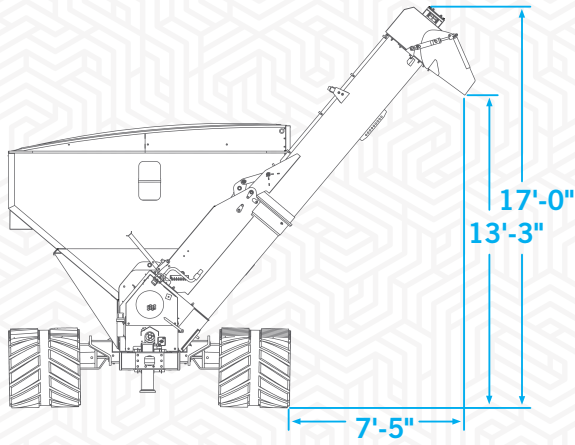

CORNER SINGLE AUGER 1051

SPECIFICATIONS

| Model | 1051 | |
|---------------------------------------|--|------------------------------|
| Undercarriage | Tracks | Flotation Tires |
| Specifications | | |
| Heaped capacity* | 1050 bu. | 1050 bu. |
| Unload speed - maximum** | 475 bu/min | 475 bu/min |
| Total weight - empty | 23,000 lbs. | 15,100 lbs. |
| Hitch weight - empty | 2,500 lbs. | 2,500 lbs. |
| Hitch weight - loaded | 5,000 lbs. | 5,000 lbs. |
| Width - grain tank | 12'-4" | 12'-4" |
| Length - grain tank | 19'-4" | 19'-4" |
| Height - short side | 11'-9" | 11'-9" |
| Height - high side | 12'-9" | 12'-9" |
| Length - overall | 30'-7" | 30'-7" |
| PSI capacity*** | 11 psi | 23 psi/ 29 psi diamond float |
| Tractor Requirements (minimum) | | |
| Tractor horsepower | 250 hp | |
| Tractor hydraulics | 3 SCVs; 2,320 system psi | |
| Features and options | | |
| Vertical auger | STD with 20" diameter flighting with a 21" diameter tube | |
| Gearbox | STD with 90 degree, 3.5" - 4" pitch cut gears, 2:1 ratio | |
| PTO | STD with 1-3/4" diameter, 20 spline, 1000 rpm PTO | |
| Tracks | OPT; 36" x 100" contact area | --- |
| Diamond tread tires | --- | OPT; 900/60 R32 |
| Lug tread tires | --- | OPT; VF 1050/50 R32 |
| 5-point scale package | OPT | OPT |
| GT400 scale display | OPT | OPT |
| GT560 Autolog scale display | OPT | OPT |
| Remote scale readout | OPT | OPT |
| Roll tarp - manual | STD | STD |
| Safety chains | STD | STD |
| Adjustable spout | STD | STD |

Tracks

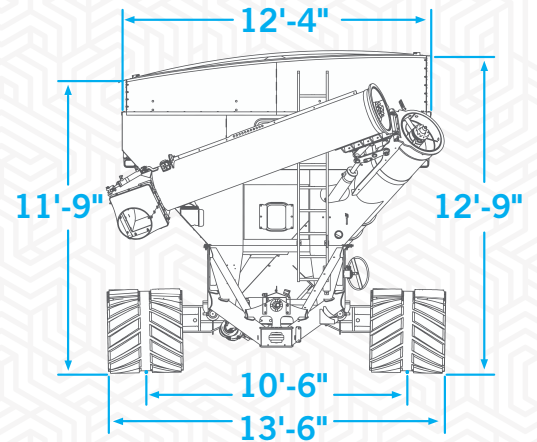

Flotation Tires

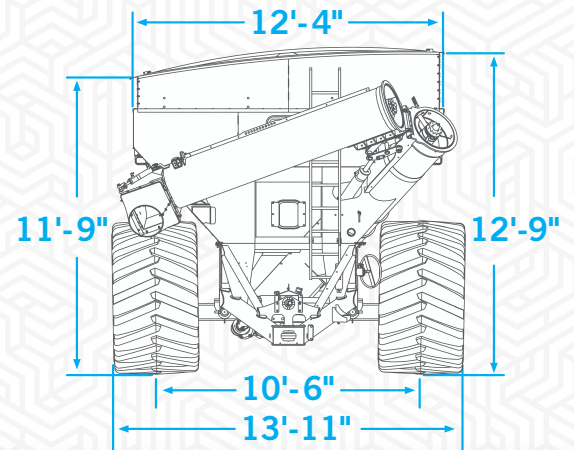

*Cart capacity and hitch weight are based on #2 corn at 15% moisture (56lb test weight). Cart capacity and hitch weight may vary based on crop type, grade, moisture and other environmental factors.

**Approximate with 15% moisture corn. Bushels/minute will vary with moisture content of grain and/or PTO rpm.

***Comparative PSI @ 3" soil penetration depth using 56 lb. test weight grain at 15% moisture at posted capacities.

