

KINZE

ROW CROP

PLANTERS

SUPERIOR ACCURACY AND EFFICIENCY



KINZE ACCURACY BOOSTS PROFITS FOR ALL YOUR CROPS

Seed depth, singulation, seed spacing, and seed-to-soil contact, are the four planter functions that affect crop performance, yields, and ultimately, revenue.

REALITY OF SKIPPED SEEDS

You only have one chance to put seed properly in the ground. Seed singulation, spacing, depth, and soil contact must all be done correctly to maximize germination, plant growth, yield, and profit (see page 4 for additional information).*

*Pioneer study, "Planting Outcome Effects on Corn Yield"

THE SPLIT ROW ADVANTAGE

Are you planting soybeans, rapeseed, or other narrow-row crops? With a single Kinze planter you can quickly and easily convert from wide to narrow rows and benefit from the increased accuracy and precise depth control that a Kinze planter provides.

CORN



Do you want an additional 70 000 € in revenue per 1 000 hectares in corn? Because corn yield is reduced 77 kg for every 1% in skips, you can tremendously increase your profit by switching to a faster and more accurate Kinze planter and improve singulation by 4.5%.

See how Kinze planter accuracy can potentially increase your revenue.
www.Kinze-Europe.com/resources/profit-calculator

SUNFLOWERS



Planting sunflowers? There is no need for different meters — simply change the meter seed disc and start planting. Improvement in singulation of 4% to 6% is typical when using the Kinze True Rate vacuum meter.

RAPeseed AND SOYBEANS



Reduce input costs and increase yield by planting with a precision split row planter. With improved accuracy and precise depth control germination is improved and yields are maximized.



Actual field results show that by planting rapeseed using Kinze split row technology, and using 35% LESS seed, rapeseed yields have improved 0.5 tonnes per hectare. This calculates out as an increase of 185 € profit per hectare, or 185 000 € per 1 000 hectares!

THE KEYS TO MORE PROFIT

Seed depth, singulation, seed spacing, and seed-to-soil contact, are the four planter functions that affect crop performance, yields, and ultimately, revenue.

SEED DEPTH

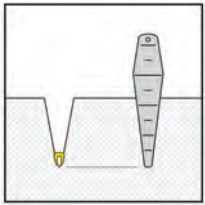

Correct and consistent seed depth is very important for proper seed germination and healthy root development. A kernel of corn, for instance, absorbs about 30% of its weight in water to properly germinate, and requires a proper planting depth for consistent moisture. Nodal roots must be established at the proper depth to reduce early season root lodging and improve drought tolerance.

SEED SPACING

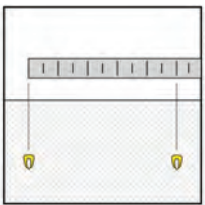

Greatest yields are realized when seeds are equally spaced and not competing for sunlight, moisture, and nutrients. While a seed meter may have a high rate of singulation, that does not ensure seeds are being equally spaced in the row. The measurement of how well a meter is releasing seed, and the variation of seed spacing that results, is called the Coefficient of Variation (COV).



Good COV



Poor COV

SINGULATION

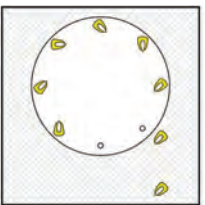

Singulation is the isolation of a single seed so it can be dropped into a seed trench without skips or doubles. When seeds are skipped, there are spaces where no seed is planted, and for every 1% drop in singulation, there will be a yield loss of 77.25 kg* per hectare. Doubles are created when two seeds are planted where there should only be one, which compromises the plant's performance due to sharing of sunlight, moisture, and nutrients.

*Pioneer population study, 2016

SEED-TO-SOIL CONTACT

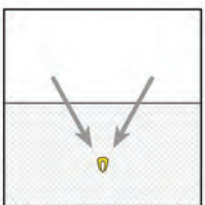

Many factors affect seed-to-soil contact including: soil conditions, planter hitch height, closing wheel alignment, closing wheel pressure, and closing wheel design. Making sure the planter is properly adjusted and the proper closing wheels are selected for the soil type are critical for good seed-to-soil contact for maximum and uniform emergence.

HIGH SPEED PLANTING SOLUTION

TRUE SPEED

Accurately achieve results at TRUE higher speeds.

Accurately plant at speeds from 5-19 km/h with the **True Speed®** high speed meter and plant up to twice the number of acres in a day versus a conventional meter.* By controlling the seed from the seed disc to placement in the seed trench, precise singulation and seed spacing are achieved regardless of seed size, shape, or coating. Industry leading low seed release point delivers superior spacing accuracy for precise seed positioning in the row.

*Subject to equipment, seed type and field conditions

- Easily replaceable industry leading wear components are long life and low cost — saving time and money
- A single, no-adjust singulator is all that is needed for planting corn, sugar beets, milo, cotton, and oil sunflowers
- Self-aligning delivery tube flighted belt does not stretch, or require removal after the planting season
- All access to the meter and delivery tube are tool-less for easy and efficient crop change-overs and maintenance
- Quick changeover of seed type is aided by a pivoting meter mount with lock-up, and easy to remove seed discs



Accuracy at your speed to maximize field efficiency and planting performance at speeds from 5-19 km/h.

	8 km/h	11,3 km/h	16 km/h	19,3 km/h
Hectars/hour (24 row planter)	10,5 ha/h	14,6 ha/h	20,6 ha/h	24,7 ha/h
Hectars/hour (16 row planter)	6,8 ha/h	9,7 ha/h	13,8ha/h	16,6 ha/h
% efficiency increase	-----	29%	50%	60%



Soybean
92 Cell, 30" / 20"



Soybean
46 Cell, 15" / 20"

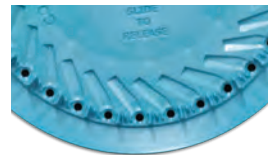

Corn
32 Cells



Sugar beets/milo
46 Cells



Cotton
46 Cells



Oil Sunflower
23 Cells



Rapeseed/Canola
104 Cells

True Speed availability¹

Model	Row Configuration
4805	24 row 70 cm
3605	16 row 70 cm ²
3605	12 row 70 cm ²
3505	8 row 70 cm ²

¹available on bulk fill only

²available with split row option

No adjust singulator

One singulator for all crop types requires no adjustment

Unique meter orientation

Perpendicular meter orientation provides seamless seed handoff from disc to delivery tube

Unique seed disc paddle design

Provides positive load-in and holds the seed for precise handoff to delivery belt

Kevlar reinforced belt

Wear components designed for long life and lower cost of ownership. Seed delivery belt has 600+ row hectares of wear life per row and removal is not required at end of season.

Lowest release points in the industry

For superior Coefficient of Variation (COV)

Brush wheel

- Keeps seed in control with a positive handoff from the seed disc to the delivery belt
- Longer life and low cost replacement provides lower cost of ownership

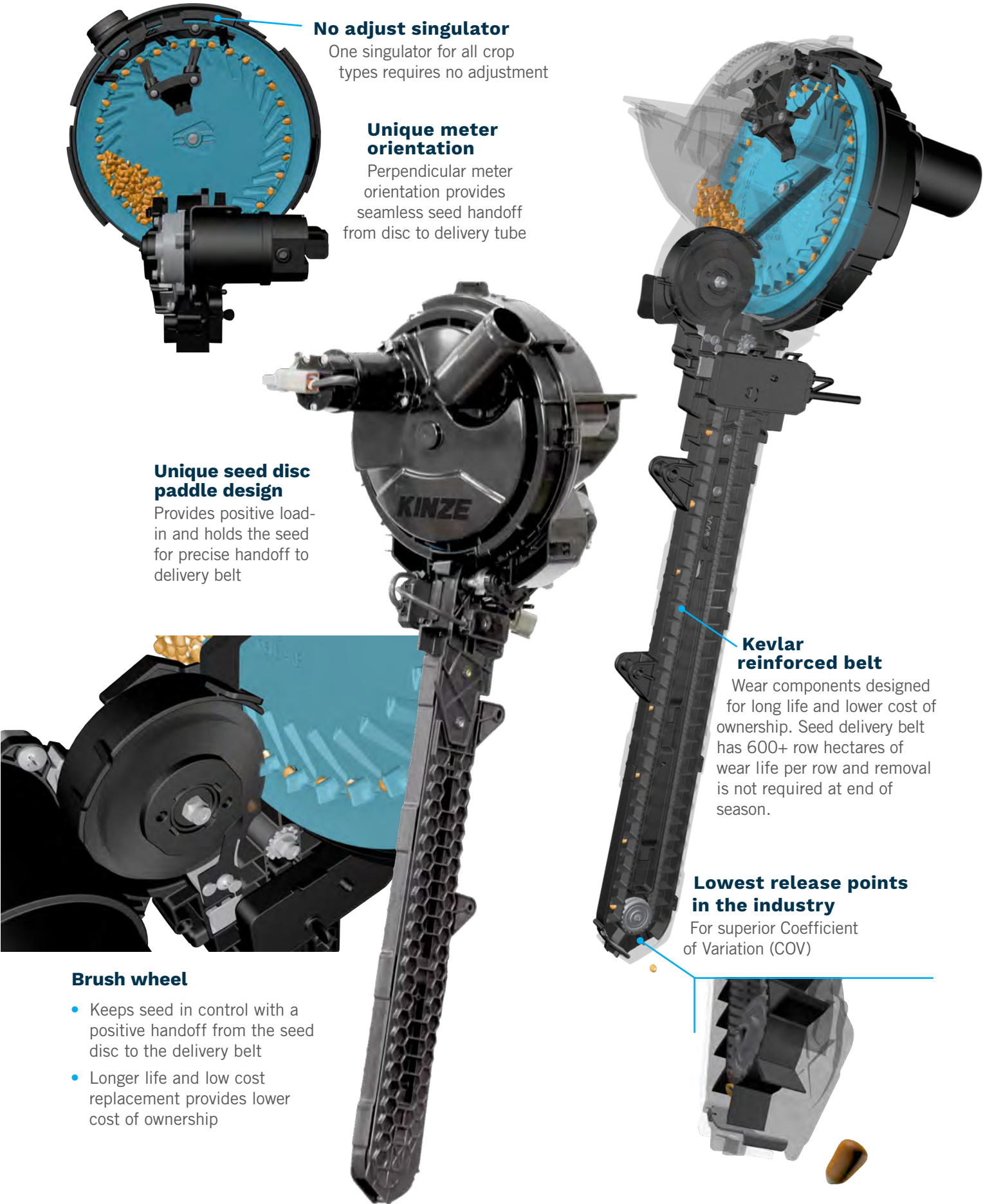

Automatically hit your TRUE target depth to increase yields.

True Depth hydraulic down force removes the guesswork from down force settings. It maintains a consistent seed depth for optimum emergence and root development along with minimizing sidewall compaction. During conventional or no-till planting, gauge wheel load is constantly measured, and automatically and instantly adjusts the down force, or up-lift, for each individual row. A large diameter hydraulic cylinder rod and cast load link make True Depth more durable than competitive systems and maintains a low cost of ownership.

True Depth offers lift assist on a split row planter, making it easier to raise your push row units for storage and when switching from beans to corn. This decreases the effort required to lock-up the row units by 30%, reducing operator fatigue and adjustment time.

- Large diameter hydraulic cylinder rod is more durable in rocky field conditions and at higher planting speeds
- Overall cylinder design is rebuildable for lower cost of ownership
- Durable cast load link design with fully potted and sealed electronics are built for long term wear life
- Single valve per row provides for clean and simple operation and ease of maintenance

**True Depth availability:
4805, 3605 and 3505**

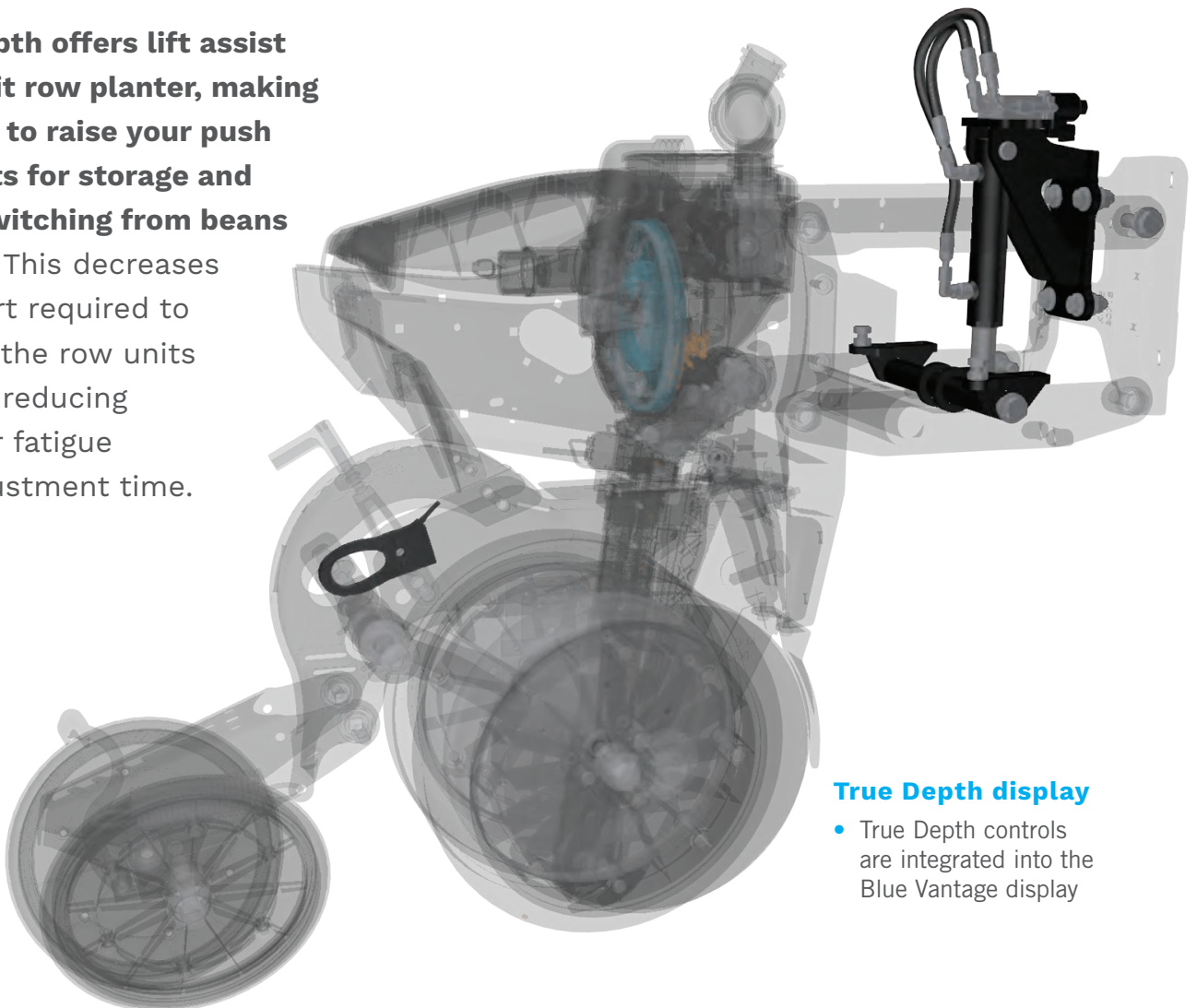

True Depth display

- True Depth controls are integrated into the Blue Vantage display

RESULTS FROM OUR CUSTOMERS

INCREASED RAPESEED YIELD WHILE REDUCING COSTS

“For the last two years we have used a Kinze 3500. Compared to conventional planting technology, it has enabled us to reduce our seeding rate by 35%- down to 350 000 seeds per hectare. At the same time, our annual average yield has increased by 0.5 tonnes per hectare. Kinze technology has reduced our seed costs while increasing our yields, to give us an increased profit of 185 € per hectare!”

~ Mr. Stanislav Zbořilek (Czech Republic)

INCREASED CORN YIELD

“I have 2 years’ experience planting with a Kinze split row machine. By increasing seeding populations, which has cost an extra 60 € per hectare, I have realized an additional yield with my corn crop of 1.6 tonnes per hectare. This is due to the Kinze split row technology and 99% singulation with my corn seeding - an increase in yield of 16-18%. And I want to emphasize these are the results of 3 months of drought before harvest!”

~ Mr. Viktor Skravenski (Bulgaria)

REPEAT CUSTOMER

“We cultivate a total of 1 500 hectares, of which 700 hectares are spring crops. I bought a Kinze planter again because I got one 10 years ago and so far it is doing great. Its best qualities are productivity and precise planting. For so long, we have rarely had to buy parts, and it accurately singulates the number of seeds per acre.”

~ Dr. Gocho Gochev (Bulgaria)

ACCURATE AND SIMPLE TO OPERATE

“We faced an urgent need to radically change the technology of planting, mainly for corn and sunflower. Thus we looked for a planter that meets the following requirements: accuracy of planting, precise delivery of set seed rate, and the planter had to be simple to transport, operate, and maintain. This is why we opted to buy the Kinze 3605 Blue Drive.

The main advantages of this planter are the Blue Vantage system and the simplicity of setting up the planter itself. The Blue Vantage is a monitor that is very easy for the operator to handle.

We planned to plant more than three thousand hectares of sunflower and corn this year. The planter did the job well. We will definitely recommend this planter to other farms because it ensures all that is needed for high-quality planting and easy operation.”

~ Andriy Pasos, Agricultural Firm Luga-Nova (Ukraine)

HIGH YIELDS WITH NO-TILL TECHNOLOGY

“We have a Kinze 12R planter and utilize the no-till technology, which saves a lot of fuel, time and labor costs. Our soils are weak, and in order to be profitable we cannot produce at high costs. With the Kinze planter, we planted 1 500 hectares of rapeseed, sunflower and corn and we are very happy with the yields.”

~ Vesko Pishchiiski, Tanyo Enchev Agricultural Cooperative (Bulgaria)

Effortlessly handle a variety of seeds at a TRUE metered rate.

The **True Rate**® vacuum meter, with its wide selection of easy-to-change seed discs, can plant at speeds up to 13 km/h as field conditions allow. The durable and easily serviceable design requires only one singulator for easy operation, optimum performance, and low cost of ownership.

- 3 o'clock seed release for consistent seed drop regardless of planter speed or population
- One easy to adjust singulator for all crop types to dial in singulation accuracy
- Engineered polymer seal provides long wear life and ensures consistent vacuum levels
- Tapered edge seed disc for reduced seed contact during release; improved COV, especially on slopes
- Quick crop changeover with a single button meter cover release and quarter turn quick release seed disc hub

True Rate vacuum meter seed discs

Many color-coded seed discs are available for planting different crops, seed sizes, and populations.



Sunflower (2,3,4) & Small Sweet Corn
40 Cells



Corn
40 Cells



Soybean
60 and 120 Cells



Canola & Rapeseed*
83 Cells



Sugar beet/Milo
60 Cells



Cotton
60 Cells



Wheat
231 Cells



Edible Beans
(Pinto, Great Northern)
60 Cells



Edible Beans
(Black, Turtle, Navy & Popcorn)
60 Cells

*Canola and Rapeseed should only be planted with planters equipped with row unit hoppers

Superior singulation

One adjustable seed singulator for all seed types and sizes



Superior loading

- » Seed pool shape promotes 100% clean out
- » Seed channel ensures every seed cell is loaded, preventing skips

Drives

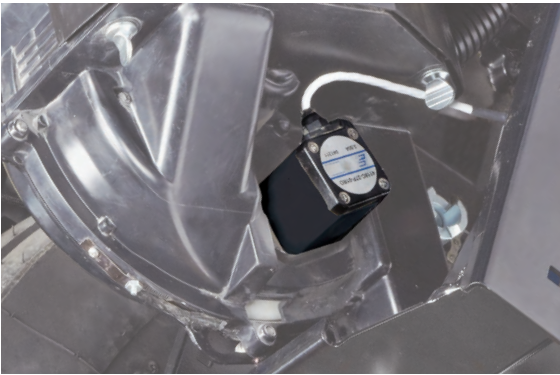

Blue Drive electric drive

No drive shafts, no chains, no clutches and no gearboxes. Available with True Speed & True Rate meters only.



Ground contact drive

Smooth, reliable and easy to operate. Uses spring-loaded tires. No clutches. No chains to remove for transport.

Model	Meter options*			Drive options*	
	True Speed high speed meter	True Rate vacuum meter	Mechanical meter	Blue Drive electric drive	Ground contact drive
3005	–	•	•	–	•
3035	–	•	•	–	•
3205	–	•	•	–	•
3505	•	•	–	•	•
3605	•	•	–	•	•
4805	•	•	–	•	–

*Not all features are available with all configurations. Visit www.Kinze-Europe.com/planters or your local dealer for details.

Clutches



Electric row clutches

Clutch control, up to 36 rows, in two or three row sections. Stop seed flow by turning off seed meters (and planter sections) based on field mapping and previously planted areas.



Point row clutches for half-width planting

For ground contact drive
(Not required for electric drives).

TRUE. BLUE. Advantage.

You require durable equipment to handle tough conditions, while being simple to operate and easy to maintain. With nearly 60 years of innovation and optimization, we continue to push industry performance boundaries by developing dependable, innovative, and easy to use agricultural equipment that delivers **TRUE Performance** when you need it.

Colored hydraulic handle grips for easy hose identification and hook-ups



Parallel arm
double bushing design

Double row bearing
disc opener



Long life
inner scraper
High speed scraper shown

PLANTER PERFORMANCE UPGRADES

05 SERIES

Spend less time in the shop and more time in the field with the 05 series planter enhancements. Double the hectares between service intervals with upgrades to row unit wear points for improved durability and ease of maintenance.

Variable displacement hydraulic piston PTO pump (2 SCVs)

Available on 4805 model only



KINZE



Redesigned hydraulics for simple operation and faster lift speed



Bulk fill entrainer design supports various crop seed types and increased rates



High efficiency, quiet vacuum fan and 1.5" vacuum hoses for easier meter removal and serviceability

2" hoses on 3005 and 3035

BLUE VANTAGE

Simple. Accurate. Intuitive.

Blue Vantage® is the industry's easiest-to-use dedicated planter display. Designed by Kinze and exclusive to Kinze planters, this innovative, clean, and streamlined display provides simple, accurate, and intuitive planter control for high-productivity planting. Factory presets remove the labor and guesswork from setup, while a dedicated planting screen provides all critical information at one glance during planting. Built-in diagnostics provide easy and efficient troubleshooting.

- Only 3 clicks are required to start planting with the rugged and simple-to-use touch-screen
- A single screen displays all critical information, and factory presets eliminate setup guesswork
- See clearly behind the planter with the standard rear-facing camera; 3 additional cameras are optional
- Remote viewing of the Blue Vantage screen when logged into a Blue Connect account
- Adjust prescription map populations after importing them - directly from the plant screen
- Supports planting wheat with True Rate vacuum seed meter

Row-by-row graph includes population, singulation, and down force information

Customizable side bar displays most used information

Task bar for easy display navigation

Plant screen

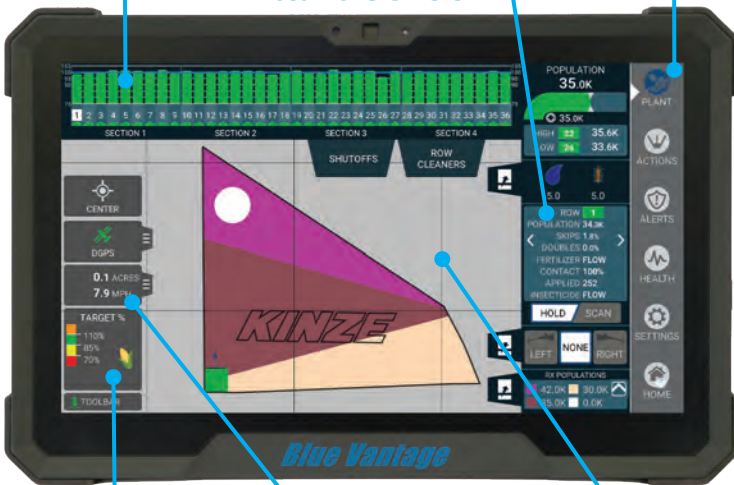

Adjustable map data legend

Acres planted, speed, task bulk fill scale & Blue Connect information

Touch screen with pinch zoom control

Blue Drive and Blue Vantage availability

Model	Row Configuration
3505	8 Row 70 cm*
3605	12 Row 70 cm*
3605	16 Row 70 cm*
4805	24 Row 70 cm

* Split row option available

Climate FieldView

Adding a **FieldView Drive adapter kit** and an iPad, downloaded with the Cab App, allows you to seamlessly upload data to your FieldView account using a Kinze Blue Vantage display. Check the FieldView Compatibility Guides at support.climate.com.



New for 2025: Split Screens



All plant screen map layers can be viewed in single- or split-screen mode and enable you to monitor two planting maps at the same time. A simple touch of the PLANT icon toggles the screen between modes.

Shared Mapping (Map Sync®)



Kinze Blue Connect® is a remote cloud-based data storage solution for planting and field data.

It exchanges data with the Blue Vantage display whenever a customer-supplied internet connection is available and logged in to a Blue Connect account. The shared mapping feature **Map Sync®** enables two or more planters equipped with Blue Vantage displays to share planting coverage data to plant in the same field at the same time. Enables remote viewing of display by customers and dealers, and wireless software updates.



Integrated down force screens



- True Depth map displays the target gauge wheel load as a percentage of ground contact
- Monitor and control the down force settings directly from the display plant screen

Task set-up



- One screen field set-up with no grower, farm, or field information required to plant
- Vacuum and bulk fill requirements for different crops are factory preset and do not require any unlock codes

Camera options



- View up to four planter-mounted cameras
- First camera is factory installed and rearward-facing
- Three additional cameras can be mounted as needed

BLUE DRIVE TRUE confidence.

Blue Drive® is a Kinze designed electric drive system that is simple, reliable and accurate, giving you confidence during the planting season. System design delivers enhanced section control and accurate seed placement, ensuring maximized profitability.

- **Ethernet connectivity provides reliable, faster connection** and speeds for quick software updates and troubleshooting
- Proprietary, **non-ISOBUS architecture** to optimize the design and experience for Kinze users
- **Designed to be easily updated with software upgrades** and additional features that require no costly unlock codes.
- **Kinze Blue Drive electric drive equipped planters** are covered by an industry leading **2-year hitch pin to closing wheel warranty**

ROW UNITS

3005 SERIES

1. Heavy duty shanks with triangular reinforcement to max side-load strength
2. 25 cm row unit travel handles changing field conditions
3. Double parallel arm bushings with larger wear areas to eliminate arm replacement
4. Double row bearing disc opener for increased durability
5. Improved scraper material lasts two times longer than the '00 Series inner scraper
6. True Speed scraper

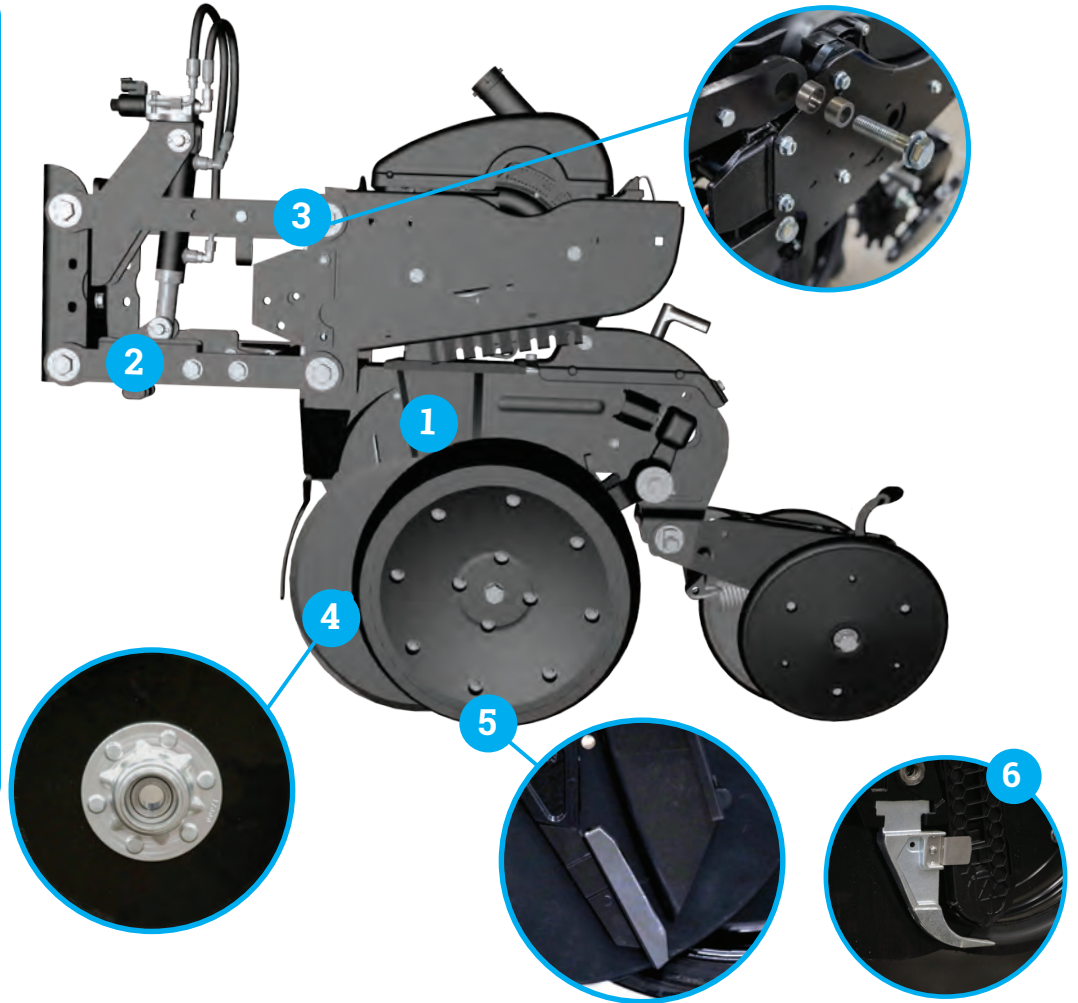

Row unit shown with bulk fill mini-hopper

05 SERIES

Common features on both 3005 and 4005 series row units

- Hardened, replaceable large diameter double parallel arm bushings have more wear area and are oil impregnated for double the wear life and to eliminate parallel arm replacement
- Inner scraper material upgraded for twice the wear life
- Load equalizing gauge wheels for uniform depth control, even in heavy residue or rugged planting conditions
- Down force options depending on configuration: True Depth hydraulic, pneumatic, or springs

4005 SERIES

1. Cast iron shanks for greater reliability and durability
2. 30.5 cm row unit travel ensures ideal seed depth in varying terrains
3. Double parallel arm bushings with larger wear areas to eliminate arm replacement
4. Double row bearing disc opener for increased durability
5. Improved scraper material lasts two times longer than the '00 Series inner scraper
6. True Speed scraper

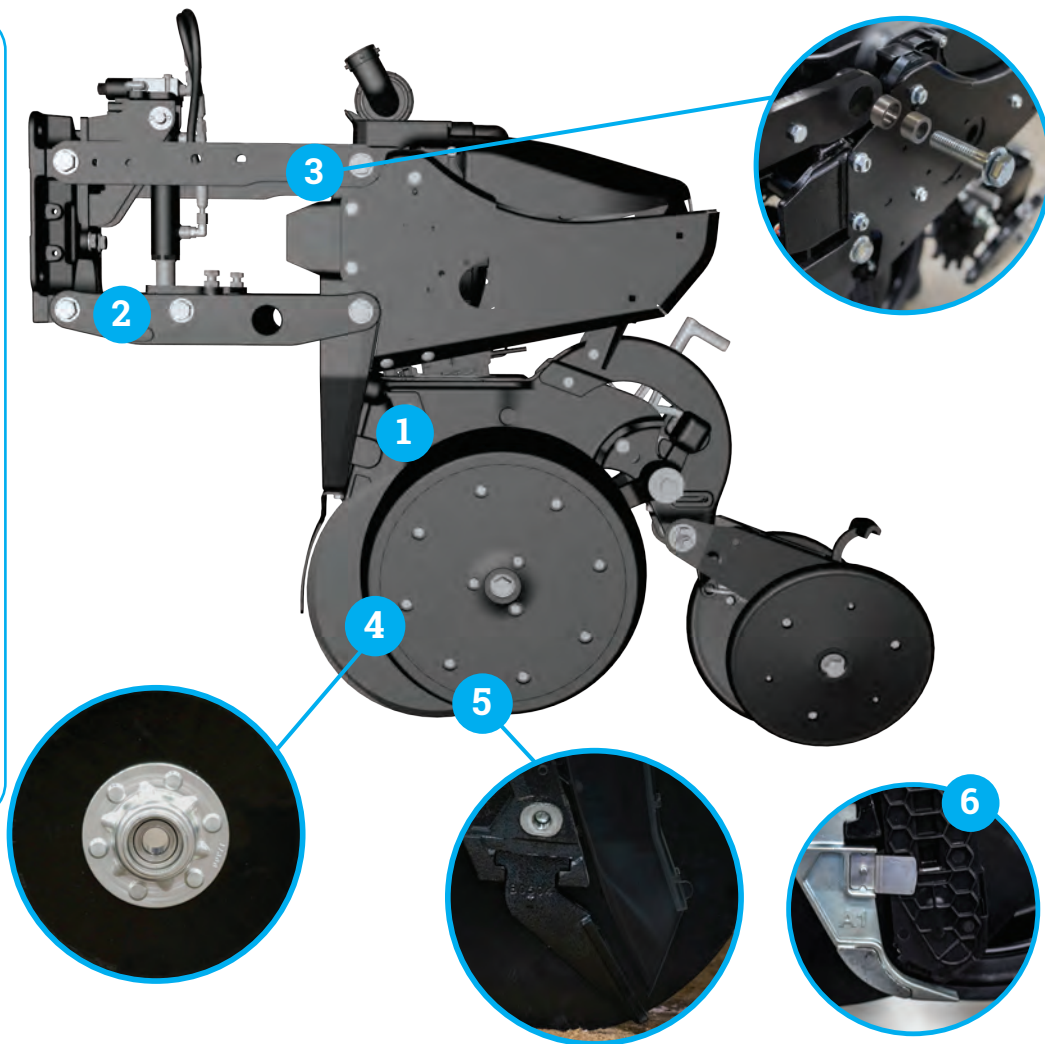

Row unit shown with bulk fill mini-hopper

Row unit hoppers

On planters not equipped with bulk fill hoppers, durable row unit hoppers are available in two sizes.



4005
105 liter high-capacity
row unit hopper



4005 and 3005
66 liter row unit hopper

Insecticide and granular chemical options available on 3005 and 4005.

Bulk fill seed delivery

More seed types. More seed sizes. More seeding rates. The 05 Series bulk fill entrainer delivers the variety of seeds you plant during a busy planting season. It's an air pressurized bulk fill seed delivery system, requiring no mechanical agitation, with capacities up to 4 230 L. The system handles various seed sizes, higher populations, and supports planting speeds up to 19 km/h. Shut off gate enables easy service or cleanout for seed remaining in the hoppers.



Electronic scale package

Bulk fill seed hoppers are weighed individually allowing operator to see weight per hopper and hectares remaining to empty. Package includes a catwalk mounted remote scale display for even filling. Bulk fill scales are required for the active weight transfer feature.

Increased crop compatibility

- Corn
- Beans
- #4 sunflowers
- Confectionery sunflowers
- Grain sorghum
- Cotton
- Canola
- Sweet corn
- Sugar beets
- Hemp
- Cover crops

HYDRAULIC WEIGHT TRANSFER

Hydraulic weight transfer

Hydraulic weight transfer distributes the weight from the center of the planter evenly across all rows, resulting in higher yields from less pinch row compaction.



On planters equipped with a bulk fill scale package and Blue Drive electric drive, the hydraulic weight transfer becomes ACTIVE. The weight of the bulk fill hoppers is constantly monitored, and the amount of weight transfer changes based on how much seed is in the hoppers.

Yield loss from pinch row compaction

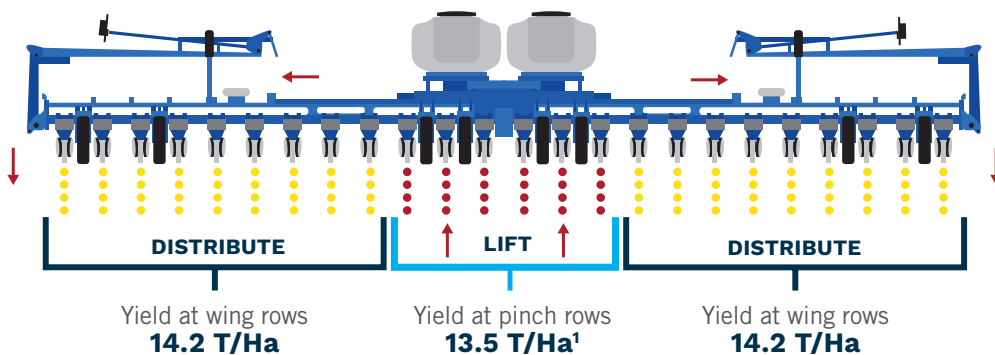
The middle 6 rows of the planter next to the transport tires.



Three ways field compaction reduces yield:

-  Reduces oxygen to the plant roots
-  Reduces water to plant roots
-  Restricts root development

¹Data based on research from Beck's Hybrids 2014 Practical Farm Research report, available at www.beckshybrids.com.

THE KINZE SEED TUBE COUNTS EVERY SEED

- » High-definition, two-piece, optical seed sensor
- » Counts every seed, even at higher populations
- » Monitors multiples, skips and spacing at higher population rates
- » Automatically self-calibrates for dust
- » Instant response to population changes
- » Large seed tube minimizes seed bounce within the tube, ensuring consistent seed spacing

DISPLAYS

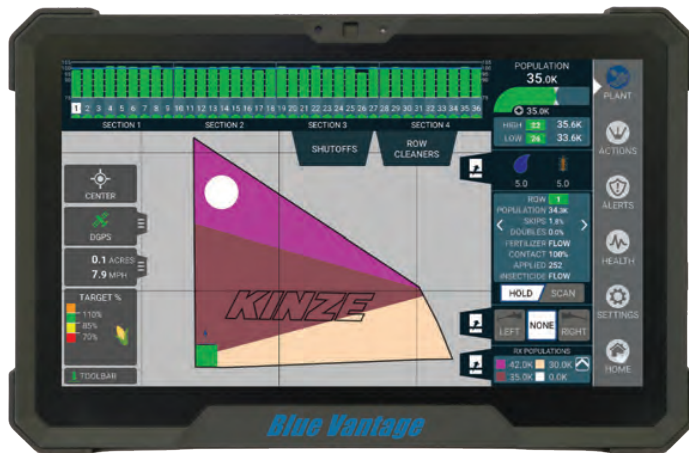

BLUE VANTAGE

- » Built in diagnostics
- » Camera options
- » Integrated down force screens
- » Shared mapping

AG LEADER® INCOMMAND™ 1200

- » Tablet-like interaction
- » Split screen view
- » Advanced planter control

DISPLAY AVAILABILITY*

Model	Blue Vantage	KPM III	AG LEADER
3005	-	●	-
3035	-	●	-
3205	-	●	●
3505	●	●	-
3605	●	●	●
4805	●	-	-

*Because of ongoing technological advances, visit www.Kinze-Europe.com for the most current information on displays and monitors



KPM III

- » Easy to use
- » Economical
- » Real-time results by row or average of the entire planter
- » Displays skips, multiples, singulation, planting rate graphs, speed and more

Closing Wheels



Spiked

- » Self-gauging; stays above the seed trench
- » Dual wear wheel
- » Works well in all soil conditions
- » Used with all speeds, especially high speed



Rubber "V"

- » Works well in conventional tillage soil



Cast Iron "V"

- » Provides extra weight to close the trench
- » Works well in rocky and no-till soil

Residue Wheels

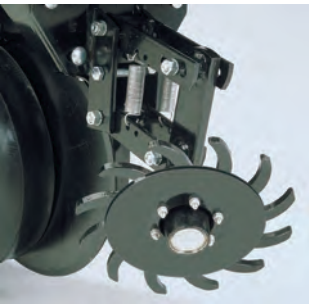

Row Unit Mounted Single Residue Wheel

- » 31 cm diameter wheel, 12 curved tines
- » 3-position mounting to vary aggressiveness
- » Rugged spring-loaded parallel linkage
- » Ideal for mulch till
- » Available on 3005 series planters only



Coulter Mounted Residue Wheel

- » 31 cm free-floating diameter dual wheel system
- » 12 curved tines with interlocked or staggered mountings
- » 11 depth settings in 6 mm increments - easily adjustable
- » Requires no-till counters
- » Fairly aggressive
- » Work well in no-till and minimum-till

No-Till Coulters



19 mm (3/4"), 13 Flutes

- » 40 cm diameter blades
- » Works well in all soil conditions
- » Medium aggressiveness

25 mm (1"), Bubbled

- » 40 cm diameter blades
- » Ideal for sandy soils

25 mm (1"), 8 Flutes

- » 40 cm diameter blades
- » Works well in slower speed applications
- » Most aggressive

- » Uses less down pressure

Gauge Wheels



Spoked gauge wheels

- » Allows mud and debris to fall away from the opener blades
- » Ideal for wet conditions
- » Works well in any tillage
- » Standard feature on all planter models

Fertilizer opener options*

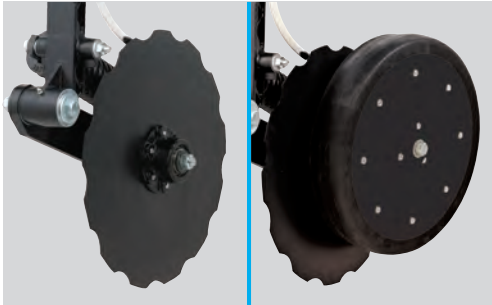

Notched single disc openers - Liquid or Dry

- Notched 40 cm diameter blade
- Adjustable down pressure – depth range 2.5 cm - 10 cm
- For no-till and conventional tillage
- Optional depth gauge wheel for conventional till situations



Heavy duty single disc openers - Liquid

- 45.75 cm diameter blade
- Adjustable down pressure – depth range 5 cm - 12.75 cm
- For no-till or conventional tillage, harsh conditions, higher application rates, and rocky soil



Double disc openers - Liquid or Dry

- 38 cm diameter V-blade
- Adjustable coil spring down pressure
- Accurate fertilizer placement
- For conventional tillage
- Plant at speeds up to 10 km/h



Fertilizer tube in-furrow - Liquid

- Maximize fertilizer effectiveness with drop tubes behind row unit seed tubes to deliver liquid fertilizer directly in the furrow
- Very low fertilizer flow rate for pop-up applications
- For any tillage situation—used with low fertilizer rates and lower salt content fertilizers

Fertilizer pump options

- » John Blue piston pump option with flow dividers*
- » Hydraulically driven centrifugal pump (4805 and 3605) to allow section shut-off and variable rate capability

*Option includes pump mounting bracket, sprockets, drive components and flow divider.

*Consult with your dealer for fertilizer opener compatibility

FERTILIZER AVAILABILITY

Model	Size	Seed Hopper Style	Liquid Fertilizer Capacity	Dry Fertilizer Capacity
3005	8 Row	Row Unit	1 140 L - (2) 570 L tanks	1 600 L - (2) 800 L tanks or 1 000 L - (4) 250 L tanks
	6 Row	Row Unit	1 140 L - (2) 570 L tanks	750 L - (3) 250 L tanks
3035	8 Row	Row Unit	1 140 L - (2) 570 L tanks	1 000 L - (4) 250 L tanks
3205	12 Row	Row Unit	1 515 L - (2) 575 L tanks	—
3505	8 Row	Bulk Fill ¹ 1 760 L	1 140 L ² - (2) 570 L tanks	—
	8 Row	Row Unit	1 140 L ² - (2) 570 L tanks	1 600 L ³ - (2) 800 L tanks
	6 Row	Row Unit	1 140 L ² - (2) 570 L tanks	750 L - (3) 250 L tanks
3605	16 Row	Bulk Fill ¹ 2 820 L	1 515 L - (2) 757 L tanks	—
		Row Unit	2 270 L - (4) 567 L tanks	2 820 L - (2) 1 410 L tanks or 2 000 L - (8) 250 L tanks
	12 Row	Bulk Fill ¹ 2 820 L	1 515 L - (2) 757 L tanks	—
		Row Unit	2 270 L - (4) 567 L tanks	2 820 L - (2) 1 410 L tanks or 1 500 L - (6) 250 L tanks
4805	24 Row	Bulk Fill 4 230 L	2 280 L - (2) 1 140 L tanks	3 020 L - (1 tank)
		Bulk Fill 1 760 L	—	6 130 L - (1 tank)
		Row Unit	3 800 L - (2) 1 900 L tanks	5 150 L - (1 tank)

¹Fertilizer option not compatible with split row option, ²Fertilizer with split row or twin row are in-furrow only, ³Dry Fertilizer not available with twin row option

SPLIT ROWS

PLANT YOUR MAJOR CROPS WITH ONE PLANTER

Plant your major crops with a Kinze split row planter for greater accuracy. The unique combination of parallel toolbars and the Kinze exclusive push row units enable better residue flow and seed placement than other narrow row options. Plant narrow row no-till soybeans between last season's corn stalks to maximize emergence and minimize tire tread wear. Easily lock up the front row units to plant 70 cm wide row crops with the same planter.

EVEN ROW, SPLIT ROW OPTION



Exclusive Push Row Units
Available on rigid frame 3005 model and all pivot fold models.

Planting 35 cm no-till beans between last season's cornstalks? Get more accurate seed placement and depth, a smoother planter ride, and continue to function at full planter width saving you time with the Kinze even row push unit. Decrease tire wear and tear by running tractor tires between last season's corn rows.



Spring-Loaded Over-Center Row Unit Lock-Ups
Easily switch from split rows to standard width rows in minutes.

SPLIT ROW AVAILABILITY*

Model	Size	Split Row Spacing	Even Row Option
3005	6 Row 70 cm	35 cm	-
3005	8 Row 70 cm	35 cm	-
3505	8 Row 70 cm	35 cm	●
3605	12 Row 70 cm	35 cm	●
3605	13 Row 70 cm	35 cm	●

*Not all features are available with all configurations. Visit www.Kinze-Europe.com or your local dealer for details.

No-Till Wheat

Image below planted with Kinze split row technology on the left, conventional seed drill on the right; wheat planted with split row is visibly stronger because of more oxygen and nutrients compared to the wheat planted with the conventional seed drill.

Bioteks - Bulgaria, Orechovica



SPLIT ROW ADVANTAGES

Better Trash Flow

Kinze's exclusive push row units and parallel bar design allow for better residue flow resulting in better seed placement accuracy than other narrow row planters. Perfect for narrow row crops like soybeans, sunflowers, and rapeseed.

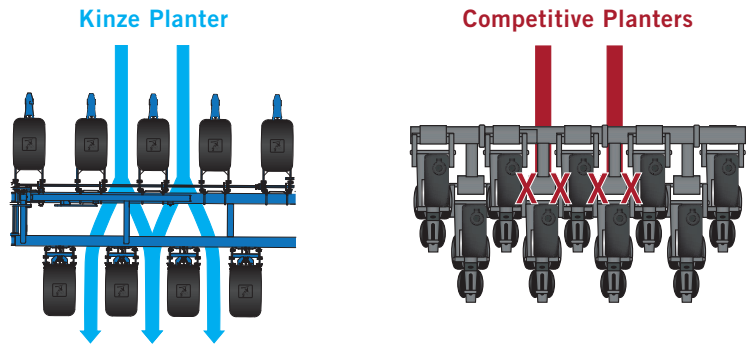

Split Row Sunflowers Out-Perform Traditional Row Spacing

In a 2017 study conducted by North Dakota State University, split row planted sunflowers out-yielded those planted in traditional wide rows by an average of 338 kg (0.338 tonnes) per hectare. At an average price of 300 € per tonne for sunflowers, this equates to 101 € more profit per hectare.*

*North Dakota State University study, "2017 Oil Sunflower Spacing & Seeding Rate Trial at Minot"

NO-TILL ADVANTAGE¹



Excellent
Erosion Control



Soil Moisture
Conservation



Minimum Fuel
& Labor Costs



Builds Soil
Structure & Health

No-Till Soybeans Out Yield Conventional Tillage

Averaged over three years, in 4 out of 6 studies, soybeans averaged yield differences that ranged from 25 to 94 kg/ha.²

¹University of Nebraska-Lincoln, Institute of Agriculture and Natural Resources, CropWatch
²Farm Progress

No-Till Wheat

Planted with Kinze 3605 at 35 cm
with liquid fertilizer
-Moldova, Cupcini

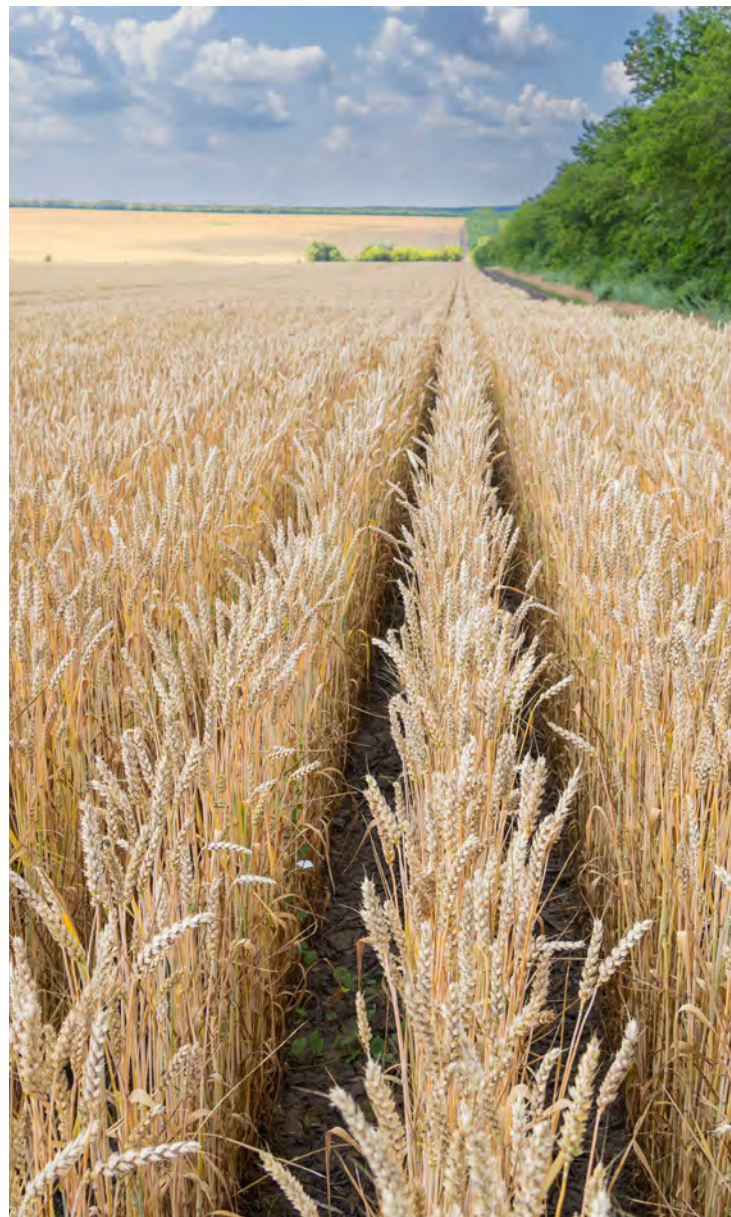

MODEL REVIEW

RIGID FRAME



3005

WING FOLD



3035



3205

PIVOT FOLD



3505



3605

FRONT FOLD



4805



A model of versatility of what we put in all our planters, the 3005 Kinze planter is an adaptable, small-frame hitch pin planter. Its bolt-together design can easily switch from standard to split rows and converts from 70 cm to 35 cm row spacing in minutes. When equipped with double frame, it can be outfitted with dry or liquid fertilizer along with optional split rows. Lower inputs and equipment costs up front allow you to customize and configure the 3005 planter to match your farm.

- Improved durability, longer wear life, and lower cost of ownership from O5 Series row unit upgrades
- Accuracy at speeds up to 13 km/h, as field conditions allow, with the True Rate vacuum meter
- Efficient fertilizer application with up to 1 140 L of liquid or up to 1 600 L of dry fertilizer capacity
- Optional double frame enables both split row and fertilizer options at the same time
- Contact drive system with easy-access seed rate transmissions
- Plant both wide and narrow row width crops with split row option
- Rigid frame design with self-leveling hitch

Features & options²

True Rate vacuum seed meter

O5 Series row unit enhancements

Ground contact drive

Finger pick-up meter

Brush meter

Rigid frame

Self-leveling hitch

Split rows

Liquid fertilizer available on 8R Split Row

Dry fertilizer

¹Minimum tractor power requirement dependent upon planter configurations and chosen options.

²Not all features are available with all configurations. Visit www.Kinze-Europe.com/planters or your local dealer for details.



 MINIMUM¹
80 HP

The 3035 Kinze planter is a feature-packed narrow transport solution for many farms where narrow transport width is critical for navigating narrow roads or getting in to smaller fields. The double frame wing fold design, that enables the use of dry or liquid fertilizer, provides maximum versatility in a small package.

- Improved durability, longer wear life, and lower cost of ownership from O5 Series row unit upgrades
- Accuracy at speeds up to 13 km/h, as field conditions allow, with the True Rate vacuum meter
- Contact drive system with easy-access seed rate transmissions
- Efficient fertilizer application with up to 1 140 L of liquid or up to 1 000 L of dry fertilizer capacity
- Fertilizer openers and row units on wings fold together for a narrow transport width of 2.95 m

Features & options²

True Rate vacuum seed meter

O5 Series row unit enhancements

Ground contact drive

Narrow transport width

Finger pick-up meter

Brush meter

Wing fold frame

Liquid fertilizer

Dry fertilizer

¹Minimum tractor power requirement dependent upon planter configurations and chosen options.

²Not all features are available with all configurations. Visit www.Kinze-Europe.com/planters or your local dealer for details.



The 3205 wing fold planter is an economical solution for many operations—perfect for the farmer moving from a 6-row to a 12-row planter or a growing operation in need of a second planter for smaller field sizes. Standard ground contact drive works seamlessly with True Rate vacuum meters for accurate seed placement. Wing fold frame provides center flex for terraces and rolling terrain; the proven design has minimal hydraulic requirements and low cost of ownership.

- Improved durability, longer wear life, and lower cost of ownership from O5 Series row unit upgrades
- Accuracy at speeds up to 13 km/h as field conditions allow, with the True Rate vacuum meter
- Efficient fertilizer application with up to 1 515 L of liquid fertilizer capacity
- Easily navigate terraces and rolling terrain with the wing fold frame design incorporating 25 degrees of center flex
- Economical planter with minimal hydraulic requirements and low cost of ownership

Features & options²

True Rate vacuum seed meter

O5 Series row unit enhancements

Ground contact drive

18 cm x 18 cm toolbar

25 degrees toolbar flex

Wing fold frame

Brush meter

Finger pick-up meter

Electric clutches

Liquid fertilizer

¹Minimum tractor power requirement dependent upon planter configurations and chosen options.

²Not all features are available with all configurations. Visit www.Kinze-Europe.com/planters or your local dealer for details.



Uniquely positioned as a small frame basic or advanced technology planter for smaller farms or small fields, the Kinze 3505 pivot fold planter, with split rows or 17.5 cm twin rows, is simple to operate, high performing, and now available with True Speed high speed meters. Performance optimized with other optional high tech features—Blue Vantage display, Blue Drive electric drive, and True Depth hydraulic down force—it accurately places your seed for increased productivity and profits at speeds up to 19 km/h.

- True high-performance split row planting achieved with True Speed high speed or True Rate vacuum meters and Blue Drive electric drive
- Simple and easy to use Blue Vantage display with Map Sync™ shared field coverage data, and up to four cameras
- Consistent seed depth control with the optional True Depth hydraulic down force system
- Exceptional seed handling capabilities with upgraded bulk fill entrainer—up to 11 different crops
- Fewer stops with 1 760 L bulk fill hopper
- Accuracy at speeds from 5-19 km/h, as field conditions allow, to plant up to twice the number of hectares in a day with the True Speed vacuum meter
- Narrow transport and easy serviceability achieved with double frame, lift and pivot folding frame design
- Improved durability, longer wear life, and lower cost of ownership from 05 Series row unit upgrades
- Efficient fertilizer application with up to 1 140 L of liquid or 1 600 L of dry fertilizer capacity

Features & options²

True Speed high speed meter

Blue Drive electric drive and Blue Vantage display

True Depth hydraulic down force

Liquid or Dry Fertilizer; Blue Vantage controlled Liquid Fertilizer

Split row (available with fertilizer)

Up to 4 planter mounted cameras

True Rate vacuum seed meter

Narrow transport

Opt. Electric Clutches

Twin row 17.5 cm spacing on 70 cm centers

Ground contact drive

Electric single row control

Pneumatic down pressure

¹Minimum tractor power requirement dependent upon planter configurations and chosen options.

²Not all features are available with all configurations. Visit www.Kinze-Europe.com/planters or your local dealer for details.



Less than 3.2 meter transport width in 70 cm configurations

MINIMUM¹
240 HP

Outfitted with split row units, the 3605 is uniquely suited as a dedicated 35 cm soybean planter, along with the versatility to plant crops in 70 cm rows. Equipped with dry or liquid fertilizer, bulk fill or row unit hoppers, and simple to use high tech features — Blue Vantage display, Blue Drive electric drive, and True Speed high speed meters — it delivers the precision required for maximum yields and profits at speeds up to 19 km/h.

- True high-performance and accurate planting with True Speed or True Rate vacuum meters and Blue Drive electric drive
- Simple and easy to use Blue Vantage display with Map Sync™ shared field coverage data, and up to four cameras
- Improved durability, longer wear life, and lower cost of ownership from O5 Series row unit upgrades
- Exceptional seed handling capabilities with upgraded bulk fill entrainer — up to 11 different crops
- Consistent seed depth control with the durable True Depth hydraulic down force system
- Follow rolling terrain with a 3-section pivot fold frame with 14 degrees of wing flex
- Reduced pinch row compaction with 2 820 L bulk fill seed capacity with a hydraulic weight transfer system
- Narrow transport and easy serviceability achieved with double frame, lift and pivot folding frame design
- Efficient fertilizer application with up to 2 270 L of liquid or 2 820 L of dry fertilizer capacity
- Plant narrow row width crops with split row option

Features & options²

True Speed high speed meter

True Depth hydraulic down force

Active³ hydraulic weight transfer

Blue Vantage controlled liquid fertilizer

Blue Drive electric drive and Blue Vantage display

True Rate vacuum seed meter

Up to 4 planter mounted cameras

Narrow Transport

Split row

Liquid or dry fertilizer

Articulating clevis hitch



¹Minimum tractor power requirement dependent upon planter configurations and chosen options.

²Not all features are available with all configurations. Visit www.Kinze-Europe.com/planters or your local dealer for details.

³Active hydraulic weight transfer only with bulk fill scales and Blue Drive.



MINIMUM¹
400 HP

Equipped with Blue Vantage display, Blue Drive electric drive, True Speed high speed meters, rugged cast row units, and True Depth hydraulic down force, the 4805 delivers unrivaled seed control and placement at speeds up to 19 km/h. The front fold, 3 section, high clearance frame, equipped with larger front mounted tires and transfer, supports large seed and fertilizer capacities while reducing pinch row compaction.

- True high-performance and accurate planting with True Speed or True Rate vacuum meters and Blue Drive electric drive
- Simple and easy to use Blue Vantage display with Map Sync™ shared field coverage data, and up to four cameras
- Improved durability, longer wear life, and lower cost of ownership from 05 Series row unit upgrades
- Reduced pinch row compaction from bulk fill with an active hydraulic weight transfer system
- Fewer stops and improved efficiency with up to 3 800 L liquid fertilizer controlled by Blue Vantage or up to 6 130 L dry fertilizer on board
- Lower tractor hydraulic requirements and only two SCVs required with PTO variable displacement pump
- Follow rolling terrain easily with a 3-section front fold frame with 30 degrees of wing flex
- Hydraulic wing locks and best in class transport clearance for easy and safe road transport

Features & options²

True Speed high speed meter

Blue Drive electric drive and Blue Vantage display

Cast row unit

True Depth hydraulic down force

Active³ hydraulic weight transfer

Bulk fill seed hopper

True Rate vacuum seed meter

Up to 4 planter mounted cameras

High transport clearance

Liquid or dry fertilizer

Articulating clevis hitch



¹Minimum tractor power requirement dependent upon planter configurations and chosen options.

²Not all features are available with all configurations. Visit www.Kinze-Europe.com/planters or your local dealer for details.

³Active hydraulic weight transfer only with bulk fill scales and Blue Drive.



Onboard Liquid or Dry Fertilizer

Efficiently apply liquid or dry fertilizer without pulling a cart or performing a separate operation. The 4805 can be outfitted with 2 280 L or 3 800 L¹ of liquid fertilizer, or with 3 020 L, 5 150L, or 6 130 L² of dry fertilizer to match your farming practices. Application is with durable notched single disc openers for both conventional or no-till planting.

¹ Capacity dependent upon configuration

² Dry fertilizer system is unique by it's fertilizing dosing accuracy



Effortless Fold and Unfold



Feature/Option	4805
Planter Frame/Toolbar	Front Fold
Sections	3
Number of rows per Wing	9
Flexibility	Center Flex 15° up / 15° down
Row markers	●
Hydraulic weight transfer (active hydraulic weight transfer w/bulk fill scale and Blue Drive)	●
Articulating clevis hitch	●
PTO Hydraulic Package	●
Seed Handling	
Row Unit Seed Hoppers	66 L or 105 L
Bulk Fill Seed Hoppers	4 230 L
Bulk Fill Scale Package	●
Transmission/Drive System	
Blue Drive Electric Drive	●
Displays & Control	
Blue Vantage Display (standard with Blue Drive)	●
Single Row Section Control (standard with Blue Drive)	●
Ag Leader 7500 GPS Receiver	●
Metering	
True Speed High Speed Meter (bulk fill only)	●
True Rate Vacuum Meter	●
Row Units	
Rubber V Closing Wheels	●
Cast Iron Closing Wheels	●
Spiked Closing Wheels	●
Spoked Gauge wheels	●
True Depth Hydraulic Down Force	●
Heavy Duty Down Pressure Springs	●
Pneumatic Down Pressure	●
Row Unit Mounted No Till Coulters	●
Residue Wheels	●
Granular Chemical Attachments	●
Fertilizer	
Liquid Fertilizer Packages	●
Dry Fertilizer Packages	●
Notched Single Disc Opener Pkg	●
Liquid Fertilizer Tube In-Furrow	●
Miscellaneous	
Transport Lights and Signs	●
Auxiliary Work Light Package	●
Safety Chain (Drawbar Hitch)	●
Parking Jack	●
Rear Trailer Hitch	●

3005 SERIES FEATURES & OPTIONS

● = Standard ● = Optional

Feature/Option	3605	3505	3205	3035	3005
Planter Frame/Toolbar					
	Pivot Fold	Pivot Fold	Wing Fold	Wing	Rigid
Sections	3	1	2	3	1
Flexibility	Wing Flex 7° up / 7° down	Rigid	Center Flex 13° up / 12° down	Rigid	Rigid
Split Rows	●	●	–	–	●
Even Row Split Row	●	●	–	–	–
Twin Rows	–	●	–	–	–
Row Markers	●	●	●	●	●
Hydraulic Weight Transfer (active hydraulic weight transfer w/ bulk fill scale and Blue Drive)	●	–	–	–	–
Hitch	Articulating Clevis	Clevis	Clevis	Clevis	Clevis
2-point Adapter	●	●	–	–	–
PTO Hydraulic Pump	●	●	●	●	●
Seed Handling					
Row Unit Seed Hoppers	●	●	●	●	●
Bulk Fill Seed Hoppers	2 820 L	1 760 L	–	–	–
Bulk Fill Scale Package	●	–	–	–	–
Transmission / Drive System					
Ground Contact Drive	●	●	●	●	●
Blue Drive Electric Drive	●	●	–	–	–
Displays and Controls					
Blue Vantage Display (std w/Blue Drive)	●	●	–	–	–
Electric Single Row Control	●	●	–	–	–
KPM III Electronic Seed Monitor	●	●	●	●	●
Ag Leader InCommand 1200	●	–	●	–	–
GPS Autoswath or Manual Control	●	●	●	–	–
Electric Single Row Clutches (2 row shut-off for Ag Leader)	●	●	●	–	–
Metering					
True Speed High Speed Meter	● (bulk fill)	● (bulk fill)	–	–	–
True Rate Vacuum Meter	●	●	●	●	●
Mechanical Finger Pick-up	–	–	●	●	●
Mechanical Brush Meter	–	–	●	●	●
Row Units					
Rubber V or Cast Iron Closing Wheels	●	●	●	●	●
Spiked closing wheels	●	●	●	●	●
Spoked gauge wheels	●	●	●	●	●
True Depth Hydraulic Down Force	●	●	–	–	–
Heavy Duty Down Pressure Springs	●	●	●	●	●
Pneumatic Down Pressure	●	●	–	–	–
Row Unit Mounted No Till Coulters	●	●	●	●	●
Residue wheels	●	●	●	●	●
Granular chemical w/hopper	●	●	●	●	●
Fertilizer					
Liquid Fertilizer Packages	●	●	●	●	●
Dry Fertilizer Packages	●	●	–	●	●
Double Disc Opener Package	●	●	●	●	●
Heavy Duty or Notched Single Disc Opener Pkg	●	●	●	●	●
Liquid Fertilizer Tube In-Furrow	●	●	●	●	●
Liquid Fertilizer Pump Packages	●	●	●	●	●
Miscellaneous					
Transport Lights and Signs	●	●	●	●	●
Auxiliary Work Lights	●	●	–	–	–
Safety Chain and Parking Jack	●	●	●	●	●
Rear Trailer Hitch	●	●	–	–	–

MODEL DIMENSIONS AND WEIGHTS

	4805	3605		3505
	24R 70 CM	16 ROW 70 CM	12 ROW 70 CM	8 ROW 70 CM
Length ¹				
Planting - Row Unit Hoppers	-	7.3 m	6.4 m	6.1 m
Planting - Bulk Fill Hoppers	9.3 - 10 m	7.3 m	6.4 m	6.1 m
Transport - Row Unit Hoppers	-	13.3 m	10.5 m	7.6 m
Transport - Bulk Fill Hoppers	13.5 - 14.5 m	13.3 m	10.5 m	7.6 m
Width ¹				
Planting - Row Unit Hoppers	-	11.7 m	9.0 m	6.1 m
Planting - Bulk Fill Hoppers	17.5 m	11.7 m	9.0 m	6.1 m
Transport - Row Unit Hoppers	-	3.2 m	3.2 m	3.1 m
Transport - Bulk Fill Hoppers	4.8 - 5.5 m	3.2 m	3.2 m	3.1 m
Height ¹				
Planting - Row Unit Hoppers	2.2 m	-	-	2.5 m
Planting - Bulk Fill Hoppers	3 - 3.1 m	2.5 m	2.5 m	2.6 m
Transport - Row Unit Hoppers	3 m	3.5 m	3.5 m	3.4 m
Transport - Bulk Fill Hoppers	3.8 - 3.9 m	3.8 m	3.8 m	3.7 m
Weight (empty) ¹				
Base machine - Row Unit Hoppers	12 950-13 050 kg	7 135-7 350 kg	5 795-5 980 kg	3 100-3 300 kg
Base machine - Bulk Fill Hoppers	14 570-17 270 kg	7 075-7 730 kg	6 615-6 915 kg	3 600-3 800 kg
Hitch - Bulk Fill Hoppers, in transport	5 000-5 500 kg	1 750 kg	1 425 kg	-
Hitch - Row Unit Hoppers, in transport	-	925 kg	1 590 kg	-
Weight (full/planting) ¹				
Hitch - Bulk Fill Hoppers	1 000-3 500 kg	-	-	-

MODEL DIMENSIONS AND WEIGHTS

	3205	3035	3005	
	12 ROW 70 CM	8 ROW 70 CM	8 ROW 70 CM	6 ROW 70 CM
Length ¹				
Planting - Row Unit Hoppers	5.4 m	6.8 m	3.5 m / 4.2 m ²	3.5 m / 4.2 m ²
Transport - Row Unit Hoppers	5.4 m	6.6 m	3.5 m / 4.2 m ²	3.5 m / 4.2 m ²
Width ¹				
Planting - Row Unit Hoppers	9.6 m	5.5 m	6.7 m	4.5 m
Transport - Row Unit Hoppers	4.9 m	3.0 m	6.7 m	4.5 m
Height ¹				
Planting - Row Unit Hoppers	-	2.8 m	-	-
Transport - Row Unit Hoppers	2.8 m	3.2 m	-	-
Weight (empty) ¹				
Base machine - Row Unit Hoppers	3 400-3 660 kg	3 500-3 760 kg	2 210-2 515 ¹ kg	1 750-1 995 ¹ kg
Hitch - Row Unit Hoppers	1 350 kg	-	-	

1. length, width, height and weight are dependent on how machine is equipped (meters, drives, hoppers, insecticide, fertilizer, down force, etc.)
 2. with Double-Frame

EXPERIENCE

KINZE®

Visit the Kinze Europe plant in Lithuania and Experience Kinze for yourself.



Factory tour



Meet with our experts



Ride and Drive

CONTACT YOUR DEALER
TO BOOK TODAY



Visit Experience Kinze and:

- get a guided factory tour
- review Kinze products in depth
- speak with experts and ask your questions
- learn about Kinze history

More on other side



Meet our Experts



Brian McKown
Executive Vice President
& Chief Operating Officer
at Kinze U.S.
Director of Kinze Europe



Andrius Pavilionis
Sales Director



Edvardas Melys
Design Engineering Manager



Egidijus Kontrauskis
Service Manager



Gary Newell
Sr. Global Product Specialist

Experience Kinze allows you to meet with our experts and learn about Kinze products, investigate your individual needs, and find Kinze solutions to use on your farming operations.

Hear from our Customers

“ The reliability, simplicity, and outstanding performance of Kinze equipment have truly exceeded our expectations. ”

VEACESLAV CIORNII
MOLDOVA



“ We chose Kinze because we couldn't find other models on the market that meet all our requirements. ”

ION MOROI
MOLDOVA



CONTACT YOUR DEALER
TO BOOK TODAY





PLANTING, HARVESTING AND TILLAGE SOLUTIONS BY FARMERS FOR FARMERS

From a shop in Ladora, Iowa, to today's sophisticated 160-acre manufacturing and corporate headquarters, Kinze has remained focused on one thing: developing innovative advancements in agricultural equipment by listening to what customers have to say. From Jon Kinzenbaw's first day in the welding shop in 1965, customer intimacy has always, and will continue to be, of primary importance to Kinze. The question is, what's next?



Kinze Manufacturing, Inc. • 2172 M Ave
Williamsburg, Iowa 52361-0806 USA • Kinze.com

Kinze Europe UAB
Guopstu Road 17 • Guopstu Village
LT-21148 Trakai District Lithuania • Kinze-Europe.com



Authorized Dealer: